

# BUKH DIESEL

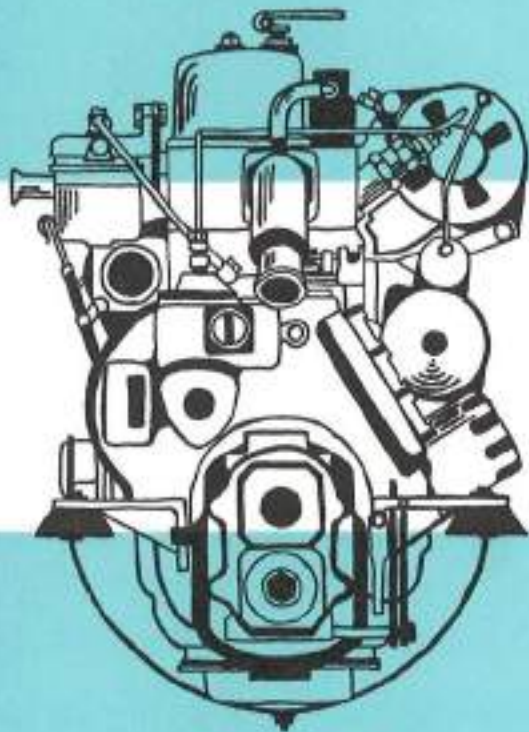

## Owner's Handbook

for

DV 10 M, DV 10 ME and DV 10 SME

DV 20 M, DV 20 ME and DV 20 SME

Registration card for  
original retail  
purchaser

Name: ..... Tel. ....

Address: .....

Town: ..... Country: .....

Model	Engine no.	First used	Model of boat	Boat WL	Disp. in tons	Used for
-------	------------	------------	---------------	---------	---------------	----------

To the owner:

This card is to be completed by the Dealer/Boatbuilder and forwarded to the Distributor not later than 14 days after the engine has been put into operation, to validate the warranty.  
The Distributor will forward this card within 10 days to Motorfabriken BUKH A/S.

DEALER:

Date ..... Signature .....

OWNER:

Date ..... Signature .....

**GUARANTEE**

Motorfabriken BUKH A/S guarantee each new BUKH DV Series Marine Diesel to be capable under normal working conditions of continuously developing the advertised horsepower without overloading its various components. Furthermore, we guarantee each unit sold by us and still owned by the original user to be free from defects in material and workmanship.

This Guarantee shall remain in effect for twelve calendar months from date of purchase. For individual engine parts and accessories which are not manufactured by BUKH, principally electrical and fuel injection equipment, the Guarantee is granted as laid down by the individual subcontractor.

The Guarantee shall not apply in respect of normal wear and tear nor to any unit which has been damaged or has failed due to neglect, accident, abnormal operation, wrong installation, electrolytic corrosion or by repairs or alterations made by un-authorized workshops whether or not using original spares.

The Guarantee shall become effective only when the damaged or faulty part or parts is/are sent free of charge via the authorized Dealer to the National Representative of BUKH accompanied by information as to Engine Serial number, and nature of damage, and the liability shall be limited to repairing or replacing, free of charge, such parts (found by us to be defective) as shall be necessary to remedy any malfunction resulting from defects in materials or workmanship.

The warranty on a new BUKH engine can now be extended to two years provided that before the end of the first year a specified examination is carried out by an authorized BUKH dealer.

The cost of examination will be payable by the engine owner.

The guarantee does not restrict the buyer's rights according to the general rules of current legislation.

The table below is to be filled in by the boat builder/supplier for owner's use in case of future enquiries concerning engine and equipment.

Engine No. ....

Gear No. ....

Key No. ....

Make of propeller .....

Size .....

Make of propeller shaft .....

Length .....

Taper .....

Make of stern tube .....

Length .....

Dimension .....

Make of front stern stuffing box

.....

Type .....

Make of rear stern tube bearing

.....

Type .....

Further equipment not supplied by

BUKH .....

.....

.....

.....

# OWNER'S HANDBOOK FOR BUKH MARINE DIESEL

**DV 10 M, DV 10 ME and DV 10 SME**  
**DV 20 M, DV 20 ME and DV 20 SME**



**AABENRAA MOTORFABRIK**

Heinrich Callesen A/S

Næstmark 30

DK-6200 Aabenraa - Denmark

Telephone: +45 74 62 20 88

Telefax: +45 74 62 74 07

E-mail: [bukh@bukh.dk](mailto:bukh@bukh.dk)

## CONTENTS

	Page		Page
Introduction .....	3	Marine gear .....	19
Pictures for recognition of details .....	4, 5, 6, and 7	Sail drive .....	20
<b>Operating manual</b> .....	8	Propeller equipment .....	21
Preparation for the first start .....	8	Winter storage of the engine .....	22
Running the engine after having been put into service .....	9	Preparation of the engine in Spring .....	23
Before start .....	9	Galvanic corrosion .....	24
Electric start .....	9	Maintenance table .....	25
Hand starting .....	10	Irregular operation – causes and remedies .....	26
After starting .....	11	Technical data for engine and gearbox .....	29
Manoeuvring .....	11	List of extra equipment .....	32
Stopping .....	11		
Running-in .....	11		
Frost precautions .....	12		
<b>Maintenance</b> .....	12		
Belt for charging alternator .....	12		
Air filter .....	13		
Fuel filter .....	13		
Fuel lift pump filter .....	13		
Lubricating oil system .....	14		
Quality of lubricating oil .....	14		
Change of lubricating oil .....	14		
Change of lubricating oil filter .....	14		
Cooling water system .....	15		
Exchange of impeller for cooling water pump .....	15		
Freshwater cooling .....	16		
Eldiagram .....	17		

# Introduction

## **Read this instruction book thoroughly before starting your new BUKH Diesel Engine.**

No BUKH diesel engine is sent from factory without having been thoroughly tested.

The tests have shown that the engine in all aspects is working satisfactorily and is generating its full power.

You will expect the engine to work reliably without giving any problems, and to achieve this you are asked to follow the instructions in this manual.

By so doing, you will get the best from your BUKH engine.

If a problem with the engine should arise, we ask you to apply to one of our dealers, who will always be ready to help you, having skilled personnel, necessary tools etc., and at the same time you will be sure that only original BUKH spare parts are used.

## **Do always use original BUKH spare parts.**

When ordering spare parts at the dealer please state:

Engine type and serial number, description and number of parts.

*We wish you good boating with your new BUKH engine.*

**AABENRAA MOTORFABRIK  
Heinrich Callesen A/S**

BUKH reserve the right to alter specifications without notice.

1. Cooling water pump
2. Oil dipstick
3. Water drain from engine block
4. Fuel lift pump with manual priming
5. Fuel filter
6. Exhaust pipe
7. Regulating lever
8. Bracket for remote control of regulating lever
9. Fuel pump
10. Electro-magnetic stop-coil
11. Lubricating oil pump
13. Bracket for remote control of reversing gear
14. Reverse-reduction gear
15. Coupling flange for propeller shaft
16. Oil dipstick for reverse-reduction gear
17. Reversible engine mountings

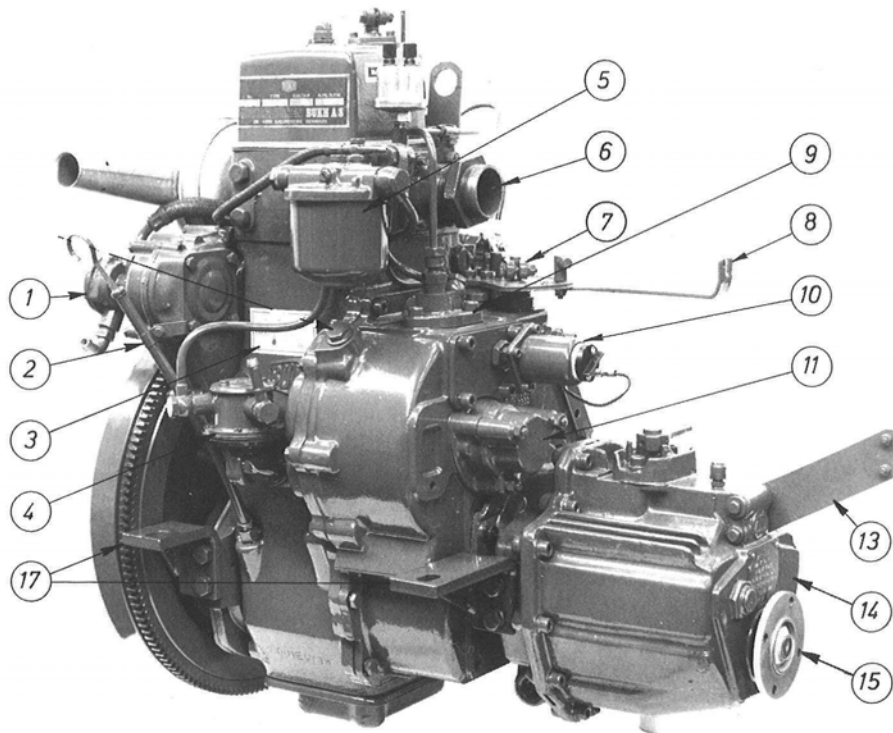

**Fig. 1** DV 10 ME

- 18. Gear lever for reverse-reduction gear
- 19. Lubricating oil filter
- 20. Oil pressure switch
- 21. Oil sump
- 22. Decompression lever
- 23. Oil filling plug
- 24. Cooling water thermostat
- 25. Zink rod
- 26. Nozzle holder
- 27. Air cleaner with silencer
- 28. Raised handstart
- 29. Alternator
- 30. Starter
- 31. Electric multi-plugs

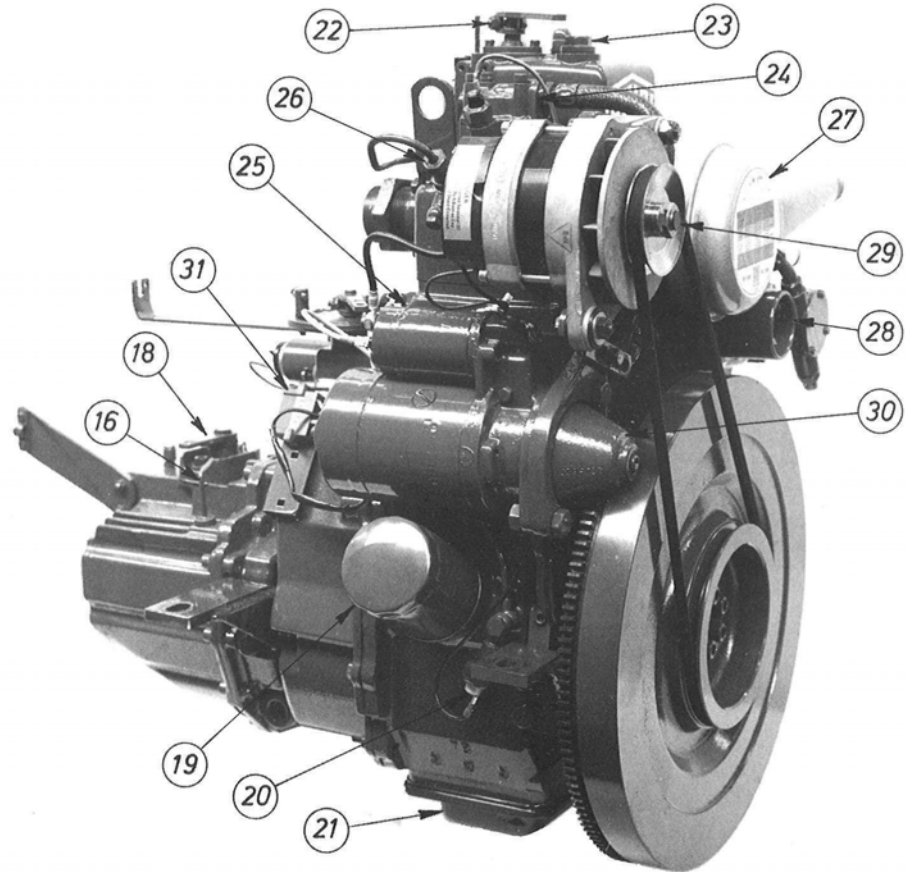
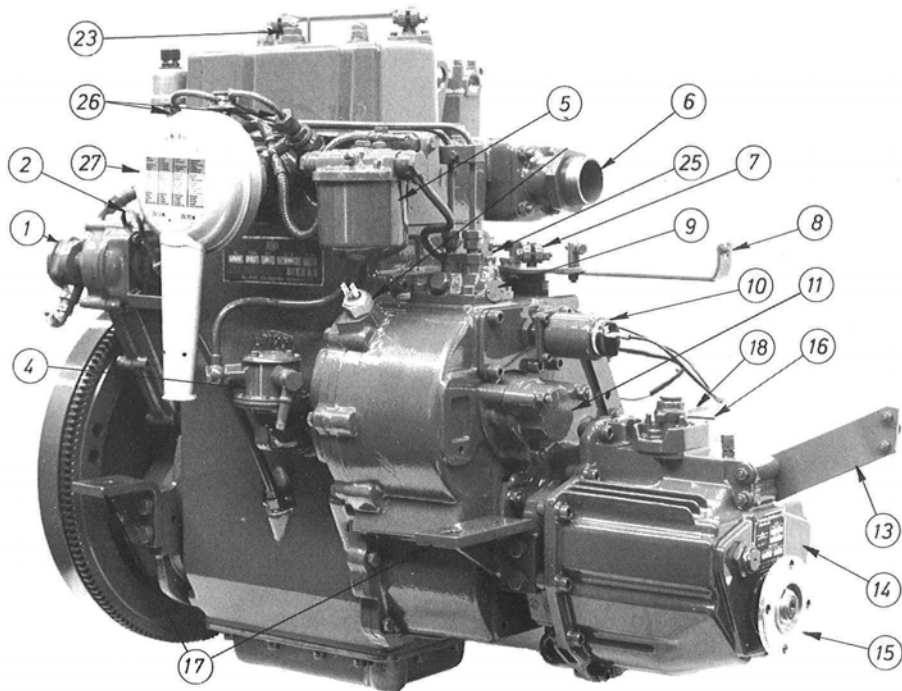

Fig. 2 DV 10 ME

1. Cooling water pump
2. Oil dipstick
3. Water drain from engine block
4. Fuel lift pump with manual priming
5. Fuel filter
6. Water cooled exhaust manifold
7. Regulating lever
8. Bracket for remote control og regulating lever
9. Fuel pump
10. Electro-magnetic stop-coil
11. Lubricating oil pump
13. Bracket for remote control of reversing gear
14. Reverse-reduction gear
15. Coupling flange for propeller shaft
16. Oil dipstick for reverse-reduction gear
17. Reversible engine mountings



**Fig. 3** DV 20 ME



- 18. Gear lever for reverse-reduction gear
- 19. Lubricating oil filter
- 20. Oil pressure switch
- 21. Oil sump
- 22. Decompression lever
- 23. Oil filling plug
- 24. Cooling water thermostat
- 25. Zink rod
- 26. Nozzle holder
- 27. Air cleaner with silencer
- 28. Raised handstart
- 29. Alternator
- 30. Starter
- 31. Electric multi-plugs

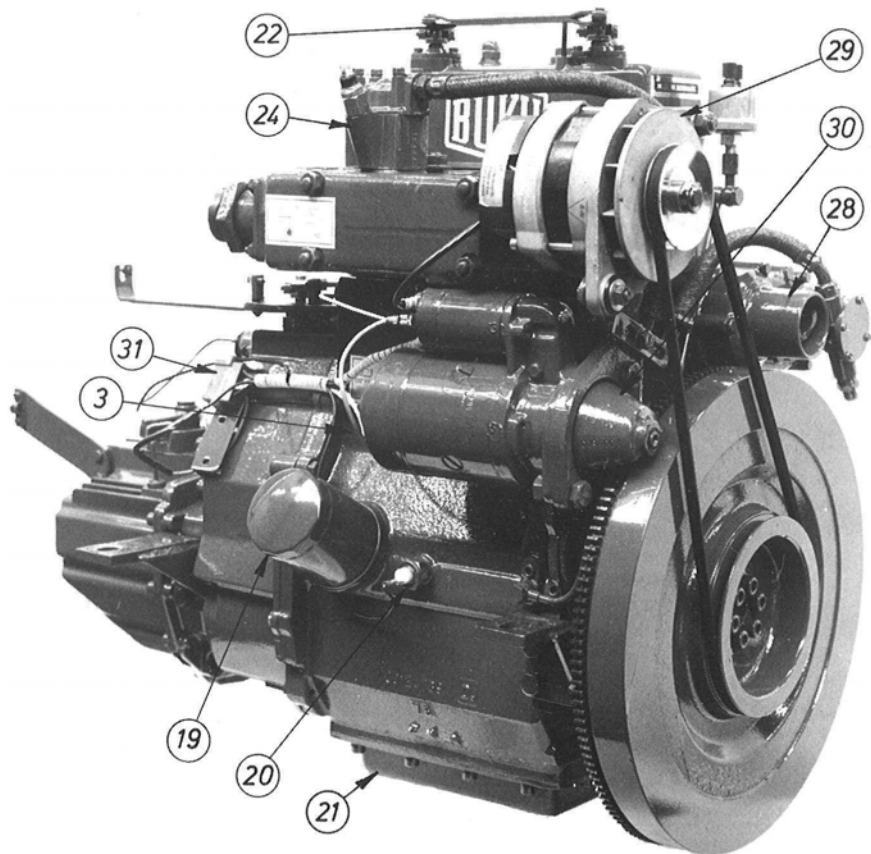

Fig. 4 DV 20 ME

## OPERATING MANUAL

Before the engine is put into use you are recommended to get familiar with the placing of the following components of engine and gear:

Fuel oil filter, lub oil filter and air intake filter, fuel lift pump with handle, zincrod in the crankcase and water-separator in the fuel pipe (if mounted).

Where is lub oil poured in engine and gear and where are the dipsticks placed?

Where is fuel oil filled in the fuel tank and where is the drain plug placed?

Where is the main switch?

### Preparation before first start

1. Pour lubricating oil through filling hole on top of valve cover. (Fig. 5.)  
Check that oil level is between the marks on the dipstick, placed at the port side of the engine. (Fig. 6.)  
Check oil level as mentioned below:
  - a. remove and wipe dipstick
  - b. reinsert dipstick in the pipe
  - c. withdraw dipstick, check oil level.
2. Pour lubricating oil through dipstick hole on the top of reverse- and reduction gear (fig. 2, pos. 16) and check oil level in the following way:
  - a. insert dipstick slowly
  - b. withdraw dipstick and check oil level. The oil level must be between the two marks on the dipstick.
3. Flexible sterntube: Lubricate the stuffing box with sterntube oil (outboard).  
Unscrew the filler plug and oil is poured in until the bearing is full.  
**Important: The stuffing box shall under no circumstances be force-lubricated.**  
These instructions are only valid for propeller equipment supplied by BUKH.  
If other equipment is mounted, we refer to the instructions given for this.
4. We always recommend checking of oil level before start.
5. Fill the fuel tank.

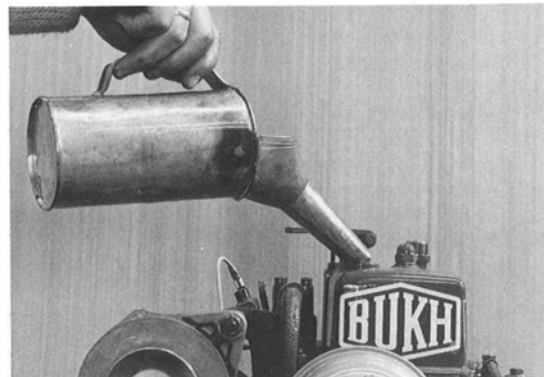

Fig. 5

1. Oil filling plug.

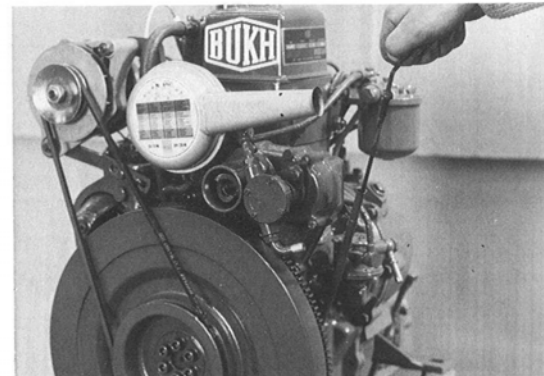

Fig. 6

1. Oil dipstick.

6. Bleed the fuel system as below:
    - a. Pump with the fuel lift pump handle (fig. 8) until fuel is free from air bubbles seen in the transparent hose to the fuel tank.
    - b. Loosen fuel pipe connection on the nozzle holder, if necessary (fig. 3 pos. 26).
    - c. Turn the engine until fuel is free from air bubbles. Retighten the pipe connection.
- Normally it will not be necessary to bleed the fuel system before starting but after changing the fuel filter element or carrying out any work on the fuel system it should be bled in the following way – loosen the bleed screw (fig. 7, pos 2) and operate the hand priming lever on the fuel lift pump (fig. 8, pos. 1) until air free fuel discharges from screw. Tighten bleed screw. Loosen high pressure pipe unions to injectors (fig. 2 and 4, pos. 26) and turn engine until fuel discharges from pipes. Reconnect pipes to injectors. The engine will start in the normal way.

## AFTER THE ENGINE HAS BEEN TAKEN INTO USE

### Before start

1. The oil level of the engine should be checked every 14 days or every 25 hours of running as described in »Preparation before first start«, page 8.  
It is not necessary to refill oil if the level is between the two marks on the dipstick.
2. The oil level of the reduction gear should be checked every 14 days or every 25 hours of running as described in »Preparation before first start«, page 8.
3. The sterntube stuffing box should be lubricated every 14 days or every 25 hours of running.
4. Check the quantity of fuel in the tank.

### Electric start with remote control and instrumental panel

1. Switch on the main switch (fig. 20, pos. 10).
2. Put the marine gear in neutral position by means of the control handle (fig. 10).
3. The engine is started by pushing in the key and turning it to the right.  
The starter should not work for more than 10-15 secs. continuously.

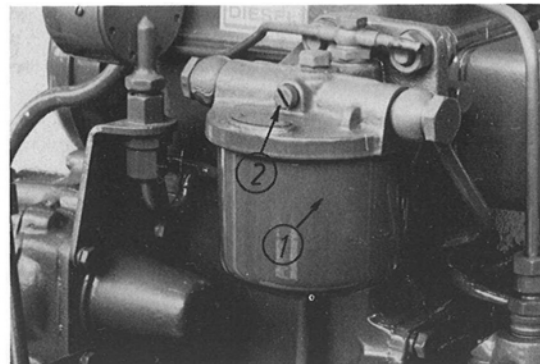

**Fig. 7**

1. Fuel filter
2. Slotted screw for bleeding

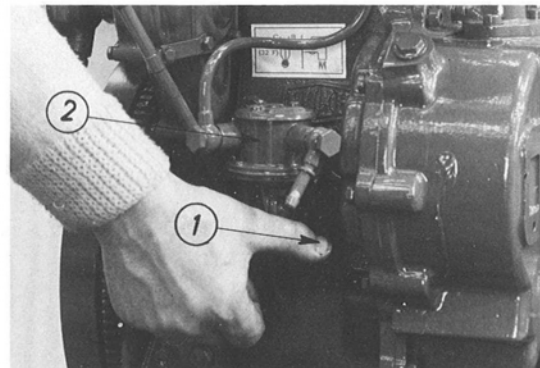

**Fig. 8**

1. Manual priming lever
2. Fuel lift pump

### Hand start

1. Put the gear lever in neutral position (fig. 10).
2. Turn decompression lever on valve cover (fig. 9, item 2) clockwise as far as possible.
3. Engage starting handle and crank engine as quickly as possible. Release decompressor by turning lever anticlockwise while cranking and engine will start.
4. By hand start in cold weather you may achieve an easier start after having cranked the engine with open decompression valve before the start procedure.

### Cold start (with el-start only)

To achieve an easier start in cold weather engines with electric start may be equipped with »Thermostart«-equipment, which is used turning the key to pos. C, where it is hold for 15 to 20 sec. before pushing in start position D. (See fig. 21 – key functions).

**Important: Never speed up a cold engine. Let it get warm first.**

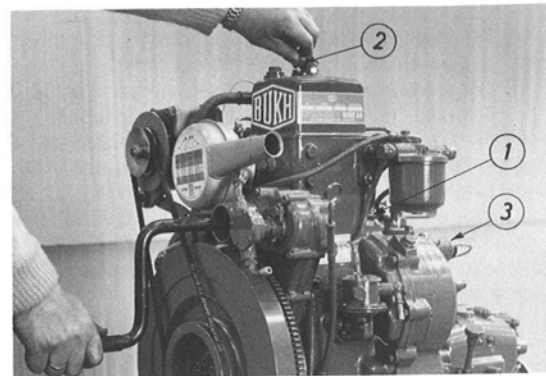

**Fig. 9**

1. Regulating lever
2. Decompression lever
3. Stop solenoid

## Manoeuvring

1. With the control lever in central position the engine is idling, and the marine gear is in neutral (pos. 0). When the lever is moved forward in range 1, the marine gear is engaged to »Ahead« first, and then in range 2 the engine R.P.M. is increased. When the lever is moved from the central position to range 3, the marine gear is engaged to »Astern« first, and then in range 4 the engine R.P.M. is increased.
2. Only engage »Ahead« or »Astern« when the engine is idling.
3. To accelerate engine without engaging gear operate gear release button 5 and move control handle in either direction.
4. Alternatively to the shown side mounted remote control, this can be delivered for top mounting.
5. Increase the load gradually from idling in the course of the first 15-20 minutes shortly after the start of the engine.

## Stopping the engine

1. Reduce the load gradually in the course of 15-20 minutes before stop.
2. Reduce the engine to idling and the gear is put in neutral position.
3. Turn the ignition key left to stop position, pushing it slightly inwards. The key must not be left in this position after the engine has stopped due to the large current consumption of the stop solenoid. (See »Key Switch Function«, page 18.)  
In this position the acoustic alarm will function, when the engine has stopped.

## Running in

To secure long life and maximum power it is recommended to run the engine for the first 25 hours at not more than 80 pct. of the maximum output (about 2700 r.p.m.). You should avoid slow hauling as for instance towage. After the first 25 hours it is recommended to change engine and gear oil and to tighten up the cylinder head and to check or to possibly adjust the tension of the V-belt. Besides, it is recommended to let an authorized service dealer go over engine and installation.

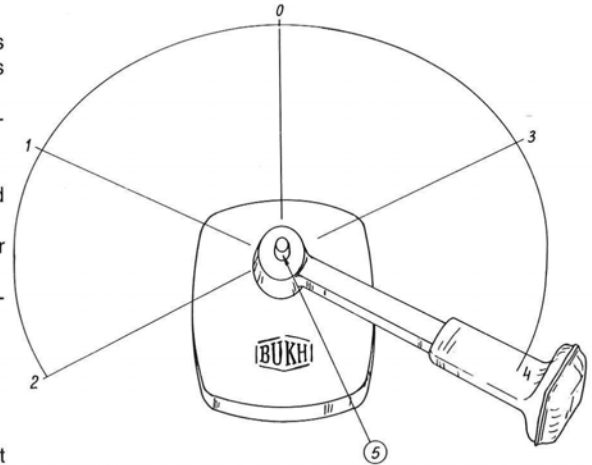

**Fig. 10**

0. Idling in neutral position
1. Idling, gear »Ahead« position
2. Gear in »Ahead« position, increasing R.P.M.
3. Idling, gear in »Astern« position
4. Gear in »Astern« position, increasing R.P.M.
5. Gear release button

## Frost precautions

To avoid damaging the engine, drain the cooling water during frosty periods.

To protect the engine against damage caused by frost, proceed as follows:

1. Turn off the cock on the cooling water inlet skin fitting.
2. Drain the cooling water off the engine:  
DV 10 – Remove the plug. Pos 3 page 4  
DV 20 – Remove the plug on the side of the engine and under the exhaust manifold, respectively.
3. Clean up the drain holes with a nail, a steel wire or the like, so that any remaining water may drain out.
4. Start the engine and let it run for 30 seconds to remove all the water from engine and exhaust manifold. Running for that short time will cause no damage to the impeller of the pump.

Engines fitted with heat exchanger cooling can be protected from frost damage by the addition of 25 per cent glycol to the cooling water.

Heat exchanger cooling water capacities:

DV 10 = 2.75 litres.

DV 20 = 4.80 litres.

Drain the raw water from heat exchanger cooled engines by taking off the seawater pump cover.

## MAINTENANCE

### Belt for alternator

To be adjusted every 150 hours by turning the alternator round the centres of suspension. Tensioning should be so as to allow 15-20 mm ( $\frac{5}{8}$ "- $\frac{3}{4}$ "") deflection of the belt under firm thumb pressure (fig. 11).

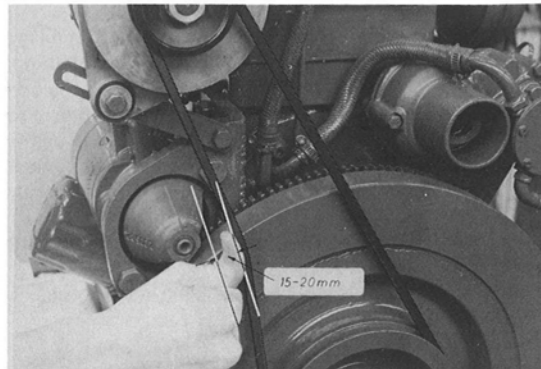

Fig. 11

## Air inlet filter

This is a wire gauze filter to be rinsed in petrol and cleaned by a blast of compressed air after 300 hours' operating.

## Fuel filter

A fuel filter is fitted between the fuel lift pump and the H.P. fuel pump. The filter is a disposable one which cannot be cleaned. It should be changed every 300 operating hours or if water contamination is suspected.

Change the filter as follows:

1. Drain off the fuel from the filter by slackening drain screw A in the bottom of the filter casing B.
2. Remove by hand or by means of a pair of tongs the filter casing and discard it.
3. Clean the sealing surface of the filter holder C if necessary.
4. Fill the new filter casing with clean fuel through the holes at the top of same.
5. Screw on the filter casing and tighten it by hand about half a turn after the gasket fits tightly.
6. After changing the filter, bleed the fuel system as stated under »Preparation for first start«, page 8.

## Fuel lift pump filter

A gauze filter F is placed under the cover E of the fuel lift pump. It should be washed in clean fuel once a year or every 300 operating hours.

Clean the filter by removing the screws D and the cover E. Remove gauze filter F and clean it.

After cleaning, bleed the fuel system as described under »Preparation for the first start« page 9, if necessary.

**IMPORTANT: Adjustment and repair of the fuel system must be made by authorized dealers ONLY.**

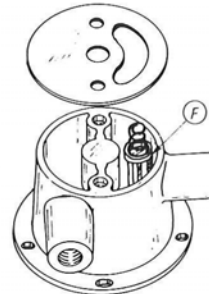
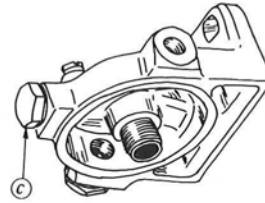

## **Lubricating Oil System**

The engine is pressure lubricated and the oil system has a built-in relief valve for controlling of the oil pressure.

The oil level is checked as mentioned on page 8.

## **Change of Oil**

Lubricating oil should be changed for the first time after 25 hours of running, later for every 150 hours or at least once a year. It is recommended to change the oil with warm engine, and the procedure is as follows:

1. Remove the dipstick (fig. 6).
2. Insert the sump pump suction hose into the hole and pump up the oil.
3. When the sump is empty reinsert dipstick and pour fresh oil as mentioned on page 8.
4. If possible, drain the oil through the plug hole in the bottom of the sump.

## **Recommended Lubricating Oil**

Modern diesel engines demand heavy-duty oils with additives securing best operation conditions and longest life time of the engine under various conditions.

Therefore use a first class HD-oil from a recognized oil company. The oil can must be marked »Service CC«.

Oil specifications as mentioned in »Technical Dates«.

When operating under difficult conditions, i.e. frequent cold starting, short operation periods, very varying loads, use quality »Service CD«, and also use quality »Service CD« in case the sulphur content of fuel is higher than 1 %.

## **Change of Lubricating Oil Filter**

Lubricating oil filter cannot be cleaned, but should be changed every 150 hours or once a year. To change the filter proceed as follows (fig. 14):

1. Unscrew filter and discard it.
2. Mount new filter at once under clean conditions.
3. Screw on filter until gasket seats, tighten a further half turn.
4. Fill with oil until normal level is reached.
5. Start the engine and check that the filter is tight.



## Cooling System

Normally the engine is supplied with salt water cooling-system, and with a thermostat securing a constant engine temperature at varying load.

About cooling water temperature: See »Technical Dates«.

In order to avoid corrosion of the cooling jackets a zinc-rod has been screwed in on the right side of the rear of the crankcase (see pos. 25, fig. 2 and 3).

**The hexagon plug should be removed 2-3 times a year for examination.**

If the zinc-rod is corroded more than 50 % it should be changed.

Water circulation is effected by means of a rotary vane pump with neopren impeller (fig. 15).

## Change of Impeller

Due to the varying temperatures and the one-sided deformation of the impeller during the long winter storage, the rubber impeller should be replaced at the annual launching. Alternatively the impeller can be taken out and kept separately during this period.

If water is coming out at the drain hole at the underside of the flange of the pump against the engine, it is necessary to replace the gasket in the pump as soon as possible.

## Replacement of Impeller

1. Loosen the admission and outlet pipes after having drained off the water from the engine.
2. Remove the pump by dismantling the two screws in the flange of the pump.
3. Remove the front cover of the pump.
4. Press carefully from behind the pump shaft forward so that the impeller is pressed out of the pump housing.
5. Change the impeller by knocking out the through-going thread split.
6. Refitment is made in reverse order. Remove the rear seal ring out of consideration for fitting the small O-ring on the shaft and refit it before the pump is refitted on the engine.

In case of defects on the thermostat, the thermostat will close for the cooling water passage and the engine will thus be too hot. If the thermostat is removed, the by-pass must be shut off.

Too high cooling water temperature will cause the blue lamp in the control panel to light up and the acoustic alarm to function.

Replace the thermostat insert by loosening the four nuts in the top cover of the thermostat housing, then remove the mentioned top cover.

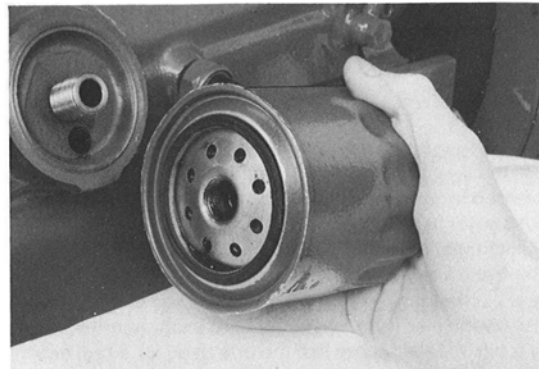

Fig. 14

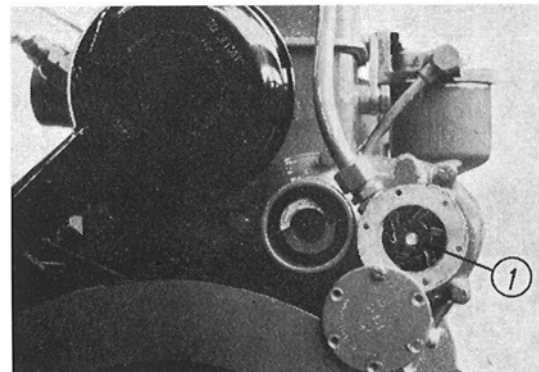

Fig. 15

1. Rubber impeller of cooling water pump.

## Freshwater Cooling

**Fig. 16**

1. Thermostat housing
2. Cooling water shunt
3. Cooling water outlet

When using freshwater cooling it will be possible to reach a higher operating temperature of 70-95°C which will prolong the life of the engine. This cooling system is recommended for engines operating for more than 500 hours a year. A pump circulates the freshwater in a closed system.

This circulation pump is fitted on the front end of the engine.

The freshwater circulates through the cooling jackets of the engine and through the heat exchanger fitted on the water-cooled exhaust manifold.

The freshwater is cooled in the heat exchanger by seawater which is pumped through by a big impeller pump like the one used for direct seawater-cooling.

The seawater leaves the heat exchanger via the exhaust system as in case of seawater cooling.

Too high cooling temperature will cause the blue lamp in the control panel to light up and the acoustic alarm to function.

See »Frost Precautions« page 12 and »Winter Storage of the Engine« page 22.

It is recommended to use a 30 per cent anti-freezing solution on the freshwater side all the year as protection against corrosion.

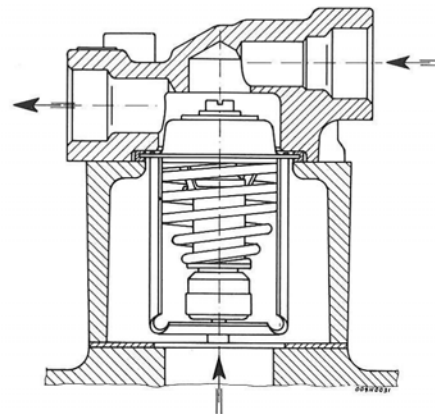
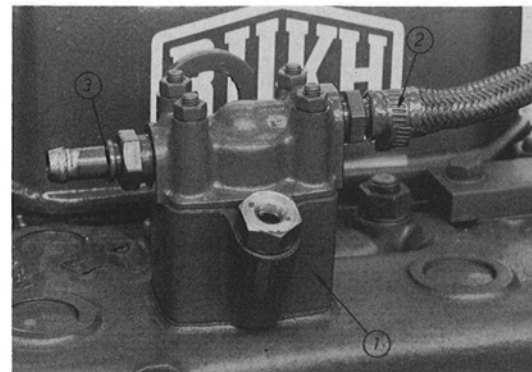

**Fig. 17**

Cross section of thermostat housing



### Explanations to fig. 20:

1. Key switch for start, thermostart and stop
2. Acoustic alarm
3. Warning lamp for oil pressure
4. Warning lamp for electrical charge
5. Warning lamp for water temperature
6. Switch for oil pressure
7. Charging alternator
8. Starter
9. Stop solenoid
10. Main switch \*)
11. Battery (88 AH) \*)
12. Thermostart \*)
13. Water temperature gauge \*)
14. Water temperature transmitter \*)
15. Tachometer \*)
16. Tachometer transmitter \*)
17. Oil pressure gauge \*)
18. Oil pressure transmitter \*)
19. Fuses for start/temperature gauge \*)
20. Fuses for start/thermostart \*)

\*) Additional equipment

### Control Panel

1. Key switch
2. Warning lamp for charging current (AMP, red)
3. Warning lamp for oil pressure (OIL, orange)
4. Warning lamp for cooling-water temperature (TEMP, blue)
5. Acoustic alarm for oil pressure and cooling-water temperature
6. Blank (can be replaced by fuel gauge or hour-meter)

### Instrument Panel

7. Tachometer
8. Cooling-water temperature gauge
9. Oil pressure gauge

### Key Switch Functions

Pos.

- a. Switched off (pos. before insertion and removal of key)
- b. Warning and instrument lamps are alight
- c. Thermostart
- d. Start
- e. Engine stop

### NOTE:

In order to reach positions »d« and »e« the key body must be depressed by means of the key.

The switch should not be left in pos. »e«, because of the heavy consumption of current by the stop solenoid. The alarm functions are tested in pos. »e«.

The starter must not be operated for more than 10 sec. If further operation is necessary, a pause of at least half a minute must be made before starting attempt is repeated.

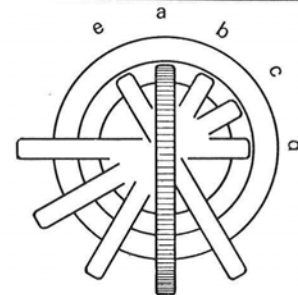
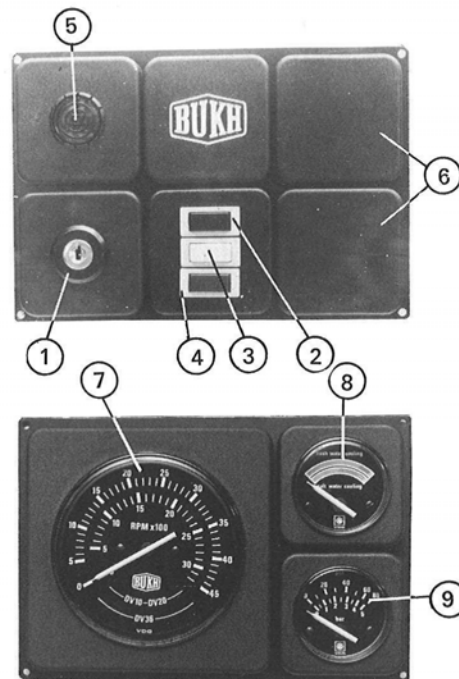

Fig. 21

## Electrical System

The engine is equipped with a 12 volt electrical system consisting of a starter motor and an alternator, the max. charging current of which is 35 Amp.

Electrical wiring diagram for the engine with control and instrument panels is shown on pages 17 and 18.

The level of the electrolyte in the battery should be checked every 14 days or every 25 operating hours. The level should be 5-6 mm above the plates, if this is not the case top up as required.

The battery must never be isolated from the alternator, when the engine is running.

## Marine Gear

The DV 10 and 20 are equipped with a reverse-reduction gear. The reduction is 2,5:1 for AHEAD and 2,36:1 for REVERSE.

The marine gear will need no other attendance than regular change of oil. This to be carried out after 25 hours of operation, and then every 150 hours or once a year.

See oil quality » Technical data« page 29.

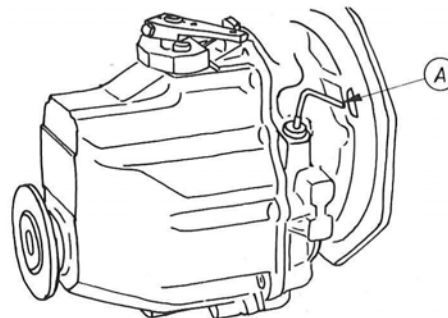

A. Dipstick

## Sail drive

As an alternative to the marine gear, the engine can be equipped with a sail drive. The sail drive has the same function as the reverse-reduction gear.

The reduction is 2.25:1 for AHEAD and for REVERSE.

The sail drive will need no other attention than regular change of oil. Change of oil should be carried out after the first 25 hours of operation, then every 150 hours or once a year.

Carry out the oil change when the boat is on land by loosening the screw »D« in the bottom of the drive, enabling the oil to run out.

Refill with fresh oil to the quantity of 3.3 ltr. through the filter hole »B« at the top of the drive corresponding to the upper mark on the dipstick »A«.

Use the same quality of oil as indicated under »Technical Data« on page 29 for the marine gear.

A replaceable zinc anode »C« is fitted on the sail drive. Check this anode once a year, replace it in case of considerable corrosion.

The sail drive is equipped with a double diaphragm »F« preventing penetration of sea water. In the double diaphragm a sensing element is fitted which releases an acoustic alarm if water penetrates between the two diaphragms. It is important for the sake of safety that this alarm is always serviceable. It should be checked twice a year by short-circuiting the connections 1 and 2 on the plastic box next to the multiple plugs.

When short-circuiting here by means of a piece of wire or a screw-driver, the buzzer should give alarm.

The aluminium housing of the sail drive has been specially treated on the outside. Damage to surface treatment should be treated as soon as possible with special BUKH paint. The sail drive should be coated with the same paint as the rest of bottom of the boat. This paint must not contain copper.

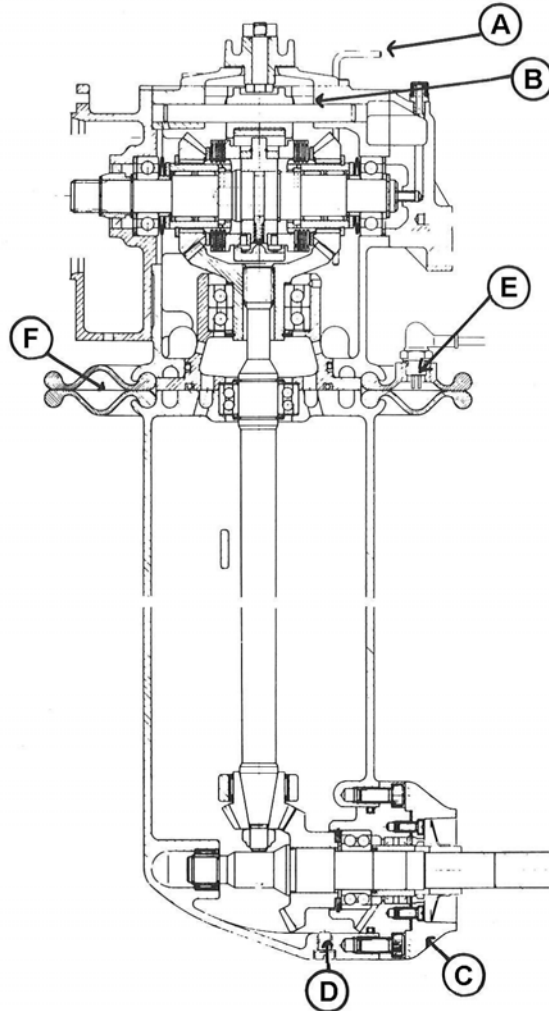

## Propeller equipment (As supplied by BUKH – for other types consult individual manufacturer's instructions)

Flexible stern tube: Every three years replace the three seal rings in the stuffing box »A« and the rubber hose »B« connecting stuffing box and intermediate tube »C«. Fill the flexible stuffing box »A« with Out-board gear oil through the filler hole in this or via the automatic stern tube lubrication »D« supplied as extra equipment to the stern tube arrangement. Normally the consumption of Out-board gear oil is not considerable, and therefore, a sudden increase indicates defective seal rings.

The container »D« should be mounted about 0.25 m above the water line.

### Example of stern tube arrangement

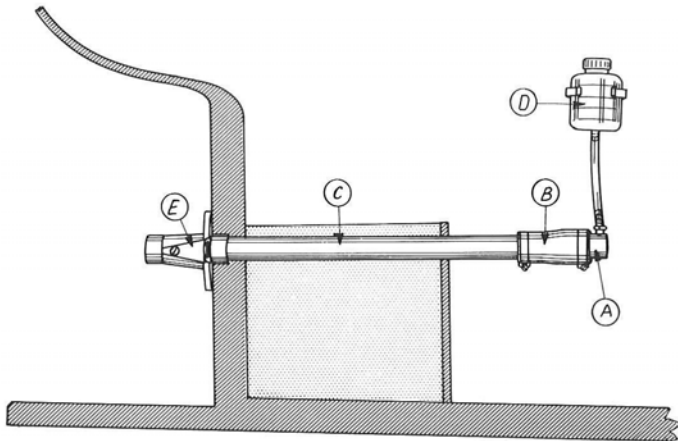

- A. Stuffing box with seal rings.
- B. Flexible tube between stuffing box and stern tube.
- C. Stern tube.
- D. Filler tank for automatic stern tube lubrication.
- E. Rear stern tube bearing (here an example of water lubricated rubber stern bearing with flange).

## **WINTER STORAGE OF THE ENGINE**

### **Carry out the following whilst the boat is still in the water:**

- 1.1. Run the engine until normal working temperature is reached.
- 1.2. Drain off engine and gear oil with the oil bilge pump.
- 1.3. Fill the engine and gearbox with preservative lubricating oil of a recognized make up to the upper mark on the dipstick.
- 1.4. Fill the fuel tank with fuel preservative oil in the rate of mixture prescribed by the oil manufacturer.
- 1.5. Start the engine and let it run for about 10 minutes to be sure that the fuel mixed with preservative oil has been flushed through the fuel system of the engine.
- 1.6. Fill the fuel tank completely with fuel. Pay no special attention to the preservative oil previously added to the fuel as this is consumed normally and properly when service is resumed in spring.

### **On land the following procedure has to be carried out:**

- 2.1. Remove the engine cooling water drain plugs, drain off the sea water from the engine and refit plugs.
- 2.2. For **direct sea water cooled engines**: Remove the suction hose from the cooling water pump at the bottom cock and put the hose into a bucket with freshwater containing preservative oil in the rate of mixture prescribed by the oil manufacturer.
- 2.3. The outlet hose for the cooling water which goes into the exhaust elbow may be removed and returned to the bucket via a length of hose so that the freshwater is able to circulate. Start the engine and the freshwater containing preservative oil will be flushed through the engine.
- 2.4. Stop the engine after 5-10 minutes and drain off the water. Ensure that after removing the drain plug (DV 10: 1 plug placed in the block, see fig 1, pos. 3. DV 20: 1 plug placed in the block, see fig 3, pos. 3, and 1 plug in the exhaust manifold) all the water is drained off. This is done by cleaning the drain holes with a nail, a steel wire or the like, so that any remaining water may drain out. Remove the impeller from the cooling water pump, which will allow water in pump and pipes to be drained off. Keep the impeller separately in a dry place during winter.



- 2.4. A. For **freshwater-cooled engines**: Drain the freshwater from the engine by removing the plugs as indicated for seawater cooled engines. It is not necessary to flush this system with freshwater containing preservative oil. If the engine is to be used in period of frost, it must be protected against frost burst with a mixture of anti-freeze solution in the freshwater system – irrespective of the protection to the freshwater system against the risk of frost – by removing the cover of the impeller pump and turning the engine manually or with the starter motor.
- 2.5. Remove the battery and store it separately during winter in a dry and frost-free place. Fill up and charge the battery before storing.
- 2.6. Remove the air filter and turn the engine manually until each inlet valve opens alternately, during which about ½ cup of preservative oil is injected into each piston head. Turn the engine backwards and forwards manually in order to spread the preservative oil.
- 2.7. Insert a clean, oil moistened rag (not cotton waste) into the inlet manifold.
- 2.8. Insert another clean, oil moistened rag into the exhaust elbow aperture.
- 2.9. Treat electrical connections with grease free from acid. Fill the multiple plugs with grease from the wire side.

The engine is now preserved for winter storage and can be further protected by a covering of polythen sheeting, under which a bucket of silicagel should be placed.

### **Preparation of engine before launching**

- 3.1. Remove the oil moistened rags from the inlet manifold and the aperture of the exhaust elbow.
- 3.2. Fit the cooling water pump impeller.
- 3.3. Fit cooling water drain plugs.
- 3.4. Drain the preservative lubricating oil from both engine and gearbox and fill up with fresh oil to the upper mark on the dipstick.
- 3.5. Change the lubricating oil filter.
- 3.6. Make sure – before starting up – that the oil on the piston heads is drained off. This is checked by turning the engine manually without operating the decompression lever.
- 3.7. Examine the stern tube stuffing box and fill up with stern tube oil.
- 3.8. Fit the battery after re-charging.
- 3.9. Lubricate all moveable parts with oil.
- 3.10. Check the anode.
- 3.11. Check that there is electric contact at the sterntube at the internal connection to the gearbox (fig. 19).

## GALVANIC CORROSION

To avoid corrosion of the propeller due to galvanic action it is advisable to fit a sacrificial zinc anode on the outside of the hull. To obtain a high degree of protection, electrical contact between sacrificial zinc (anode) and propeller (cathode) has to be established. This is obtained by fitting the sacrificial zinc and connecting electrically, as shown on the sketch below.

For the DV 10 and DV 20 a sacrificial zinc of BERA 2B type is recommended.

The sacrificial zinc must not be painted or be otherwise insulated, as this will prevent the zinc from corroding.

The sacrificial zinc must be checked every time the boat is ashore, or at least twice a year.

If the corrosion turns out to be very heavy, bigger anodes, e.g. 2pcs. BERA 2B or 1pc. BERA 1, should be fitted. If there is no corrosion, check the electrical connections. A good way of fitting the sacrificial zinc is to fold down one of its flaps and to clamp it to the stern bearing by means of a rustproof clip as shown on the sketch.

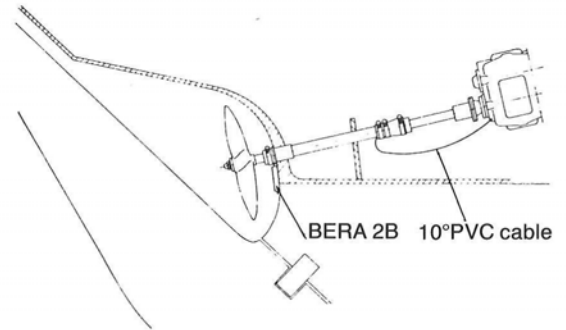

Fig. 19

## Maintenance table

	Every 25 hours	Every 150 hours	Every 300 hours	Every 600 hours	At each annual launching
<b>Check:</b>					
Engine oil level	×				×
Marine gear oil level	×				×
Liquid level of battery	×				×
Stern tube lubrication	×				×
Nozzles (or as required)				×	
Electric starter				×	
Zinc anodes (or as required)	×				×
<b>Change:</b>					
Lubricating oil			×		×
Gear oil			×		×
Lubricating oil filter			×		×
Fuel filter			×		×
Cooling-water pump impeller					×
<b>Clean:</b>					
Fuel lift pump filter		×			×
Air filter			×		
Vacuum valve			×		
Oil sump and oil suction filter				×	
<b>Adjust:</b> (If necessary)					
Belt		×			

## IRREGULAR OPERATION – CAUSES AND REMEDIES

### 1. Engine does not start

Symptom:	Cause:	Remedy:
Insufficient or very little compression	Inlet and/or exhaust valves leaking	Grind or replace the valves, mill the seats
–	Inlet and exhaust valves sticking	Grease valve stems with $\frac{2}{3}$ gas oil and $\frac{1}{3}$ lub. oil, if necessary clean the valves
–	Insufficient rocker arm clearance	Adjust to 0.25 mm inlet and 0.3 mm exhaust when engine is cold. (Turn left)
–	Piston rings stuck in grooves or are worn	Replace piston rings
–	Valve springs broken or weak	Replace springs
Insufficient or no pressure from fuel pump	Air in fuel system or nozzle sticking	Bleed or renew nozzle
Thermo-start out of order	No fuel (valve leaking)	Fill up (renew Thermo-start)
–	Electric supply out of order	Check and/or replace switch and connections. Check fuse
Engine does not reach normal rev.	Unloaded battery or defective	Battery to be charged or renewed
Starter motor turns the engine too slowly	Loose or corroded connections	Tighten or clean connections

### 2. The engine starts, but stops soon after

The engine starts but stops soon after	Empty fuel tank	Refill and bleed
–	Air in fuel system	Bleed
–	Nozzle sticking	Replace nozzle
	Fuel filter choked	Replace filter element Clean the tank

### 3. The engines does not reach maximum output

**Symptom:**

**Cause:**

**Remedy:**

Difficult to start	None or insufficient compression	See »Engine does not start«
The engine r.p.m. is reduced considerably when loaded	Fuel supply choked up Air/water in the fuel system	Check fuel system thoroughly
–	Governor incorrectly adjusted or something in the system works sluggishly	Adjust the governor Check governor system and correct the error
Hot engine (smell of heat)	Insufficient cooling water supply	Stop engine Check cooling water pump
–	Damaged cylinder liner or bearings	Check bearings, piston and cylinder If necessary replace them

### 4. The engine knocks

The engine runs unevenly	Air/water in fuel system	Bleed, see under »Engine does not start«
--------------------------	--------------------------	--

### 5. The engine smokes

Black smoke	Air inlet filter choked	Clean filter
–	Insufficient compression	See under »Engine does not start«
Blue smoke	The lube oil passes piston and oil rings and penetrates into combustion chamber, or vacuum valve defective	Replace oil rings and possibly the piston rings Clean vacuum valve
Gray smoke	Thermostart valve is leaking	Replace

### 6. Excessive consumption of lubricating oil

**Symptom:**

**Cause:**

**Remedy:**

Blue smoke	Oil- and piston rings are worn	Replace oil rings and piston rings too, if required
–	Piston and cylinder liner highly worn	Replace
–	Defective vacuum valve	Replace
Lubricating oil leaks out of crankshaft bearings	Worn oil seal rings	Replace

### 7. The engine gets too warm or too cold

Cooling water temperature too high (Smell of heat)	Unsufficient cooling water supply caused by: defective water pump, choked strainer or a defective thermostat	Investigate pump rotor for broken wings or lost driver screw. Clean strainer Clean or replace thermostat
Cooling water temperature too low	Defective thermostat	Clean or replace thermostat

### 8. Insufficient or no lub. oil pressure

Oil warning lamp lights up Oil pressure gauge indicates abnormally low oil pressure	Insufficient lube oil in the engine	Check and refill
–	Leakage in lube oil system	Tighten and refill
–	Relief valve sticking or spring too weak	Clean bore and valve, stretch or replace the spring



## Fuel System

Combustion system .....	
Injection pressure .....	
Injection timing .....	
Fuel lift pump .....	
Pressure of fuel lift pump .....	
Fuel filter (throw away filter insert) .....	
Fuel quality gas oil .....	

## Lubricating System

### Engine

Type of lubricating oil pump .....	
Lubricating oil pressure (warm engine) .....	
Lubricating oil pressure, minimum .....	
Lubricating oil quality .....	
Lubricating oil viscosity .....	temp.

Lubricating oil capacity, incl. filter .....	
Lubricating oil (throw away filter) .....	

### ZF-marinegear

Lubricating oil quality .....	
Lubricating oil viscosity .....	
Lubricating oil temperature .....	
Lubricating oil capacity .....	

### Stern tube (flexible)

Lubricant .....	
-----------------	--

### Sail drive

Lubricating oil capacity .....	
Lubricating oil quality .....	

## DV 10

two stage combustion  
150 kp/sq.cm (2135 p.s.i.)  
automatic variable  
S.E.V. Marchal  
0.325-0.562 kp/sq.cm (4.62-7.99 p.s.i.)  
Bosch 0450015014  
BS 2869, Class A

## DV 20

Eaton  
2-4 kp/sq.cm (28.4-56.9 p.s.i.)  
1 kp/sq.cm (14.22 p.s.i.)  
service CC or CD

below +5°C (41°F): SAE 10  
or SAE 5 W-20

between +5°C (41°F) and 25°C (77°F): SAE 20  
above +25°C (77°F): SAE 30  
1.75 ltr. (0.39 I.G.) 2.75 ltr. (0.6 I.G.)

OK-SF 4

API, CC or CD, MILL-L-4615  
SAE 30  
max. 120°C (248°F)  
1.1 ltr. (0.25 Imp. Gall.)

outboard gear oil

3.3 ltr.  
API, CC or CD, MILL-L-4615



## Cooling System

Cooling water temperature .....  
Type of pump .....  
Pump capacity .....  
Pump back pressure .....  
Pump suction head (manometric) .....

DV 10

50-75°C (122-167°F)  
JOHNSON 10-35118-1  
max. 11 ltr./min.  
max. 6 m (19.69') W.C.  
max. 3 m (9.85') W.C.

DV 20

## Electrical System

Battery voltage .....  
Battery capacity .....  
Starter type .....  
Starting output .....  
Alternator .....  
Charging output .....  
Solenoid .....

12 volt  
max. 88 Ah  
PARIS-RHONE D9E 51.101.501  
1.3 kW  
PARIS-RHONE-A 13 N1M-100605  
700 Watt  
BOSCH 0.330.101.024

## Torques

Cylinder head bolts .....  
Connecting rod bolts .....  
Nozzle holder in precombustion chamber .....  
Precombustion chamber .....  
Flywheel .....  
Counter weight .....  
Stanchion for rocker arm .....  
Nozzle .....  
ZF-gearbox .....  
Intermediate bearing hub and fixing .....  
Flexible coupling between engine and gear .....

15-17 kpm (108-123 ft.lb) 9.5-10.5 kpm (69-76 ft.lb)  
4.7-5.3 kpm (34-38 ft.lb)  
6-8 kpm (43.5-58 ft.lb)  
24-25 kpm (174-181 ft.lb)  
8-8.5 kpm (58-61.5 ft.lb)  
8-8.5 kpm (58-61.5 ft.lb)  
4-4.5 kpm (29-31.5 ft.lb)  
6-8 kpm (43.5-58 ft.lb)  
2-3 kpm (14.5-22 ft.lb)  
5.2-5.8 kpm (37.5-41.8 ft.lb)  
6-6.5 kpm

## Optional Extra equipment

The complete installation includes a number of items of installation equipment such as propeller and stern tube assembly, exhaust system, water inlet system, flexible mounts etc., details of which appear in the relevant price list.

There are also a number of accessory kits which can be added to the installation at a later date i.e.

<b>Order No.</b>	<b>Description</b>
021D2204	Thermostart DV 10
022D2204	Thermostart DV 20
020D2315	Double charging diode for charging two batteries
020D2114	Hour-meter to be fitted in control panel
020D2113	Tank gauge to be fitted in control panel
020D2316	Fuse box
021D1208	Freshwater cooling with heat exchanger – DV 10
022D1210	Freshwater cooling with heat exchanger – DV 20
020D9102	Water separator for fuel
020D4319	Neoprene silencer
020D8117	Automatic lubrication of stern tube
020D8124	Coupling for propeller shaft
020D2801	V-belt pulley 3 A grooves, 125 Ø mm, to be fitted on the front end of the engine for power take-off of max. 10 HP
020D1601	Zinc Anode for external fitting (0.2 kg)
020D1602	Zinc Anode for external fitting (1.0 kg)
020D2306	Main Switch
021D4211	DV 10
022D4210	DV 20 – Set of spare parts (seawater-cooled engines) consisting of: <ul style="list-style-type: none"><li>– Fuel filter</li><li>– Lubricating oil throw-away filter</li><li>– Fuel pressure pipe(s)</li><li>– Cooling water pump impeller</li><li>– V-belt for charging generator</li><li>– Original BUKH red paint</li></ul>
021D4212	Set of spare parts containing the same parts as order
022D4211	No. 021D4211 and 022D4210 but adapted for freshwater-cooled engines



