

# **YAMAHA**

**Marine**

# **Outboards**

USA, CANADA

**9.9V, 15V**

# **SERVICE MANUAL**



## NOTICE

This manual has been prepared by the Yamaha Motor Company primarily for use by Yamaha dealers and their trained mechanics when performing maintenance procedures and repairs to Yamaha equipment. It has been written to suit the needs of persons who have a basic understanding of the mechanical and electrical concepts and procedures inherent in the work, for without such knowledge attempted repairs or service to the equipment could render it unsafe or unfit for use.

Because the Yamaha Motor Company Ltd. has a policy of continuously improving its products, models may differ in detail from the descriptions and illustrations given in this publication. Use only the latest edition of this manual. Authorized Yamaha dealers are notified periodically of modifications and significant changes in specifications and procedures, and these are incorporated in successive editions of this manual.

A10001 17

**9.9F, 15F  
SERVICE MANUAL**  
©1996 Yamaha Motor Co., Ltd.  
1st Edition, May 1996  
All rights reserved.

No part of this publication may be reproduced or transmitted in any form or by any means including photocopying and recording without the written permission of the copyright holder.

Such written permission must also be obtained before any part of this publication is stored in a retrieval system of any nature.

**F/N LIT-18616-01-65**

---

## HOW TO USE THIS MANUAL

### MANUAL FORMAT

All of the procedures in this manual are organized in a sequential, step-by-step format. The information has been compiled to provide the mechanic with an easy to read, handy reference that contains comprehensive explanations of all disassembly, repair, assembly, and inspection operations.

In this revised format, the condition of a faulty component will precede an arrow symbol and the course of action required will follow the symbol, e.g.,

- Bearings  
Pitting/Damage → Replace.

To assist you to find your way about this manual, the Section Title and Major Heading is given at the head of every page.

On the first page of each Section is an Index of that section's contents.

### MODEL INDICATION

Multiple models are shown in this manual. These indications are noted as follows.

Model name	9.9F	15F
USA and CANADA name	9.9MH, 9.9EH, 9.9ER	15MH, 15EH
Indication	9 9	15

### THE ILLUSTRATIONS

Some illustrations in this manual may differ from the model you have. This is because a procedure described may relate to several models, though only one may be illustrated. (The name of model described will be mentioned in the description).

### REFERENCES

These have been kept to a minimum; however, when you are referred to another section of the manual, you are told the page number to go to.

## HOW TO READ DESCRIPTIONS

1. A disassembly installation job mainly consists of the exploded diagram ①.
2. The numerical figures represented by the number ② indicates the order of the job steps.
3. The symbols represented by the number ③ indicates the contents and notes of the job. For the meanings of the symbols, refer to the next page(s).
4. The REMOVAL AND INSTALLATION CHART ④ is attached to the exploded diagram and explains the job steps, part names, notes for the jobs, etc.
5. The SERVICE POINTS, other than the exploded diagram, explains in detail the items difficult to explain in the exploded diagram or REMOVAL AND INSTALLATION CHART, the Service points requiring the detailed description ⑤, etc.

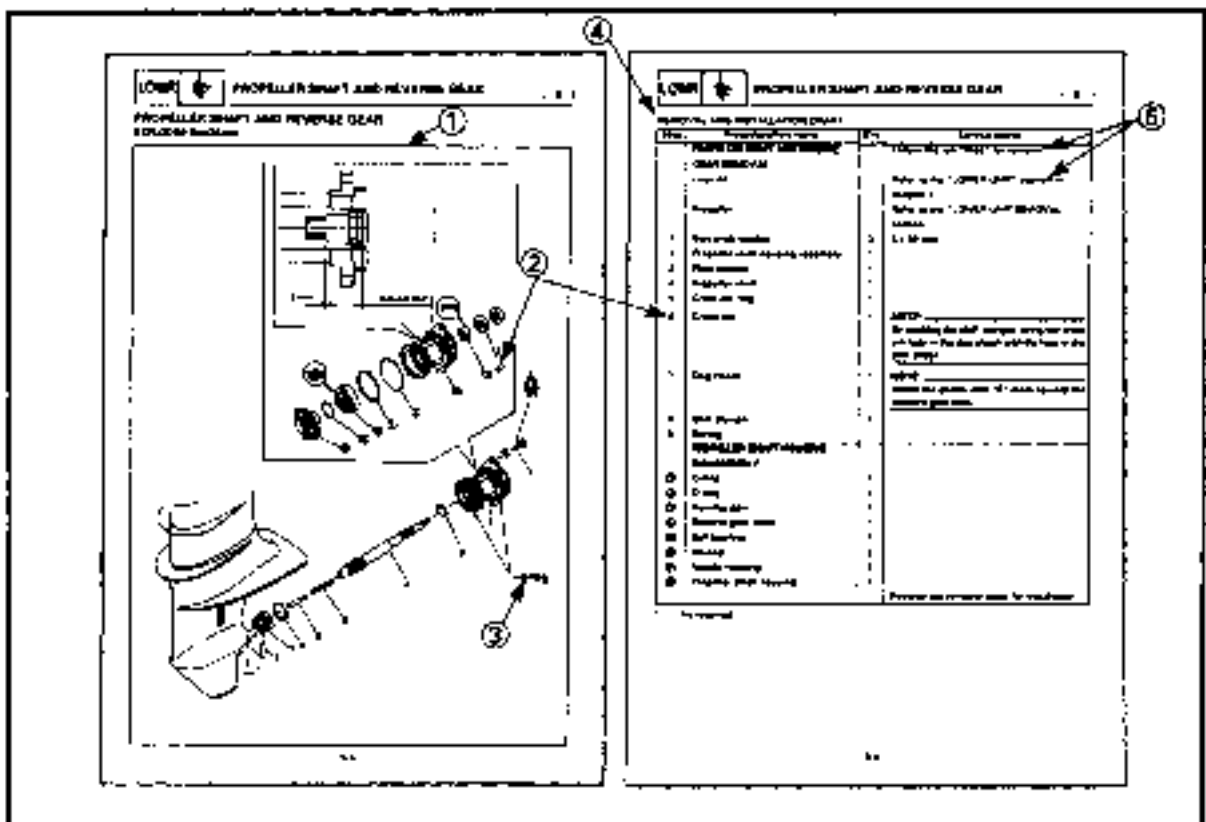

---

## **WARNINGS, CAUTIONS AND NOTES**

Attention is drawn to the various Warnings, Cautions and Notes which distinguish important information in this manual in the following ways

 The Safety Alert Symbol means **ATTENTION! BECOME ALERT! YOUR SAFETY IS INVOLVED!**

---

### **WARNING**

Failure to follow **WARNING** instructions could result in **severe injury or death** to the machine operator, a bystander, or a person inspecting or repairing the outboard motor.

---

### **CAUTION:**

























A **CAUTION** indicates special precautions that must be taken to avoid damage to the outboard motor.

---

### **NOTE:**

A **NOTE** provides key information to make procedures easier or clearer.

---

① GEN INFO 	② SPEC 
③ INSP ADJ 	④ FUEL 
⑤ POWR 	⑥ LOWR 
⑦ BRKT 	⑧ ELEC 
⑨ TRBL ANLS 	⑩ 
⑪ 	⑫ 
⑬ 	⑭ 
⑮ 	⑯ 
⑰ 	⑱ 
⑲ 	⑳ 
㉑ 	㉒ 
㉓ 	㉔ 

## SYMBOLS

Symbols ① to ⑨ are designed as thumb-tabs to indicate the content of a chapter:

- ① General information
- ② Specifications
- ③ Periodic Inspection and Adjustment
- ④ Fuel system
- ⑤ Power unit
- ⑥ Lower unit
- ⑦ Bracket unit
- ⑧ Electrical system
- ⑨ Trouble-analysis

Symbols ⑩ to ㉔ indicate specific data:

- ⑩ Special tool
- ⑪ Specified liquid
- ⑫ Specified engine speed
- ⑬ Specified torque
- ⑭ Specified measurement
- ⑮ Specified electrical value  
(Resistance [Ω], Voltage [V], Electric current [A])

Symbols ⑯ to ㉔ in an exploded diagram indicate grade of lubricant and location of lubrication point:

- ⑯ Apply Yamaha 2-stroke outboard motor oil
- ⑰ Apply water resistant grease  
(Yamaha grease A, Yamaha marine grease)
- ⑱ Apply molybdenum disulfide grease

Symbols ⑲ to ㉔ in an exploded diagram indicate grade of sealing or locking agent, and location of application point:

- ⑲ Apply Gasket Maker<sup>®</sup>
- ⑳ Apply Yamabond #4 (Yamaha bond No. 4)
- ㉑ Apply LOCTITE<sup>®</sup> No. 271 (Red LOCTITE)
- ㉒ Apply LOCTITE<sup>®</sup> No. 242 (Blue LOCTITE)
- ㉓ Apply LOCTITE<sup>®</sup> No. 572
- ㉔ Apply Silicon sealant









## NOTE:

In this manual, the above symbols may not be used in every case.





# INDEX

<b>GENERAL INFORMATION</b>		<b>1</b>
	GEN INFO	
<b>SPECIFICATIONS</b>		<b>2</b>
	SPEC	
<b>PERIODIC INSPECTION AND ADJUSTMENT</b>		<b>3</b>
	INSP ADJ	
<b>FUEL SYSTEM</b>		<b>4</b>
	FUEL	
<b>POWER UNIT</b>		<b>5</b>
	POWR	
<b>LOWER UNIT</b>		<b>6</b>
	LOWR	
<b>BRACKET UNIT</b>		<b>7</b>
	BRKT	
<b>ELECTRICAL SYSTEM</b>		<b>8</b>
	ELEC	
<b>TROUBLE-ANALYSIS</b>		<b>9</b>
	TRBL ANLS	



---

## CHAPTER 1 GENERAL INFORMATION

<b>IDENTIFICATION</b> .....	1-1
SERIAL NUMBER .....	1-1
STARTING SERIAL NUMBER .....	1-1
<b>SAFETY WHILE WORKING</b> .....	1-2
FIRE PREVENTION .....	1-2
VENTILATION .....	1-2
SELF-PROTECTION .....	1-2
OILS, GREASES AND SEALING FLUIDS .....	1-2
GOOD WORKING PRACTICES .....	1-3
DISASSEMBLY AND ASSEMBLY .....	1-4
<b>SPECIAL TOOLS</b> .....	1-5
MEASURING .....	1-5
REMOVAL AND INSTALLATION .....	1-6

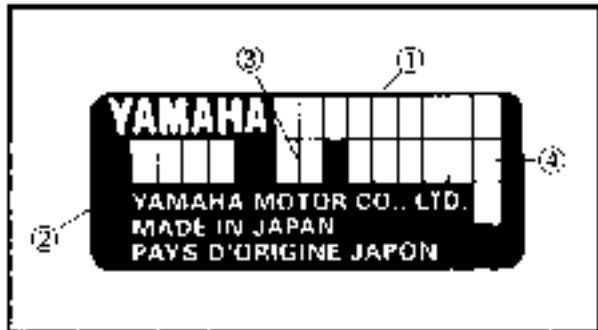
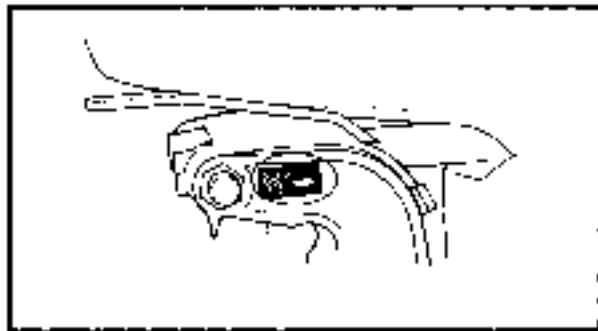

**IDENTIFICATION**

**SERIAL NUMBER**

The serial number of the outboard motor is stamped on the label attached to the port side of the clamp bracket.

**NOTE:**

For USA model:

As an anti-theft measure, a special label on which the outboard motor serial number is stamped is bonded to the port side of the clamp bracket. The label is specially treated so that peeling it off causes cracks across the serial number.

- ① Model name
- ② Approved model No.
- ③ Transom height
- ④ Serial number

**STARTING SERIAL NUMBERS**

The starting serial number blocks are as follows:

Model		Approved model code	Starting serial No.
World-wide	USA, CANADA		
9.9FMH	9.9MH	682C	S: 155582- L: 455181- SUL: 850198-
9.9FEMH	9.9EH		S: 700301- L: 800781- SUL: 900141-
9.9FEMHR	—		S: 630246- L: 680183-
9.9FEMR	9.9ER		L: 690258-
15FMH	15MH	684C	S: 405487- L: 153352- SUL: 830146-
15FEMH	15EH		S: 300231- L: 800511- SUL: 800131-
15FEMHR	—		S: 380261- L: 650243-



## SAFETY WHILE WORKING

The procedures given in this manual are those recommended by Yamaha to be followed by Yamaha dealers and their mechanics.



### FIRE PREVENTION

Gasoline (petrol) is highly flammable. Petroleum vapor is explosive if ignited. Do not smoke while handling gasoline (petrol), and keep it away from heat, sparks, and open flames.

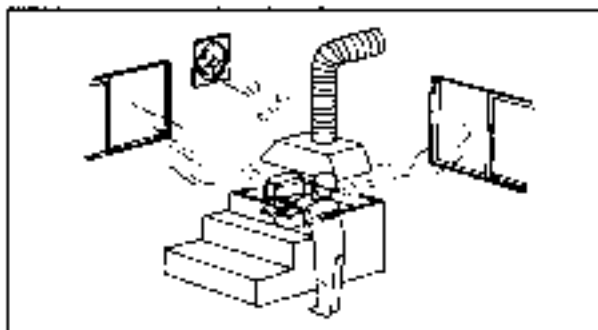

### VENTILATION

Petroleum vapor is heavier than air and if inhaled in large quantities will not support life. Engine exhaust gases are harmful to breathe. When test-running an engine indoors, maintain good ventilation.



### SELF-PROTECTION

Protect your eyes with suitable safety spectacles or safety goggles when using compressed air, when grinding or when doing any operation which may cause particles to fly off. Protect hands and feet by wearing safety gloves or protective shoes if appropriate to the work you are doing.



### OILS, GREASES AND SEALING FLUIDS

Use only genuine Yamaha oils, greases and sealing fluids or those recommended by Yamaha.



Under normal conditions of use, there should be no hazards from the use of the lubricants mentioned in this manual, but safety is **all-important**, and by adopting good **safety practices**, any risk is minimized. A summary of the most important precautions is as follows

1. While working, maintain good standards of personal and industrial hygiene.
2. Clothing which has become contaminated with lubricants should be changed as soon as practicable, and laundered before further use.
3. Avoid skin contact with lubricants; do not, for example, place a soiled wiping-rag in one's pocket
4. Hands, and any other part of the body which have been in contact with lubricants or lubricant-contaminated clothing, should be thoroughly washed with hot water and soap as soon as practicable.
5. To protect the skin, the application of a suitable barrier cream to the hands before working is recommended.
6. A supply of clean lint-free cloths should be available for wiping purposes.

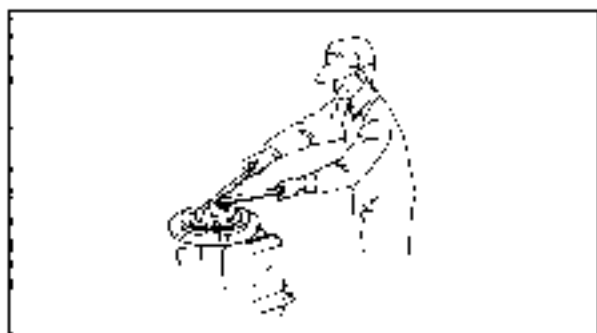

#### GOOD WORKING PRACTICES

##### 1. The right tools

Use the special tools that are advised to protect parts from damage. Use the right tool in the right manner – don't improvise.

##### 2. Tightening torque

Follow the torque tightening instructions. When tightening bolts, nuts and screws, tighten the larger sizes first, and tighten inner positioned fixings before outer positioned ones.

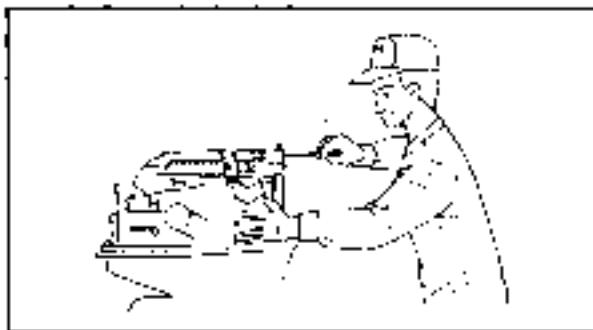
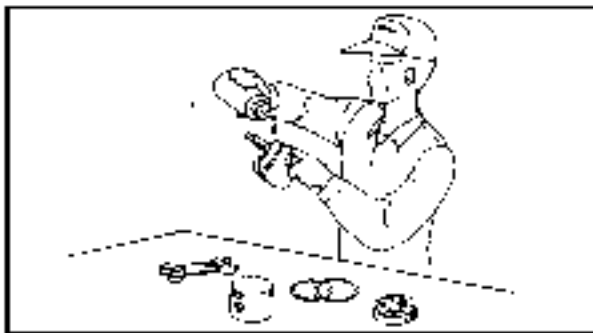

### 3. Nonreusable Items

Always use new gaskets, packings, O-rings, oil seals, split-pins and circlips etc. on reassembly.

### DISASSEMBLY AND ASSEMBLY

1. Clean parts with compressed-air on disassembling them.
2. Oil the contact surfaces of moving parts on assembly.
3. After assembly, check that moving parts operate normally.

4. Install bearings with the manufacturer's markings on the side exposed to view, and liberally oil the bearings.

### **CAUTION:**

**Do not use compressed air to spin the bearings dry. This causes damage to the bearing surfaces.**

5. When installing oil seals, apply a light coating of water-resistant grease to the outside diameter.

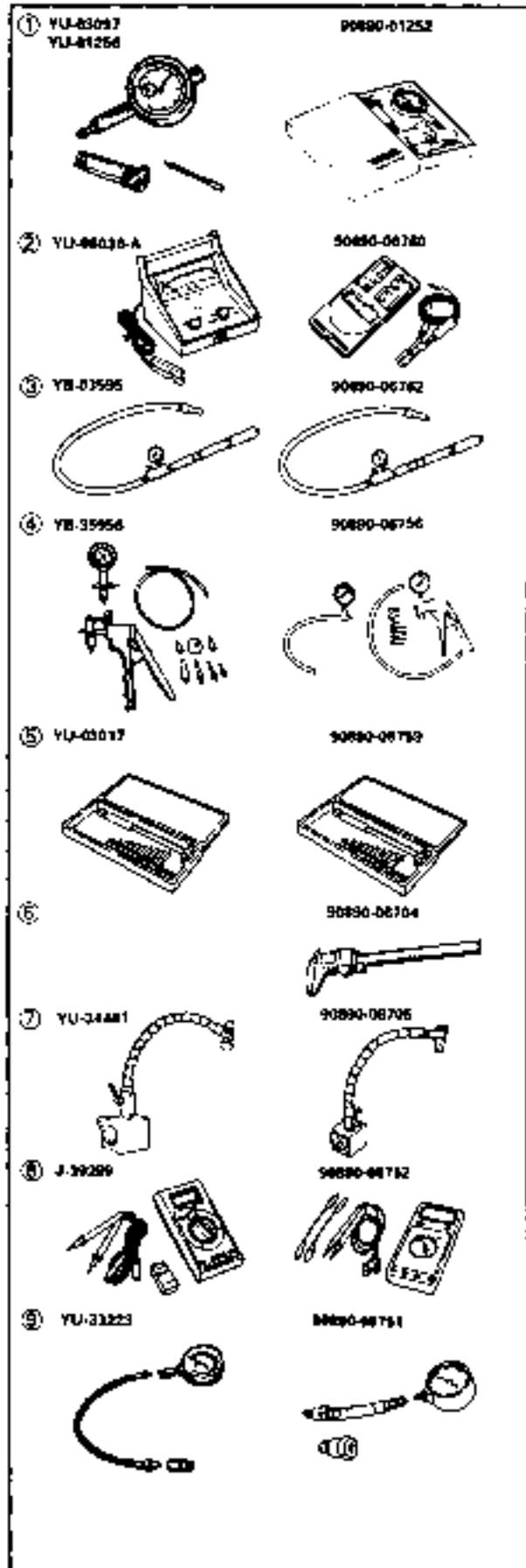

**SPECIAL TOOLS**

The use of correct special tools recommended by Yamaha will aid the work and enable accurate assembly and tune-up. Improvisations and use of improper tools can cause damage to the equipment.

**NOTE:**

•For U.S.A. and Canada, use part number starting with "J-", "YB-", "YM-", "YU-" or "YW-".

•For others, use part number starting with "90890-".

**MEASURING**

1. Dial gauge and stand  
P/N. YU-03097, YU-01256  
90890-01252
2. Tachometer  
P/N. YU-08036-A  
90890-06760
3. Pressure tester  
P/N. YB-03595  
90890-06762
4. Mity vac  
P/N. YB-35956  
90890-06756
5. Cylinder gauge set  
P/N. YU-03017  
90890-06759
6. Digital caliper  
P/N. 90890-06704
7. Magnet base  
P/N. YU-34491  
90890-06705
8. Digital multi meter  
P/N. J-39299  
90890-06752
9. Compression gauge  
P/N. YU-33223  
90890-06751



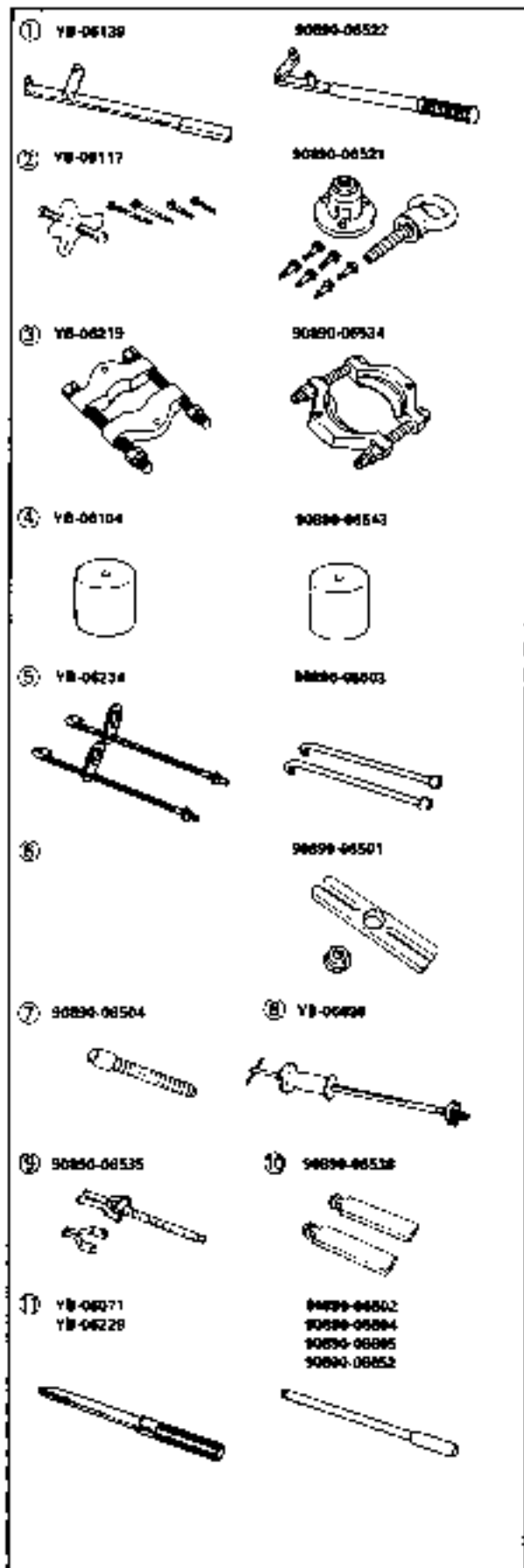

**REMOVAL AND INSTALLATION**

1. Flywheel holder  
P/N. YB-06139  
90890-06522
2. Flywheel puller  
P/N. YB-06117  
90890-06521
3. Bearing separator  
P/N. YB-06219  
90890-06534
4. Small end bearing needle installer  
P/N. YB-06104  
90890-06543
5. Bearing housing puller  
P/N. YB-06234  
90890-06503
6. Stopper guide plate  
(Propeller shaft housing,  
Reverse gear bearing)  
P/N. 90890-06501
7. Center bolt (Propeller shaft housing)  
P/N. 90890-06504
8. Slide hammer set (Reverse gear bearing)  
P/N. YB-06096
9. Bearing puller (Reverse gear bearing)  
P/N. 90890-06535
10. Stopper guide stand (Reverse gear bearing)  
P/N. 90890-06538
11. Driver rod  
P/N. YB-06071, YB-06229  
90890-06602, 90890-06604,  
90890-06605, 90890-06652

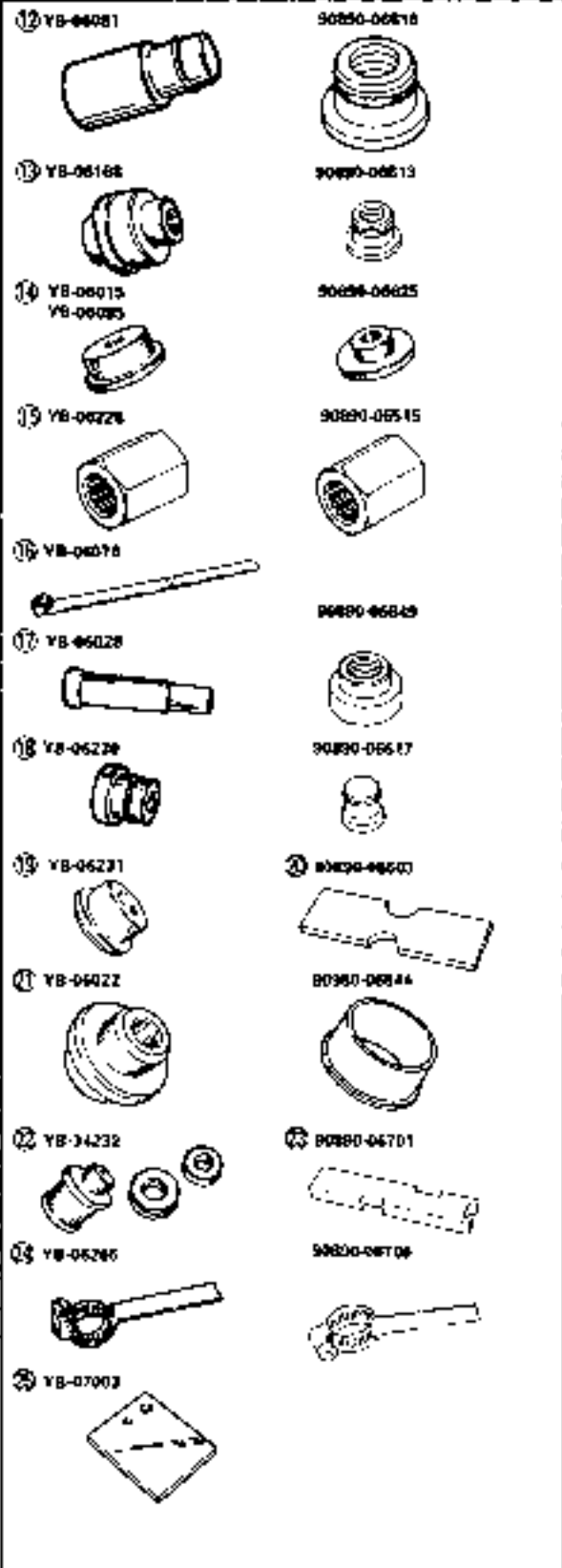

12. Needle bearing attachment  
(Propeller shaft)  
P/N. YB-06081  
90890-06616
13. Oil seal installer (Propeller shaft)  
P/N. YB-06168  
90890-06613
14. Bearing installer  
P/N. YB-06015, (Reverse gear)  
YB-06085 (Forward gear)  
90890-06625 (Forward gear)
15. Drive shaft holder  
P/N. YB-06228  
90890-06515
16. Pinion nut holder  
P/N. YB-06078
17. Bushing attachment  
(Drive shaft housing)  
P/N. YB-06028  
90890-06649
18. Needle bearing attachment  
(Drive shaft)  
P/N. YB-06230  
90890-06617
19. Driver shaft needle bearing depth stop  
P/N. YB-06231
20. Bearing depth plate  
90890-06603
21. Bearing installer  
P/N. YB-06022 (Drive shaft oil seal)  
90890-06644 (Forward gear)
22. Pinion height gauge  
P/N. YB 34232
23. Shimming plate  
P/N. 90890-06701
24. Backlash indicator  
P/N. YB-06285  
90890-06706
25. Backlash adjusting plate  
P/N. YB-07003

---

## **CHAPTER 2 SPECIFICATIONS**

<b>GENERAL SPECIFICATIONS</b> .....	<b>2-1</b>
<b>MAINTENANCE SPECIFICATIONS</b> .....	<b>2-3</b>
ENGINE .....	2-3
LOWER .....	2-4
ELECTRICAL .....	2-5
DIMENSION .....	2-5
<b>TIGHTENING TORQUE</b> .....	<b>2-6</b>
SPECIFIED TORQUE .....	2-8
GENERAL TORQUE .....	2-6



## GENERAL SPECIFICATIONS

Item	Unit	9.9	15
<b>DIMENSION:</b>			
Over-all Length	mm (in)	873 (34.4)	
Over-all Width	mm (in)	332 (13.1)	
Over-all Height	mm (in)	1040 (40.9)	
	S	1167 (45.9)	
	L	1309 (51.5)	
	SUL		
<b>WEIGHT:</b>			
Weight (All)	kg (lb)	36 (79.4)	
	L	37.5 (82.7)	
	SUL	39 (86.0)	
<b>PERFORMANCE:</b>			
Full Throttle Operating Range	r/min	4500-5500	
Output (ISO)	kW (hp) at r/min	7.4 (9.9) / 5000	11.2 (15) / 5000
Maximum Fuel Consumption	L (US gal, Imp gal)/h at r/min	5.1 (1.35, 1.12) at 5500	7.3 (1.93, 1.61) at 5500
<b>ENGINE:</b>			
Type		2 stroke - L	
Cylinders		2	
Total Displacement	cm <sup>3</sup> (cu. in)	246 (15.01)	
Bore X Stroke	mm (in)	56.0 x 50.0 (2.20 x 1.97)	
Compression Ratio		6.80	
Carburetor Quantity		1	
Intake System		Reed Valve	
Induction System		Loop Charge	
Starting System		MH Manual	EMH (EH), EMHR, EMR (ER) Manual & Electric
Control system		MH, EMH (EH) Tiller control	EMHR Tiller & Remote control
Ignition System		CDI	
Alternator Output		MH 12 - 80W	EMH (EH), EMHR 12 - 6A
Enrichment System		Choke Valve	
Advance Type		Mechanical	
Spark Plug	(NGK)	B7HS-10 BR7HS-10	
Exhaust System		Through Prop Boss	
Cooling System		Water	
Lubrication System		Pre-Mixed Fuel & Oil	
<b>FUEL AND OIL:</b>			
Fuel Type		Regular Gasoline	
Engine Oil Type / Grade		2 stroke outboard motor oil / TC-W3	
Gear Oil Type		Hypoid Gear Oil-SAE#90	
Gear Oil Quantity	cm <sup>3</sup> (US oz, Imp oz)	250 (8.45, 8.80)	
Mixing Ratio		100:1 (JPN/GEN 50:1)	

**SPEC****GENERAL SPECIFICATIONS**

Item	Unit	9.9	15
<b>BRACKET:</b>			
Tilt Angle	degrees	8, 12, 16, 20	
Tilt-up Angle	degrees	57	
Shallow Water Crashing Angle	degrees	30, 36	
Steering Angle	degrees (left+right)	45+40	
<b>DRIVE UNIT:</b>			
Gear Shift Position		F-N-R	
Gear Ratio		2.08 (27/13)	
Gear Type		Spiral Bevel Gear	
Clutch Type		Dog clutch	
Propeller Direction		Clockwise	
Propeller Drive System		Spline	
Propeller Series Mark		J	
<b>ELECTRICAL:</b>			
Battery Capacity	Ah (kC)	MH	EMH (EH), EMHA, EMR (ER)
Cold Cranking	Amps	-	40 (144)
		-	210



## MAINTENANCE SPECIFICATIONS

## ENGINE

Item	Unit	9.9	15
<b>CYLINDER HEAD:</b> Warpage limit	mm (in)	0.1 (0.004)	
<b>CYLINDER:</b> Bore size	mm (in)	56.00-56.02 (2.205-2.206)	
Wear limit	mm (in)	56.1 (2.21)	
Taper limit	mm (in)	0.08 (0.003)	
Out of round limit	mm (in)	0.05 (0.002)	
<b>PISTON:</b> Piston clearance Limit	mm (in)	0.035-0.040 (0.0014-0.0016) 0.090 (0.0035)	
Diameter	mm (in)	55.940-55.985 (2.2024-2.2041)	
Measuring point	mm (in)	10 (0.39)	
Pin boss inside diameter	mm (in)	14.004-14.015 (0.5513-0.5518)	
Ring groove clearance	mm (in)	0.02-0.06 (0.001-0.002)	
	top	0.04-0.08 (0.002-0.003)	
	2nd	56.25 (2.215)	
Over size diameter	mm (in)	56.50 (2.224)	
	1st*1		
	2nd		
<b>PISTON PIN</b> Diameter	mm (in)	13.996-14.000 (0.5510-0.5512)	
<b>PISTON RING: 1st</b> Type		Keystone	
Dimensions	mm (in)	2.0x2.5 (0.08x0.10)	
End gap	mm (in)	0.15-0.35 (0.006-0.014)	
Limit	mm (in)	0.55 (0.022)	
<b>PISTON RING: 2nd</b> Type		Barrel	
Dimensions	mm (in)	2.0x2.5 (0.08x0.10)	
End gap	mm (in)	0.15-0.35 (0.006-0.014)	
Limit	mm (in)	0.55 (0.022)	
<b>CONNECTING ROD:</b> Small end diameter	mm (in)	18.000-18.011 (0.7087-0.7091)	
<b>CRANK SHAFT:</b> Crank width	mm (in)	46.90-46.95 (1.846-1.848)	
Runout limit	mm (in)	25.90-26.10 (1.020-1.028)	
Big end side clearance	mm (in)	0.03 (0.001)	
Maximum small end axial play	mm (in)	0.30-0.80 (0.012-0.031) 2.0 (0.08)	
<b>THERMOSTAT:</b> Opening temperature	°C (°F)	48-52 (118-126)	
Full-opening temperature	°C (°F)	60 (140)	
Valve lift	mm (in)	3 (0.12)	
<b>REED VALVE:</b> Valve stopper height	mm (in)	0.7±0.1 (0.03±0.00)*2	6.0±0.1 (0.24±0.00)
Valve warpage limit	mm (in)	1.3±0.1 (0.05±0.00)*3	0.2 (0.01)

\*1: Except for USA

\*2: Except for Europe

\*3: For Europe



Item	Unit	9.9	15
<b>CARBURETOR:</b>			
Identification mark		63V00	
Floet height	mm (in)	14.0-1.5 (0.55±0.05)	
Valve seat size	mm (in)	1.2 (0.05)	
Main jet (M.J.)	✱	110	
Main nozzle (M.N.)	mm (in)	3.0 (0.12)	
Main air jet (M.A.J.)	✱	120	
Pilot jet (P.J.)	✱	48	
Pilot air jet (P.A.J.)	✱	75	
Pilot screw (P.S.)	turns out	1-1/2±1/4	
<b>ENGINE SPEED</b>			
Idle speed	r/min	750±50	
Trolling speed	r/min	650±50	
<b>RECOIL STARTER:</b>			
Starter rope length	mm (in)	1800 (70.9)	

**LOWER**

Item	Unit	9.9	15
<b>GEAR BACKLASH:</b>			
Pinion - Forward	mm (in)	0.19-0.86 (0.007-0.034)	
Pinion - Reverse	mm (in)	0.95-1.65 (0.037-0.065)	
Pinion shims	mm	1 1.3, 1.2	
Forward shims	mm	0.10, 0.12, 0.15, 0.18, 0.30, 0.40, 0.50	
Reverse shims	mm	0.1, 0.2, 0.3, 0.4, 0.5	
<b>PROPELLER:</b>			
Material		Aluminum	Dual thrust
Blade x Diameter x Pitch	in	3 x 9-1/4 x 8 -J 3 x 9-1/4 x 9 -J 3 x 9-1/4 x 9-3/4 -J 3 x 9-1/4 x 10-1/2 -J 3 x 9-1/4 x 12 -J 3 x 9-1/2 x 6-1/2 -J	683-45947-12 00 3 x 9-3/4 x 8 -J 683-45949-12 01 3 x 9-3/4 x 6-1/2 -J
Test propeler (except for USA and Canada)		90890-01619	
	r/min	5000-5200	5200-5400
(for USA and Canada)		Y6-01619	
	r/min	5000-5200	5200-5400



## ELECTRICAL

Item	Unit	9.9	15
<b>IGNITION SYSTEM:</b>			
Ignition timing (full retard)	degrees	A.T.D.C. 5±1	
(full advanced)	degrees	B.T.D.C. 30±1	
Piston position (full retard)	mm (in)	A.T.D.C. 0.12±0.04 (0.005±0.002)	
(full advanced)	mm (in)	B.T.D.C. 4.22 +0.28 -0.27 (0.166 +0.011 -0.011)	
Pulser coil resistance	Ω(color)	352-528 (W/R-B)	
Charge coil resistance	Ω(color)	248-372 (B-L)	
Ignition coil resistance			
primary coil	Ω(color)	0.05-0.07 (B/W-B)	
secondary coil	kΩ(color)	1.68-2.52 (B/W-High tension cord)	
Spark plug gap	mm (in)	0.9-1.0 (0.035-0.039)	
Charging current (minimum)	A at r/min	1.9-4.9/3000	
(maximum)	A at r/min	4.7-7.7/5500	
<b>STARTING SYSTEM:</b>			
Fuse	V-A	MH	EMH (EH), EMHR, EMR (ER)
Neutral switch on	mm (in)	—	12-20
off	mm (in)	—	18.5-19.5 (0.73-0.77)
		—	19.5-20.5 (0.77-0.81)
<b>STARTER MOTOR:</b>			
Type		MH	EMH (EH), EMHR, EMR (ER)
Output	kW	—	Bendix
Brush length	mm (in)	—	0.4
Wear limit	mm (in)	—	7.5 (0.30)
Commutator diameter	mm (in)	—	4.5 (0.18)
Limit	mm (in)	—	20.0 (0.79)
Clutch type		—	19.4 (0.76)
Rating	Sec	—	Over running
			30
<b>CHARGING SYSTEM:</b>			
Lighting coil resistance	Ω(color)	0.16-0.24 (G-G)	
Lighting voltage (minimum)	V at r/min	11.5/3000	
Lighting voltage (maximum)	V at r/min	14-17.5/5500	

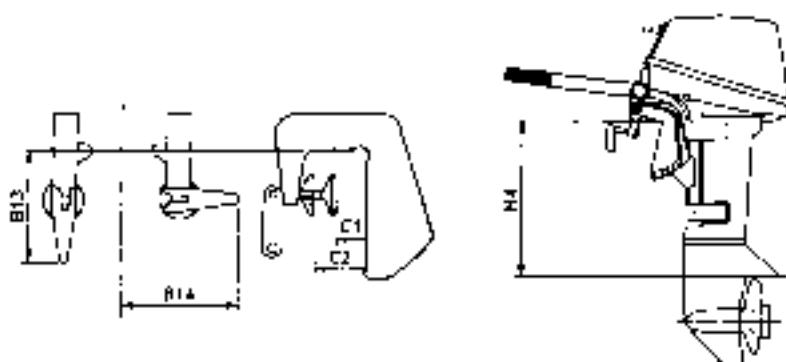

## DIMENSION

Symbol	Unit	9.9	15
H4	:S	mm (in)	440 (17.3)
	:L	mm (in)	567 (22.3)
	:SUL	mm (in)	709 (27.9)
B13		mm (in)	134 (5.3)
B14		mm (in)	133.5 (5.3)
C1		mm (in)	31 (1.2)
C2		mm (in)	64 (2.5)





## TIGHTENING TORQUE

## SPECIFIED TORQUE

Part to tightened	Part name	Thread size	Q'ty	Tightening torque			Remarks
				Nm	m•Kg	ft•lb	
<b>ENGINE:</b>							
Flywheel	Nut	M12	1	105	10.5	75	
Spark plug	Bolt	M14	2	25	2.5	18	
Cylinder head	1st	Bolt	11	8	0.8	5.8	
	2nd			17	1.7	12	
Exhaust cover	1st	Bolt	13	5.0	0.6	4.3	
	2nd			12	1.2	8.7	
Crank case	1st	Bolt	6	15	1.5	11	
	2nd			30	3.0	22	
<b>LOWER:</b>							
Propeller	Nut	M10	1	17	1.7	12	
Pinion nut	Nut	M8	1	26	2.6	19	
<b>BRACKET:</b>							
Clamp bracket	Nut	7/8 UNF	2	13	1.3	9.4	
Upper rubber mounting	Nut	M8	2	21	2.1	15	
Lower front rubber mounting	Nut	M6	4	13	1.3	9.4	

Nut (A)	Bolt (B)	General torque specifications		
		Nm	m•kg	ft•lb
8 mm	M5	5.0	0.5	3.8
10 mm	M6	8.0	0.8	5.8
12 mm	M8	18	1.8	13
14 mm	M10	36	3.6	25
17 mm	M12	43	4.3	31

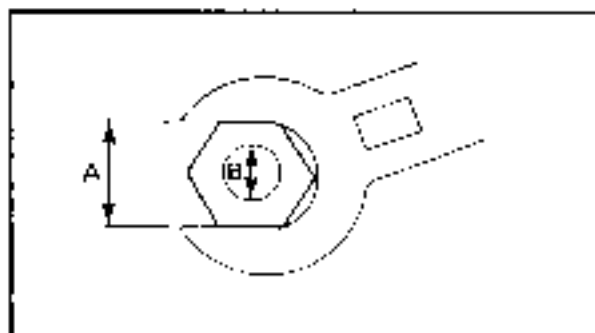

## GENERAL TORQUE

This chart specifies the torques for tightening standard fasteners with standard clean dry ISO threads at room temperature. Torque specifications for special components or assemblies are given in applicable sections of this manual. To avoid causing warpage, tighten multifastener assemblies in crisscross fashion, in progressive stages until the specified torque is reached.

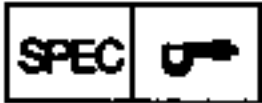

## CHAPTER 3 PERIODIC INSPECTION AND ADJUSTMENT

<b>MAINTENANCE INTERVAL CHART</b> .....	3-1
<b>PERIODIC SERVICE</b> .....	3-2
<b>FUEL SYSTEM</b> .....	3-2
Fuel line .....	3-2
<b>CONTROL SYSTEM</b> .....	3-2
Ignition timing adjustment .....	3-2
Throttle link adjustment .....	3-4
Start-in-gear protection adjustment .....	3-5
Idle speed adjustment .....	3-5
<b>LOWER UNIT</b> .....	3-6
Gear oil .....	3-6
Lower unit leakage check .....	3-7
<b>GENERAL</b> .....	3-7
Anode .....	3-7
Battery .....	3-8
Spark plug .....	3-9
Greasing point .....	3-10



## MAINTENANCE INTERVAL CHART

The following chart should be considered strictly as a guide to general maintenance intervals. Depending on operating conditions, the intervals of maintenance should be changed.

Item	Remarks	Initial		Every		Refer page
		10 hours (Break-in)	50 hours (3 months)	100 hours (6 months)	200 hours (1 year)	
<b>COWLING:</b>						
Cowling clamp	Inspection				○	-
<b>FUEL SYSTEM:</b>						
Fuel line	Inspection	○		○	○	3-2
Fuel filter	Cleaning	○	○	○		4-2
Carburetor	Cleaning	○	○	○		4-7
<b>POWER UNIT:</b>						
Water leakage	Inspection	○	○	○		-
Motor exterior	Inspection	○	○	○		-
Exhaust leakage	Inspection	○	○	○		-
Cooling water passage	Cleaning		○	○		-
<b>CONTROL SYSTEM:</b>						
Ignition timing	Inspection/Adjustment	○		○		3-2
Throttle link	Inspection/Adjustment				○	3-4
Throttle cable	Inspection/Adjustment				○	3-4
Start-in-gear protection	Inspection/Adjustment	○		○		3-5
Idle speed	Inspection/Adjustment	○		○		3-5
<b>LOWER UNIT:</b>						
Gear oil	Change	○		○		3-8
Lower unit leakage	Inspection				○	3-7
Propeller	Inspection	○	○	○		6-2
<b>GENERAL:</b>						
Anode	Inspection		○	○		3-7
Battery	Inspection	○	○	○		3-8
Spark plug	Cleaning/Adjustment/ Replacement	○	○	○		3-9
Wiring and connector	Adjustment/Reconnect	○	○	○		-
Bolts and nuts	Retightening	○	○	○		-
Grease points	Greasing			○		3-10



## PERIODIC SERVICE FUEL SYSTEM

### Fuel line

- Inspect:
  - Fuel line  
Break/Leak/Damage → Replace.

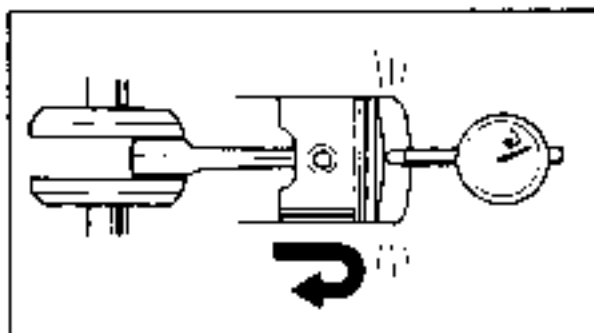
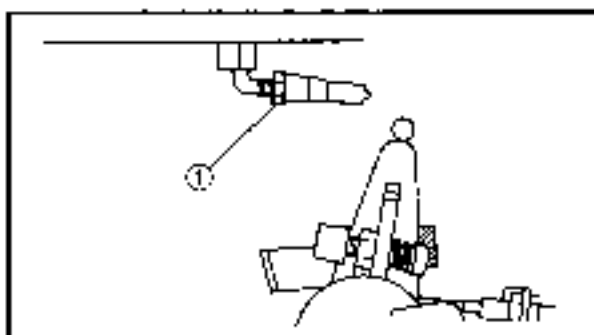
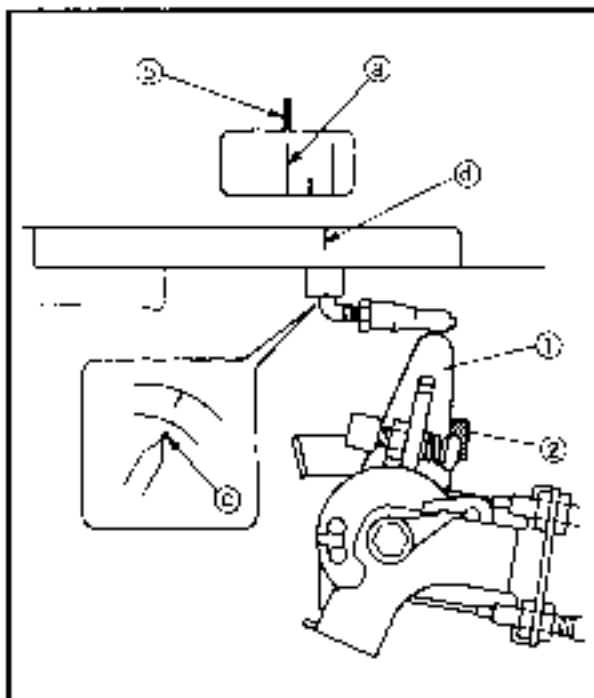

## CONTROL SYSTEM

### Ignition timing adjustment

- Check:
  - Fully advanced ignition timing  
Incorrect → Adjust.

#### Checking steps:

- Turn the flywheel clockwise so that its specified marking 'a' aligns with the starter cover marking 'b'.



#### Fully advanced position:

30° BTDC

- Turn the magneto control lever (1) so that it contacts the fully advanced stopper (2).
- Check the timing indicator (3) so that it aligns with the marking 'd' on the flywheel.

- Adjust:
  - Link joint

#### Adjustment steps:

- Loosen the lock nut (1).
- Disconnect the link joint from the magneto control lever.
- Remove the spark plug of No. 1 cylinder
- Attach the dial gauge to the spark plug hole.



#### Dial gauge:

YU-03097 / 90890-01252

#### Dial gauge stand:

YU-01256

- Slowly turn the flywheel clockwise until the piston reaches top dead center (TDC).

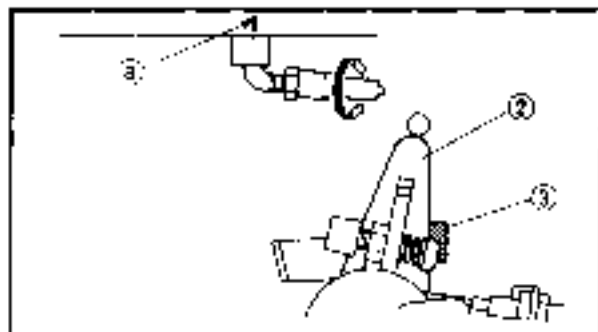

- Set the dial gauge to zero at TDC.
- Turn the flywheel counterclockwise until the dial gauge indicates that the piston position is at a specified distance from TDC.



**Piston position:**

**4.22 mm (0.166 in) BTDC**

- Turn the magneto control lever ② so that it contacts the fully advanced stopper ③.
- Adjust the link joint length so that the timing indicator aligns with the marking 'a' on the flywheel.
- Tighten the lock nut.

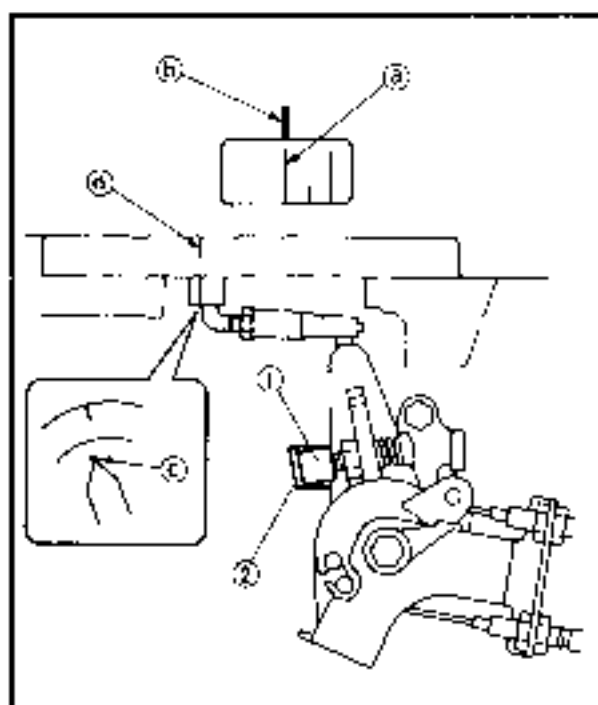

3. Check:
- Fully retard ignition timing  
Incorrect → Adjust.

**Checking steps:**

- Turn the flywheel clockwise so that the its specified marking 'a' aligns with the starter cover marking 'b'.



**Fully retard position:**

**5° ATDC**

- Turn the magneto control lever so that the fully retard screw ① contacts the fully retard stopper ②.
- Check the timing indicator ③ so that it aligns with the marking 'd' on the flywheel.

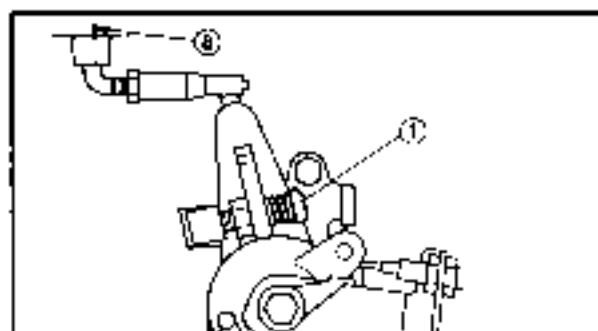

4. Adjust:
- Fully retard screw

**Adjustment steps:**

- Turn the flywheel clockwise until the dial gauge indicates that the piston position is at specified distance from TDC.



**Piston position:**

**0.12 mm (0.005 in) ATDC**



- Turn the magneto control lever so that the fully retard screw contacts the fully retard stopper.
- Adjust the fully retard screw (1) so that the timing indicator aligns with the marking (a) on the flywheel.

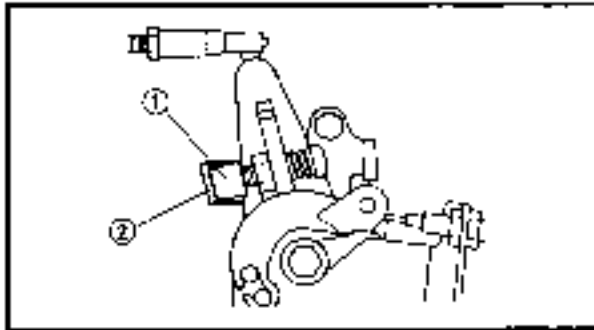

### Throttle link adjustment

#### NOTE:

Before adjusting the throttle link, the ignition timing should be adjusted.

1. Inspect:
  - Fully closed position  
Incorrect - Adjust.

#### Checking steps:

- Close the throttle grip fully.
- Check the fully retard screw (1) so that it contacts the fully retard stopper (2).

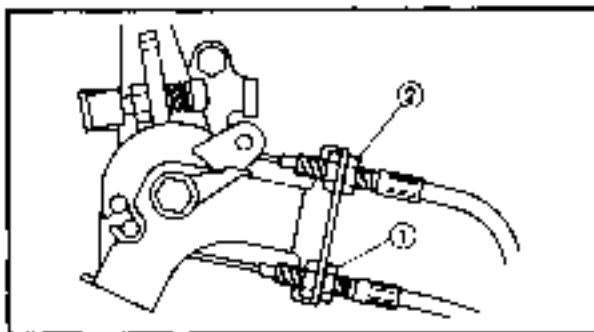

2. Adjust:
  - Throttle cable adjuster

#### Adjustment steps:

- Loosen the lock nuts (1), (2).
- Turn the magneto control lever until the fully retard screw contacts the fully retard stopper.
- Adjust the throttle cable adjuster until there is specified free play between the stoppers of the pulley (3) and free acceleration lever (4).



#### Free play:

1 mm (0.04 in)

- Tighten the lock nut (1).

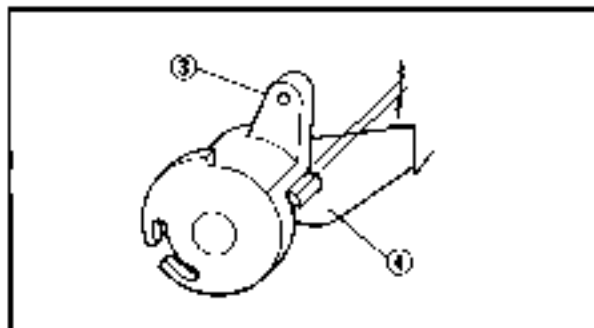

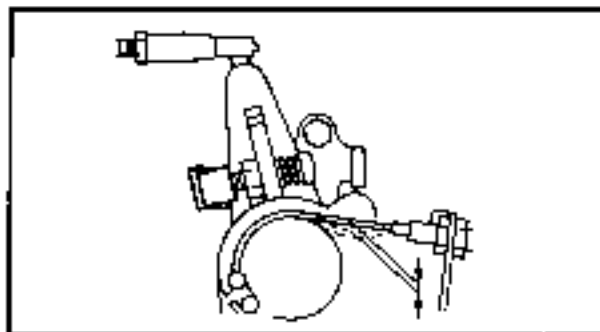

- Adjust the throttle cable adjuster until there is specified free play on the throttle cable.

**Free play:**

1 mm (0.04 in)

- Tighten the lock nut (2).

## 3. Check:

- Throttle operation  
Rough operation → Repair.

**Start-in-gear protection adjustment**

## 1. Check:

- Start in-gear protection operation  
Incorrect → Adjust.

## 2. Adjust:

- Start-in-gear protection wire

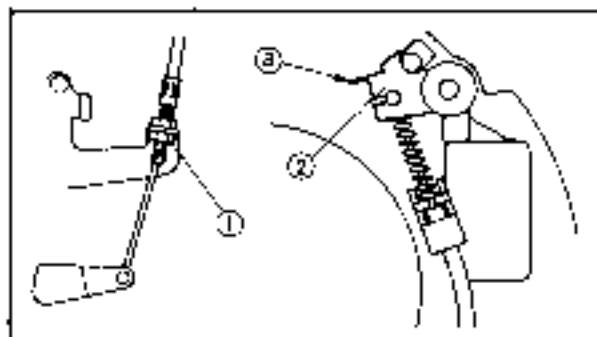
**Adjustment steps:**

- Set the shift lever in neutral.
- Loosen the lock nut (1)
- Adjust the start-in-gear protection wire adjuster so that the end of the stopper (2) aligns with the marking (a) of the starter case.
- Tighten the lock nut.

**Idle speed adjustment****NOTE:**

Before adjusting the idle speed, be sure to adjust the throttle link.

## 1. Measure:

- Idle speed  
Out of specification → Adjust

**Idle speed:**

750 ± 60 rpm

**Measuring steps:**

- Start the engine and allow it to warm up for a few minutes.
- Attach the tachometer to the high tension lead of the cylinder #1.

**Tachometer:**

YU-08036-A / 90890-06760



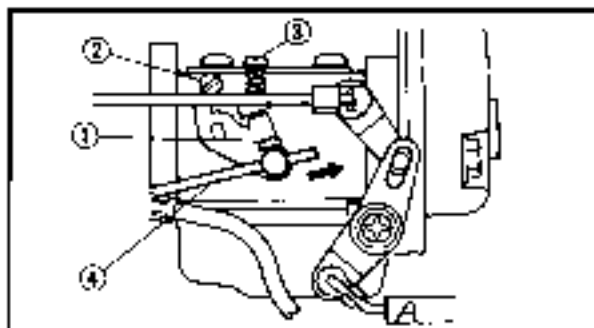

2. Adjust:
- Idle speed

**Adjustment steps:**

- Loosen the screw ① of the carburetor throttle lever.
- Turn in the pilot screw ② until it is lightly seated.
- Turn out the pilot screw to specification.

**Pilot screw (turns out):**

$1-1/2 \pm 1/4$

- Adjust the throttle stop screw ③ in or out until specified idle speed is obtained.

**Turning in → Idle speed becomes higher.**

**Turning out → Idle speed becomes lower.**

- Pull the acceleration rod ④ until the fully retard screw contacts the fully retard stopper.
- Tighten the screw ①.

**Screw:**

$1 \text{ Nm (0.1 m}\cdot\text{kg, 0.7 ft}\cdot\text{lb)}$

**LOWER UNIT****Gear oil**

1. Check:
  - Gear oil
    - Milky oil → Replace the oil seal.
    - Slag oil → Check the gear, bearing and dog.
2. Check:
  - Gear oil level
    - Oil level is low → Add oil to proper level.
3. Replace:
  - Gear oil

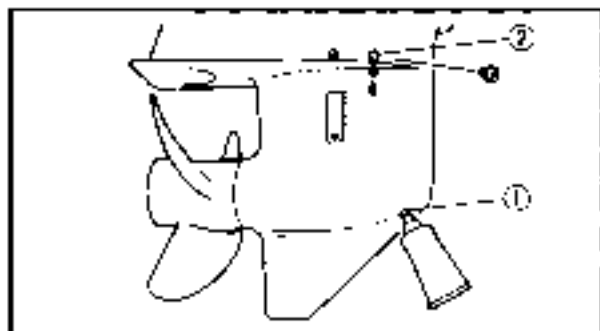
**Replacement steps:**

- Tilt up the motor.
- Place a pan under the drain plug ①.
- Remove the drain plug, then the oil level plug ② and drain the oil thoroughly.
- Place the outboard motor in an upright position.



- Fill the gear oil through the drain hole until it overflows at the level hole.



**Recommended oil:**

**GEAR CASE LUBE (USA) or Hypoid gear oil, SAE #90**

**Oil capacity:**

**250 cm<sup>3</sup> (8.45 US oz, 8.80 Imp oz)**

- Refit the oil level plug and then oil drain plug.

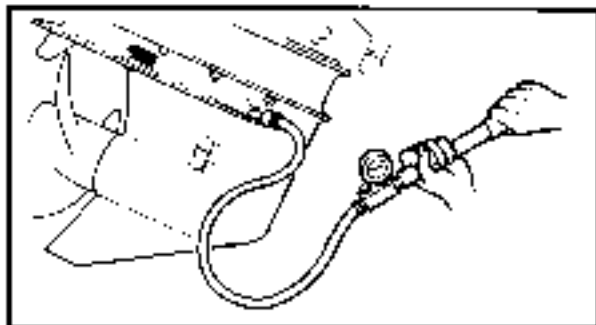

**Lower unit leakage check**

1. Check:

- Pressure holding  
Pressure falls → Inspect seals and component parts.

**Checking steps:**

- Attach the tester to the oil-level hole.



**Pressure tester:**

**YB-03595/90890-06762**

- Apply the specified pressure.



**Pressure:**

**100 kPa (1.0 kg/cm<sup>2</sup>, 14.2 psi)**

- Check that the pressure is held as specified for 10 seconds.

**NOTE:**

Do not over-pressurize. Excess pressure may cause the air to leak out.

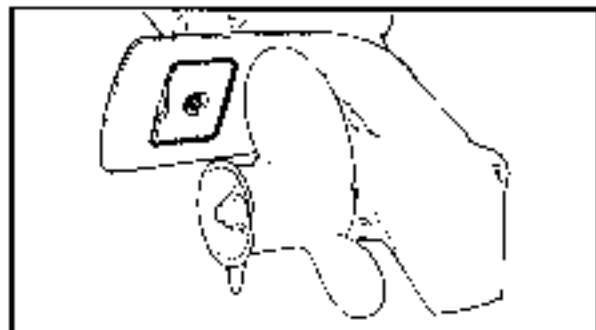

**GENERAL**

**Anode**

1. Inspect:

- Anode  
Scale → Clean.  
Oil/grease → Clean.  
Wear/Excessively consumed → Replace.

**CAUTION:**

Do not oil, grease or paint the anode, or the function of the sacrificial anode will be spoiled.

**Battery**
**⚠ WARNING**

Battery electrolyte is poisonous and dangerous, causing severe burns, etc. It contains sulfuric acid. Avoid contact with skin, eyes, or clothing.

**Antidote:**

**EXTERNAL;** Flush with water.

**INTERNAL;** Drink large quantities of water or milk. Follow with milk of magnesia, beaten egg, or vegetable oil. Call physician immediately.

**EYES;** Flush with water for 15 minutes and get prompt medical attention.

**Batteries produce explosive gases:** Keep sparks, flame, cigarettes, etc. away. Ventilate when charging or using in a closed space. Always wear eye protection when working near batteries.

**KEEP OUT OF REACH OF CHILDREN.**

---

**NOTE:**

- Batteries vary among manufacturers. Therefore the following procedures may not always apply. Consult your battery manufacturer's instructions
  - Disconnect the black negative lead first to prevent the risk of shorting.
- 

**1. Inspect:**

- Battery fluid level
- Battery fluid specific gravity

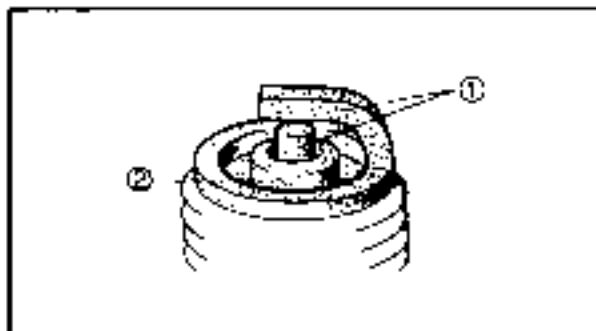

**Spark plug**

1. Inspect:
  - Electrode ①  
Wear/Damage → Replace.
  - Insulator color ②  
Distinctly different color → Check the engine condition.



**Color guide**

- Medium to light tan color:**  
Normal
- Whitish color:** Lean fuel mixture  
Plugged fuel mixture  
Air leak  
Wrong settings
- Blackish color:** Overly rich mixture  
Electrical malfunction  
Excess oil used  
Defective spark plug

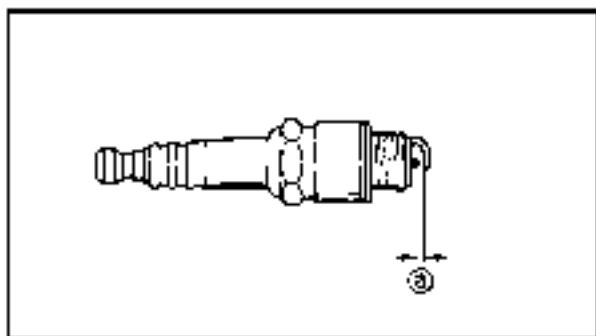

2. Clean:
  - Spark plug  
Clean the spark plug with a spark plug cleaner or wire brush.
3. Measure:
  - Spark plug gap a  
Out of specification → Alter gap.  
Use a wire gauge.



**Spark plug gap:**

0.9 - 1.0 mm (0.035 - 0.039 in)

4. Tighten:
  - Spark plug



**Spark plug:**

25 Nm (2.5 m · kg, 18 ft · lb)

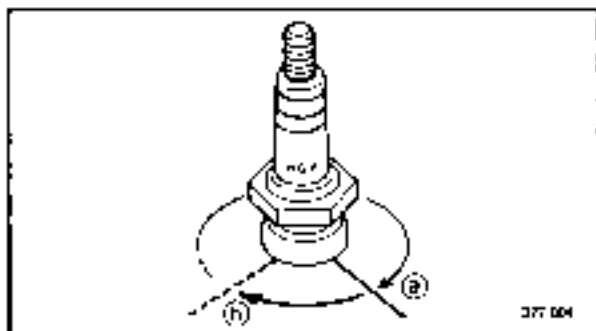

- NOTE:**
- Before installing a spark plug, clean the gasket surface and plug surface. Also it is suggested to apply a thin film of Anti Seize Compound to the spark plug threads to prevent future thread seizure.
  - If a torque wrench is not available, a good estimate of the correct torque is a further 1/4 to 1/2 turns (b) on finger tightened (a) spark plug.

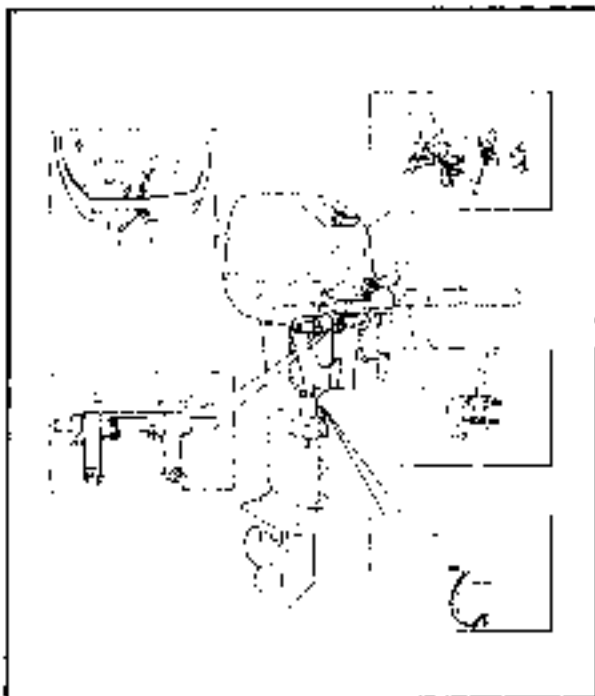

**Greasing point**

**1. Apply:**

- Water resistant grease





## CHAPTER 4 FUEL SYSTEM

<b>FUEL JOINT AND FUEL FILTER</b> .....	4-1
EXPLODED DIAGRAM .....	4-1
REMOVAL AND INSTALLATION CHART .....	4-2
<b>SERVICE POINTS</b> .....	4-2
Fuel joint inspection .....	4-2
Fuel filter inspection .....	4-2
 <b>CARBURETOR REMOVAL</b> .....	 4-3
EXPLODED DIAGRAM .....	4-3
REMOVAL AND INSTALLATION CHART .....	4-4
 <b>CARBURETOR</b> .....	 4-5
EXPLODED DIAGRAM .....	4-5
REMOVAL AND INSTALLATION CHART .....	4-6
<b>SERVICE POINTS</b> .....	4-7
Carburetor inspection .....	4-7
Fuel pump inspection .....	4-7
Carburetor assembly .....	4-8



FUEL JOINT AND FUEL FILTER  
EXPLODED DIAGRAM

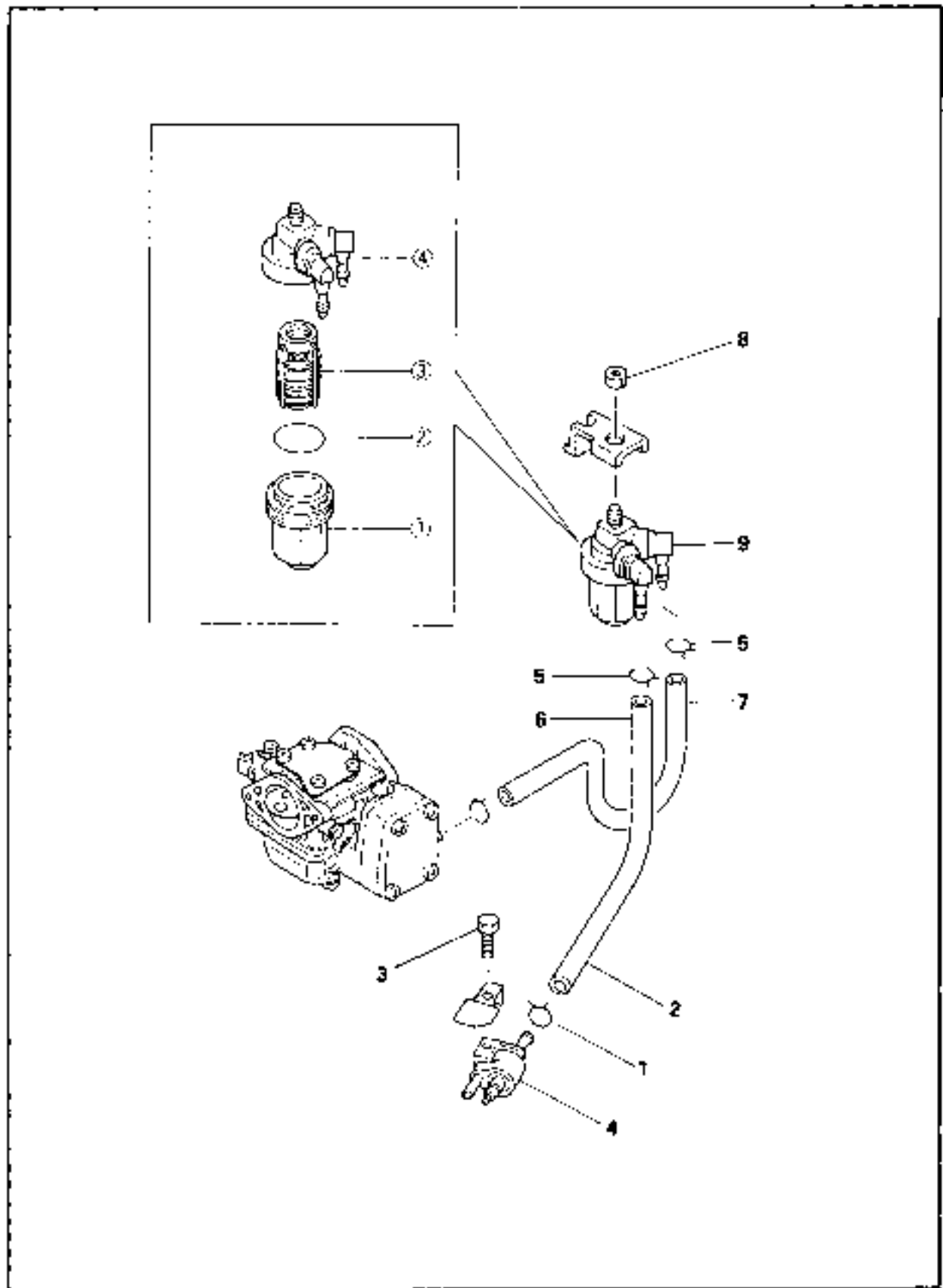





**REMOVAL AND INSTALLATION CHART**

Step	Procedure/Part name	Qty	Service points
<b>FUEL JOINT AND FUEL FILTER</b>			Follow the left "Step" for removal
<b>REMOVAL</b>			
1	Clip	1	
2	Fuel hose (joint - filter)	1	
3	Bolt (with washer)	1	
4	Fuel joint	1	
5	Clip	2	
6	Fuel hose (joint - filter)	1	
7	Fuel hose (filter - carburetor)	1	
8	Nut	1	
9	Fuel filter	1	
<b>FUEL FILTER DISASSEMBLY</b>			
①	Filter cup	1	
②	O-ring	1	
③	Filter element	1	
④	Body cover	1	
			Reverse the removal steps for installation.

**SERVICE POINTS**

**Fuel joint inspection**

- Inspect:
  - Fuel joint  
Crack/Leak/Damage → Replace.
- Measure:
  - Fuel joint operation  
Impossible to maintain the specified pressure for 10 sec. → Replace.

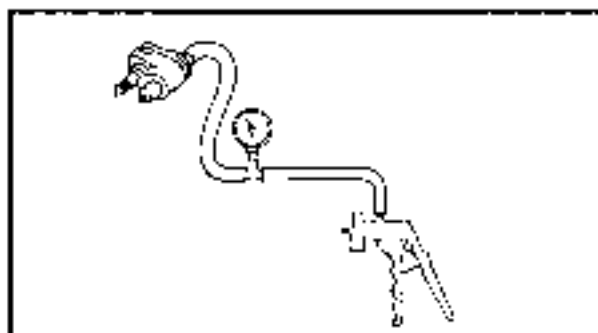

**Measuring steps:**

- Attach the Mity vac.



**Mity vac:**

**YB-35956/90890-06756**

- Apply the specified pressure.



**Specified pressure:**

**50 kPa (0.5 kg/cm<sup>2</sup>, 7.1 psi)**

**Fuel filter inspection**

- Inspect:
  - Filter element
  - Filter cup  
Crack/Leak/Clog → Replace.  
Contamination → Clean.



**CARBURETOR REMOVAL**  
EXPLODED DIAGRAM

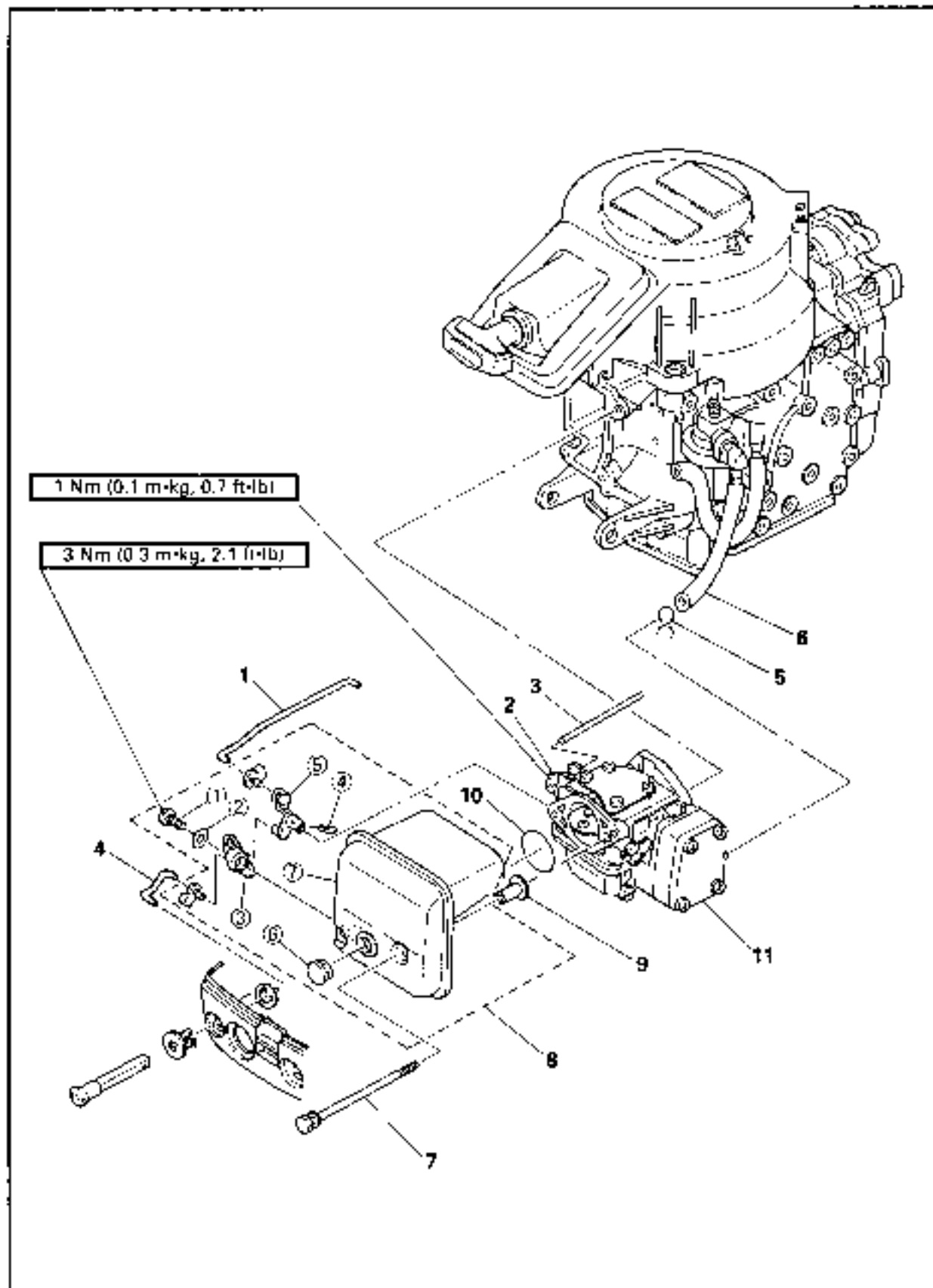



## REMOVAL AND INSTALLATION CHART

Step	Procedure/Part name	Q'ty	Service points
<b>CARBURETOR REMOVAL</b>			Follow the left "Step" for removal.
1	Choke rod	1	
2	Screw	1	
3	Acceleration rod	1	
4	Choke knob rod	1	
5	Clip	1	
6	Fuel hose	1	
7	Bolt (with washer)	2	
8	Silencer assembly	1	
9	Collar	2	
10	O-ring	1	
11	Carburetor assembly	1	
<b>SILENCER DISASSEMBLY</b>			Reverse the removal steps for installation.
①	Tapping screw	1	
②	Plane washer	1	
③	Choke lever joint	1	
④	Spring pin	1	
⑤	Choke lever	1	
⑥	Fogging hole grommet	1	
⑦	Silencer	1	

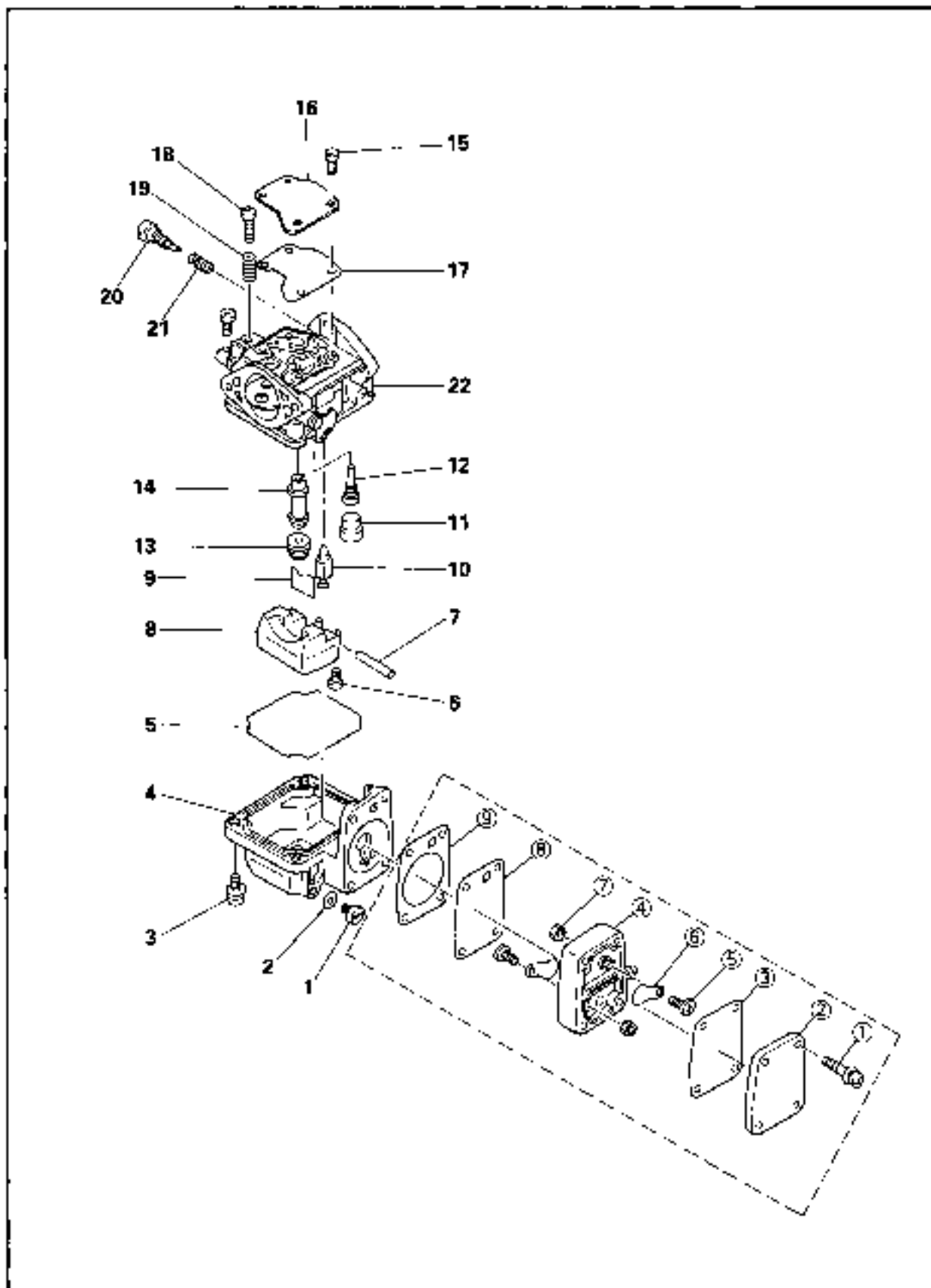
**CARBURETOR  
EXPLODED DIAGRAM**



## REMOVAL AND INSTALLATION CHART

Step	Procedure/Part name	Qty	Service points
	<b>CARBURETOR DISASSEMBLY</b>		Follow the left "Step" for removal.
	Carburetor assembly		Refer to the "CARBURETOR REMOVAL" section in chapter 4.
1	Drain screw	1	
2	Washer	1	
3	Screw (with washer)	4	4 x 14 mm
4	Float chamber	1	
5	Float chamber packing	1	
6	Screw	1	
7	Arm pin	1	
8	Float	1	
9	Clip	1	
10	Needle valve	1	
11	Cap	1	
12	Pilot jet	1	
13	Main jet	1	
14	Main nozzle	1	
15	Screw (with washer)	4	4 x 10 mm
16	Plate	1	
17	Packing	1	
18	Stopping screw	1	
19	Spring	1	
20	Pilot adjusting screw	1	
21	Spring	1	
22	Carburetor body	1	
	<b>FUEL PUMP DISASSEMBLY</b>		
①	Screw (with washer)	4	
②	Pump cover	1	
③	Diaphragm	1	
④	Pump body	1	
⑤	Screw	2	
⑥	Seat valve	2	
⑦	Nut	2	
⑧	Diaphragm	1	
⑨	Diaphragm gasket	1	
			Reverse the removal steps for installation.



## SERVICE POINTS

### NOTE:

Do not use steelwire for cleaning the jets as this may enlarge the jet diameters and seriously affect performance.

### Carburetor inspection

1. Inspect:
  - Carburetor body  
Crack/Damage → Replace.  
Contamination → Clean.
2. Inspect:
  - Pilot screw  
Bend/Wear → Replace.
3. Inspect:
  - Main jet
  - Pilot jet
  - Main nozzle  
Contamination → Replace.
4. Inspect:
  - Needle valve  
Grooved wear → Replace.
5. Inspect:
  - Float  
Crack/Damage → Replace.

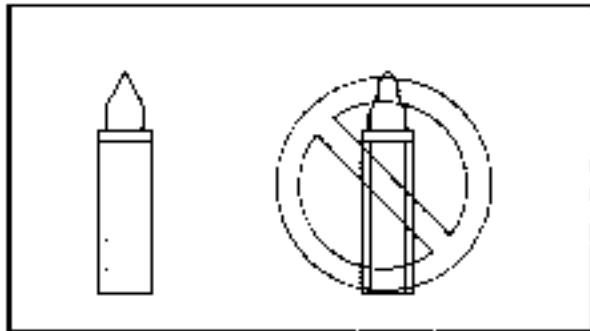

### Fuel pump inspection

1. Inspect:
  - Body  
Crack/Leak/Damage → Replace.
2. Inspect:
  - Seat valve  
Crack/Distortion → Replace.
3. Inspect:
  - Diaphragm  
Damage → Replace.

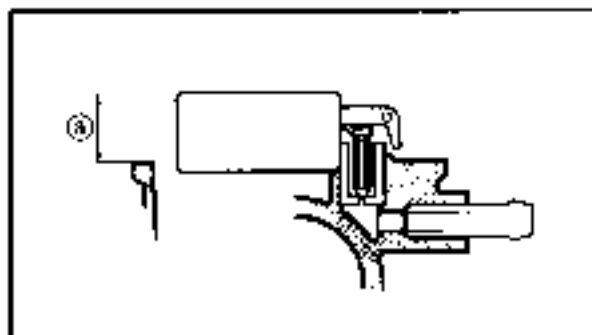
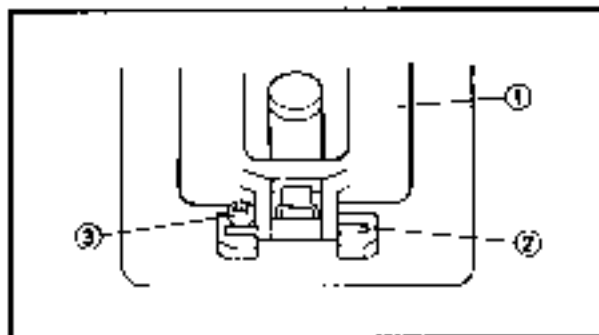

### Carburetor assembly

#### 1. Install:

- Needle valve
- Float (1)
- Float pin (2)
- Screw (3)

#### NOTE:

- The float pin should be fit in the slit the carburetor and locked with the screw.
- After installing, check the smooth movement of the float.

#### 2. Measure:

- Float height (4)  
Out of specification → Replace.



#### Float height (4):

$14.0 \pm 1.5 \text{ mm (} 0.55 \pm 0.06 \text{ in)}$

#### NOTE:

- The float should be resting on the needle valve, but not compressing the needle valve.
- Take measurement at the end surface of the float opposite to its pivoted side.

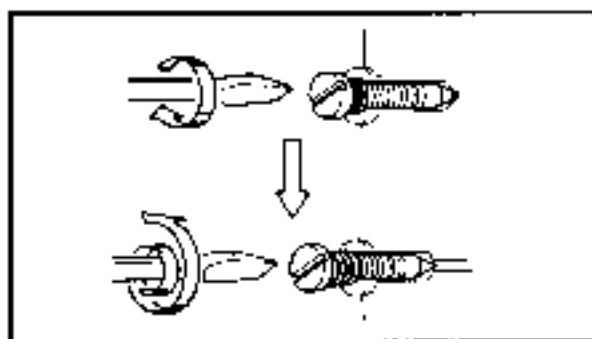

#### 3. Adjust:

- Pilot screw

#### Adjustment steps:

- Screw in the pilot screw until it is lightly seated
- Back out by the specified number of turns.



#### Pilot screw:

$1\text{-}1/2 \pm 1/4 \text{ (turns out)}$







## CHAPTER 5 POWER UNIT

<b>POWER UNIT REMOVAL</b> .....	5-1
EXPLODED DIAGRAM .....	5-1
REMOVAL AND INSTALLATION CHART .....	5-2
<b>RECOIL STARTER</b> .....	5-3
EXPLODED DIAGRAM .....	5-3
REMOVAL AND INSTALLATION CHART .....	5-4
SERVICE POINTS .....	5-5
Sheave drum removal .....	5-5
Spiral spring removal .....	5-5
Starter stopping plunger inspection .....	5-5
Drive pawl and spring inspection .....	5-5
Bushing inspection .....	5-5
Sheave drum inspection .....	5-6
Spiral spring inspection .....	5-6
Starter rope inspection .....	5-6
Recoil starter checking .....	5-6
<b>FLYWHEEL MAGNETO AND MAGNETO BASE</b> .....	5-7
EXPLODED DIAGRAM .....	5-7
REMOVAL AND INSTALLATION CHART .....	5-8
SERVICE POINTS .....	5-8
Flywheel magneto removal .....	5-8
<b>ELECTRICAL UNIT</b> .....	5-10
EXPLODED DIAGRAM .....	5-10
REMOVAL AND INSTALLATION CHART .....	5-11
<b>CONTROL UNIT</b> .....	5-12
EXPLODED DIAGRAM .....	5-12
REMOVAL AND INSTALLATION CHART .....	5-13
<b>REED VALVE</b> .....	5-14
EXPLODED DIAGRAM .....	5-14
REMOVAL AND INSTALLATION CHART .....	5-15
SERVICE POINTS .....	5-15
Reed valve inspection .....	5-15
<b>CYLINDER HEAD, THERMOSTAT AND EXHAUST COVER</b> .....	5-16
EXPLODED DIAGRAM .....	5-16
REMOVAL AND INSTALLATION CHART .....	5-17
SERVICE POINTS .....	5-17
Cylinder head inspection .....	5-17
Thermostat inspection .....	5-18

<b>CRANKCASE AND CYLINDER BODY</b> .....	5-18
<b>EXPLODED DIAGRAM</b> .....	5-19
<b>REMOVAL AND INSTALLATION CHART</b> .....	5-20
<b>SERVICE POINTS</b> .....	5-21
Cylinder body inspection .....	5-21
Piston to cylinder clearance .....	5-22
Cylinder body and crankcase installation .....	5-22
<b>CRANK SHAFT AND PISTON</b> .....	5-23
<b>EXPLODED DIAGRAM</b> .....	5-23
<b>REMOVAL AND INSTALLATION CHART</b> .....	5-24
<b>SERVICE POINTS</b> .....	5-25
Bearing removal .....	5-25
Piston inspection .....	5-25
Piston pin and small end bearing inspection .....	5-25
Piston ring inspection .....	5-26
Crankshaft inspection .....	5-27
Piston and piston ring installation .....	5-28
Crankshaft and piston installation .....	5-28



**POWER UNIT REMOVAL**  
EXPLODED DIAGRAM

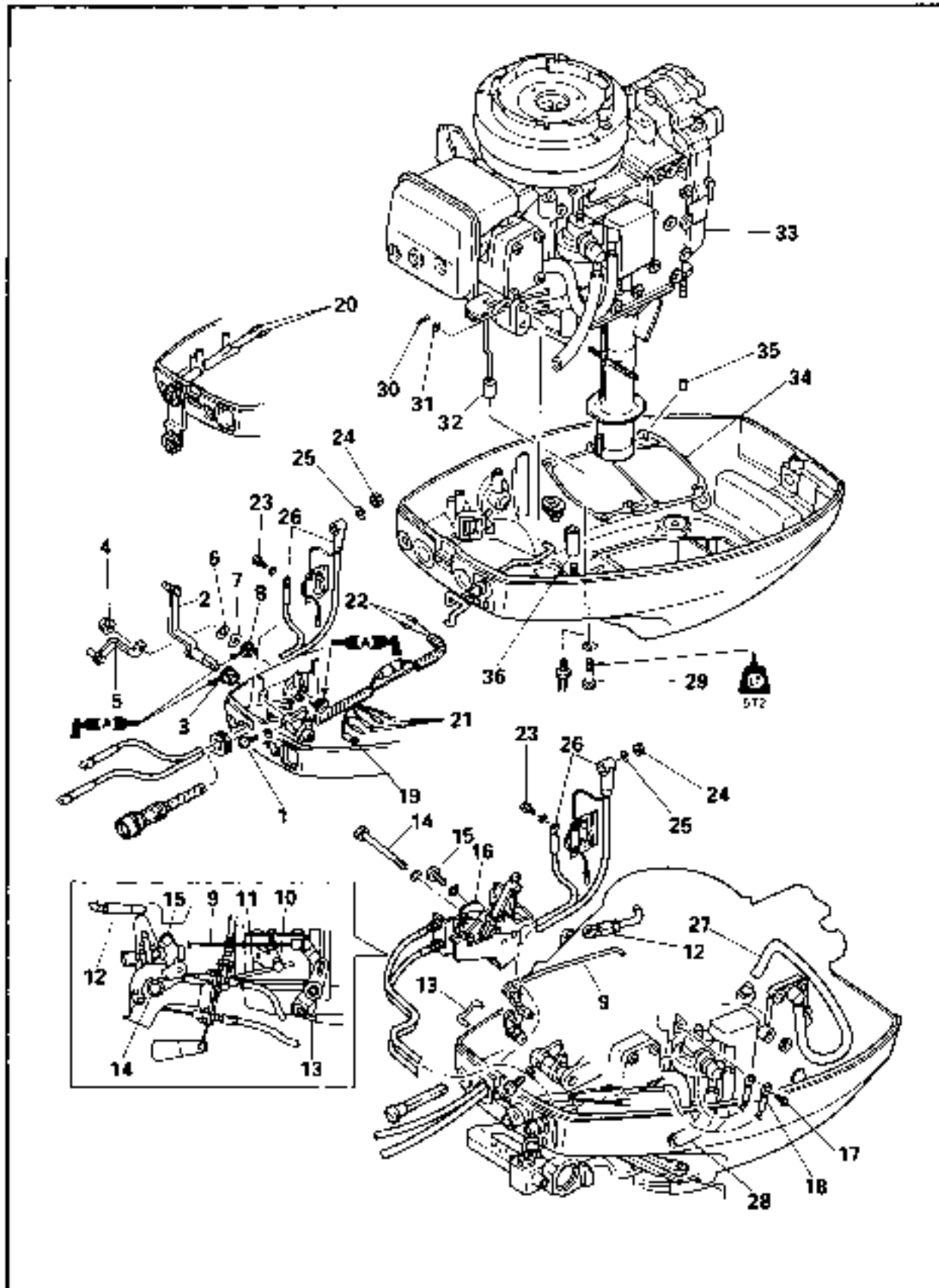



**REMOVAL AND INSTALLATION CHART**

Step	Procedure/Part name	Q'ty	Service points
	<b>POWER UNIT REMOVAL</b>		Follow the left "Step" for removal.
1	Screw (with washer)	1	for remote model
2	Shift lever link	1	
3	Bushing	1	
4	Nut	1	
5	Throttle lever link	1	
6	Plane washer	1	
7	Wave washer	1	
8	Bushing	2	
9	Choke link rod	1	
10	Screw	1	
11	Acceleration rod	1	
12	Link joint	1	
13	Choke knob rod	1	
14	Bolt (with washer)	1	
15	Bolt (with washer)	1	
16	Control pulley bracket assembly	1	
17	Bolt (with washer)	1	
18	Engine stop switch lead	2	- Except for remote model
19	Wire harness ground lead	1	- for remote model
20	2P connector lead	2	- for 2P connector model
21	Wire harness rectifier lead	4	for remote model
22	Wire harness starter relay lead	2	
23	Bolt (with washer)	1	Electrical starter model.
24	Nut	1	
25	Spring washer	1	
26	Battery cable	1	
27	Pilot water hose	1	
28	Fuel hose	1	
29	Bolt (with washer)	6	8 x 30 mm
30	Clip	1	
31	Plane washer	1	
32	Shift lever rod	1	
33	Engine unit	1	
34	Upper case gasket	1	
35	Dowel pin	2	
36	Collar	1	
			Reverse the removal steps for installation.



RECOIL STARTER  
EXPLODED DIAGRAM

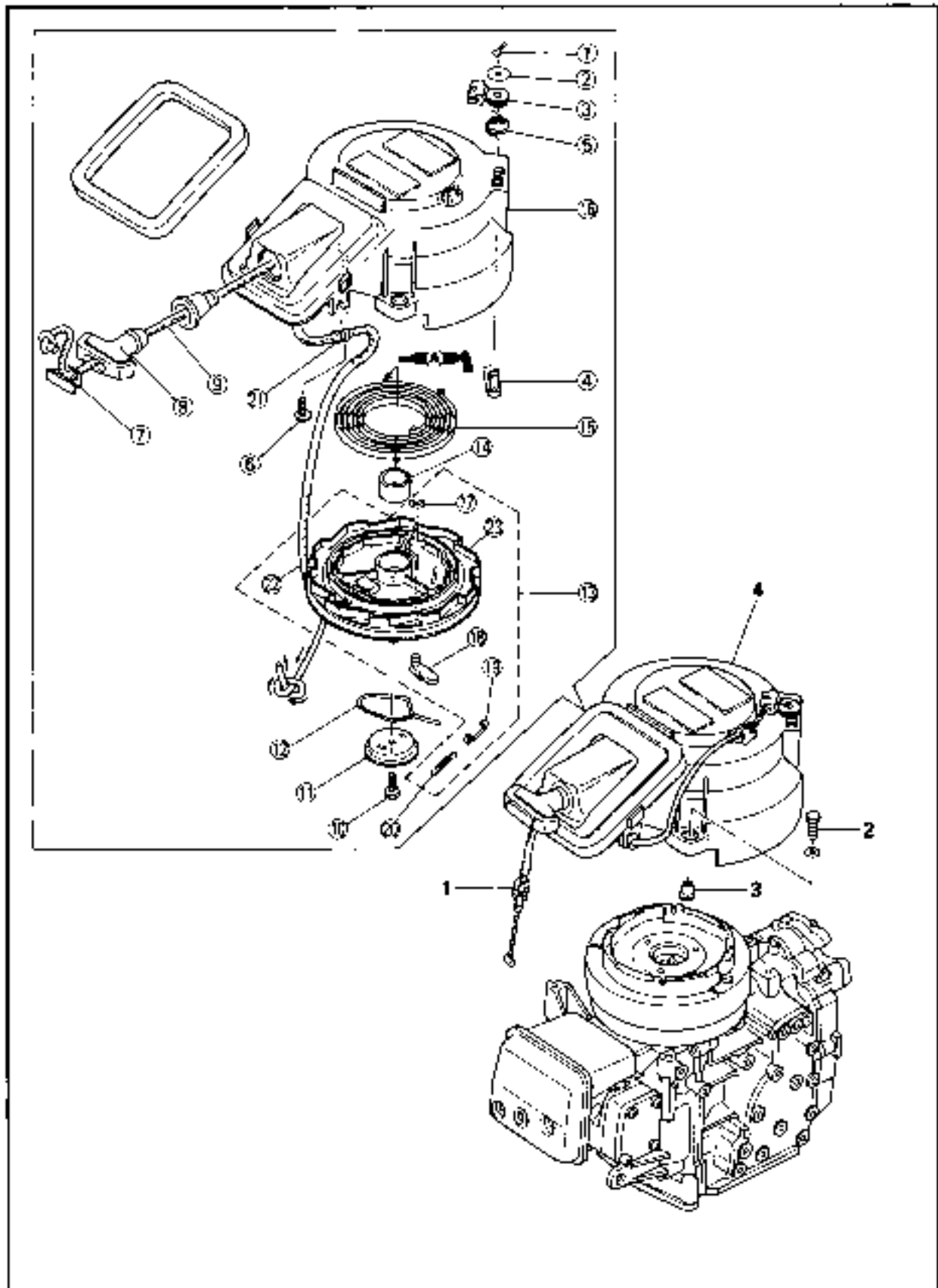



**REMOVAL AND INSTALLATION CHART**

Step	Procedure/Part name	Qty	Service points
<b>RECOIL STARTER REMOVAL</b>			
1	Start in-gear protection wire	1	Follow the left "Step" for removal.
2	Bolt (with washer)	3	for start in-gear protection model
3	Collar	3	6 x 20 mm
4	Recoil starter assembly	1	
<b>RECOIL STARTER DISASSEMBLY</b>			
①	Cotter pin	1	for start-in-gear protection model
②	Plane washer	1	
③	Reel stopper	1	
④	Stopper arm	1	
⑤	Spring	1	
⑥	Screw	1	
⑦	Cover	1	
⑧	Starter handle	1	
⑨	Starter rope	1	
⑩	Bolt (with washer)	1	
⑪	Drive plate	1	
⑫	Drive pawl spring	1	
⑬	Sheave drum assembly	1	<b>NOTE:</b>
			• Position the inner end of the spiral spring on the retainer post of the sheave drum.
			• Wind up the spring 2-1/2 turns counter-clockwise with the starter rope.
⑭	Bushing	1	
⑮	Spiral spring	1	
⑯	Starter case	1	
<b>SHEAVE DRUM DISASSEMBLY</b>			
⑰	Circlip	1	
⑱	Drive pawl	1	
⑲	Spring	1	
⑳	Return spring	1	
㉑	Rope guide	1	
㉒	Starter rope	1	<b>NOTE:</b>
			• Wind the rope 2 turns around the sheave drum.
㉓	Sheave drum	1	
			Reverse the removal steps for installation.

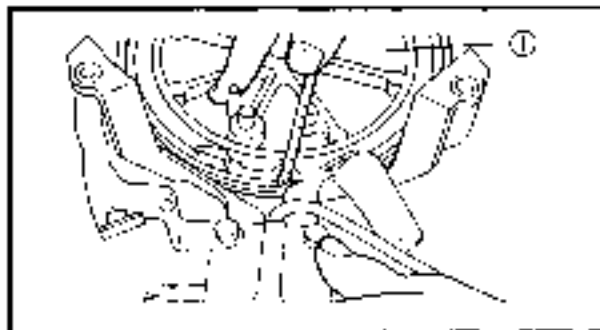

## SERVICE POINTS

### Sheave drum removal

1. Turn:
  - Sheave drum ①  
Turn the sheave drum clockwise until the spiral spring is free.

#### NOTE:

- Turn the sheave drum so that the cutaway on the outer surface of the sheave drum faces toward the starter handle.
- Pass the starter rope through the cut.

2. Remove:
  - Sheave drum

### **▲WARNING**

When removing the sheave drum, be sure to turn the sheave drum upside down to prevent the spiral spring from popping up at you.

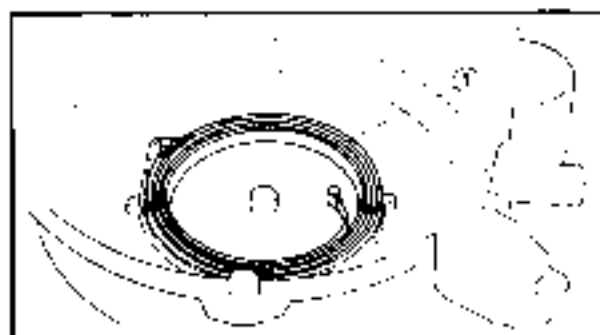

### Spiral spring removal

1. Remove:
  - Spiral spring ①

### **▲WARNING**

Be careful so that the spiral spring does not pop out when removing it. Remove it by allowing it out one turn of the winding each time.

### Starter stopping plunger inspection

1. Inspect
  - Starter stopping plunger  
Crack/Wear/Damage → Replace.

### Drive pawl and spring inspection

1. Inspect:
  - Drive pawl  
Crack/Wear/Damage → Replace.
  - Drive pawl spring  
Broken/Bent/Damage → Replace.

### Bushing inspection

1. Inspect:
  - Bushing  
Crack/Damage → Replace.

**Sheave drum inspection**

1. Inspect.
  - Sheave drum  
Crack/Damage → Replace.

**Spiral spring inspection**

1. Inspect:
  - Spiral spring  
Broken/Bent/Damage → Replace.

**Starter rope inspection**

1. Inspect.
  - Starter rope  
Fray/Wear/Damage → Replace.

**NOTE:**

When replacing the rope, cut it to the specified length and burn the rope end so that it will not travel.



**Starter rope length:**  
1,800 mm (70.9 in)

**Recoil starter checking**

1. Check:
  - Starter operation  
Rough operation → Repair.





FLYWHEEL MAGNETO AND MAGNETO BASE  
EXPLODED DIAGRAM

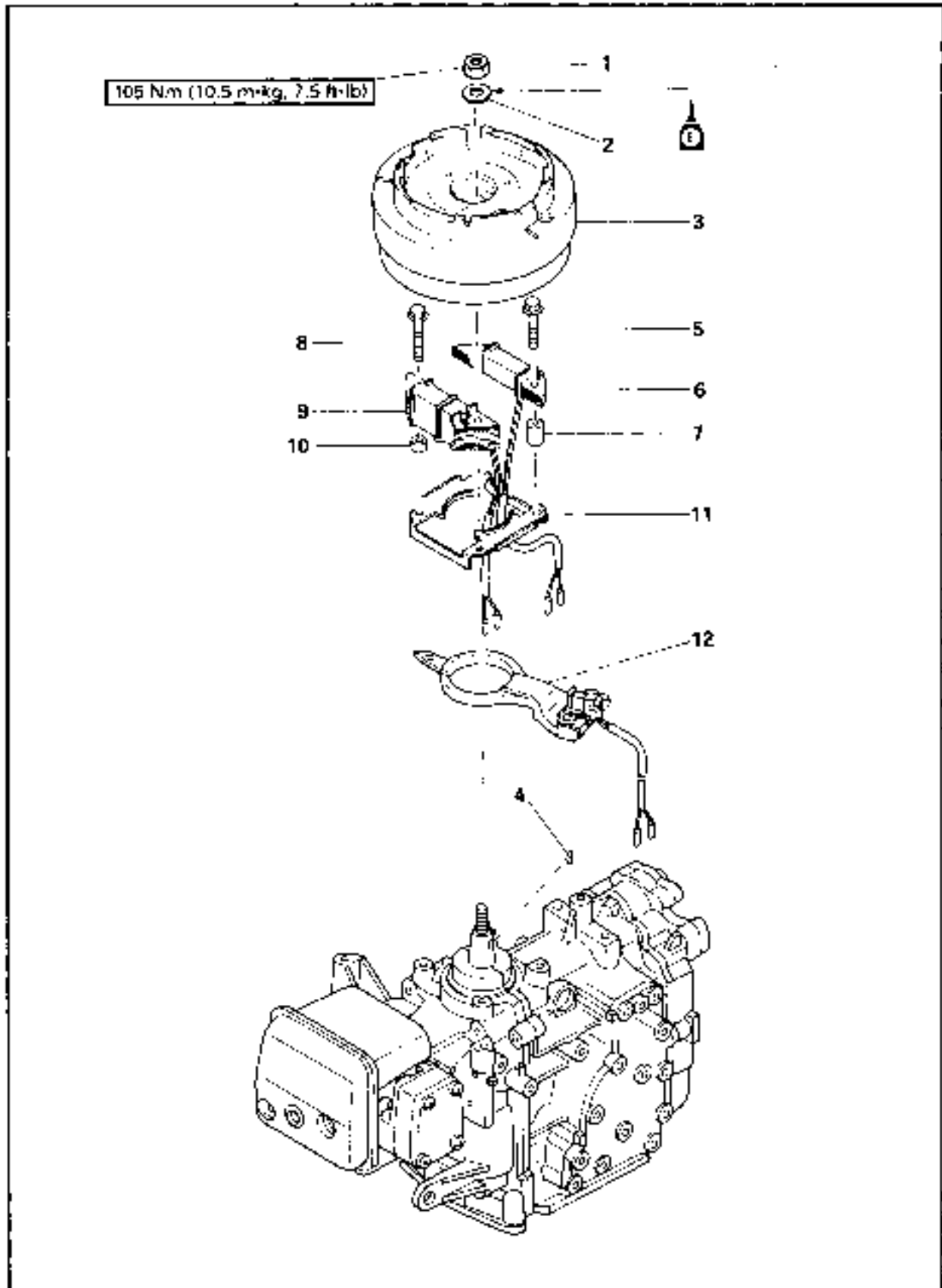



REMOVAL AND INSTALLATION CHART

Step	Procedure/Part name	Q'ty	Service points
	<b>FLYWHEEL MAGNETO AND MAGNETO BASE REMOVAL</b> Recoil starter assembly		Follow the left "Step" for removal.  Refer to the "RECOIL STARTER" section.
1	Nut	1	
2	Plane washer	1	
3	Flywheel	1	
4	Woodruff key	1	
5	Bolt (with washer)	2	
6	Charge coil	1	
7	Collar	2	
8	Bolt (with washer)	2	
9	Lighting coil	1	
10	Collar	2	
11	Magneto base plate	1	
12	Pulser coil assembly	1	
			Reverse the removal steps for installation.

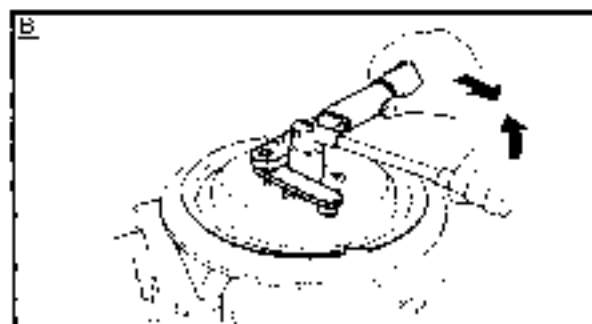
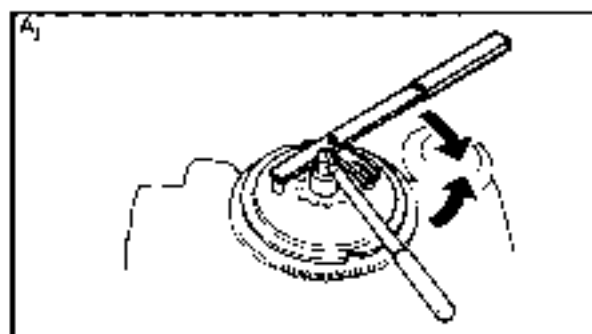

**SERVICE POINTS**

**Flywheel magneto removal**

1. Remove and install:
  - Flywheel nut



**Flywheel holder:**

**YB-06139/90890-06522**

A For USA and CANADA

B Except for USA and CANADA

**CAUTION:**

The major load should be carried in the direction of the arrows. If not, the holder may easily slip off.

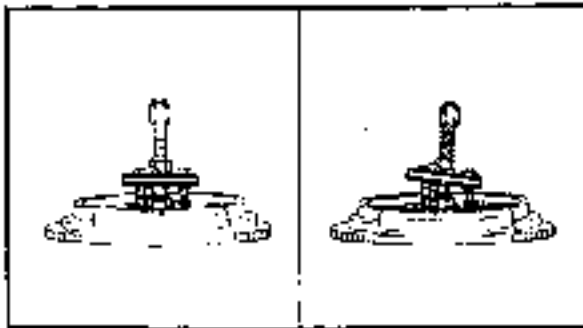
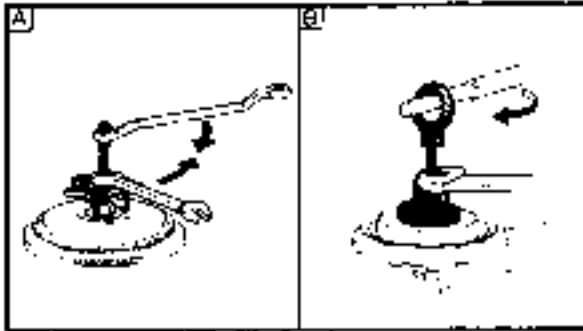

## 2. Remove:

- ♦ Flywheel magneto



Flywheel puller:

YB-08117/90890-06521

|A| For USA and CANADA

|B| Except for USA and CANADA

**CAUTION:**

- ♦ Keep the nut side flush with the crankshaft end until the flywheel comes off the tapered portion of the crankshaft.
- ♦ To prevent damage to the engine or tools, screw in the flywheel magneto-puller set-bolts evenly and completely so that the puller plate is parallel to the flywheel.



ELECTRICAL UNIT  
EXPLODED DIAGRAM

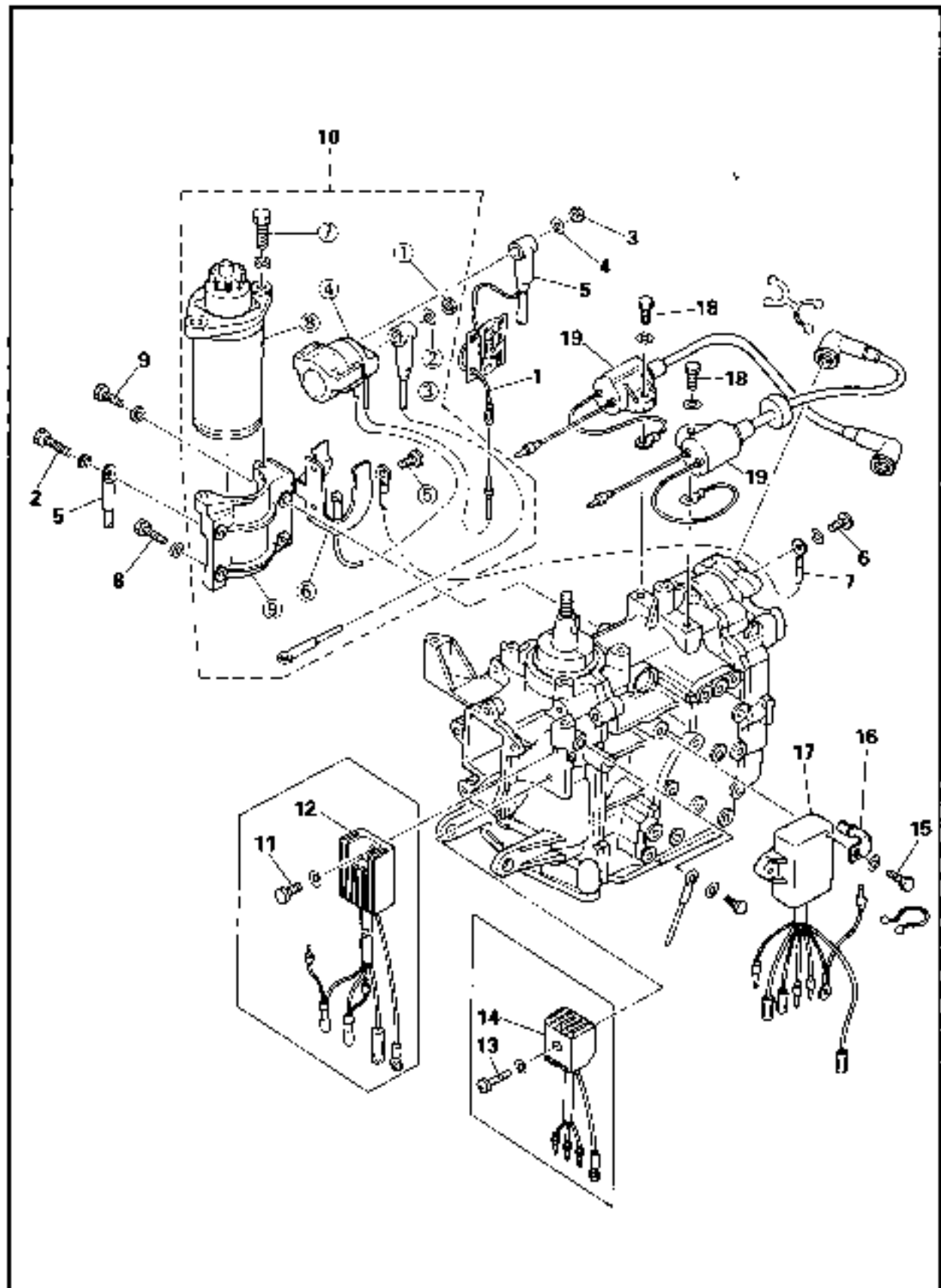



**REMOVAL AND INSTALLATION CHART**

Step	Procedure/Part name	Qty	Service points
<b>ELECTRICAL UNIT REMOVAL</b>			Follow the left "Step" for removal.
1	Starter relay lead	2	for electrical starter model
2	Bolt (with washer)	1	6 x 30 mm
3	Nut	1	
4	Spring washer	1	-
5	Battery cable	1	-
6	Bolt (with washer)	1	-
7	Cylinder head ground lead	1	-
8	Bolt (with washer)	1	8 x 25 mm
9	Bolt (with washer)	2	8 x 20 mm
10	Electrical unit	1	
11	Bolt (with washer)	1	for 2P connector model: 6 x 16 mm
12	Rectifier regulator	1	
13	Screw (with washer)	1	for electrical starter model
14	Rectifier	1	
15	Bolt (with washer)	2	8 x 20 mm
16	Clamp	1	
17	CDI unit	1	
18	Bolt (with washer)	2	6 x 18 mm
19	Ignition coil	2	
<b>ELECTRICAL UNIT DISASSEMBLY</b>			
①	Nut	1	
②	Spring washer	1	
③	Lead wire	1	
④	Starter relay	1	
⑤	Bolt (with washer)	2	6 x 14 mm
⑥	Starter relay bracket	1	
⑦	Bolt (with washer)	2	
⑧	Starter motor	1	
⑨	Starter motor bracket	1	
			Reverse the removal steps for installation.



**CONTROL UNIT  
EXPLODED DIAGRAM**

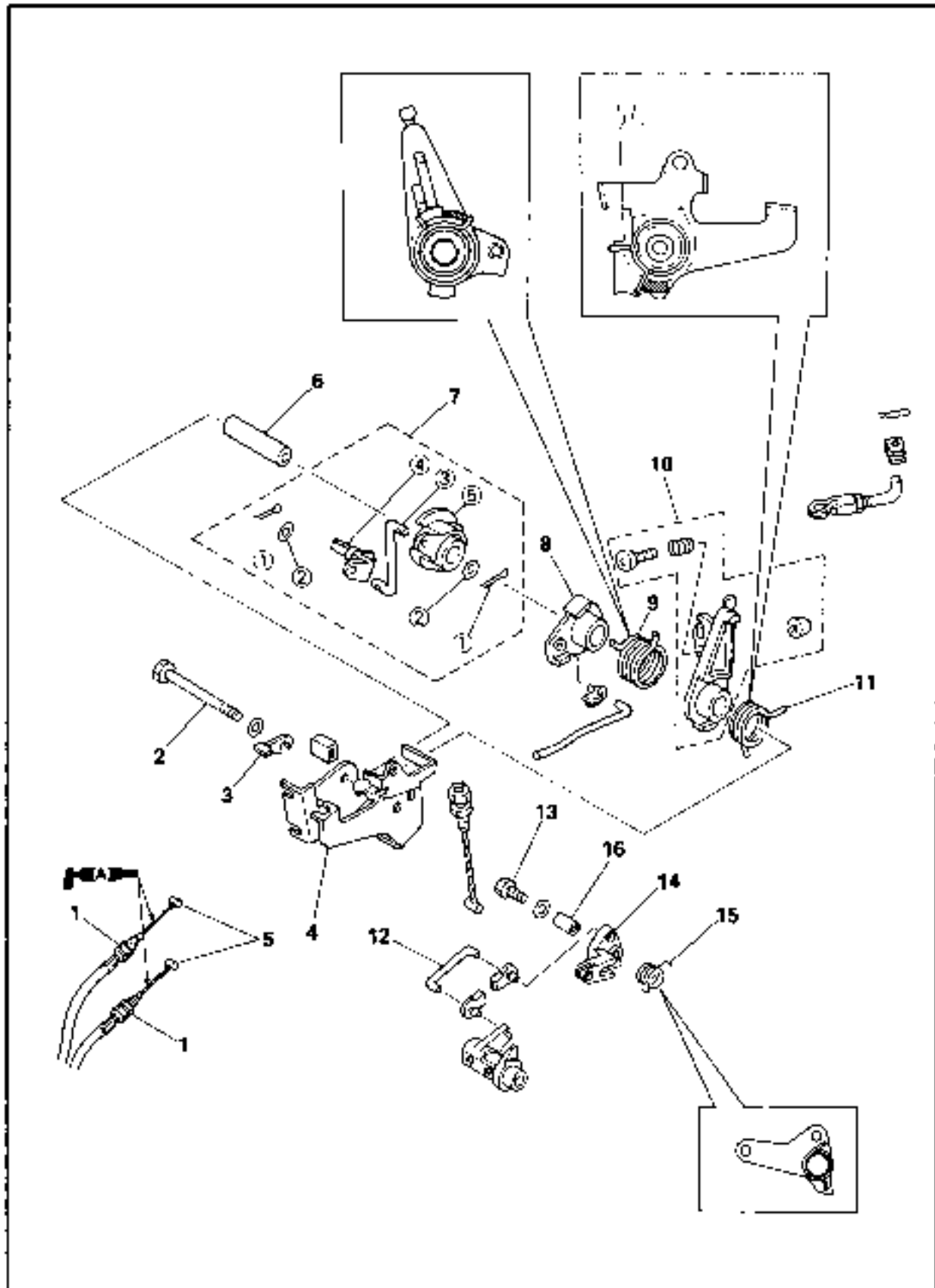



**REMOVAL AND INSTALLATION CHART**

Step	Procedure/Part name	Q'ty	Service points
	<b>CONTROL UNIT DISASSEMBLY</b>		
	Control pulley bracket assembly		Follow the left "Step" for removal Refer to the "POWER UNIT REMOVAL" section.
1	Throttle cable lock nut	2	
2	Bolt (with washer)	1	
3	Plate	1	for over revolution limit model
4	Control pulley bracket	1	
5	Throttle cable	2	
6	Collar	1	
7	Control pulley assembly	1	
8	Accelerator lever	1	
9	Accelerator lever spring	1	
10	Magneto control lever	1	
11	Magneto control lever spring	1	
12	Start-in-gear lever rod	1	
13	Bolt (with washer)	1	6 x 20mm
14	Start-in-gear lever	1	
15	Start-in-gear lever spring	1	
16	Collar	1	
	<b>CONTROL PULLEY DISASSEMBLY</b>		
①	Cotter pin	2	
②	Plane washer	2	
③	Control pulley rod	1	
④	Control pulley lever	1	
⑤	Control pulley	1	
			Reverse the removal steps for installation.



**REED VALVE  
EXPLODED DIAGRAM**

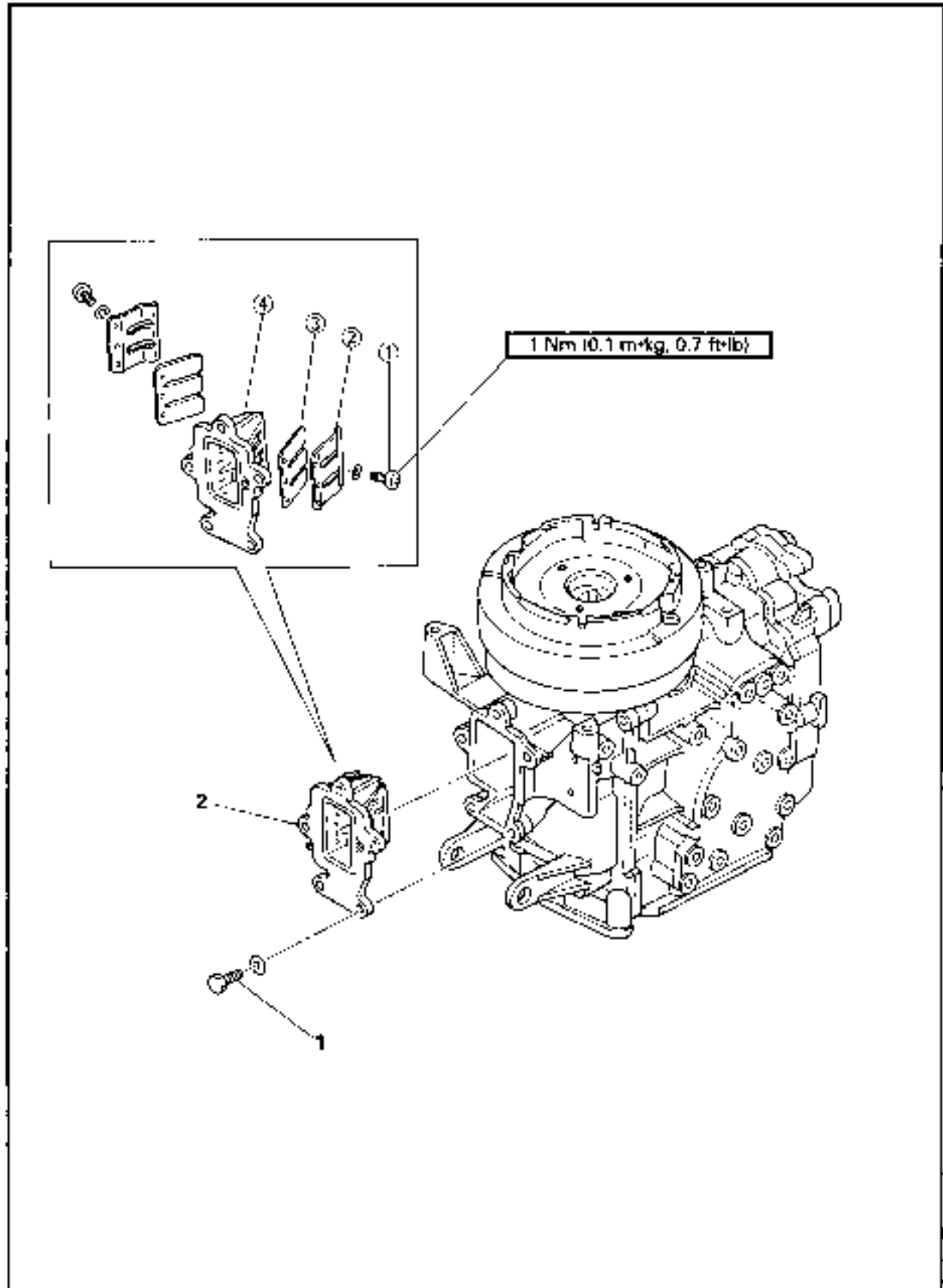





**REMOVAL AND INSTALLATION CHART**

Step	Procedure/Part name	Qty	Service points
<b>REED VALVE REMOVAL</b>			Follow the left "Step" for removal.
	Carburetor assembly		Refer to the "CARBURETOR REMOVAL" section in chapter 4.
1	Bolt (with washer)	3	6 x 20 mm
2	Reed valve assembly	1	
<b>REED VALVE DISASSEMBLY</b>			
①	Screw (with washer)	6	
②	Valve stopper	2	
③	Reed valve	2	
④	Reed valve body	1	
			Reverse the removal steps for installation.

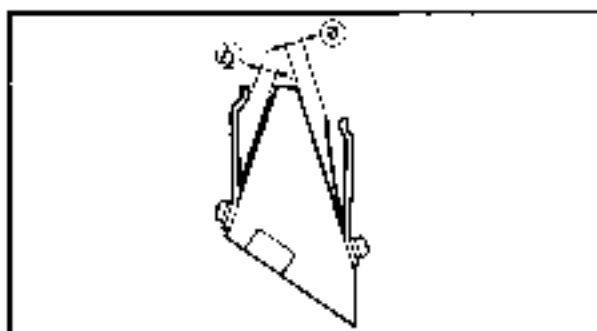

**SERVICE POINTS**

**Reed valve inspection**

1. Inspect:
  - Reed valve  
Crack/Damage → Replace.
2. Measure:
  - Valve bending .a'  
Out of specification → Replace.



**Valve bending limit:**  
0.2 mm (0.01 in)

- 3 Measure:
  - Valve stopper height .b  
Out of specification → Replace.



**Valve stopper height:**  
9.9:  
except for Europe  
0.7 ± 0.1 mm (0.03 ± 0.004 in)  
for Europe  
1.3 ± 0.1 mm (0.05 ± 0.004 in)  
15:  
6.0 ± 0.1 mm (0.24 ± 0.004 in)



CYLINDER HEAD, THERMOSTAT AND EXHAUST COVER  
EXPLODED DIAGRAM

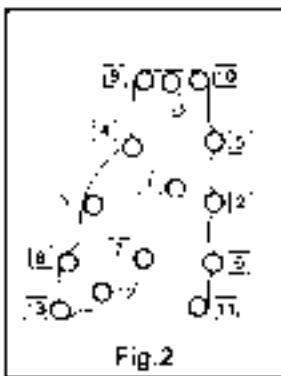
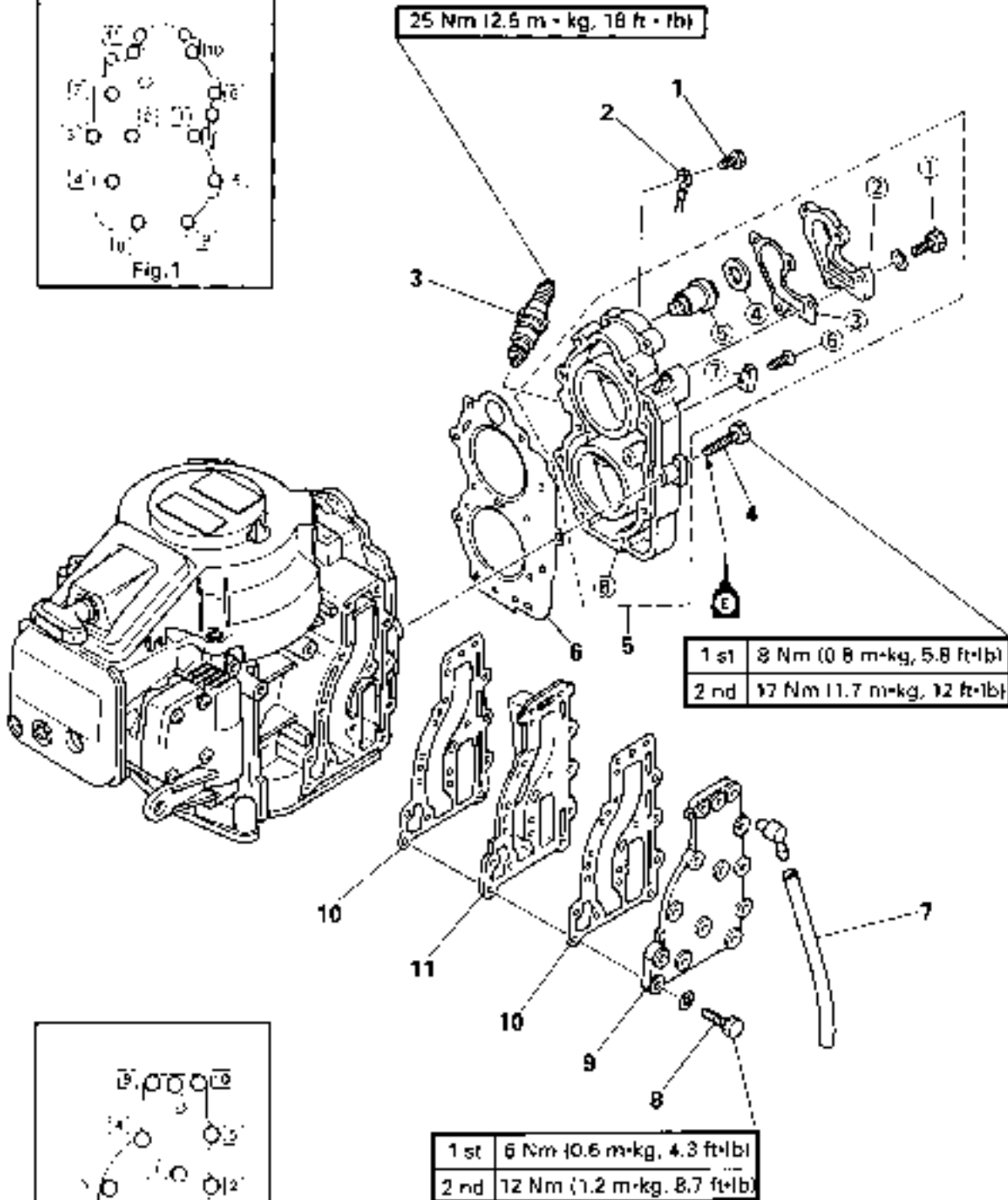
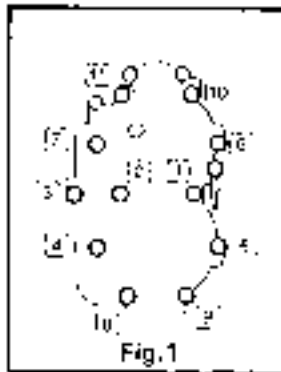



**REMOVAL AND INSTALLATION CHART**

Step	Procedure/Part name	Q'ty	Service points
	<b>CYLINDER HEAD, THERMOSTAT AND EXHAUST COVER REMOVAL</b>		Follow the left "Step" for removal.
1	Bolt (with washer)	1	6 x 12 mm
2	Cylinder head ground lead	1	
3	Spark plug	2	
4	Flange bolt	11	<b>NOTE:</b> _____
5	Cylinder head assembly	1	Tighten the bolts in sequence and in two steps of torque. (Refer to fig. 1)
6	Cylinder head gasket	1	_____
7	Pilot water hose	1	
8	Bolt (with washer)	13	<b>NOTE:</b> _____
9	Exhaust outer cover	1	Tighten the bolts in sequence and in two steps of torque. (Refer to fig. 2)
10	Exhaust cover gasket	2	_____
11	Exhaust inner cover	1	
	<b>CYLINDER HEAD DISASSEMBLY</b>		
①	Bolt (with washer)	4	6 x 20 mm
②	Thermostat cover	1	
③	Thermostat cover gasket	1	
④	Plane washer	1	
⑤	Thermostat	1	
⑥	Screw	1	
⑦	Anode	1	
⑧	Cylinder head	1	
			Reverse the removal steps for installation.

**SERVICE POINTS**

**Cylinder head inspection**

1. Inspect:
  - Water jacket  
Material deposit/Corrosion → Clean.
  - Cylinder inner surface  
Score marks → Clean.  
Use #600 - 800 grit wet sandpaper.

**CAUTION:** \_\_\_\_\_

Do not scratch the fitting surfaces of the cylinder and cylinder cover.

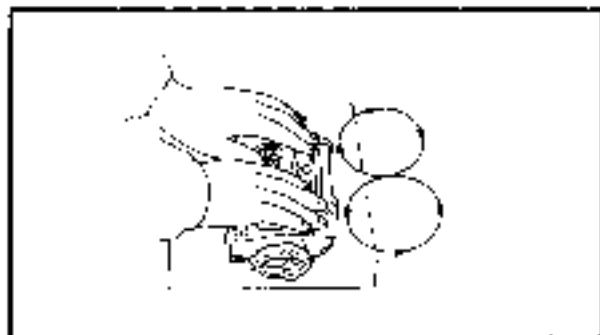

**2. Measure:**

- Cylinder head warpage  
Use a straightedge and thickness gauge.  
Out of specification → Resurface or replace.



**Warpage limit:**  
0.1 mm (0.004 in)

**Resurfacing steps:**

- Place a 400 - 600 grit wet sandpaper on the surface plate.
- Resurface the head using a figure-eight sanding pattern.

**Thermostat inspection**

**1. Inspect:**

- Thermostat  
Stick/Damage → Replace.

**2. Measure:**

- Valve opening temperature
- Valve lift  
Out of specification → Replace.

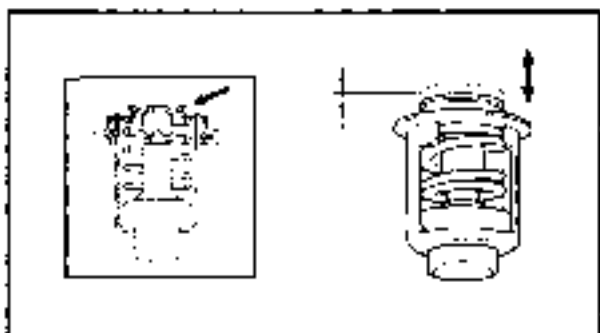

Water temperature	Valve lift
Below 48 - 52 °C (118 - 126 °F)	0 mm (0 in)
Above 60 °C (140 °F)	Min. 3 mm (0.12 in)

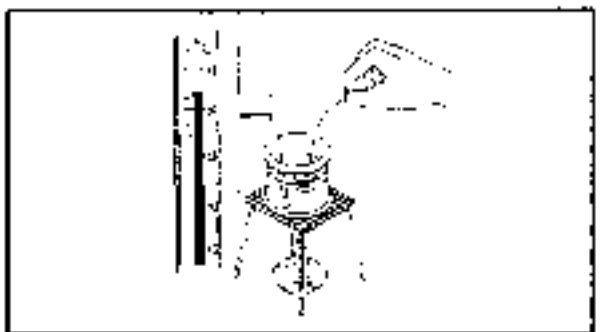

**Measuring steps:**

- Suspend thermostat in a vessel.
- Place reliable thermometer in a water.
- Heat water slowly.
- Observe thermometer, while stirring water continually.



CRANKCASE AND CYLINDER BODY  
EXPLODED DIAGRAM

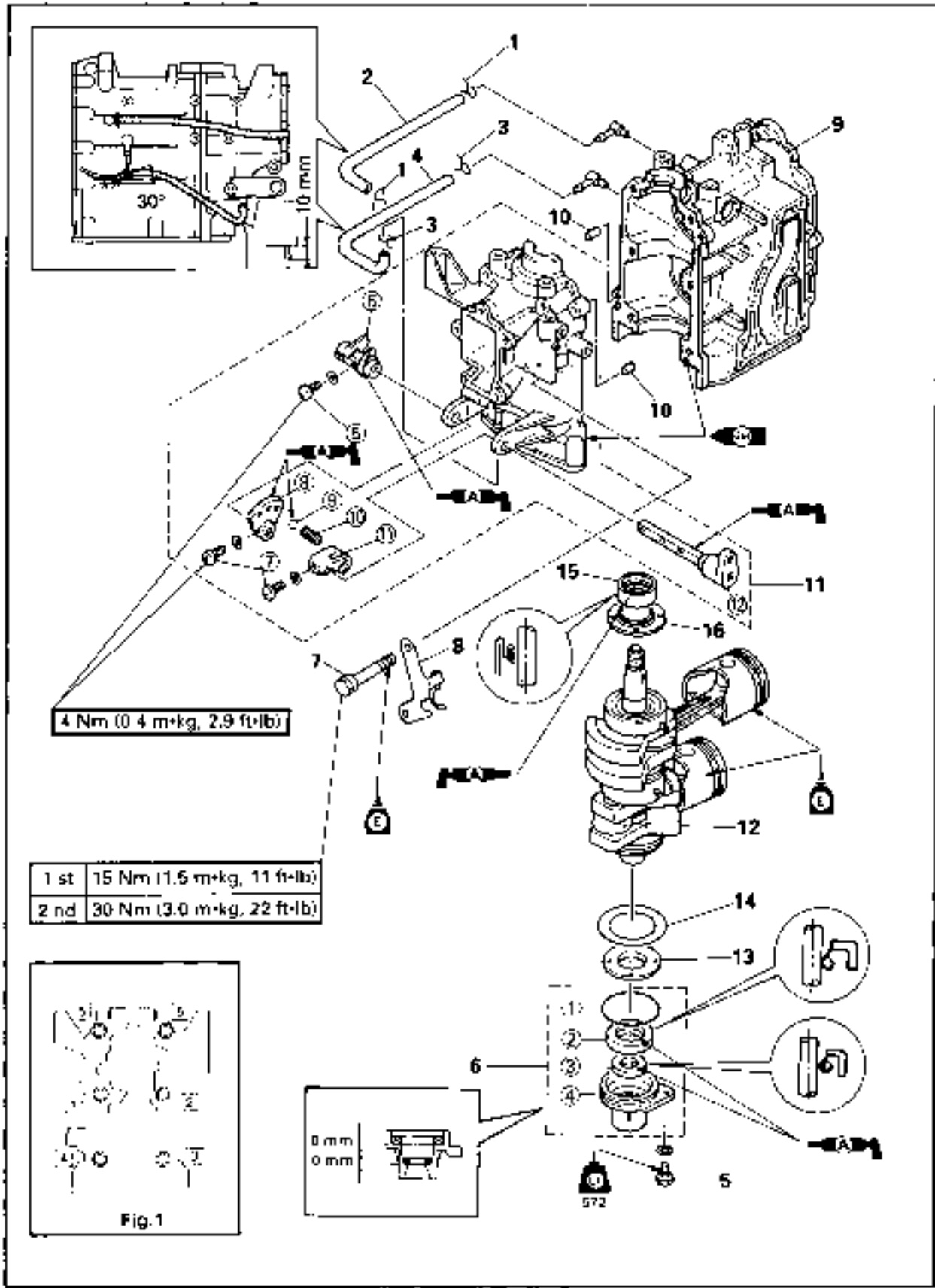



REMOVAL AND INSTALLATION CHART

Step	Procedures/Part name	Qty	Service points
	<b>CRANK CASE AND CYLINDER BODY REMOVAL</b>		Follow the left "Step" for removal.
1	Clip	2	
2	Hose	1	
3	Clip	2	
4	Hose	1	
5	Bolt (with washer)	1	6 x 16 mm
6	Oil seal housing	1	
7	Bolt (with washer)	6	<b>NOTE:</b> Tighten the bolts in sequence and in two steps of torque. (Refer to fig.1)
8	Neutral switch bracket	1	for electrical starter model
9	Cylinder body	1	
10	Dowel pin	2	
11	Crank case assembly	1	
12	Crank shaft assembly	1	
13	Plate	1	
14	Plane washer	1	
15	Oil seal	1	
16	Plate	1	
	<b>OIL SEAL HOUSING DISASSEMBLY</b>		
(1)	O-ring	1	
(2)	Oil seal	1	
(3)	Oil seal	1	
(4)	Oil seal housing	1	
	<b>CRANK CASE DISASSEMBLY</b>		
(5)	Screw (with washer)	1	5 x 12 mm
(6)	Shift lever bushing	1	
(7)	Screw (with washer)	2	5 x 12 mm
(8)	Cam plate	1	
(9)	Ball	1	
(10)	Spring	1	
(11)	Shaft rod lever	1	
(12)	Shift arm shaft	1	
			Reverse the removal steps for installation.



**SERVICE POINTS**

**Cylinder body inspection**

1. Inspect:
  - Water jacket  
Material deposit/Corrosion → Clean.
  - Cylinder inner surface  
Score marks → Clean.  
Use #600 - 800 grit wet sandpaper.

**NOTE:**

Do not scratch the fitting surfaces of the crank case and cylinder head.

2. Inspect:
  - Exhaust wall  
Crack/Damage → Replace.  
Carbon deposit → Clean.  
Use a round scraper

**NOTE:**

Do not scratch the fitting surfaces of the cylinder and exhaust cover.

3. Measure:
  - Cylinder bore "D"  
Use cylinder gauge  
Out of specification → Rebore or replace.

**NOTE:**

Measure the cylinder bore "D" in parallel. Then, find the average of the measurement.

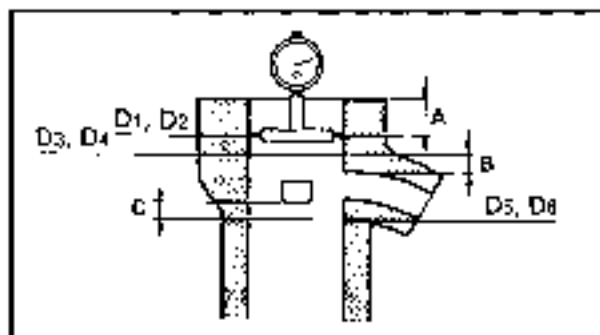
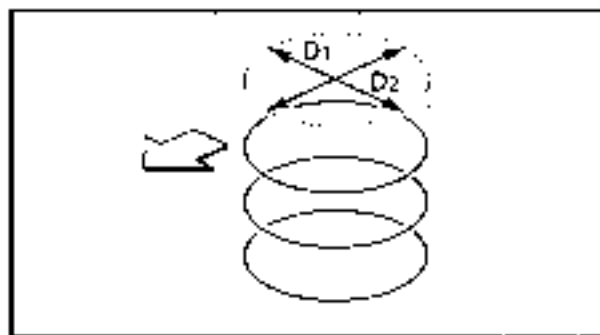
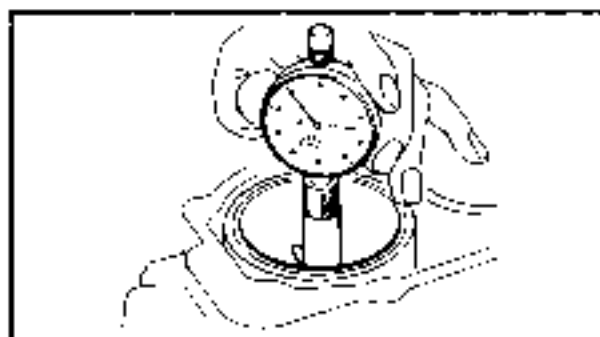

	Standard	Wear limit
Cylinder bore "D"	56.00 - 56.02 mm (2.205 - 2.208 in)	56.1 mm (2.21 in)
Taper limit T:	-	0.08 mm (0.003 in)
Out of round limit	-	0.05 mm (0.002 in)
D = Maximum Dia. (D1 - D6)		
T = (maximum D1 or D2) - (minimum D5 or D6)		

- A: 10 mm (0.4 in) below the cylinder top
- B: 5 mm (0.2 in) above the exhaust port
- C: 5 mm (0.2 in) below the scavenging port

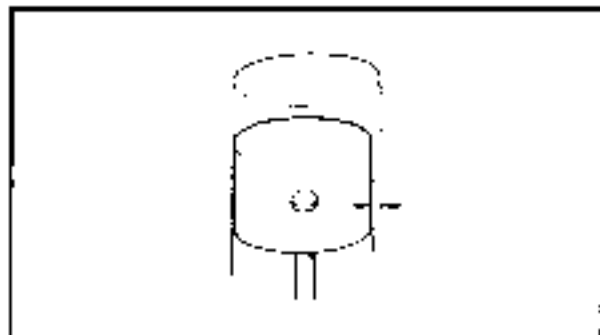

**Piston to cylinder clearance**

1. Calculate:
  - Piston clearance
 Out of specification → Replace piston and piston ring and/or cylinder.

<b>Piston clearance</b>	=	<b>Cylinder bore</b>	-	<b>Piston diameter</b>
-------------------------	---	----------------------	---	------------------------

	<p><b>Piston clearance:</b>                  0.035 - 0.040 mm                  (0.0014 - 0.0016 in)</p>
--	---

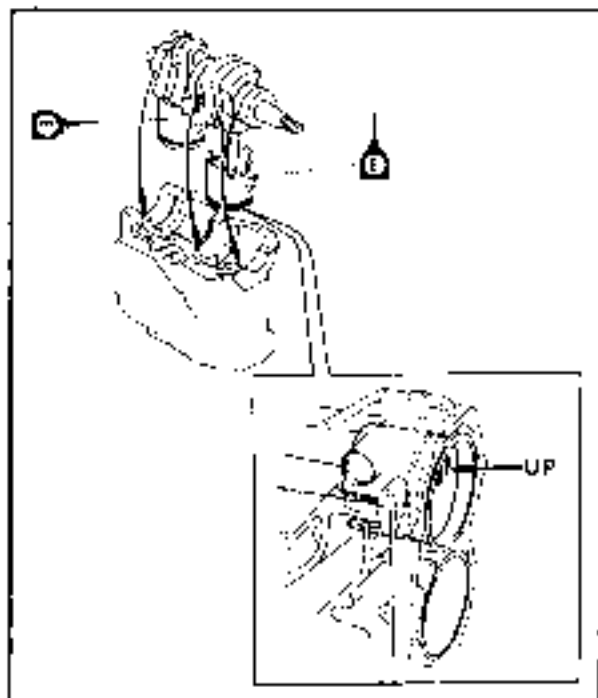

**Cylinder body and crankcase installation**

1. Install:
  - Cylinder body
  - Crankshaft and piston

**NOTE:**

- Align the piston ring end gaps with the respective locating pins.
- Fit the bearing locating pins in the cylinder body

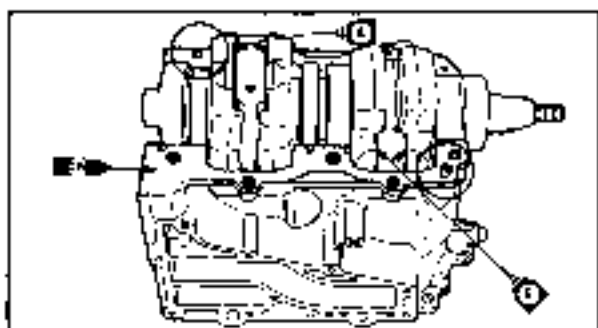

2. Apply:
  - Gasket maker
 Onto the connecting surfaces of the crankcase and cylinder body.

**NOTE:**

- Clean the connecting surfaces of the crankcase and cylinder body before applying the Gasket maker.
- Gasket maker should be so applied that it does not overflow the contacting surface.





CRANK SHAFT AND PISTON  
EXPLODED DIAGRAM

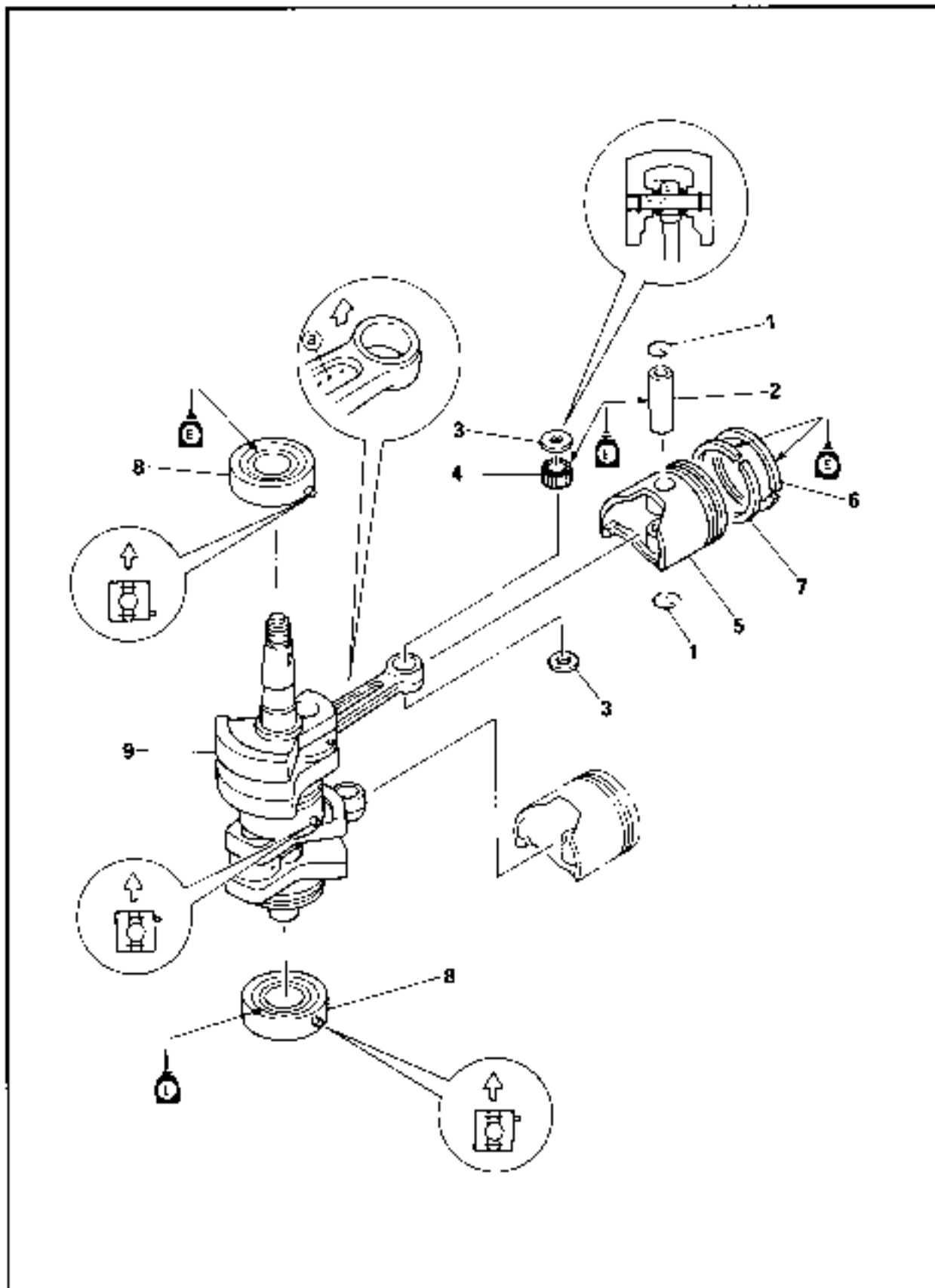



REMOVAL AND INSTALLATION CHART

Step	Procedure/Part name	Q'ty	Service points
	<b>CRANK SHAFT AND PISTON DISASSEMBLY</b>		Follow the left "Step" for removal.
	Crank shaft assembly		Refer to the "CRANKCASE AND CYLINDER BODY" section.
1	Piston pin clip	4	<b>NOTE:</b> _____ Take care not to damage piston pin hole edge.
			<b>CAUTION:</b> _____ Always use the new clip.
2	Piston pin	2	<b>NOTE:</b> _____ When the piston pins, pistons, and small and needle bearings are reused, they should be marked with No. 1 and 2 so that they are not confused.
3	Piston pin washer	4	<b>CAUTION:</b> _____ The washer should be placed with their convex sides facing the piston.
4	Small end bearing needle	50	<b>CAUTION:</b> _____ Do not a mixture of new and used bearing needles in the same small end.
5	Piston	2	<b>NOTE:</b> _____ Mold mark  faces in the same direction as the "UP" mark on the piston.
6	Top piston ring	2	<b>NOTE:</b> _____ Remove the piston ring from the piston by opening the ring to the least possible width.
7	2nd piston ring	2	
8	Bearing	2	
9	Crank shaft	1	
			Reverse the removal steps for installation.

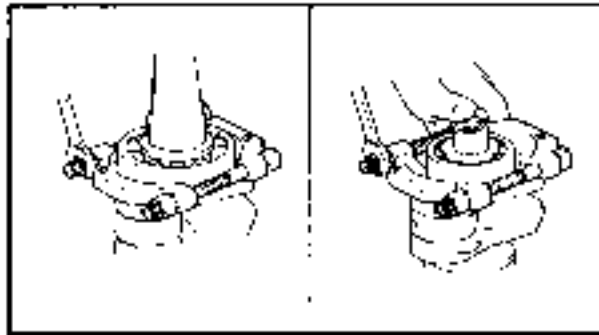

**SERVICE POINTS**

**Bearing removal**

1. Remove:
  - Bearing

**NOTE:**

Hold the bearing with the bearing separator, and forth out the crankshaft with a press.



**Bearing separator:**

YB-06219/90890-06534

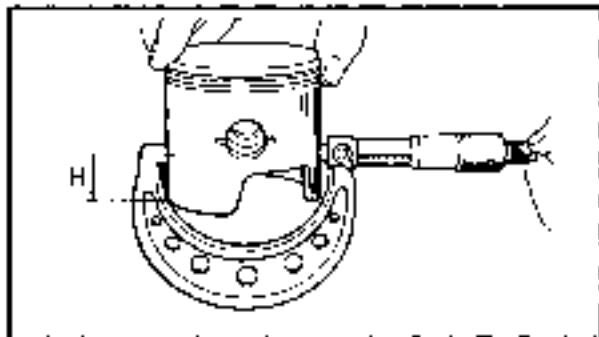

**Piston inspection**

1. Measure:
  - Piston diameter
 Use a micrometer.  
 Out of specification → Replace.



	Measuring point "H"	Piston diameter
<b>Standard</b>	10 mm (0.4 in)	55.940 - 55.985 mm 2.2024 - 2.2041 in



**Over size piston diameter:**

- 1\*: 56.25 mm (2.215 in)
- 2: 56.50 mm (2.224 in)

\*: Except for U.S.A.

2. Measure:
  - Piston pin boss inside diameter
 Use a micrometer.  
 Out of specification → Replace.



**Piston pin boss inside diameter:**

14.004 - 14.015 mm  
(0.5513 - 0.5518 in)

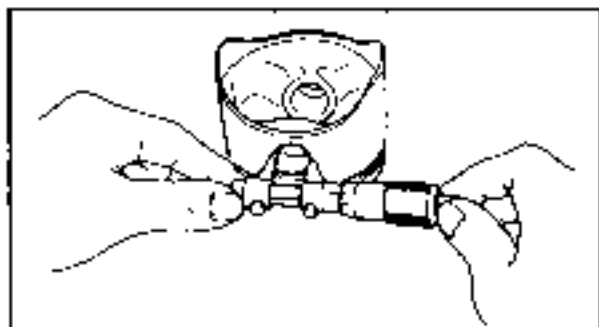

**Piston pin and small end bearing inspection**

1. Inspect:
  - Piston pin
  - Small end bearing
 Signs of heat discoloration → Replace  
 Scratch/Damage → Replace.

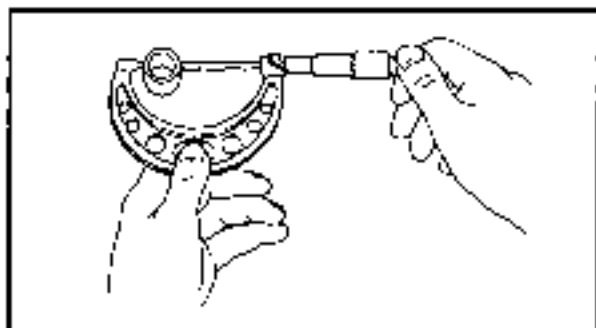

## 2. Measure:

- Piston pin diameter  
Use a micrometer.  
Out of specification → Replace.

**Piston pin diameter:**

13.996 ~ 14.000 mm  
(0.5510 ~ 0.5512 in)

## 3. Check:

- Free play (when the piston pin is inserted in the piston.)  
There should be no noticeable for the play.  
Free play exists → Replace the pin and/or piston.

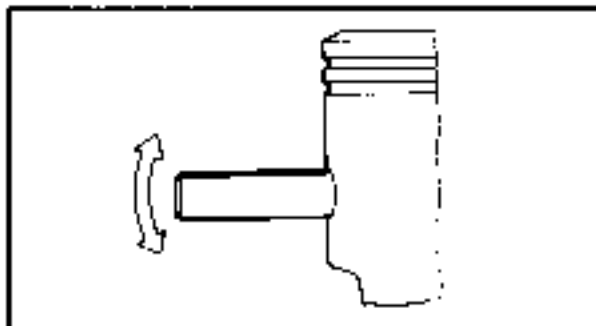
**Piston ring inspection**

## 1. Inspect:

- Piston ring  
Breakage/Damage → Replace.

## 2. Measure:

- End gap  
Use a feeler gauge.  
Out of specification → Replace.

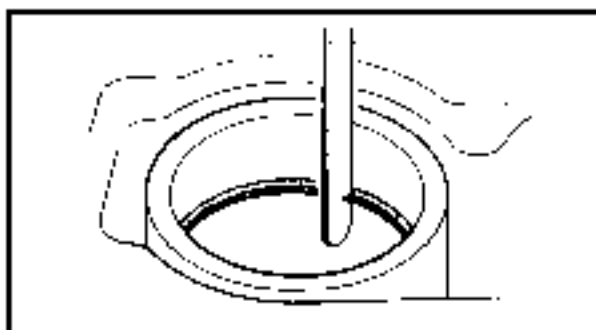
**End gap:**

Top: 0.15 ~ 0.35 mm  
(0.006 ~ 0.014 in)

2nd: 0.15 ~ 0.35 mm  
(0.006 ~ 0.014 in)

**End gap limit:**

Top: 0.55 mm (0.022 in)

2nd: 0.55 mm (0.022 in)

**Measuring point**

20 mm (0.8 in)

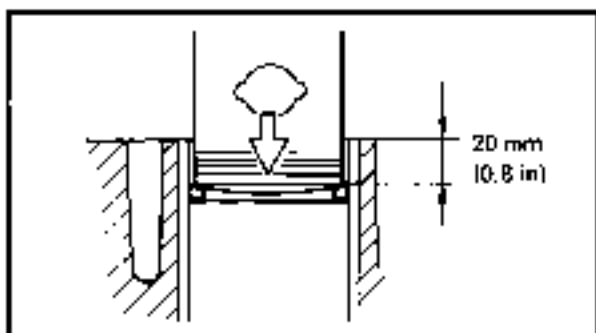
**NOTE:**

Install the piston ring into the cylinder. Push the ring with the piston crown.

## 3. Measure:

- Side clearance  
Use a thickness gauge.  
Out of specification → Replace piston and/or ring.

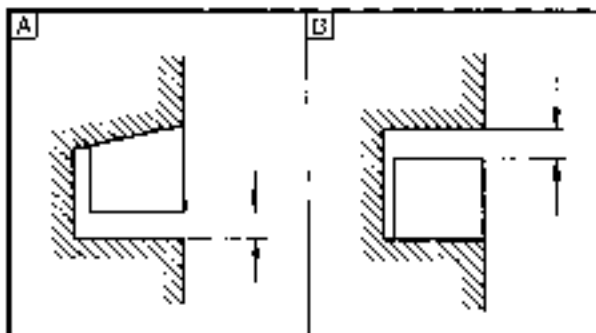
**Side clearance:**

Top (A): 0.02 ~ 0.06 mm  
(0.001 ~ 0.002 in)

2nd (B): 0.04 ~ 0.08 mm  
(0.002 ~ 0.003 in)

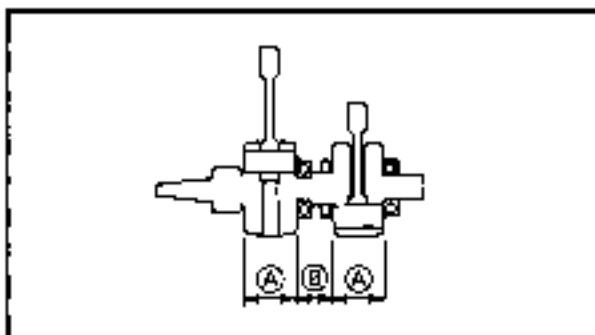

**Crankshaft inspection**

1. Measure:

- Crank width (A)
- Crank width (B)

Out of specification → Replace.



**Crank width (A):**

46.90 - 46.95 mm (1.846 - 1.848 in)

**Crank width (B):**

25.90 - 26.10 mm (1.020 - 1.028 in)

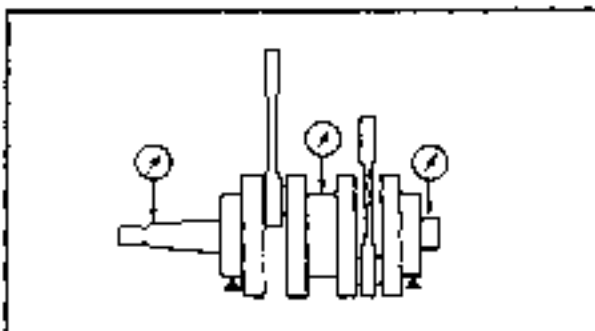

2. Measure:

- Runout

Use a V-blocks and dial gauge.

Out of specification → Replace.



**Runout limit:**

0.03 mm (0.001 in)

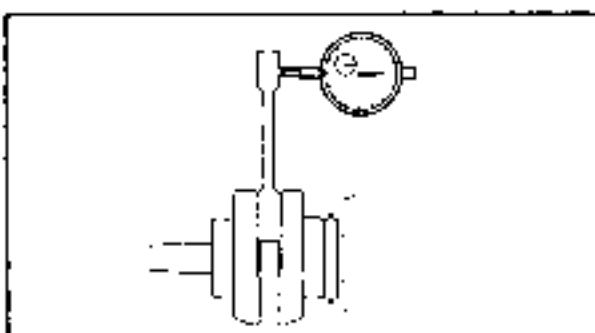

3. Measure:

- Axial play

Out of specification → Replace.



**Axial play limit:**

2.0 mm (0.08 in)

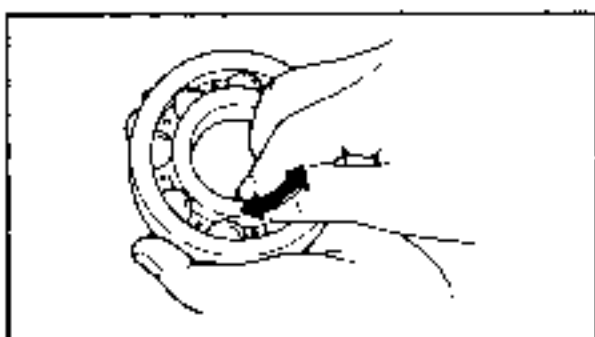

4. Inspect:

- Crankshaft bearing

Pitting/Rumbling → Replace.

**CAUTION:**

- Do not spin bearing with air blow; this can damage the bearing.
- Also take care not to scratch the bearing bells when cleaning.

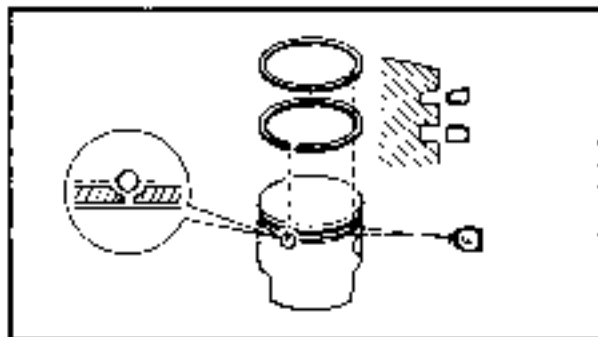

**Piston and piston ring installation**

1. Install:
  - Piston ring (2nd)
  - Piston ring (top)

**CAUTION:**

- Take care not to scratch the piston or break piston rings.
- Align the each ring end gap with their locating pins.
- After fitting the rings, check that they move smoothly.

**NOTE:**

Piston rings should be replaced as a set.

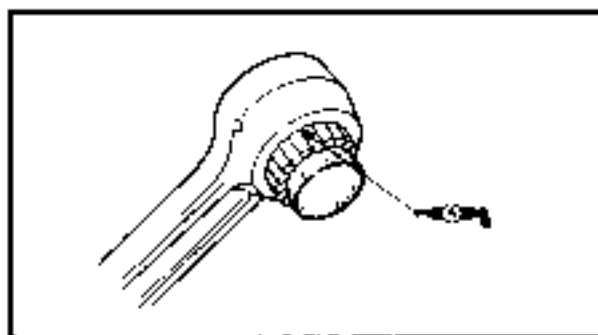

**Crankshaft and piston installation**

1. Install:
  - Small end bearing needle



**Needles per piston:**  
25 pieces



**Small end bearing needle installer:**  
YB-06104/90890-06543



## CHAPTER 6 LOWER UNIT

<b>LOWER UNIT REMOVAL</b> .....	6-1
EXPLODED DIAGRAM .....	6-1
REMOVAL AND INSTALLATION CHART .....	6-2
SERVICE POINTS .....	6-2
Propeller inspection .....	6-2
Lower unit installation .....	6-2
 <b>WATER PUMP</b> .....	 6-3
EXPLODED DIAGRAM .....	6-3
REMOVAL AND INSTALLATION CHART .....	6-4
SERVICE POINTS .....	6-4
Water pump housing inspection .....	6-4
Impeller and insert cartridge inspection .....	6-4
 <b>PROPELLER SHAFT AND REVERSE GEAR</b> .....	 6-5
EXPLODED DIAGRAM .....	6-5
REMOVAL AND INSTALLATION CHART .....	6-6
SERVICE POINTS .....	6-7
Propeller shaft housing removal .....	6-7
Propeller shaft housing disassembly .....	6-7
Reverse gear inspection .....	6-8
Bearing inspection .....	6-8
Propeller shaft housing inspection .....	6-8
Dog clutch inspection .....	6-8
Propeller shaft inspection .....	6-8
Propeller shaft housing assembly .....	6-8
 <b>DRIVE SHAFT, FORWARD GEAR AND SHIFT ROD</b> .....	 6-10
EXPLODED DIAGRAM .....	6-10
REMOVAL AND INSTALLATION CHART .....	6-11
SERVICE POINTS .....	6-12
Pinion nut removal and installation .....	6-12
Forward gear disassembly .....	6-12
Bearing housing disassembly and assembly .....	6-12
Lower case disassembly .....	6-12
Pinion and forward gear inspection .....	6-13
Drive shaft inspection .....	6-13
Shift cam inspection .....	6-13
Bearing inspection .....	6-13
Sleeve inspection .....	6-13
Lower case inspection .....	6-14
Lower case assembly .....	6-14
Drive shaft oil seal housing assembly .....	6-15
Forward gear assembly .....	6-15



<b>SHIMMING</b> .....	6-16
<b>EXPLODED DIAGRAM</b> .....	6-16
<b>SHIM SELECTION (FOR USA AND CANADA)</b> .....	6-17
Pinion gear shim .....	6-17
<b>SHIM SELECTION (EXCEPT FOR USA AND CANADA)</b> .....	6-19
Pinion gear shim .....	6-19
Forward gear shim .....	6-20
Reverse gear shim .....	6-21
<b>BACKLASH MEASUREMENT</b> .....	6-22
Forward gear .....	6-22
Reverse gear .....	6-23



LOWR



# LOWER UNIT REMOVAL

## LOWER UNIT REMOVAL EXPLODED DIAGRAM

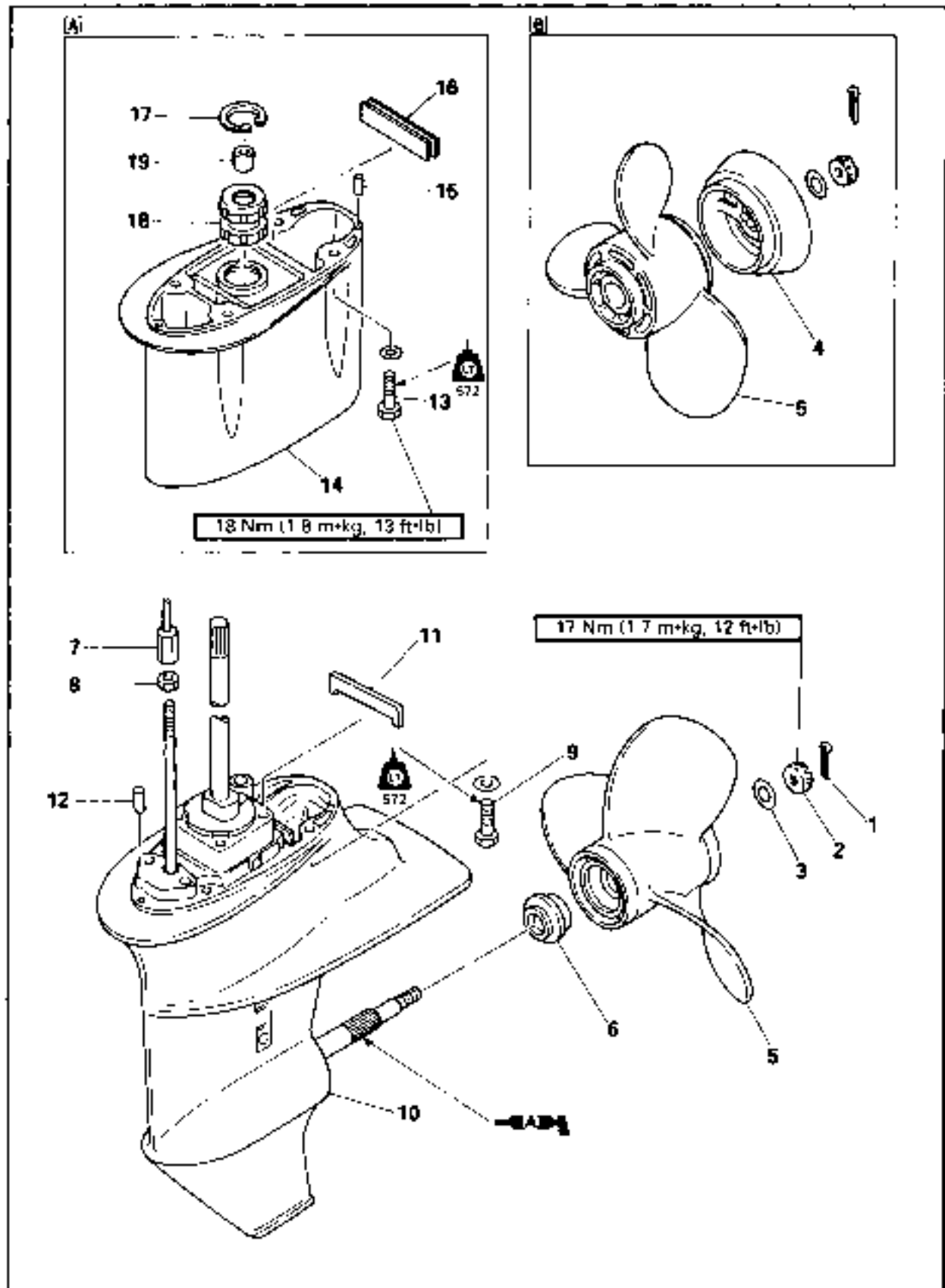



## REMOVAL AND INSTALLATION CHART

Step	Procedure/Part name	Q'ty	Service points
	<b>LOWER UNIT REMOVAL</b>		Follow the left "Step" for removal.
1	Cotter pin	1	
2	Propeller nut	1	<b>NOTE:</b> _____
3	Plane washer	1	
4	Deflection ring	1	If the propeller nut does not align with the propeller shaft hole when the nut is tightened to specification, turn it in further so that they align.
5	Propeller	1	
6	Spacer	1	
7	Adjusting nut	1	<b>NOTE:</b> _____
8	Locknut	1	
9	Bolt (with washer)	4	When connecting the adjusting nut, set the shift lever and shift cam to reverse position.
10	Lower unit	1	<b>NOTE:</b> _____
11	Seal rubber	1	
12	Pin	2	Insert the drive shaft into the crankshaft. If the splines will not come in complete mesh, rotate the propeller shaft a little so that they are in mesh correctly.
13	Bolt (with washer)	4	
14	Extension	1	
15	Pin	2	
16	Seal rubber	1	
17	Circlip	1	
18	Damper	1	
19	Bushing	1	
			Reverse the removal steps for installation.

: For super long model

: For dual thrust model

**SERVICE POINTS****Propeller inspection**

## 1. Inspect:

- Blade
- Spline

Wear/Crack/Damage → Replace.

**Lower unit installation**

## 1. Install:

- Adjusting nut

 **WARNING**

The adjusting nut should be screwed in more than 8 mm (0.31 in).

LOWR



WATER PUMP

WATER PUMP  
EXPLODED DIAGRAM

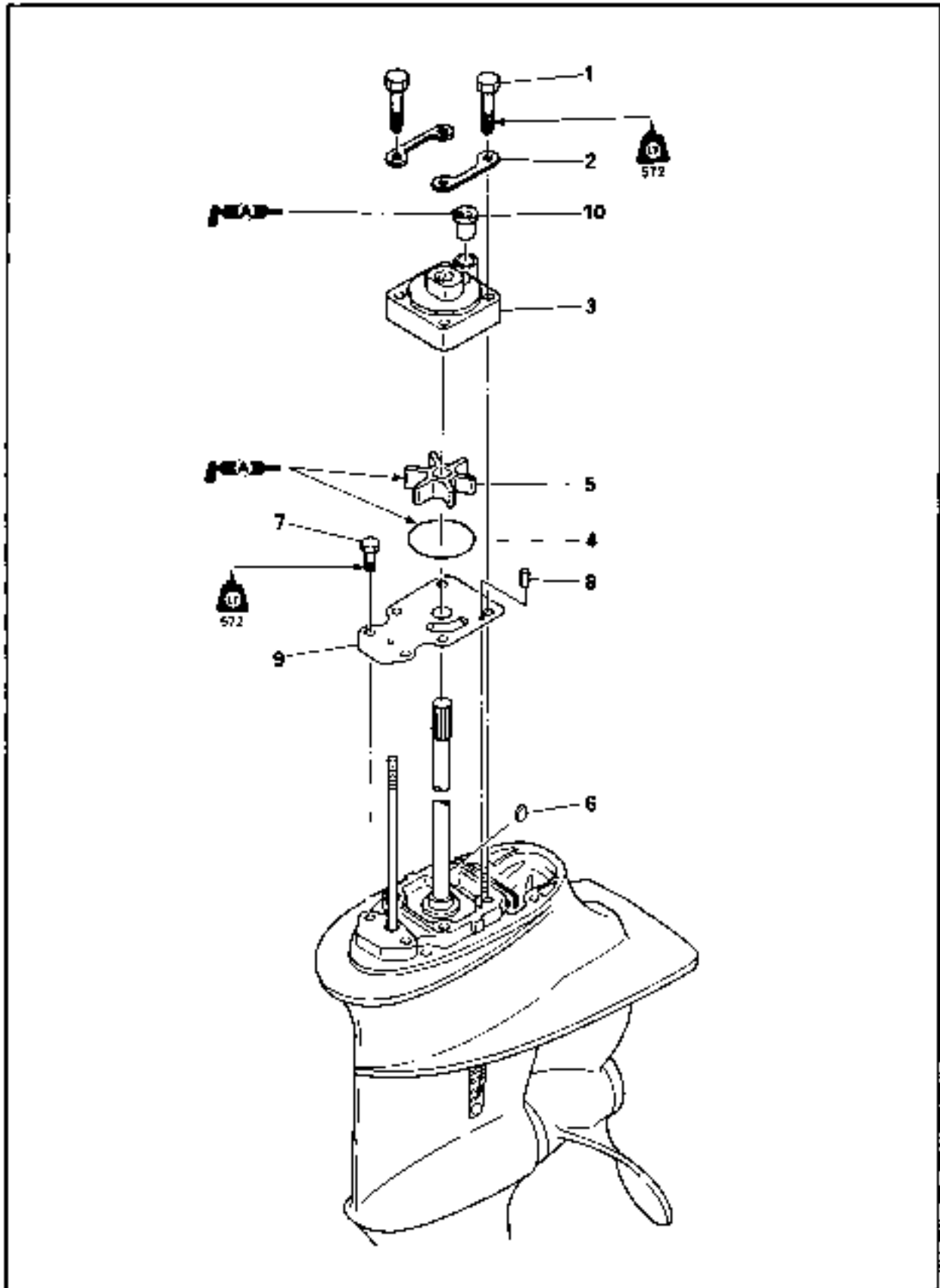



**REMOVAL AND INSTALLATION CHART**

Step	Procedure/Part name	Qty	Service points
	<b>WATER PUMP REMOVAL</b>		Follow the left "Step" for removal.
	Lower unit assembly		Refer to the "LOWER UNIT REMOVAL" section.
1	Bolt	4	
2	Plate	2	
3	Water pump housing	1	<b>NOTE:</b>
4	O-ring	1	When installing the water pump housing, turn the drive shaft clockwise.
5	Impeller	1	
6	Woodruff key	1	
7	Bolt	2	8 x 25 mm
8	Pin	2	
9	Cartridge plate	1	
10	Water seal rubber	1	
			Reverse the removal steps for installation.

**SERVICE POINTS**

**Water pump housing inspection**

1. Inspect:
  - Water pump housing  
Crack/Damage → Replace.

**Impeller and insert cartridge inspection**

1. Inspect:
  - Impeller
  - Insert cartridge  
Crack/Damage → Replace.

PROPELLER SHAFT AND REVERSE GEAR  
EXPLODED DIAGRAM

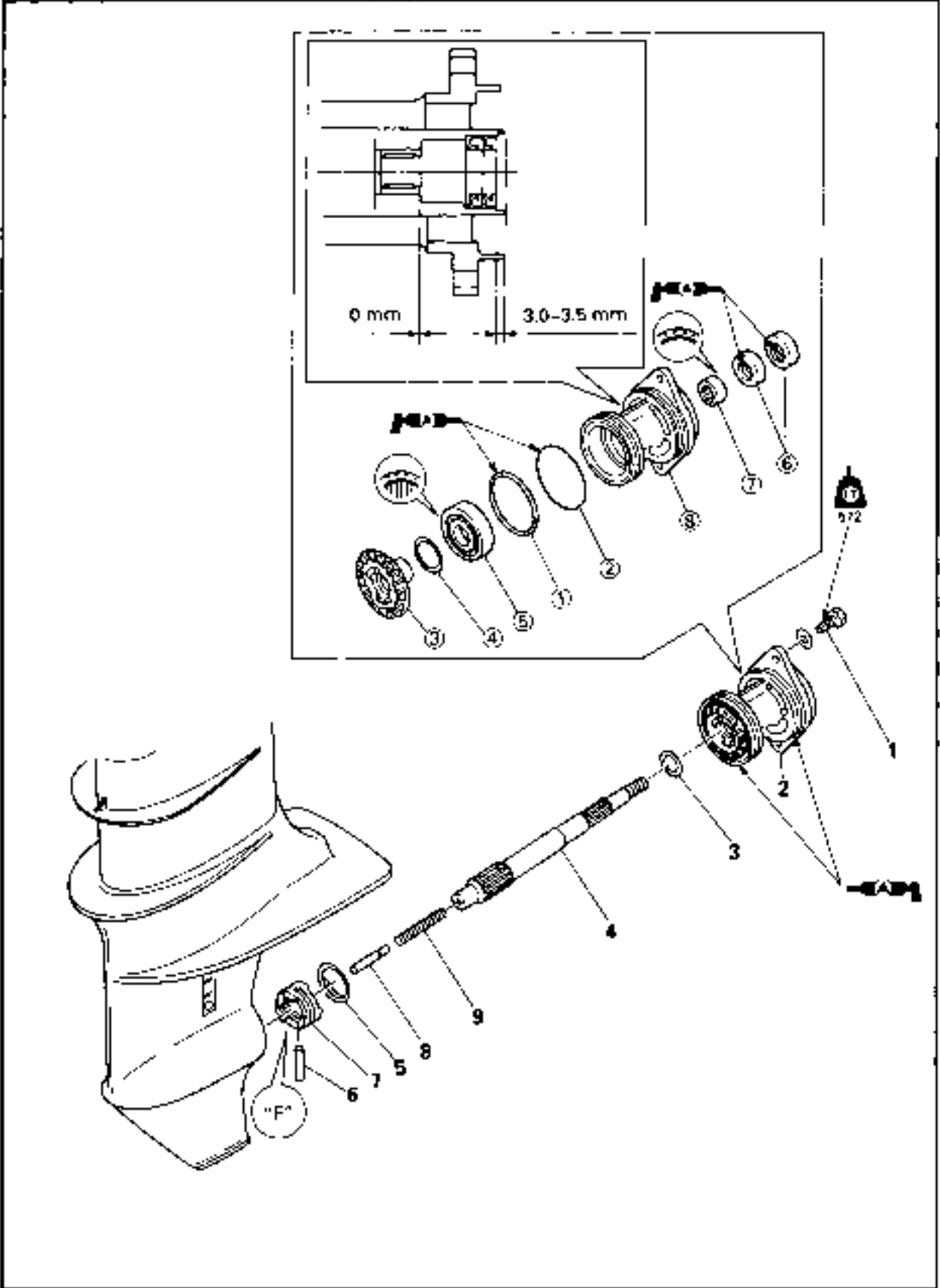



**REMOVAL AND INSTALLATION CHART**

Step	Procedure/Part name	Qty	Service points
	<b>PROPELLER SHAFT AND REVERSE GEAR REMOVAL</b>		Follow the left "Step" for removal.
	Gear oil		Refer to the "LOWER UNIT" section in chapter 3.
	Propeller		Refer to the "LOWER UNIT REMOVAL" section.
1	Bolt (with washer)	2	8 x 20 mm
2	Propeller shaft housing assembly	1	
3	Plate washer	1	
4	Propeller shaft	1	
5	Cross pin ring	1	
6	Cross pin	1	<b>NOTE:</b> By pushing the shift plunger, bring the cross pin hole in the dog clutch with the hole in the shift slider
7	Dog clutch	1	<b>NOTE:</b> Install the clutch with "F" mark toward the forward gear side.
8	Shift plunger	1	
9	Spring	1	
	<b>PROPELLER SHAFT HOUSING DISASSEMBLY</b>		
①	O-ring	1	
②	O-ring	1	
③	Reverse gear	1	
④	Reverse gear shim	*	
⑤	Ball bearing	1	
⑥	Oil seal	2	
⑦	Needle housing	1	
⑧	Propeller Shaft housing	1	
			Reverse the removal steps for installation.

\*: As required

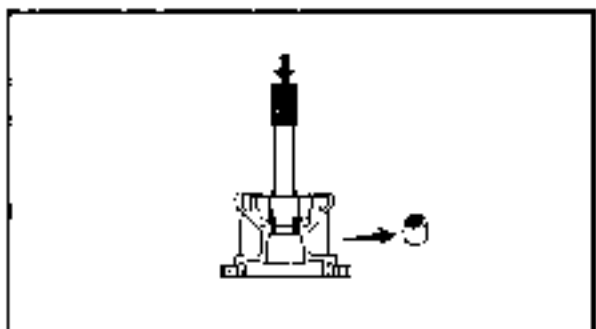
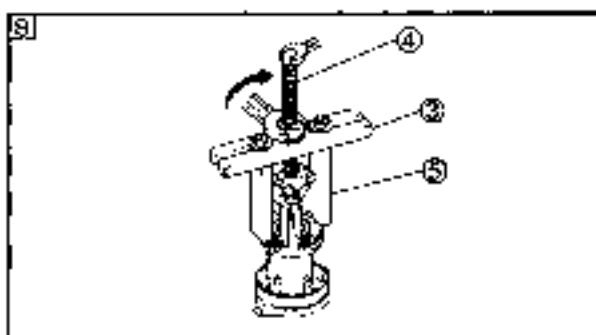
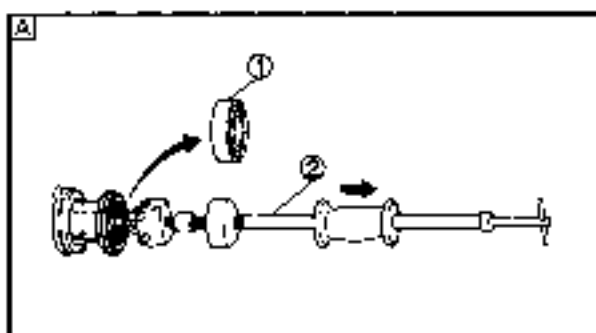
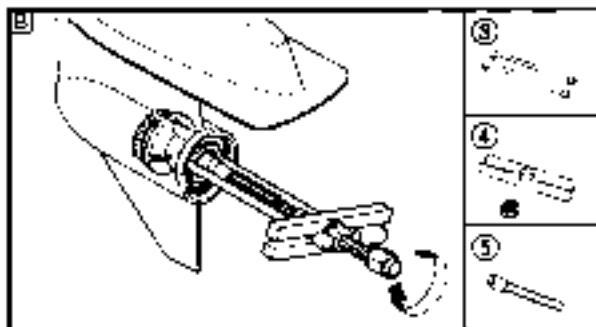
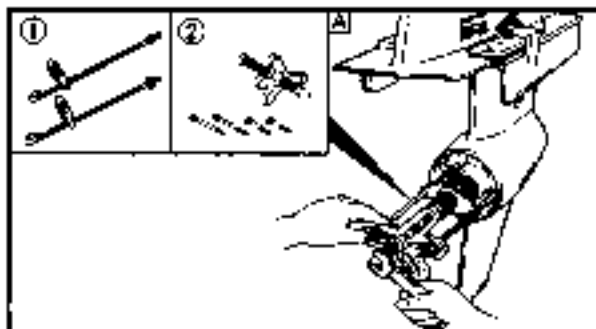
**LOWR****PROPELLER SHAFT AND REVERSE GEAR****SERVICE POINTS****Propeller shaft housing removal**

- Remove:
  - Propeller shaft housing assembly

**Bearing housing puller:**

YB-06234 ..... ①  
90890-06503 ..... ③

**Universal puller:**

YB-06117 ..... ②

**Stopper guide plate:**

90890-06501 ..... ④

**Center bolt:**

90890-06504 ..... ⑤

A For USA and CANADA

B Except for USA and CANADA

**Propeller shaft housing disassembly**

- Remove:
  - Ball bearing ①

**Slide hammer set:**

YB-06096 ..... ②

**Stopper guide plate:**

90890-06501 ..... ③

**Bearing puller:**

90890-06535 ..... ④

**Stopper guide stand:**

90890-06538 ..... ⑤

A For USA and CANADA

B Except for USA and CANADA

- Remove:
  - Needle bearing

**Driver rod:**

YB-06071/90890-06604

**Needle bearing attachment:**

YB-06081/90890-06616

**Reverse gear inspection**

1. Inspect:
  - Tooth
  - Dog
 Wear/Damage → Replace.

**Bearing inspection**

1. Inspect:
  - Bearing
 Pitting/Rumbling → Replace.

**Propeller shaft housing inspection**

1. Clean:
  - Propeller shaft housing
 Use a soft brush and solvent.
2. Inspect:
  - Propeller shaft housing
 Crack/Damage → Replace.

**Dog clutch inspection**

1. Inspect:
  - Dog clutch
 Wear/Damage → Replace.

**Propeller shaft inspection**

1. Inspect:
  - Propeller shaft
 Wear/Damage → Replace.

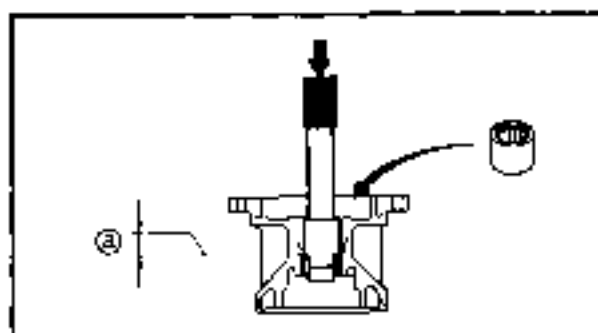
**Propeller shaft housing assembly**

1. Install:
  - Needle bearing

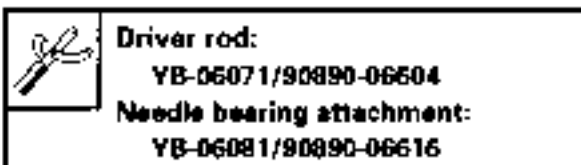
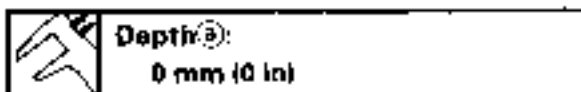



LOWR



## PROPELLER SHAFT AND REVERSE GEAR

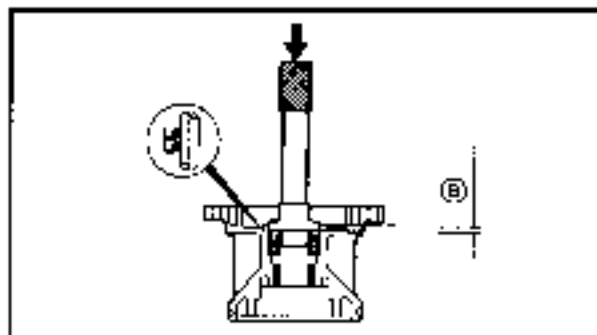

2. Install:
- Oil seal



Depth (a):  
3.0 - 3.5 mm (0.12 - 0.14 in)



Oil seal installer:  
YB-06168  
Driver rod:  
YB-06071

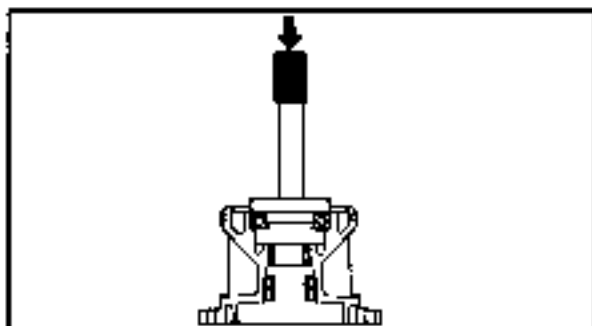

3. Install:
- Ball bearing



Bearing installer:  
YB-06015  
Driver rod:  
YB-06071

LOWR



# DRIVE SHAFT, FORWARD GEAR AND SHIFT ROD

## DRIVE SHAFT, FORWARD GEAR AND SHIFT ROD

EXPLODED DIAGRAM

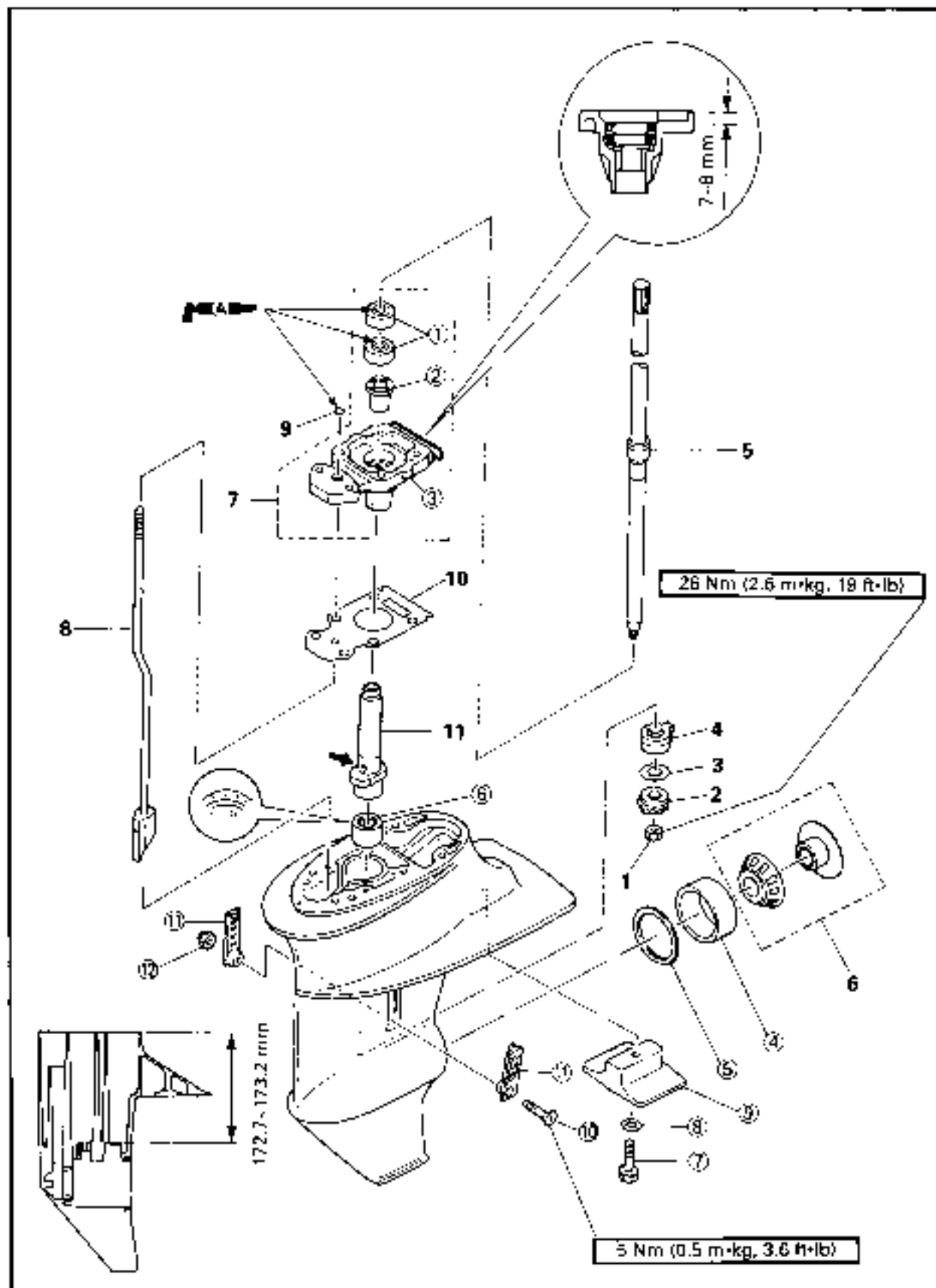



## REMOVAL AND INSTALLATION CHART

Step	Procedure/Part name	Q'ty	Service points
	<b>DRIVE SHAFT, FORWARD GEAR AND SHIFT ROD REMOVAL</b>		Follow the left "Step" for removal.
	Propeller shaft		Refer to the "PROPELLER SHAFT AND REVERSE GEAR" section.
	Impeller		Refer to the "WATER PUMP" section.
1	Pinion nut	1	
2	Pinion gear	1	
3	Shim	1	
4	Thrust bearing	1	
5	Drive shaft	1	
6	Forward gear assembly	1	
7	Bearing housing	1	
8	Shift rod	1	
9	O-ring	1	
10	Bearing housing gasket	1	
11	Sleeve	1	<b>NOTE:</b> _____ Install the sleeve with its hole forward.
	<b>BEARING HOUSING DISASSEMBLY</b>		
①	Oil seal	2	
②	Bushing	1	
③	Bearing housing	1	
	<b>LOWER CASE DISASSEMBLY</b>		
④	Forward gear bearing outer race	1	
⑤	Forward gear shim	1	
⑥	Needle bearing	1	
⑦	Bolt	1	8 x 30 mm
⑧	Toothed washer	1	
⑨	Anode	1	
⑩	Screw	1	
⑪	Water inlet cover	2	
⑫	Nut	1	
			Reverse the removal steps for installation.

\*:As required

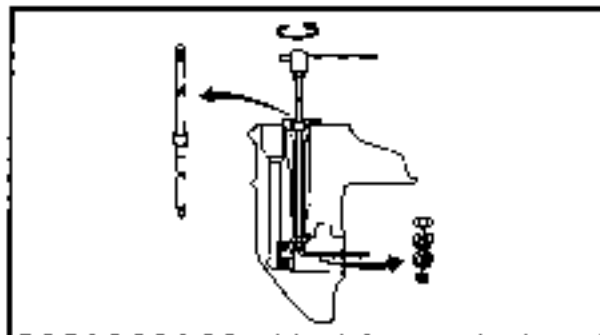

**SERVICE POINTS**

**Pinion nut removal and installation**

1. Remove and install:
  - Pinion nut



**Drive shaft holder:**

YB-06228/90890-06516

**Pinion nut holder:**

YB-0607B

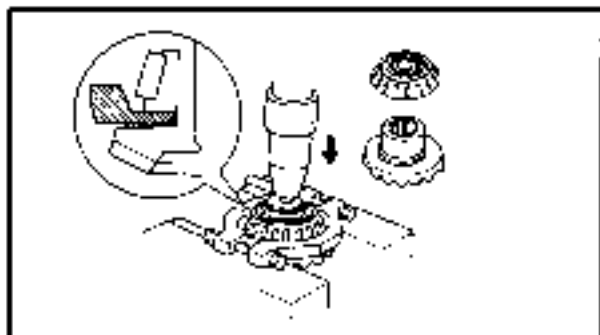

**Forward gear disassembly**

1. Remove:
  - Taper roller bearing
  - Forward gear



**Bearing separator:**

YB-06219/90890-06534

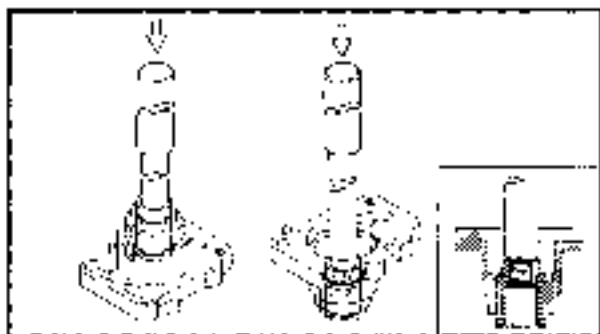

**Bearing housing disassembly and assembly**

1. Remove and install:
  - Bushing



**Bushing attachment:**

YB-06028/90890-06648

**Driver rod:**

YB-08229/90890-06652

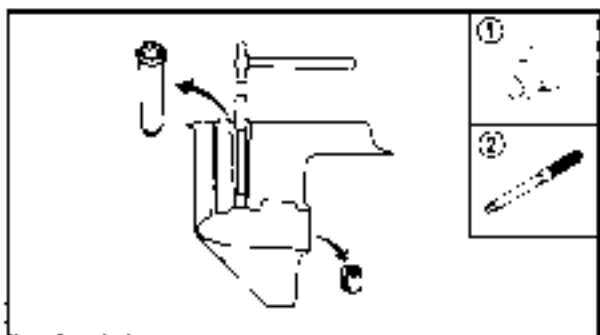

**Lower case disassembly**

1. Remove:
  - Drive shaft needle bearing



**Needle bearing attachment:**

YB-06230/90890-06617 ..... ①

**Driver rod:**

YB-06229/90890-06602 ..... ②

**LOWR**



## DRIVE SHAFT, FORWARD GEAR AND SHIFT ROD

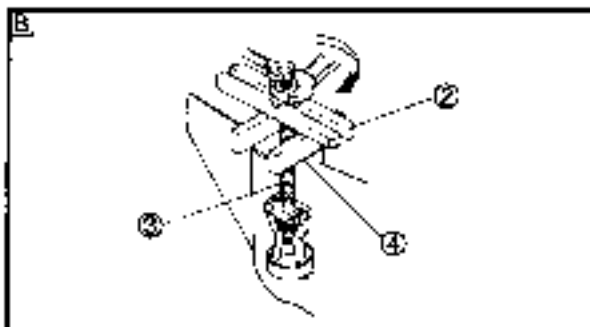
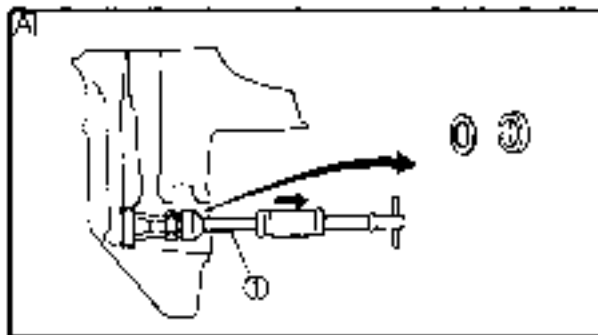

### 2. Remove:

- Forward gear bearing outer race



#### Slide hammer set:

YB-06086 ..... ①

#### Stopper guide plate:

90890-06501 ..... ②

#### Bearing outer race puller:

90890-06535 ..... ③

#### Stopper guide stand:

90890-06538 ..... ④

A. For USA and CANADA

B. Except for USA and CANADA

### Pinion and forward gear inspection

#### 1. Inspect:

- Tooth
  - Dog
- Wear/Damage → Replace.

### Drive shaft inspection

#### 1. Inspect:

- Drive shaft
- Wear/Damage → Replace.

### Shift cam inspection

#### 1. Inspect:

- Shift cam
- Wear/Damage → Replace.

### Bearing inspection

#### 1. Inspect:

- Bearing
- Pitting/Rumbling → Replace.

### Sleeve inspection

#### 1. Inspect:

- Sleeve
- Wear/Damage → Replace.



**Lower case inspection**

1. Clean:
  - Gear case
    - Use a soft brush and solvent.
2. Inspect:
  - Water passage
    - Mineral deposits/Corrosion → Clean.
3. Inspect:
  - Lower case
    - Crack/Damage → Replace.

**Lower case assembly**

1. Install:
  - Forward gear shim ①
  - Forward gear bearing outer race ②

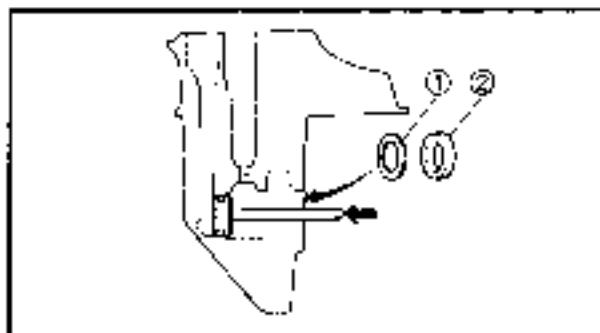

	<b>Bearing installer:</b>
	YB-06005/90890-06625
	<b>Driver rod:</b>
	YB-06071/90890-06605

2. Install:
  - Drive shaft needle bearing

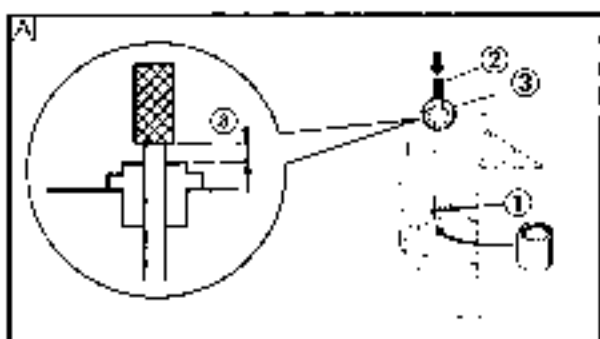

	<b>Depth ③:</b>
	17.8 mm (0.70 in)
	<b>Depth ④:</b>
	172.7~173.2 mm (6.80~6.82 in)

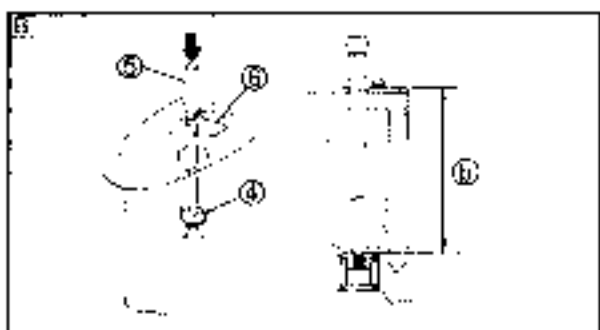

	<b>Bearing attachment:</b>	
	YB-06230.....	①
	90890-06617.....	④
	<b>Driver rod:</b>	
	YB-06229.....	②
	90890-06602.....	⑤
	<b>Driveshaft needle bearing</b>	
	<b>depth stop:</b>	
	YB-06231.....	③
	<b>Bearing depth plate:</b>	
	90890-06603.....	⑥

A For USA and CANADA  
 B Except for USA and CANADA

LOWR



## DRIVE SHAFT, FORWARD GEAR AND SHIFT ROD

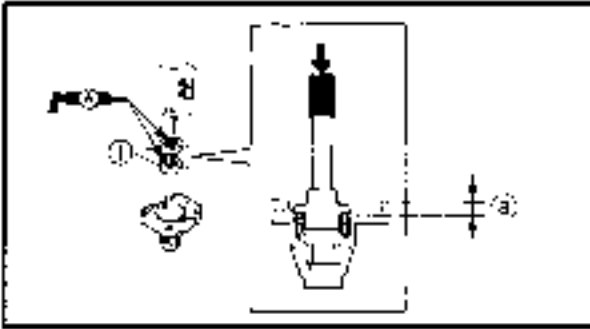

### Drive shaft oil seal housing assembly

1. Install:

- Oil seal



Depth a):

7.0 - 8.0 mm (0.28 - 0.31 in)



Bearing Installer:

YB-06022

Driver rod:

YB-06071

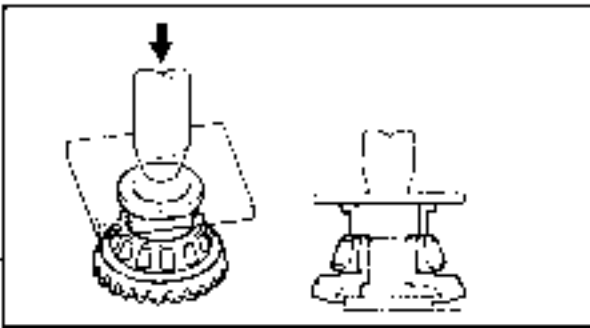

### Forward gear assembly

1. Install:

- Forward gear
- Taper roller bearing



Bearing installer:

90890-06644



SHIMMING  
EXPLODED DIAGRAM

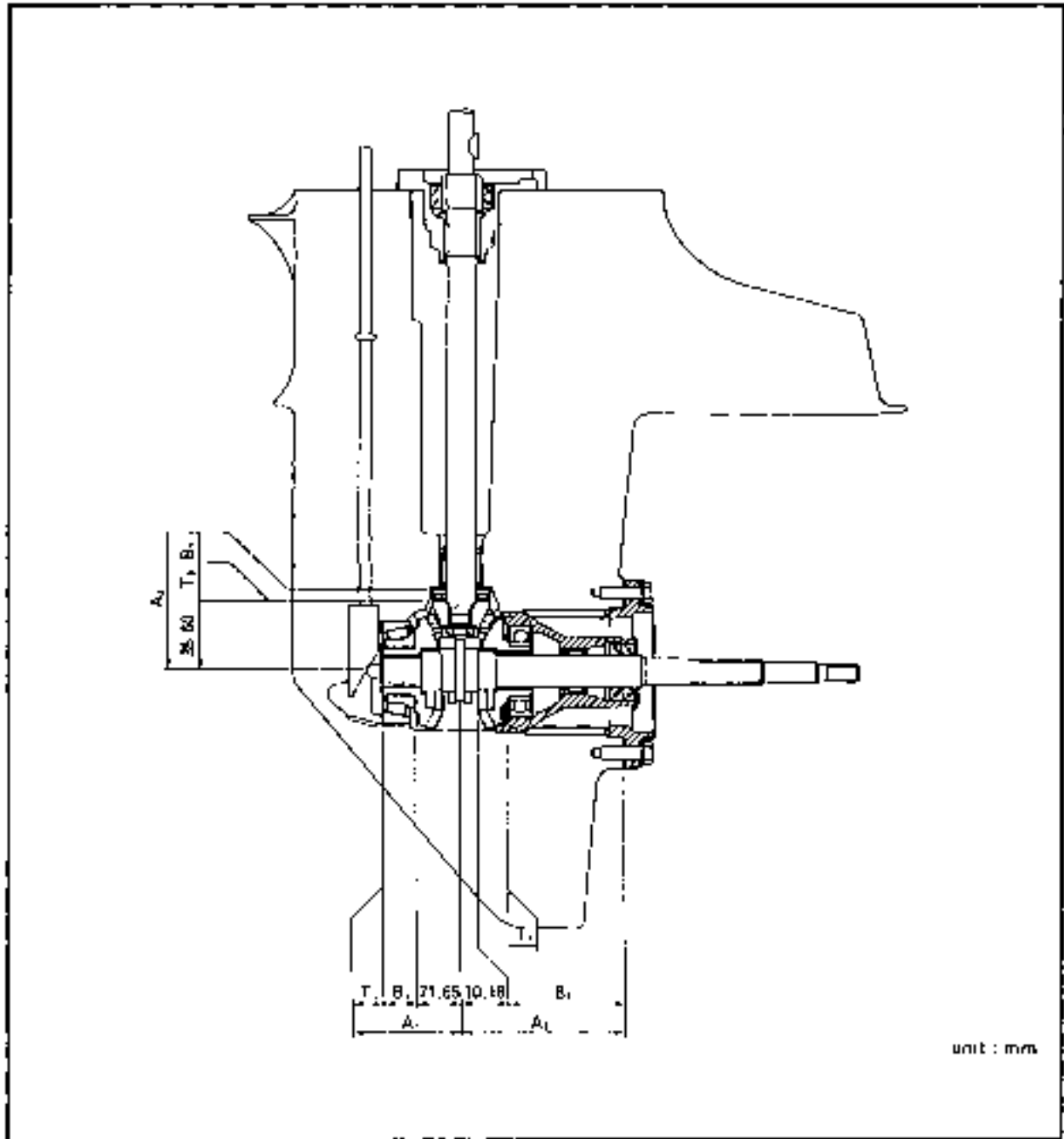



**NOTE:**

Shim selection requirement guide:

- Not required when;  
reassembling with original case and inner parts.
- Numeric calculation is required when;  
reassembling with original inner parts and the new case. (Difference between original and new case)
- Measurement and adjustment is required when;  
replacing the inner part(s).

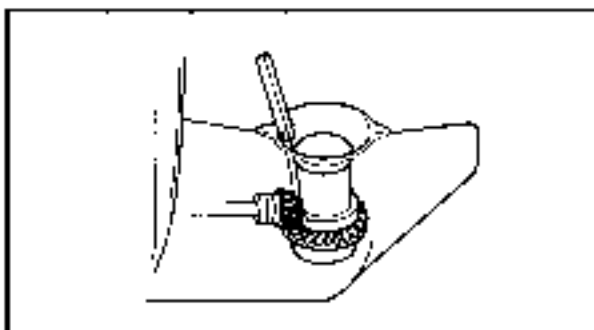
**SHIM SELECTION (FOR USA AND CANADA)****Pinion gear shim**

## 1. Measure:

- Pinion gear clearance  
Out of specification → Adjust.

**Clearance:**

1.15 - 1.25 mm

**Measuring steps:**

- Install the drive shaft components and tighten the pinion nut.

**Pinion nut:**

26 Nm (2.6 m • kg, 19 ft • lb)

- Attach the shimming tool into the gear case.

**Pinion height gauge:**

YB-34232

- ♦ Measure the clearance and determine the shim thickness.

Less than  
1.15 mm

To be decreased by  
(1.20 • measurement)

More than  
1.25 mm

To be increased by  
(measurement • 1.20)



Example:

If measurement = 1.02 mm  
decrease shim thickness by  
= 1.20 - 1.02  
= 0.18 mm

If measurement = 1.32 mm  
increase shim thickness by  
= 1.32 - 1.20  
= 0.12 mm



**Available shim thickness:**

**1.13 and 1.20 mm**

**NOTE:**

Find forward and reverse gear shim thickness  
by backlash measurement.



## SHIM SELECTION (EXCEPT FOR USA AND CANADA)

### Pinion gear shim

#### NOTE:

Find pinion gear shim thickness (T3) by selecting shims until the specified measurement is obtained with the special tool.

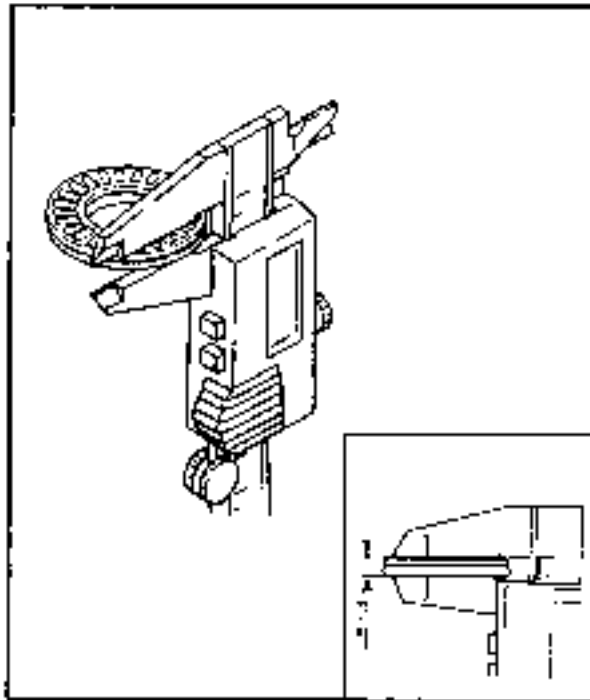

#### 1. Measure:

- Measurement (M)



**Digital caliper:**  
90890-06704

#### NOTE:

Measure the thicknesses (Mv3) of bearing and washer.

#### 2. Calculate:

- Pinion gear shim thickness (T3)



**Pinion gear shim thickness (T3)  $\approx 6.05 - Mv3$  mm**

#### 3. Select:

- Pinion gear shim

Calculated numeral		Using shim
more than	or less	
1.13	1.20	1.13
1.20	1.30	1.20

**Available shim thickness:**  
1.13 and 1.20 mm

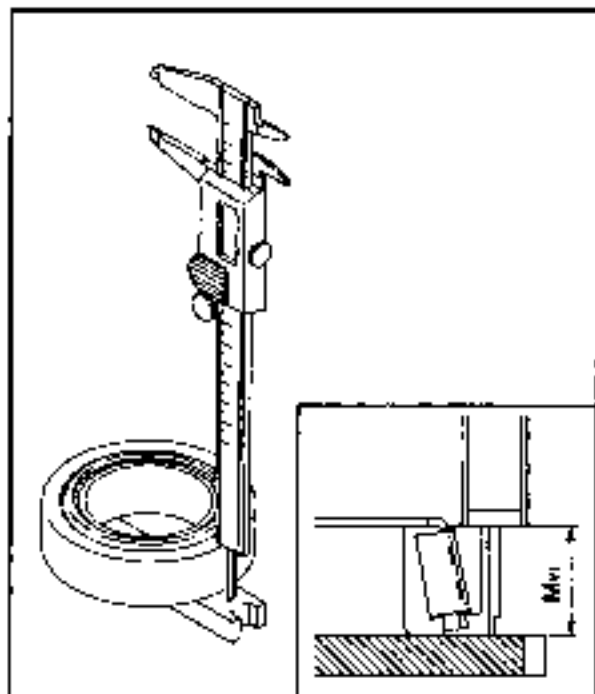

### Forward gear shim

#### NOTE:

Find forward gear shim thickness (T1) by selecting shims until the specified measurement (M) is obtained with the special tool.

1. Measure:
  - Measurement (M)



**Shimming plate:**

90890-06701

**Digital caliper:**

90890-06704

#### NOTE:

Measure the length between the shimming plate and the bearing outer race after turning the outer race 2 to 3 times.

2. Calculate:
  - Forward gear shim thickness (T1)



**Forward gear shim thickness**

$$(T1) = 16.60 \cdot Mv1$$

3. Select:
  - Forward gear shim

Calculated numeral at 1/100th place		Rounded numeral
more than	or less	
0.00	0.02	0.00
0.02	0.05	0.02
0.05	0.08	0.05
0.08	0.10	0.08



**Available shim thickness:**

0.10, 0.12, 0.15, 0.18, 0.30, 0.40  
and 0.50 mm

Example:

If T1 is "0.44 mm",  
then forward gear shim = 0.42 mm

If T1 is "0.45 mm",  
then forward gear shim = 0.45 mm



**Reverse gear shim**

**NOTE:**

Find reverse gear shim thickness (T2) by selecting shims until the specified measurement (M) is obtained with the special tool.

**1. Measure:**

- Measurement (M)

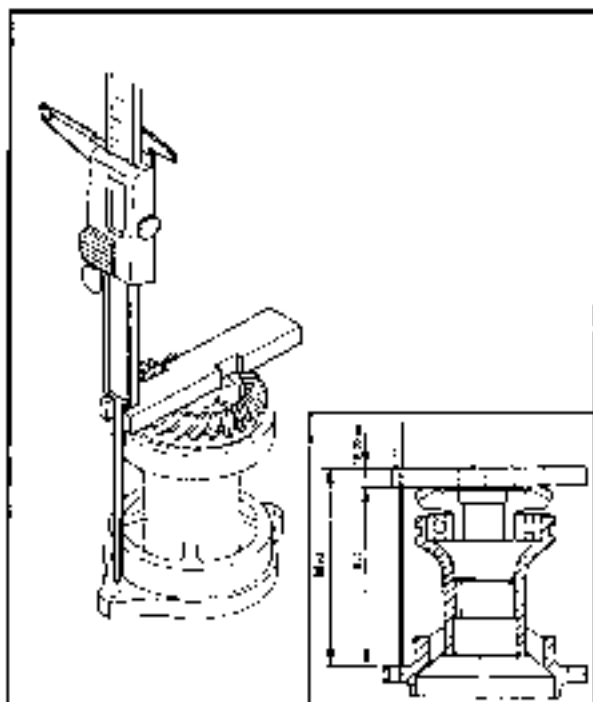

**Shimming plate:**

**90890-06701**

**Digital caliper:**

**90890-06704**

**NOTE:**

Remove the shim(s) before measurement.

**2. Calculate:**

- Reverse gear shim thickness (T2)



**Reverse gear shim thickness  
(T2) = 80.57 - Mv2**

**3. Select:**

- Reverse gear shim

Calculated numeral		Using shim
more than	or less	
0.30	0.40	0.30
0.40	0.50	0.40
0.50	0.60	0.50
0.60	0.70	0.60



**Available shim thickness:**

**0.10, 0.20, 0.30, 0.40 and 0.50 mm**



## BACKLASH MEASUREMENT

### NOTE:

- Do not install the water pump components when measuring the backlash.
- Both forward and reverse gear backlashes should be measured.
- If both the forward and reverse gear backlashes are large than specified, the pinion may be too high.
- If both forward and reverse gear backlashes are smaller than specified, the pinion may be too low.
- If either of these conditions exists, then check the pinion shim selection.

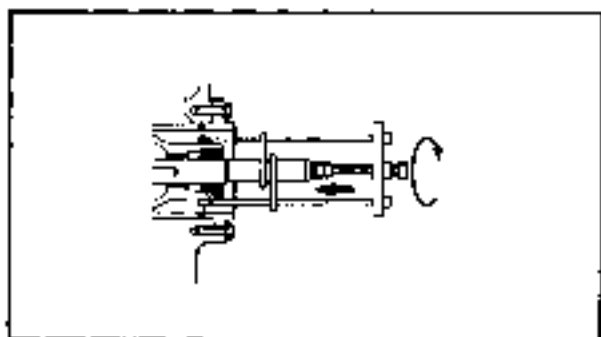
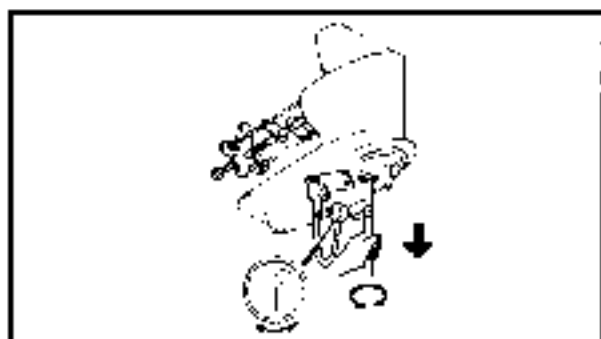

### Forward gear

#### 1. Measure:

- Forward gear backlash  
Out of specification → Adjust.



#### Backlash:

0.19 - 0.86 mm (0.007 - 0.034 in)

#### Measuring steps:

- Set the shift shaft in the forward position.
- Set the bearing housing puller for pushing the propeller shaft.



#### Bearing housing puller:

YB-06234/90890-06503

#### Universal puller:

YB-06117

#### Stopper guide plate:

90890-06501

#### Center bolt:

90890-06504



#### Center bolt:

5 Nm (0.5 m • kg, 3.6 ft • lb)

- Set the lower unit upside down.
- Attach the backlash indicator on the drive shaft (12.8 mm in diameter).



#### Backlash indicator:

YB-06265/90890-06706

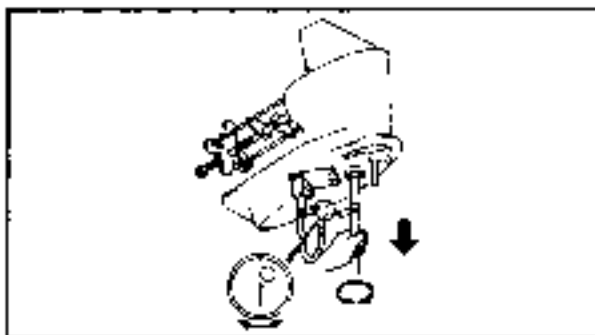
**LOWR****SHIMMING**

- Attach the dial gauge on the lower case, and make the dial gauge stem contact the mark on the indicator.

**Backlash adjusting plate:****YB-07003****Dial gauge:****YU-03097/90890-01252****Magnet base:****YU-34481/90890-06705**

- While pulling the drive shaft, slowly turn the drive shaft clockwise and counterclockwise; then, measure the backlash when the drive shaft stops in each direction.

**2. Adjust:**

- Forward gear shim(s)

**NOTE:**

Adjust the shim(s) to be added or removed according to specification.

 Forward gearbacklash	Shim thickness
Less than 0.19 mm	To be decreased by (0.53 - measurement) 2.1
More than 0.86 mm	To be increased by (measurement - 0.53) 2.1
Available shim thickness: 0.10, 0.12, 0.15, 0.18, 0.30, 0.40 and 0.50 mm	

**Reverse gear****1. Measure:**

- Reverse gear backlash

Out of specification → Adjust.

**Backlash:****0.95 - 1.65 mm (0.037 - 0.065 in)**

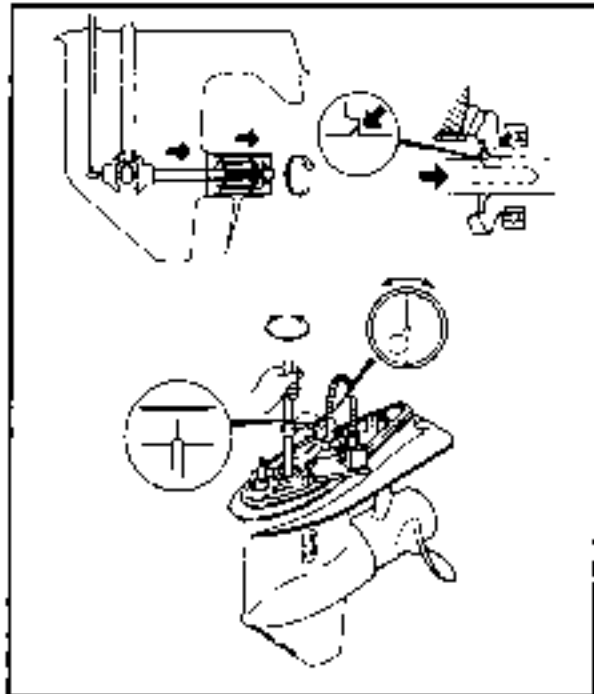
**Measuring steps:**

- Set the shift shaft in the reverse position.
- Load the reverse gear by installing the propeller with the front side facing backward, and tighten the propeller nut.

**Propeller nut:**

5 Nm (0.5 m • kg, 3.6 ft • lb)

- Attach the backlash indicator on the drive shaft (12.8 mm in diameter).

**Backlash indicator:**

YB-06265/90890-06706

- Attach the dial gauge on the lower case, and make the dial gauge stem contact the mark on the indicator.

**Backlash adjusting plate:**

YB-07003

**Dial gauge:**

YU-03097/90890-01252

**Magnet base:**

YU-34481/90890-06705

- While pulling the drive shaft, slowly turn the drive shaft clockwise and counterclockwise; then, measure the backlash when the drive shaft stops at each direction.

**2. Adjust:**

- Reverse gear shim(s)

**NOTE:**

Adjust the shim(s) to be added or removed according to specification.



**Reverse  
gear backlash**

**Shim thickness**

Less than 0.95 mm	To be decreased by
	$ 1.30 - \text{measurement} $
More than 1.65 mm	To be increased by
	$ \text{measurement} - 1.30 $

2.1

2.1

**Available shim thickness:**

0.10, 0.20, 0.30, 0.40 and 0.50 mm





## CHAPTER 7 BRACKET UNIT

<b>STEERING HANDLE AND SHIFT LEVER</b> .....	7-1
EXPLODED DIAGRAM .....	7-1
REMOVAL AND INSTALLATION CHART .....	7-2
<b>SERVICE POINTS</b> .....	7-3
Control cable inspection .....	7-3
Bushing inspection .....	7-3
Friction piece inspection .....	7-3
Steering handle inspection .....	7-3
Throttle shaft inspection .....	7-3
 <b>BOTTOM COWLING</b> .....	 7-4
EXPLODED DIAGRAM .....	7-4
REMOVAL AND INSTALLATION CHART .....	7-5
 <b>UPPER CASE AND EXHAUST MANIFOLD</b> .....	 7-6
EXPLODED DIAGRAM .....	7-6
REMOVAL AND INSTALLATION CHART .....	7-7
<b>SERVICE POINTS</b> .....	7-8
Rubber mount inspection .....	7-8
Mount bolt inspection .....	7-8
 <b>CLAMP BRACKET</b> .....	 7-9
EXPLODED DIAGRAM .....	7-9
REMOVAL AND INSTALLATION CHART .....	7-10
 <b>STEERING AND SWIVEL BRACKET</b> .....	 7-11
EXPLODED DIAGRAM .....	7-11
REMOVAL AND INSTALLATION CHART .....	7-12



### STEERING HANDLE AND SHIFT LEVER EXPLODED DIAGRAM

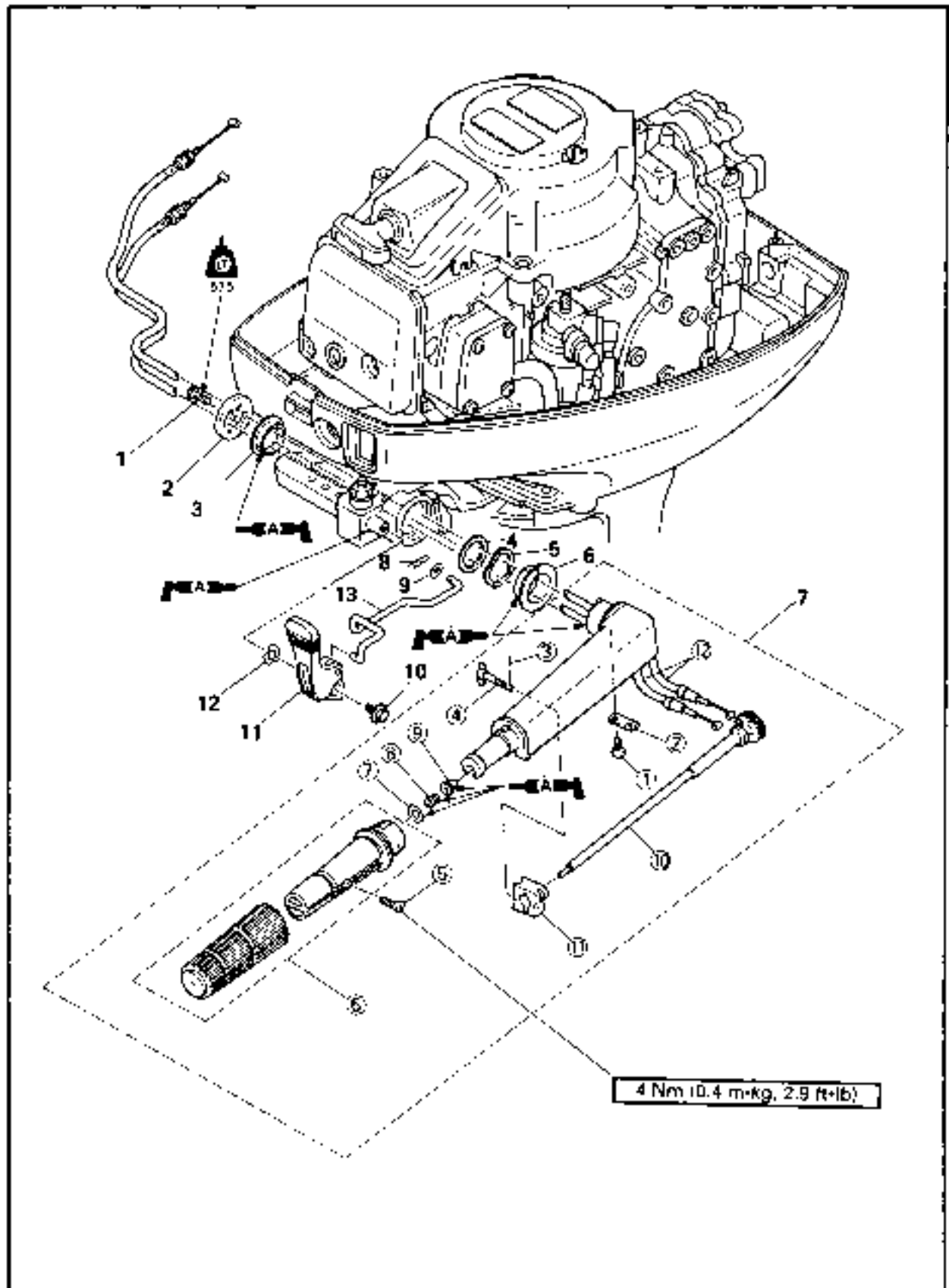



## REMOVAL AND INSTALLATION CHART AND SHIFT LEVER

Step	Procedure/Part name	Q'ty	Service points
<b>STEERING HANDLE REMOVAL</b>			Follow the left "Step" for removal. Refer to the "POWER UNIT REMOVAL" section in chapter 5. 6 X 16 mm
	Control pulley bracket assembly		
1	Bolt	1	
2	Plate	1	
3	Bushing	1	
4	Plane washer	1	
5	Wave washer	1	
6	Bushing	1	
7	Steering handle assembly	1	
<b>SHIFT LEVER REMOVAL</b>			
8	Clip	1	
9	Plane washer	1	
10	Bolt	1	6 x 12 mm
11	Shift lever	1	
12	Wave washer	1	
13	Shift link rod	1	
<b>STEERING HANDLE DISASSEMBLY</b>			
①	Screw	2	
②	Plate	1	
③	Clip	1	
④	Friction adjusting screw	1	
⑤	Screw	1	
⑥	Steering grip	1	
⑦	Plane washer	1	
⑧	Spring	1	
⑨	Bushing	1	
⑩	Throttle shaft	1	
⑪	Friction piece	1	
⑫	Throttle cable	2	
			Reverse the removal steps for installation.

**SERVICE POINTS****Control cable inspection**

1. Inspect:
  - Throttle cable  
Kink/Fray/Stick → Replace.

**Bushing inspection**

1. Inspect:
  - Bushing  
Wear/Crack/Damage → Replace.

**Friction piece inspection**

1. Inspect:
  - Friction piece  
Wear/Crack/Damage → Replace.

**Steering handle inspection**

1. Inspect:
  - Steering handle  
Wear/Crack/Damage → Replace.

**Throttle shaft inspection**

1. Inspect:
  - Throttle shaft  
Wear/Bent/Damage → Replace.



**BOTTOM COWLING**  
**EXPLODED DIAGRAM**

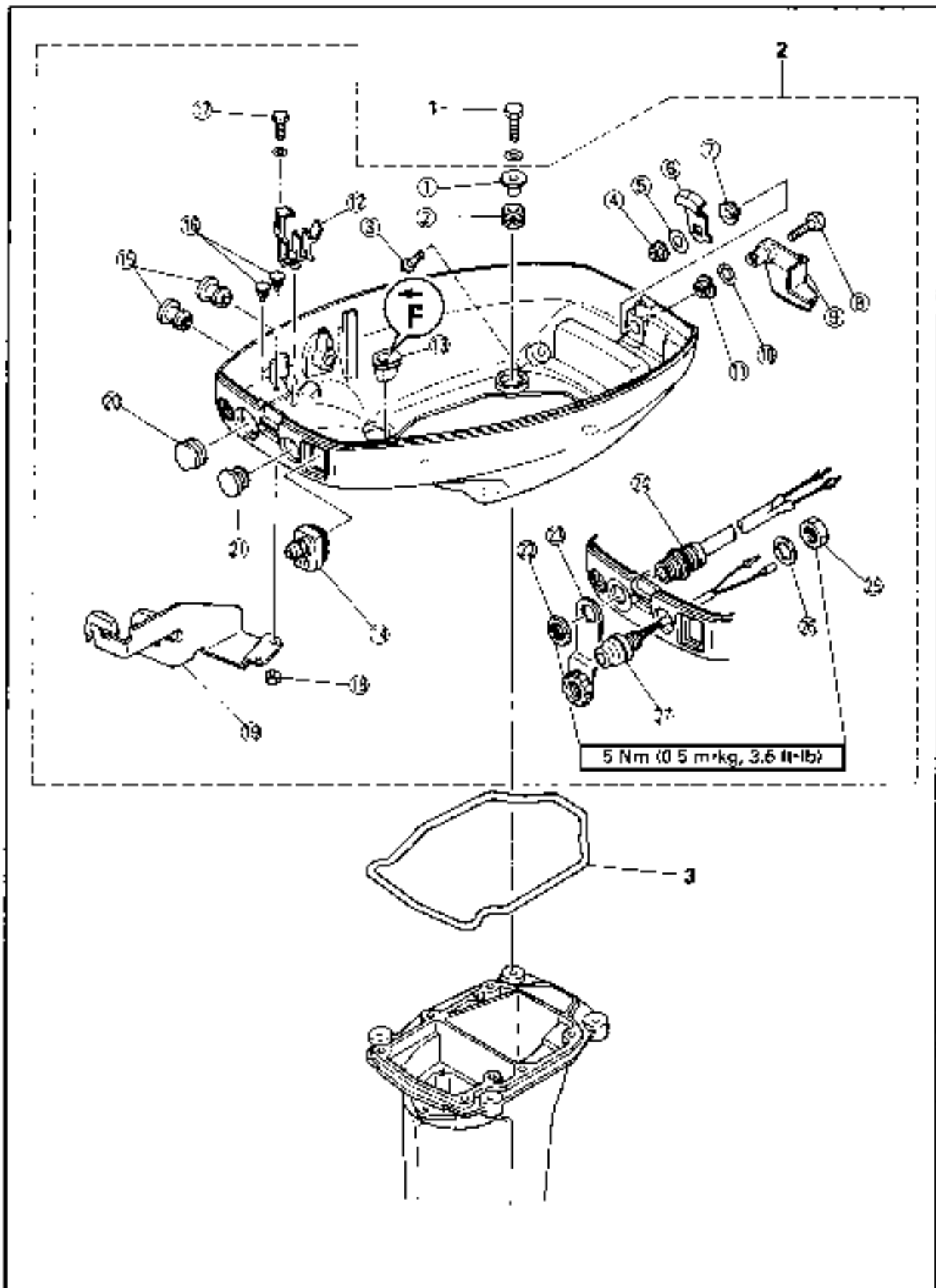



## REMOVAL AND INSTALLATION CHART

Step	Procedure/Part name	Q'ty	Service points
<b>BOTTOM COWLING REMOVAL</b>			Follow the left "Step" for removal. Refer to the "POWER UNIT REMOVAL" section in chapter 5. 6 x 25 mm
	Power unit		
1	Bolt (with washer)	4	
2	Bottom cowling assembly	1	
3	Seal rubber	1	
<b>BOTTOM COWLING DISASSEMBLY</b>			
①	Collar	4	
②	Grommet	4	
③	Hose nipple	1	
④	Nut	1	
⑤	Plane washer	1	
⑥	Clamp hook	1	
⑦	Bushing	1	
⑧	Bolt	1	6 x 25 mm
⑨	Clamp lever	1	
⑩	Wave washer	1	
⑪	Bushing	1	
⑫	Fitting plate	1	
⑬	Grommet	1	
⑭	Grommet	1	
⑮	Grommet	2	except for remote model
⑯	Grommet	2	
⑰	Bolt (with washer)	2	for remote model: 6 x 16 mm
⑱	Nut	2	
⑲	Remote bracket	1	
⑳	Grommet	1	except for electrical starter model
㉑	Grommet	1	
㉒	Nut	1	for 2P connector
㉓	Cap	1	
㉔	2P connector	1	
㉕	Nut	1	for starter switch model
㉖	Plane washer	1	
㉗	Starter switch	1	
			Reverse the removal steps for installation.



### UPPER CASE AND EXHAUST MANIFOLD EXPLODED DIAGRAM

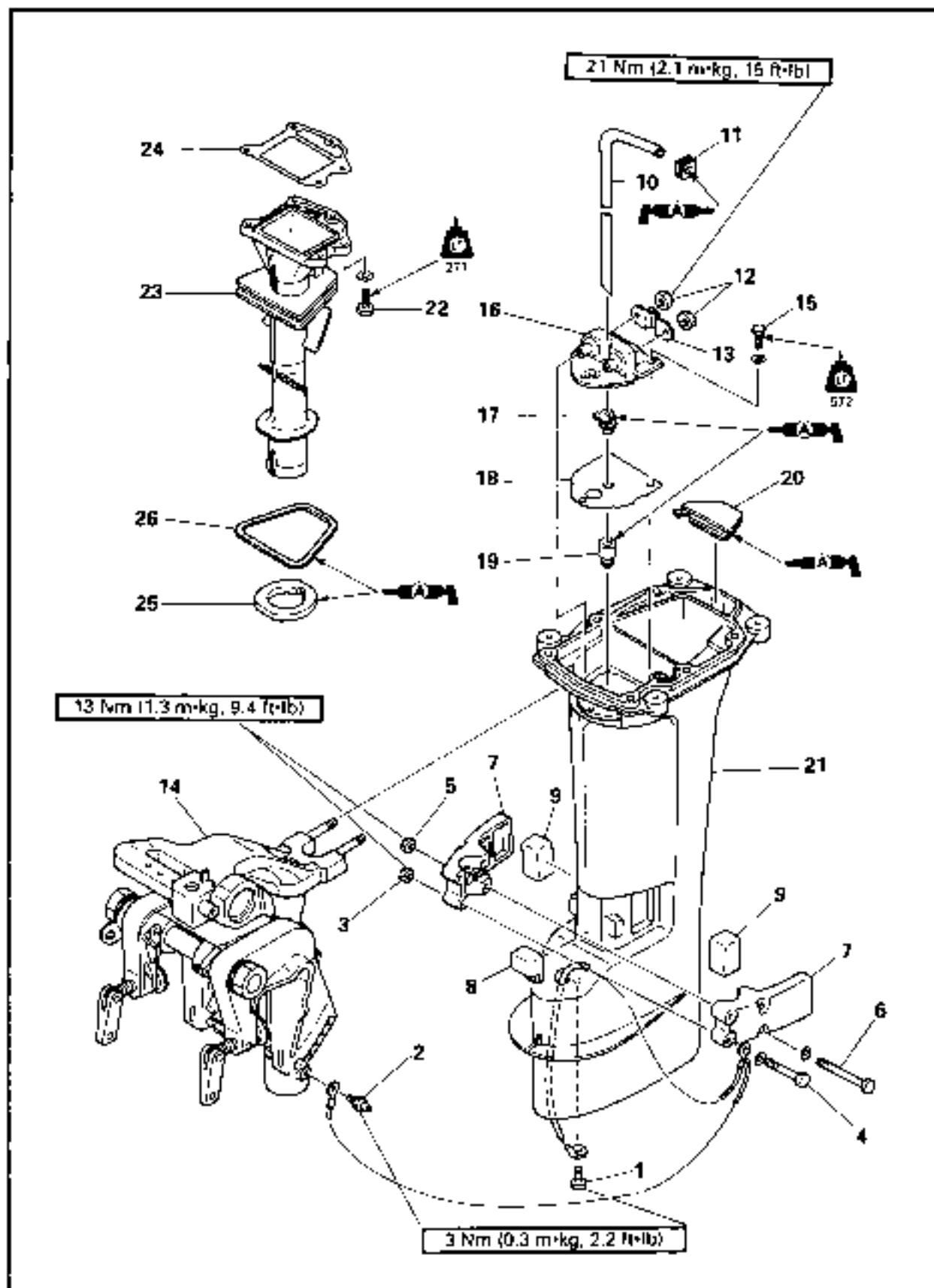



## REMOVAL AND INSTALLATION CHART

Step	Procedure/Part name	Qty	Service points
	<b>UPPER CASE REMOVAL</b>		Follow the left "Step" for removal.
	Bottom cowling assembly		Refer to the "BOTTOM COWLING REMOVAL" section.
	Lower unit		Refer to the "LOWER UNIT REMOVAL" section in chapter 6.
1	Screw	1	
2	Nipple	1	
3	Nut	2	
4	Bolt (with washer)	2	6 × 55 mm
5	Nut	2	
6	Bolt (with washer)	2	6 × 75 mm
7	Lower mount rubber housing	2	
8	Front mount rubber	1	
9	Side mount rubber	2	
10	Water tube	1	
11	Seal rubber	1	
12	Nut	2	
13	Plate	1	
14	Bracket unit assembly	1	
15	Bolt (with washer)	3	6 × 18 mm
16	Upper rubber mount	1	
17	Water rubber seal	1	
18	Upper casing gasket	1	
19	Water rubber seal	1	
20	Plane rubber	1	
21	Upper case	1	
	<b>EXHAUST MANIFOLD REMOVAL</b>		
	Power unit		Refer to the "POWER UNIT REMOVAL" section in chapter 5.
22	Bolt (with washer)	5	6 × 20 mm
23	Exhaust manifold	1	
24	Exhaust manifold gasket	1	
25	Exhaust manifold packing	1	
26	O-ring	1	
			Reverse the removal steps for installation.



**SERVICE POINTS****Rubber mount inspection**

1. Inspect:
  - Rubber mount  
Wear/Crack/Damage → Replace.

**Mount bolt inspection**

1. Inspect:
  - Mount bolt  
Wear/Bent/Damage → Replace.

BRKT



CLAMP BRACKET

**CLAMP BRACKET**  
**EXPLODED DIAGRAM**

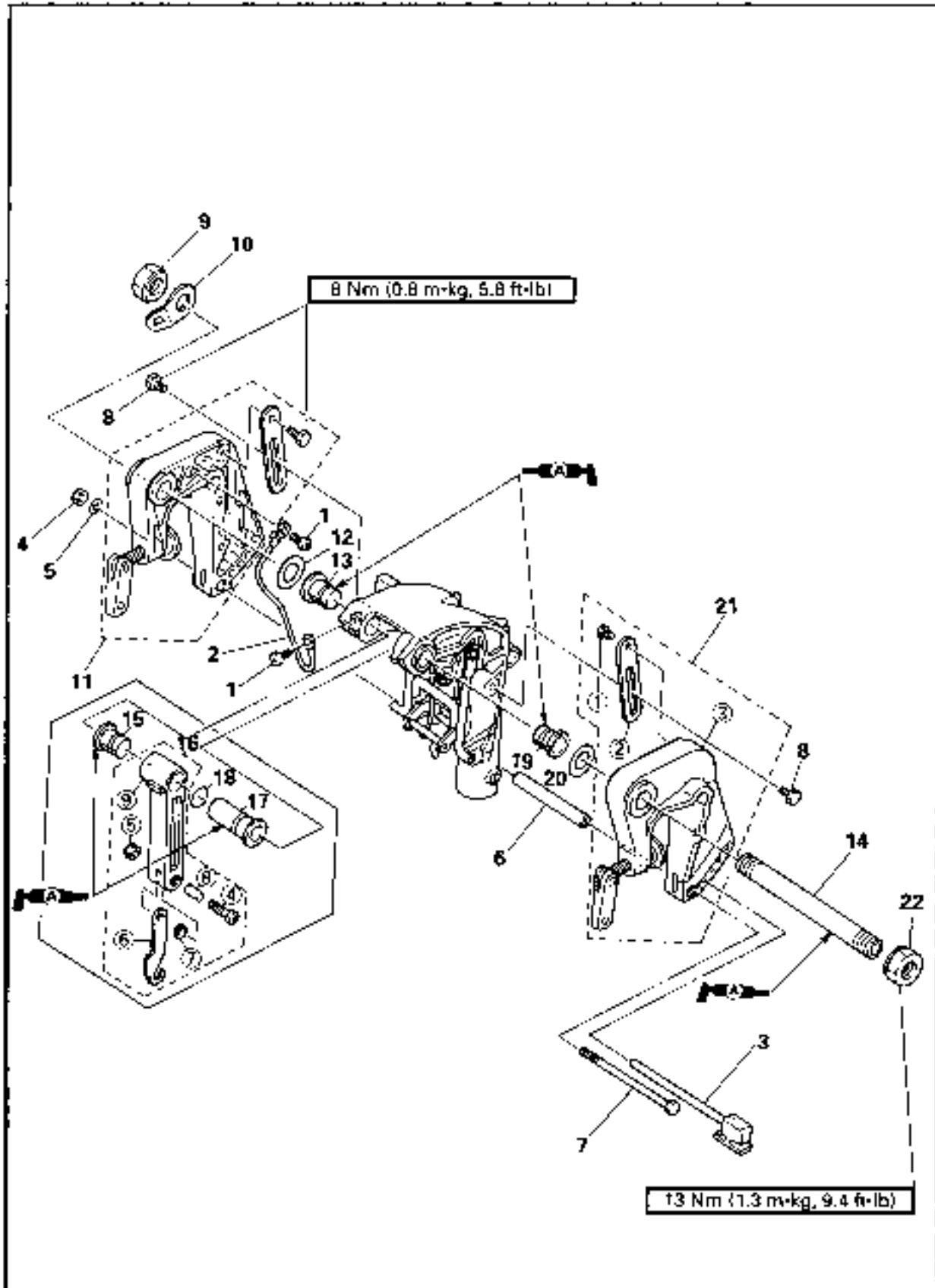



## REMOVAL AND INSTALLATION CHART

Step	Procedure/Part name	Qty	Service points
	<b>CLAMP BRACKET REMOVAL</b>		Follow the left "Step" for removal.
1	Screw	2	
2	Lead wire	1	
3	Tilt pin	1	
4	Nut	1	
5	Plane washer	1	
6	Collar	1	
7	Bolt	1	
8	Bolt	2	
9	Nut	1	
10	Clamp bracket plate	1	
11	Clamp bracket assembly 1	1	
12	Plane washer	1	
13	Bushing	1	
14	Clamp bracket bolt	1	
15	Bushing	1	Carrying handle model
16	Carrying handle assembly	1	
17	Bushing	1	
18	O-ring	1	
19	Bushing	1	
20	Plane washer	1	
21	Clamp bracket assembly 2	1	
22	Nut	1	
	<b>CLAMP BRACKET DISASSEMBLY</b>		
①	Bolt	2	
②	Tilt stop lever	2	
③	Clamp bracket	2	
	<b>CARRYING HANDLE DISASSEMBLY</b>		
④	Screw	1	Carrying handle model
⑤	Nut	1	
⑥	Hook	1	
⑦	Wave washer	1	
⑧	Collar	1	
⑨	Carrying handle	1	
			Reverse the removal steps for installation.



### STEERING AND SWIVEL BRACKET EXPLODED DIAGRAM

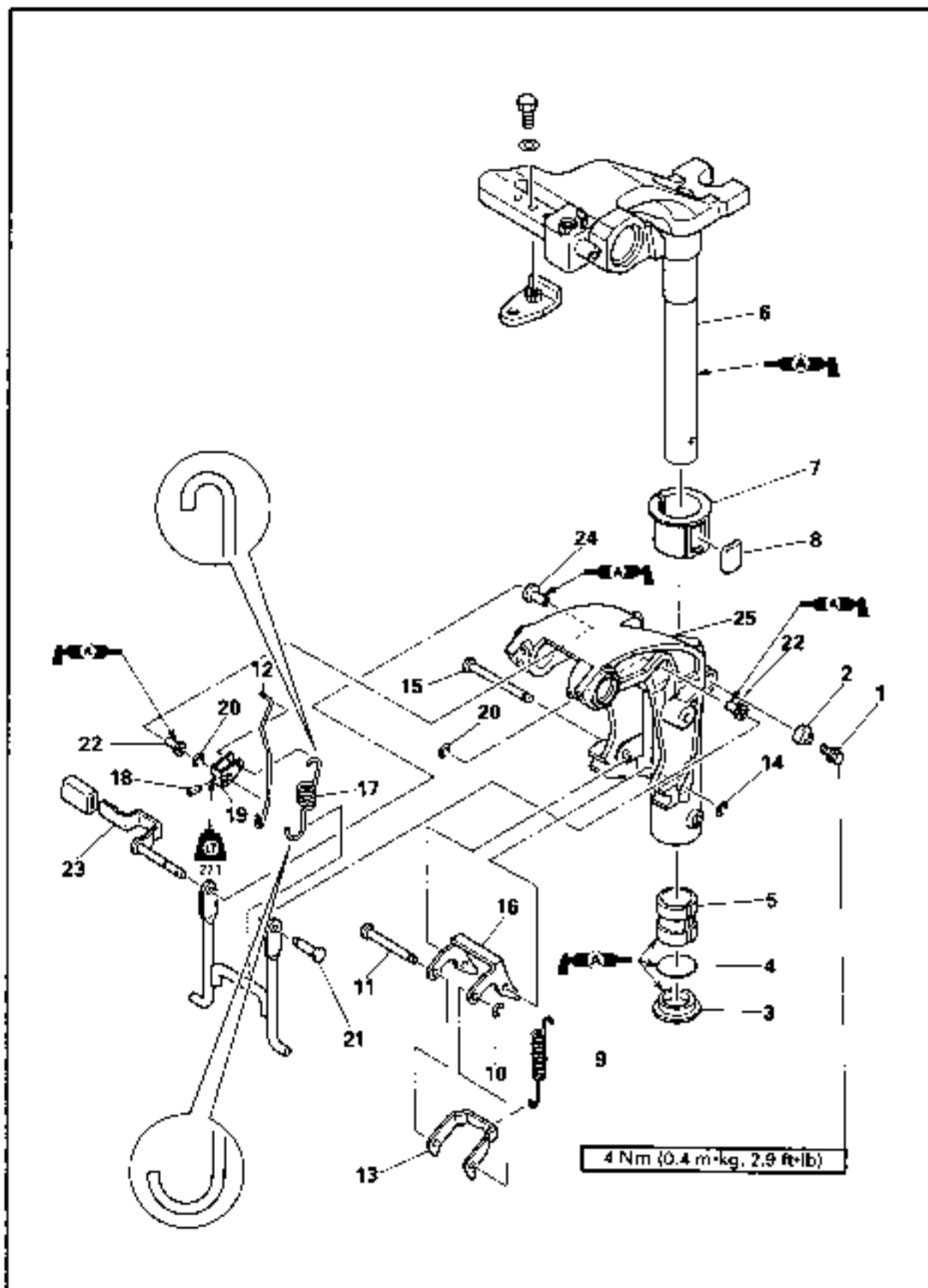



## REMOVAL AND INSTALLATION CHART

Step	Procedure/Part name	Q'ty	Service points
	<b>STEERING BRACKET REMOVAL</b>		Follow the left "Step" for removal.
	Clamp bracket assembly		Refer to the "BOTTOM COWLING" section.
1	Flange bolt	1	
2	Seal rubber	1	
3	Bushing	1	
4	O-ring	1	
5	Bushing	1	
6	Steering bracket	1	
7	Bushing	1	
8	Friction piece	1	
	<b>SWIVEL BRACKET DISASSEMBLY</b>		
9	Spring	1	
10	Clip	1	
11	Tilt lock shaft	1	
12	Tilt lock rod	1	
13	Tilt lock arm	1	
14	Clip	1	
15	Tilt lock plate shaft	1	
16	Shallow water drive lever	1	
17	Spring	1	
18	Pin	1	
19	Tilt lever	1	
20	Clip	2	
21	Shaft pin	1	
22	Bushing	2	
23	Control lever	1	
24	Bushing	1	
25	Swivel bracket	1	
			Reverse the removal steps for installation.



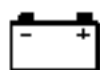

## CHAPTER 8 ELECTRICAL UNIT

<b>ELECTRICAL COMPONENTS</b> .....	8-1
MANUAL STARTER MODEL .....	8-1
ELECTRICAL STARTER MODEL .....	8-2
REMOTE CONTROL MODEL .....	8-3
<b>ELECTRICAL ANALYSIS</b> .....	8-4
INSPECTION .....	8-4
Peak voltage measurement .....	8-4
<b>IGNITION SYSTEM</b> .....	8-5
WIRING DIAGRAM .....	8-5
IGNITION SPARK GAP .....	8-6
CDI SYSTEM PEAK VOLTAGE .....	8-7
SPARK PLUG .....	8-8
SPARK PLUG CAP .....	8-9
ENGINE STOP SWITCH .....	8-10
MAIN SWITCH .....	8-10
<b>STARTING SYSTEM</b> .....	8-11
WIRING DIAGRAM .....	8-11
BATTERY .....	8-12
FUZE .....	8-12
WIRING HARNESS .....	8-12
WIRING CONNECTION .....	8-12
ENGINE STOP SWITCH .....	8-12
MAIN SWITCH .....	8-12
STARTER SWITCH .....	8-12
NEUTRAL SWITCH .....	8-12
STARTER RELAY .....	8-13
<b>STARTER MOTOR</b> .....	8-14
EXPLODED DIAGRAM .....	8-14
REMOVAL AND INSTALLATION CHART .....	8-15
SERVICE POINTS .....	8-15
Pinion removal .....	8-15
Pinion inspection .....	8-16
Armature inspection .....	8-16
Brush holder inspection .....	8-17
Cover inspection .....	8-17
<b>CHARGING SYSTEM</b> .....	8-18
WIRING DIAGRAM .....	8-18
CHARGING SYSTEM PEAK VOLTAGE .....	8-19
FUZE .....	8-19
BATTERY .....	8-19



## ELECTRICAL COMPONENTS MANUAL STARTER MODEL

- ① 2P connector\*
- ② Lighting coil
- ③ Charge coil
- ④ Ignition coil
- ⑤ CDI unit
- ⑥ Rectifier regulator\*
- ⑦ Engine stop switch

\*: Europe model

A To ⑤

B To ④, ③

C To pulser coil

D To ⑤

E To ①

B : Black

Br : Brown

B/O : Black/Orange

B/W : Black/White

G : Green

G/W : Green/White

L : Blue

W : White

W/R : White/Red

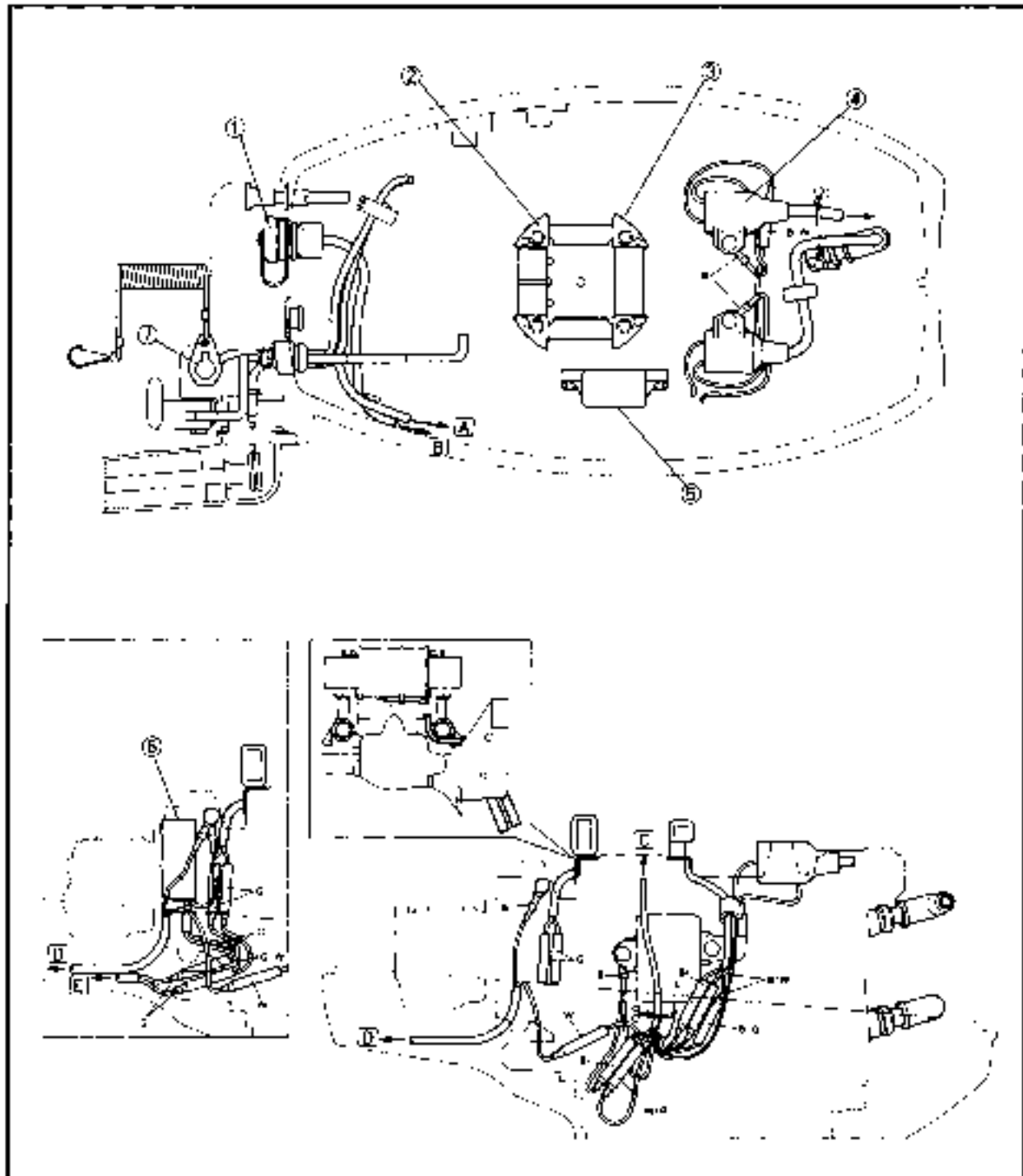





**ELECTRICAL STARTER MODEL**

- ① Battery cable
- ② Starter relay
- ③ Starter motor
- ④ Lighting coil
- ⑤ Charge coil
- ⑥ Ignition coil
- ⑦ CDI unit
- ⑧ Fuse
- ⑨ Neutral switch

- Ⓜ Rectifier
- Ⓝ Engine stop switch
- Ⓞ Starter switch
- A To Ⓜ
- B To Ⓞ
- C To battery
- D To Ⓞ
- E To Ⓞ
- F To Ⓞ
- G To Ⓞ
- H To spark plug

- P To ②, Ⓞ
- J To ②
- L To ②, Ⓞ
- K To Ⓞ
- L To pulse coil

- B : Black
- Br : Brown
- B/O : Black/Orange
- B/W : Black/White
- G : Green
- G/W : Green/White
- L : Blue
- R : Red
- W : White
- W/R : White/Red

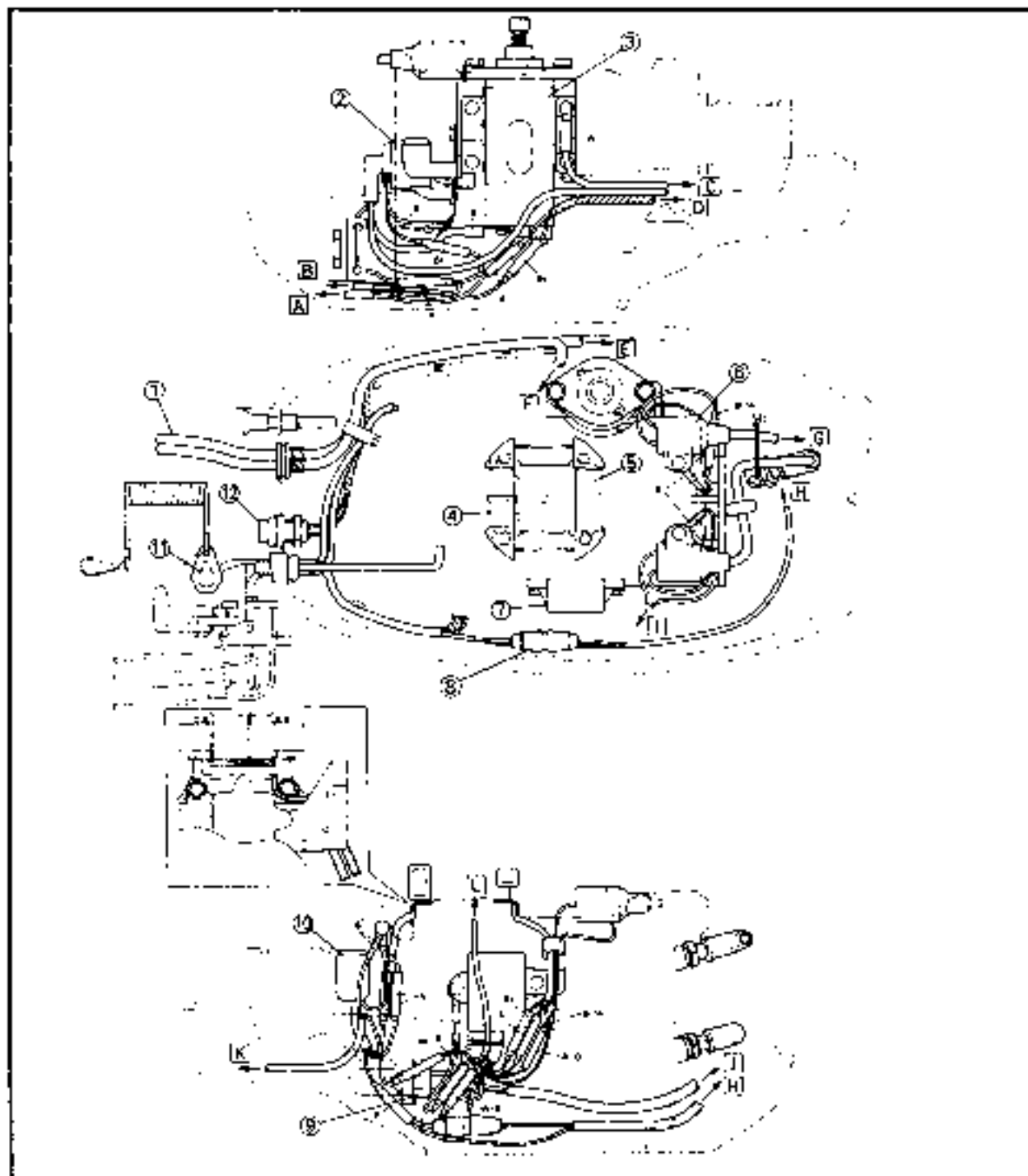

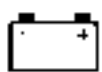

## REMOTE CONTROL MODEL

- ① Wire harness
- ② Battery cable
- ③ Starter relay
- ④ Starter motor
- ⑤ Lighting coil
- ⑥ Charge coil
- ⑦ Ignition coil
- ⑧ CDI unit

- ⑨ Fuse
- ⑩ Rectifier
- A To ①
- B To battery
- C To ②
- D To ④
- E To spark plug
- F To ⑧
- G To pulser coil

- B : Black
- Br : Brown
- B/O : Black/Orange
- B/W : Black/White
- G : Green
- GW : Green/White
- L : Blue
- R : Red
- W : White
- WR : White/Red

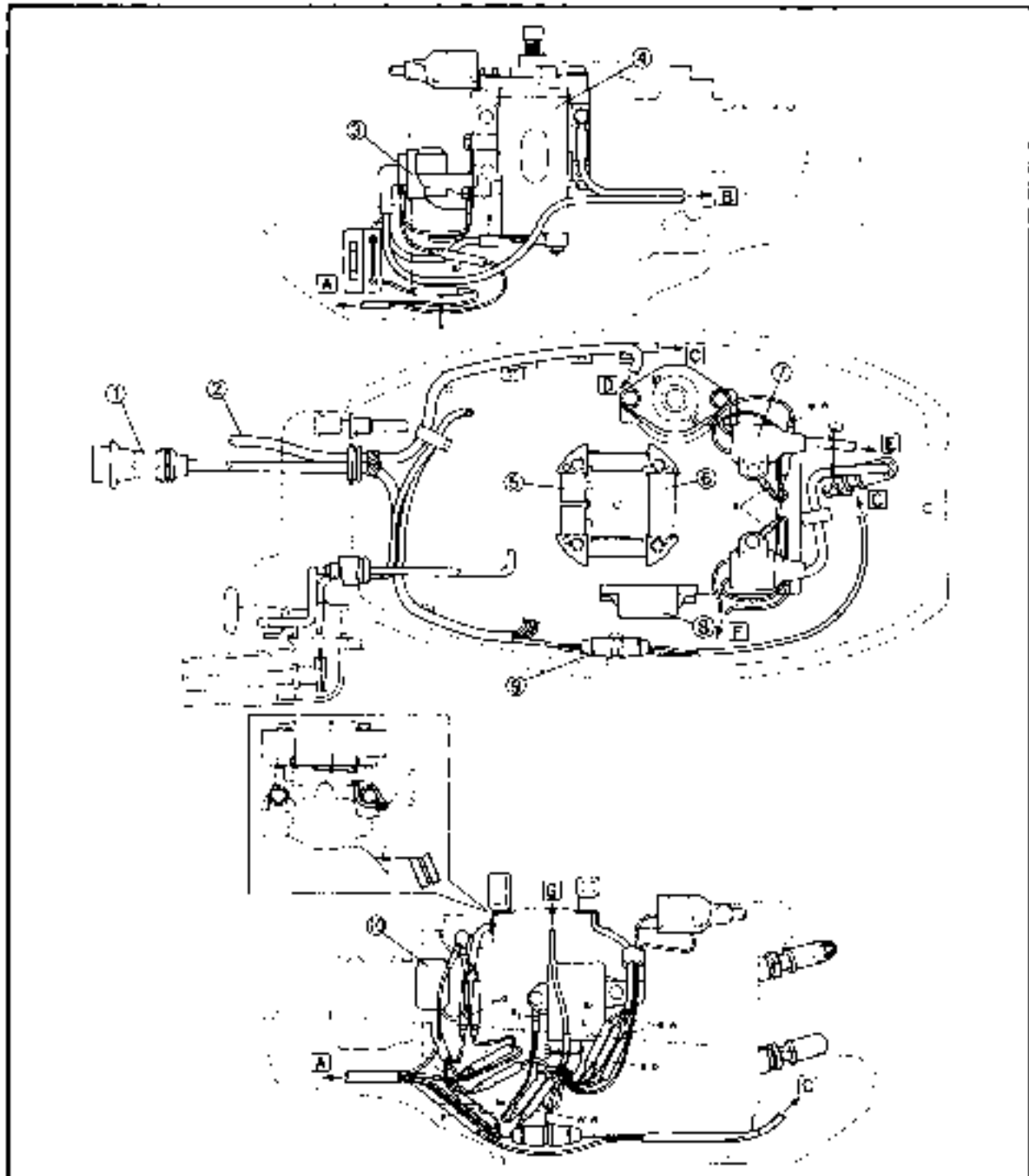



## ELECTRICAL ANALYSIS INSPECTION

**All measuring instruments should be handled with special care, or the correct measurement is impossible.**

**On an instrument powered by dry batteries, they should be checked for voltage periodically and replaced, if necessary.**

**NOTE:**

"○—○" indicates the terminals between which there is a continuity of electricity; i.e., a closed circuit at the respective switch position.

### Peak voltage measurement

**NOTE:**

- The coil output varies greatly cranking speed.
- Cranking the cold engine with the plugs in and a weak battery cannot be found proper readings.



**Digital tester:**

**J-39299**

**Peak volt adapter**

**YU-39991**

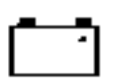

**IGNITION SYSTEM  
WIRING DIAGRAM**

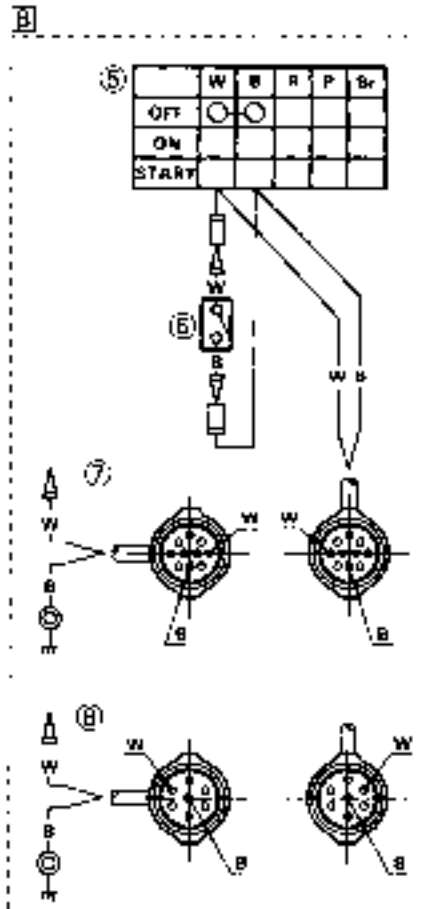
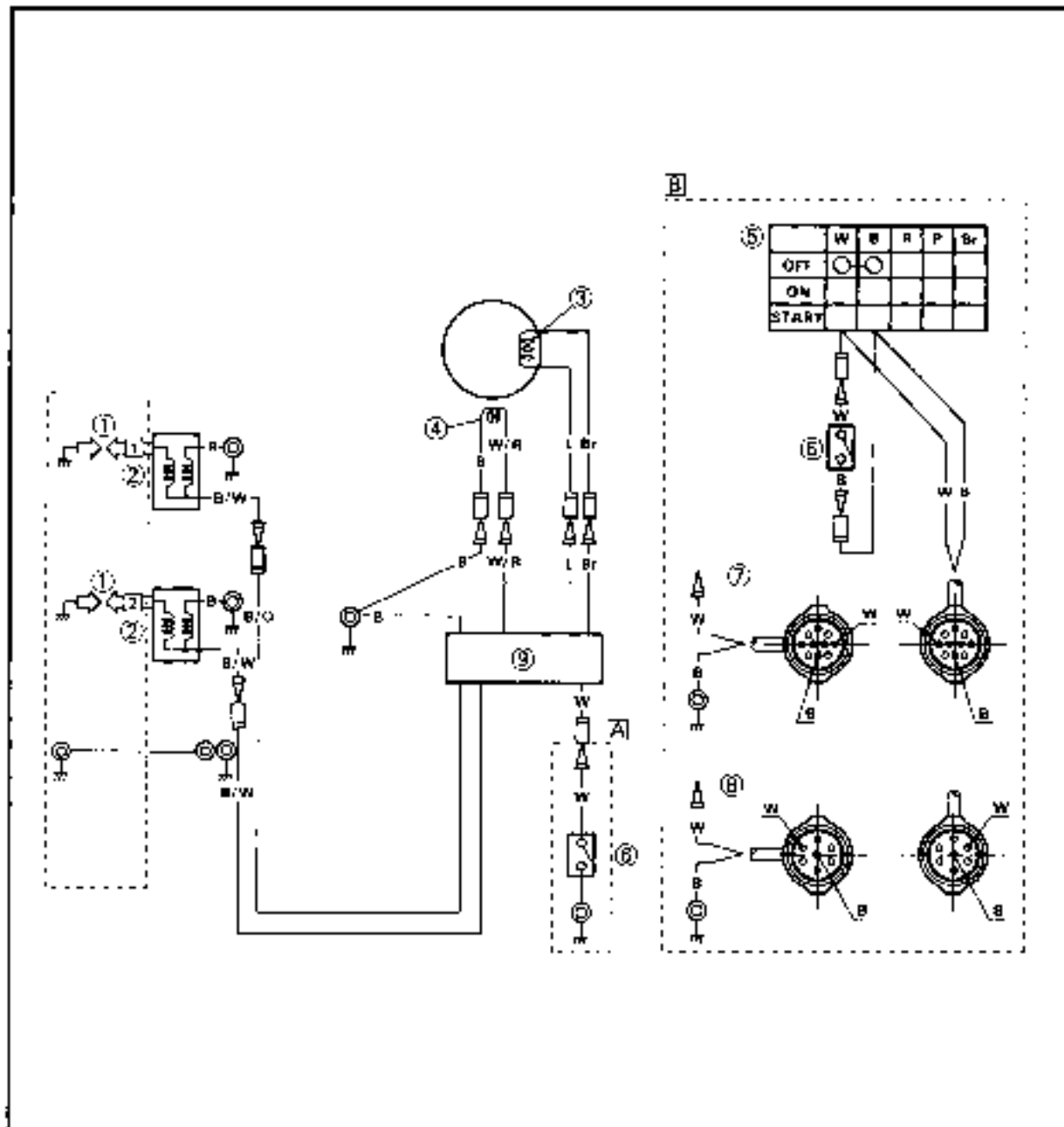

- ① Spark plug
- ② Ignition coil
- ③ Charge coil
- ④ Pulser coil
- ⑤ Main switch
- ⑥ Engine stop switch
- ⑦ 10P coupler
- ⑧ 7P coupler
- ⑨ CDI unit

- Br . Brown
- L . Blue
- W/R . White/Red
- B/O . Black/Orange
- B/W . Black/White
- W . White
- B . Black

[A] except for remote control model  
 [B] for remote control model

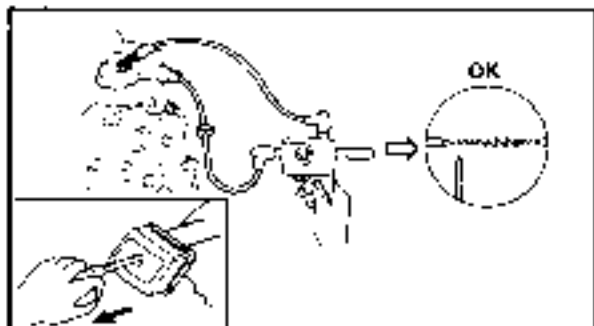
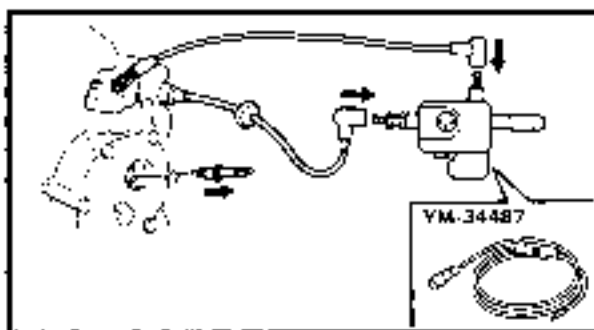
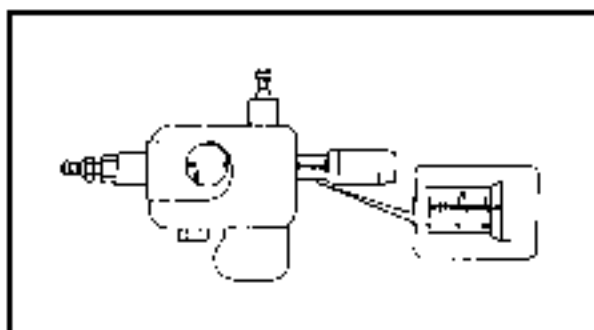
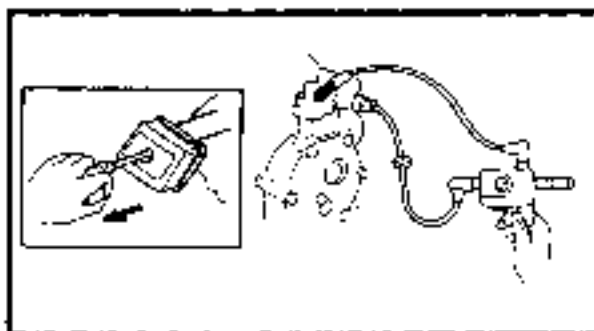
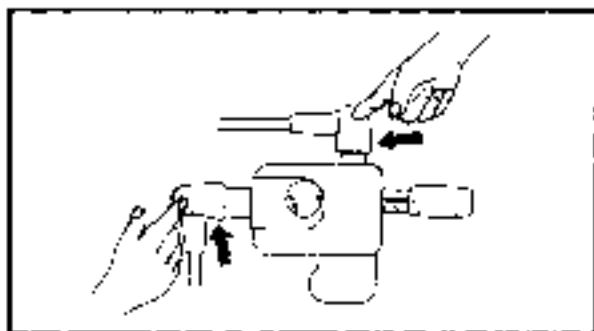

## IGNITION SPARK GAP

**⚠ WARNING**

- While taking spark check be careful not to touch any connection of lead wires of the "Ignition spark gap tester".
- When doing the spark test, take special care not to allow leakage from the removed plug cap.
- This check is likely to produce sparks, so be sure that no flammable gas or fluid is in the vicinity.

## 1. Check:

- Ignition spark gap  
Out of specification → Peak voltage measurement.



**Spark gap:**  
9 mm (0.35 in)

**Checking steps:**

- Adjust the spark gap to specification by turning the adjusting knob.



**Spark gap tester:**  
YM-34487/90690-06754

- Connect the spark-plug cap to the spark gap tester.
- Remove the spark plugs from the engine.
- Cranking the engine and check sparks of ignition system seen through discharge window

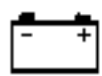

### CDI SYSTEM PEAK VOLTAGE

#### **WARNING**

While taking CDI unit check be careful not to touch any connection of lead wires.

#### **NOTE:**

- If there is no spark, or the spark is weak, continue with the CDI test.
- If a good spark is obtained, the problem is not with the CDI system, but possibly the spark plug or other component is defective.

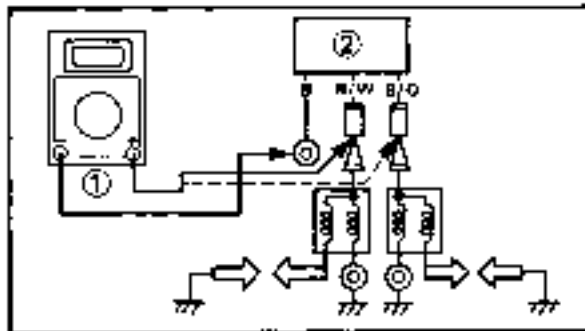

#### 1. Measure:

- CDI unit output (test #1)  
Below specification → Replace ignition coil.  
Repeat checking two times.



#### CDI output:

170 V at cranking  
215 V at 1500 r/min

#### Measurement steps:

- Connect the tester (1) to the CDI unit (2) as shown.
- Set the tester dial to specification.



#### Range:

$\bar{V}$

- Cranking or starting the engine.

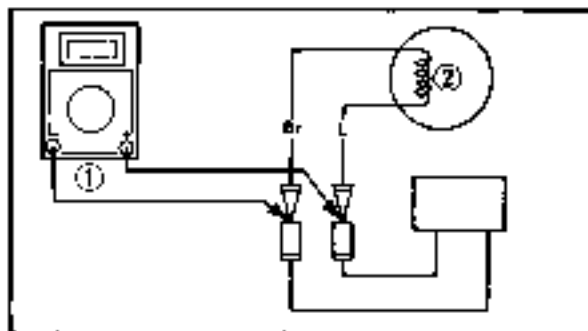
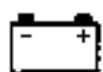

## 2. Measure:

- Charge coil output (test #2)  
Below specification → Replace charge coil.



**Charge coil output:**  
200 V at cranking  
250 V at 1500 r/min

**Measurement steps:**

- Connect the tester (1) to the charge coil (2) as shown.
- Set the tester dial to specification.



**Range:**



- Cranking or starting the engine.

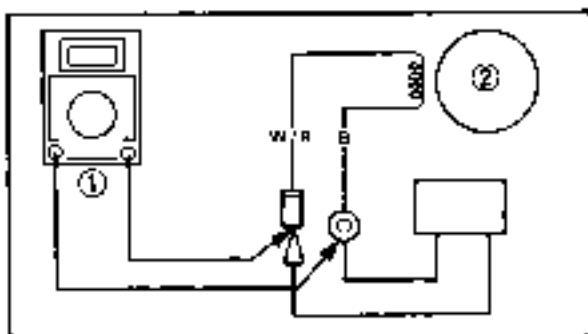

## 3. Measure:

- Pulser coil output (test #3)  
Beyond specification → Replace CDI unit.  
Below specification → Replace pulser coil.



**Pulser coil output:**  
5 V at cranking  
5 V at 1500 r/min

**Measurement steps:**

- Connect the tester (1) to the pulser coil (2) as shown.
- Set the tester dial to specification.



**Range:**



- Cranking or starting the engine.

**SPARK PLUG**

Refer to the "GENERAL" section in chapter 3.

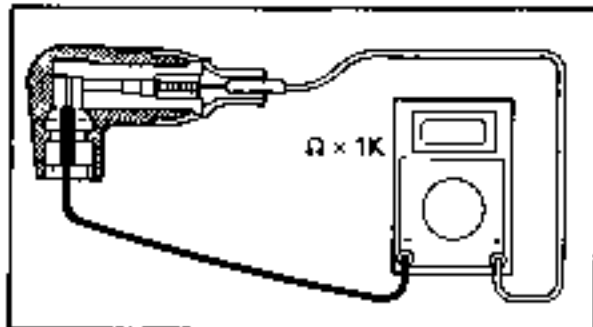
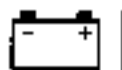
**SPARK PLUG CAP**1. *Inspect:*

- Spark plug cap  
Loosen → Tighten.  
Crack/Damage → Replace.

2. *Measure: (For Canada and Europe)*

- Spark plug cap resistance  
Out of specification → Replace

**Spark plug cap resistance:**

4.0 - 6.0 kΩ

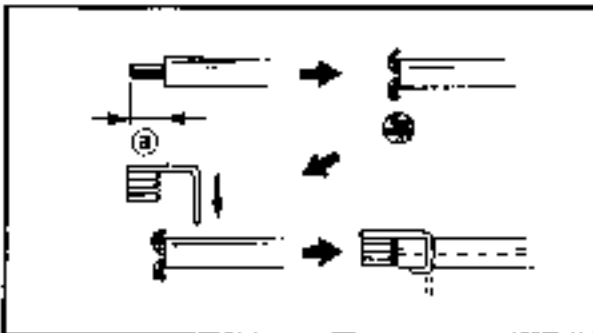
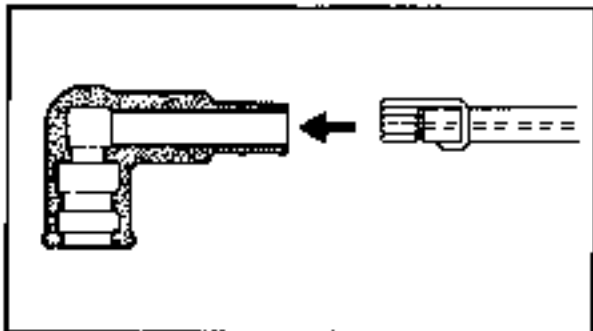
**Replacement steps: (Except for Canada and Europe)**

- Remove the spark-plug cap by pulling the spark-plug cap.
- Remove the plug-cap spring.
- Strip the insulation cover 5 mm (0.2 in) @, and spread the core wires outward.
- Fit the plug-cap spring close to the spread core wires and bend the spring end for clamping.
- Install the plug-cap spring into the spark-plug cap.

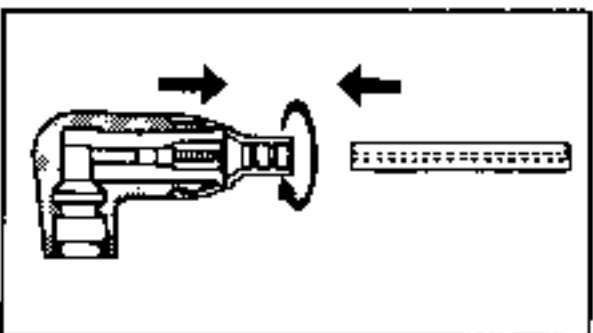
**Replacement steps: (For Canada and Europe)**

- Remove the spark-plug cap by turning the cap counterclockwise.
- Install the spark-plug cap by turning the cap clockwise until it stops.



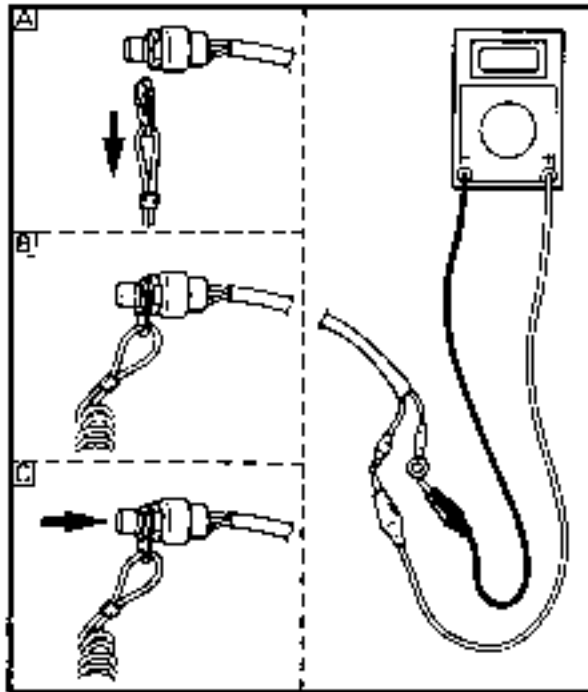

**ENGINE STOP SWITCH**

1. Check:
- Continuity
- Out of specification → Replace.

	Leads color	
	White	Black
Remove the lock-plate (A)	○	○
Install the lock-plate (B)		
Push the button (C)	○	○

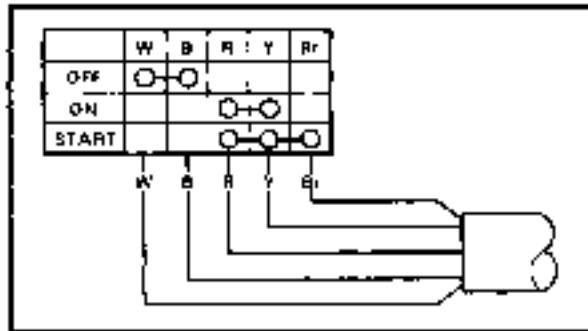

**MAIN SWITCH**

1. Check:
- Continuity
- Out of specification → Replace.

Switch position	Leads color				
	White	Black	Red	Yellow	Brown
OFF	○	○			
ON			○	○	
START			○	○	○



STARTING SYSTEM  
WIRING DIAGRAM

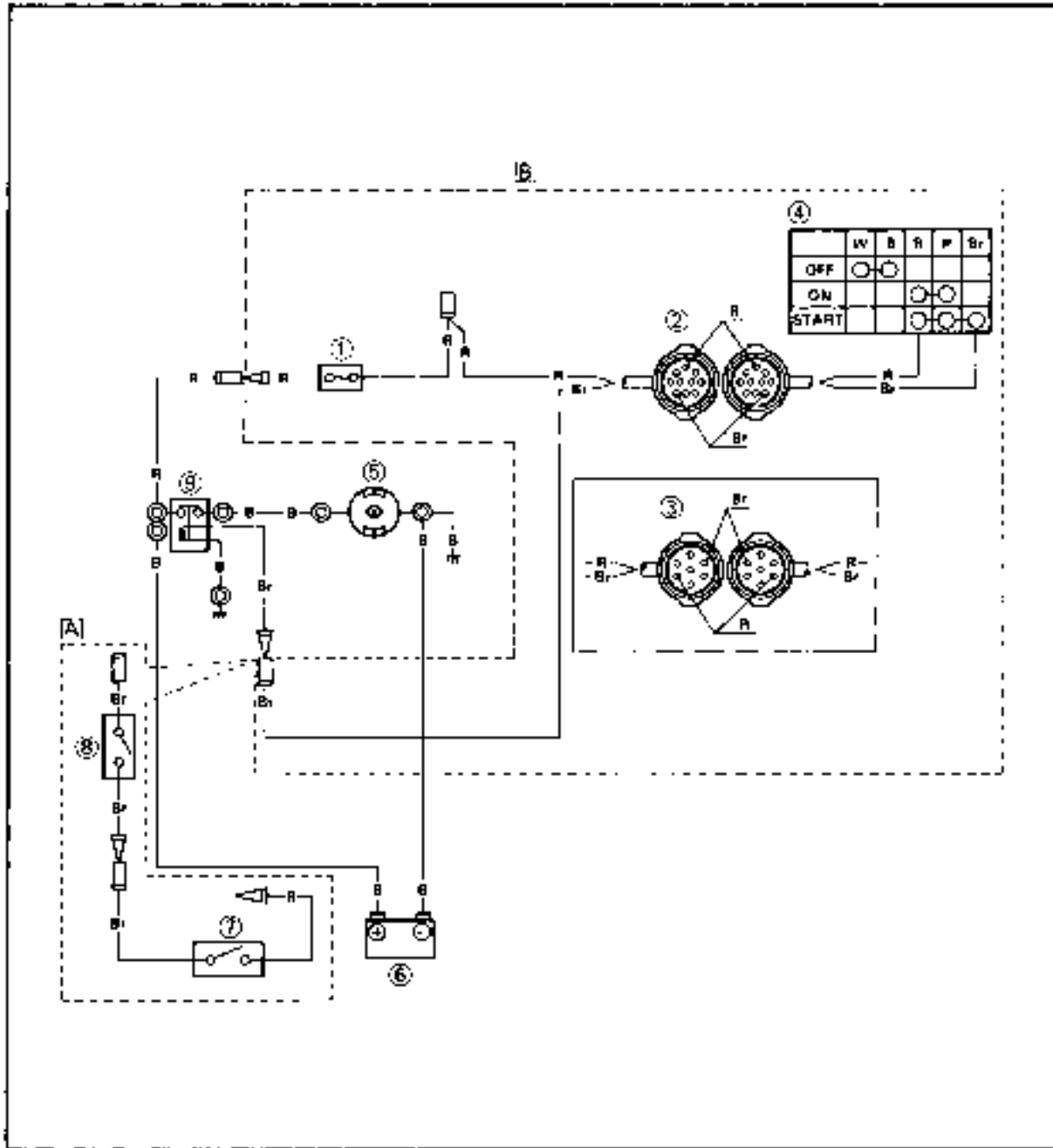

- ① Fuse
- ② 10P coupler
- ③ 7P coupler
- ④ Main switch
- ⑤ Starter motor
- ⑥ Battery
- ⑦ Starter switch
- ⑧ Neutral switch
- ⑨ Starter relay

- [A] Except for remote control model
- [B] Remote control model
- B : Black
- Br : Brown
- R : Red



**BATTERY**

Refer to the "GENERAL" section in chapter 3.

**FUSE**

1. Check:
  - Fuse Blown → Replace.

	<b>Fuse rating:</b> 12 V - 20 A
--	------------------------------------

**WIRING HARNESS**

1. Check:
  - Continuity Discontinuity → Replace.

**WIRING CONNECTION**

1. Check:
  - Wiring connection Poor connection → Correct

**ENGINE STOP SWITCH**

Refer to the "IGNITION SYSTEM" section.

**MAIN SWITCH**

Refer to the "IGNITION SYSTEM" section.

**STARTER SWITCH**

1. Check:
  - Continuity Out of specification → Replace.

	<b>Leads color</b>	
	<b>Red</b>	<b>Brown</b>
<b>Free</b>	○	○
<b>Push</b>	○	○

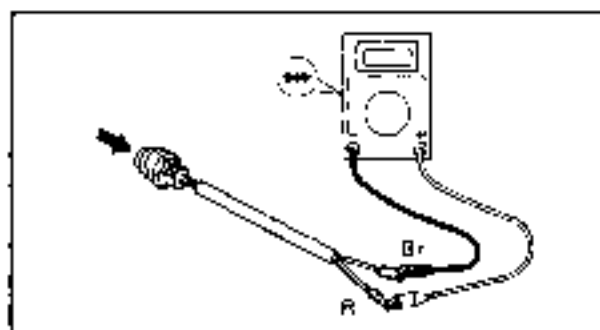

**NEUTRAL SWITCH**

1. Check:
  - Continuity Out of specification → Replace.

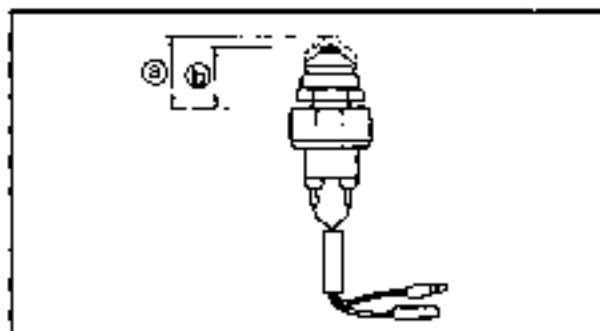

	<b>Length</b>	<b>Leads color</b>	
		<b>Brown</b>	<b>Brown</b>
<b>Free</b>	19.5 ~ 20.5 mm (0.77 ~ 0.81 in)		
(a) <b>Push</b>	18.5 ~ 19.5 mm (0.73 ~ 0.77 in)	○	○

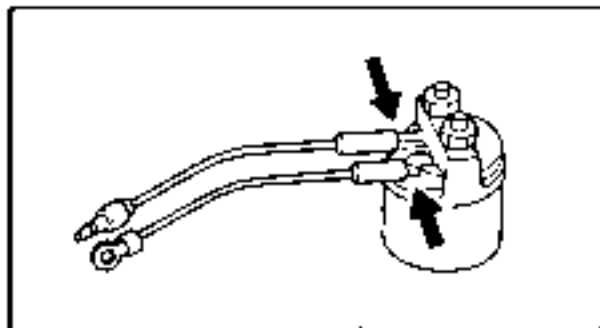
**STARTER RELAY**

## 1. Inspect:

- Brown lead terminal
  - Black lead terminal
- Loose → Tighten.

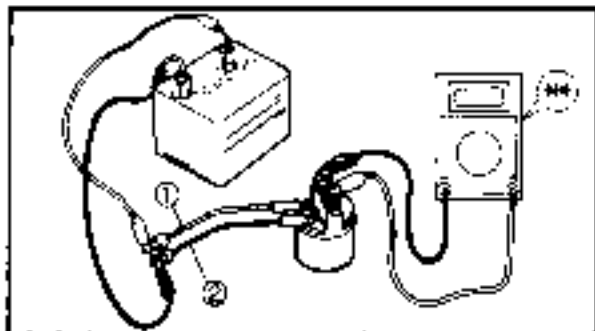

## 2. Check:

- Relay operation
- Does not function → Replace.

**Checking steps:**

- Connect the tester between the terminals of the starter relay as shown.
- Connect a 12 V battery.

**Brown lead ① → Positive terminal**

**Black lead ② → Negative terminal**

- Check that there is continuity between the starter relay terminals.



STARTER MOTOR  
EXPLODED DIAGRAM

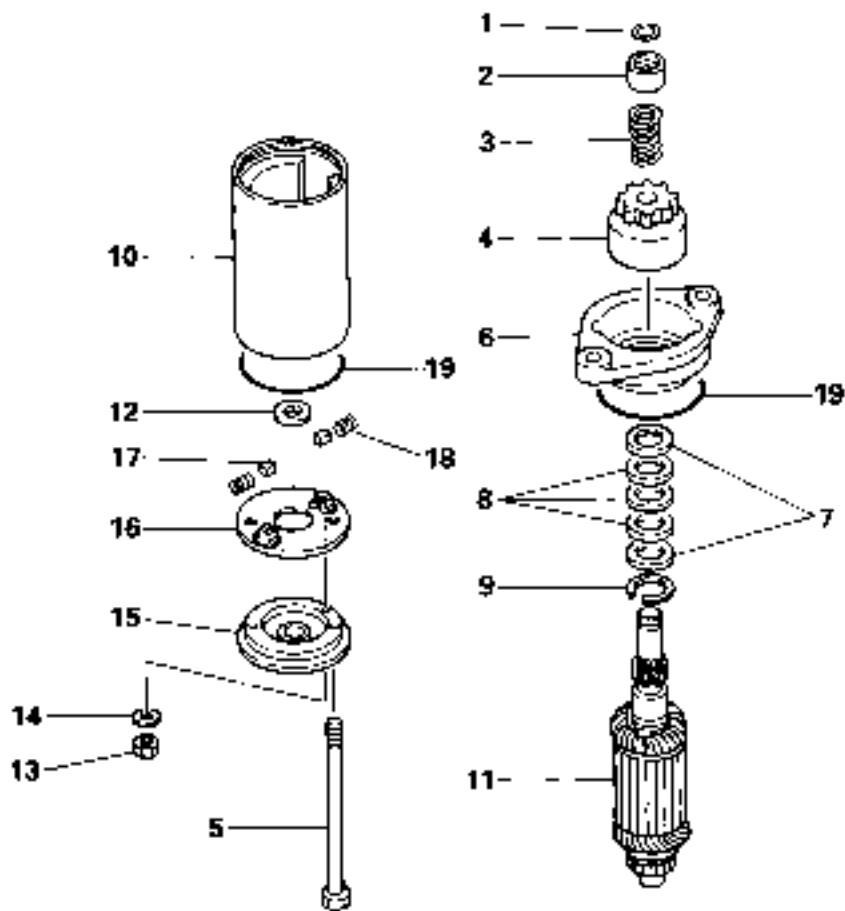



## REMOVAL AND INSTALLATION CHART

Step	Procedure/Part name	Qty	Service points	
	<b>STARTER MOTOR DISASSEMBLY</b>		Follow the left "Step" for removal. Refer to the "ELECTRICAL UNIT RE- MOVAL" section in chapter 5.	
	Starter motor assembly			
1	Clip	1		
2	Pinion stopper	1		
3	Spring	1		
4	Pinion	1		
5	Through bolt	2		
6	Front cover	1		
7	Washer	2		0.5 mm
8	Washer	3		0.25 mm
9	Circlip	1		
10	Starter assembly	1		
11	Armature assembly	1		
12	Washer	1		1.0 mm
13	Nut	1		
14	Spring washer	1		
15	Rear cover	1		
16	Brush holder	1		
17	Brush	1		
18	Spring	2		
19	O-ring	2		
			Reverse the removal steps for installation.	

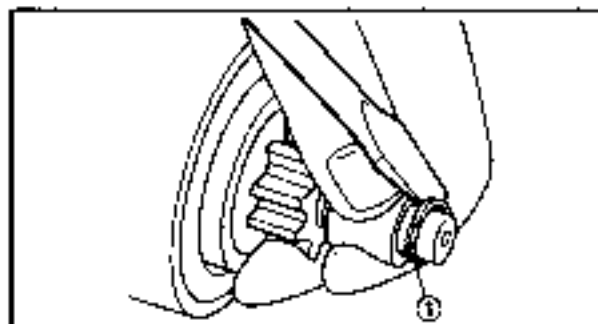
**SERVICE POINTS****Pinion removal**

- Remove:
  - Clip ①

**NOTE:**

Using a pry-bar, pry off the clip.

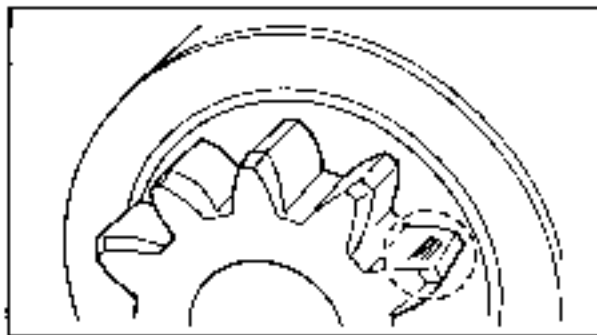
**Pinion inspection**

1. Inspect:
  - Pinion teeth  
Wear/Damage → Replace.

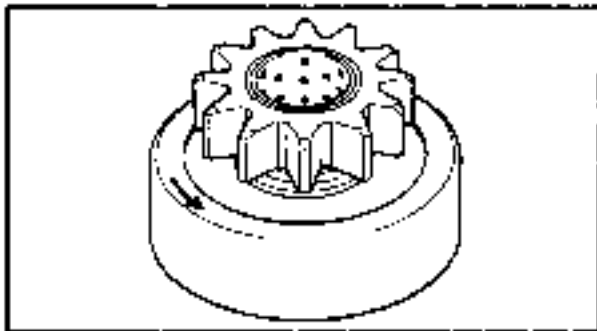

2. Check:
  - Clutch movement  
Damage → Replace.

**NOTE:**

Rotate the pinion clockwise, and check that it freely. Also try to rotate the pinion counterclockwise and confirm that it locks.

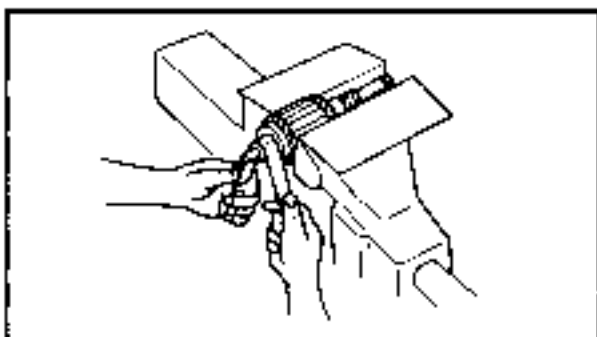
**Armature inspection**

1. Inspect:
  - Commutator  
Dirty → Clean with #600 abrasive paper.

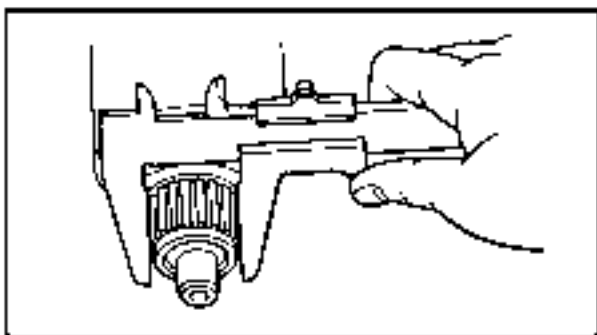

2. Measure:
  - Commutator diameter  
Out of specification → Replace.



**Commutator diameter:**  
Limit 19.4 mm (0.76 in)

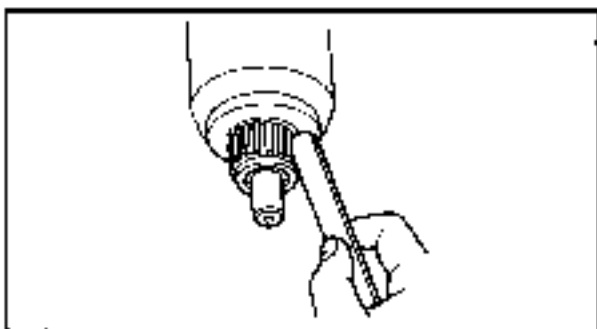

3. Check:
  - Commutator under cut  
Clog/Dirty → Clean.

**NOTE:**

Removal all particles metal by compressed air.

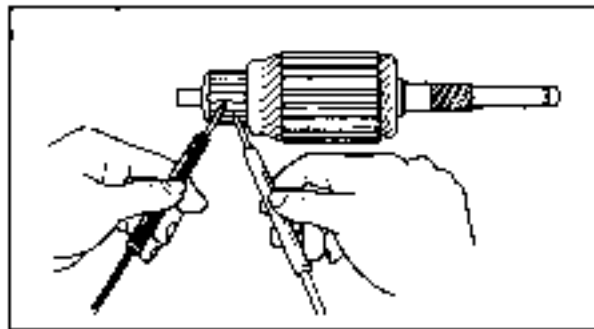

## 4. Inspect:

- Armature coil continuity  
Out of specification → Replace.

**Armature coil continuity:**

Commutator segments	Continuity
Segment - Laminations	Discontinuity
Segment - Shaft	Discontinuity

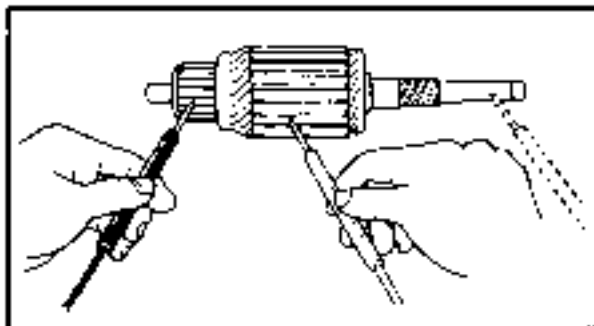
**Brush holder inspection**

## 1. Measure:

- Brush length <sup>a</sup>  
Out of specification → Replace.

**Brush length <sup>a</sup>:**

Limit 4.5 mm (0.18 in)

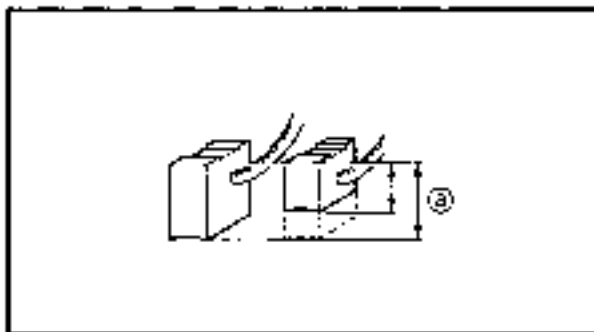

## 2. Check:

- Brush holder continuity  
Out of specification → Replace.

**Brush holder continuity.**

Brush holder ① - Base ②	Discontinuity
-------------------------	---------------

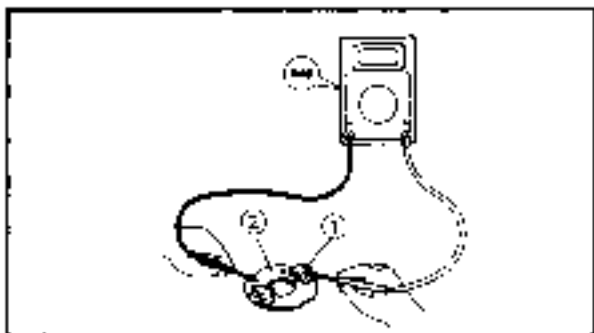
**Cover inspection**

## 1. Inspect

- Cover bushing  
Wear/Damage → Replace the cover





## CHARGING SYSTEM

## WIRING DIAGRAM

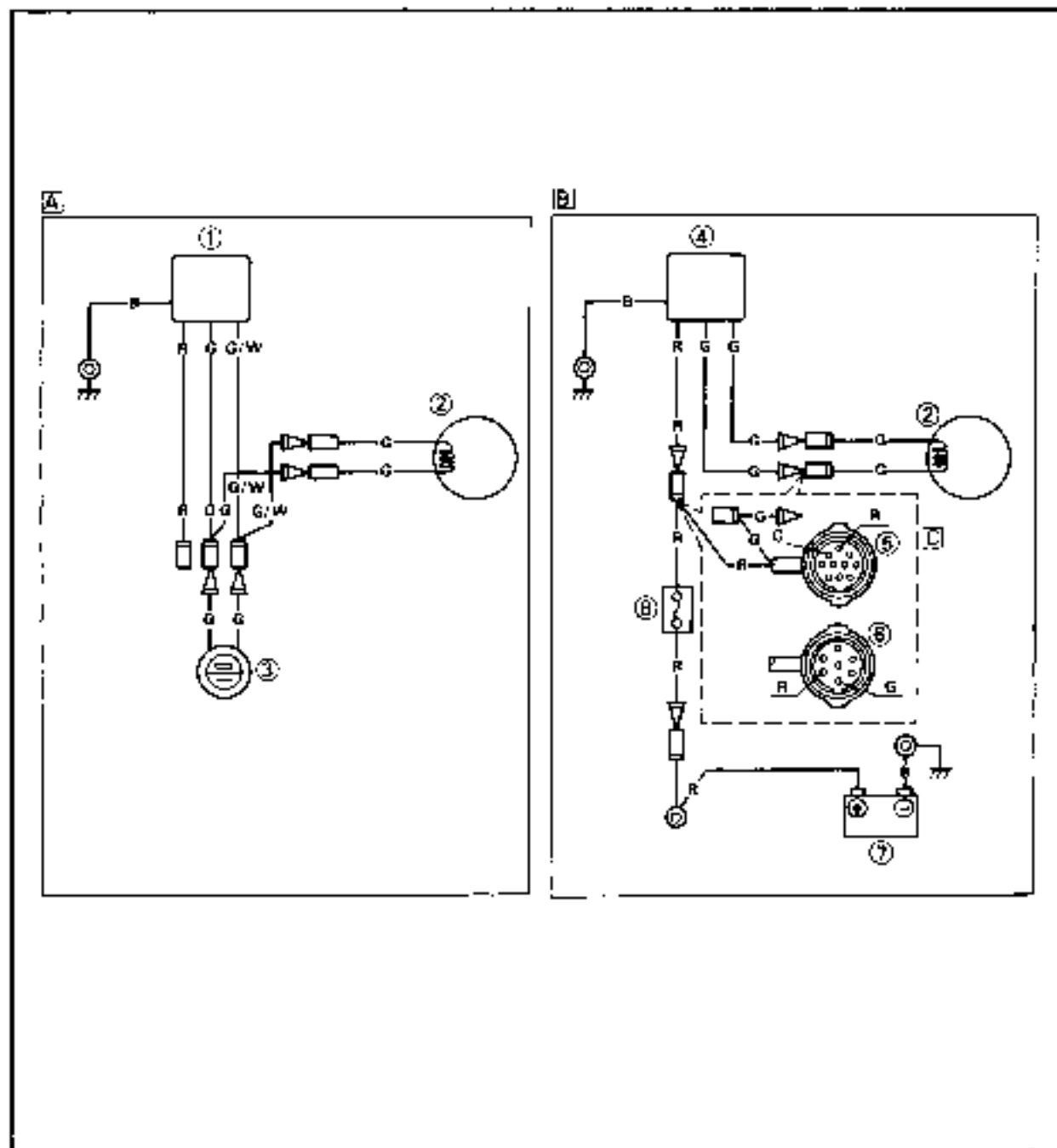

- ① Rectifier regulator
- ② Lighting coil
- ③ 2P connector
- ④ Rectifier
- ⑤ 10 P coupler
- ⑥ 7P coupler
- ⑦ Battery
- ⑧ Fuse

- A) for manual starter Europe model
- B) for electrical starter model
- C) for remote control model
- G : Green
- G/W: Green/White
- R : Red
- B : Black

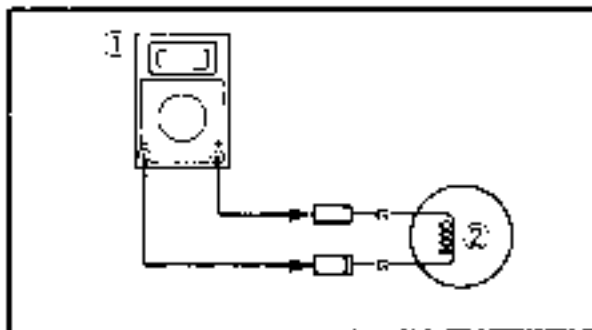
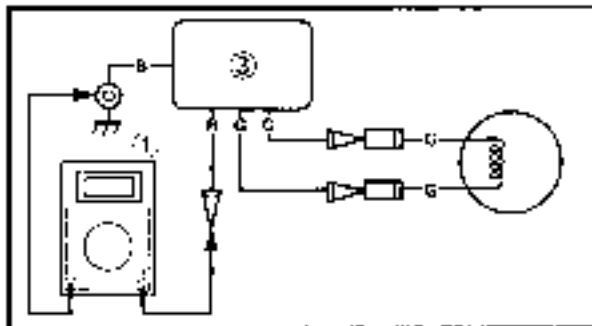
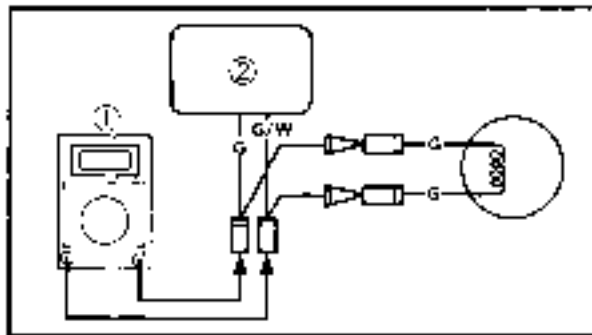
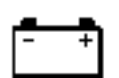

### CHARGING SYSTEM PEAK VOLTAGE

#### 1 Measure:

- Rectifier output  
Below specification → Lighting coil measurement.



#### Rectifier regulator output:

{2P connector model}

11 V at cranking

13 V at 1500 r/min

#### Rectifier output: (electrical model)

11 V at cranking

13 V at 1500 r/min

#### Measurement steps:

- Connect the tester (1) to the rectifier regulator (2) / rectifier (3) as shown
- Set the tester dial to specification.



#### Range:

V

- Cranking or starting the engine.

#### 2 Measure:

- Lighting coil output  
Beyond specification → Replace rectifier regulator/rectifier.  
Below specification → Replace lighting coil.



#### Lighting coil output:

12 V at 1500 r/min

#### Measurement steps:

- Connect the tester (1) to the lighting coil (2) as shown.
- Set the tester dial to specification.



#### Range:

V

- Starting the engine.

### FUSE

Refer to the "STARTING SYSTEM" section.

### BATTERY

Refer to the "GENERAL" section in chapter 3.

---

## CHAPTER 9 TROUBLE ANALYSIS

TROUBLE ANALYSIS .....	9-1
TROUBLE ANALYSIS CHART .....	9-1

### TROUBLE ANALYSIS

**NOTE:**

Following items should be obtained before "trouble analysis".

1. Battery is charged and its specified gravity is in specification.
2. There is no incorrect wiring connection.
3. Wiring connections are surely engaged and without any rust.
4. Lanyard is installed to the engine stop switch.
5. Shift position is in neutral
6. Fuel is coming to the carburetor.
7. Correct rigging and engine setting are obtained.
8. Engine is free from any "Hull problem".

### TROUBLE ANALYSIS CHART

Trouble mode										Check elements		
ENGINE WILL NOT START	ROUGH IDLING	ENGINE STALLS	ENGINE WILL NOT STOP	POOR PERFORMANCE	OVERHEATING	LOOSE STEERING	HARD SHIFTING	POOR BATTERY CHARGING			Relative part	Reference Chapter
<b>FUEL SYSTEM</b>												
<input type="checkbox"/>		<input type="checkbox"/>		<input type="checkbox"/>							Fuel hose	4
<input type="checkbox"/>		<input type="checkbox"/>		<input type="checkbox"/>							Fuel joint	4
<input type="checkbox"/>	<input type="checkbox"/>	<input type="checkbox"/>		<input type="checkbox"/>							Fuel filter	4
<input type="checkbox"/>		<input type="checkbox"/>		<input type="checkbox"/>							Fuel pump	4
<input type="checkbox"/>	<input type="checkbox"/>	<input type="checkbox"/>		<input type="checkbox"/>							Carburetor	4
		<input type="checkbox"/>		<input type="checkbox"/>	<input type="checkbox"/>						Pilot screw setting	4
		<input type="checkbox"/>		<input type="checkbox"/>							Idle speed	3
<b>POWER UNIT</b>												
<input type="checkbox"/>	<input type="checkbox"/>			<input type="checkbox"/>							Compression	5
<input type="checkbox"/>	<input type="checkbox"/>			<input type="checkbox"/>							Reed valve	5
<input type="checkbox"/>	<input type="checkbox"/>										Cylinder head gasket	5
<input type="checkbox"/>				<input type="checkbox"/>							Seal	5
<input type="checkbox"/>				<input type="checkbox"/>							Cylinder body	5
<input type="checkbox"/>				<input type="checkbox"/>							Piston ring	5
<input type="checkbox"/>				<input type="checkbox"/>							Crank case	5
<input type="checkbox"/>				<input type="checkbox"/>							Piston	5
	<input type="checkbox"/>			<input type="checkbox"/>							Control unit adjustment	3
				<input type="checkbox"/>							Bearing	5
					<input type="checkbox"/>						Thermostat	5
					<input type="checkbox"/>						Water passage	5

Trouble mode										Check elements		
ENGINE WILL NOT START	ROUGH IDLING	ENGINE STALLS	ENGINE WILL NOT STOP	POOR PERFORMANCE	OVERHEATING	LOOSE STEERING	HARD SHIFTING	POOR BATTERY CHARGING			Relative part	Reference Chapter
<b>LOWER UNIT</b>												
<input type="checkbox"/>							<input type="checkbox"/>				Neutral position	6
<input type="checkbox"/>							<input type="checkbox"/>				Clutch	6
<input type="checkbox"/>							<input type="checkbox"/>				Gear	6
				<input type="checkbox"/>	<input type="checkbox"/>						Water inlet	6
				<input type="checkbox"/>	<input type="checkbox"/>						Water pump	6
				<input type="checkbox"/>							Propeller shaft	6
							<input type="checkbox"/>				Shifter/Pin	6
							<input type="checkbox"/>				Shift cam	6
							<input type="checkbox"/>				Shift rod	6
							<input type="checkbox"/>				Lower case	6
<b>BRACKET UNIT</b>												
						<input type="checkbox"/>					Bracket	7
						<input type="checkbox"/>					Mount rubber	7
<b>ELECTRICAL</b>												
<input type="checkbox"/>	<input type="checkbox"/>	<input type="checkbox"/>		<input type="checkbox"/>	<input type="checkbox"/>						Ignition system	8
<input type="checkbox"/>			<input type="checkbox"/>								Starting system	8
								<input type="checkbox"/>			Charging system	8











**YAMAHA**  
YAMAHA MOTOR CO., LTD  
Printed in USA