

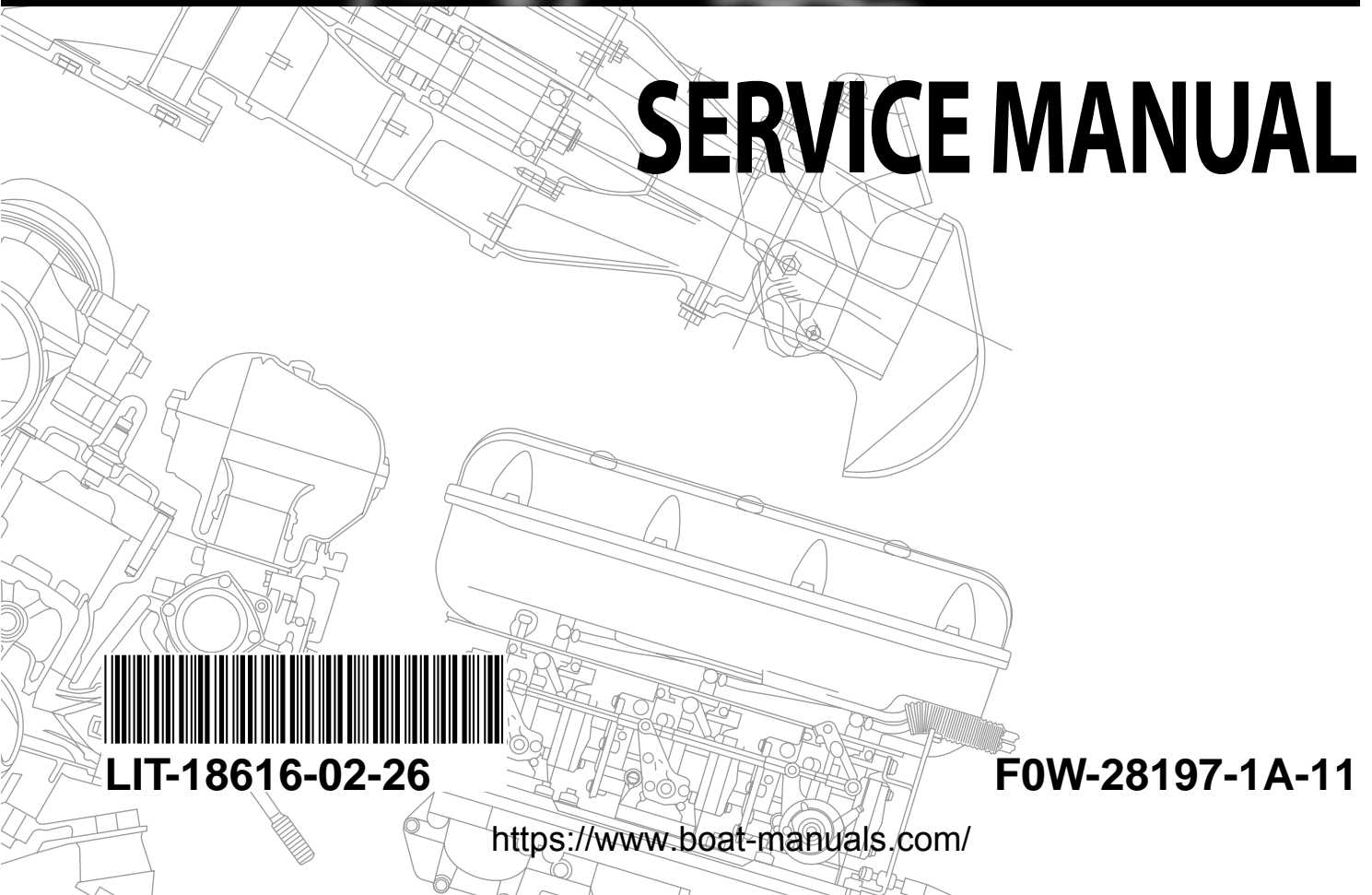

WaveRunner GP800R



SERVICE MANUAL



LIT-18616-02-26

F0W-28197-1A-11

<https://www.boat-manuals.com/>

NOTICE

This manual has been prepared by Yamaha primarily for use by Yamaha dealers and their trained mechanics when performing maintenance procedures and repairs to Yamaha equipment. It has been written to suit the needs of persons who have a basic understanding of the mechanical and electrical concepts and procedures inherent in the work, for without such knowledge attempted repairs or service to the equipment could render it unsafe or unfit for use.

Because Yamaha has a policy of continuously improving its products, models may differ in detail from the descriptions and illustrations given in this publication. Use only the latest edition of this manual. Authorized Yamaha dealers are notified periodically of modifications and significant changes in specifications and procedures, and these are incorporated in successive editions of this manual.

A10001-0*

**WaveRunner GP800R
SERVICE MANUAL
©2000 by Yamaha Motor Corporation, USA
1st Edition, November 2000
All rights reserved.
Any reprinting or unauthorized use
without the written permission of
Yamaha Motor Corporation, USA
is expressly prohibited.
Printed in USA
LIT-18616-02-26**

HOW TO USE THIS MANUAL

MANUAL FORMAT

All of the procedures in this manual are organized in a sequential, step-by-step format. The information has been compiled to provide the mechanic with an easy to read, handy reference that contains comprehensive explanations of all disassembly, repair, assembly, and inspection operations.

In this revised format, the condition of a faulty component will precede an arrow symbol and the course of action required will follow the symbol, e.g.,

- Bearings
Pitting/scratches → Replace.

To assist you in finding your way through this manual, the section title and major heading is given at the top of every page.

ILLUSTRATIONS

The illustrations within this service manual represent all of the designated models.

CROSS REFERENCES

The cross references have been kept to a minimum. Cross references will direct you to the appropriate section or chapter.

IMPORTANT INFORMATION

In this Service Manual particularly important information is distinguished in the following ways.

 The Safety Alert Symbol means ATTENTION! BECOME ALERT! YOUR SAFETY IS INVOLVED!

WARNING

Failure to follow **WARNING** instructions could result in severe injury or death to the machine operator, a bystander, or a person inspecting or repairing the watercraft.

CAUTION:

A **CAUTION** indicates special precautions that must be taken to avoid damage to the watercraft.

NOTE:

A **NOTE** provides key information to make procedures easier or clearer.

IMPORTANT:

This part has been subjected to change of specification during production.

HOW TO USE THIS MANUAL

- ① To help identify parts and clarify procedure steps, there are exploded diagrams at the start of each removal and disassembly section.
- ② Numbers are given in the order of the jobs in the exploded diagram.
- ③ Symbols indicate parts to be lubricated or replaced (see "SYMBOLS").
- ④ A job instruction chart accompanies the exploded diagram, providing the order of jobs, names of parts, notes in jobs, etc.
- ⑤ Dimension figures and the number of parts, are provided for fasteners that require a tightening torque.

Example:

Bolt or screw size 10 × 25 mm : M10 (D) × 25 mm (L)

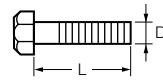

- ⑥ Jobs requiring more information (such as special tools and technical data) are described sequentially.

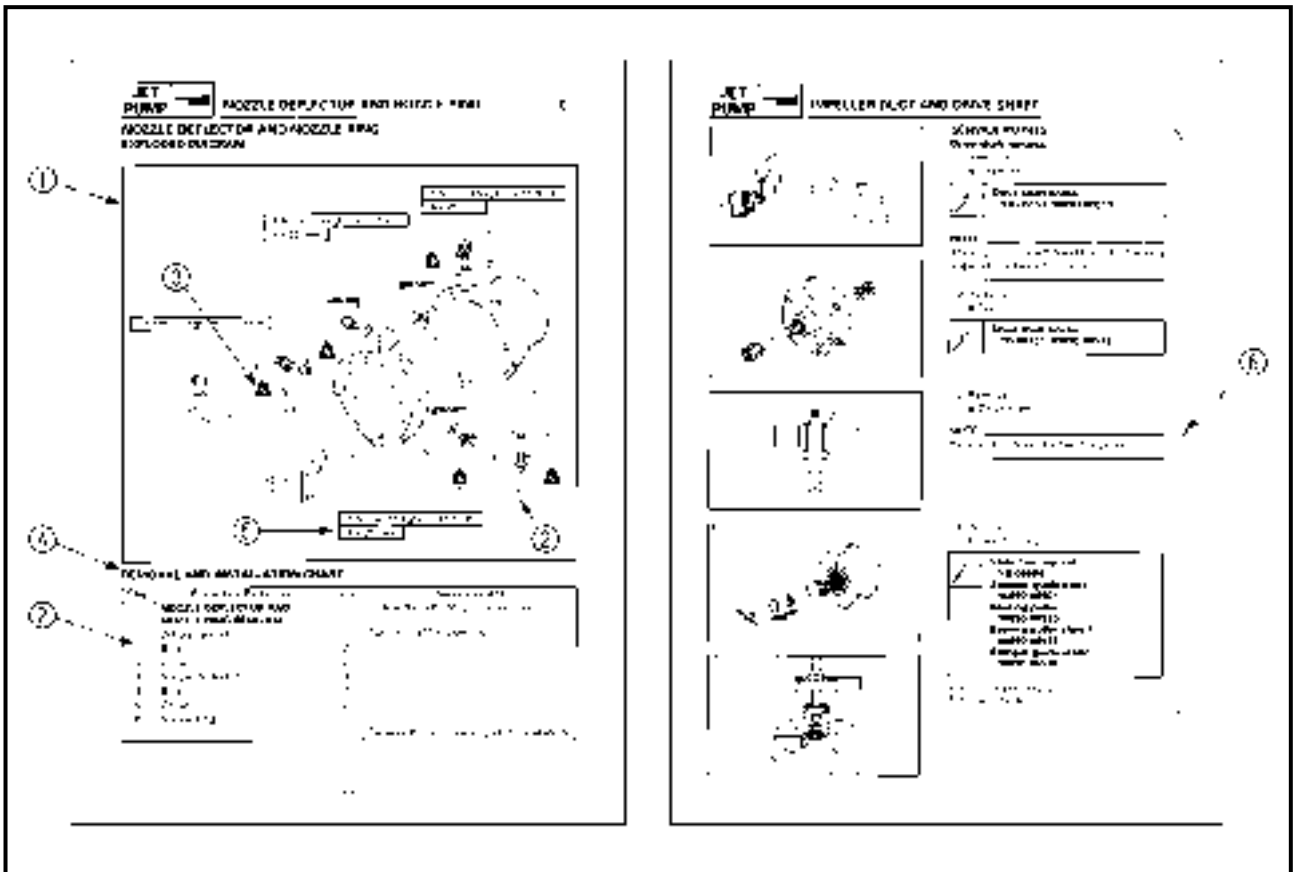

The image shows two pages from a technical manual. The left page is titled 'JET PUMP' and 'NOZZLE DEFLECTOR AND NOZZLE BRAG EXPLODED DIAGRAM'. It features an exploded diagram of a nozzle deflector and nozzle brag assembly with numbered callouts (1, 2, 3, 4, 5) pointing to various parts. Below the diagram is a 'JOB INSTRUCTION CHART' with columns for 'Job No.', 'Part Name', 'Quantity', 'Notes', and 'Torque'. The right page is titled 'JET PUMP' and 'IMPELLER PLUG AND DRIVE SHEET'. It shows a series of four small diagrams illustrating the assembly of the impeller plug and drive sheet. To the right of these diagrams is a 'JOB INSTRUCTION CHART' with columns for 'Job No.', 'Part Name', 'Quantity', 'Notes', and 'Torque'. The charts contain specific instructions and torque values for each step.

A50001-1-4

SYMBOLS

Symbols ① to ⑨ are designed as thumb-tabs to indicate the content of a chapter.

- ① General Information
- ② Specifications
- ③ Periodic Inspection and Adjustment
- ④ Fuel System
- ⑤ Power Unit
- ⑥ Jet Pump Unit
- ⑦ Electrical System
- ⑧ Hull and Hood
- ⑨ Trouble analysis

Symbols ⑩ to ⑮ indicate specific data:

- ⑩ Special tool
- ⑪ Specified liquid
- ⑫ Specified engine speed
- ⑬ Specified torque
- ⑭ Specified measurement
- ⑮ Specified electrical value
[Resistance (Ω), Voltage (V), Electric current (A)]

Symbol ⑯ to ⑰ in an exploded diagram indicate the grade of lubricant and the location of lubrication point:

















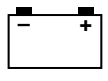





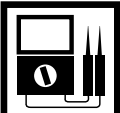

- ⑯ Apply YAMALUBE 2-W oil or TC-W3 certified outboard oil
- ⑰ Apply water resistant grease (Yamaha grease A, Yamaha marine grease)
- ⑱ Apply molybdenum disulfide grease

Symbols ⑲ to ⑳ in an exploded diagram indicate the grade of the sealing or locking agent, and the location of the application point:









- ⑲ Apply Gasket Maker[®]
- ⑳ Apply Yamabond #4 (Yamaha bond number 4)
- ㉑ Apply LOCTITE[®] No. 271 (Red LOCTITE)
- ㉒ Apply LOCTITE[®] No. 242 (Blue LOCTITE)
- ㉓ Apply LOCTITE[®] No. 572
- ㉔ Apply silicone sealant

NOTE: _____

In this manual, the above symbols may not be used in every case.

① GEN INFO 	② SPEC 
③ INSP ADJ 	④ FUEL 
⑤ POWR 	⑥ JET PUMP 
⑦ ELEC 	⑧ HULL HOOD 
⑨ TRBL ANLS 	⑩ 
⑪ 	⑫ 
⑬ 	⑭ 
⑮ 	⑯ 
⑰ 	⑱ 
⑲ 	⑳ 
㉑ 	㉒ 
㉓ 	㉔ 

INDEX

GENERAL INFORMATION	 GEN INFO	1
SPECIFICATIONS	 SPEC	2
PERIODIC INSPECTION AND ADJUSTMENT	 INSP ADJ	3
FUEL SYSTEM	 FUEL	4
POWER UNIT	 POWR	5
JET PUMP UNIT	 JET PUMP	6
ELECTRICAL SYSTEM	 ELEC	7
HULL AND HOOD	 HULL HOOD	8
TROUBLE ANALYSIS	 TRBL ANLS	9

CHAPTER 1 GENERAL INFORMATION



IDENTIFICATION NUMBERS 1-1
 PRIMARY I.D. NUMBER..... 1-1
 ENGINE SERIAL NUMBER 1-1
 JET PUMP UNIT SERIAL NUMBER 1-1
 HULL IDENTIFICATION NUMBER (H.I.N.)..... 1-1

⚠ SAFETY WHILE WORKING 1-2
 FIRE PREVENTION 1-2
 VENTILATION..... 1-2
 SELF-PROTECTION 1-2
 OILS, GREASES AND SEALING FLUIDS..... 1-2
 GOOD WORKING PRACTICES 1-3
 DISASSEMBLY AND ASSEMBLY 1-4

SPECIAL TOOLS 1-5
 MEASURING 1-5
 REMOVAL AND INSTALLATION 1-6

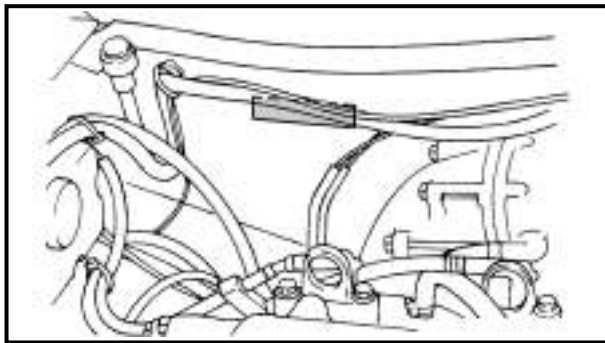

A60700-0*

**IDENTIFICATION NUMBERS
PRIMARY I.D. NUMBER**

The primary I.D. number is stamped on a label attached to the inside of the engine compartment.

**Starting primary I.D. number:
F0W: 800101-**

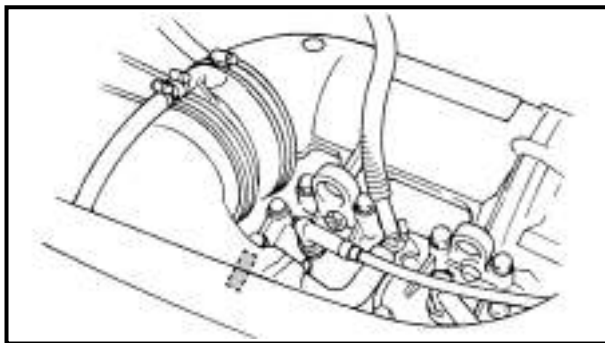

ENGINE SERIAL NUMBER

The engine serial number is stamped on a label attached to the cylinder head.

**Starting serial number:
68A: 000101-**

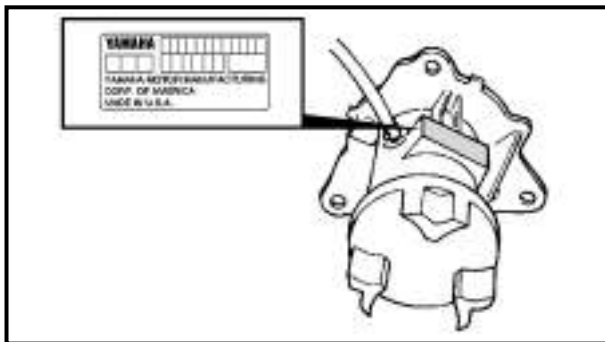

JET PUMP UNIT SERIAL NUMBER

The jet pump unit serial number is stamped on a label attached to the intermediate housing.

**Starting serial number:
68A: 800101-**

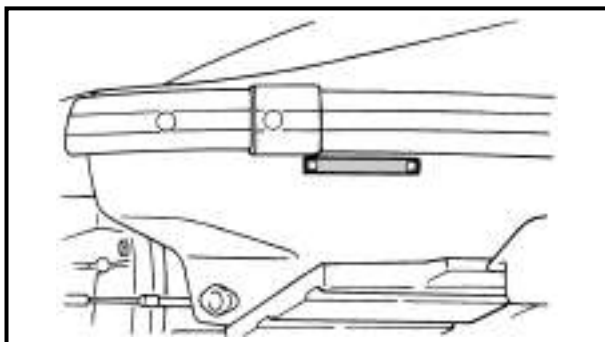

**HULL IDENTIFICATION NUMBER
(H.I.N.)**

The H.I.N. is stamped on a plate attached to the aft deck.

⚠ SAFETY WHILE WORKING

The procedures given in this manual are those recommended by Yamaha to be followed by Yamaha dealers and their mechanics.



FIRE PREVENTION

Gasoline (petrol) is highly flammable. Gasoline vapor is explosive if ignited. Do not smoke while handling gasoline (petrol) and keep it away from heat, sparks, and open flames.

VENTILATION

Gasoline vapor is heavier than air and is deadly if inhaled in large quantities. Engine exhaust gases are harmful to breathe. When test-running an engine indoors, maintain good ventilation.



SELF-PROTECTION

Protect your eyes with suitable safety spectacles or safety goggles when grinding or doing any operation which may cause particles to fly off. Protect hands and feet by wearing safety gloves or protective shoes if appropriate to the work you are doing.



OILS, GREASES AND SEALING FLUIDS

Use only genuine Yamaha oils, greases, and sealing fluids or those recommended by Yamaha.

Under normal conditions of use there should be no hazards from the use of the lubricants mentioned in this manual, but safety is all-important, and by adopting good safety practises any risk is minimized. A summary of the most important precautions is as follows:

1. While working, maintain good standards of personal and industrial hygiene.
2. Clothing which has become contaminated with lubricants should be changed as soon as practicable and laundered before further use.
3. Avoid skin contact with lubricants (e.g., do not place a soiled rag in your pocket).
4. Hands and any other part of the body which have been in contact with lubricants or lubricant-contaminated clothing should be thoroughly washed with hot water and soap as soon as practicable.
5. To protect the skin, the application of a suitable barrier cream to the hands before working is recommended.
6. A supply of clean lint-free cloths should be available for wiping purposes.



GOOD WORKING PRACTICES

1. The right tools

Use the recommended special tools to protect parts from damage. Use the right tool in the right manner – do not improvise.

2. Tightening torque

Follow the tightening torque instructions. When tightening bolts, nuts and screws, tighten the larger sizes first and tighten inner-positioned fixings before outer-positioned ones.

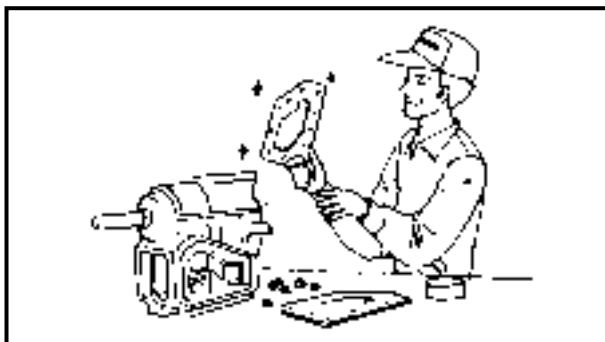

3. Non-reusable items

Always use new gaskets, packings, O-rings, oil seals, split-pins, circlips, etc., on reassembly.



DISASSEMBLY AND ASSEMBLY

1. Clean parts with compressed air when disassembling.
2. Oil the contact surfaces of moving parts during assembly.



3. After assembly, check that moving parts operate normally.

4. Install bearings with the manufacturer's markings on the side exposed to view and liberally oil the bearings.

CAUTION: _____

Do not spin bearings with compressed air because this will damage their surfaces.

5. When installing oil seals, apply a light coat of water-resistant grease to the outside diameter.

SPECIAL TOOLS

Using the correct special tools recommended by Yamaha, will aid the work and enable accurate assembly and tune-up. Improvisations and using improper tools can damage the equipment.

NOTE:

- For U.S.A. and Canada, use part numbers starting with "J-", "YB-", "YM-", "YU-" or "YW-".
- For other countries, use part numbers starting with "90890-".

MEASURING

- ① Engine tachometer
P/N. YU-8036-A
90890-06760
- ② Dial gauge and stand
P/N. YU-03097, YU-01256
90890-01252
- ③ Pocket tester
P/N. YU-03112
90890-03112
- ④ Cylinder gauge set
P/N. YU-03017
90890-06759
- ⑤ Compression gauge
P/N. YU-33223
90890-03160
- ⑥ Digital tester
P/N. J-39299
90890-06752
- ⑦ Peak voltage adapter
P/N. YU-39991
90890-03169
- ⑧ Peak voltage test harness
P/N. YW-06779
90890-06779
- ⑨ Spark gap tester
P/N. YM-34487
90890-06754

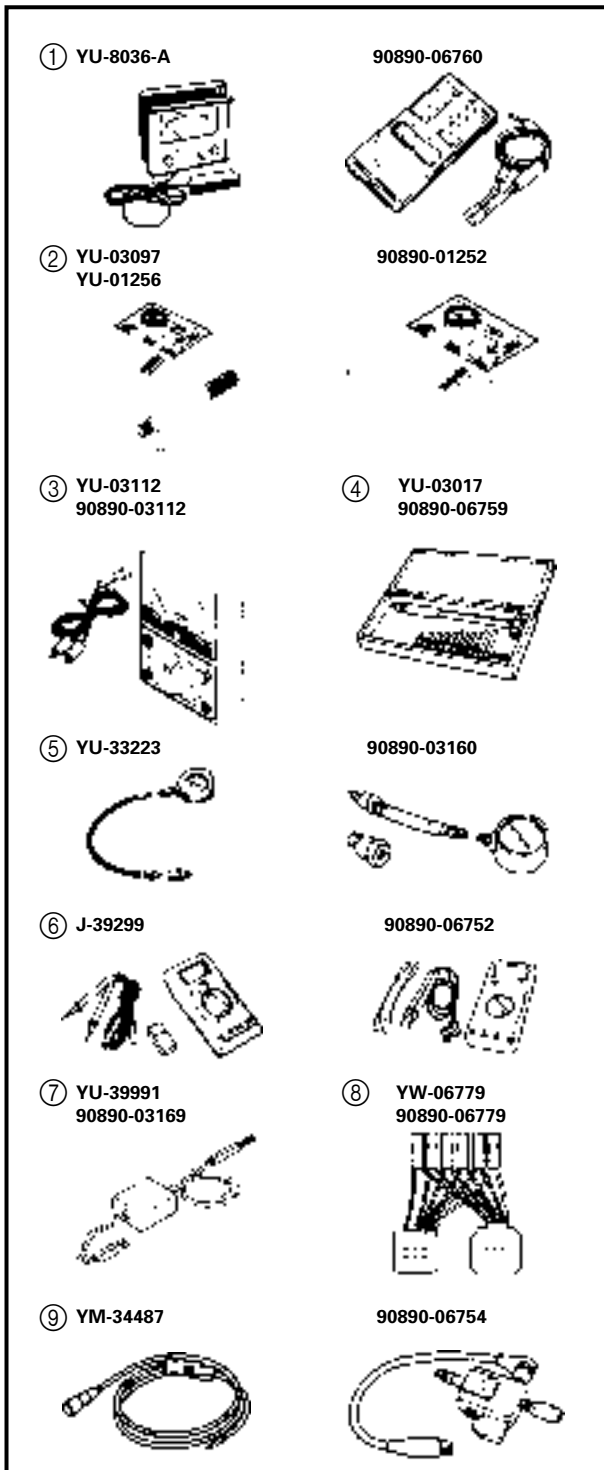

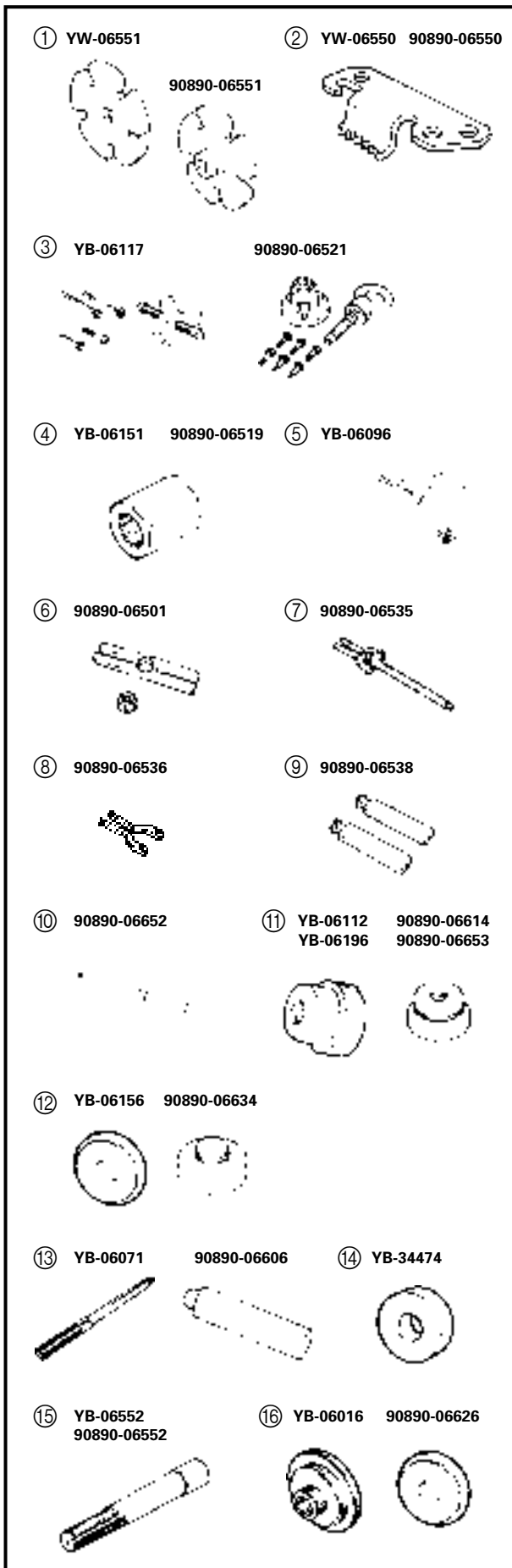

REMOVAL AND INSTALLATION

- ① Coupler wrench
P/N. YW-06551
90890-06551
- ② Flywheel holder
P/N. YW-06550
90890-06550
- ③ Flywheel puller
P/N. YB-06117
90890-06521
- ④ Drive shaft holder (impeller)
P/N. YB-06151
90890-06519
- ⑤ Slide hammer set (jet pump bearing)
P/N. YB-06096
- ⑥ Stopper guide plate (jet pump bearing)
P/N. 90890-06501
- ⑦ Bearing puller (jet pump bearing)
P/N. 90890-06535
- ⑧ Bearing puller claw 1 (jet pump bearing)
P/N. 90890-06536
- ⑨ Stopper guide stand (jet pump bearing)
P/N. 90890-06538
- ⑩ Drive rod L3 (jet pump bearing)
P/N. 90890-06652
- ⑪ Needle bearing attachment
(jet pump bearing and oil seal)
P/N. YB-06112, YB-06196
90890-06614, 90890-06653
- ⑫ Ball bearing attachment
(jet pump oil seal)
P/N. YB-06156
90890-06634
- ⑬ Driver rod
(intermediate shaft and jet pump)
P/N. YB-06071
90890-06606
- ⑭ Bearing inner/outer race attachment
(jet pump bearing)
P/N. YB-34474
- ⑮ Shaft holder (intermediate shaft)
P/N. YB-06552
90890-06552
- ⑯ Bearing outer race attachment
(intermediate shaft)
P/N. YB-06016
90890-06626

CHAPTER 2 SPECIFICATIONS

GENERAL SPECIFICATIONS..... 2-1

MAINTENANCE SPECIFICATIONS..... 2-3

ENGINE..... 2-3

JET PUMP UNIT..... 2-4

HULL AND HOOD..... 2-4

ELECTRICAL..... 2-5

TIGHTENING TORQUES..... 2-7

SPECIFIED TORQUES..... 2-7

GENERAL TORQUE..... 2-10

CABLE AND HOSE ROUTING..... 2-11



GENERAL SPECIFICATIONS



Item	Unit	Model
		GP800R
MODEL CODE		
Hull		F0W
Engine		68A
DIMENSIONS		
Length	mm (in)	2,930 (115.4)
Width	mm (in)	1,150 (45.3)
Height	mm (in)	1,020 (40.2)
Dry weight	kg (lb)	268 (591)
Watercraft capacity		2
PERFORMANCE		
Maximum output	kW (PS) @ r/min	88.2 (120) @ 7,000
Maximum fuel consumption	ℓ /h (US gal/h, Imp gal/h)	49 (12.9, 10.8)
Cruising range	h	1.2
ENGINE		
Engine type		2-stroke
Number of cylinders		2
Displacement	cm ³ (cu. in)	784 (47.8)
Bore × stroke	mm (in)	80.0 × 78.0 (3.15 × 3.07)
Compression ratio		6.6:1
Intake system		Reed valve
Carburetor model (manufacturer) × quantity		BN44 (Mikuni) × 2
Enrichment control		Choke valve
Scavenging system		Loop charge
Lubrication system		Oil injection
Cooling system		Water
Starting system		Electric
Ignition system		Digital CDI
Ignition timing	Degree	15 BTDC–20 BTDC
Spark plug model (manufacturer)		BR8ES (NGK)
Battery capacity	V/Ah (kC)	12/19 (68.4)
Lighting coil	max. A @ r/min	8 @ 6,000
Propulsion system		Jet pump
DRIVE UNIT		
Jet pump type		Axial flow, single stage
Impeller rotation (from rear)		Counterclockwise
Transmission		Direct drive from engine
Nozzle angle (horizontal)	Degree	23 + 23
Nozzle angle (vertical)	Degree	–5, 0, 5, 10, 15
Trim system		Manual 5 positions

Item	Unit	Model
		GP800R
FUEL AND OIL		
Fuel		Regular unleaded gasoline
Fuel rating	PON*	86
	RON*	90
Oil		YAMALUBE 2-W or an equivalent TC-W3 certified outboard oil
Fuel/oil mixing ratio (wide open throttle)		30:1
Fuel tank capacity	ℓ (US gal, Imp gal)	60 (15.9, 13.2)
Fuel tank reserve capacity	ℓ (US gal, Imp gal)	10 (2.6, 2.2)
Oil tank capacity	ℓ (US gal, Imp gal)	5.5 (1.45, 1.21)

PON*: Pump Octane Number = (Motor Octane Number + Research Octane Number)/2

RON*: Research Octane Number

**MAINTENANCE SPECIFICATIONS
ENGINE**

Item	Unit	Model
		GP800R
CYLINDER HEAD		
Warpage limit	mm (in)	0.1 (0.004)
Compression pressure* ¹	kPa (kg/cm ²)	560 (5.6)
CYLINDERS		
Bore size	mm (in)	80.000–80.018 (3.1496–3.1503)
Taper limit	mm (in)	0.08 (0.003)
Out-of-round limit	mm (in)	0.05 (0.002)
Wear limit	mm (in)	Original cylinder bore + 0.04 (0.0016)
PISTONS		
Diameter 	mm (in)	Red: 79.899–79.902 (3.1456–3.1457) Orange: 79.903–79.906 (3.1458–3.1459) Green: 79.907–79.910 (3.1459–3.1461) Purple: 79.911–79.914 (3.1461–3.1462)
Measuring point*	mm (in)	22 (0.87)
Piston-to-cylinder clearance	mm (in)	0.100–0.105 (0.0039–0.0041)
Wear limit	mm (in)	Cylinder bore – 0.105 (0.0041)
Piston pin bore inside diameter	mm (in)	22.004–22.025 (0.8663–0.8671)
PISTON RINGS 		
Top		
Type		Keystone
Dimensions (B)	mm (in)	1.2 (0.05)
Dimensions (T)	mm (in)	2.85 (0.112)
End gap	mm (in)	0.30–0.45 (0.012–0.018)
Ring groove clearance	mm (in)	0.03–0.05 (0.001–0.002)
2nd* ²		
Type		Keystone
Dimensions (B)	mm (in)	1.2 (0.05)
Dimensions (T)	mm (in)	2.85 (0.112)
End gap	mm (in)	0.30–0.45 (0.012–0.018)
Ring groove clearance	mm (in)	0.03–0.05 (0.001–0.002)
PISTON PINS		
Diameter	mm (in)	21.995–22.000 (0.8659–0.8661)
Wear limit	mm (in)	21.990 (0.8657)

*1: At 760 mmHg and 20 °C (68 °F)

*2: The top ring and 2nd ring are of the same type.



Item	Unit	Model
		GP800R
CRANKSHAFT ASSEMBLY		
Crank width ①	mm (in)	72.95–73.00 (2.872–2.874)
Deflection limit ②	mm (in)	0.05 (0.002)
Big end side clearance ③	mm (in)	0.25–0.75 (0.010–0.030)
Maximum small end axial play ④	mm (in)	2.0 (0.08)
CARBURETORS		
Type		Floatless
Identification mark		#1: 68A-01, #2: 68A-02
Main nozzle	mm (in)	3.0 (0.12)
Main jet		150
Pilot jet		90
Throttle valve		120
Valve seat size	mm (in)	1.2 (0.05)
Trolling speed	r/min	1,300 ± 50
REED VALVES		
Thickness	mm (in)	0.52 (0.020)
Reed valve stopper height	mm (in)	10.8–11.4 (0.43–0.45)
Reed valve warpage limit	mm (in)	0.2 (0.01)

JET PUMP UNIT

Item	Unit	Model
		GP800R
JET PUMP		
Impeller material		Stainless steel
Number of impeller blades		3
Impeller pitch angle	Degree	13.2
Impeller clearance	mm (in)	0.35–0.45 (0.014–0.018)
Impeller clearance limit	mm (in)	0.6 (0.024)
Drive shaft runout limit	mm (in)	0.3 (0.012)
Nozzle diameter	mm (in)	86.8 (3.42)

HULL AND HOOD

Item	Unit	Model
		GP800R
FREE PLAY		
YPVS cable slack	mm (in)	0.5–1.5 (0.02–0.06)
Throttle lever free play	mm (in)	4–7 (0.16–0.28)

ELECTRICAL

Item	Unit	Model
		GP800R
BATTERY		
Type		Fluid
Capacity	V/Ah (kC)	12/19 (68.4)
CDI UNIT (O – B)		
Output peak voltage lower limit		
@cranking 1	V	85
@cranking 2	V	110
@2,000 r/min	V	205
@3,500 r/min	V	200
STATOR		
Charge coil (Br – L)		
Output peak voltage lower limit		
@cranking 1	V	90
@cranking 2	V	120
@2,000 r/min	V	220
@3,500 r/min	V	210
Pickup coil (W/R – W/B)		
Output peak voltage lower limit		
@cranking 1	V	5
@cranking 2	V	3
@2,000 r/min	V	7
@3,500 r/min	V	11
Lighting coil (G – G)		
Output peak voltage lower limit		
@cranking 1	V	8.5
@cranking 2	V	8.5
@2,000 r/min	V	13
@3,500 r/min	V	13
Charge coil resistance	Ω (color)	299–365 (Br – L)
Pickup coil resistance	Ω (color)	446–545 (W/R – W/B)
Lighting coil resistance	Ω (color)	0.86–1.06 (G – G)
Minimum charging current	A @ r/min	9 @ 6,000
IGNITION COIL		
Minimum spark gap	mm (in)	10 (0.39)
Primary coil resistance	Ω (color)	0.078–0.106 (O – B)
Secondary coil resistance	kΩ	14.3–30.5
		(#1 Spark plug cap – #2 Spark plug cap)















Cranking 1: unloaded

Cranking 2: loaded





















Item	Unit	Model
		GP800R
RECTIFIER/REGULATOR (R – B) Output peak voltage lower limit (unloaded) @cranking @2,000 r/min @3,500 r/min	V V V	7.5 12.5 12.5
THERMO SWITCH On temperature Off temperature	°C (°F) °C (°F)	80 (177) 70 (159)
STARTER MOTOR Brush length Wear limit Commutator undercut Limit Commutator diameter Limit	mm (in) mm (in) mm (in) mm (in) mm (in) mm (in)	12.5 (0.49) 6.5 (0.26) 0.7 (0.03) 0.2 (0.01) 28.0 (1.10) 27.0 (1.06)
FUSE Rating	V/A	12/10

**TIGHTENING TORQUES
SPECIFIED TORQUES**

Part to tightened	Part name	Thread size	Q'ty	Tightening torque			Remarks	
				N•m	kgf•m	ft•lb		
ENGINE UNIT								
Engine unit – engine mount	Bolt	M8	4	17	1.7	12	 572	
Exhaust chamber assembly – muffler stay 1 – muffler stay 3	1st	Bolt	M10	2	2	0.2	1.4	 271
	4th				51	5.1	37	
	2nd	Bolt	M10	4	2	0.2	1.4	
	6th				39	3.9	28	
	3rd	Nut	M10	2	2	0.2	1.4	
	5th				51	5.1	37	
	7th	Bolt	M10	1	2	0.2	1.4	
	9th				49	4.9	35	
	8th	Bolt	M10	1	2	0.2	1.4	
10th	49				4.9	35		
Exhaust chamber – muffler	1st	Nut	M8	2	15	1.5	11	 271
	2nd				39	3.9	28	
	1st	Bolt	M8	3	15	1.5	11	
	2nd				33	3.3	24	
	1st	Nut	M10	1	15	1.5	11	
	2nd				51	5.1	37	
Exhaust chamber joint – exhaust manifold	1st	Bolt	M8	5	17	1.7	12	 271
	2nd				34	3.4	24	
Exhaust chamber joint – muffler stay	1st	Bolt	M10	1	2	0.2	1.4	 271
	3rd				49	4.9	35	
	2nd	Bolt	M8	2	2	0.2	1.4	
	4th				37	3.7	27	
Exhaust manifold – cylinder	1st	Bolt	M10	8	23	2.3	17	 271
	2nd				51	5.1	37	
Reed valve – reed valve seat	Screw	M3	16	0.8	0.08	0.58	 242	
YPVS cable bracket – YPVS cover – cylinder	Bolt	M6	2	10	1.0	7.2	 572	
YPVS cover – cylinder	Bolt	M6	6	10	1.0	7.2	 572	
YPVS valve assembly – cylinder	Bolt	M5	2	4	0.4	2.9	 271	
YPVS valve lever – shaft	Bolt	M4	2	3	0.3	2.2	 242	
Spark plug – cylinder head	Spark plug	M14	2	25	2.5	18		
Cylinder head – cylinder	1st	Bolt	M8	10	15	1.5	11	 572
	2nd				37	3.7	27	
Cylinder – crankcase	1st	Bolt	M10	8	22	2.2	16	 572
	2nd				39	3.9	28	
Starter motor lead – starter motor	Nut	M6	1	5	0.5	3.6		
Flywheel magneto – crankshaft assembly	Bolt	M10	1	74	7.4	53	 572	



Part to tightened	Part name	Thread size	Q'ty	Tightening torque			Remarks
				N•m	kgf•m	ft•lb	
Drive coupling – crankshaft assembly	Drive coupling	M27	1	36	3.6	25	 572
Generator cover – crankcase	1st	Bolt	8	15	1.5	11	 271
	2nd			27	2.7	19	
Pickup coil – generator cover	Bolt	M5	2	5	0.5	3.6	 242
Cable holder – generator cover	Bolt	M6	2	14	1.4	10	 242
Stator coil – generator cover	Bolt	M6	3	14	1.4	10	 242
Lower crankcase – upper crankcase	1st	Bolt	13	15	1.5	11	 572
	2nd			27	2.7	19	
Mount bracket – crankcase	1st	Bolt	6	15	1.5	11	 271
	2nd			27	2.7	19	
JET PUMP UNIT							
Steering cable joint – nozzle deflector	Nut	M6	1	7	0.7	5.1	 242
Ride plate – hull	Bolt	M8	4	17	1.7	12	 572
Intake duct – hull	Bolt	M8	4	17	1.7	12	 572
Intake grate – hull	Bolt	M6	4	7	0.7	5.1	 572
Speed sensor – ride plate	Screw	M5	4	4	0.4	2.9	 242
Nozzle ring – nozzle	Bolt	M8	2	15	1.5	11	 271
Nozzle deflector – nozzle ring	Bolt	M8	2	15	1.5	11	 271
Water inlet cover – water inlet strainer – impeller duct	Bolt	M6	4	7	0.7	5.1	 572
Drive shaft nut – drive shaft	Nut	M16	1	74	7.4	53	
Impeller (left-hand threads) – drive shaft	Impeller	M22	1	18	1.8	13	 572
Transom plate – hull	Nut	M10	4	26	2.6	19	
Bilge strainer holder – bulkhead	Screw	M5	1	4	0.4	2.9	
Intermediate housing – bulkhead	Bolt	M8	3	17	1.7	12	 572
Driven coupling – shaft	Driven coupling	M27	1	36	3.6	25	 572
Grease nipple – intermediate housing	Nipple	—	1	5	0.5	3.6	 572
HULL AND HOOD							
Handlebar cover – handlebar cover stay	Screw	M6	4	1.1	0.11	0.8	
Handlebar cover stay – steering column	Screw	M6	4	2.9	0.29	2.1	
Upper handlebar holder/lower handle holder – steering column	Bolt	M8	4	16	1.6	11	
QSTS converter – hull	Nut	M6	2	5	0.5	3.6	
QSTS cable 1, 2 locknut	Nut	M8	2	16	1.6	11	
Throttle lever assembly – handlebar	Screw	M5	2	3	0.3	2.2	



Part to tightened	Part name	Thread size	Q'ty	Tightening torque			Remarks
				N•m	kgf•m	ft•lb	
Handlebar switch assembly – handlebar	Screw	M5	2	3	0.3	2.2	
QSTS grip assembly – handlebar	Screw	M6	1	3	0.3	2.2	
Grip end – handlebar	Bolt	M5	2	1	0.1	0.7	
Choke lever assembly – handlebar	Screw	M5	2	3	0.3	2.2	
QSTS cable housing – cover	Screw	M4	1	1	0.1	0.7	
Plate/steering column assembly – deck	Nut	M8	2	16	1.6	11	
Steering column assembly – deck	Nut	M8	2	16	1.6	11	
Steering arm – steering column	Nut	M8	1	16	1.6	11	
Steering cable ball joint – steering arm	Nut	M6	1	5	0.5	3.6	
Handlebar stopper – steering column housing	Nut	M10	1	26	2.6	19	
QSTS cable locknut (nozzle ring side)	Nut	M5	1	3	0.3	2.2	
QSTS cable – hull	Nut	—	1	6	0.6	4.3	
QSTS cable end – pin – QSTS converter	Nut	M6	1	4	0.4	2.9	
Steering cable locknut (nozzle deflector side)	Nut	M6	1	6	0.6	4.3	
Steering cable – hull	Nut	—	1	6	0.6	4.3	
Steering cable holder – bracket	Bolt	M6	1	6	0.6	4.3	
Speed sensor lead – hull	Nut	—	1	6	0.6	4.3	
Hinge assembly – front hood	Bolt	M6	2	12	1.2	8.7	
Wind shield – front hood	Screw	M5	8	1	0.1	0.7	
Hood lock – front hood	Bolt	M6	2	5	0.5	3.6	
Hinge assembly – deck	Nut	M8	2	16	1.6	11	
Steering console cover assembly – deck	Nut	M6	2	5	0.5	3.6	
	Bolt	M6	4	3	0.3	2.2	
	Screw	M5	2	2	0.2	1.4	
	Nut	M8	2	16	1.6	11	
Multifunction meter – holder	Nut	M5	2	2	0.2	1.4	
Steering console cover – side cover	Screw	M6	4	3	0.3	2.2	
Steering console cover – glove compartment	Screw	M5	4	1	0.1	0.7	
Steering cable bracket – deck	Bolt	M6	1	6	0.6	4.3	
Buzzer bracket – deck – steering cable bracket	Bolt	M6	2	6	0.6	4.3	
Hood lock assembly – deck	Nut	M6	2	6	0.6	4.3	
Seat lock assembly – seat	Bolt	M6	2	6	0.6	4.3	
Bracket/deck – notch	Nut	M10	1	26	2.6	19	
Bracket/deck – hand grip	Bolt	M8	2	5	0.5	3.6	



Part to tightened	Part name	Thread size	Q'ty	Tightening torque			Remarks
				N•m	kgf•m	ft•lb	
Hand grip – deck	Nut	M8	2	5	0.5	3.6	
Seat bracket – deck	Nut	M8	2	15	1.5	11	
Battery box/stay – holder	Nut	M6	2	9	0.9	6.5	
Battery box – bracket/deck	Nut	M8	2	13	1.3	9.4	
Battery box – electrical box	Bolt	M8	3	15	1.5	11	
Extension bolt – battery negative terminal	Bolt	M6	1	6	0.6	4.3	
Exhaust outlet – hull	Bolt	M6	3	6	0.6	4.3	
Sponson – hull	Bolt	M8	6	18	1.8	13	
Spout – hull	Nut	M24	1	5	0.5	3.6	
Rope hole – hull	Nut	M24	2	5	0.5	3.6	
Bow eye – hull	Bolt	M6	2	13	1.3	9.4	
Flap – hull	Bolt	M6	8	6	0.6	4.3	
Drain plug/packing – hull	Nut	M5	4	2	0.2	1.4	
Engine mount – hull	Bolt	M8	8	17	1.7	12	
Engine damper – hull	Bolt	M6	2	6	0.6	4.3	

Nut [Ⓐ]	Bolt [Ⓑ]	General torque specifications		
		N•m	kgf•m	ft•lb
8 mm	M5	5.0	0.5	3.6
10 mm	M6	8.0	0.8	5.8
12 mm	M8	18	1.8	13
14 mm	M10	36	3.6	25
17 mm	M12	43	4.3	31

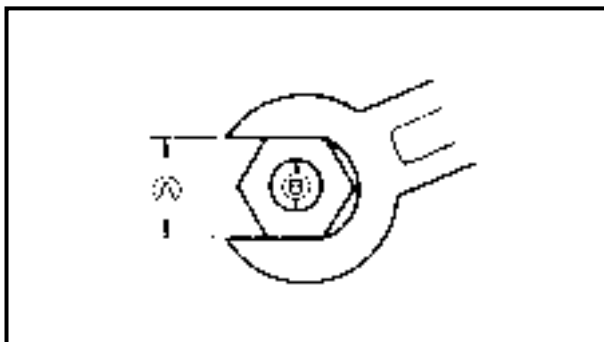

GENERAL TORQUE

This chart specifies tightening torques for standard fasteners with a standard ISO thread pitch. Tightening torque specifications for special components or assemblies are provided in applicable sections of this manual. To avoid warpage, tighten multi-fastener assemblies in a crisscross fashion and progressive stages until the specified tightening torque is reached. Unless otherwise specified, tightening torque specifications require clean, dry threads. Components should be at room temperature.



CABLE AND HOSE ROUTING

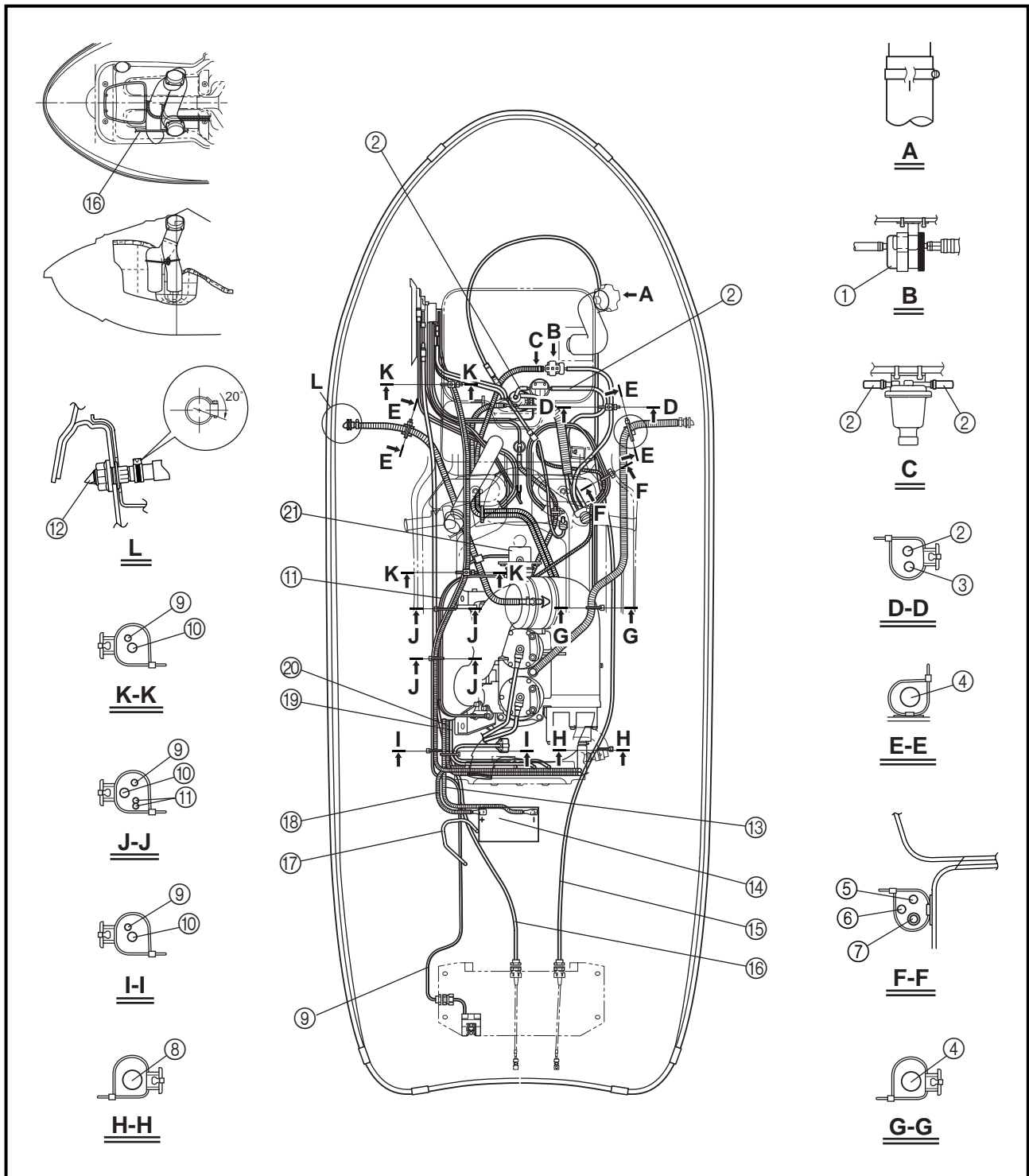

- ① Fuel filter
- ② Fuel tank breather hose
- ③ Fuel hose
- ④ Cooling water hose
- ⑤ Choke cable
- ⑥ Throttle cable
- ⑦ Oil return hose
- ⑧ Bilge hose

- ⑨ Speed sensor lead
- ⑩ Electrical box lead
- ⑪ YPVS cables
- ⑫ Cooling water pilot outlet
- ⑬ Battery negative lead
- ⑭ Battery
- ⑮ Steering cable
- ⑯ QSTS cable

- ⑰ Battery breather hose
- ⑱ Battery positive lead
- ⑲ Starter motor lead
- ⑳ Generator lead
- ㉑ YPVS servomotor

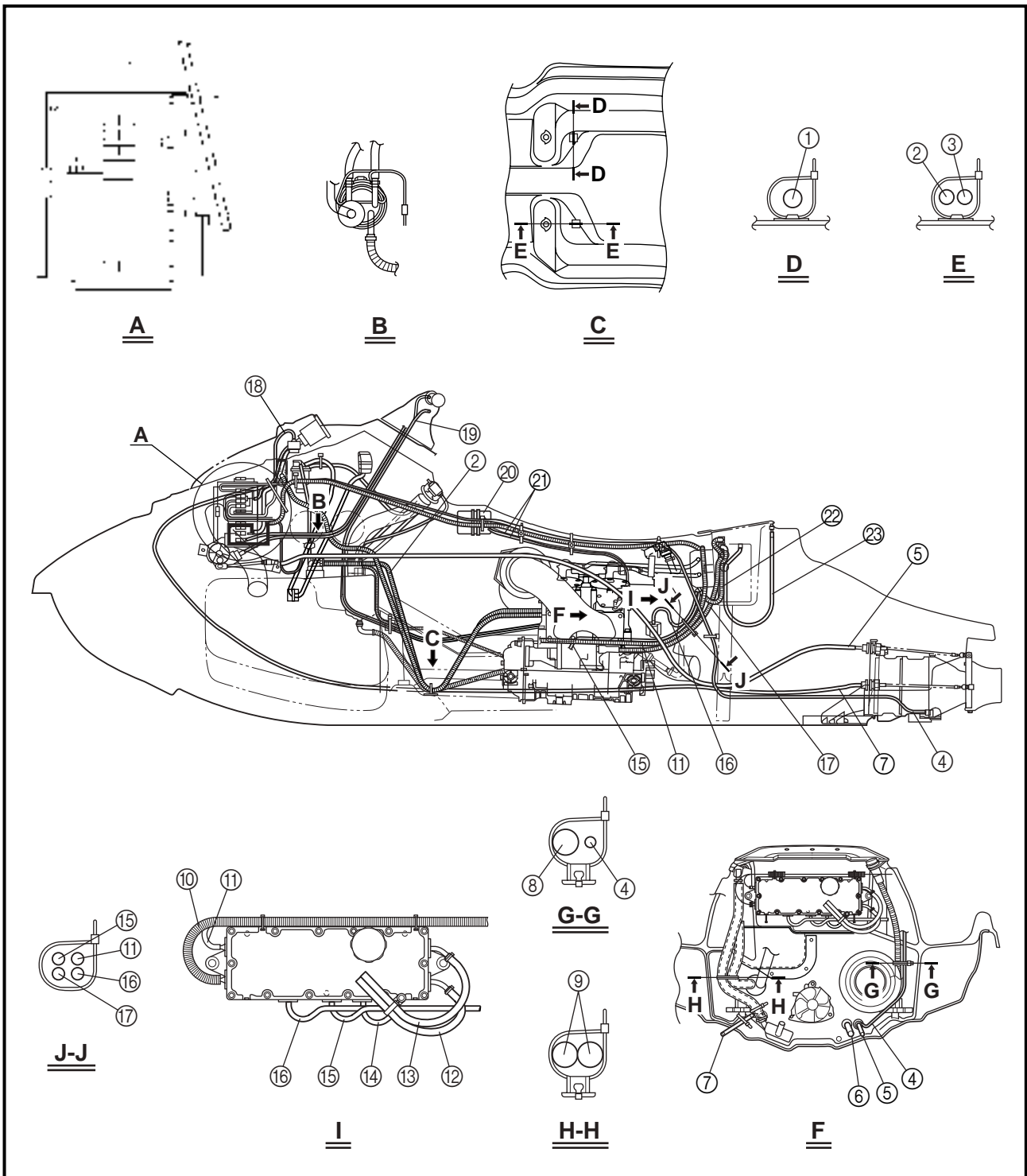

- ① Oil delivery hose
- ② Fuel return hose
- ③ Fuel suction hose
- ④ Speed sensor lead
- ⑤ QSTS cable
- ⑥ Cooling water hose
- ⑦ Steering cable
- ⑧ Flushing hose

- ⑨ Bilge hoses
- ⑩ To multifunction meter
- ⑪ To stator assembly
- ⑫ To cylinder #1
- ⑬ To cylinder #2
- ⑭ To battery positive terminal
- ⑮ To starter motor positive terminal

- ⑯ To thermostat
- ⑰ Battery negative lead
- ⑱ Buzzer lead
- ⑲ Choke cable
- ⑳ YPVS servomotor
- ㉑ YPVS cables
- ㉒ Battery positive lead
- ㉓ Battery breather hose

CHAPTER 3

PERIODIC INSPECTION AND ADJUSTMENT

MAINTENANCE INTERVAL CHART	3-1
PERIODIC SERVICE	3-2
CONTROL SYSTEM	3-2
Steering column inspection	3-2
Steering cable inspection and adjustment	3-2
Throttle cable inspection and adjustment	3-3
Choke cable inspection and adjustment	3-4
QSTS cable inspection and adjustment	3-5
YPVS cable adjustment	3-6
FUEL SYSTEM.....	3-7
Fuel line inspection	3-7
Trolling speed check and adjustment	3-8
OIL INJECTION SYSTEM.....	3-9
Oil line inspection	3-9
POWER UNIT.....	3-9
Spark plug inspection	3-9
ELECTRICAL	3-10
Battery inspection	3-10
JET PUMP UNIT.....	3-13
Impeller inspection	3-13
Water inlet strainer inspection.....	3-14
Bilge strainer inspection.....	3-14
GENERAL.....	3-14
Drain plug inspection.....	3-14
Lubrication points	3-15

MAINTENANCE INTERVAL CHART

The following chart should be considered strictly as a guide to general maintenance intervals. Depending on operating conditions, the intervals of maintenance should be changed.

Item	Remarks	Initial		Every		Refer to page
		10 hours (Break-in)	50 hours (3 months)	100 hours (6 months)	200 hours (1 year)	
CONTROL SYSTEM						
Steering cable	Inspect/adjust			○		3-2
Steering column	Inspect	○		○		3-2
Throttle cable	Inspect/adjust			○		3-3
Carburetor throttle shaft	Inspect/adjust			○		—
Choke cable	Inspect/adjust			○		3-4
QSTS cable	Inspect/adjust			○		3-5
YPVS cable	Inspect/adjust				○	3-6
FUEL SYSTEM						
Fuel tank	Clean				○	4-9
Fuel filter	Clean/replace	○			○	3-7
Fuel line	Inspect			○		3-7
Trolling speed	Check/adjust			○		3-8
Carburetor setting	Inspect/adjust			○		4-18
OIL INJECTION SYSTEM						
Oil injection system	Check/clean				○	3-9
Oil pump cable	Inspect/adjust			○		4-30
POWER UNIT						
Spark plugs	Inspect/clean/adjust	○	○	○		3-9
Cooling water passage	Inspect/clean	○ ^{*1}				—
Rubber coupling	Inspect				○	—
ELECTRICAL						
Battery	Inspect	○ ^{*2}				3-10
JET PUMP UNIT						
Impeller	Inspect		○	○		3-13
Water inlet strainer	Clean		○	○		3-14
Bilge strainer	Clean		○	○		3-14
GENERAL						
Bolts and nuts	Retighten	○		○		—
Drain plugs	Inspect/replace				○	3-14
Lubrication points	Grease			○		3-15
Intermediate housing	Grease	○ ^{*3}		○ ^{*4}		3-17

*1: After every ride

*2: Inspect fluid level before every ride

*3: Grease capacity 33.0–35.0 cm³ (1.11–1.18 oz)

*4: Grease capacity 6.0–8.0 cm³ (0.20–0.27 oz)

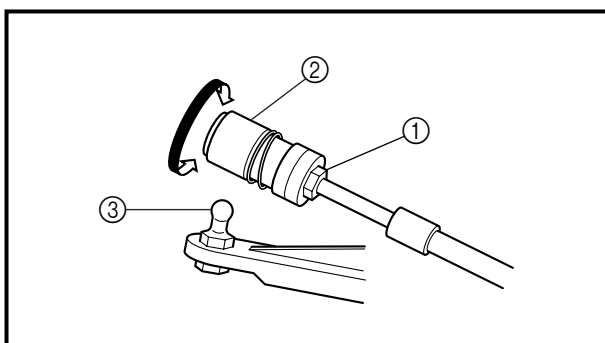
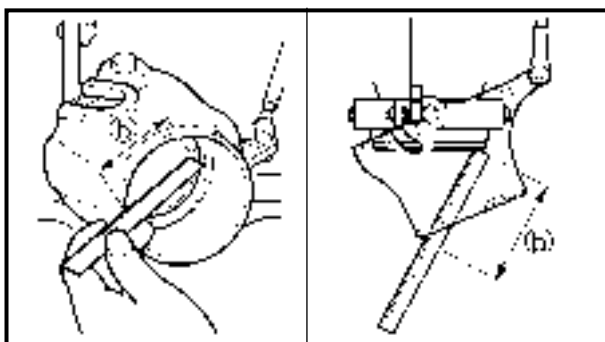
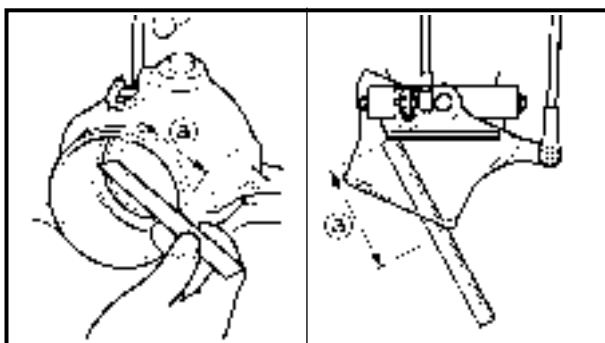
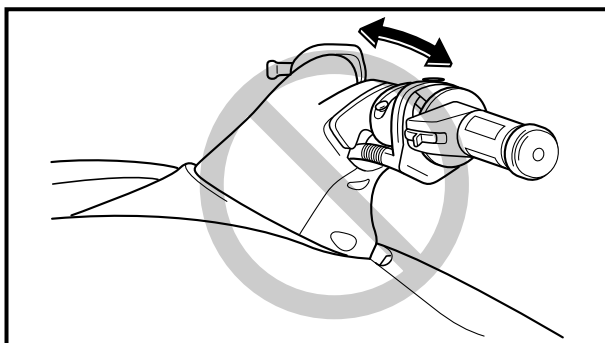
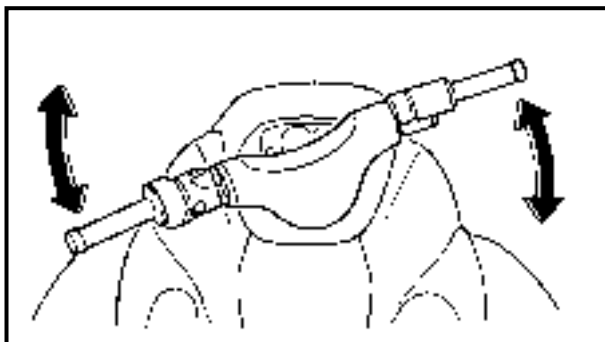

**PERIODIC SERVICE
CONTROL SYSTEM**

Steering column inspection

1. Inspect:
 - Steering column
Excessive play → Replace the steering column.
Refer to “STEERING COLUMN” in chapter 8.

Inspection steps:

- Move the handlebar up and down and back and forth.
- Check the excessive play of the handlebar.

Steering cable inspection and adjustment

1. Inspect:
 - Distance (a), (b) (between the nozzle and nozzle deflector)
Out of specification → Adjust.

Inspection steps:

- Set the control grip in the neutral position.
- Turn the handlebar from lock to lock.
- Measure distances (a) and (b).
- If the difference is not within specification, adjust the cable joint.

**Difference of distances (a) and (b):
Maximum 5 mm (0.2 in)**

2. Adjust:
 - Steering cable joint
(steering column side)

Adjustment steps:

- Loosen the locknut (1).
- Disconnect the steering cable joint (2) from the ball joint (3).
- Turn the cable joint in or out for adjusting the distances (a) and (b).

Turn in	Distance (a) is increased.
Turn out	Distance (b) is increased.

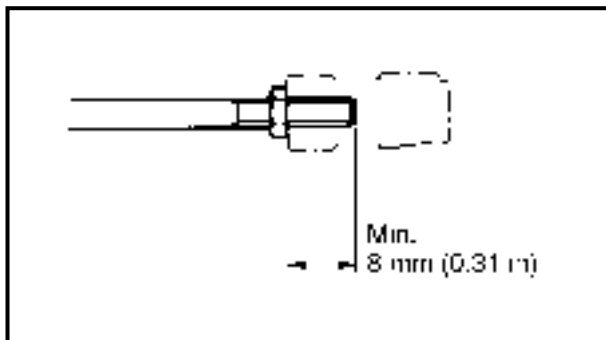

⚠ WARNING

The cable joint must be screwed in more than 8 mm (0.31 in).

- Connect the cable joint and tighten the locknut.



Locknut:
6 N · m (0.6 kgf · m, 4.3 ft · lb)

NOTE:

If the steering cable cannot be properly adjusted at the steering column side, make sure the steering cable at the jet pump side is set to the specified length. Refer to "REMOTE CONTROL CABLES AND SPEED SENSOR LEAD" in chapter 8.

Throttle cable inspection and adjustment

NOTE:

Before adjusting the throttle lever free play, adjust the trolling speed.

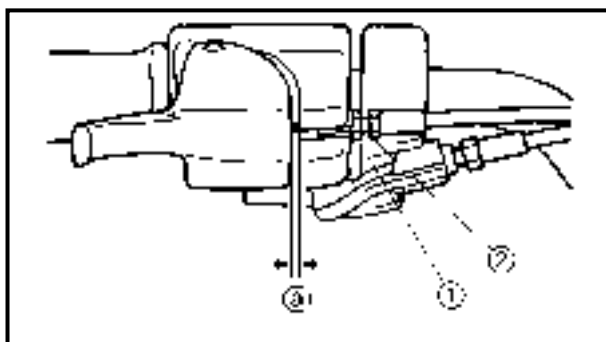

1. Measure:

- Throttle lever free play ③
- Out of specification → Adjust.



Throttle lever free play:
4–7 mm (0.16–0.28 in)

2. Adjust:

- Throttle lever free play

Adjustment steps:

- Loosen the locknut ①.
- Turn the adjuster ② in or out until the specified free play is obtained.

Turn in	Free play is increased.
----------------	--------------------------------

Turn out	Free play is decreased.
-----------------	--------------------------------

- Tighten the locknut.



⚠ WARNING

After adjusting the free play, turn the handlebar to the right and left and make sure that the trolling speed does not increase.

Choke cable inspection and adjustment

1. Check:
 - Choke lever operation
 Incorrect operation → Adjust.

Checking steps:

- Check that the choke lever moves back slightly when it is fully opened.
- Check that the inner cable has some slack when the choke lever is completely closed.

2. Adjust:

- Choke lever operation

Adjustment steps:

- Loosen the locknut ①.
- Screw the adjuster ② fully into the bracket.
- Align the choke lever end ③ within the line marks ④.
- Turn out the adjuster ② until the inner cable is taut.

NOTE:

If the inner cable is difficult to make taut using the adjuster ②, adjust the choke lever so that the cable is taut. The cable must be taut when the choke lever end ③ is positioned within the line marks ④. Reset the adjuster if necessary.

- Tighten the locknut ①.

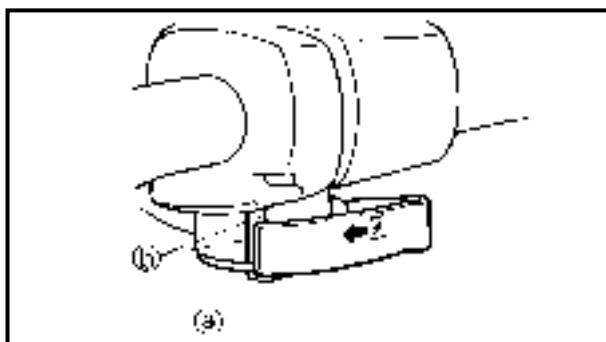
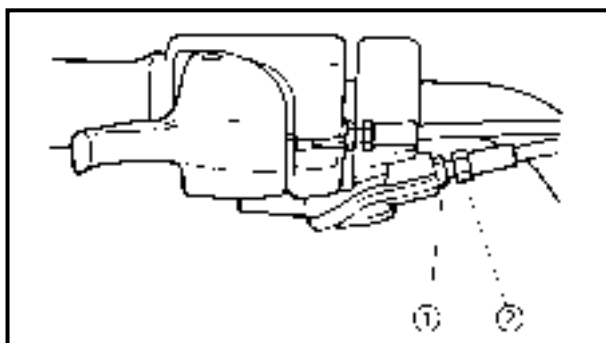

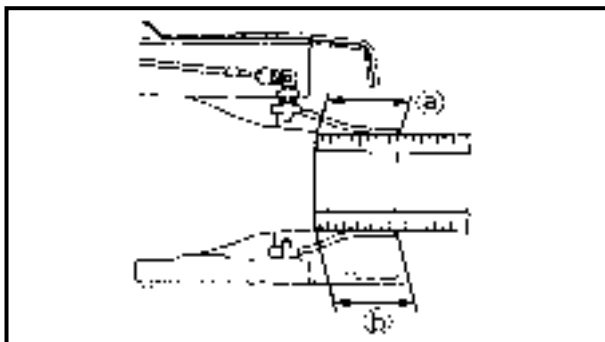

QSTS cable inspection and adjustment

1. Measure:
 - Nozzle deflector set length ①, ②
 Difference → Adjust.

Measurement steps:

- Set the control grip in the neutral position.
- Measure the nozzle deflector set length ① and ②.
- If ① and ② length are not even, adjust the cable joint.

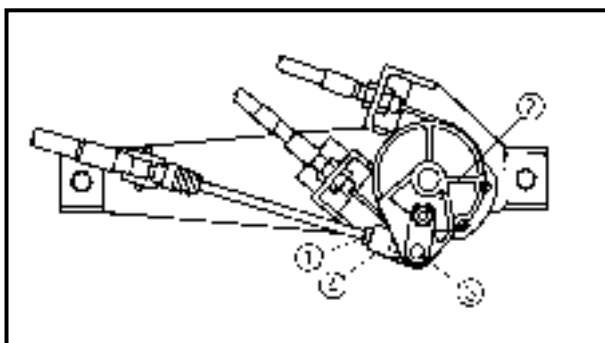

2. Adjust:
 - QSTS cable

Adjustment steps:

- Set the control grip in the neutral position.
- Loosen the locknut ①.
- Remove the nut ② and pivot pin ③.
- Set the nozzle deflector in the center position.
- Turn the cable joint ④ for adjusting.

Turn in	Length ② is increased.
Turn out	Length ① is increased.

⚠ WARNING
The cable joint must be screwed in more than 8 mm (0.31 in).

- Connect the cable joint ④ and pivot pin ③ and tighten the nut ②.



Nut:
4 N • m (0.4 kgf • m, 2.9 ft • lb)

- Tighten the locknut ①.



Locknut:
4 N • m (0.4 kgf • m, 2.9 ft • lb)

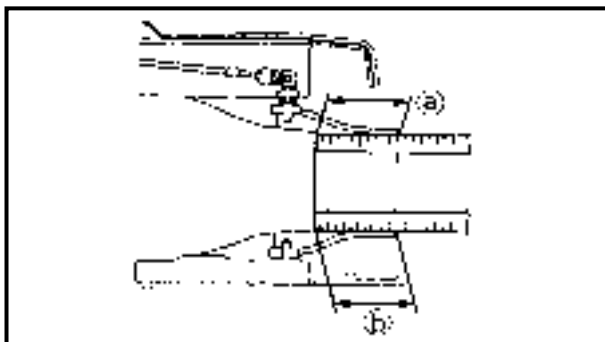

NOTE: _____

If the QSTS cable cannot be properly adjusted at the QSTS converter side, make sure the QSTS cable at the jet pump side is set to the specified length.

Refer to "REMOTE CONTROL CABLES AND SPEED SENSOR LEAD" in chapter 8.

YPVS cable adjustment

1. Check:

- YPVS valve position

Incorrect position → Adjust the YPVS cable.

Checking steps:

- Start the engine and then stop it.

NOTE: _____

When the engine has been stopped for 3 seconds, the YPVS valve assembly will retract and extend one time.

- Check that the hole @ in the pulley is aligned with the hole in the cylinder when the YPVS valve is fully closed.

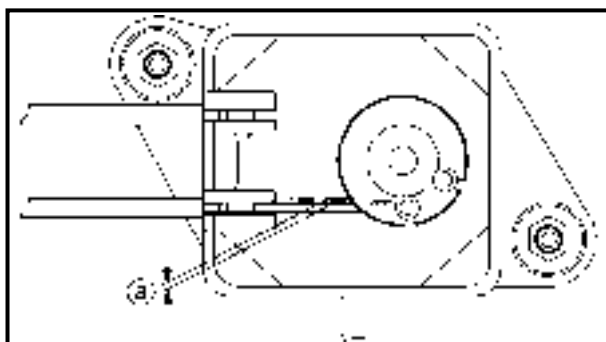
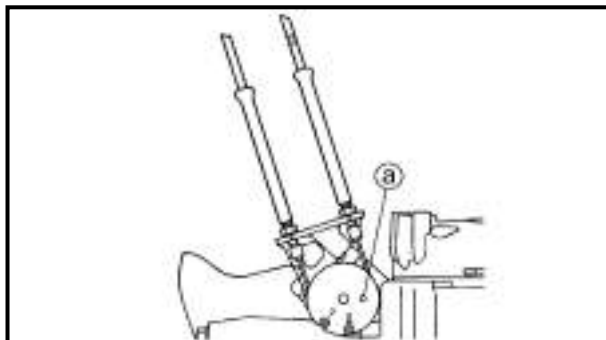

2. Measure:

- YPVS cable slack @

Out of specification → Adjust.



YPVS cable slack:
0.5–1.5 mm (0.02–0.06 in)

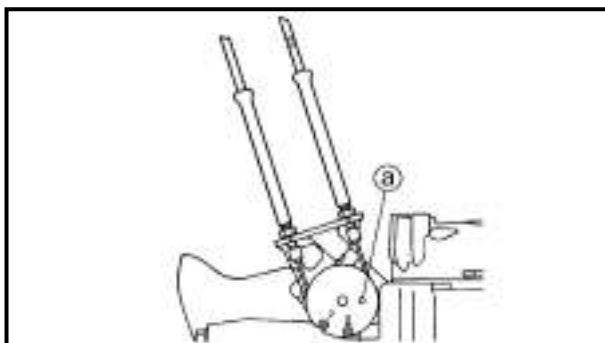
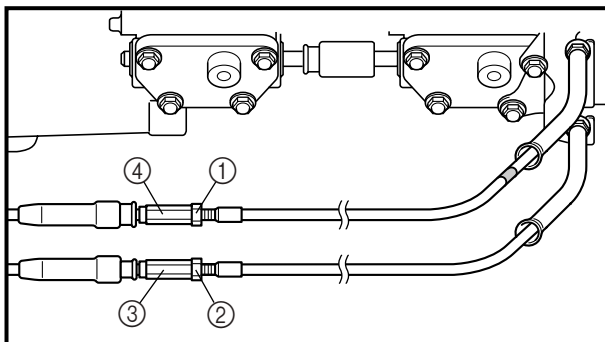

3. Adjust:

- YPVS cables 1 and 2

Adjustment steps:

- Loosen locknuts ① and ②.
- Turn in adjusters ③ and ④ until there is slack in the cables.
- Align the hole **a** in the pulley with the hole in the cylinder.
- Insert a 4-mm-diameter pin through the holes in the pulley and cylinder.
- Turn adjusters ③ and ④ in or out until the specified slack is obtained.

Turn in	Slack is increased.
Turn out	Slack is decreased.

- Finger tighten locknuts ① and ②.
- Remove the pin.
- Start and stop the engine.
- Recheck the hole alignment.
- If the hole alignment is correctly, tighten the locknuts.
- If the hole alignment is incorrect, repeat the above steps.

FUEL SYSTEM

⚠ WARNING

- **Stop the engine, set the fuel cock to "OFF" before servicing the fuel system.**
- **When removing fuel system parts, wrap them in a cloth and take care that no fuel spills into the engine compartment.**

Fuel line inspection

1. Inspect:

- Fuel filter ①
Contaminants → Replace.
Cracks/damage → Replace.
Water contamination → Replace and check the fuel tank.
- Fuel hoses
- Fuel tank
- Fuel hoses through part
- Fuel filler cap
Cracks/damage → Replace.

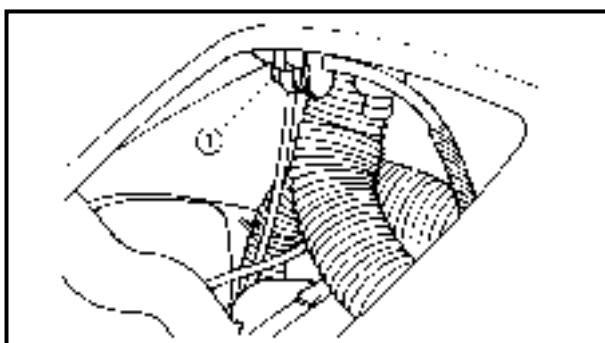

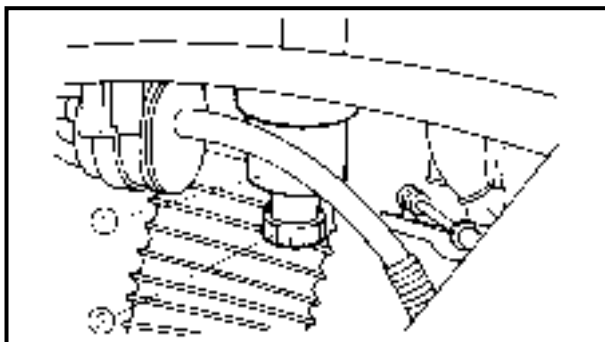

2. Inspect:

- Water separator ①
Water accumulation → Drain.

NOTE:

If need the water draining, remove the drain plug ②.

Trolling speed check and adjustment

1. Check:

- Trolling speed
Out of specification → Adjust.

	Trolling speed: 1,300 ± 50 r/min
--	---

Checking steps (with the watercraft in the water):

- Start the engine and allow it to warm up for several minutes.
- Attach the engine tachometer to the spark plug lead.

	Engine tachometer: YU-8036-A/90890-06760
--	---

- Measure the engine trolling speed.

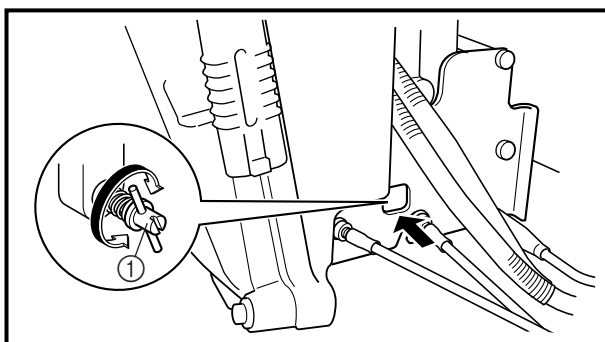

2. Adjust:

- Trolling speed

Adjustment steps:

- Start the engine and allow it to warm up for several minutes.
- Attach the engine tachometer to the spark plug lead.

	Engine tachometer: YU-8036-A/90890-06760
--	---

- Turn the throttle stop screw ① in or out until the specified trolling speed is obtain.

OIL INJECTION SYSTEM

Oil line inspection

1. Inspect:
 - Oil filter
Contaminants → Clean.
Frays/tears → Replace.
 - Rubber seal
Cracks/wear → Replace.
 - Oil hoses
 - Oil tank
 - Oil filler cap
Cracks/damage → Replace.
 - Check valve
Malfunction → Replace.

CAUTION:

Do not allow the oil tank to become completely empty. If the oil tank becomes empty the oil injection pump must be bled to ensure proper oil flow, otherwise engine damage may occur. Refer to "OIL PUMP" in chapter 4.

POWER UNIT

Spark plug inspection

1. Inspect:
 - Electrodes ①
Damage/wear → Replace.
 - Insulator color ②
Distinctly different color → Check the engine condition.

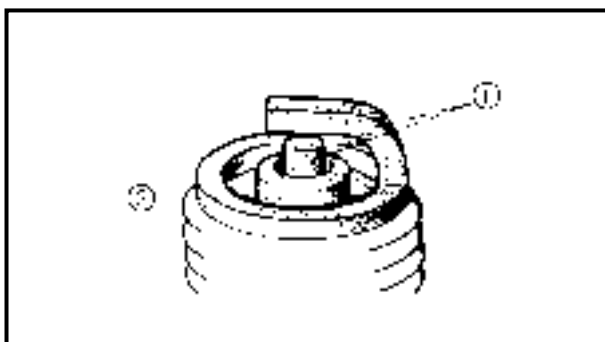

Color guide:

Medium to light tan color:

Normal

Whitish color:

Lean fuel mixture

Air leak

Incorrect settings

Blackish color:

Overly rich mixture

Electrical malfunction

Excessive oil use

Defective spark plug

2. Clean:
 - Spark plug
(with a spark plug cleaner or wire brush)

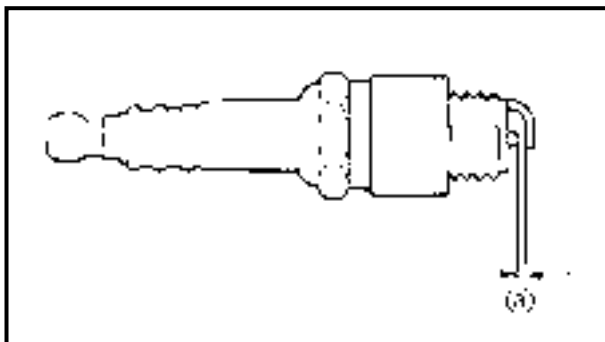

3. Measure:

- Spark plug gap (a)
Out of specification → Regap.



Spark plug gap:
0.7–0.8 mm (0.028–0.031 in)

4. Tighten:

- Spark plug



Spark plug:
25 N · m (2.5 kgf · m, 18 ft · lb)

NOTE:

- Before installing the spark plug, clean the gasket surface and spark plug surface. Also, it is suggested to apply a thin film of anti-seize compound to the spark plug threads to prevent thread seizure.
- If a torque wrench is not available, a good estimate of the correct tightening torque for a new spark plug is to finger tighten (a) the spark plug and then tighten it another 1/4 to 1/2 of a turn (b).

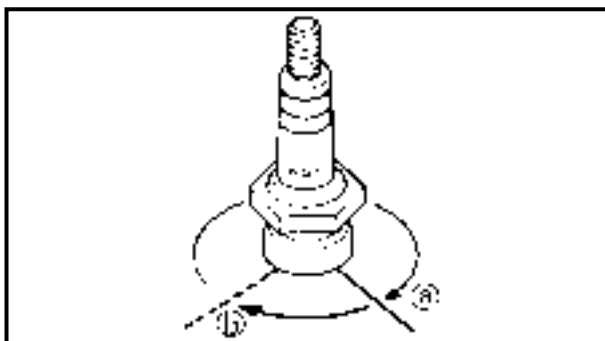

ELECTRICAL

Battery inspection

⚠ WARNING

Battery electrolyte is dangerous; it contains sulfuric acid which is poisonous and highly caustic.

Always follow these preventive measures:

- **Avoid bodily contact with electrolyte as it can cause severe burns or permanent eye injury.**
- **Wear protective eye gear when handling or working near batteries.**

Antidote (EXTERNAL):

- **SKIN - Wash with water.**
- **EYES - Flush with water for 15 minutes and get immediate medical attention.**



Antidote (INTERNAL):

- Drink large quantities of water or milk followed with milk of magnesia, beaten egg or vegetable oil. Get immediate medical attention.

Batteries generate explosive, hydrogen gas. Always follow these preventive measures:

- Charge batteries in a well-ventilated area.
- Keep batteries away from fire, sparks or open flames (e.g., welding equipment, lighted cigarettes).
- **DO NOT SMOKE** when charging or handling batteries.

KEEP BATTERIES AND ELECTROLYTE OUT OF REACH OF CHILDREN.

CAUTION:

- Do not place the battery on its side.
- Before adding electrolyte or recharging, be sure to remove the battery from the battery box.
- Make sure that the battery breather hose is properly connected and is not pinched or damaged.

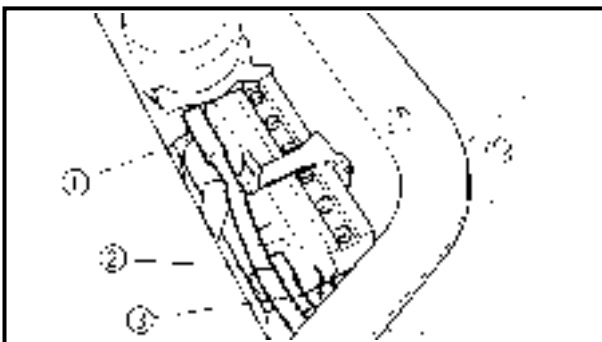

1. Remove:

- Band
- Battery negative lead ①
- Battery positive lead ②
- Battery
- Battery breather hose ③

⚠ WARNING

- When removing the battery, disconnect the negative lead first.
- Remove the battery to prevent acid loss during turning the machine on its side for the impeller service.

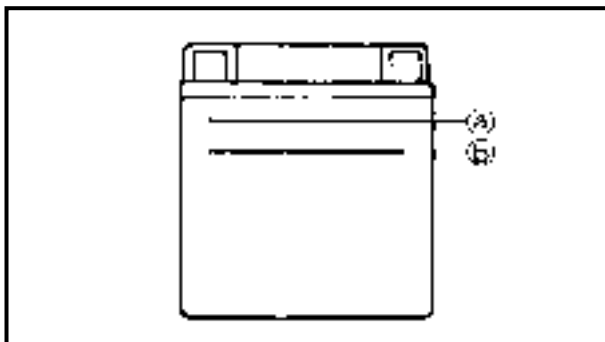

2. Inspect:

- Electrolyte level
Low → Add distilled water.
The electrolyte level should be between the upper ① and lower ② level marks.

Filling steps:

- Remove each filler cap.
- Add distilled water.
- When the electrolyte level reaches the upper level mark, allow the cell to stand for 20 minutes. If the electrolyte level drops, add more distilled water so the level reaches the upper level mark.

CAUTION: _____

Use only distilled water. Other types of water contain minerals which are harmful to batteries.

3. Inspect:

- Specific gravity
Out of specification → Charge.



Specific gravity at 20 °C (68 °F):
1.28
Charging current:
1.9 amps × 10 hrs (68.4 kC)

4. Install:

- Filler caps

CAUTION: _____

Before installation, rinse off any fluid from the battery box and battery and make sure that the battery is dry before installing it.

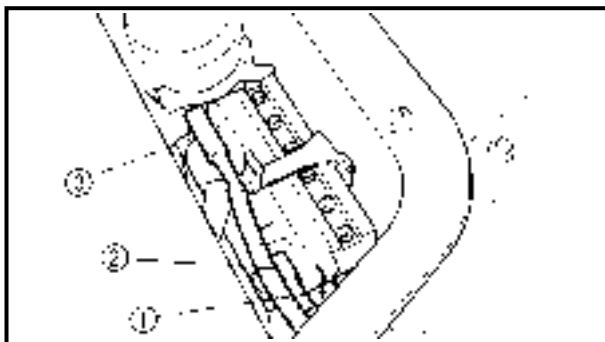

5. Install:
- Battery breather hose ①
 - Battery
 - Battery positive lead ②
 - Battery negative lead ③ (with terminal extension at battery negative terminal)
 - Band

CAUTION:

- Connect the positive lead to the battery terminal first.
- Make sure the battery leads are connected properly. Reversing the leads can seriously damage the electrical system.
- Make sure that the battery breather hose is properly connected and is not obstructed.
- Coat the terminals with a water resistant grease to minimize terminal corrosion.



JET PUMP UNIT

Impeller inspection

1. Check:
 - Impeller ①
Damage/wear → Replace.
Nicks/scratches → File or grind.
2. Measure:
 - Impeller-to-housing clearance ②
Out of specification → Replace.

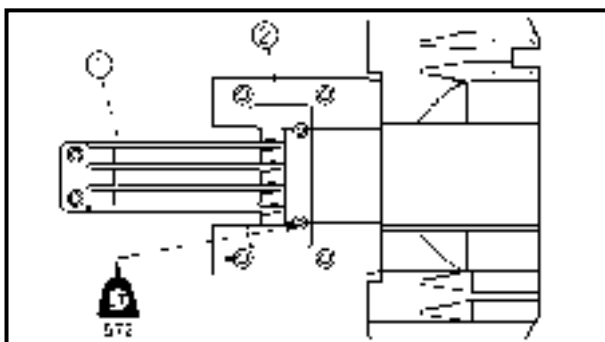

Max. impeller-to-housing clearance:
0.6 mm (0.02 in)

Measurement steps:

- Remove the battery leads.
- Remove the intake grate ① and intake duct ②.
- Measure the clearance at each impeller blade as shown (a total of three measurements).
- Install the intake grate and intake duct.



Bolt:
M6: 7 N • m
(0.7 kgf • m, 5.1 ft • lb)
M8: 17 N • m
(1.7 kgf • m, 12 ft • lb)

- Install the battery leads.

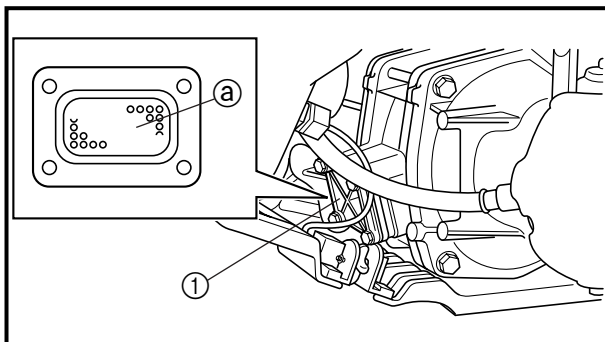

Water inlet strainer inspection

1. Inspect:
- Water inlet strainer
Contaminants → Clean.
Cracks/damage → Replace.

Inspection steps:

- Remove the water inlet cover ①.
- Inspect the water inlet strainer mesh ②.
- Install the water inlet cover.

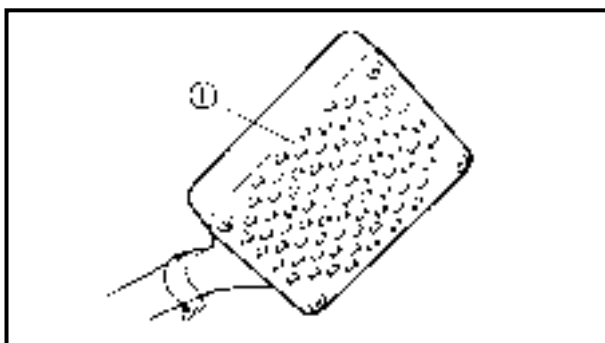

Bilge strainer inspection

1. Inspect:
- Bilge strainer
Contaminants → Clean.
Cracks/damage → Replace.

Inspection steps:

- Disconnect the bilge strainer ① from the bilge strainer holder.
- Inspect the bilge strainer.

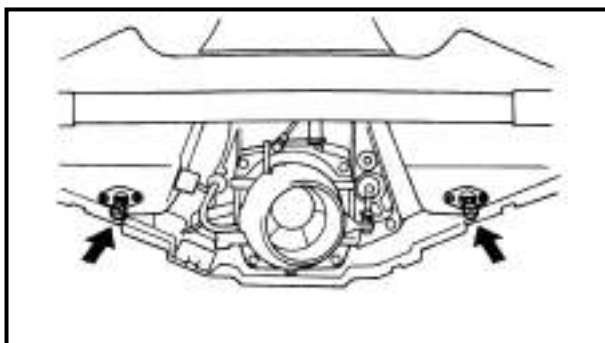
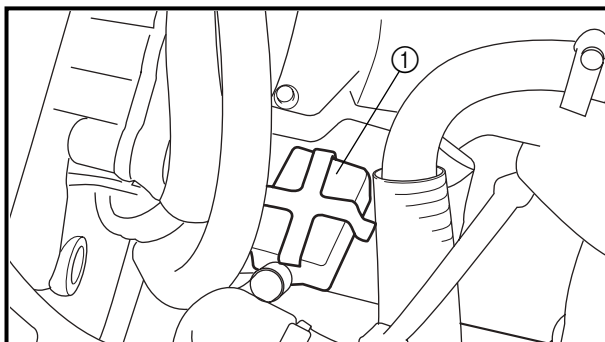

GENERAL

Drain plug inspection

1. Inspect:
- Drain plugs
Cracks/damage → Replace.
 - O-rings
Cracks/wear → Replace.
 - Screw threads
Contaminants → Clean.

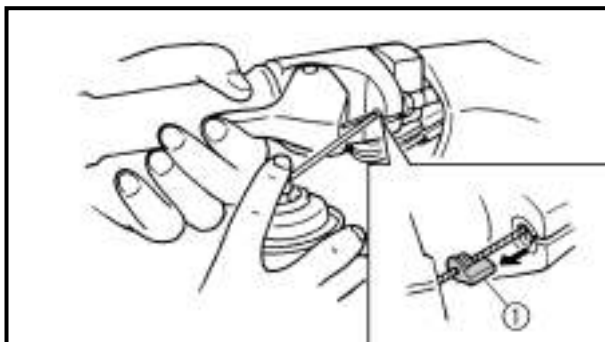

Lubrication points

1. Lubricate:
 - Throttle cable (handlebar side)



Recommended lubricant:
Rust inhibitor

NOTE:

Before lubricating the throttle cable, squeeze the throttle lever and remove the rubber seal ①.

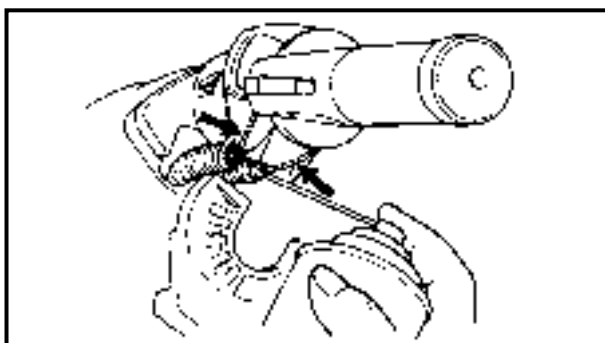

2. Lubricate:
 - QSTS control cables (handlebar side)



Recommended lubricant:
Yamaha marine grease,
Yamaha grease A
(Water resistant grease)

NOTE:

Before lubricating the QSTS control cables, remove the QSTS cable housing cover. Spray the rust inhibitor into the outer cables, and apply grease to the inner cables.

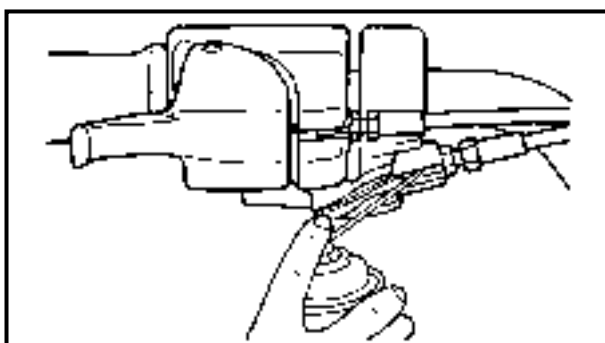

3. Lubricate:
 - Choke cable (handlebar side)



Recommended lubricant:
Rust inhibitor

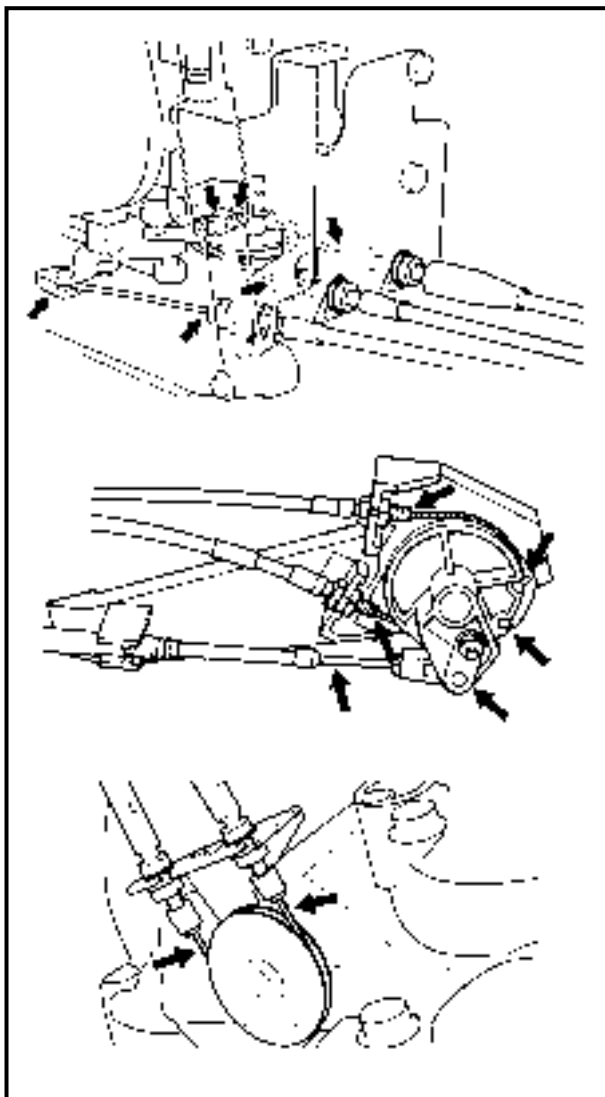

4. Lubricate:

- Throttle cable (carburetor side)
- Oil pump cable
- QSTS cables (pulley side)
- YPVS cables



Recommended grease:
Yamaha marine grease,
Yamaha grease A
(Water resistant grease)

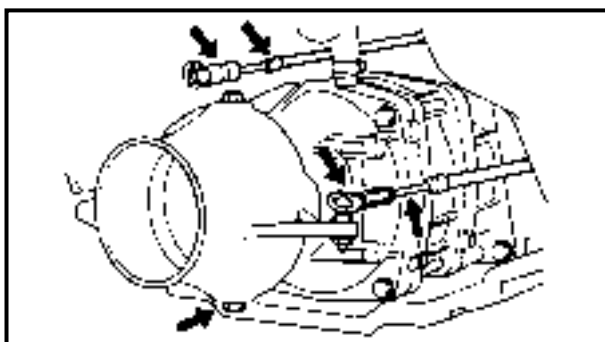

5. Lubricate:

- Nozzle pivot shaft
- Steering cable (nozzle side)
- QSTS cable (nozzle side)



Recommended grease:
Yamaha marine grease,
Yamaha grease A
(Water resistant grease)

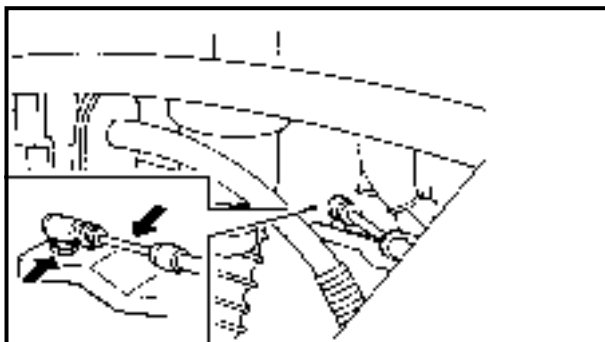

6. Lubricate:

- Steering cable
- Steering cable joint

NOTE: _____

Disconnect the joints and apply a small amount of grease.



Recommended grease:
Yamaha marine grease,
Yamaha grease A
(Water resistant grease)

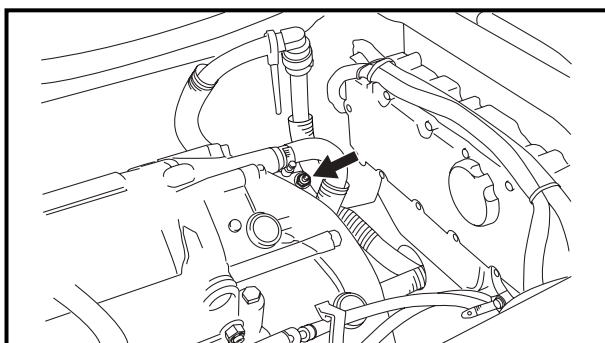

7. Fill:

- Intermediate housing



Recommended grease:
Yamaha marine grease,
Yamaha grease A
(Water resistant grease)

NOTE: _____

Fill the intermediate housing with the recommended grease through the grease nipples.

CHAPTER 4 FUEL SYSTEM

FUEL COCK AND FUEL FILTER	4-1
EXPLODED DIAGRAM	4-1
REMOVAL AND INSTALLATION CHART	4-1
SERVICE POINTS	4-2
Fuel filter inspection	4-2
Fuel cock inspection.....	4-2
 OIL TANK	 4-3
EXPLODED DIAGRAM	4-3
REMOVAL AND INSTALLATION CHART	4-3
SERVICE POINTS	4-5
Oil line inspection	4-5
Oil level sensor inspection	4-5
Oil tank inspection	4-5
 FUEL TANK	 4-6
EXPLODED DIAGRAM	4-6
REMOVAL AND INSTALLATION CHART	4-6
SERVICE POINTS	4-9
Check valve inspection	4-9
Fuel level sensor inspection.....	4-9
Fuel tank inspection	4-9
Pipe joint inspection	4-9
 INTAKE SILENCER	 4-10
EXPLODED DIAGRAM	4-10
REMOVAL AND INSTALLATION CHART	4-10
 CARBURETOR UNIT	 4-11
EXPLODED DIAGRAM	4-11
REMOVAL AND INSTALLATION CHART	4-11
SERVICE POINTS	4-18
Throttle valve synchronization inspection and adjustment	4-18
Choke cable and throttle cable installation.....	4-19
Oil pump cable installation	4-19
Carburetor assembly	4-19

CARBURETOR 4-20
 EXPLODED DIAGRAM 4-20
 REMOVAL AND INSTALLATION CHART 4-20
 SERVICE POINTS 4-23
 Diaphragm inspection 4-23
 Accelerator pump body inspection 4-23
 Arm inspection 4-23
 Regulator body inspection 4-24
 Needle valve inspection 4-24
 Jet and carburetor body inspection 4-24
 Carburetor assembly 4-24

FUEL PUMP 4-25
 EXPLODED DIAGRAM 4-25
 REMOVAL AND INSTALLATION CHART 4-25
 SERVICE POINTS 4-27
 Fuel pump inspection 4-27
 Fuel filter inspection 4-27

OIL PUMP 4-28
 EXPLODED DIAGRAM 4-28
 REMOVAL AND INSTALLATION CHART 4-28
 SERVICE POINTS 4-30
 Oil pump inspection 4-30
 Oil hose inspection 4-30
 Check valve inspection 4-30
 Oil pump cable adjustment 4-30
 Oil injection pump air bleeding 4-31



**FUEL COCK AND FUEL FILTER
EXPLODED DIAGRAM**

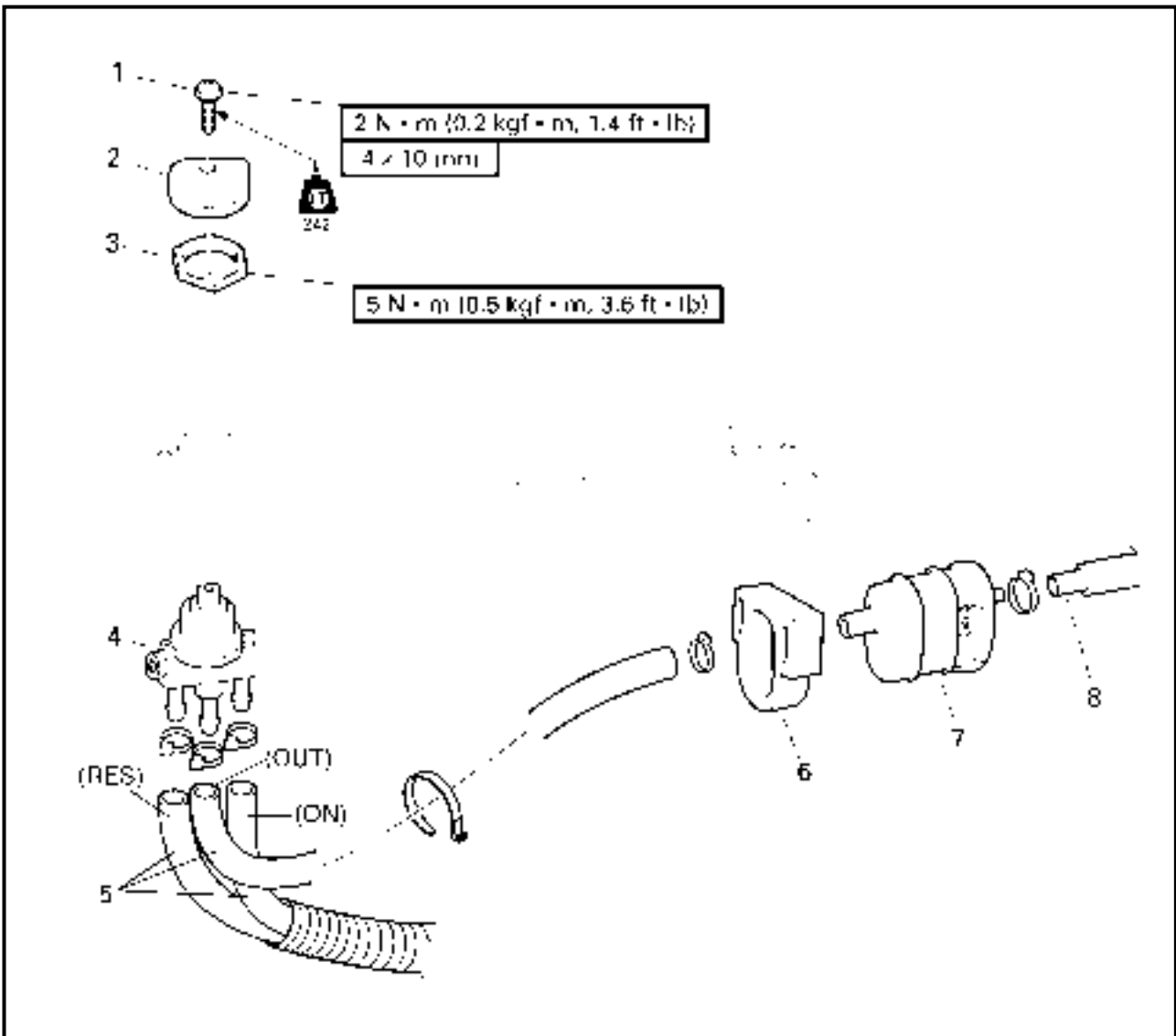

REMOVAL AND INSTALLATION CHART

Step	Procedure/Part name	Q'ty	Service points
	FUEL COCK AND FUEL FILTER REMOVAL		Follow the left "Step" for removal.
1	Screw	1	
2	Knob	1	
3	Nut	1	
4	Fuel cock assembly	1	
5	Fuel hose	3	
6	Holder	1	
7	Fuel filter	1	
8	Fuel hose	1	
			Reverse the removal steps for installation.



SERVICE POINTS

Fuel filter inspection

Refer to "FUEL SYSTEM" in chapter 3.

Fuel cock inspection

1. Check:

- Fuel cock
 - Contaminants → Clean.
 - Rough movement → Replace.

**OIL TANK
EXPLODED DIAGRAM**

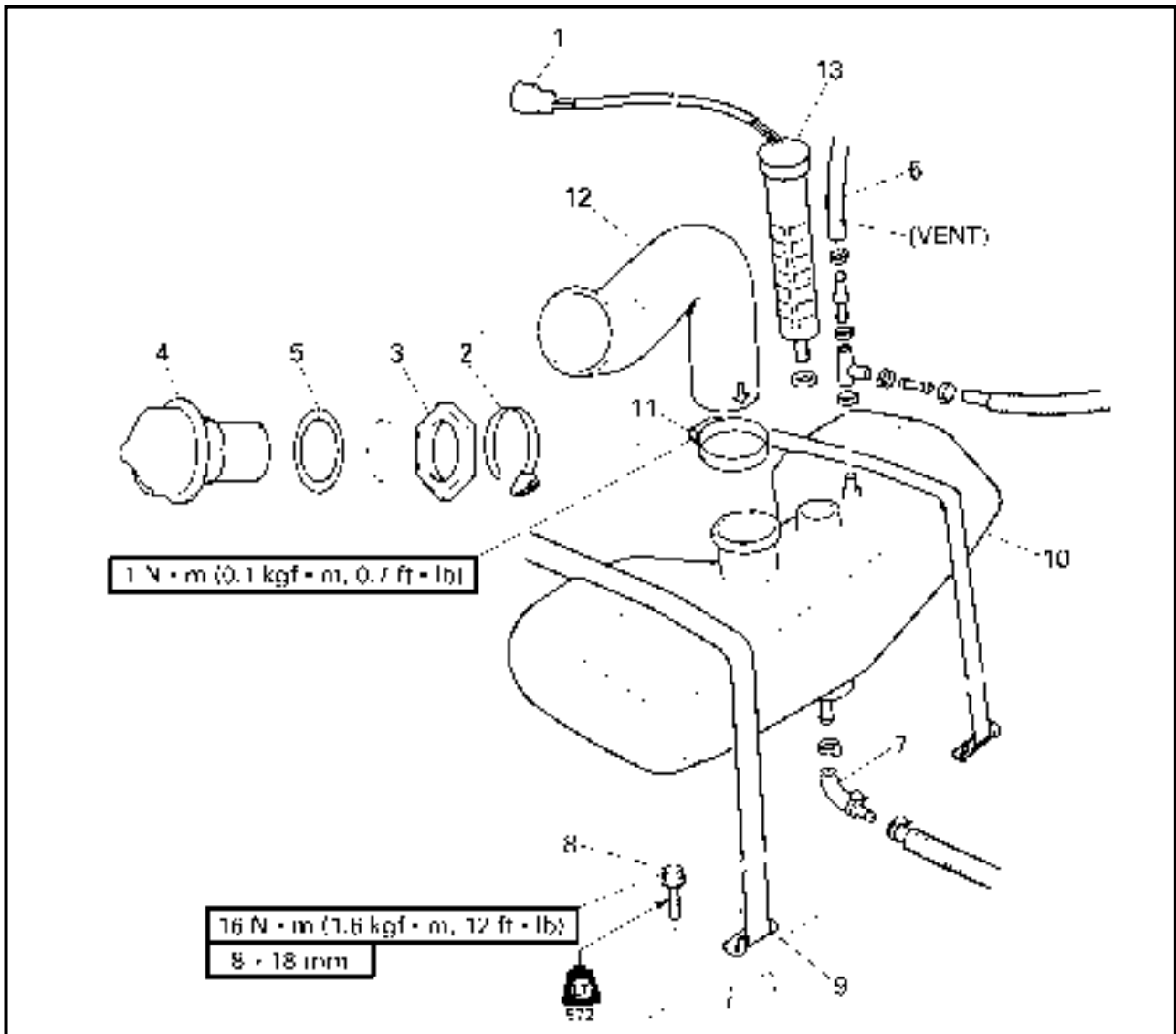

REMOVAL AND INSTALLATION CHART

Step	Procedure/Part name	Q'ty	Service points
	OIL TANK REMOVAL		
	Engine unit		Follow the left "Step" for removal.
	Steering console cover assembly		Refer to "ENGINE UNIT" in chapter 5.
			Refer to "STEERING CONSOLE COVER" in chapter 8.
1	Oil level sensor coupler	1	
2	Band	1	Not reusable
			Disconnect the oil filler hose from the oil filler neck.
3	Nut	1	
4	Oil filler neck	1	
5	Rubber seal	1	



EXPLODED DIAGRAM

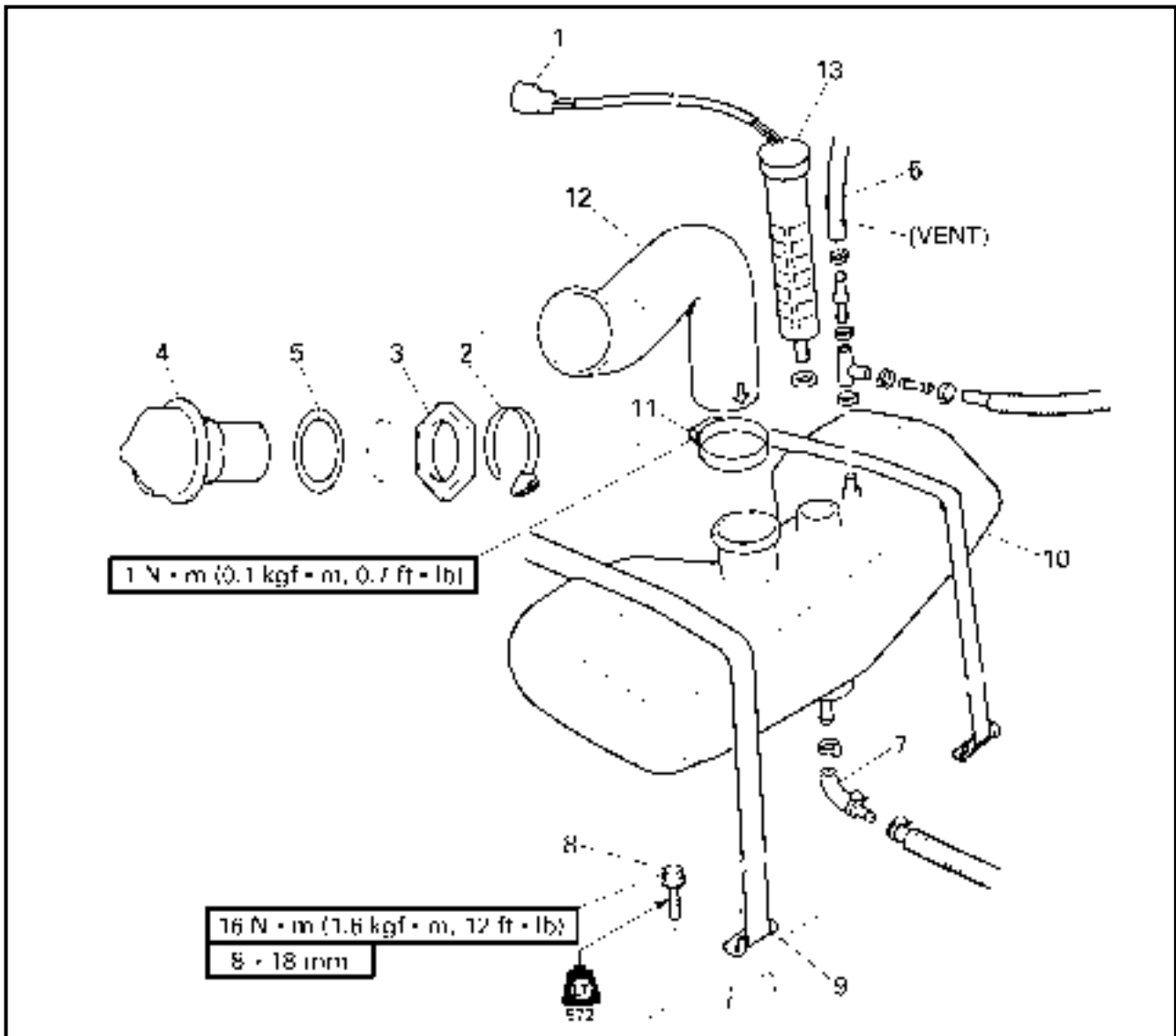

Step	Procedure/Part name	Q'ty	Service points
6	Breather hose	1	Reverse the removal steps for installation.
7	Oil hose	1	
8	Bolt	2	
9	Tank belt	2	
10	Oil tank assembly	1	
11	Hose clamp	1	
12	Oil filler hose	1	
13	Oil level sensor	1	



SERVICE POINTS

Oil line inspection

1. Inspect:

- Oil filter
Contaminants → Clean.
Frays/tears → Replace.
- Rubber seal
Cracks/wear → Replace.
- Oil hoses
- Oil tank
- Oil filler cap
Cracks/damage → Replace.
- Check valve
Malfunction → Replace.

Oil level sensor inspection

Refer to "INDICATION SYSTEM" in chapter 7.

Oil tank inspection

1. Inspect:

- Oil tank
Cracks/damage → Replace.



**FUEL TANK
EXPLODED DIAGRAM**

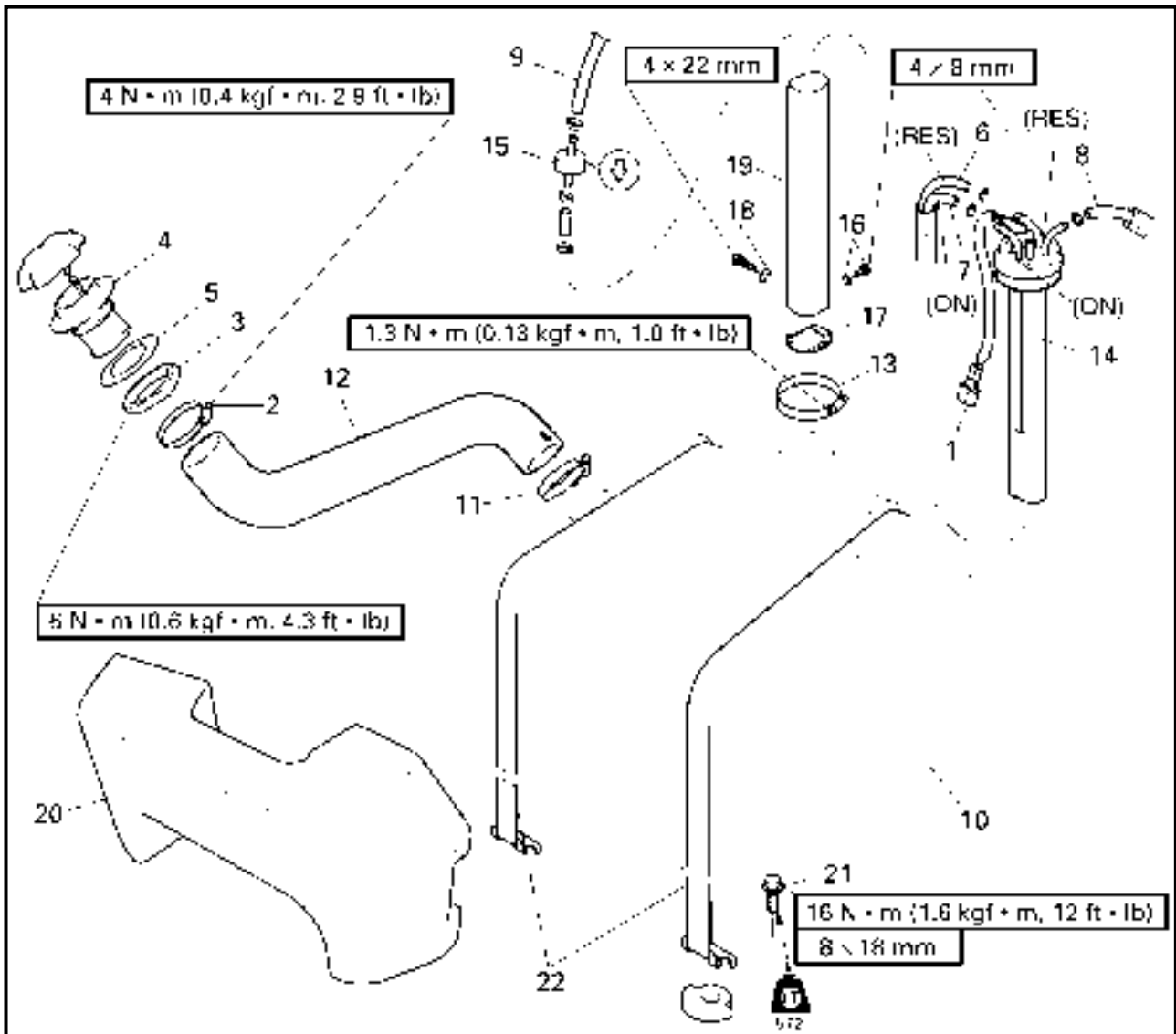

REMOVAL AND INSTALLATION CHART

Step	Procedure/Part name	Q'ty	Service points
	FUEL TANK REMOVAL		
	Oil tank		Follow the left "Step" for removal. Refer to "OIL TANK".
1	Fuel level sensor coupler	1	
2	Hose clamp	1	Disconnect the fuel filler hose from the fuel filler neck.
3	Nut	1	
4	Fuel filler neck	1	
5	Rubber seal	1	
6	Fuel reserve hose	1	



EXPLODED DIAGRAM

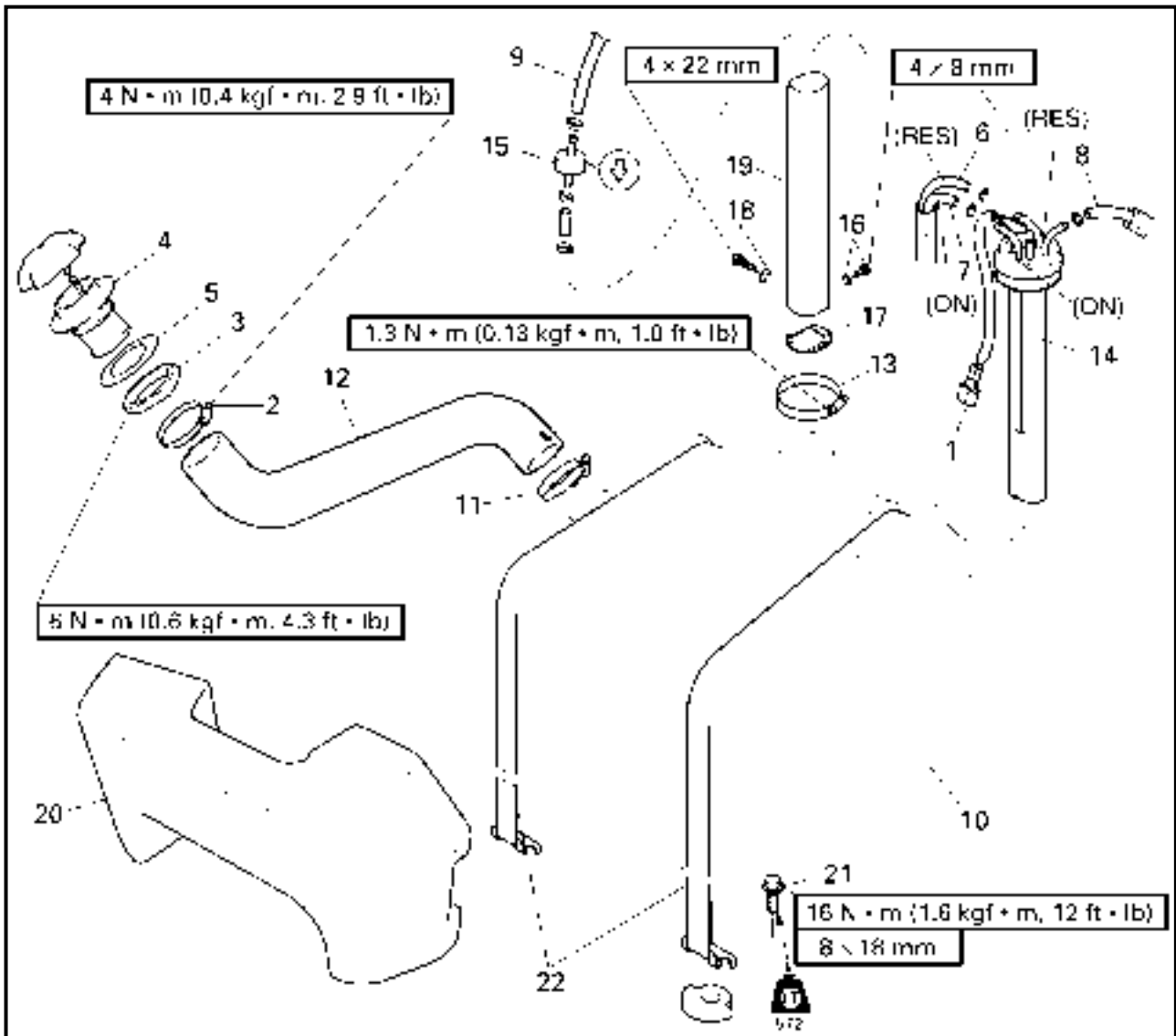

Step	Procedure/Part name	Q'ty	Service points
7	Fuel hose	1	
8	Fuel return hose	1	
9	Fuel tank breather hose	1	
10	Fuel tank assembly	1	
11	Hose clamp	1	
12	Fuel filler hose	1	
13	Hose clamp	1	
14	Fuel sensor assembly	1	



EXPLODED DIAGRAM

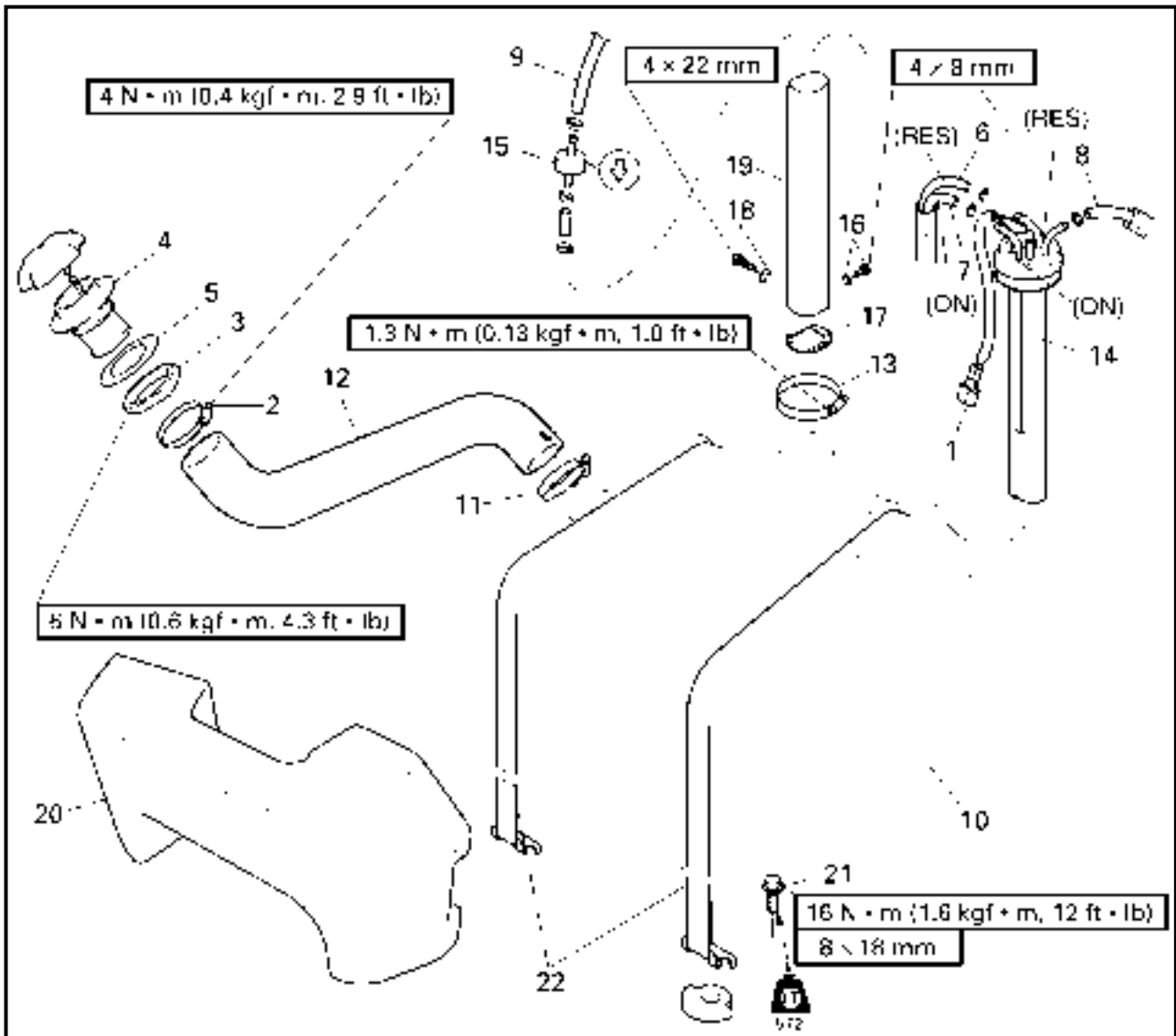

Step	Procedure/Part name	Q'ty	Service points
15	One way valve	1	
16	Screw/washer	1/1	
17	Filter	1	
18	Screw/washer	1/1	
19	Sleeve	1	
20	Floation	1	
21	Bolt	2	
22	Tank belt	2	
			Reverse the removal steps for installation.

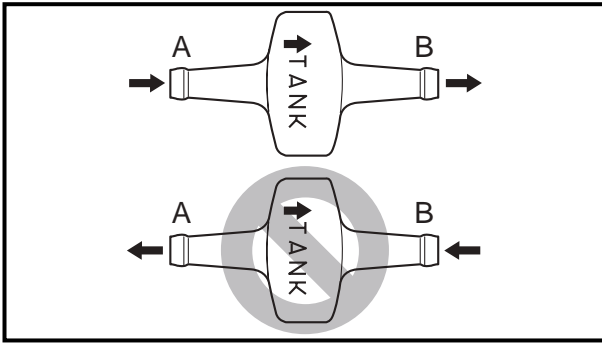

SERVICE POINTS

Check valve inspection

1. Check:

- Check valve
Faulty → Replace.

Checking steps:

- Connect a hose to the end of check valve "A" and blow into it.
Air should come out from end "B".
- Connect the hose to the end of check valve "B" and blow into it.
Air should not come out from end "A".

Fuel level sensor inspection

Refer to "INDICATION SYSTEM" in chapter 7.

Fuel tank inspection

1. Inspect:

- Fuel tank
Cracks/damage → Replace.

Pipe joint inspection

1. Inspect:

- Pipe
Contaminants → Clean.
Bends/damage → Replace.

**INTAKE SILENCER
EXPLODED DIAGRAM**

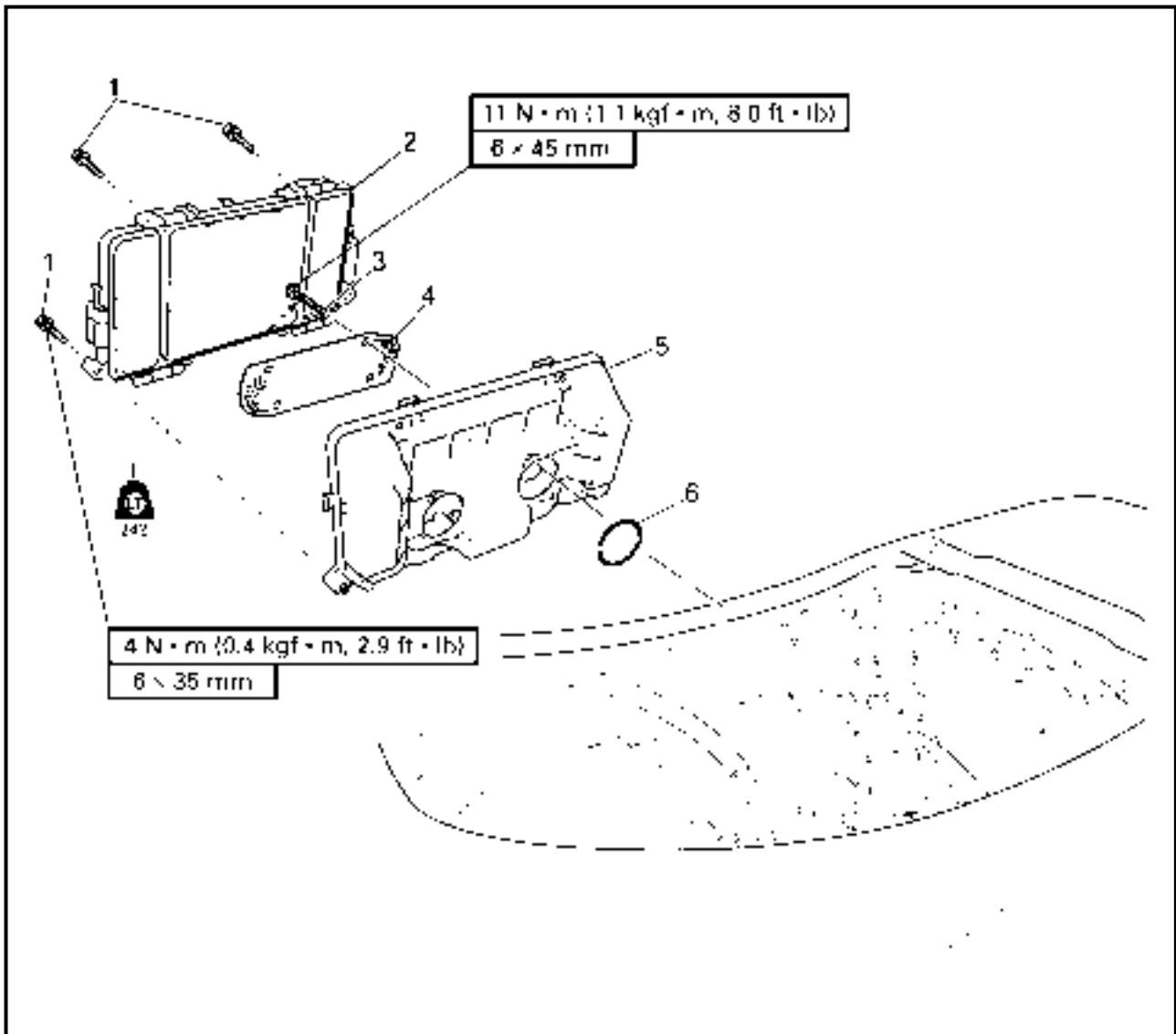

REMOVAL AND INSTALLATION CHART

Step	Procedure/Part name	Q'ty	Service points
INTAKE SILENCER REMOVAL			Follow the left "Step" for removal.
1	Bolt	3	
2	Intake silencer cover	1	
3	Bolt	4	
4	Spark arrester	1	
5	Intake silencer	1	
6	O-ring	2	Reverse the removal steps for installation.



**CARBURETOR UNIT
EXPLODED DIAGRAM**

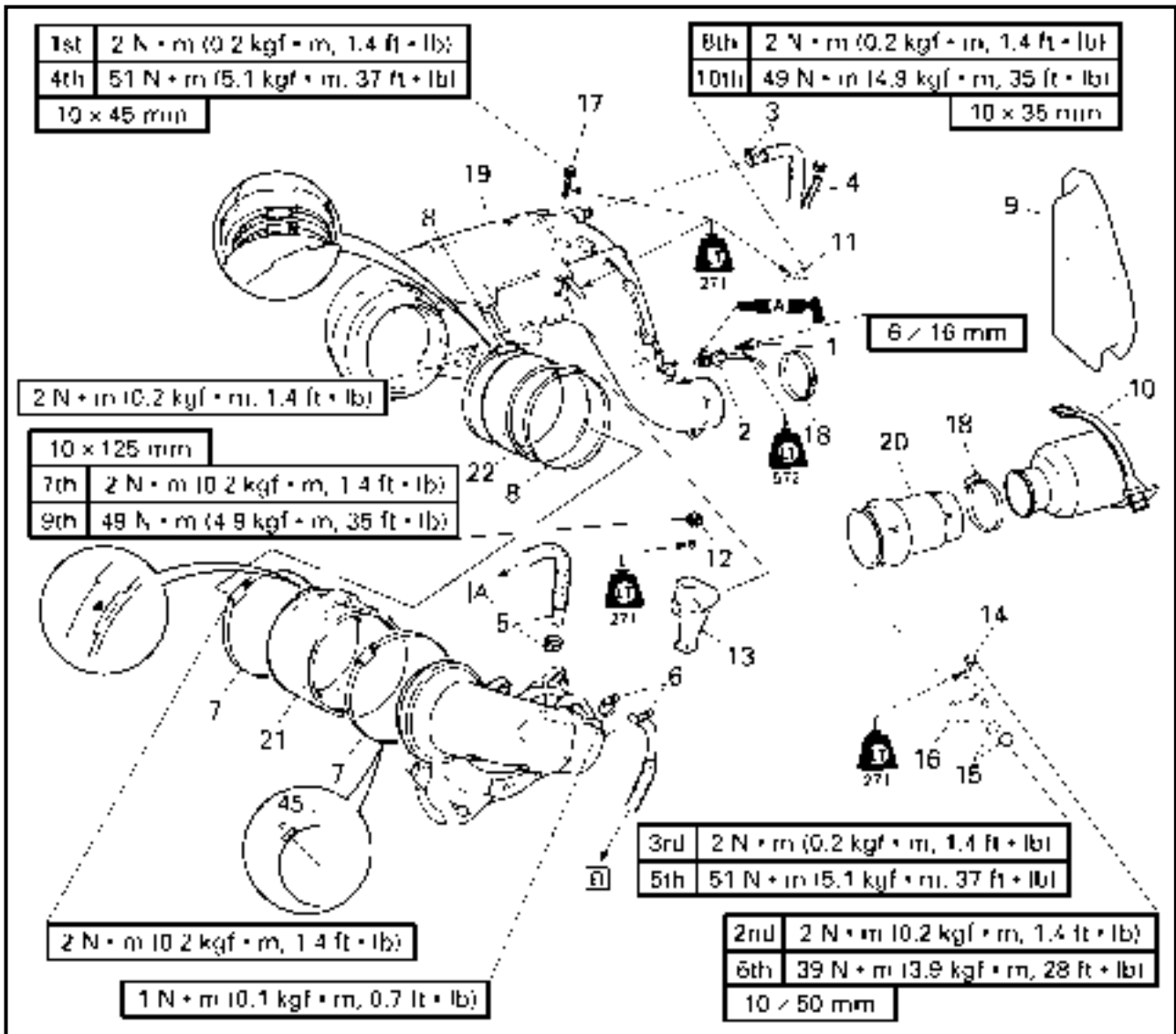

REMOVAL AND INSTALLATION CHART

Step	Procedure/Part name	Q'ty	Service points	
	CARBURETOR REMOVAL			
	Battery box		Follow the left "Step" for removal. Refer to "BATTERY BOX" in chapter 8.	
	Intake silencer		Refer to "INTAKE SILENCER".	
1	Bolt	2	NOTE: _____ When removing the carburetor, the exhaust chamber assembly does not need to be removed if the engine unit has already been removed.	
2	Thermoswitch	1		
3	Clamp/cooling water hose	1/1		
4	Grease hose	1		
5	Clamp/cooling water hose	1/1		A For cooling water pilot outlet on starboard side
6	Clamp/cooling water hose	1/1		B For cooling water pilot outlet on port side



EXPLODED DIAGRAM

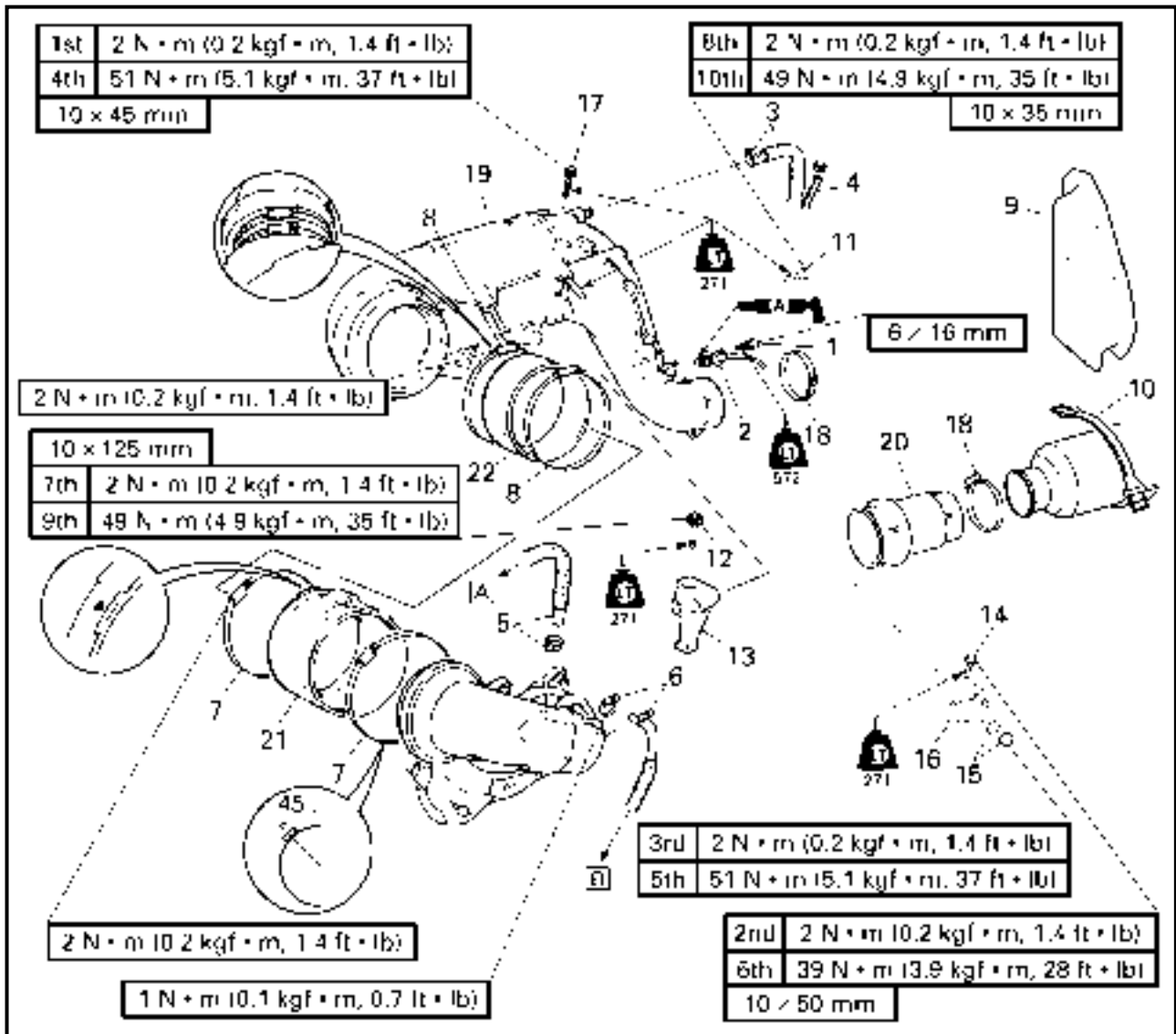

Step	Procedure/Part name	Q'ty	Service points
7	Hose clamp	2	Slide the outer exhaust joint.
8	Hose clamp	2	
9	Flootation	1	
10	Water lock band	1	
11	Bolt	1	
12	Bolt	1	
13	Muffler stay 3	1	
14	Bolt	4	
15	Nut/washer	2/2	



EXPLODED DIAGRAM

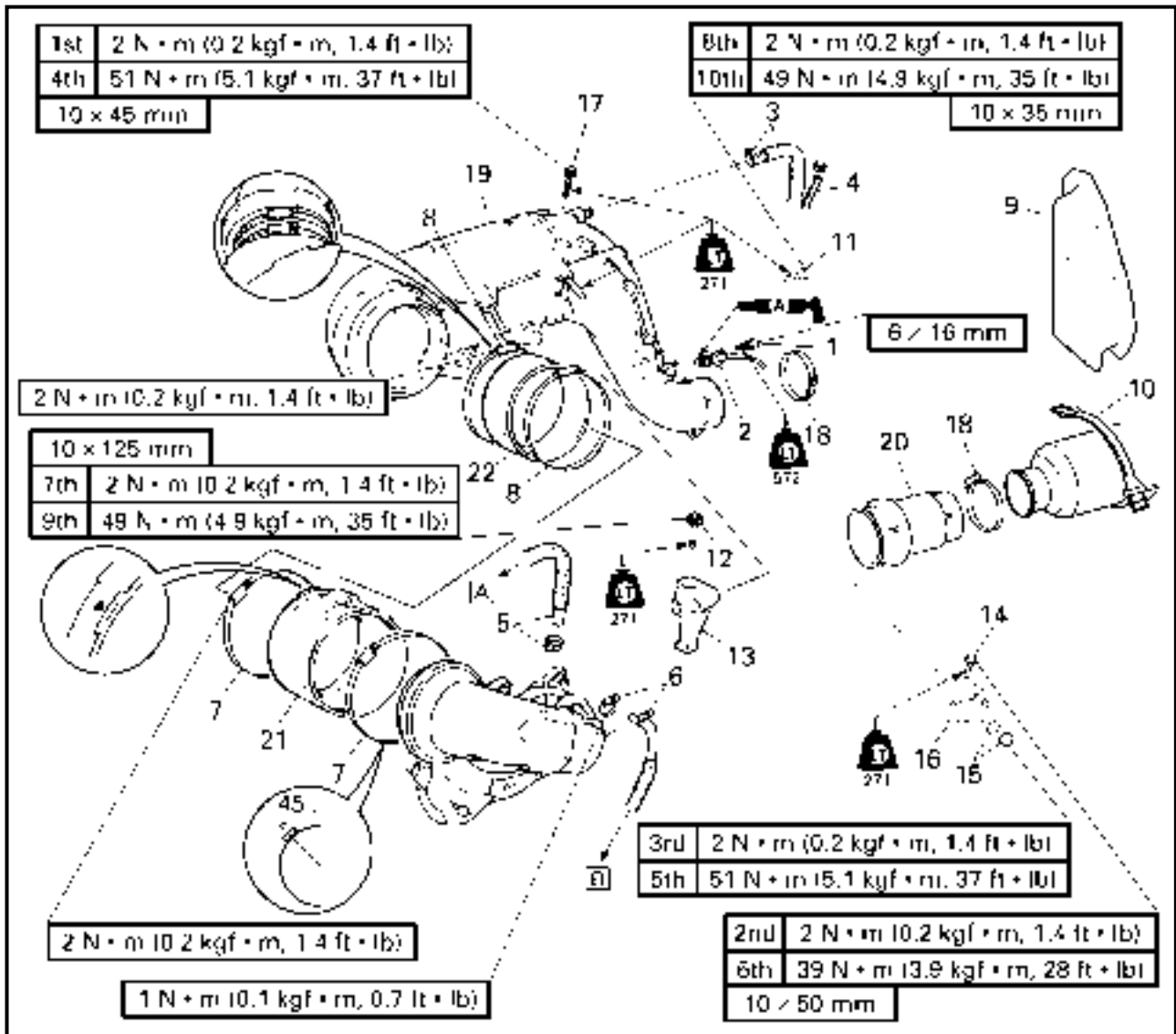

Step	Procedure/Part name	Q'ty	Service points
16	Muffler stay 1	2	NOTE: _____ Make sure to remove spark plugs before removing the muffler stay 1.
17	Bolt	2	
18	Hose clamp	2	
19	Exhaust chamber assembly	1	
20	Rubber joint	1	Slide the water lock to back
21	Outer exhaust joint	1	
22	Inner exhaust joint	1	



EXPLODED DIAGRAM

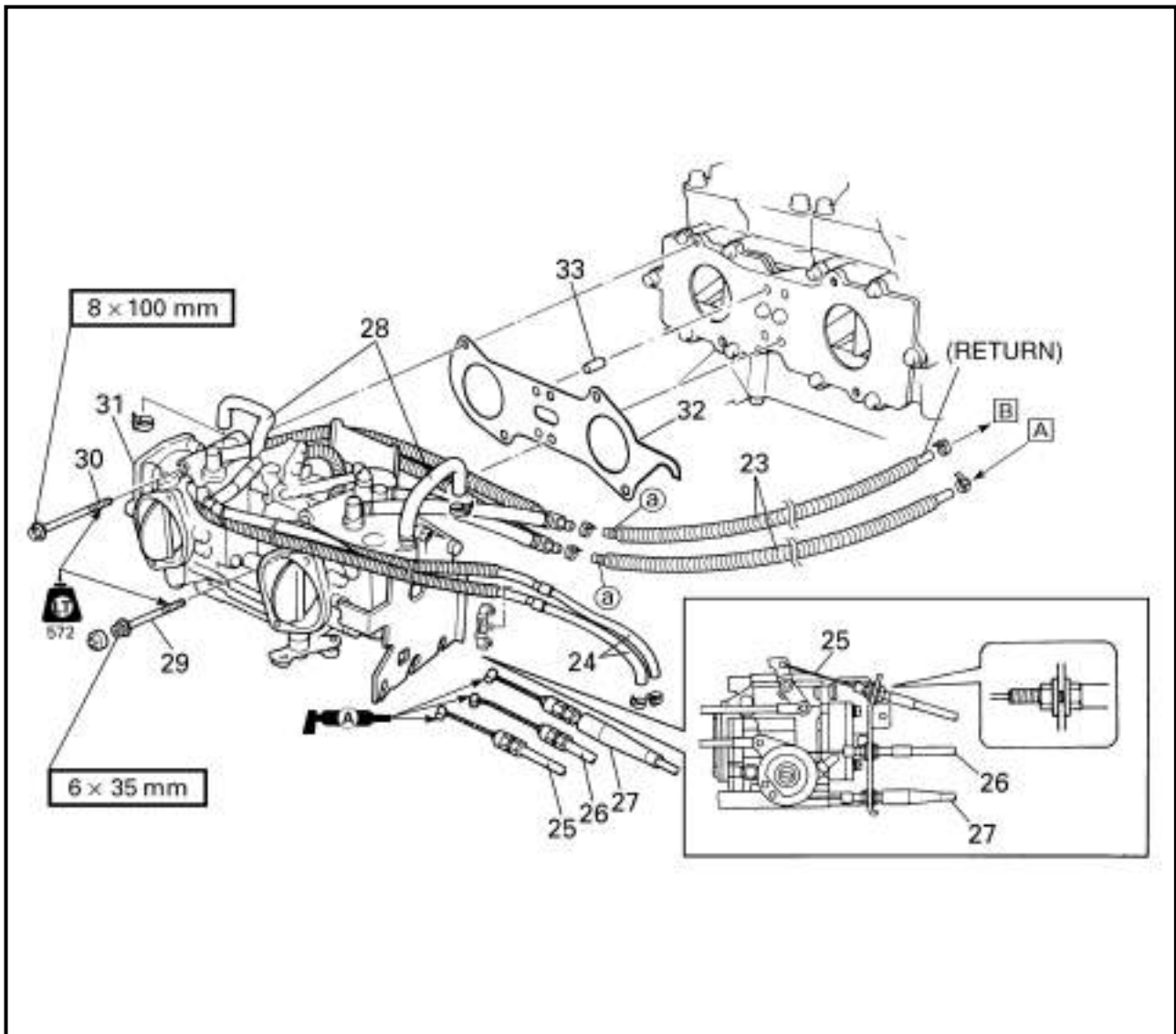

Step	Procedure/Part name	Q'ty	Service points
23	Fuel hose	2	[A] suction [B] return NOTE: _____ Use the white marks ® on the fuel hoses to distinguish the hose ends. _____
24	Oil feed hose	2	
25	Choke cable	1	
26	Throttle cable	1	
27	Oil pump cable	1	



EXPLODED DIAGRAM

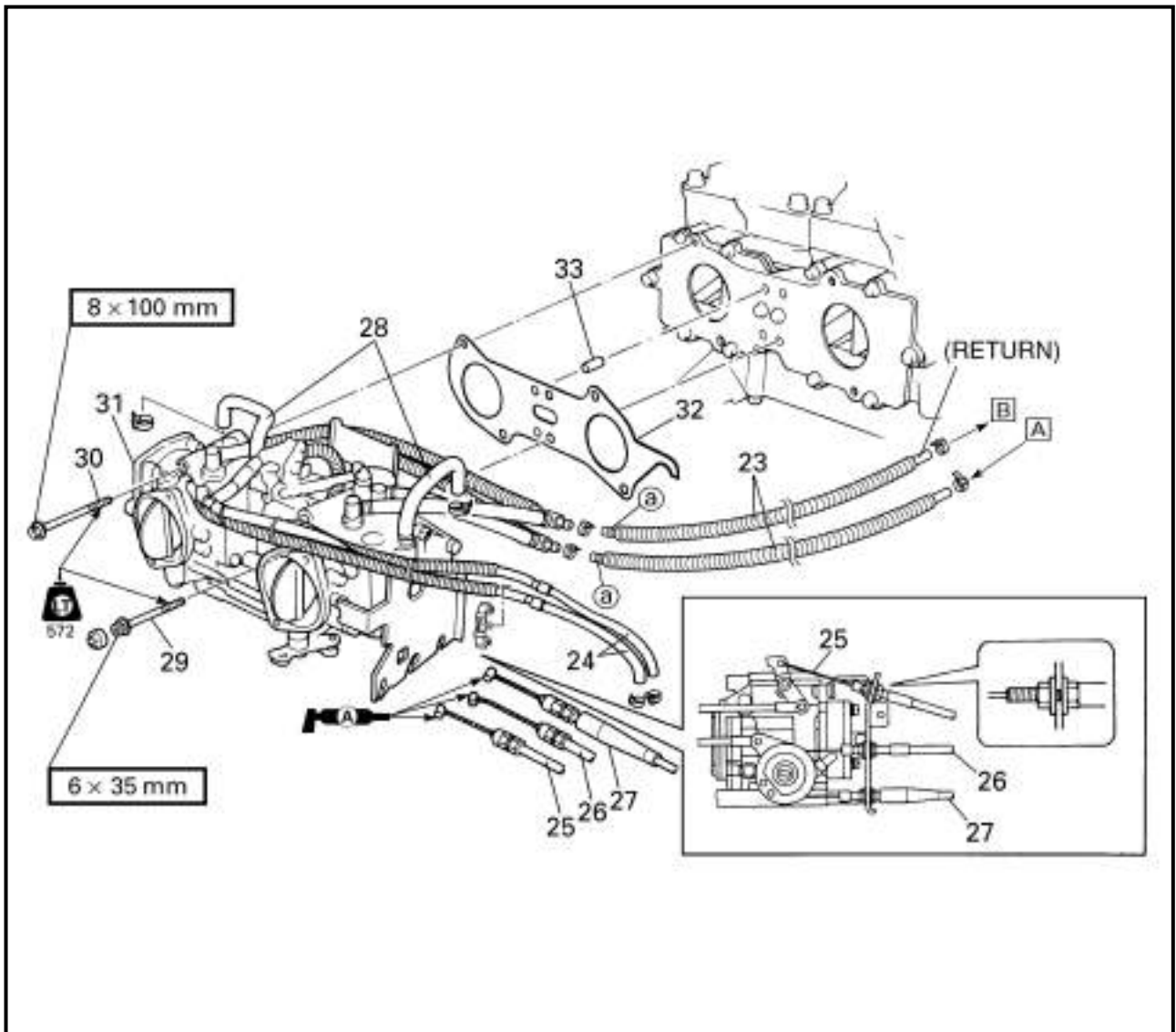

Step	Procedure/Part name	Q'ty	Service points
28	Pulse hose	2	<p>Not reusable</p> <p>Reverse the removal steps for installation.</p>
29	Bolt	2	
30	Bolt	4	
31	Carburetor unit	1	
32	Gasket	1	
33	Dowel pin	2	



EXPLODED DIAGRAM

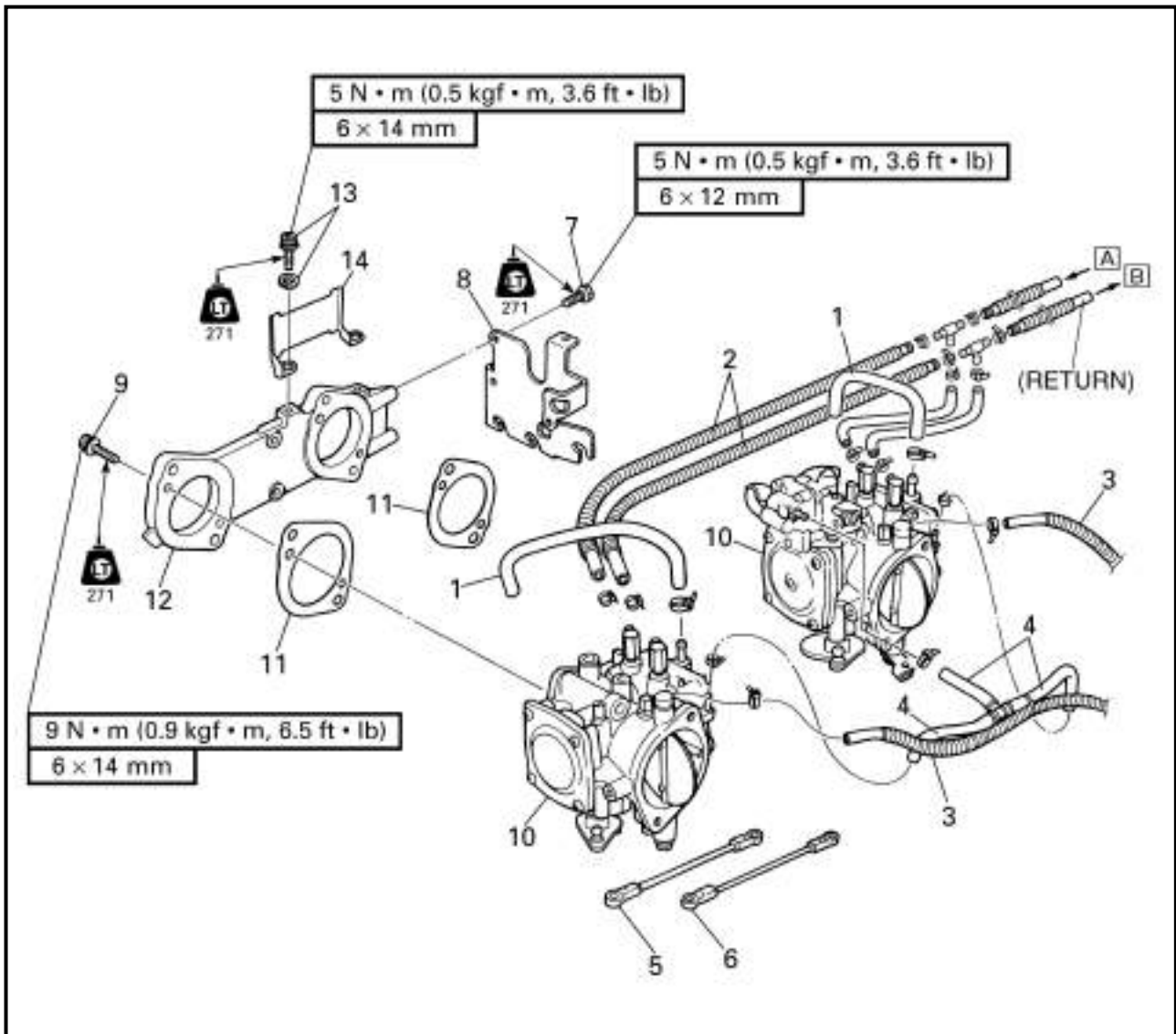

REMOVAL AND INSTALLATION CHART

Step	Procedure/Part name	Q'ty	Service points
	CARBURETOR UNIT SEPARATION		Follow the left "Step" for removal.
1	Pulse hose	2	
2	Fuel hose	4	<div style="display: flex; align-items: center;"> <div style="border: 1px solid black; padding: 2px; margin-right: 5px;">A</div> suction <div style="border: 1px solid black; padding: 2px; margin-left: 10px; margin-right: 5px;">B</div> return </div>
3	Oil feed hose	2	
4	Accelerator pump fuel hose	3	
5	Throttle link	1	
6	Choke link	1	



EXPLODED DIAGRAM

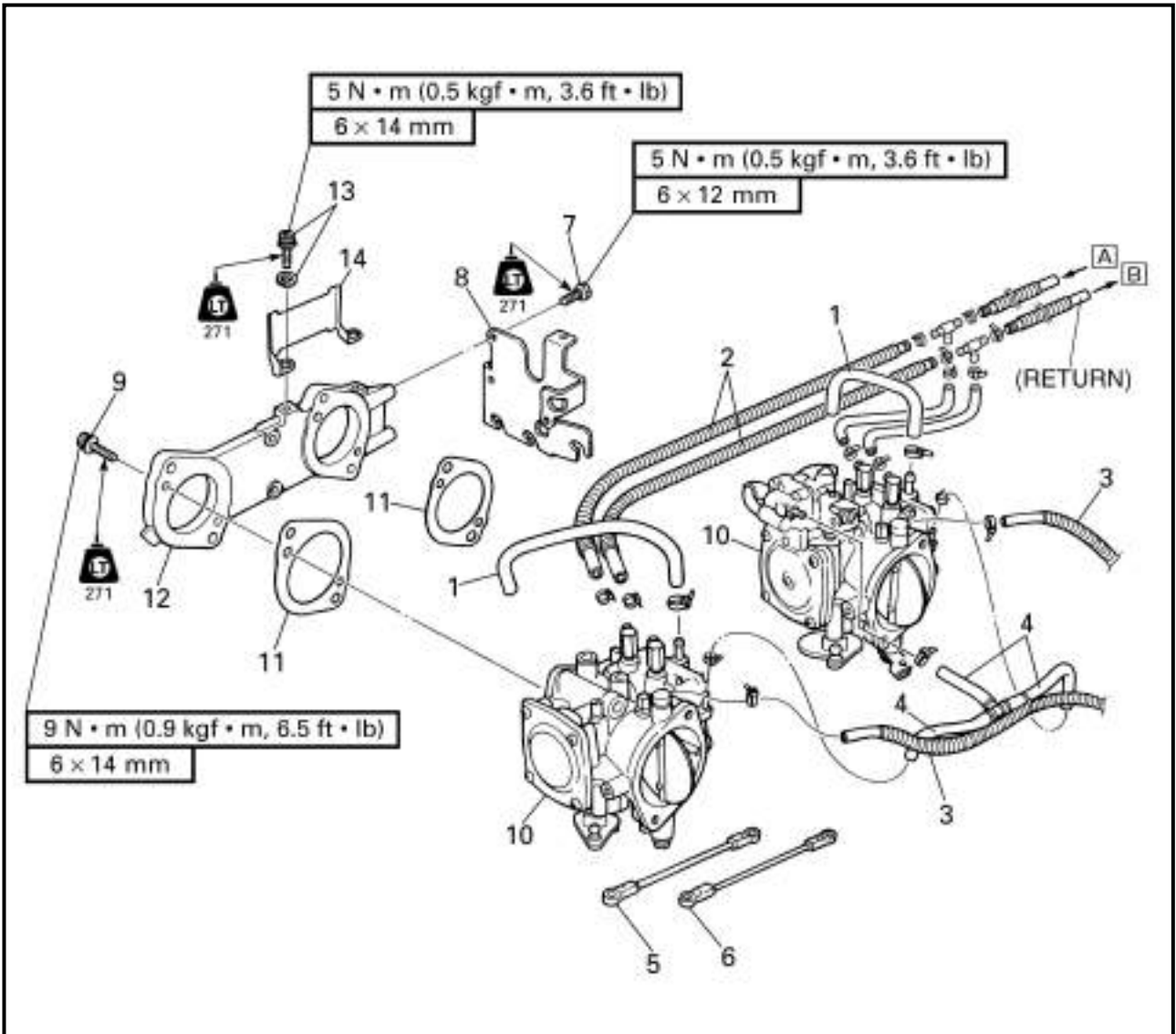

Step	Procedure/Part name	Q'ty	Service points
7	Bolt	3	<p>Not reusable</p> <p>Reverse the removal steps for installation.</p>
8	Cable bracket	1	
9	Bolt	4	
10	Carburetor	2	
11	Gasket	2	
12	Carburetor joint	1	
13	Bolt/washer	2/2	
14	Fuel hose guide	1	

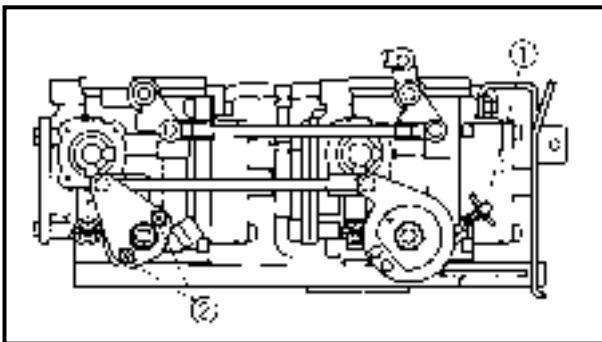
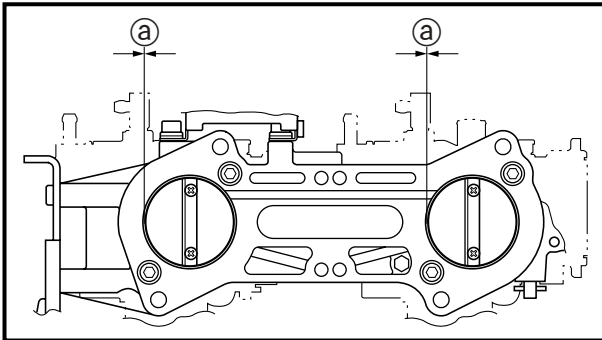
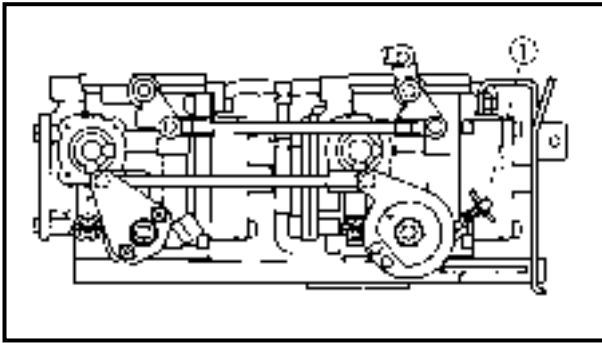

SERVICE POINTS

Throttle valve synchronization inspection and adjustment

1. Check:
 - Throttle valve synchronization
 - Different clearances → Adjust.

Checking steps:

- Loosen the throttle stop screw ① until untouched the screw end from the throttle lever.
- Check the each throttle valve is fully closed ②.

2. Adjust:

- Throttle valve synchronization

Adjustment steps:

- Loosen the throttle stop screw ① until untouched the screw end from the throttle lever.
- Loosen the screws ②.

NOTE: _____
 Make sure that the throttle valves are in the fully closed position.

- Tighten the screws ②.



Screw:
 2 N • m (0.2 kgf • m, 1.4 ft • lb)

- Turn in the throttle stop screw to the original position.

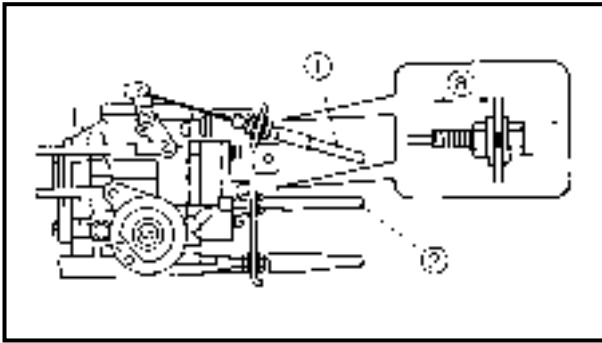

Choke cable and throttle cable installation

1. Install:

- Choke cable ①
- Throttle cable ②



Choke cable guide installation position ①:

13–15 mm (0.51–0.59 in)

Throttle cable guide installation position ②:

18–20 mm (0.71–0.79 in)

2. Adjust:

- Throttle lever free play
- Choke lever operation

Refer to “CONTROL SYSTEM” in chapter 3.

Oil pump cable installation

1. Adjust:

- Oil pump cable
- Refer to “OIL PUMP”.

Carburetor assembly

1. Adjust:

- Trolling speed

Refer to “FUEL SYSTEM” in chapter 3.



**CARBURETOR
EXPLODED DIAGRAM**

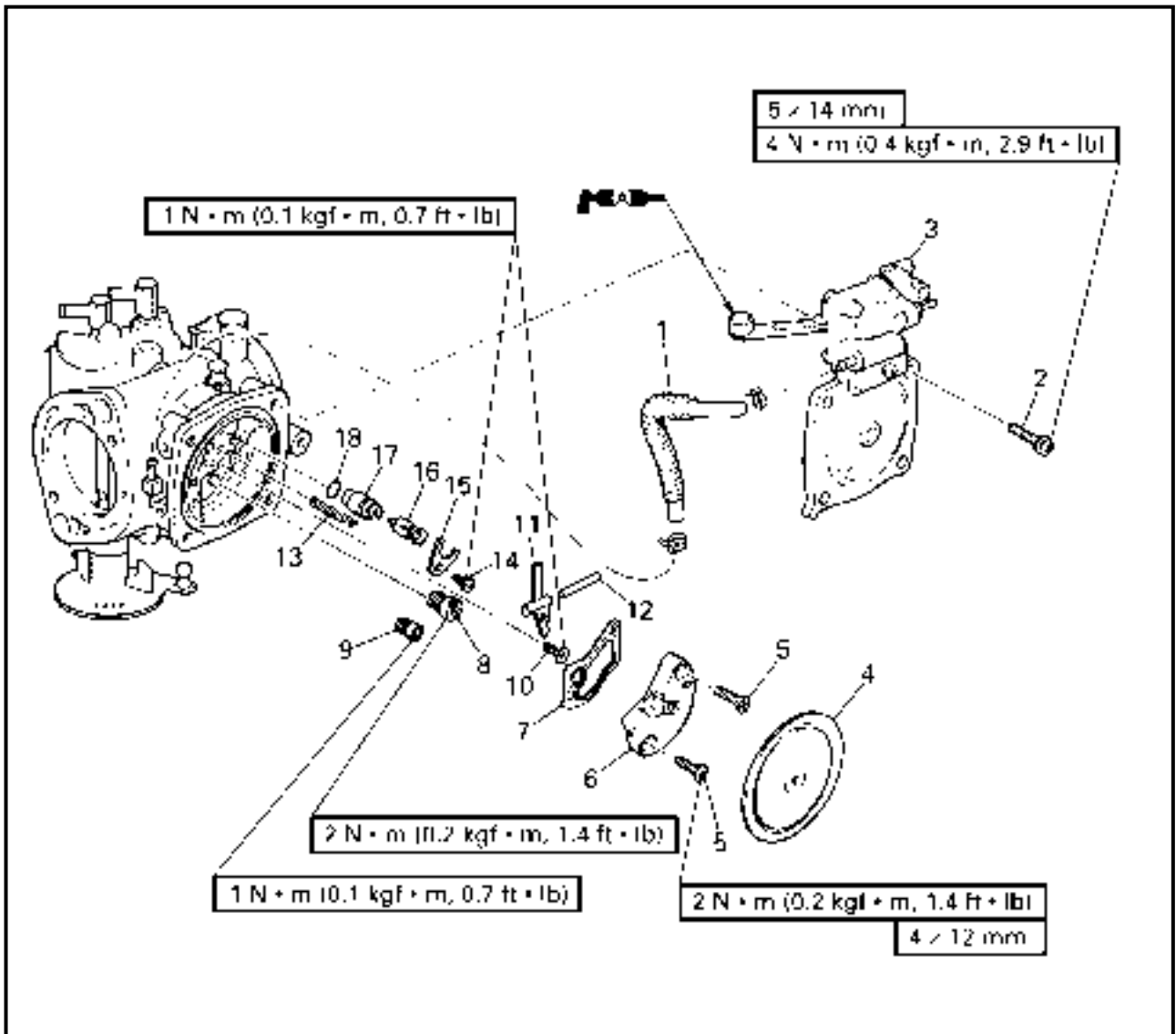

REMOVAL AND INSTALLATION CHART

Step	Procedure/Part name	Q'ty	Service points
CARBURETOR DISASSEMBLY			Follow the left "Step" for disassembly.
1	Accelerator pump fuel hose	1	Carburetor #1
2	Screw	4	
3	Accelerator pump/carburetor cover	1/1	Carburetor #1/carburetor #2
4	Diaphragm	1	
5	Screw	2	
6	Regulator body	1	
7	Gasket	1	
8	Main jet	1	
9	Pilot jet	1	



EXPLODED DIAGRAM

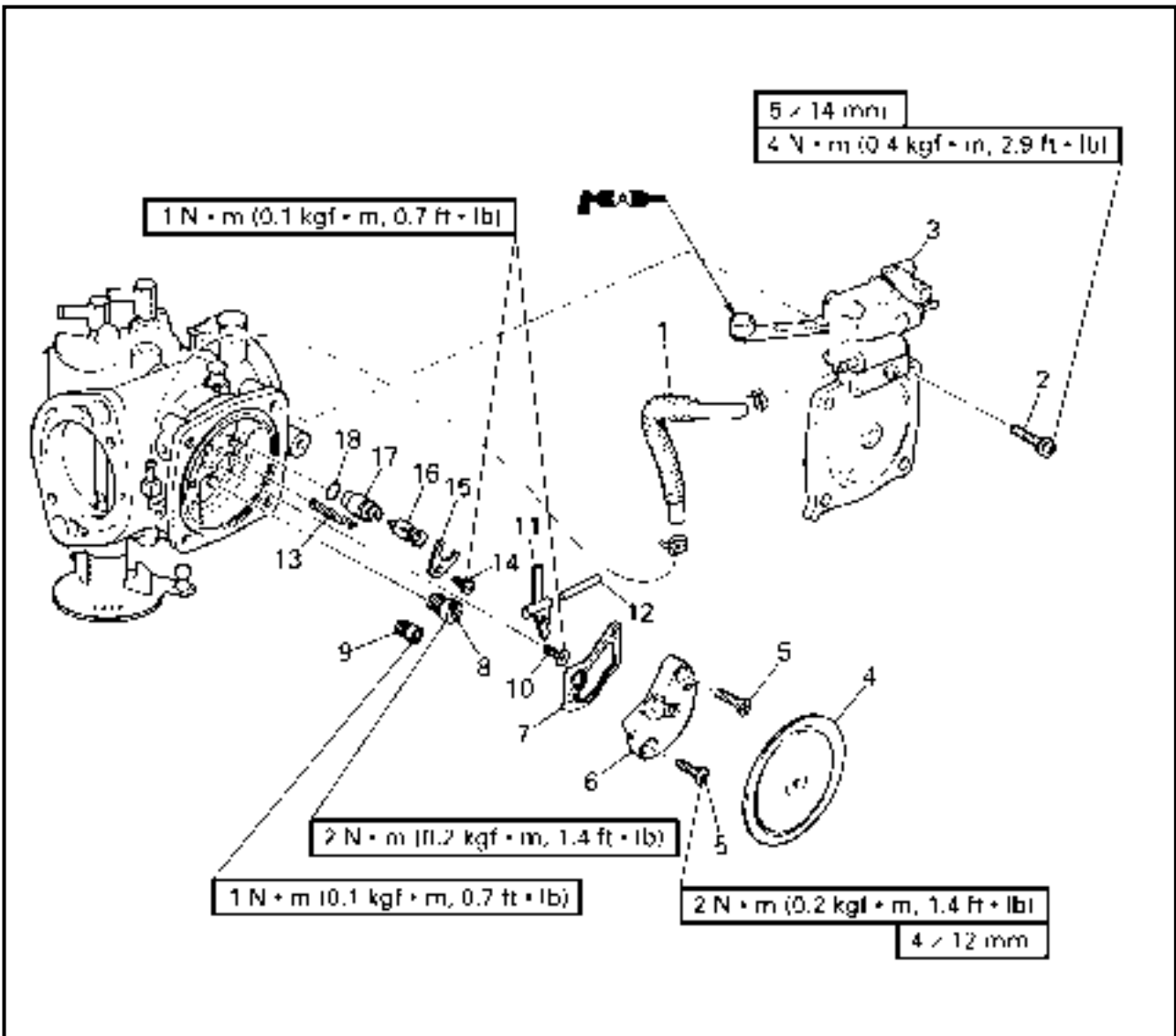

Step	Procedure/Part name	Q'ty	Service points
10	Screw	1	Reverse the disassembly steps for assembly.
11	Arm	1	
12	Arm pin	1	
13	Spring	1	
14	Screw	1	
15	Needle valve seat holder	1	
16	Needle valve	1	
17	Needle valve seat	1	
18	O-ring	1	



EXPLODED DIAGRAM

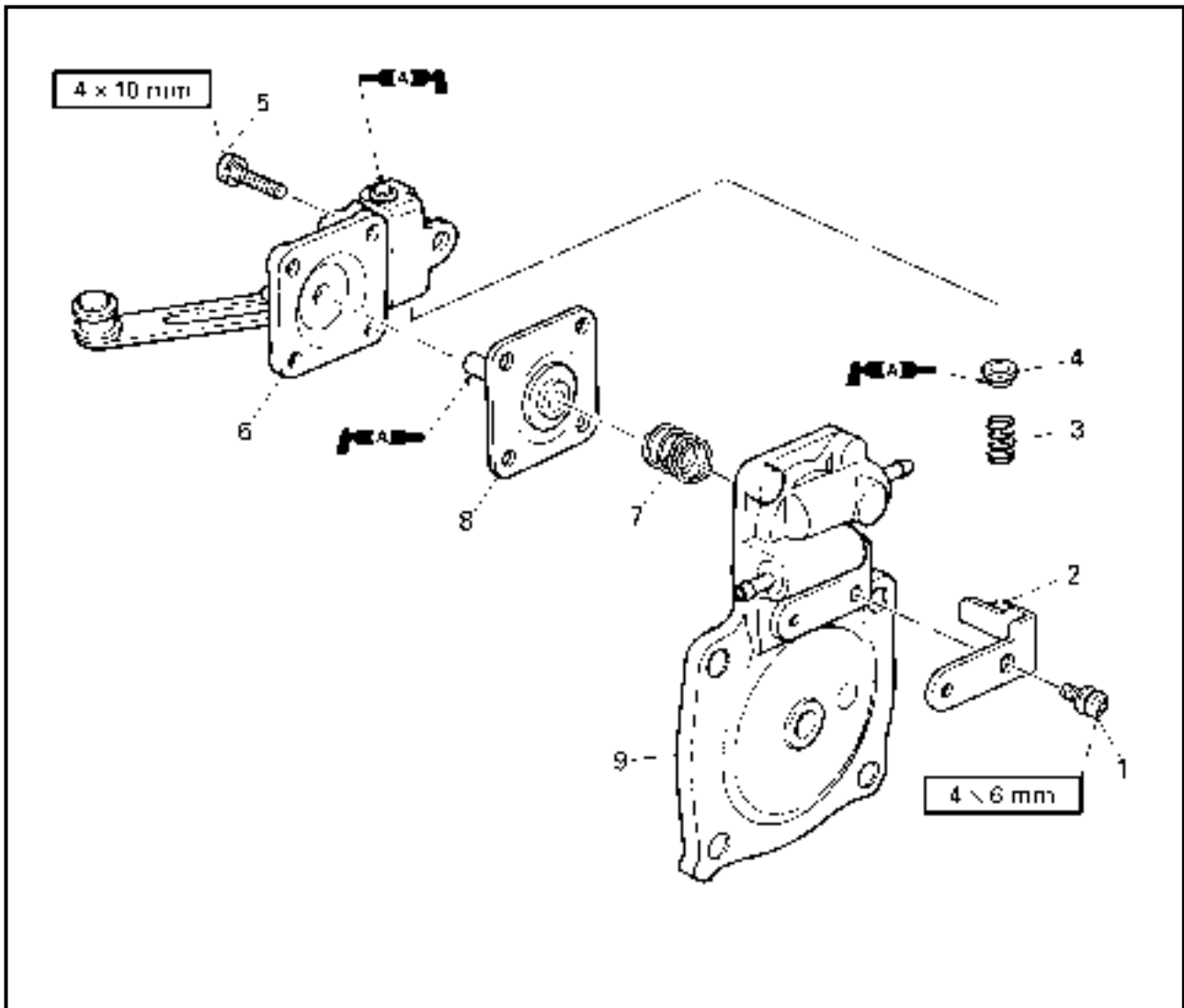

REMOVAL AND INSTALLATION CHART

Step	Procedure/Part name	Q'ty	Service points
	ACCELERATOR PUMP DISASSEMBLY		Follow the left "Step" for disassembly.
1	Screw	1	
2	Stay	1	
3	Spring	1	
4	Spring seat	1	
5	Screw	4	
6	Accelerator pump cover	1	
7	Spring	1	
8	Diaphragm	1	
9	Accelerator pump body	1	
			Reverse the disassembly steps for assembly.



SERVICE POINTS

NOTE:

Before disassembling the carburetor, make sure to note the number of times the pilot screw is turned in from its set position to the seated position.

CAUTION:

Do not use steel wire for cleaning the jets. This may enlarge the jet diameters and seriously affect performance.

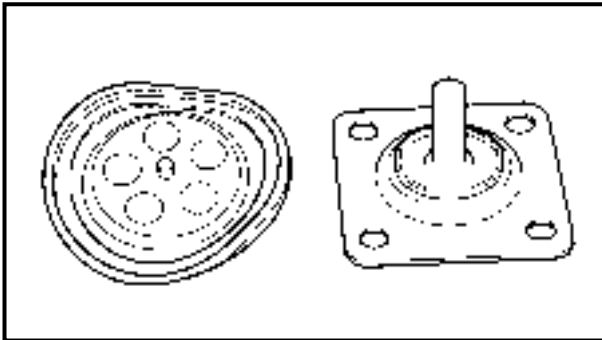

Diaphragm inspection

1. Inspect:
 - Diaphragm
Damage → Replace.

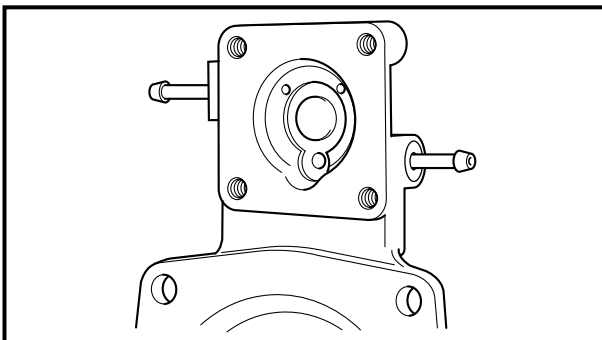

Accelerator pump body inspection

1. Inspect:
 - One way valve
Crack/damage → Replace the accelerator pump body.
 - Fuel passage
Clog → Clean or replace.

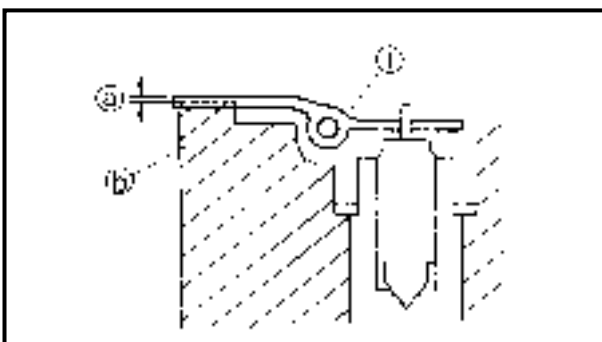

Arm inspection

1. Inspect:
 - Arm ①
Bends/damage → Repair or replace.
2. Measure:
 - Arm height ②

	Arm height: 0–0.2 mm (0–0.008 in)
--	---

NOTE:

- Measure the distance between the surface of the carburetor body ② and the top surface of the arm.
- The arm should be resting on the needle valve, but not compressing it.

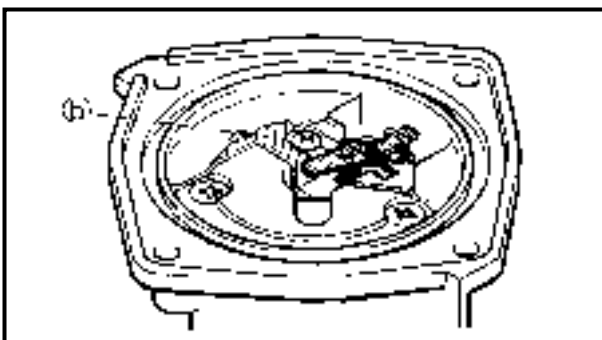

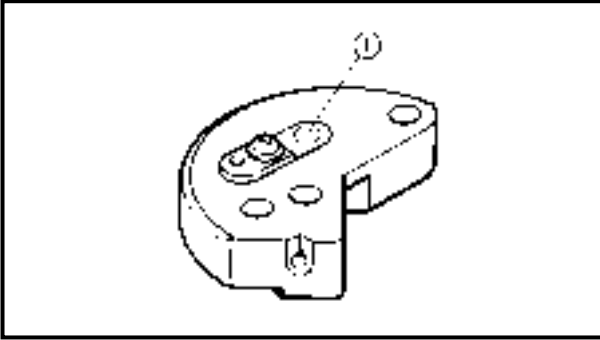

Regulator body inspection

1. Inspect:

- Regulator body
Contaminants → Clean.
Damage → Replace.
- Valve (clear film) ①
Damage → Replace.

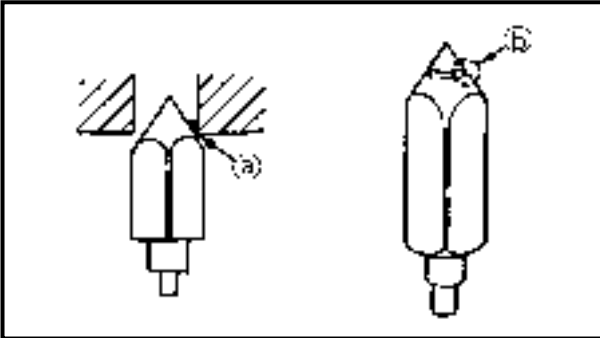

Needle valve inspection

1. Inspect:

- Needle valve
- Needle valve seat
Contaminants ① → Clean.
Wear ② → Replace.

NOTE:

Always replace the needle valve and needle valve seat as a set.

Jet and carburetor body inspection

1. Inspect:

- Main jet
- Pilot jet
- Carburetor body
Clog/contaminants → Clean.
Damage/wear → Replace.

CAUTION:

Do not use a steel wire to clean the jets. This may enlarge the jet diameters and seriously affect performance.

Carburetor assembly

NOTE:

Before assembling the carburetor, make sure to turn out the pilot screw the same number of times, as noted before disassembly, from the seated position to the set position.

1. Adjust:

- Trolling speed
Refer to "FUEL SYSTEM" in chapter 3.

**FUEL PUMP
EXPLODED DIAGRAM**

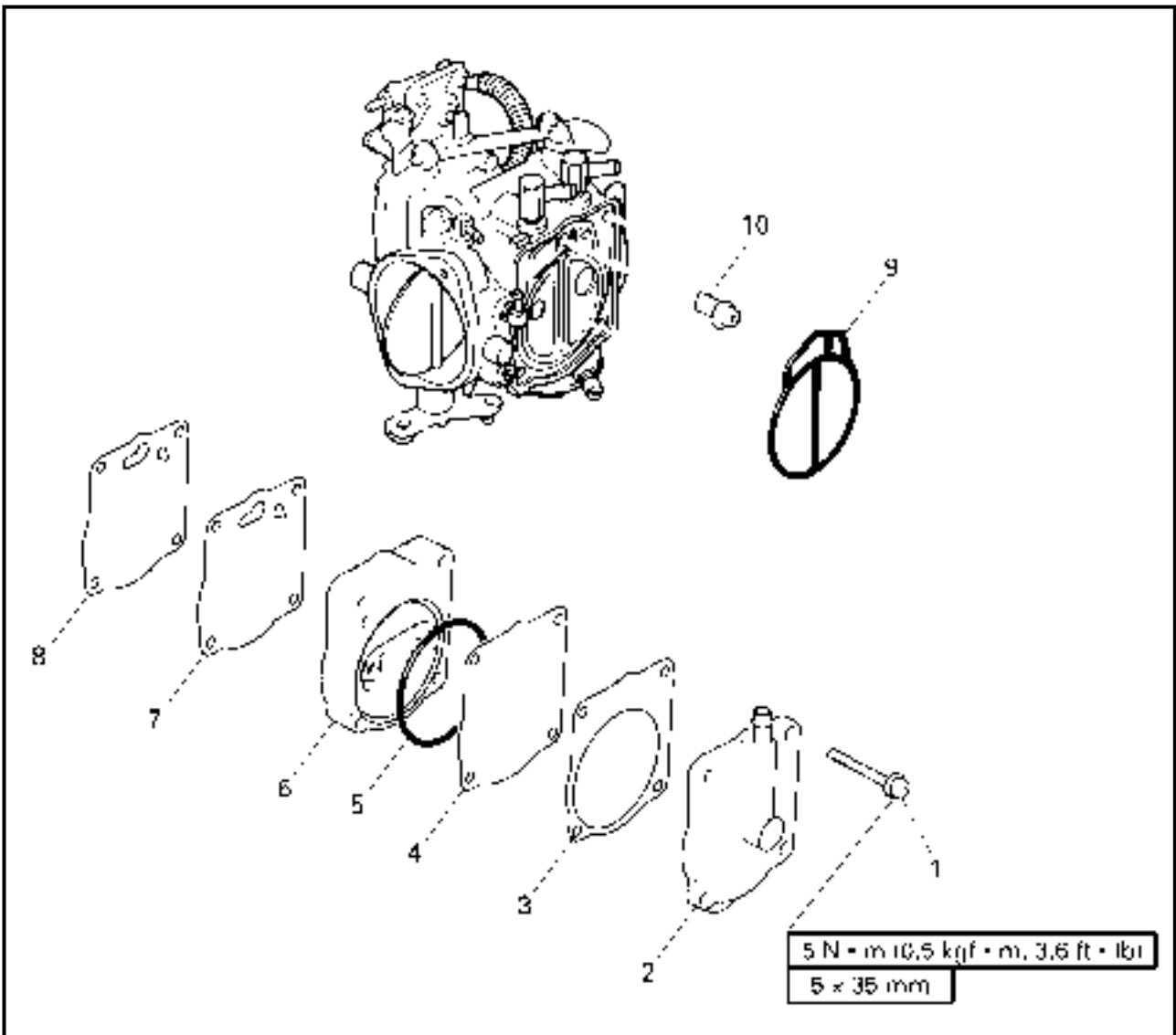

REMOVAL AND INSTALLATION CHART

Step	Procedure/Part name	Q'ty	Service points
	FUEL PUMP DISASSEMBLY		
	Carburetors		Follow the left "Step" for disassembly. Refer to "CARBURETOR UNIT".
1	Screw	4	
2	Fuel pump cover	1	
3	Gasket	1	Not reusable
4	Diaphragm	1	
5	O-ring	1	
6	Diaphragm body	1	



EXPLODED DIAGRAM

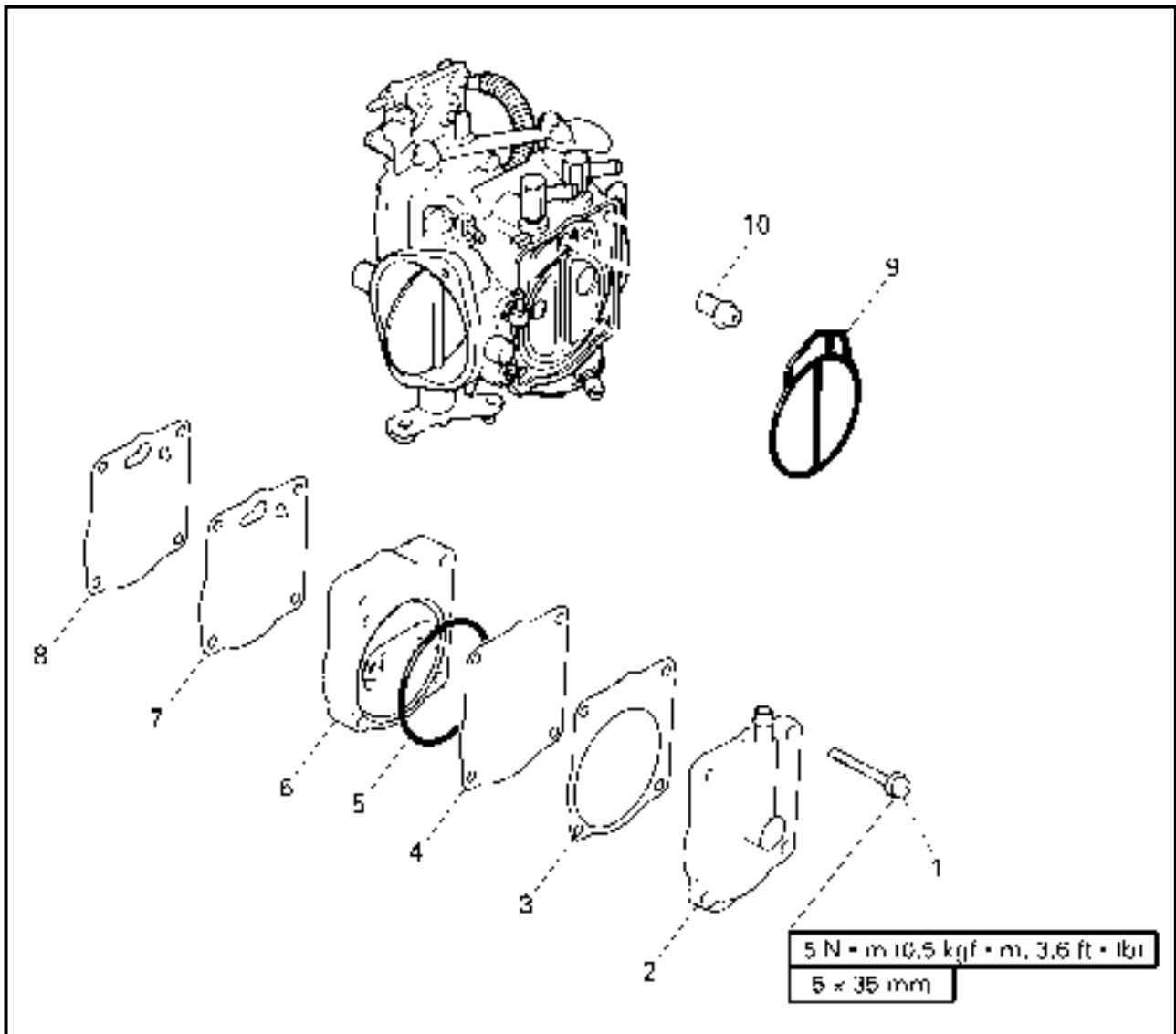

Step	Procedure/Part name	Q'ty	Service points
7	Rubber diaphragm	1	Reverse the disassembly steps for assembly.
8	Diaphragm	1	
9	Packing	1	
10	Fuel filter	1	



SERVICE POINTS

Fuel pump inspection

1. Inspect:

- Diaphragm
 - Rubber diaphragm
 - Diaphragm body
- Damage → Replace.

Fuel filter inspection

1. Inspect:

- Fuel filter
- Clog/contaminants → Clean.
Damage → Replace.

**OIL PUMP
EXPLODED DIAGRAM**

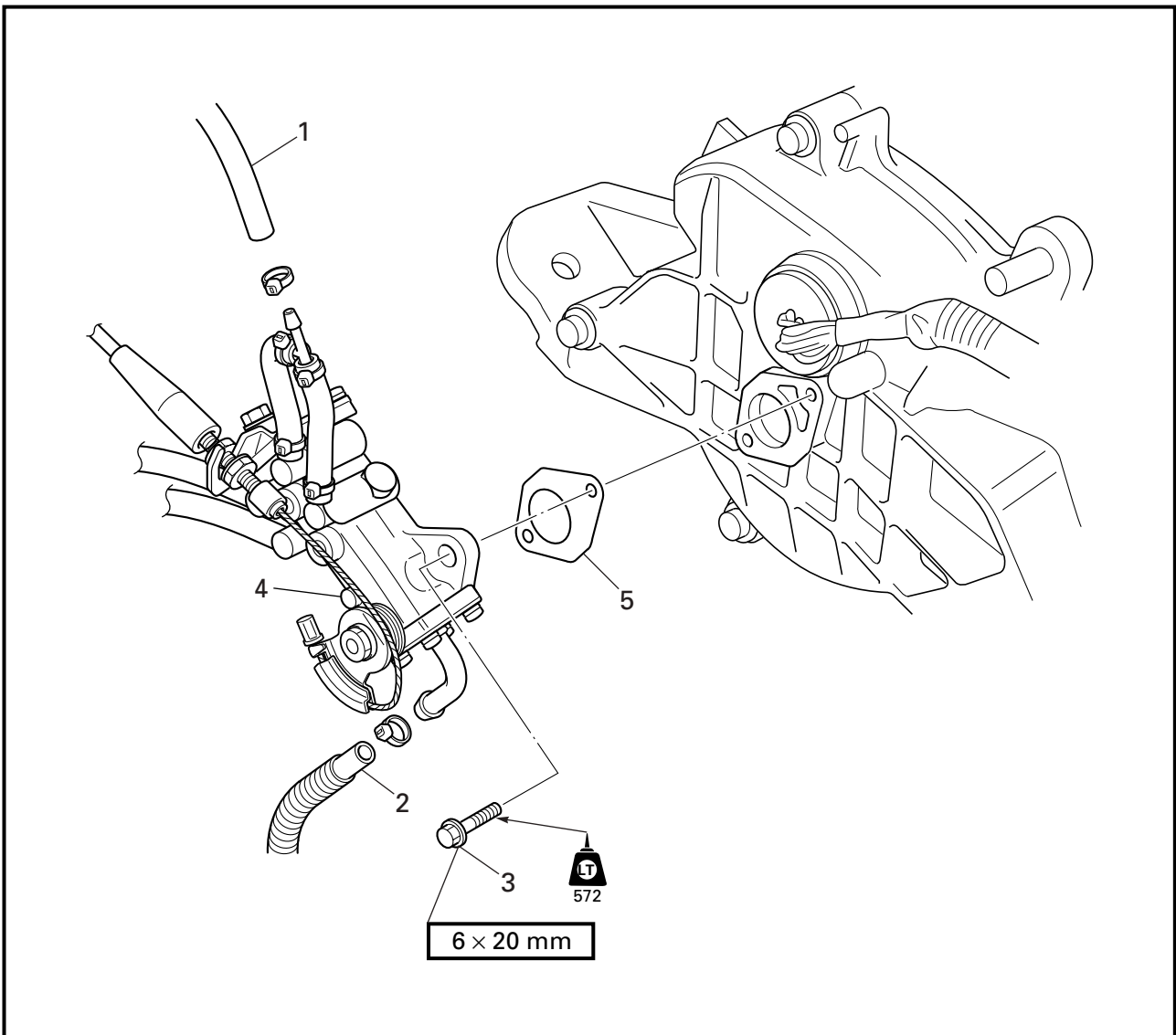

REMOVAL AND INSTALLATION CHART

Step	Procedure/Part name	Q'ty	Service points
	OIL PUMP REMOVAL		Follow the left "Step" for removal. Refer to "CARBURETOR UNIT". Refer to "CARBURETOR UNIT".
	Exhaust chamber assembly		
	Oil pump cable and oil feed hoses		
1	Oil return hose	1	NOTE: _____
2	Oil hose	1	When removing the oil pump, the exhaust chamber assembly does not need to be removed if the engine unit has already been removed.
3	Bolt	2	
4	Oil pump assembly	1	
5	Gasket	1	Not reusable Reverse the removal steps for installation.



EXPLODED DIAGRAM

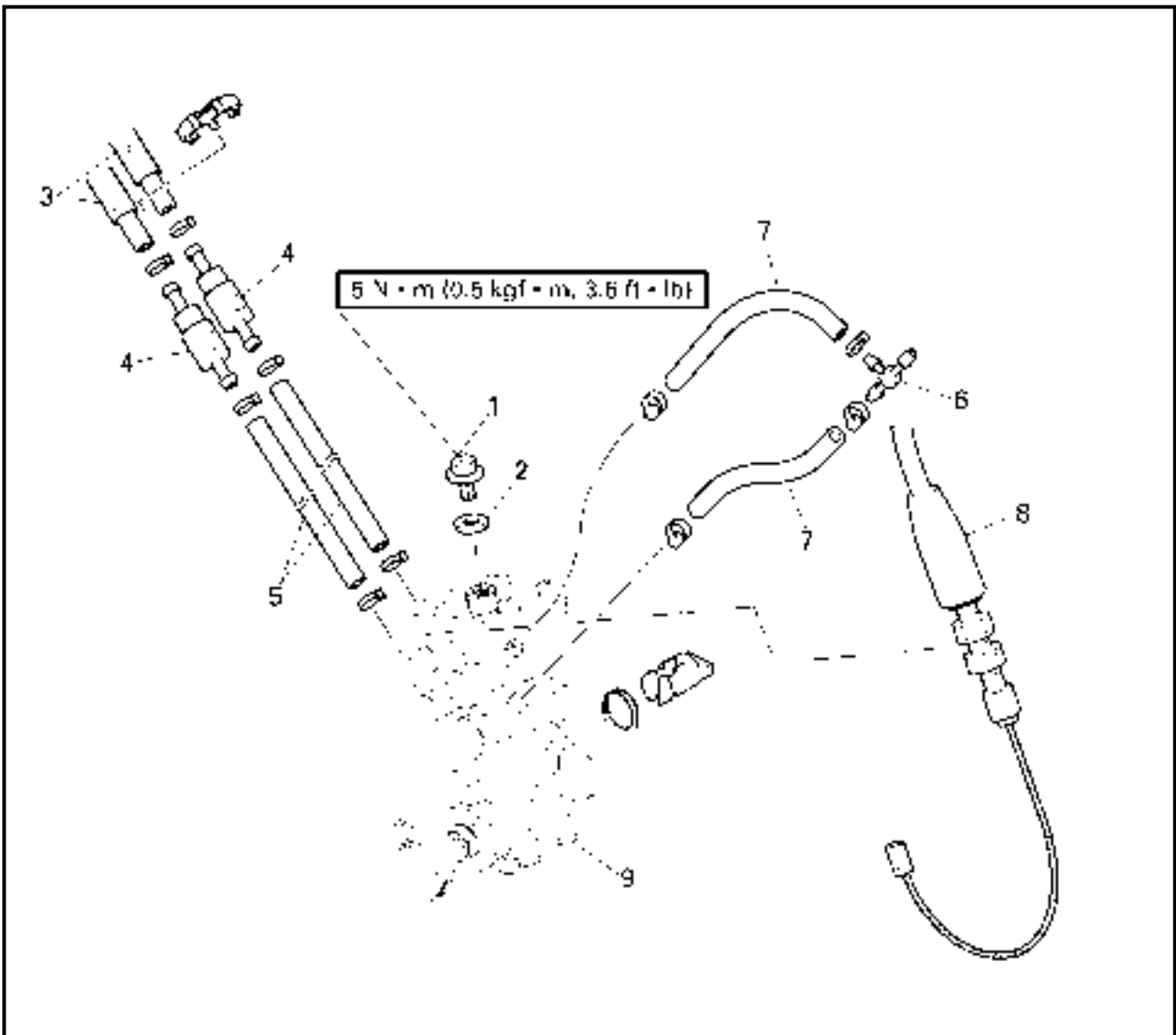

REMOVAL AND INSTALLATION CHART

Step	Procedure/Part name	Q'ty	Service points
	OIL PUMP HOSES AND CABLE REMOVAL		Follow the left "Step" for removal.
1	Air bleed screw	1	
2	Gasket	1	
3	Oil feed hose 1	2	
4	Check valve	2	
5	Oil feed hose 2	2	
6	Hose joint	1	
7	Oil return hose	2	
8	Oil pump cable	1	
9	Oil pump	1	
			Reverse the removal steps for installation.



SERVICE POINTS

Oil pump inspection

1. Inspect:

- Oil pump
Contaminants → Clean.
Damage/wear → Replace.
- Oil pump joint piece
Damage/wear → Replace.

Oil hose inspection

1. Inspect:

- Oil hose
Cracks/damage → Replace.

CAUTION:

If the oil feed hoses are not full of oil, fill them up.

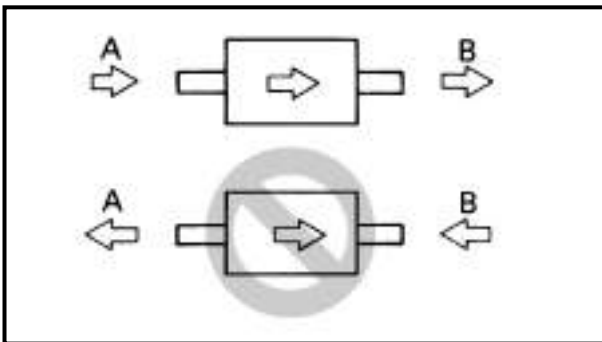

Check valve inspection

1. Check:

- Check valve
Faulty → Replace.

Checking steps:

- Connect a hose to the end of check valve "A" and blow into it.
Air should come out from end "B".
- Connect the hose to the end of check valve "B" and blow into it.
Air should not come out from end "A".

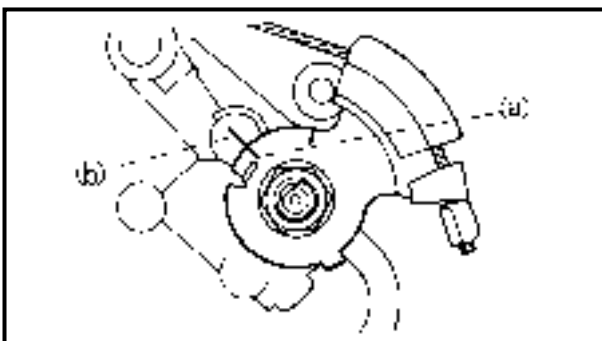

Oil pump cable adjustment

1. Check:

- Oil pump lever position
Incorrect → Adjust.

Checking steps:

- Fully close the carburetor throttle valves.
- Check that the mark ① on the oil pump lever is aligned with the mark ② on the oil pump body.

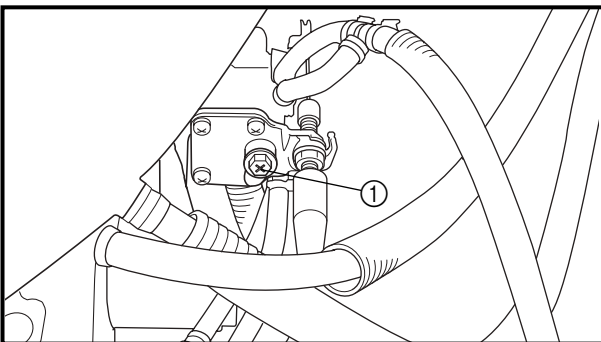
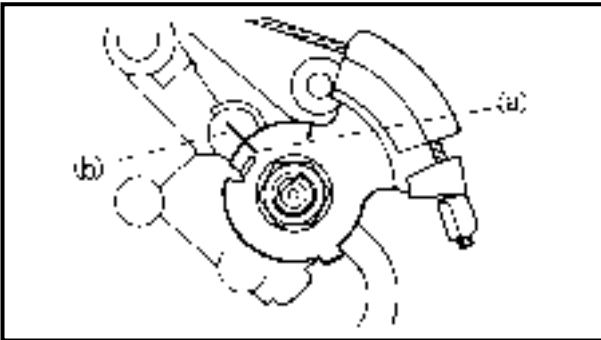
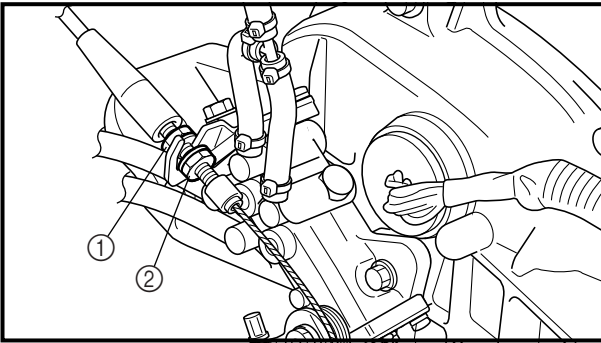

2. Adjust:

- Oil pump cable

Adjustment steps:

- Loosen the locknut ① and the adjusting nut ②.
- Fully close the carburetor throttle valves.
- Adjust the oil pump cable so that the mark (a) on the oil pump lever is aligned with the mark (b) on the oil pump body.
- Tighten the adjusting nut and locknut.

Oil injection pump air bleeding

1. Bleed:

- Air

Air bleeding steps:

- Place rags around the air bleed screw ① to catch any oil that might spill.
- Fill the oil tank with the recommended oil.

NOTE:

If the oil pump is replaced or the oil suction hose is removed, bleed air from the oil suction hose by removing it from the oil pump.

After bleeding the air, reconnect the hose with a locking tie.



Recommended engine oil:
YAMALUBE 2-W or an
equivalent TC-W3 certified
outboard oil

- Loosen the air bleed screw ① two full turns and make sure that both the oil and air bubbles flow out.
- When there are no air bubbles left, tighten the air bleed screw.
- Wipe up any spilt oil.



OIL PUMP

E



Air bleed screw:
5 N · m (0.5 kgf · m, 3.6 ft · lb)

CAUTION: _____

Do not run the engine if oil does not flow out of the air bleed screw. Inspect the oil pump hoses for proper routing and make sure there are no restrictions in the line.



CHAPTER 5 POWER UNIT

ENGINE UNIT	5-1
EXPLODED DIAGRAM	5-1
REMOVAL AND INSTALLATION CHART	5-1
SERVICE POINTS	5-5
Shim removal	5-5
Engine mount inspection	5-5
Coupling clearance inspection	5-5
EXHAUST CHAMBER ASSEMBLY	5-6
EXPLODED DIAGRAM	5-6
REMOVAL AND INSTALLATION CHART	5-6
EXHAUST CHAMBER JOINT	5-10
EXPLODED DIAGRAM	5-10
REMOVAL AND INSTALLATION CHART	5-10
EXHAUST MANIFOLD	5-12
EXPLODED DIAGRAM	5-12
REMOVAL AND INSTALLATION CHART	5-12
REED VALVES	5-13
EXPLODED DIAGRAM	5-13
REMOVAL AND INSTALLATION CHART	5-13
SERVICE POINTS	5-14
Reed valve inspection	5-14
YPVS	5-15
EXPLODED DIAGRAM	5-15
REMOVAL AND INSTALLATION CHART	5-15
SERVICE POINTS	5-17
YPVS valve inspection	5-17
YPVS valve installation	5-17
CYLINDER HEAD	5-18
EXPLODED DIAGRAM	5-18
REMOVAL AND INSTALLATION CHART	5-18
SERVICE POINTS	5-19
Cylinder head inspection	5-19



CYLINDERS 5-20

 EXPLODED DIAGRAM 5-20

 REMOVAL AND INSTALLATION CHART 5-20

 SERVICE POINTS 5-21

 Cylinder inspection 5-21

PISTONS 5-22

 EXPLODED DIAGRAM 5-22

 REMOVAL AND INSTALLATION CHART 5-22

 SERVICE POINTS 5-24

 Piston pin clip removal and installation 5-24

 Piston inspection 5-24

 Cylinder and piston combination 5-25

 Piston ring inspection 5-25

 Piston pin and bearing inspection 5-26

STARTER MOTOR 5-28

 EXPLODED DIAGRAM 5-28

 REMOVAL AND INSTALLATION CHART 5-28

FLYWHEEL MAGNETO 5-29

 EXPLODED DIAGRAM 5-29

 REMOVAL AND INSTALLATION CHART 5-29

 SERVICE POINTS 5-34

 Drive coupling removal and installation 5-34

 Flywheel magneto removal and installation 5-34

 Drive coupling inspection 5-35

 Flywheel magneto inspection 5-35

 Starter clutch assembly inspection 5-35

CRANKCASE 5-36

 EXPLODED DIAGRAM 5-36

 REMOVAL AND INSTALLATION CHART 5-36

 SERVICE POINTS 5-38

 Crankcase inspection 5-38

 Crankcase installation 5-38

CRANKSHAFT 5-39

 EXPLODED DIAGRAM 5-39

 REMOVAL AND INSTALLATION CHART 5-39

 SERVICE POINTS 5-40

 Crankshaft inspection 5-40



**ENGINE UNIT
EXPLODED DIAGRAM**

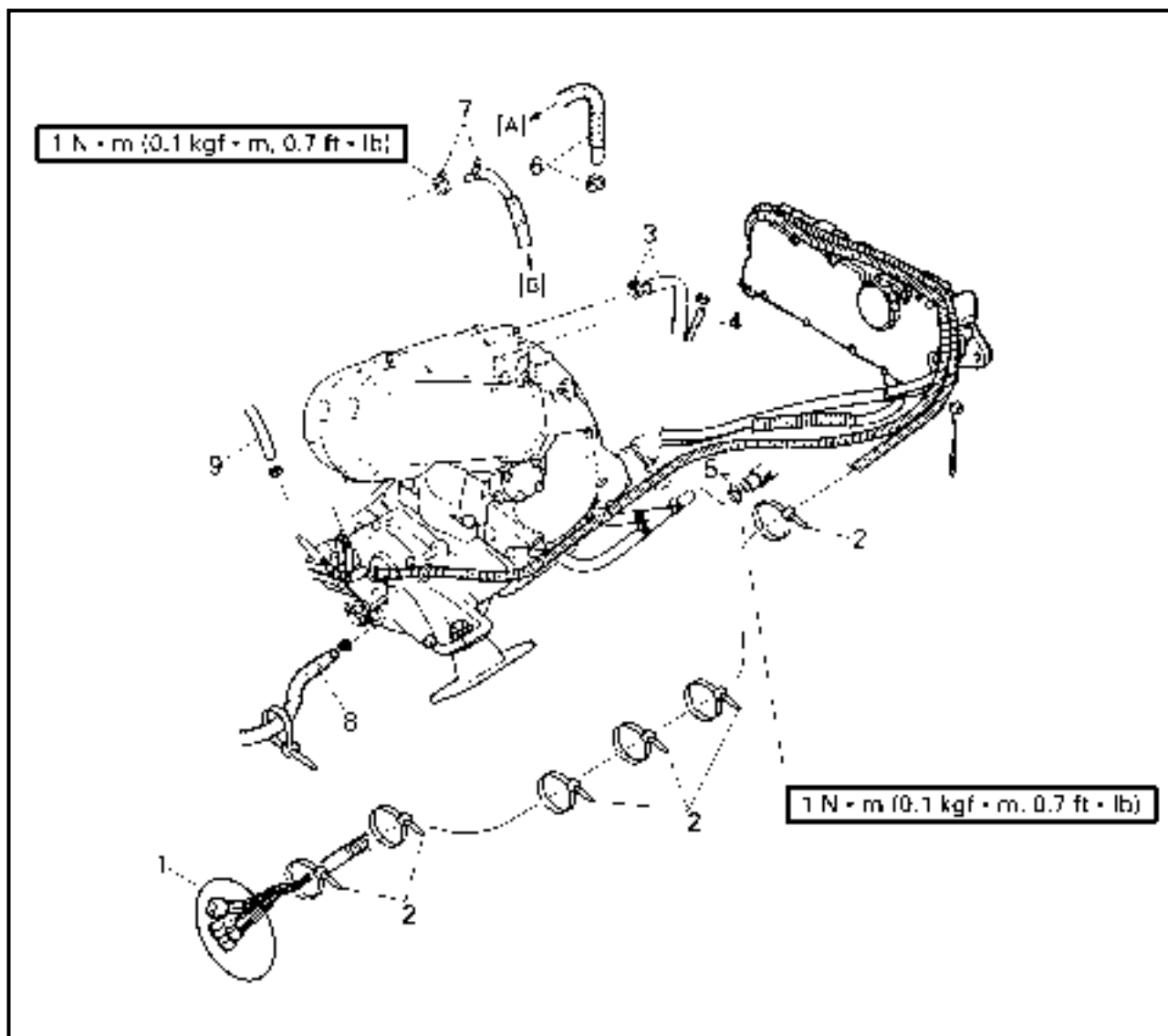

REMOVAL AND INSTALLATION CHART

Step	Procedure/Part name	Q'ty	Service points
	ENGINE UNIT REMOVAL		Follow the left "Step" for removal.
	Battery box		Refer to "BATTERY BOX" in chapter 8.
	YPVS cables and YPVS servomotor		Refer to "YPVS SERVOMOTOR" in chapter 7.
	Intake silencer		Refer to "INTAKE SILENCER" in chapter 4.
	Choke cable, throttle cable and fuel hoses		Refer to "CARBURETOR UNIT" in chapter 4.
1	Coupler	3	
2	Band	6	
3	Clamp/Cooling water hose	1	



EXPLODED DIAGRAM

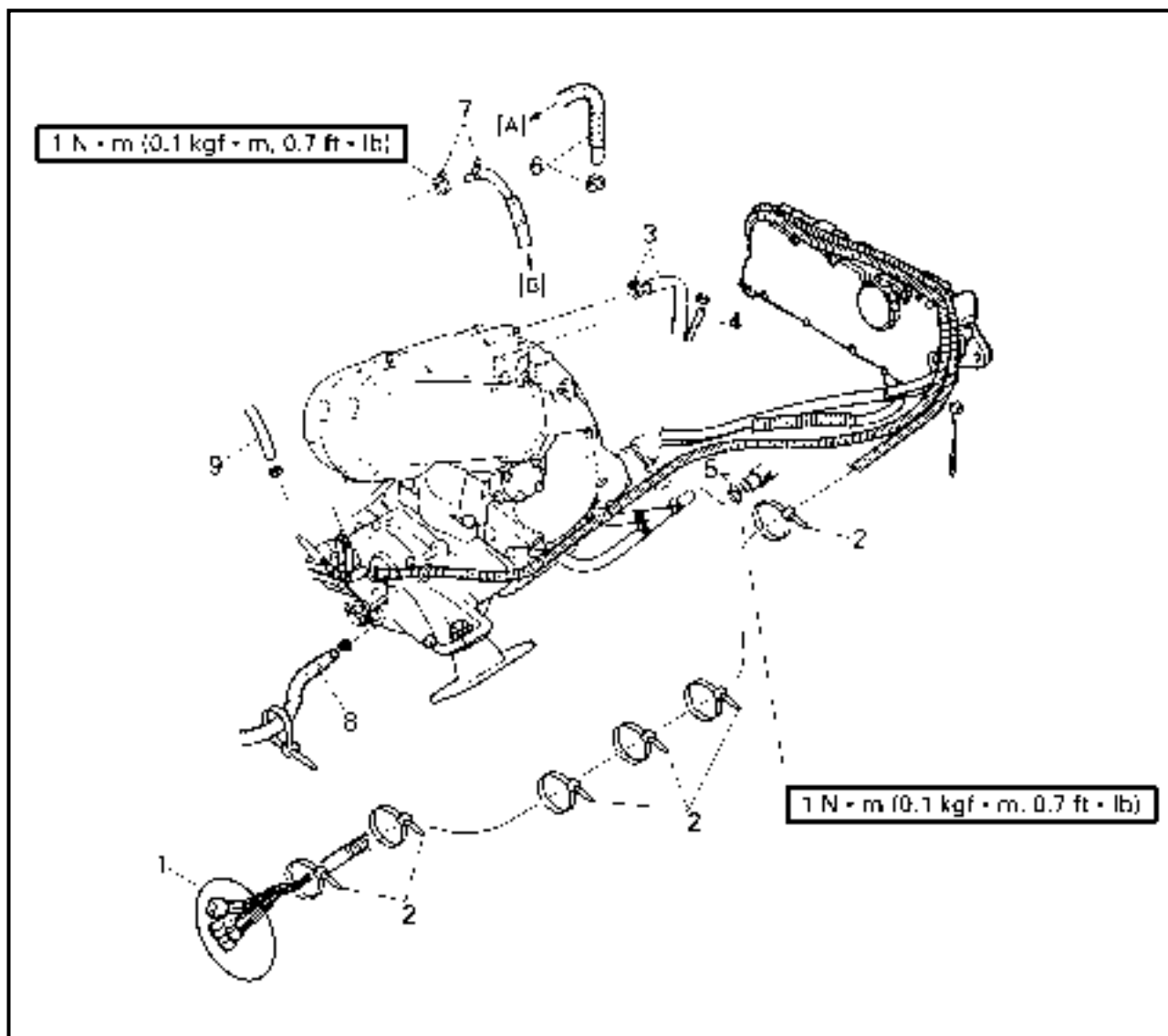

Step	Procedure/Part name	Q'ty	Service points
4	Grease hose	1	
5	Clamp/cooling water hose	1/1	
6	Clamp/cooling water hose	1/1	[A] For cooling water pilot outlet on starboard side
7	Clamp/cooling water hose	1/1	[B] For cooling water pilot outlet on port side
8	Oil hose	1	
9	Oil return hose	1	



EXPLODED DIAGRAM

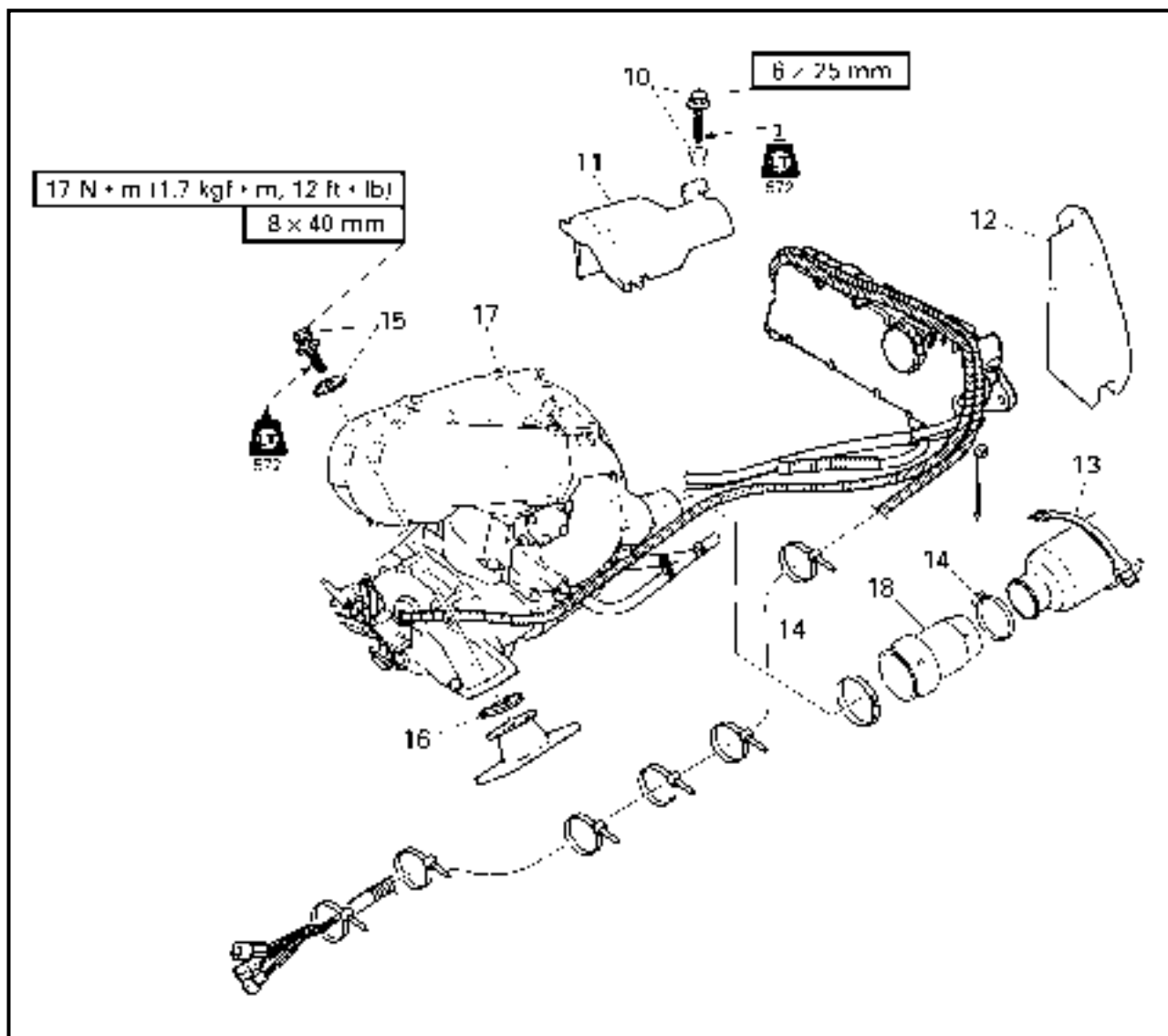

Step	Procedure/Part name	Q'ty	Service points
10	Bolt/collar	1/1	NOTE: _____ ● Before removing the engine unit, fix the choke valves to the choke link with a plastic band, etc. to the fully closed position. ● When lifting the engine unit, hook the hoister on the bow side of muffler stay 1. ● Lift the engine unit carefully trying not hit it on the deck. _____
11	Coupling cover	1	
12	Floatation	1	
13	Water lock band	1	
14	Hose clamp	2	
15	Bolt/washer	4/4	



SERVICE POINTS

Shim removal

1. Remove:
 - Shims

NOTE: _____

To ease reassembly and coupling alignment, remove the shims and organize them in their respective groups (e.g., front right, rear left) prior to removing the mounting bolts.

Engine mount inspection

1. Inspect:
 - Engine mounts
Cracks/damage → Replace.

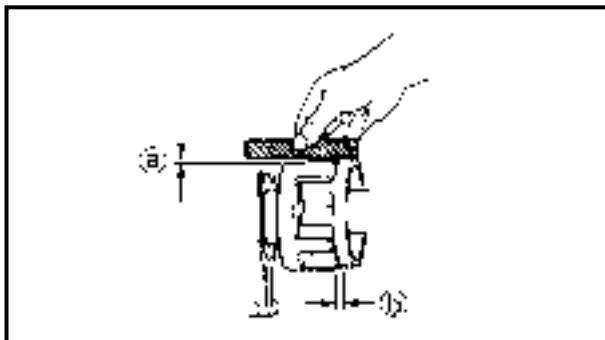

Coupling clearance inspection

1. Measure:
 - Clearance Ⓐ
 - Clearance Ⓑ
 (with the rubber damper)
 Out of specification → Adjust.

NOTE: _____

Measure the clearances with a straightedge and thickness gauge.



Clearance Ⓐ:
 0–0.5 mm (0–0.020 in)
Clearance Ⓑ:
 2–4 mm (0.079–0.157 in)

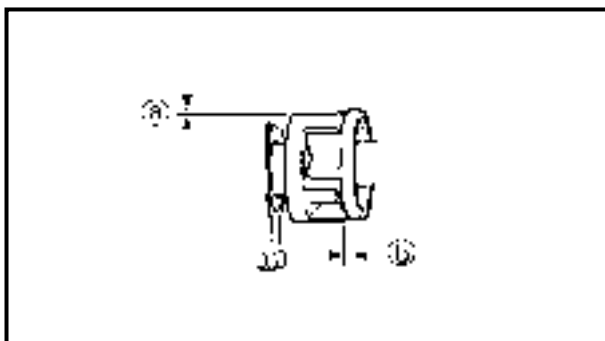

2. Adjust:
 - Clearance Ⓐ and Ⓑ

Adjustment steps:

- Adjust the clearance Ⓐ by adding or removing shims.
- Adjust the clearance Ⓑ by moving the engine unit position.



**EXHAUST CHAMBER ASSEMBLY
EXPLODED DIAGRAM**

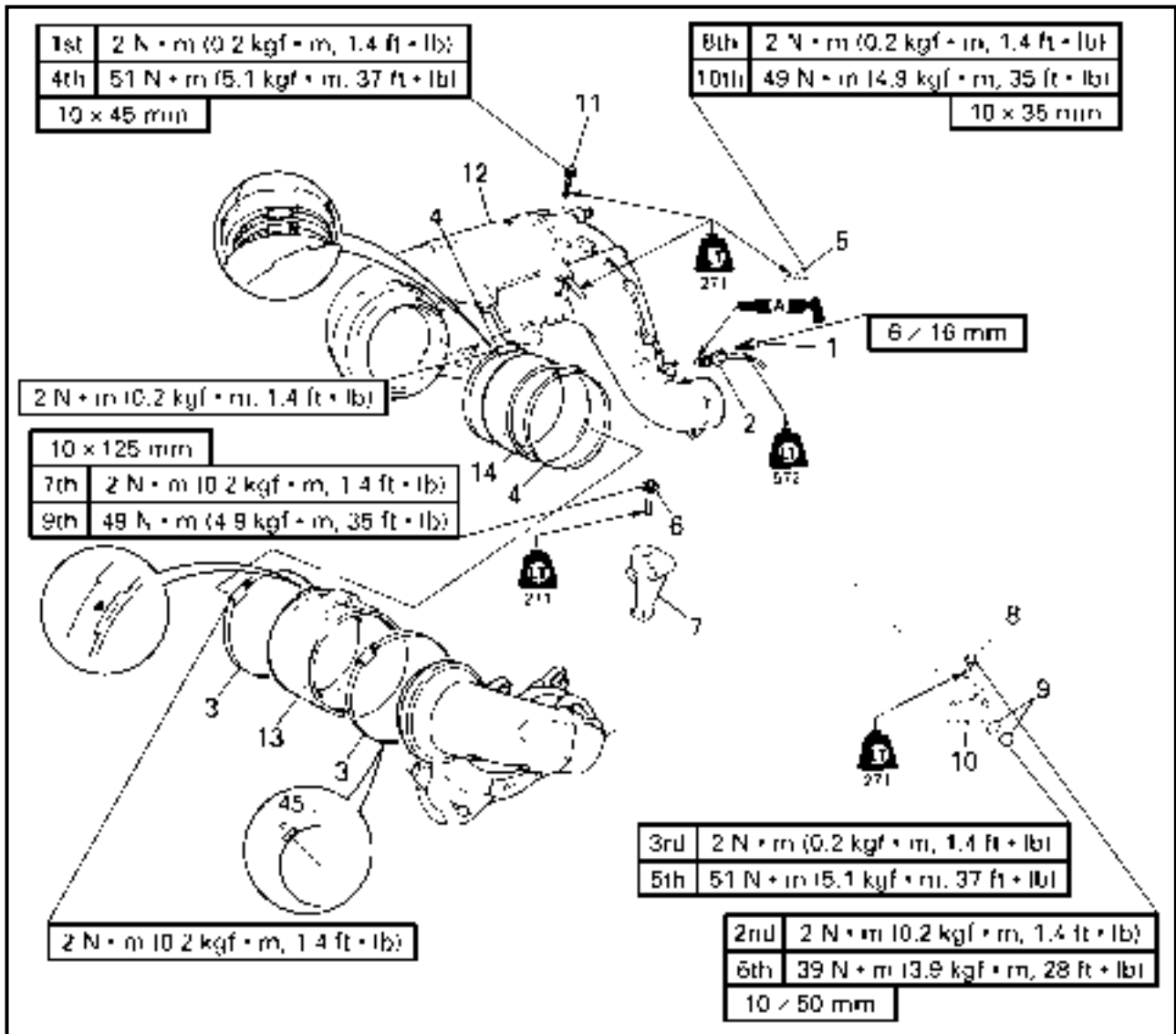

REMOVAL AND INSTALLATION CHART

Step	Procedure/Part name	Q'ty	Service points
	EXHAUST CHAMBER ASSEMBLY REMOVAL		Follow the left "Step" for removal.
	Engine unit		Refer to "ENGINE UNIT".
1	Bolt	2	
2	Thermoswitch	1	
3	Hose clamp	2	Slide the outer exhaust joint.
4	Hose clamp	2	
5	Bolt	1	
6	Bolt	1	
7	Muffler stay 3	1	
8	Bolt	4	



EXPLODED DIAGRAM

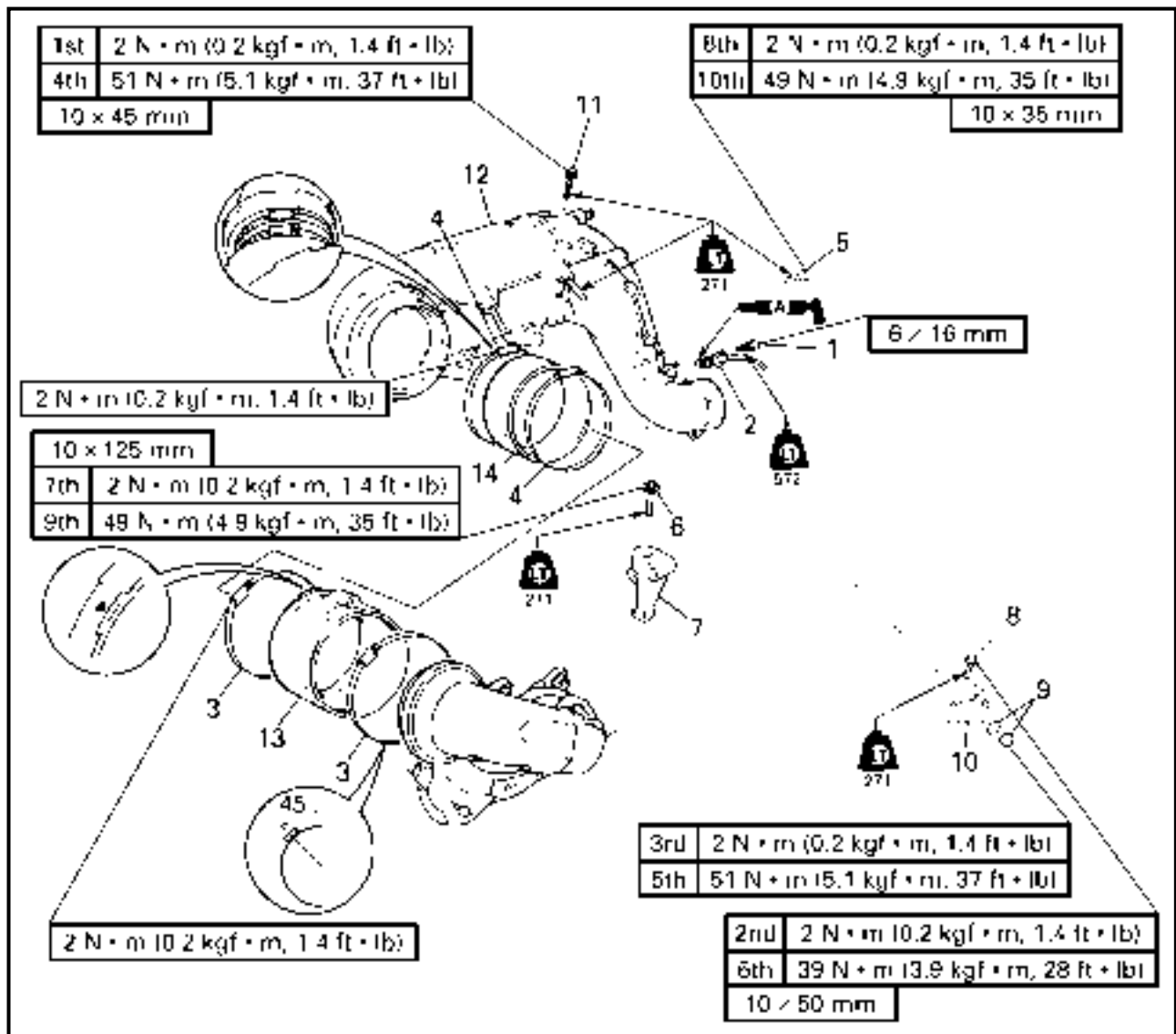

Step	Procedure/Part name	Q'ty	Service points
9	Nut/washer	2/2	<p>NOTE: _____ Make sure to remove spark plugs before removing the muffler stay 1. _____ Reverse the removal steps for installation.</p>
10	Muffler stay 1	2	
11	Bolt	2	
12	Exhaust chamber assembly	1	
13	Outer exhaust joint	1	
14	Inner exhaust joint	1	



EXPLODED DIAGRAM

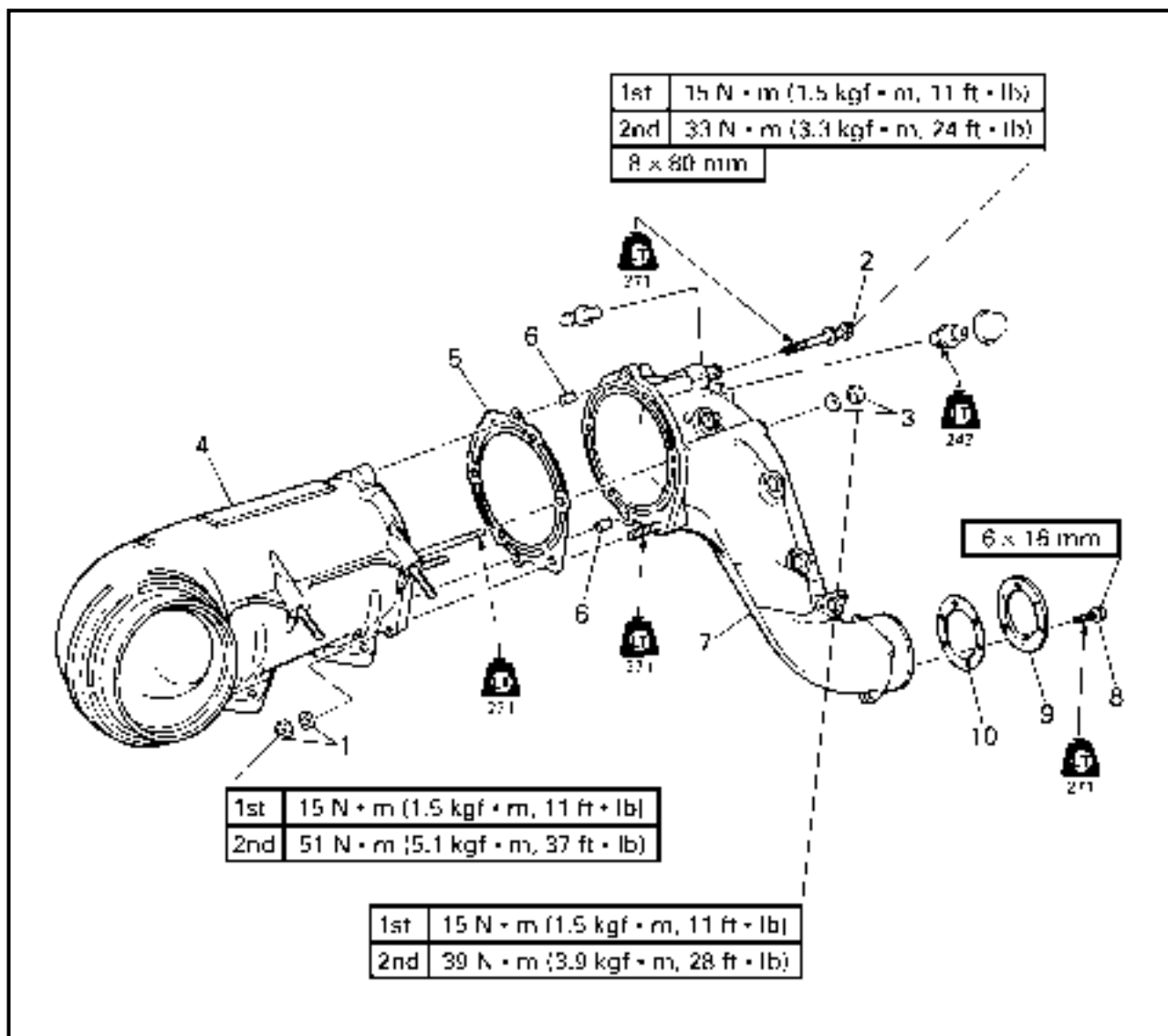

REMOVAL AND INSTALLATION CHART

Step	Procedure/Part name	Q'ty	Service points
	EXHAUST CHAMBER DISASSEMBLY		Follow the left "Step" for disassembly.
1	Nut/washer	1/1	
2	Bolt	3	
3	Nut/washer	2/2	
4	Exhaust chamber	1	
5	Gasket	1	Not reusable
6	Pin	2	



EXPLODED DIAGRAM

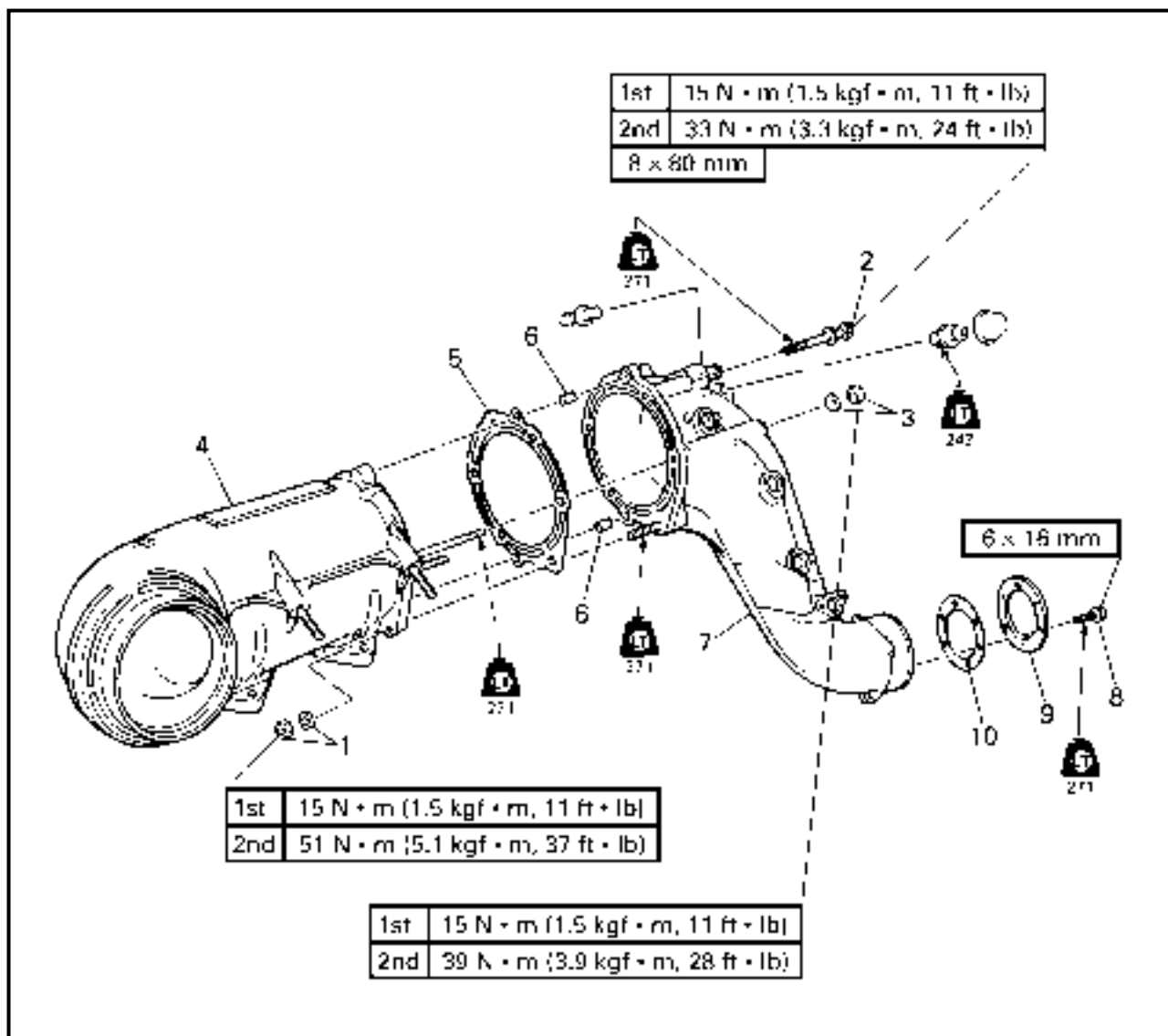

Step	Procedure/Part name	Q'ty	Service points
7	Muffler	1	<p>Not reusable Reverse the disassembly steps for assembly.</p>
8	Screw	3	
9	Plate	1	
10	Gasket	1	



**EXHAUST CHAMBER JOINT
EXPLODED DIAGRAM**

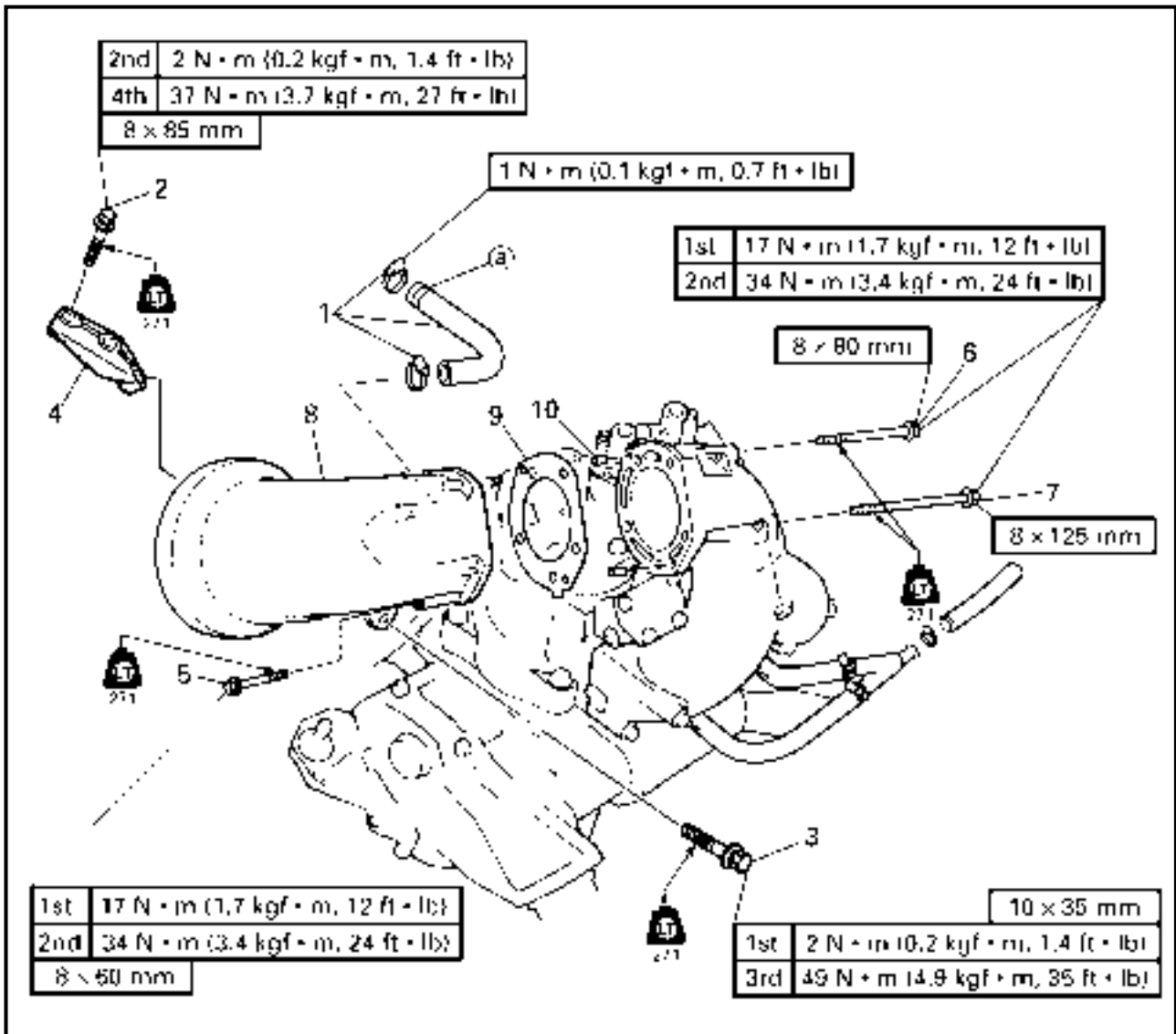

REMOVAL AND INSTALLATION CHART

Step	Procedure/Part name	Q'ty	Service points
	EXHAUST CHAMBER JOINT REMOVAL		Follow the left "Step" for removal.
	Exhaust chamber assembly		Refer to "EXHAUST CHAMBER ASSEMBLY".
1	Clamp/cooling water hose	2/1	Ⓐ white mark
2	Bolt	2	
3	Bolt	1	
4	Muffler stay	1	
5	Bolt	1	



EXPLODED DIAGRAM

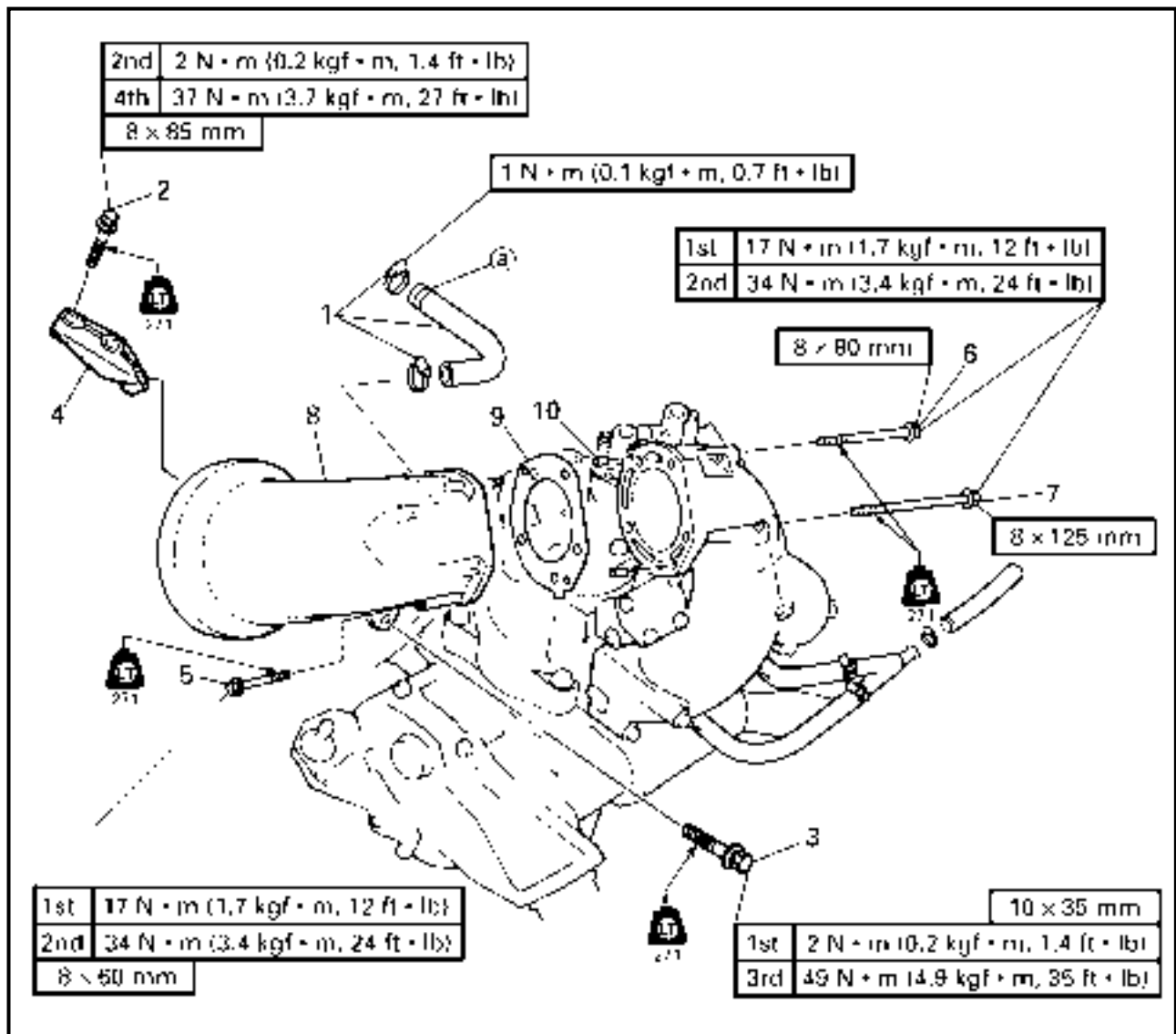

Step	Procedure/Part name	Q'ty	Service points
6	Bolt	2	<p>Not reusable</p> <p>Reverse the removal steps for installation.</p>
7	Bolt	2	
8	Exhaust chamber joint	1	
9	Gasket	1	
10	Pin	2	



**EXHAUST MANIFOLD
EXPLODED DIAGRAM**

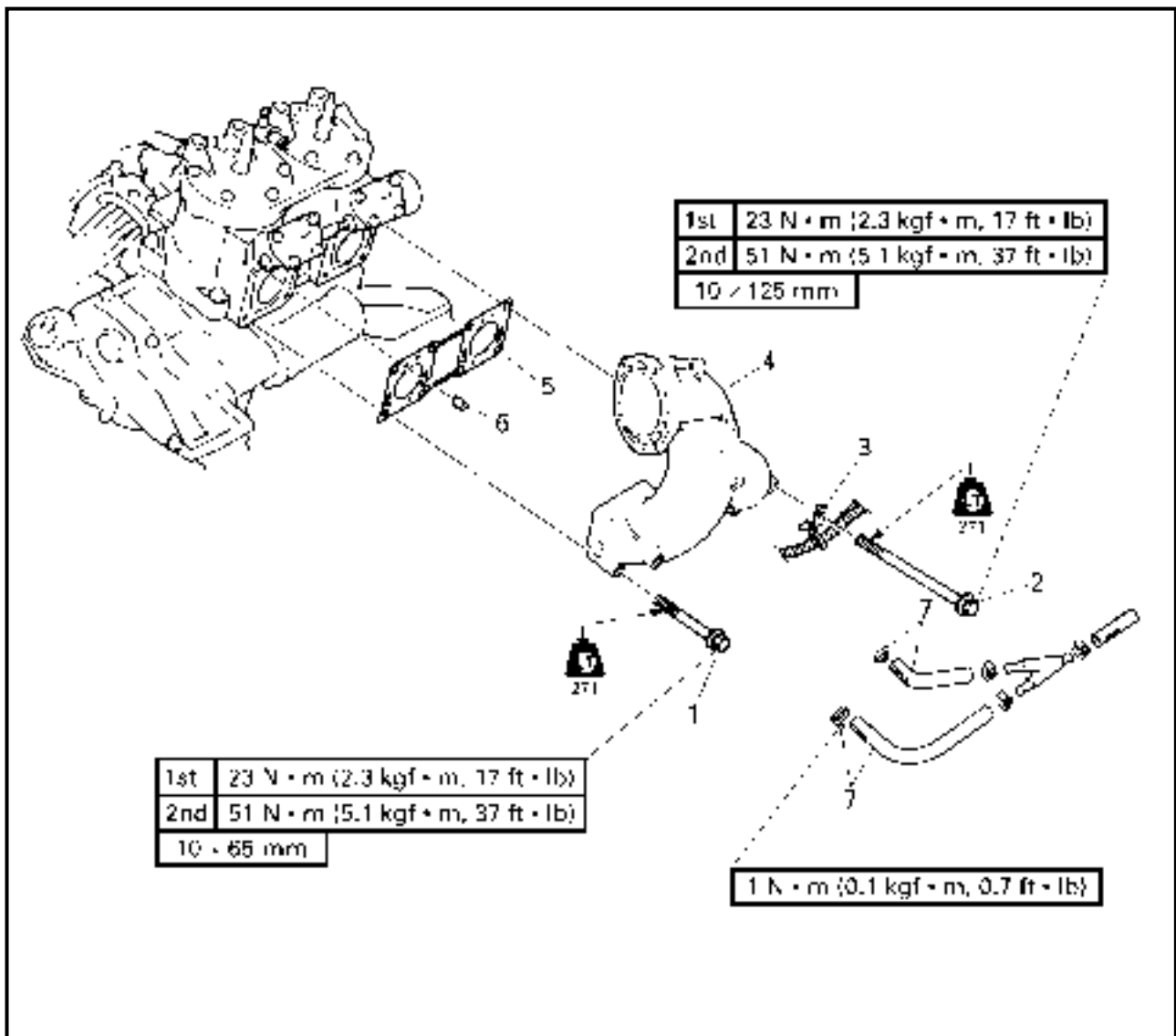

REMOVAL AND INSTALLATION CHART

Step	Procedure/Part name	Q'ty	Service points
	EXHAUST MANIFOLD REMOVAL		Follow the left "Step" for removal. Refer to "EXHAUST CHAMBER JOINT".
	Exhaust chamber joint		
1	Bolt	4	
2	Bolt	4	
3	Wire harness bracket	2	
4	Exhaust manifold	1	
5	Gasket	1	Not reusable
6	Pin	2	
7	Clamp/cooling water hose	2/2	
			Reverse the removal steps for installation.



**REED VALVES
EXPLODED DIAGRAM**

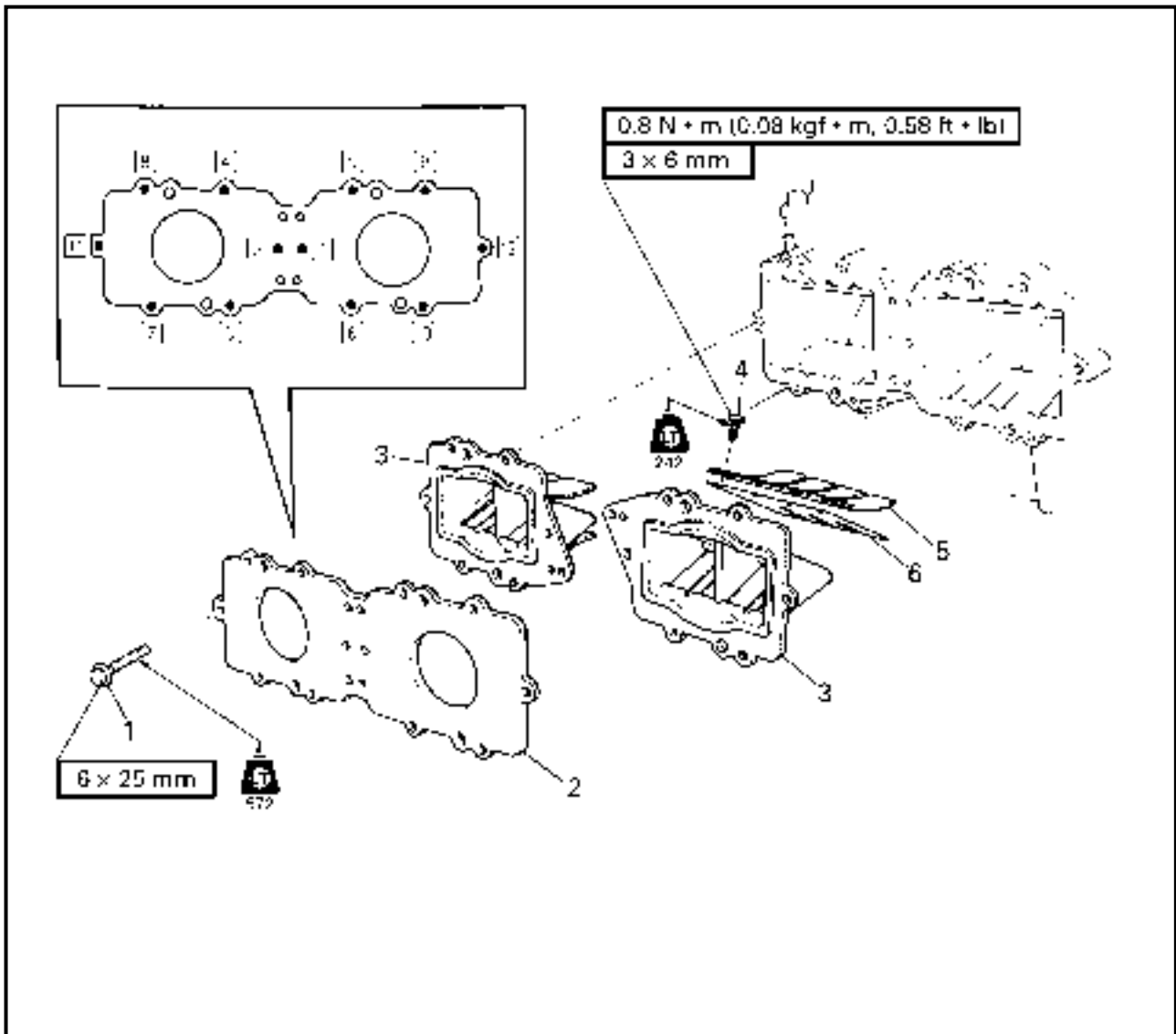

REMOVAL AND INSTALLATION CHART

Step	Procedure/Part name	Q'ty	Service points
	REED VALVE REMOVAL Carburetor unit		Follow the left "Step" for removal. Refer to "CARBURETOR UNIT" in chapter 4.
1	Bolt	12	NOTE: _____ Tighten the bolts in the proper sequence as shown. _____ Reverse the removal steps for installation.
2	Reed valve plate	1	
3	Reed valve assembly	2	
4	Screw	16	
5	Valve stopper	4	
6	Reed valve	4	

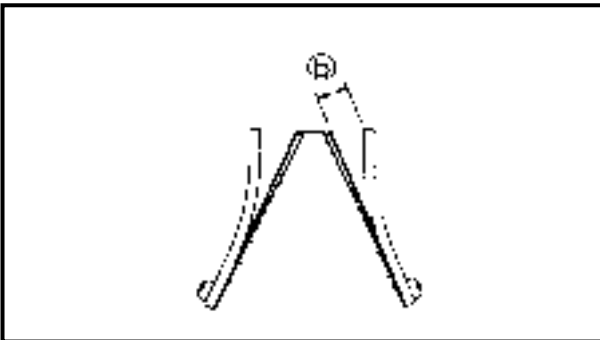
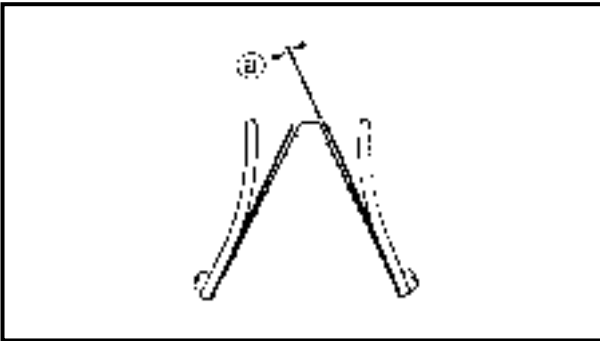

SERVICE POINTS

Reed valve inspection

1. Inspect:
 - Reed valves
Cracks/damage → Replace.
2. Measure:
 - Valve bending **a**
Out of specification → Replace.



Max. valve bending:
0.2 mm (0.01 in)

3. Measure:
 - Valve stopper height **b**
Out of specification → Adjust or replace.



Valve stopper height:
10.8–11.4 mm (0.43–0.45 in)



**YPVS
EXPLODED DIAGRAM**

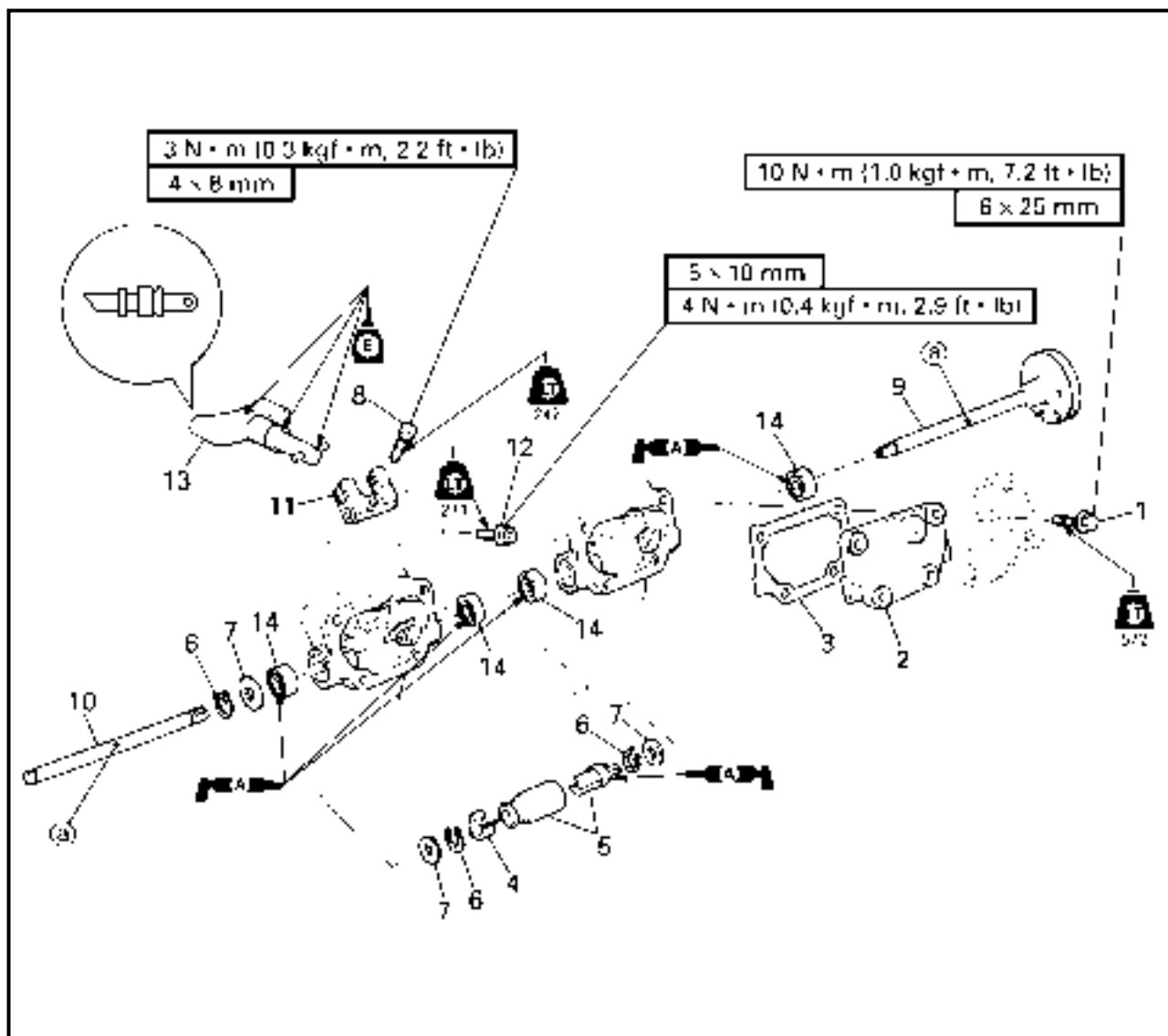

REMOVAL AND INSTALLATION CHART

Step	Procedure/Part name	Q'ty	Service points
	YPVS REMOVAL		Follow the left "Step" for removal. Refer to "EXHAUST MANIFOLD".
	Exhaust manifold		
1	Bolt	8	
2	YPVS valve cover	2	
3	Gasket	2	Not reusable
4	Spacer	1	
5	Link joint/cover	1/1	
6	Circlip	3	Not reusable
7	Washer	3	



EXPLODED DIAGRAM

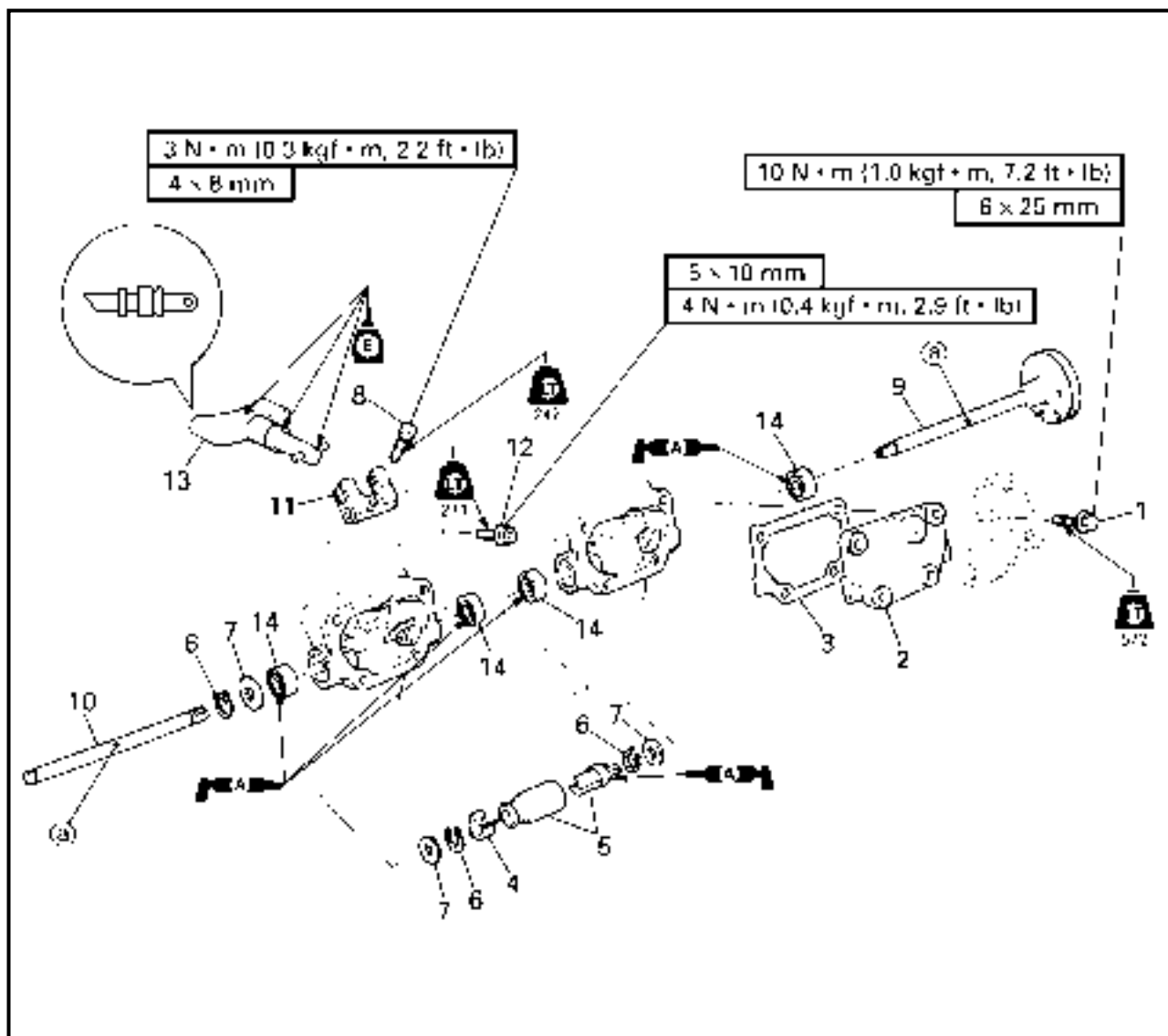

Step	Procedure/Part name	Q'ty	Service points
8	Bolt	2	NOTE: _____ During installation, align the hole Ⓐ in the YPVS shaft with the bolt.
9	Shaft 2	1	
10	Shaft 1	1	
11	YPVS valve lever	2	
12	Bolt	2	NOTE: _____ If the YPVS shaft is removed, the oil seal must be replaced.
13	YPVS valve assembly	2	
14	Oil seal	4	
			Reverse the removal steps for installation.

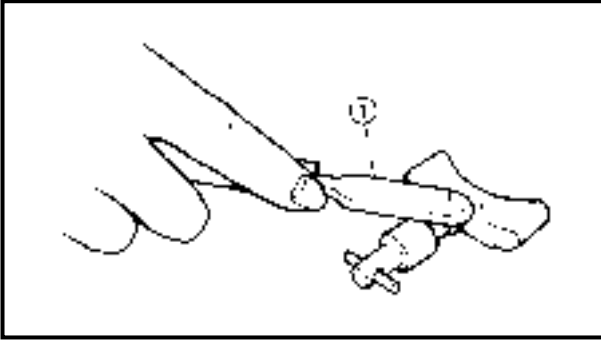

SERVICE POINTS

YPVS valve inspection

1. Eliminate:
 - Carbon deposits
(with a rounded scraper ①)

CAUTION:

Do not use a sharp instrument to avoid damaging or scratching the surfaces.

2. Inspect:
 - YPVS valve assembly
Crack/damage/wear → Replace.

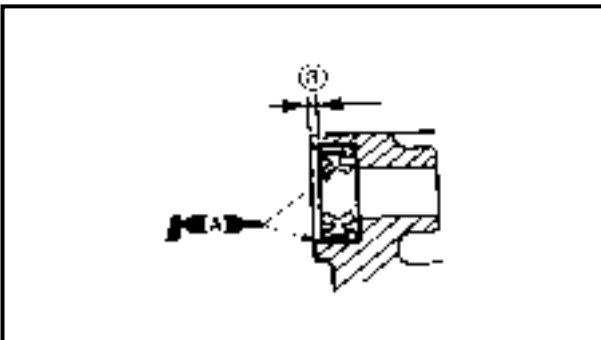

YPVS valve installation

1. Install:
 - Oil seal



Distance ①:
1.0–1.5 mm (0.04–0.06 in)



**CYLINDER HEAD
EXPLODED DIAGRAM**

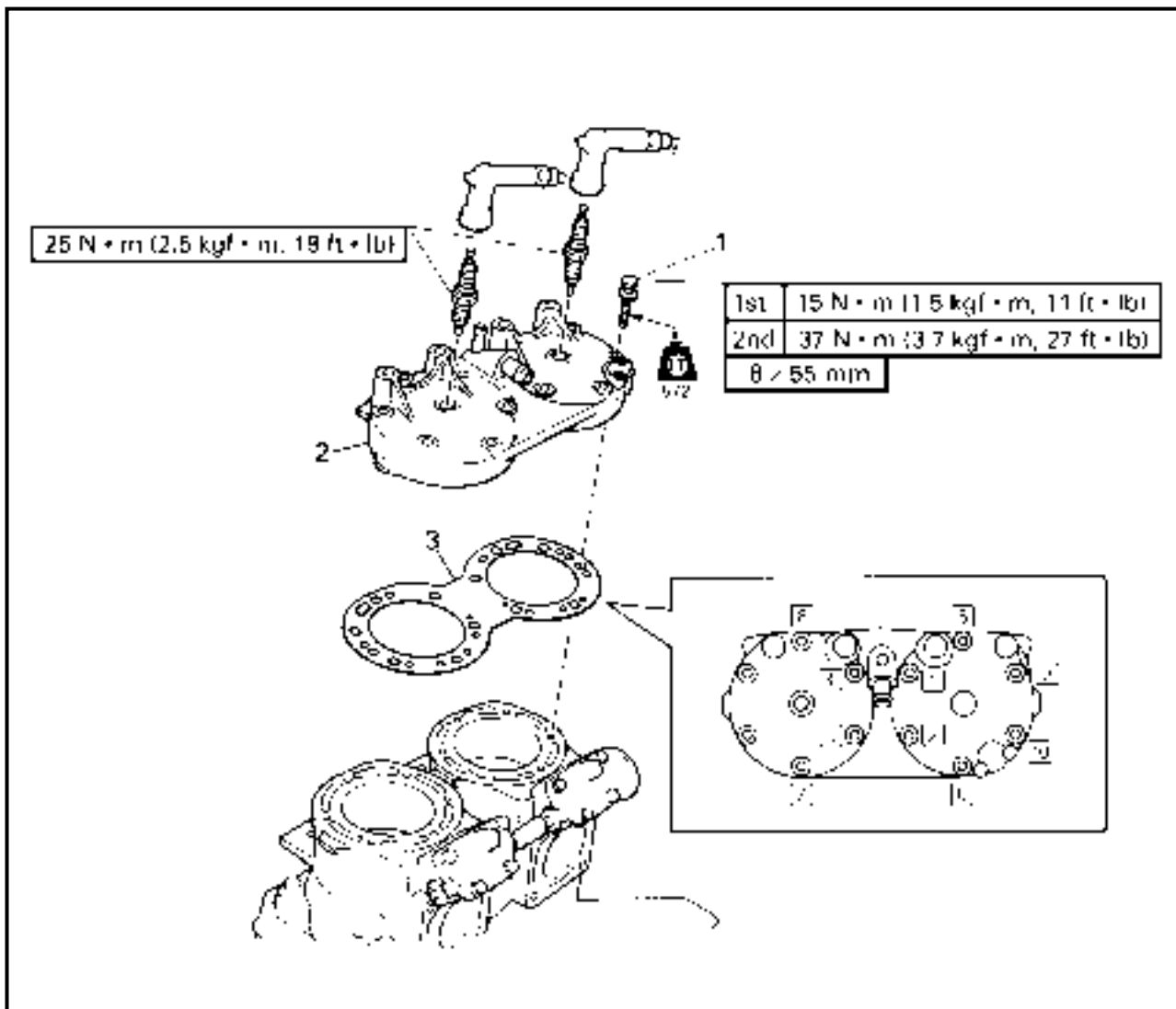

REMOVAL AND INSTALLATION CHART

Step	Procedure/Part name	Q'ty	Service points
CYLINDER HEAD REMOVAL			
1	Exhaust manifold	10	Follow the left "Step" for removal. Refer to "EXHAUST MANIFOLD". NOTE: _____ Tighten the bolts in the proper sequence as shown and in two stages.
	Bolt		
2	Cylinder head	1	Not reusable Reverse the removal steps for installation.
3	Gasket	1	

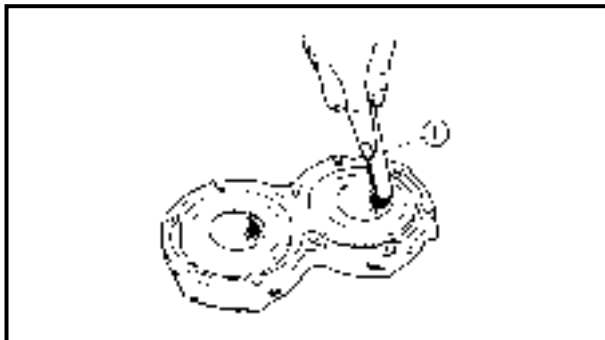

SERVICE POINTS

Cylinder head inspection

1. Eliminate:
 - Carbon deposits
(with a rounded scraper ①)

CAUTION:

Do not use a sharp instrument to avoid damaging or scratching the cylinder head or spark plug bore threads.

2. Inspect:
 - Cylinder head water jacket
Corrosion/mineral deposits → Clean or replace.

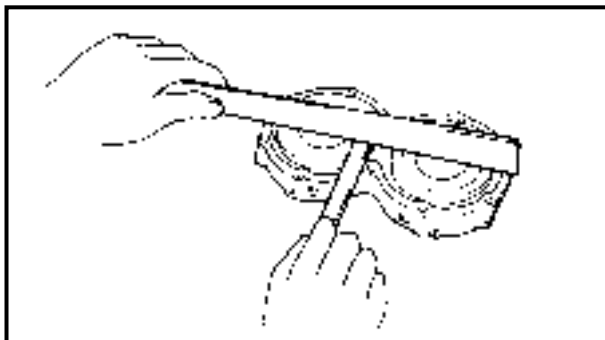

3. Measure:
 - Cylinder head warpage
(with a straightedge and thickness gauge)
Out of specification/score marks → Resurface.



Warpage limit:
0.1 mm (0.004 in)

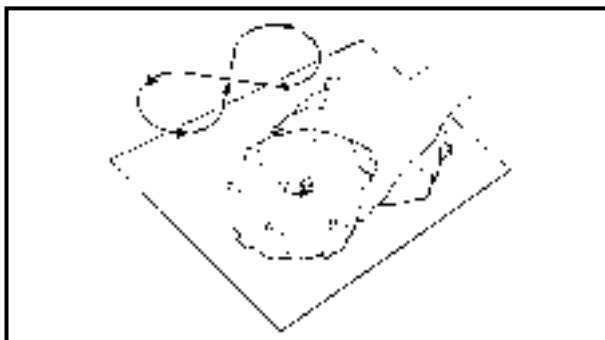

NOTE: Place a 400–600 grit wet sandpaper on a surface plate and resurface the cylinder head using a figure-eight sanding pattern.

**CYLINDERS
EXPLODED DIAGRAM**

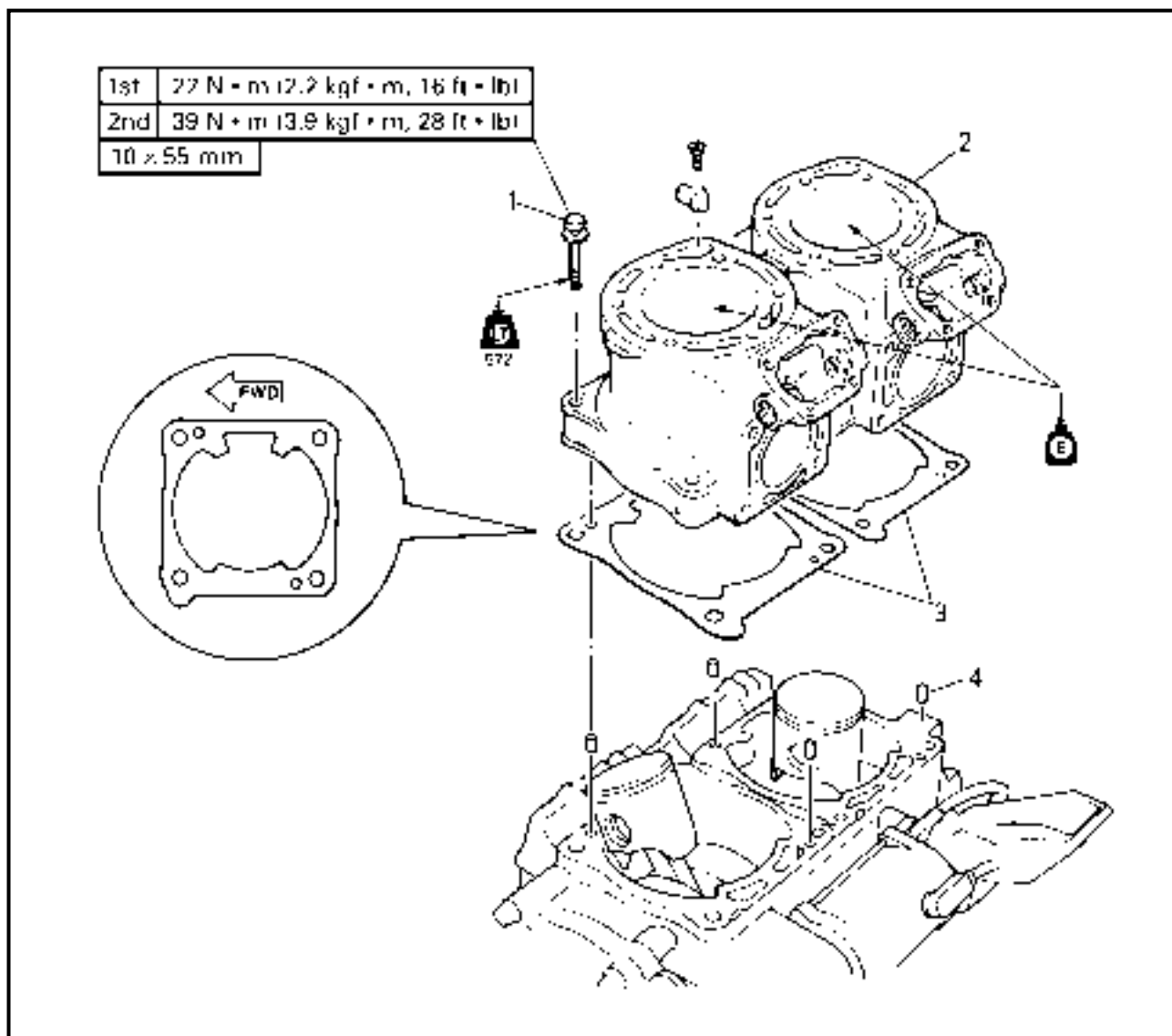

REMOVAL AND INSTALLATION CHART

Step	Procedure/Part name	Q'ty	Service points
CYLINDER REMOVAL			
YPVS			
Cylinder head			
1	Bolt	8	Follow the left "Step" for removal. Refer to "YPVS". Refer to "CYLINDER HEAD". NOTE: _____ Tighten the bolts in a crisscross pattern and in two stages.
2	Cylinder	2	NOTE: _____ Install the original position.
3	Cylinder gasket	2	Not reusable
4	Pin	4	
Reverse the removal steps for installation.			

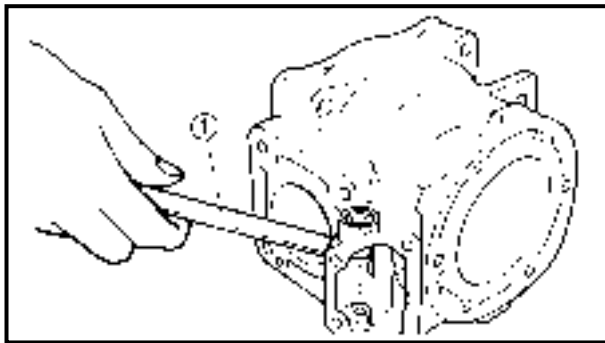

SERVICE POINTS

Cylinder inspection

1. Eliminate:
 - Carbon deposits
(with a rounded scraper ①)

2. Inspect:
 - Cylinder water jacket
Corrosion/mineral deposits → Clean or replace.
 - Cylinder inner surface
Score marks → Replace.

3. Measure:
 - Cylinder bore "D"
(with a cylinder gauge)
Out of specification → Replace cylinder and piston as a set.

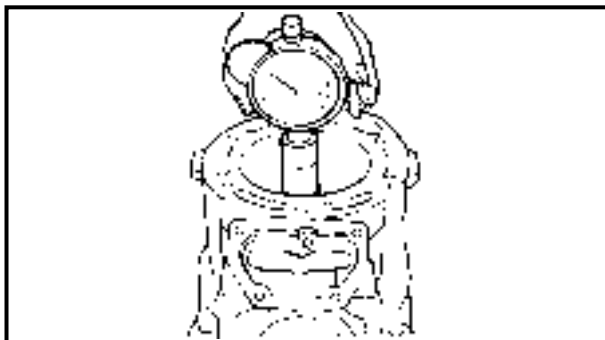

NOTE: _____

Measure the cylinder bore in parallel and at a right angle to the crankshaft. Then, average the measurements.

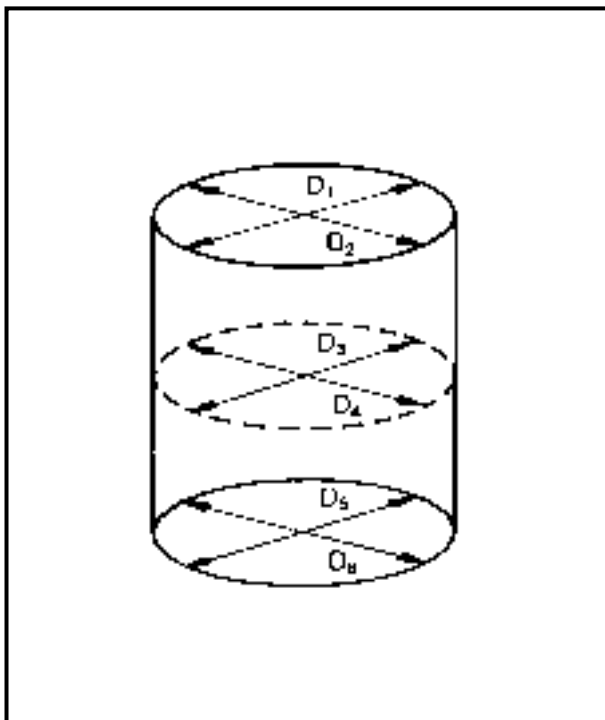

	Standard	Limit
Cylinder bore "D"	80.000–80.018 mm (3.1496–3.1503 in)	Original cylinder bore + 0.04 mm (0.0016 in)
Taper "T"	—	0.08 mm (0.003 in)
Out of round "R"	—	0.05 mm (0.002 in)
D = Maximum (D ₁ –D ₆) T = (Maximum D ₁ or D ₂) – (Maximum D ₅ or D ₆) R = (Maximum D ₁ , D ₃ or D ₅) – (Minimum D ₂ , D ₄ or D ₆)		

**PISTONS
EXPLODED DIAGRAM**

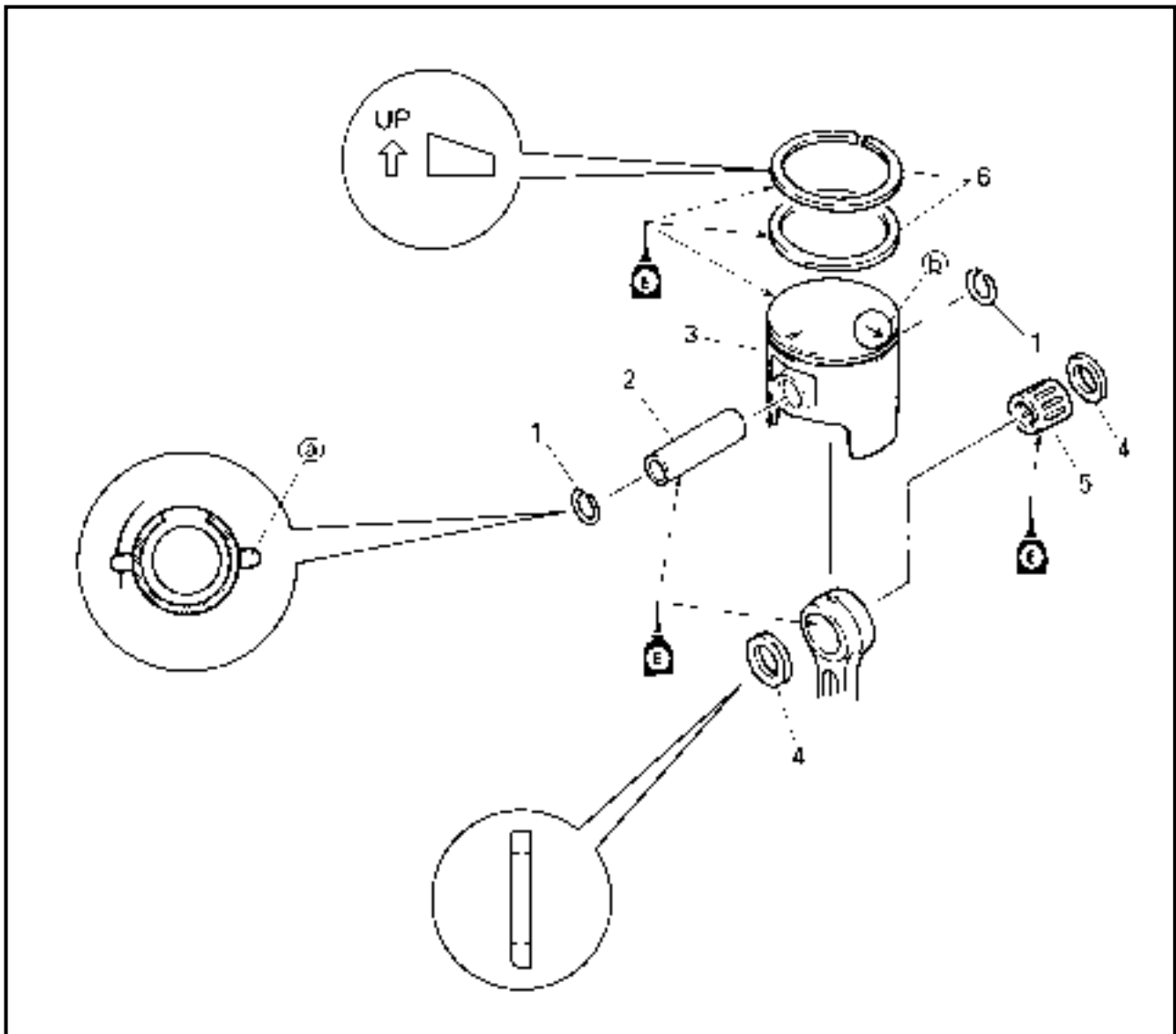

REMOVAL AND INSTALLATION CHART

Step	Procedure/Part name	Q'ty	Service points
	PISTON REMOVAL		
1	Cylinders Piston pin clip	2	Follow the left "Step" for removal. Refer to "CYLINDERS". CAUTION: _____ Do not align the open end of the clip with the piston pin slot ①. _____
2	Piston pin	1	
3	Piston	1	NOTE: _____
4	Washer	2	Make sure that the arrow ② faces towards the exhaust side. _____

EXPLODED DIAGRAM

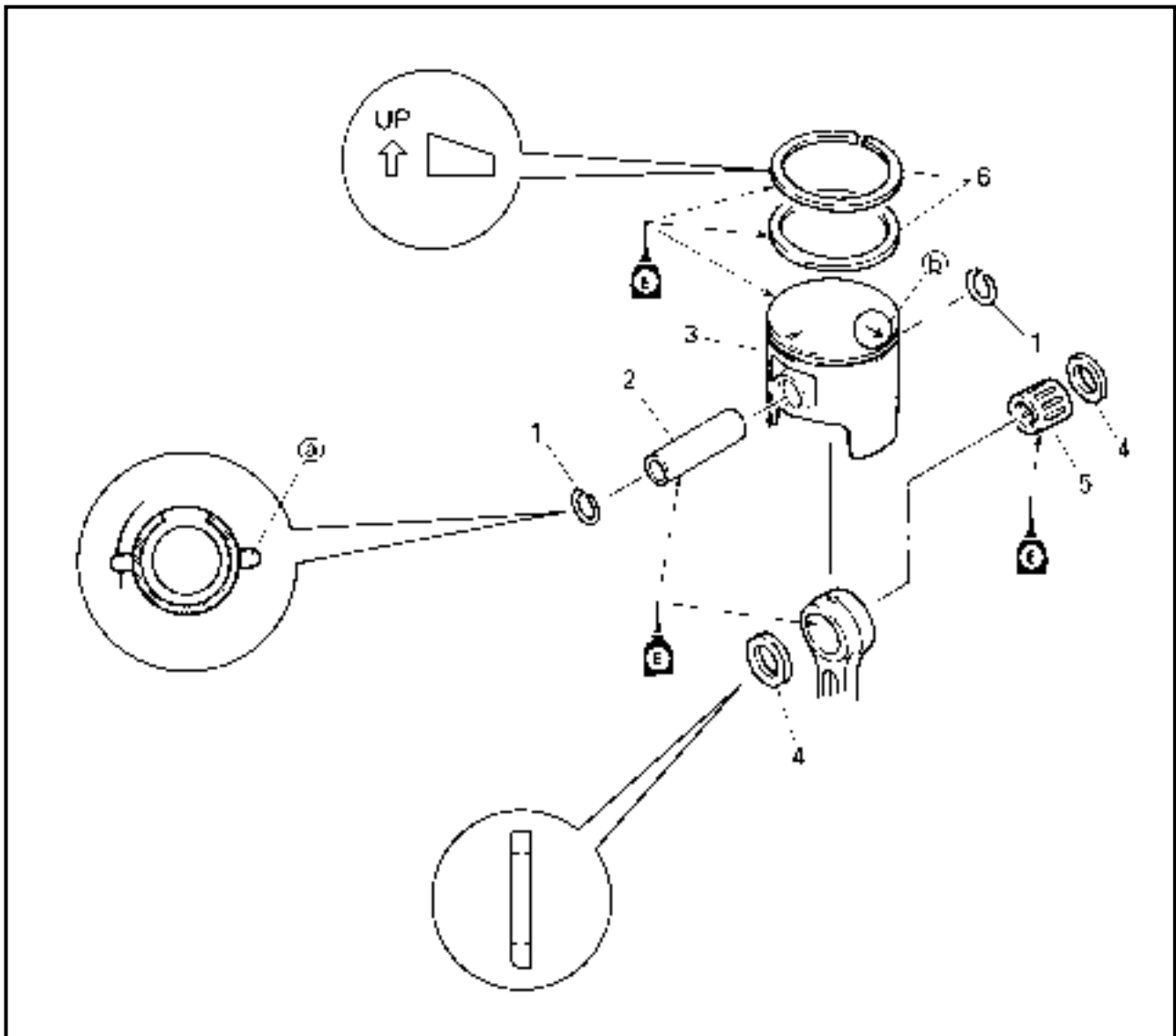

Step	Procedure/Part name	Q'ty	Service points
5	Bearing	1	<p>CAUTION: _____</p> <p>Align each end gap with its respective locating pin.</p> <p>_____</p> <p>Reverse the removal steps for installation.</p>
6	Piston ring	2	

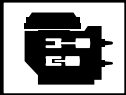

SERVICE POINTS

Piston pin clip removal and installation

1. Remove and install:
 - Piston pin clip

NOTE: _____

Before removing or installing the piston pin clip, cover the crankcase opening with a clean rag to prevent the piston pin clip from falling into the crankcase.

Piston inspection

1. Eliminate:
 - Carbon deposits
(from the piston crown and piston ring grooves)

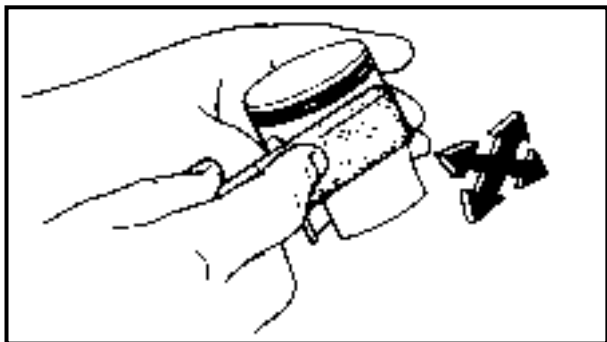

2. Inspect:
 - Piston wall
Score marks → Repair with 600–800 grit wet sandpaper or replace.

NOTE: _____

Lightly sand the piston wall in a crisscross pattern.

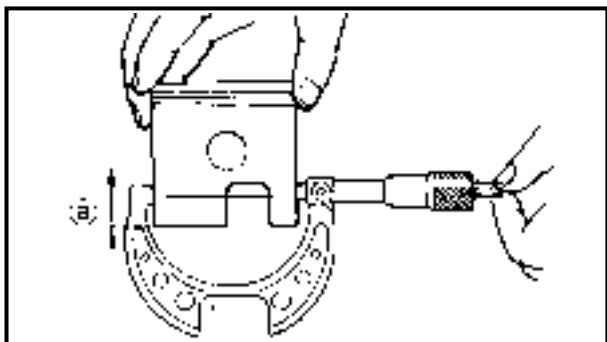

3. Measure:
 - Piston skirt diameter
(with a micrometer)
Out of specification → Replace.

	Piston diameter	Distance [Ⓐ]
	79.899–79.914 mm (3.1456–3.1462 in)	22 mm (0.87 in)



4. Calculate:

- Piston-to-cylinder clearance
Out of specification → Replace the piston, piston rings and cylinder as a set.

$$\text{PISTON CLEARANCE} = \text{CYLINDER BORE} - \text{PISTON DIAMETER}$$



Piston-to-cylinder clearance:
0.100–0.105 mm
(0.0039–0.0041 in)

Cylinder and piston combination

Select the appropriate piston to match the cylinder size by the table as follows.

Cylinder size indication ①	Piston color mark
0–5	Red
6–10	Orange
11–15	Green
16–18	Purple

NOTE:

New cylinder bore size = 80.000 + ①/1,000
Example: ① = 12 → 80.012 mm.

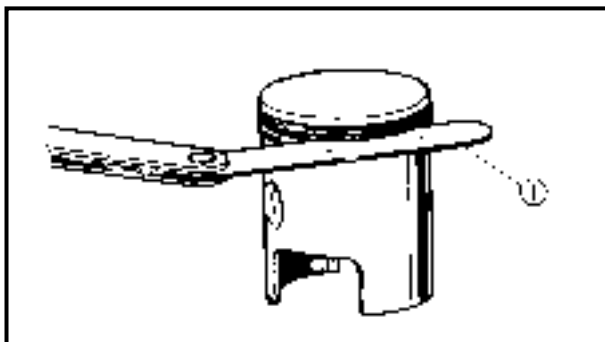
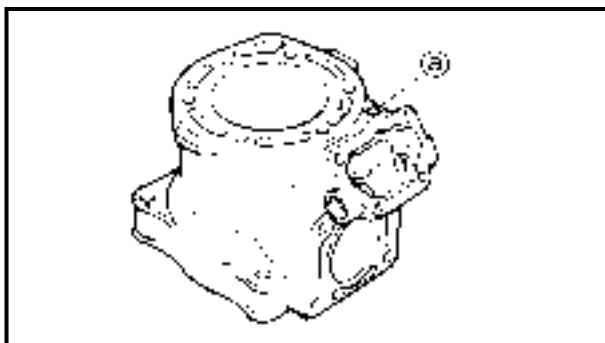

Piston ring inspection

- Measure:
 - Side clearance
(with a thickness gauge ①)
Out of specification → Replace the piston and piston rings as a set.



Side clearance:
0.03–0.05 mm (0.001–0.002 in)

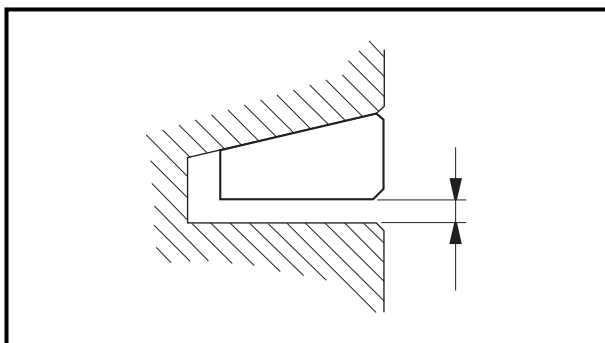

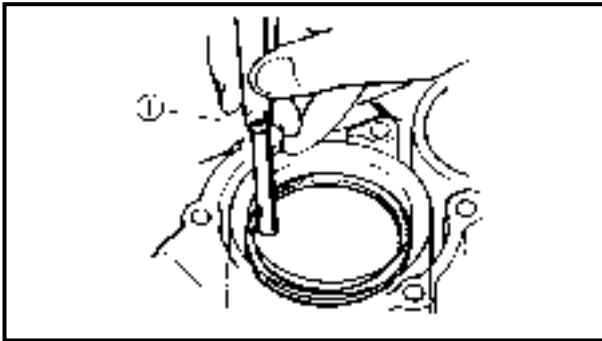

2. Measure:

- End gap
(with a thickness gauge ①)
Out of specification → Replace the piston rings as a set.



End gap:
0.30–0.45 mm (0.012–0.018 in)

NOTE: _____
Push the piston ring into the cylinder with the piston crown.

Piston pin and bearing inspection

1. Inspect:

- Piston pins
- Bearings
Signs of heat discoloration → Replace.

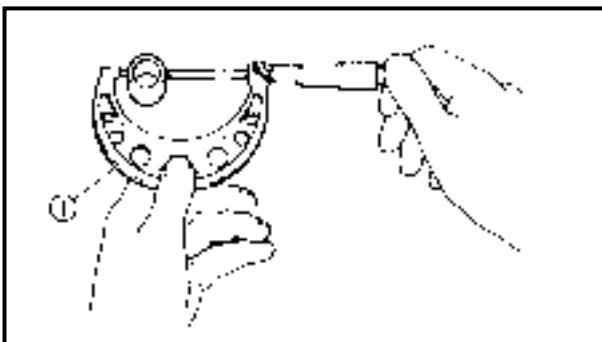

2. Measure:

- Piston pin outside diameter
(with a micrometer ①)
Out of specification → Replace.



Piston pin outside diameter:
Standard:
21.995–22.000 mm
(0.8659–0.8661 in)
Limit:
21.990 mm (0.8657 in)

3. Check:

- Piston pin-to-piston free play
(with the piston pin in the piston as shown)
Free play → Replace the piston pin, piston or both.

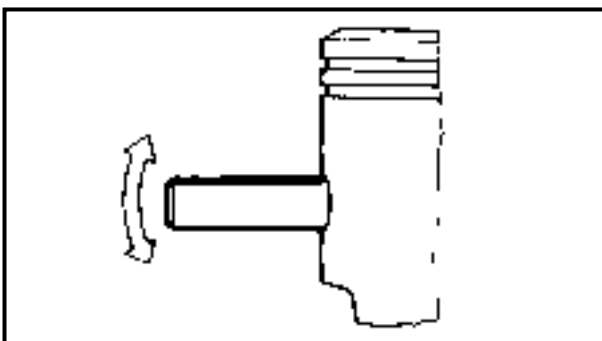

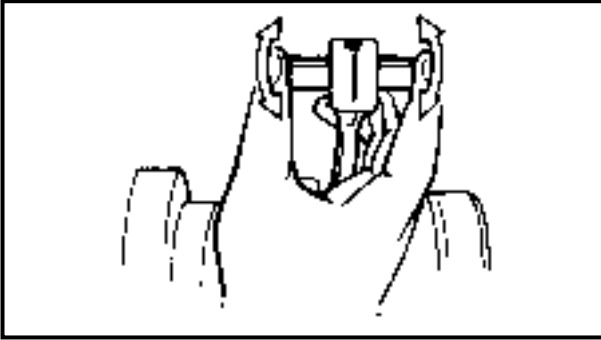

4. Check:

- Piston pin-to-small end bearing-to-connecting rod free play (at the small end of the connecting rod as shown)

Free play/small end wear → Replace the piston pin, connecting rod, or small end bearing.



**STARTER MOTOR
EXPLODED DIAGRAM**

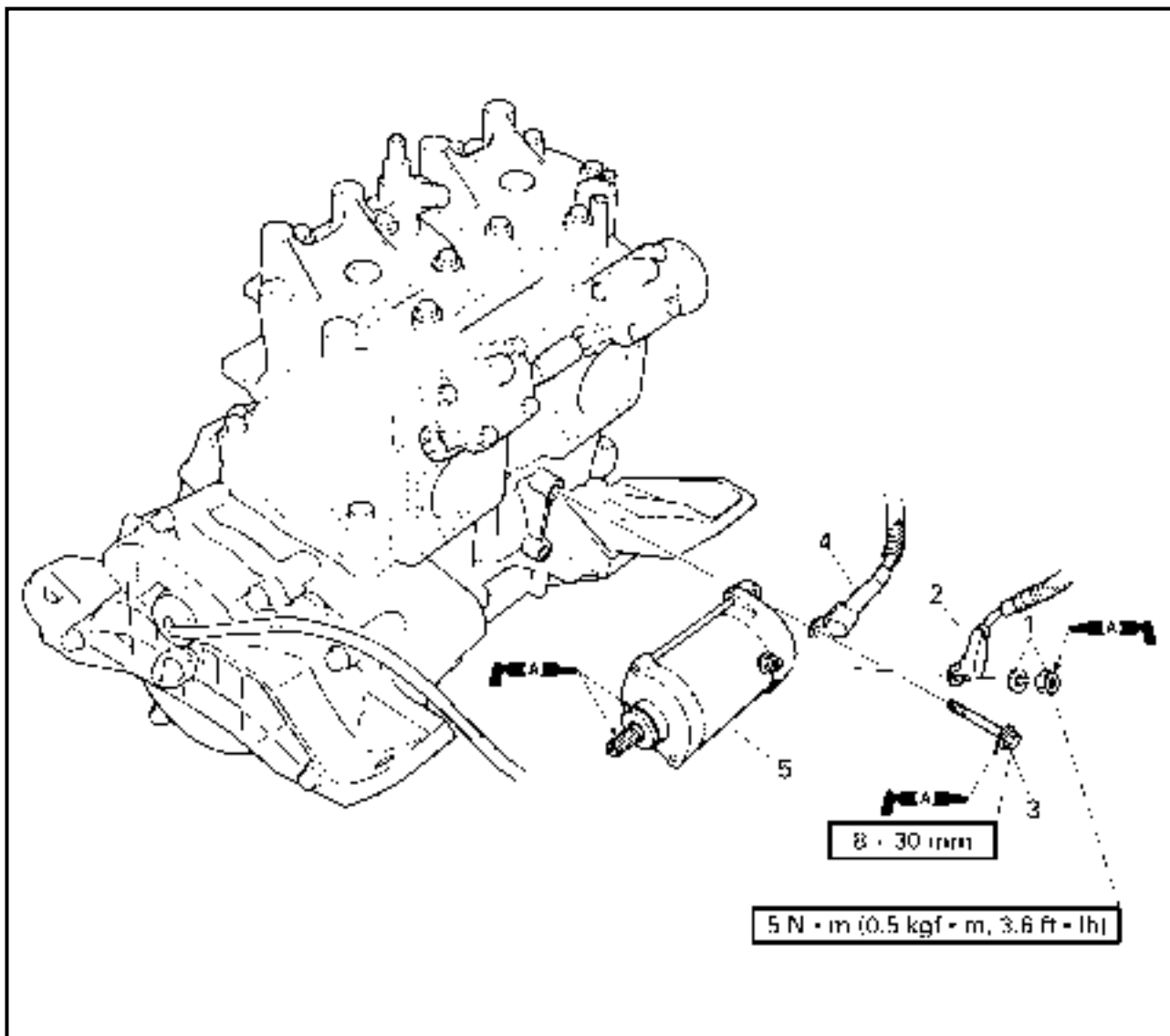

REMOVAL AND INSTALLATION CHART

Step	Procedure/Part name	Q'ty	Service points
	STARTER MOTOR REMOVAL		
	Engine unit		Follow the left "Step" for removal. Refer to "ENGINE UNIT".
1	Nut/washer	1/1	
2	Starter motor lead	1	
3	Bolt	2	
4	Battery negative lead	1	
5	Starter motor	1	
			Reverse the removal steps for installation.

**FLYWHEEL MAGNETO
EXPLODED DIAGRAM**

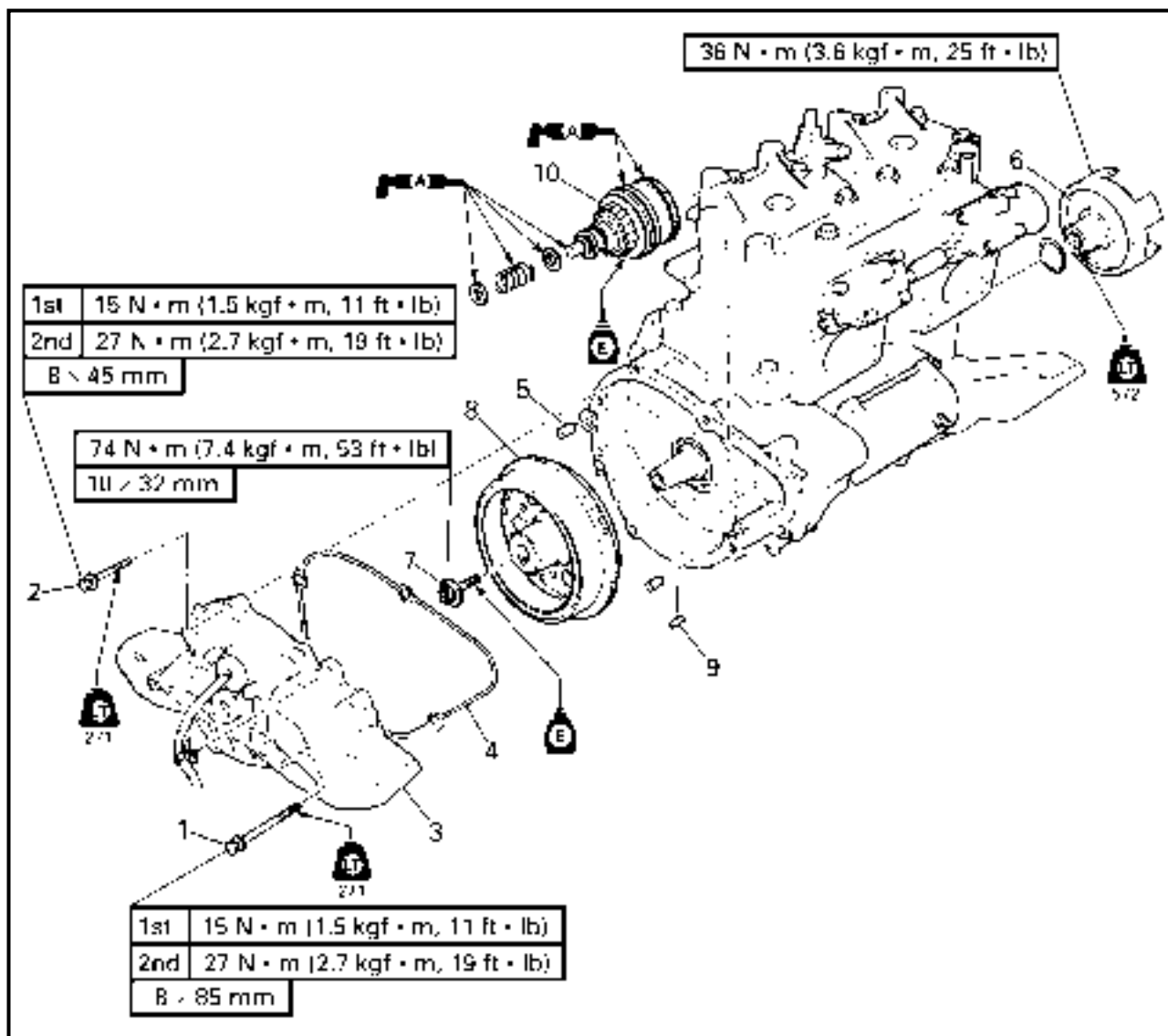

REMOVAL AND INSTALLATION CHART

Step	Procedure/Part name	Q'ty	Service points
	FLYWHEEL MAGNETO REMOVAL		Follow the left "Step" for removal.
	Engine unit		Refer to "ENGINE UNIT".
	Oil pump		Refer to "OIL PUMP" in chapter 4.
1	Bolt	2	
2	Bolt	6	
3	Generator cover	1	
4	Packing	1	
5	Pin	2	

EXPLODED DIAGRAM

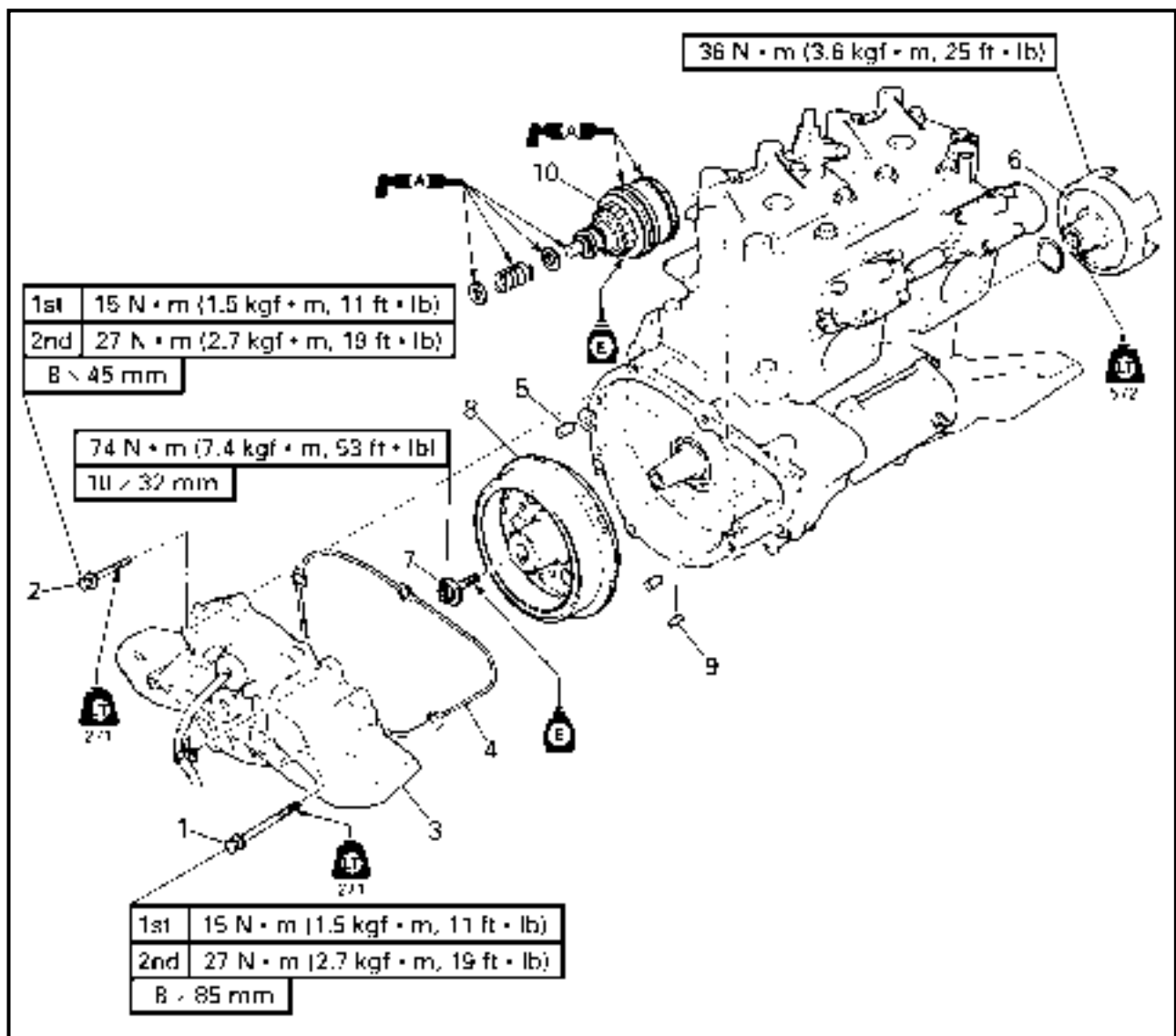

Step	Procedure/Part name	Q'ty	Service points
6	Drive coupling	1	Reverse the removal steps for installation.
7	Bolt	1	
8	Flywheel magneto	1	
9	Woodruff key	1	
10	Starter clutch assembly	1	



EXPLODED DIAGRAM

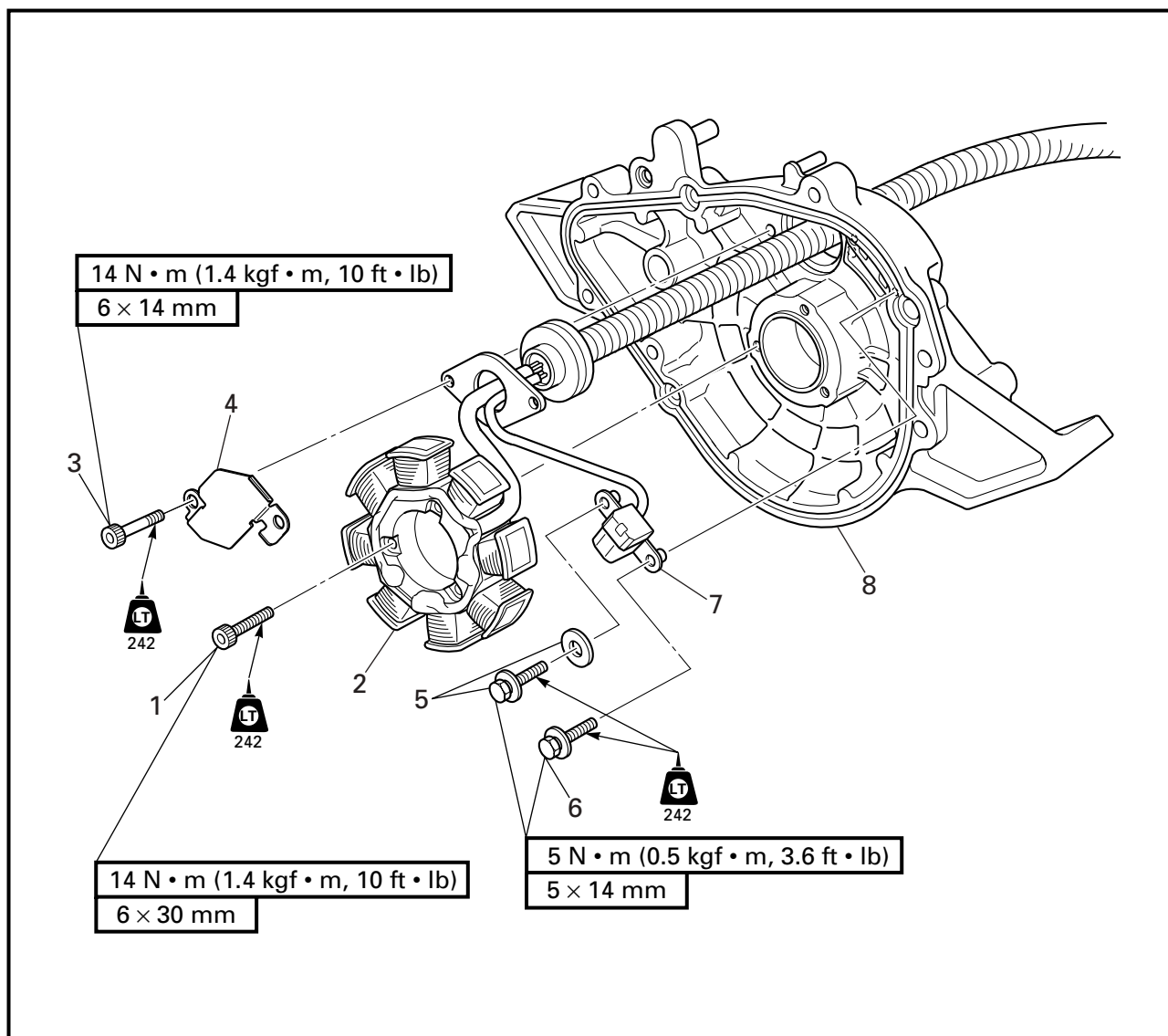

REMOVAL AND INSTALLATION CHART

Step	Procedure/Part name	Q'ty	Service points
	GENERATOR COVER DISASSEMBLY		Follow the left "Step" for disassembly.
1	Bolt	3	
2	Stator coil	1	
3	Bolt	2	
4	Cable holder	1	NOTE: _____
5	Bolt/washer	1/1	This washer holds the pickup coil lead.
6	Bolt	1	Make sure to not pinch the lead between the projection and the washer when installing the bolt.
7	Pickup coil	1	
8	Generator cover	1	Reverse the disassembly steps for assembly.



EXPLODED DIAGRAM

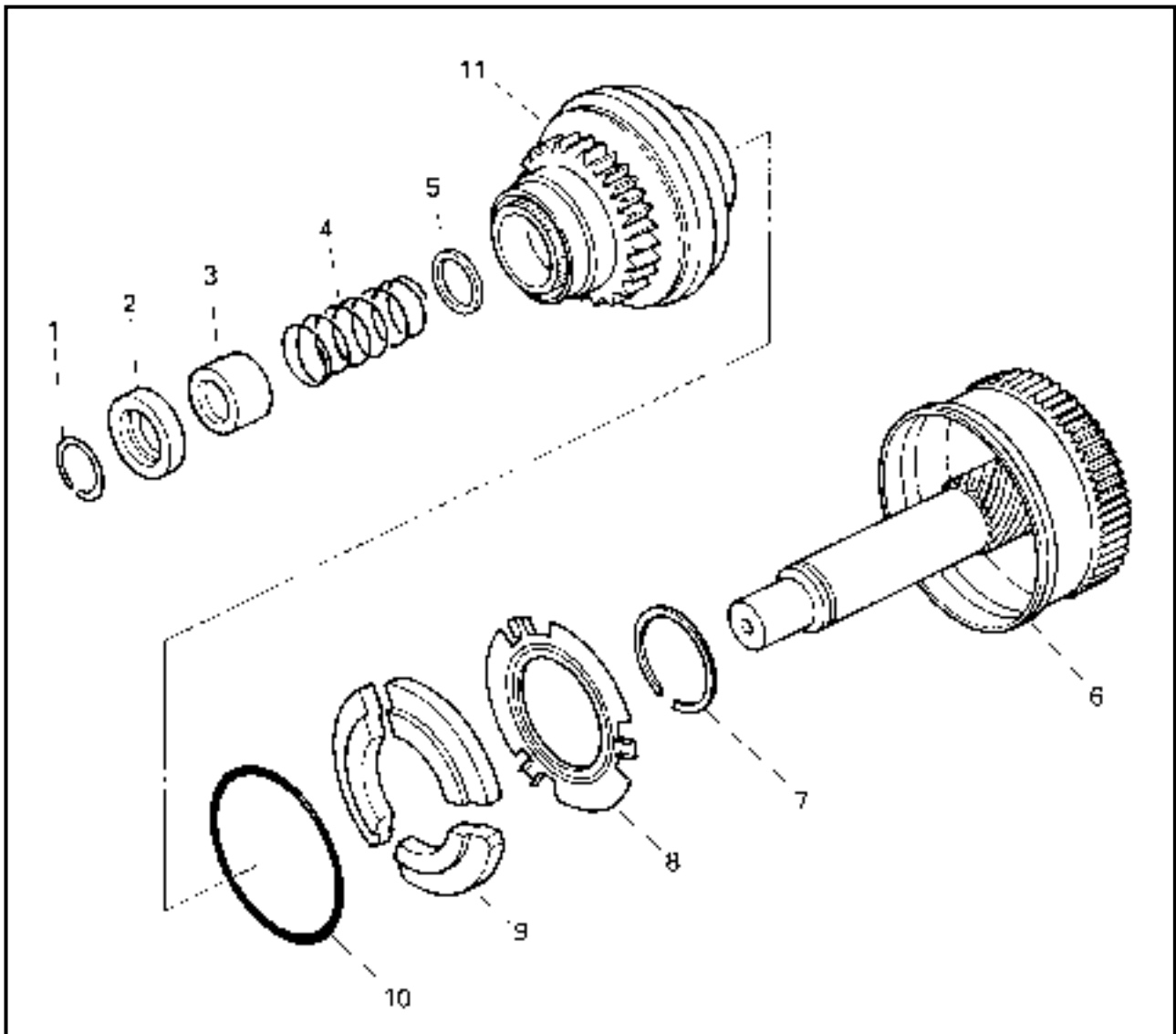

REMOVAL AND INSTALLATION CHART

Step	Procedure/Part name	Q'ty	Service points
	STARTER CLUTCH DISASSEMBLY		Follow the left "Step" for disassembly.
1	Clip	1	Not reusable
2	Clip stopper	1	
3	Spring seat	1	
4	Spring	1	
5	Washer	1	
6	Idle gear	1	
7	Circlip	1	



EXPLODED DIAGRAM

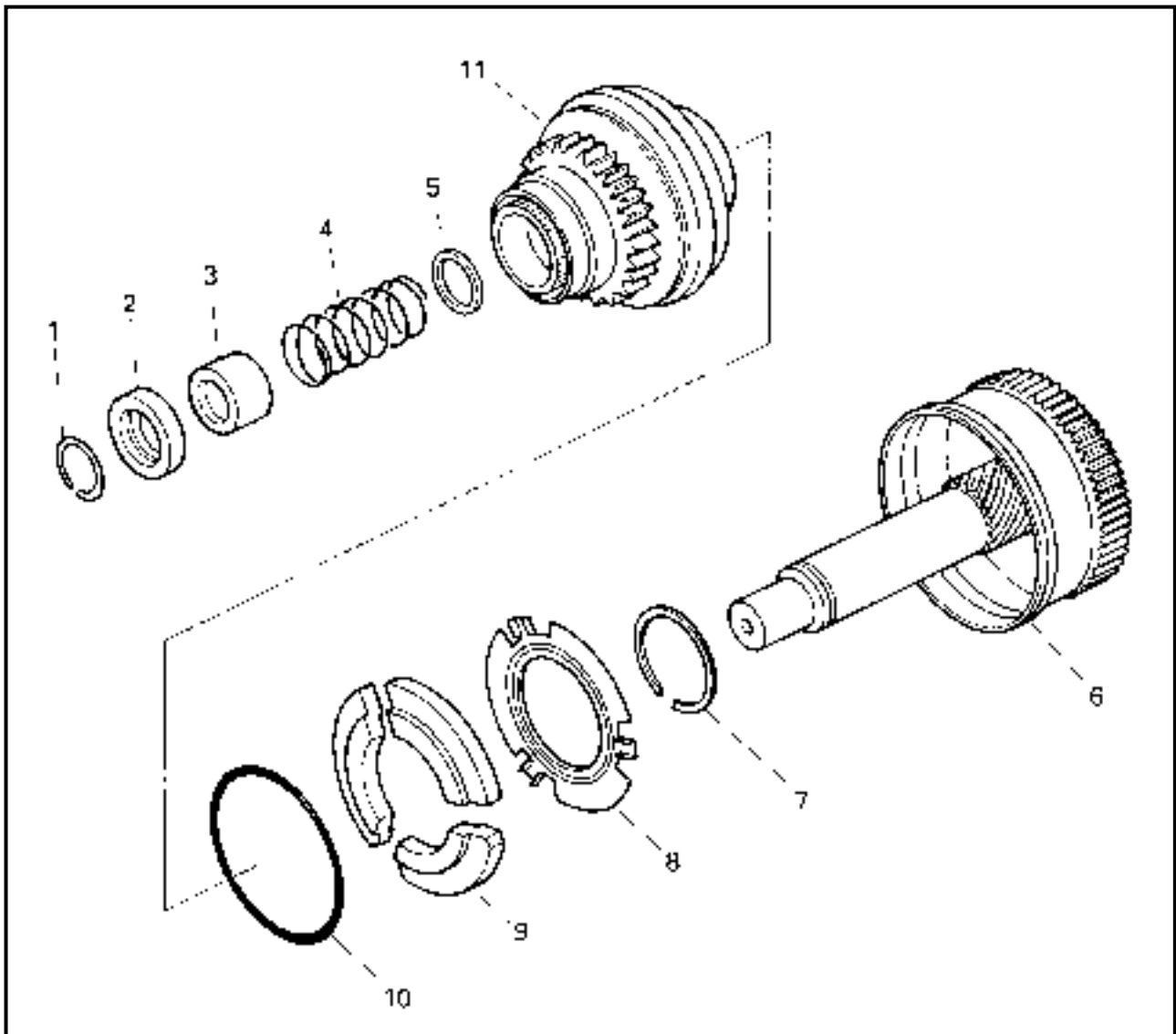

Step	Procedure/Part name	Q'ty	Service points
8	Plate	1	<p>NOTE: _____ Install the spring ring after installing the weights, plate and circlip.</p>
9	Weight	3	
10	Spring ring	1	
11	Pinion gear	1	<p>Reverse the disassembly steps for assembly.</p>

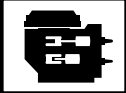

SERVICE POINTS

Drive coupling removal and installation

1. Remove:
 - Drive coupling



Coupler wrench:
YW-06551/90890-06551
Flywheel holder:
YW-06550/90890-06550

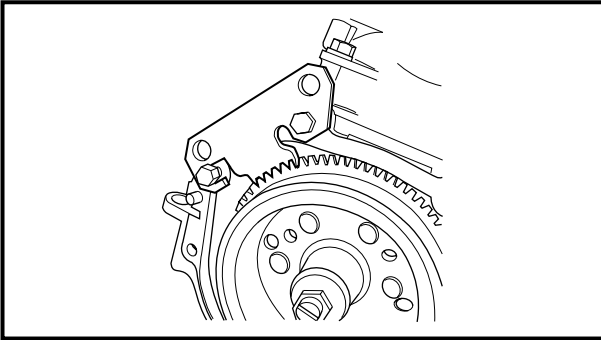

NOTE: _____
 Install the drive coupling with the same special tools that were used for removal.

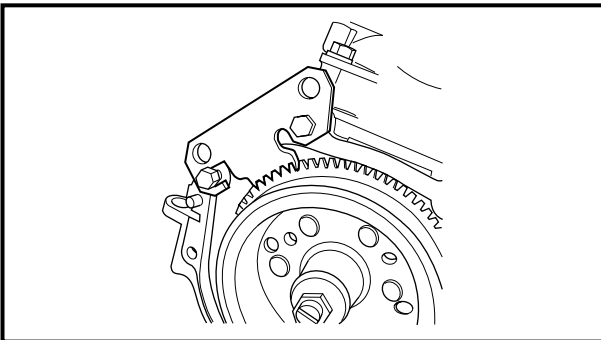

Flywheel magneto removal and installation

1. Remove:
 - Flywheel magneto bolt



Flywheel holder:
YW-06550/90890-06550

NOTE: _____
 Install the bolt with the same special tool that was used for removal.

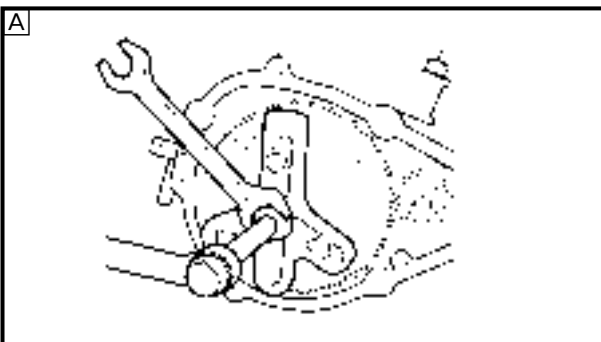

2. Remove:
 - Flywheel magneto



Flywheel puller:
YB-06117/90890-06521
Set bolt:
M8 × 60 mm

- [A] For USA and Canada
- [B] For worldwide

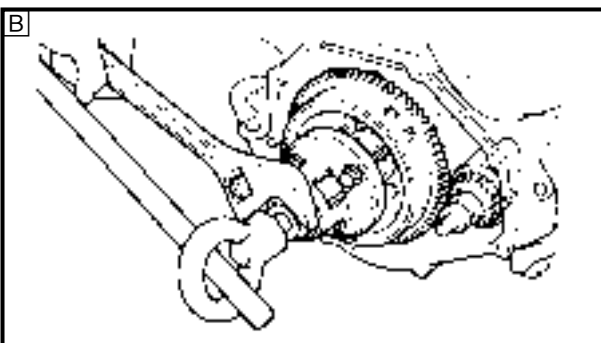

CAUTION: _____
To prevent damage to the engine or tools, screw in the flywheel puller set bolts evenly and completely so that the puller plate is parallel to the flywheel magneto.

**Drive coupling inspection**

1. Inspect:
 - Drive coupling
Damage/wear → Replace.

Flywheel magneto inspection

1. Inspect:
 - Ring gear
Damage/wear → Replace.

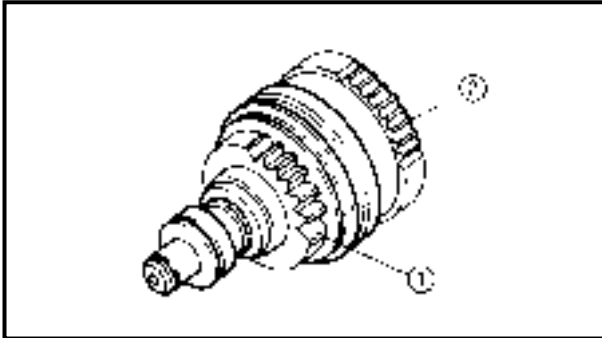
**Starter clutch assembly inspection**

1. Inspect:
 - Pinion gear ①
 - Idle gear ②
Damage/wear → Replace.
2. Check:
 - Gear movement
Rough movement → Replace the defective part(s).

**CRANKCASE
EXPLODED DIAGRAM**

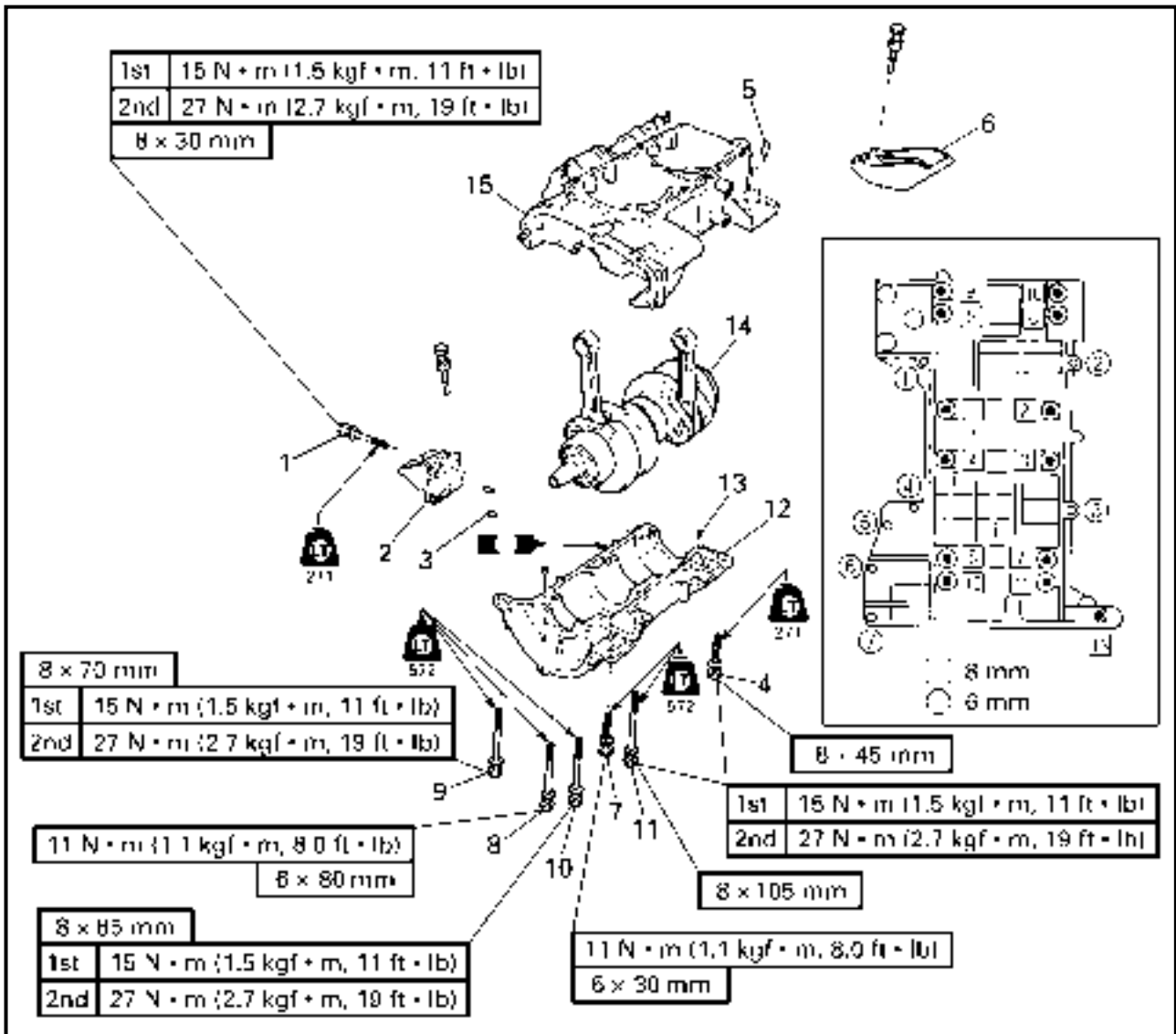

REMOVAL AND INSTALLATION CHART

Step	Procedure/Part name	Q'ty	Service points
	CRANKCASE DISASSEMBLY		Follow the left "Step" for disassembly.
	Pistons		Refer to "PISTONS".
	Starter motor		Refer to "STARTER MOTOR".
	Generator cover		Refer to "FLYWHEEL MAGNETO".
1	Bolt	3	
2	Mount bracket 1	1	
3	Pin	2	
4	Bolt	3	
5	Pin	2	
6	Mount bracket 2	1	
7	Bolt	4	



EXPLODED DIAGRAM

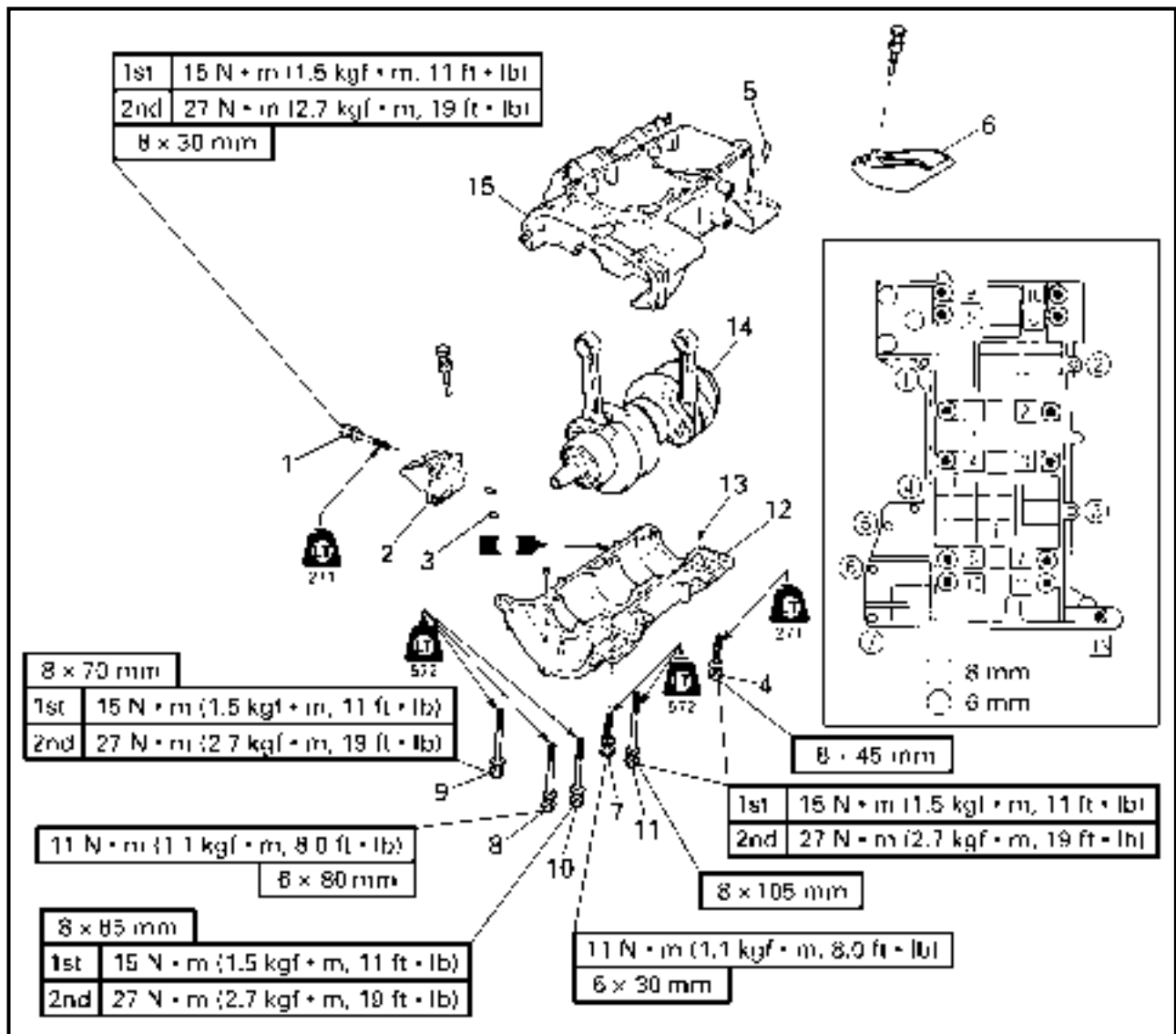

Step	Procedure/Part name	Q'ty	Service points
8	Bolt	3	<p>NOTE: _____</p> <p>Tighten the bolts in sequence as shown.</p> <p>_____</p> <p>Reverse the disassembly steps for assembly.</p>
9	Bolt	1	
10	Bolt	10	
11	Bolt	2	
12	Lower crankcase	1	
13	Pin	2	
14	Crankshaft assembly	1	
15	Upper crankcase	1	



SERVICE POINTS

Crankcase inspection

1. Inspect:

- Mating surfaces
Scratches → Replace the crankcase.
- Crankcase
Cracks/damage → Replace.

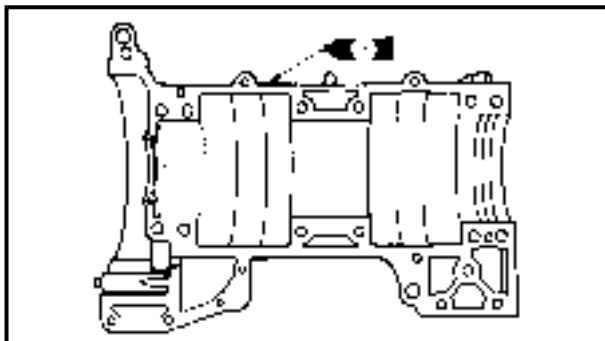

Crankcase installation

1. Apply:

- Gasket Maker®
(onto the crankcase mating surfaces)

NOTE: _____

Before applying Gasket Maker®, clean the crankcase mating surfaces.

2. Check:

- Crankshaft
Rough movement → Recheck.

NOTE: _____

Make sure that the crankshaft rotates smoothly after installing it.

**CRANKSHAFT
EXPLODED DIAGRAM**

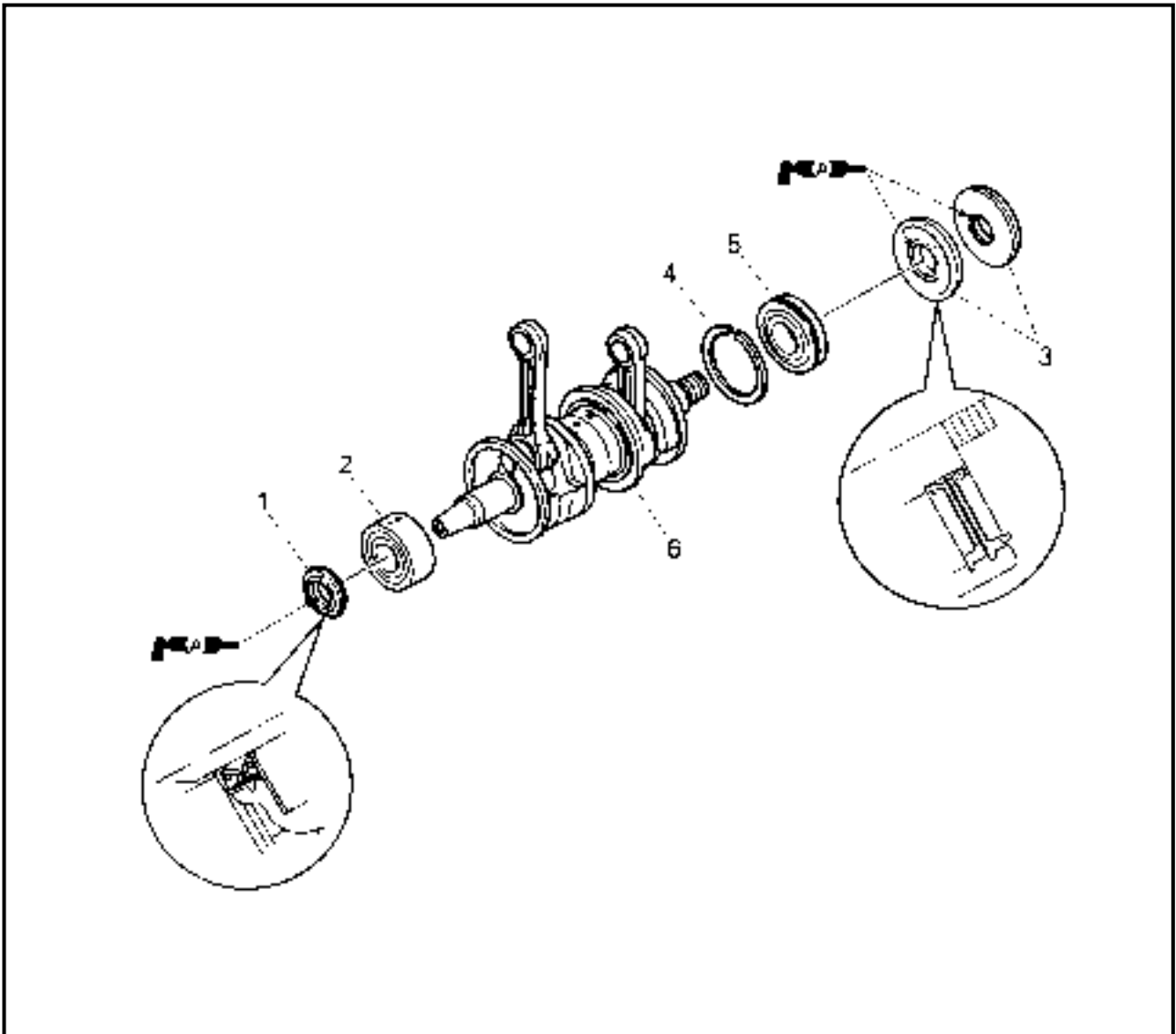

REMOVAL AND INSTALLATION CHART

Step	Procedure/Part name	Q'ty	Service points
	CRANKSHAFT REMOVAL		
	Crankcase		Follow the left "Step" for removal. Refer to "CRANKCASE".
1	Oil seal	1	
2	Bearing	1	
3	Oil seal	2	
4	Bearing clip	1	
5	Bearing	1	
6	Crankshaft	1	
			CAUTION: _____ Install the bearing locating pins into the grooves in the crankcase body. _____ Reverse the removal steps for installation.

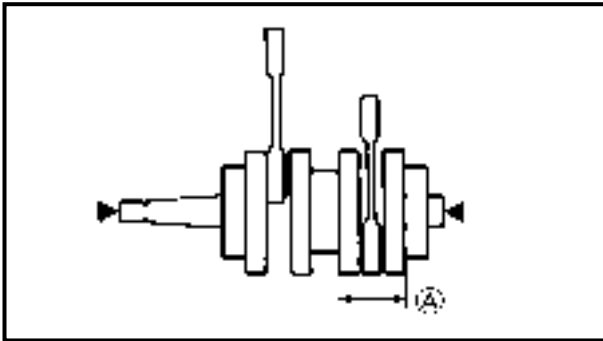

SERVICE POINTS

Crankshaft inspection

1. Measure:

- Crank width (A)

Out of specification → Replace.

	<p>Crank width: 72.95–73.00 mm (2.872–2.874 in)</p>
--	--

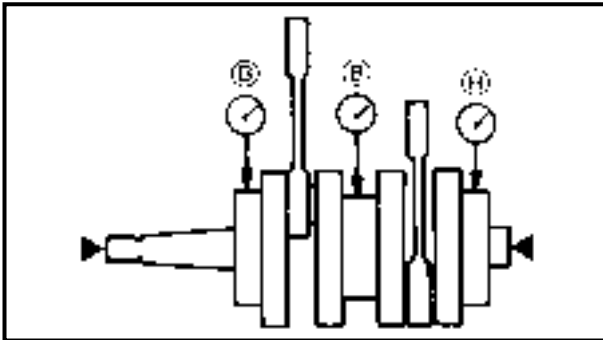

2. Measure:

- Deflection (B)

(with a dial gauge)

Out of specification → Replace.

	<p>Max. deflection: 0.05 mm (0.002 in)</p>
--	---

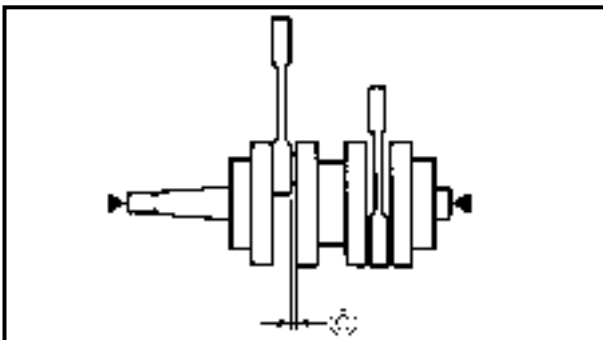

3. Measure:

- Big end side clearance (C)

(with a thickness gauge)

Out of specification → Replace.

	<p>Big end side clearance: 0.25–0.75 mm (0.010–0.030 in)</p>
--	---

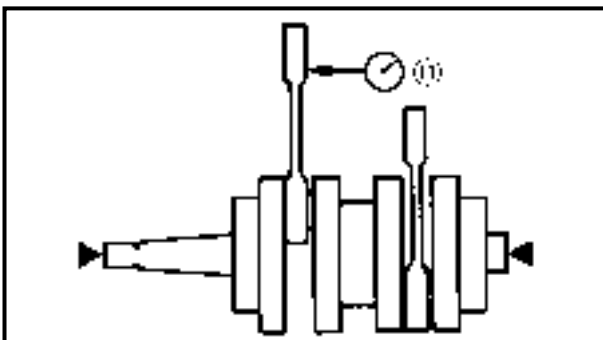

4. Measure:

- Small end free play (D)

(with a dial gauge)

Out of specification → Replace.

	<p>Small end free play: 2.0 mm (0.08 in)</p>
--	---

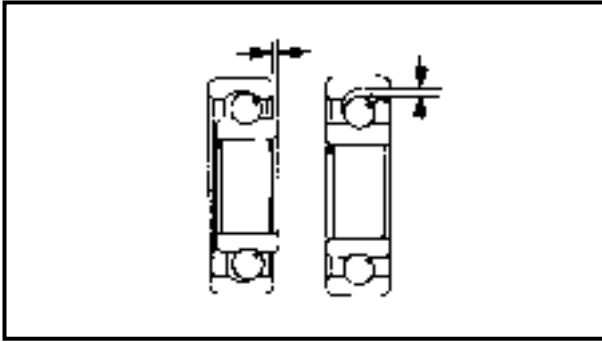

5. Inspect:

- Bearings
Damage/pitting → Replace.

NOTE: _____

- Before inspection, thoroughly clean the bearings.
- Immediately after inspection, lubricate the bearings to prevent rust.

6. Inspect:

- Oil seals
Damage/wear → Replace.

CHAPTER 6 JET PUMP UNIT

JET PUMP UNIT	6-1
EXPLODED DIAGRAM	6-1
REMOVAL AND INSTALLATION CHART	6-1
NOZZLE DEFLECTOR AND NOZZLE RING.....	6-4
EXPLODED DIAGRAM.....	6-4
REMOVAL AND INSTALLATION CHART	6-4
IMPELLER DUCT, IMPELLER HOUSING, AND INTAKE DUCT.....	6-5
EXPLODED DIAGRAM.....	6-5
REMOVAL AND INSTALLATION CHART	6-5
IMPELLER DUCT AND DRIVE SHAFT	6-7
EXPLODED DIAGRAM.....	6-7
REMOVAL AND INSTALLATION CHART	6-7
SERVICE POINTS	6-9
Drive shaft removal.....	6-9
Impeller inspection	6-10
Drive shaft inspection	6-10
Drive shaft installation.....	6-10
TRANSOM PLATE AND HOSES.....	6-13
EXPLODED DIAGRAM	6-13
REMOVAL AND INSTALLATION CHART	6-13
SERVICE POINTS	6-15
Bilge strainer inspection.....	6-15
Bilge hose inspection.....	6-15
BEARING HOUSING.....	6-16
EXPLODED DIAGRAM	6-16
REMOVAL AND INSTALLATION CHART	6-16
SERVICE POINTS	6-19
Driven coupling removal and installation.....	6-19
Intermediate drive shaft removal	6-19
Bearing removal.....	6-19
Bearing, driven coupling shaft, and grease hose inspection	6-20
Driven coupling inspection	6-20
Bearing installation	6-20
Oil seal installation.....	6-20
Intermediate housing installation.....	6-21



**JET PUMP UNIT
EXPLODED DIAGRAM**

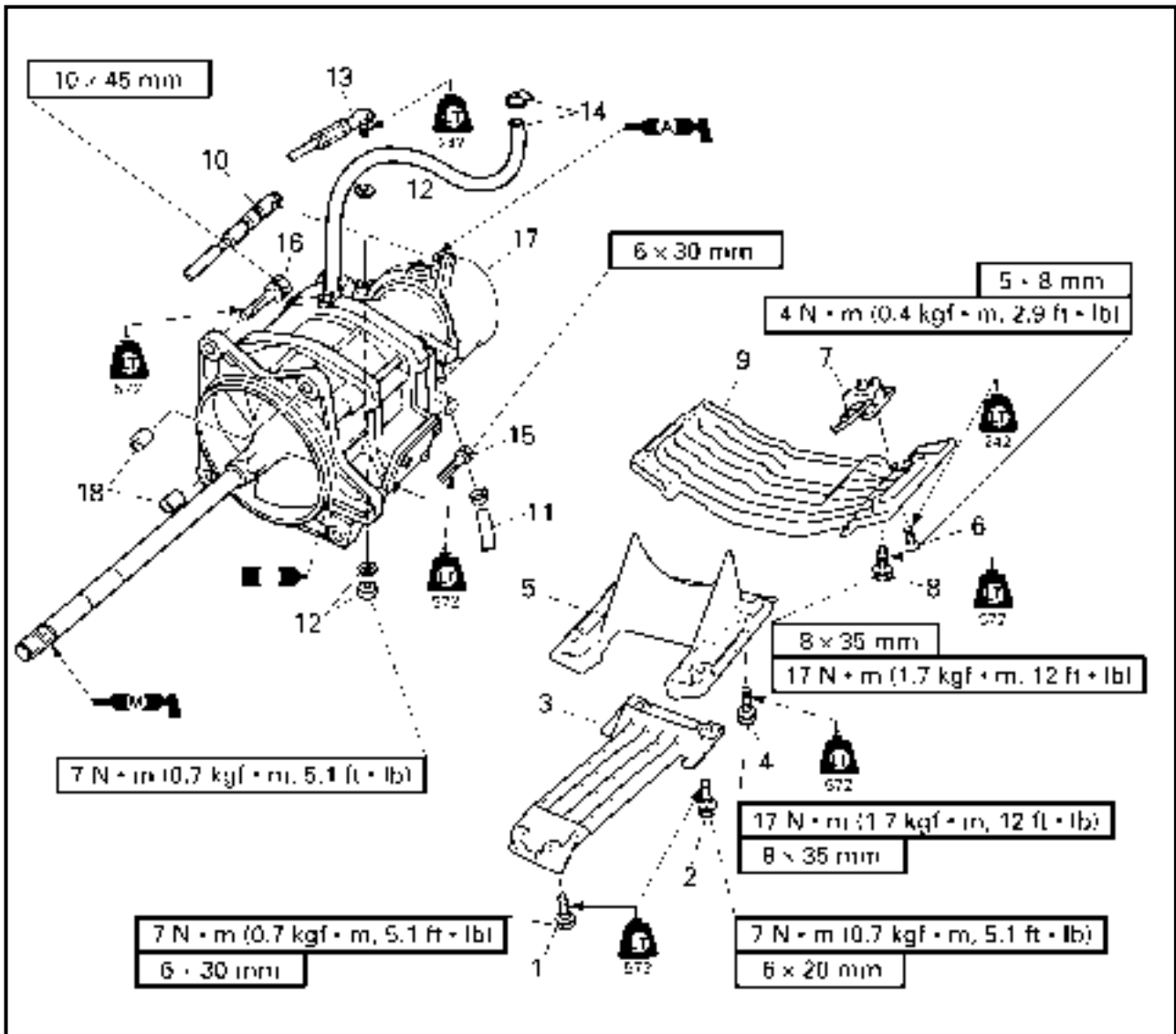

REMOVAL AND INSTALLATION CHART

Step	Procedure/Part name	Q'ty	Service points
JET PUMP UNIT REMOVAL			Follow the left "Step" for removal.
1	Bolt	2	
2	Bolt	2	
3	Intake grate	1	
4	Bolt	4	
5	Intake duct	1	
6	Screw	4	
7	Speed sensor	1	NOTE: _____ Route the speed sensor lead between the jet pump unit and the bilge hose.

EXPLODED DIAGRAM

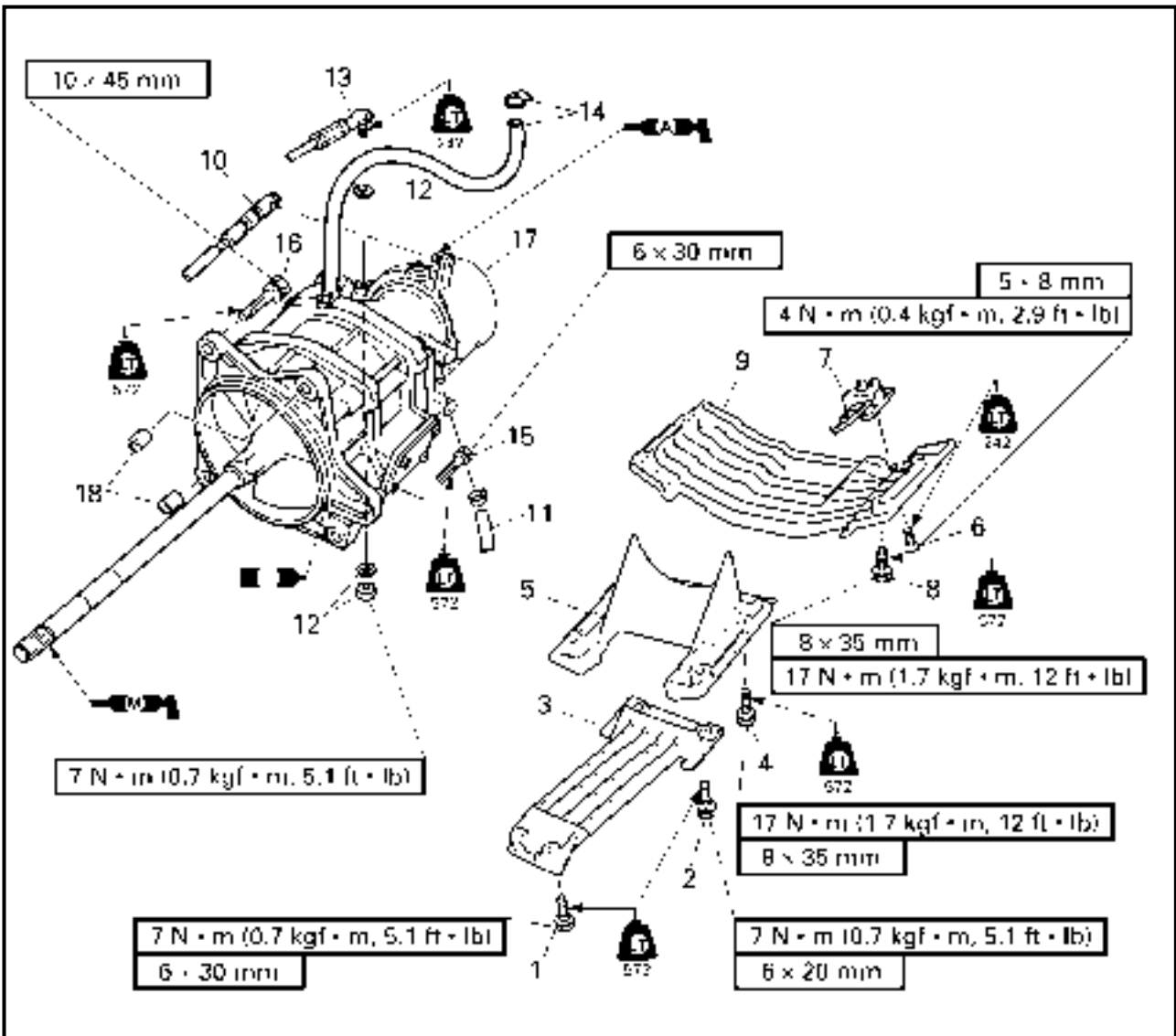

Step	Procedure/Part name	Q'ty	Service points
8	Bolt	4	
9	Ride plate	1	
10	QSTS cable joint	1	
11	Bilge hose	1	
12	Nut/washer	1/2	
13	Steering cable joint	1	
14	Clamp/spout hose	1/1	
15	Bolt	1	
16	Bolt	4	

EXPLODED DIAGRAM

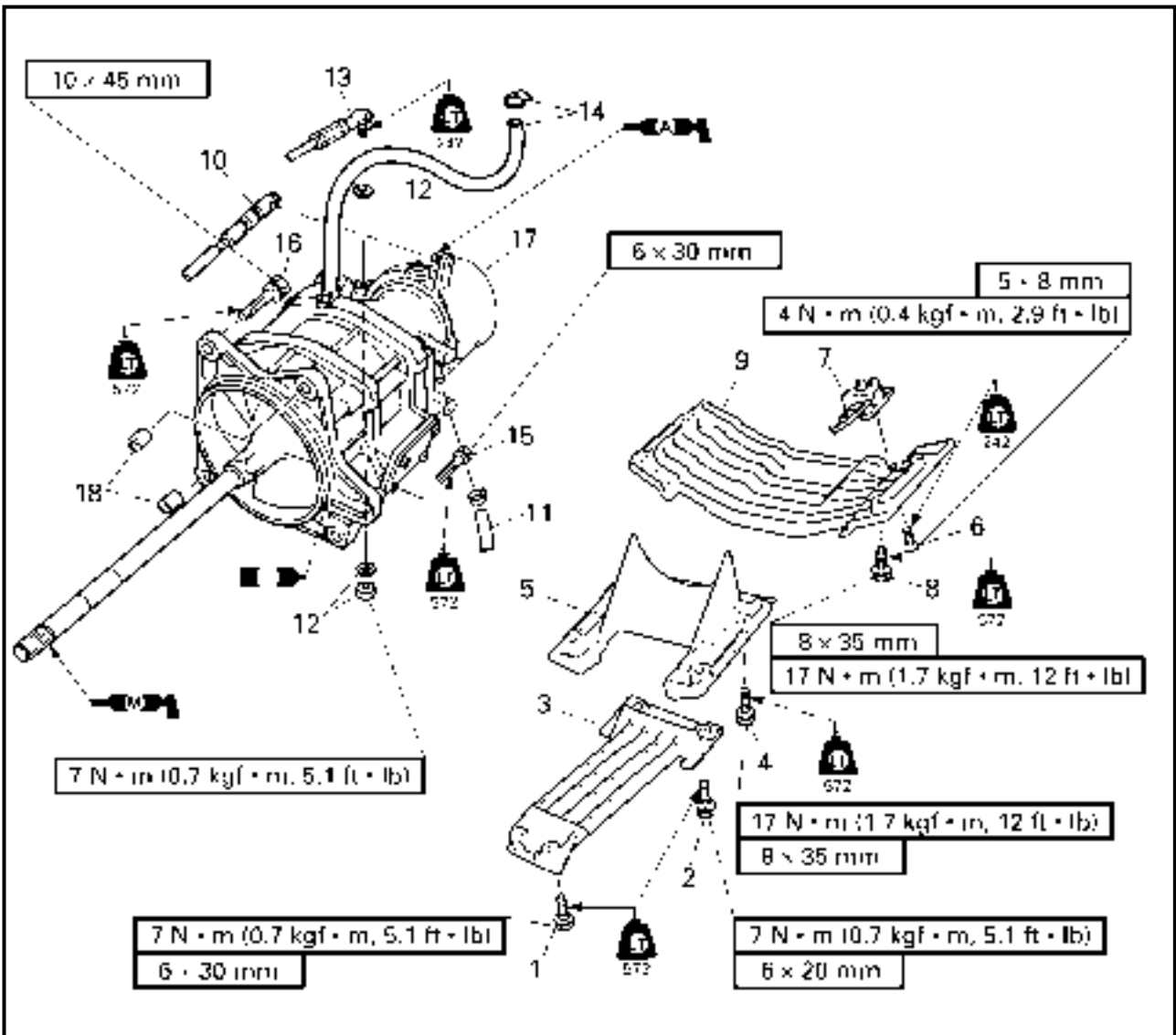

Step	Procedure/Part name	Q'ty	Service points
17	Jet pump unit assembly	1	NOTE: _____ ● Pull the jet pump unit straight back. ● When installing the jet pump unit, align the drive shaft spline (male) with the intermediate drive shaft spline (female). _____ Reverse the removal steps for installation.
18	Dowel pin	2	

**NOZZLE DEFLECTOR AND NOZZLE RING
EXPLODED DIAGRAM**

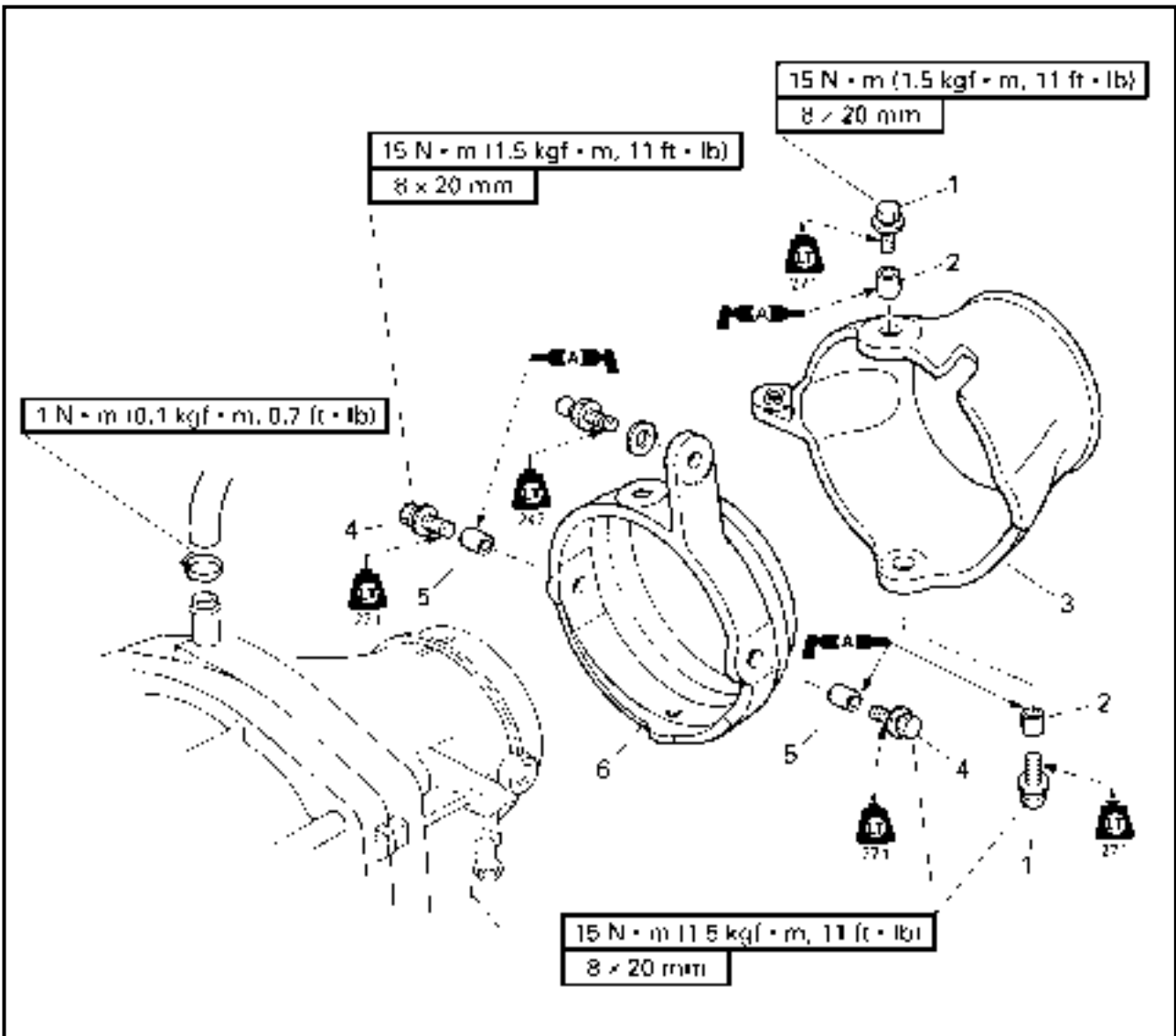

REMOVAL AND INSTALLATION CHART

Step	Procedure/Part name	Q'ty	Service points
	NOZZLE DEFLECTOR AND NOZZLE RING REMOVAL		Follow the left "Step" for removal.
	Jet pump unit		Refer to "JET PUMP UNIT".
1	Bolt	2	
2	Collar	2	
3	Nozzle deflector	1	
4	Bolt	2	
5	Collar	2	
6	Nozzle ring	1	
			Reverse the removal steps for installation.

IMPELLER DUCT, IMPELLER HOUSING, AND INTAKE DUCT EXPLODED DIAGRAM

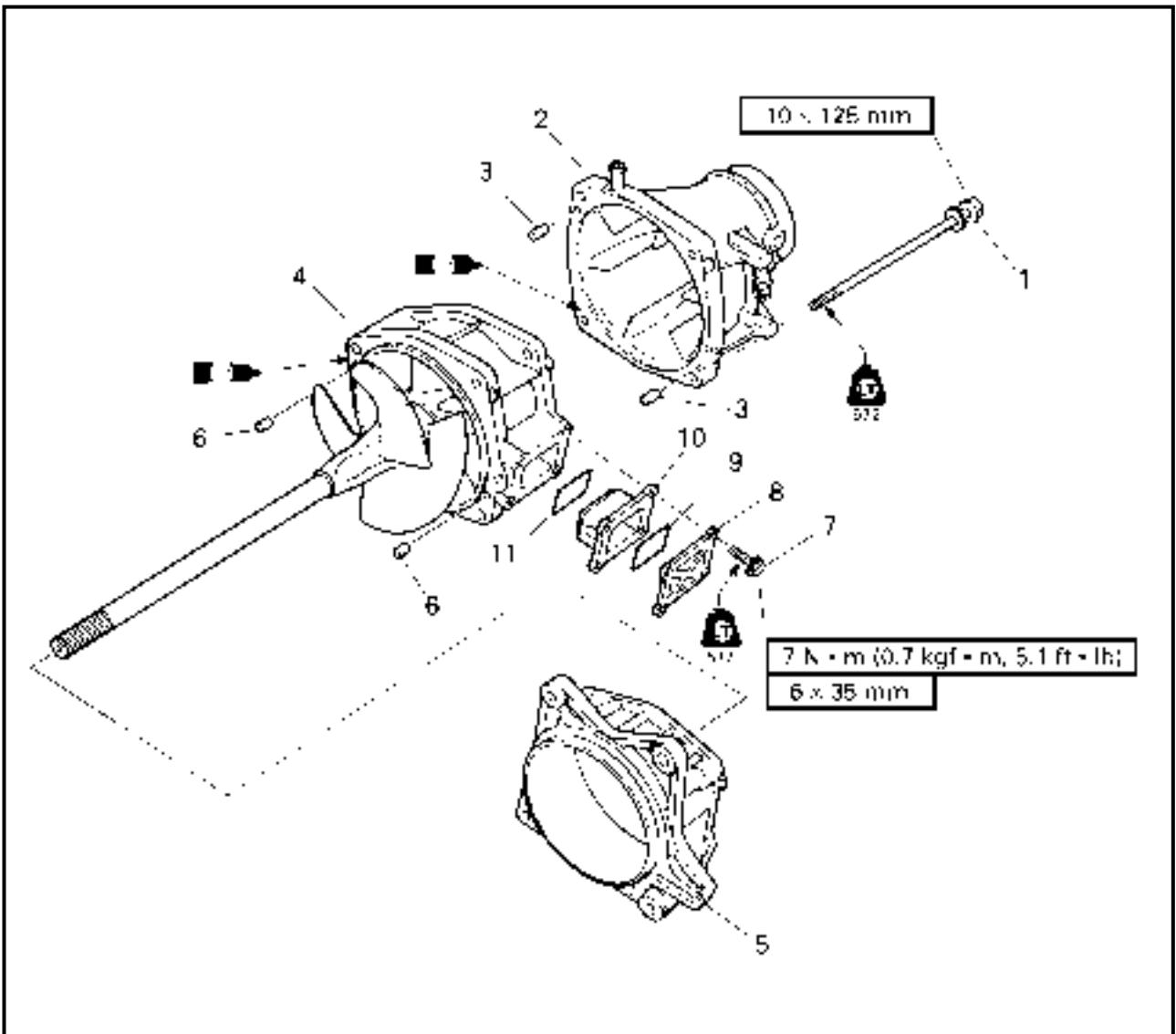

REMOVAL AND INSTALLATION CHART

Step	Procedure/Part name	Q'ty	Service points
	IMPELLER DUCT AND IMPELLER HOUSING REMOVAL		Follow the left "Step" for removal.
	Nozzle ring		Refer to "NOZZLE DEFLECTOR AND NOZZLE RING".
1	Bolt	4	NOTE: _____ Clean the matching surfaces before applying the Gasket Maker®.
2	Nozzle	1	
3	Pin	2	
4	Impeller duct assembly	1	
5	Impeller housing	1	
6	Pin	2	

EXPLODED DIAGRAM

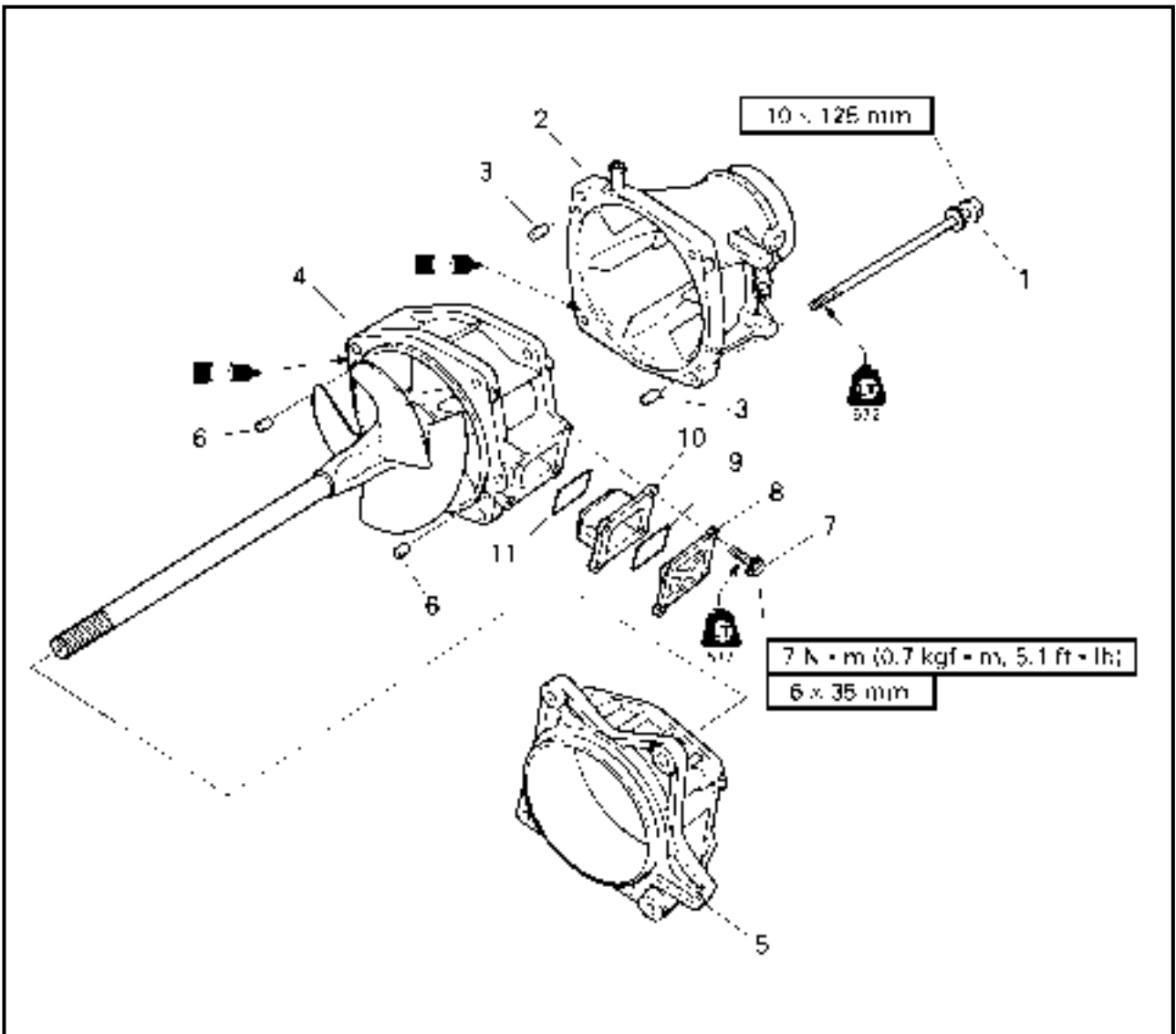

Step	Procedure/Part name	Q'ty	Service points
7	Bolt	4	Reverse the removal steps for installation.
8	Water inlet cover	1	
9	Packing	1	
10	Water inlet strainer	1	
11	Packing	1	

**IMPELLER DUCT AND DRIVE SHAFT
EXPLODED DIAGRAM**

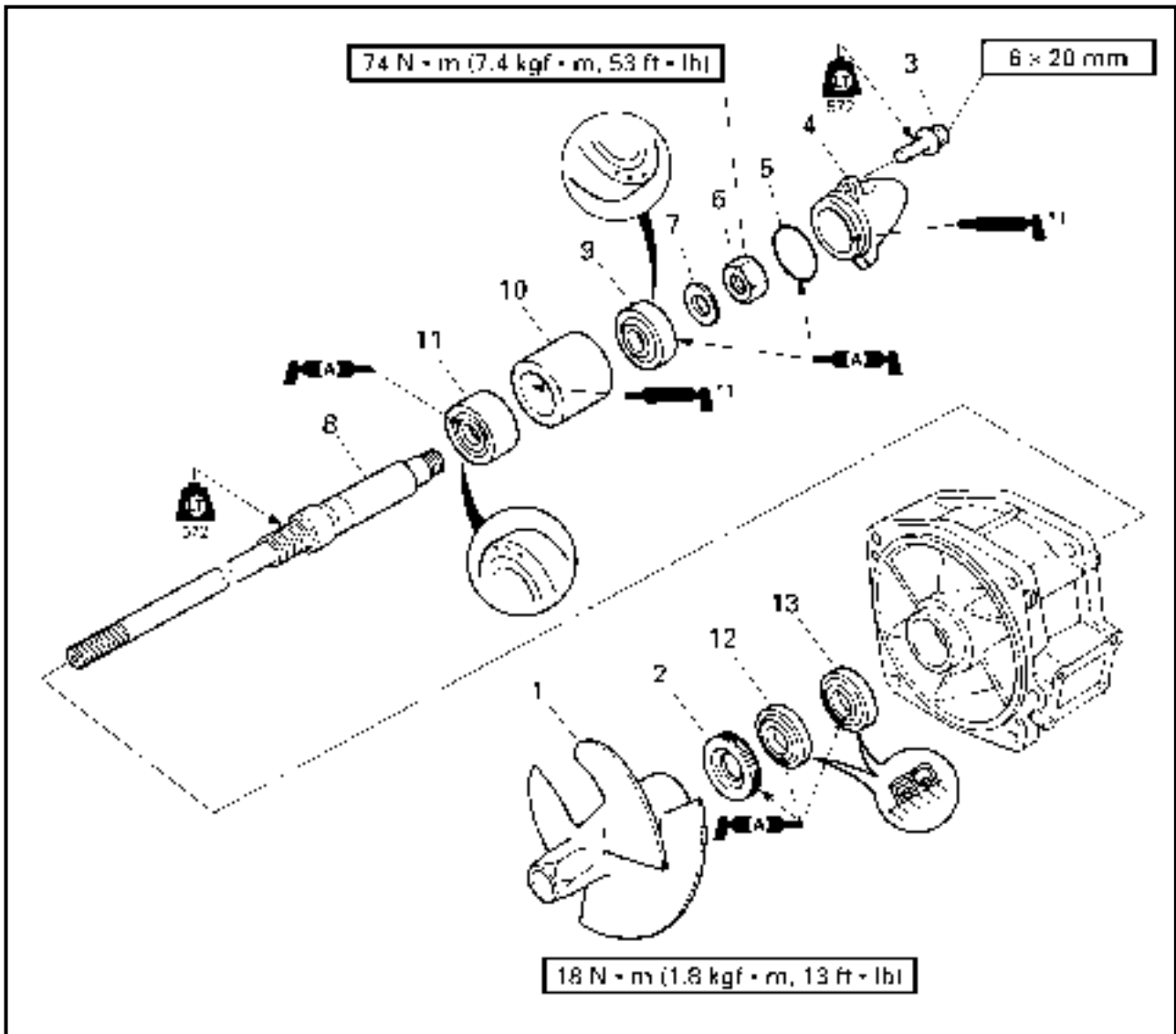

REMOVAL AND INSTALLATION CHART

Step	Procedure/Part name	Q'ty	Service points
	IMPELLER DUCT AND DRIVE SHAFT DISASSEMBLY		Follow the left "Step" for disassembly.
1	Impeller	1	Left-hand threads
2	Spacer	1	
3	Bolt	3	
4	Cap	1	
5	O-ring	1	
6	Nut	1	
7	Washer	1	

*1: EPNOC grease AP #0

EXPLODED DIAGRAM

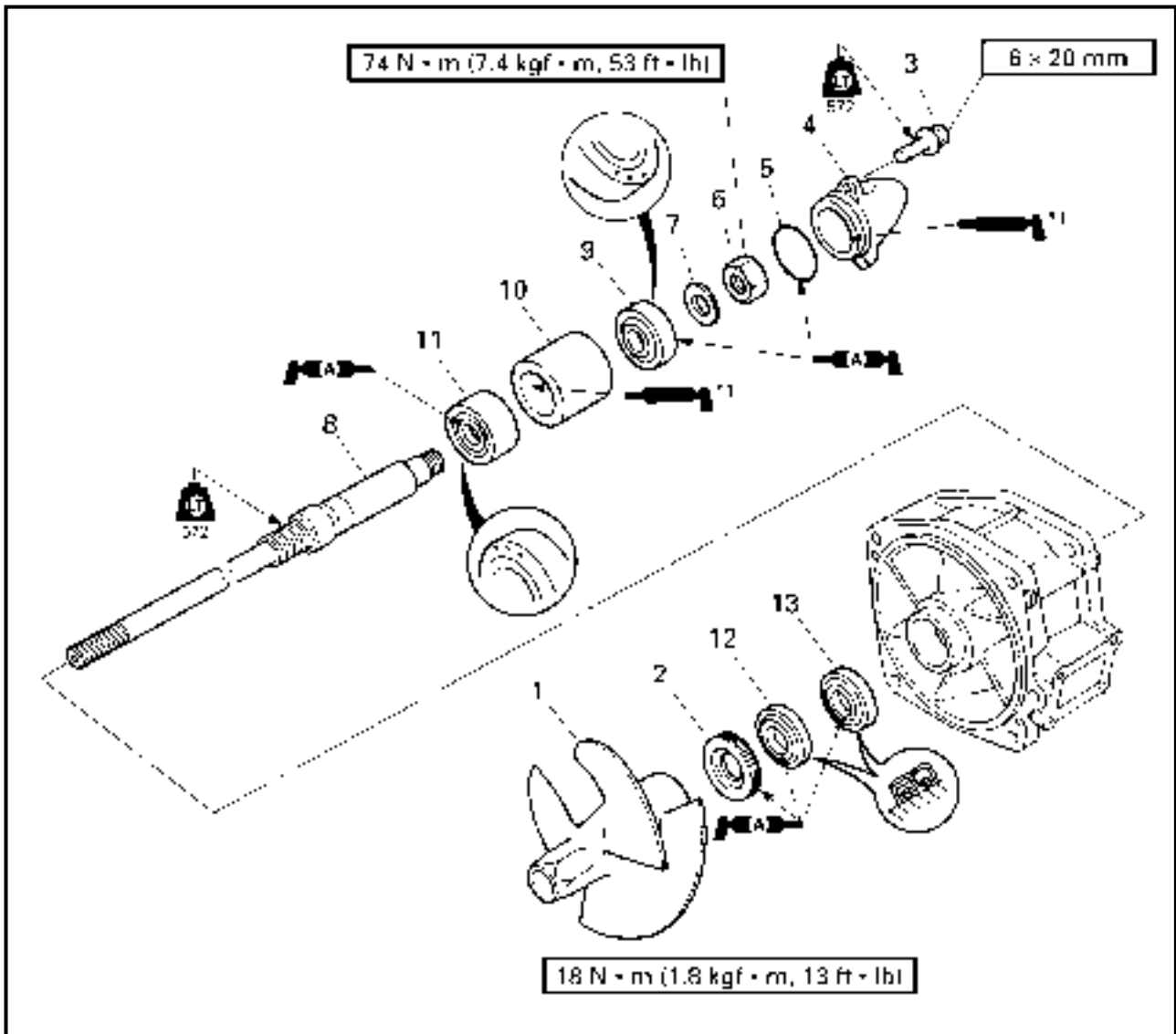

Step	Procedure/Part name	Q'ty	Service points
8	Drive shaft	1	
9	Rear bearing	1	Not reusable
10	Spacer	1	
11	Front bearing	1	Not reusable
12	Oil seal	1	Not reusable
13	Oil seal	1	Not reusable
			Reverse the disassembly steps for assembly.

*1: EPNOC grease AP #0

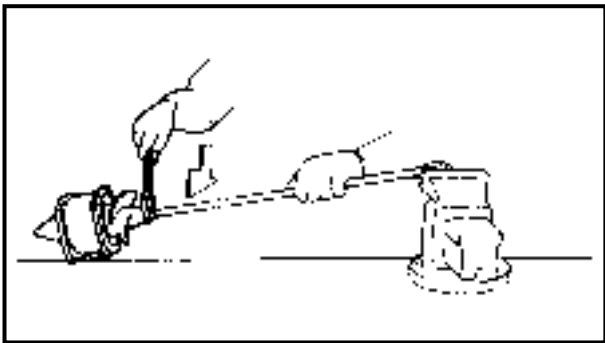

SERVICE POINTS

Drive shaft removal

1. Remove:
 - Impeller



Drive shaft holder:
YB-06151/90890-06519

NOTE:

The impeller has left-hand threads. Turn the impeller clockwise to loosen it.

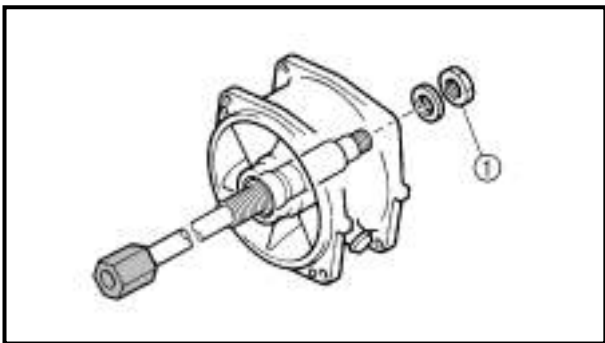

2. Remove:
 - Nut ①



Drive shaft holder:
YB-06151/90890-06519

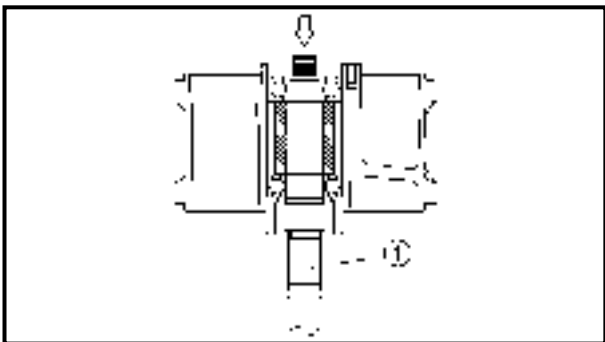

3. Remove:
 - Drive shaft ①

NOTE:

Remove the drive shaft with a press.

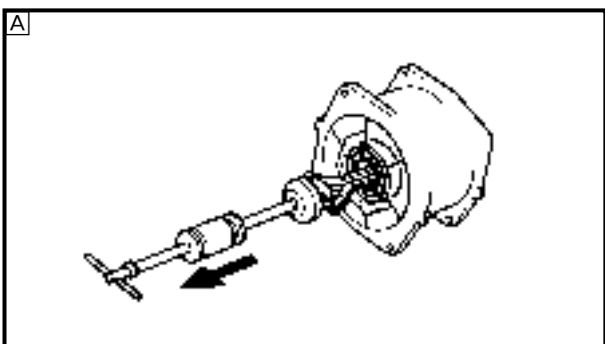

4. Remove:
 - Rear bearing



Slide hammer set:
YB-06096
Stopper guide plate:
90890-06501
Bearing puller:
90890-06535
Bearing puller claw 1:
90890-06536
Stopper guide stand:
90890-06538

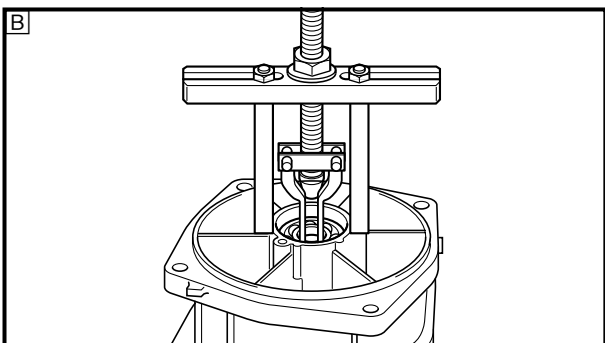

- A** For USA and Canada
- B** For worldwide

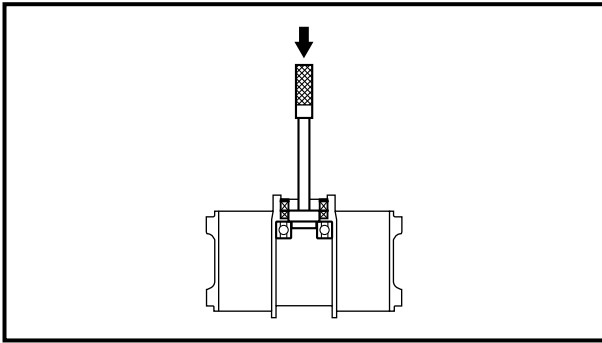

5. Remove:
- Front bearing



Driver rod L3:
YB-06071/90890-06652
Needle bearing attachment:
YB-06112/90890-06614

NOTE: _____

Remove the front bearing with a press.

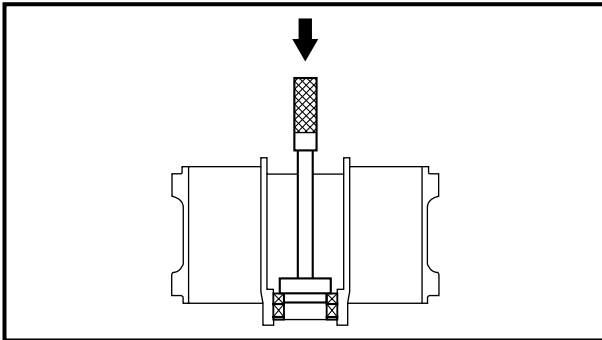

6. Remove:
- Oil seals



Driver rod L3:
YB-06071/90890-06652
Needle bearing attachment:
YB-06196/90890-06653

NOTE: _____

Remove the oil seals with press.

Impeller inspection

Refer to "JET PUMP UNIT" in chapter 3.

Drive shaft inspection

1. Inspect:
- Drive shaft
 Damage/wear → Replace.

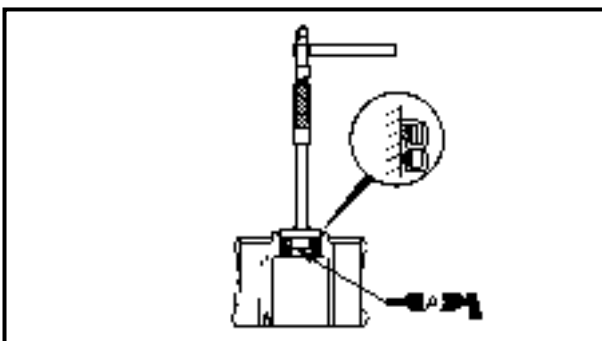

Drive shaft installation

1. Install:
- Oil seals



Driver rod:
YB-06071/90890-06606
Ball bearing attachment:
YB-06156/90890-06634

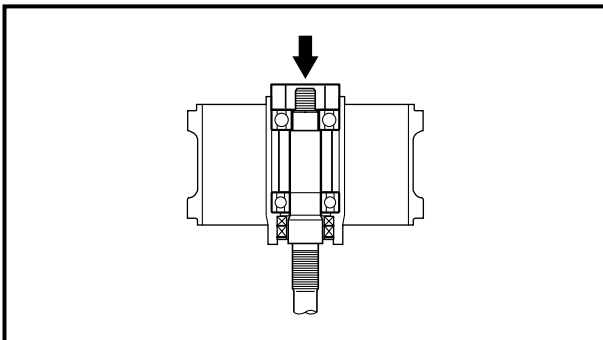
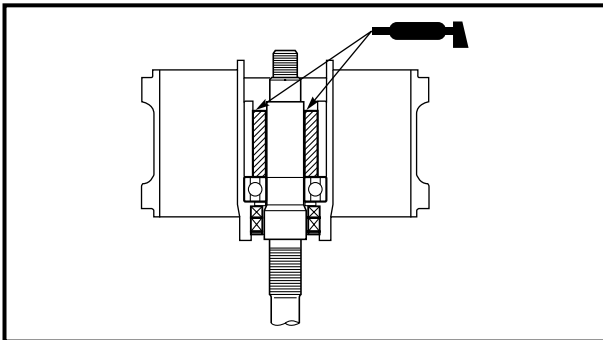
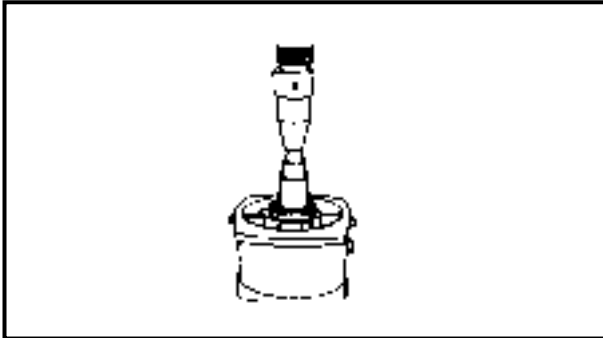
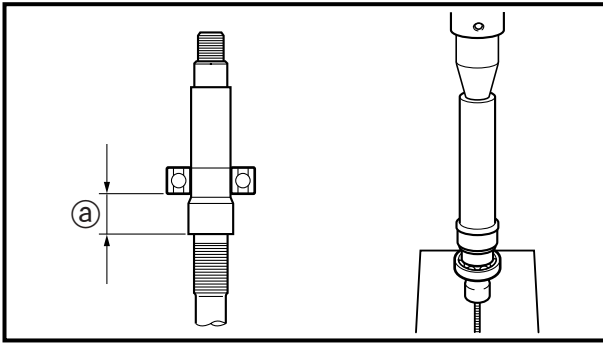

2. Install:
- Front bearing
 - Drive shaft

NOTE: _____
Install the front bearing and drive shaft with a press.



Distance ①:
23 ± 0.1 mm (0.91 ± 0.004 in)

3. Install:
- Drive shaft (with front bearing)
 - Spacer
 - Impeller duct

NOTE: _____
Press the spacer and the front bearing with a 36-mm deep socket.

4. Add:
- EPNOC grease AP #0
(between the drive shaft and spacer)



Quantity:
Approximately 1/3 of capacity

5. Install:
- Rear bearing



Bearing inner/outer race attachment:
YB-34474

NOTE: _____

- Press the bearing inner/outer race at the same time holding the drive shaft and impeller duct.
- If a bearing inner/outer race attachment is not available, use a washer or pipe with an outer diameter of 46 mm (1.81 in) and an inner diameter of 20 mm (0.79 in).

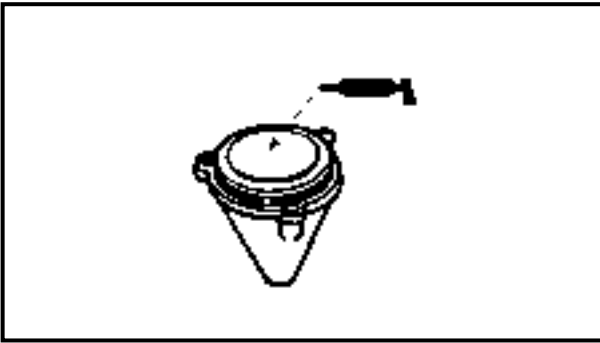

6. Add:
- EPNOC grease AP #0 (into the cap)

	Quantity: Approximately 1/3 of capacity
--	---

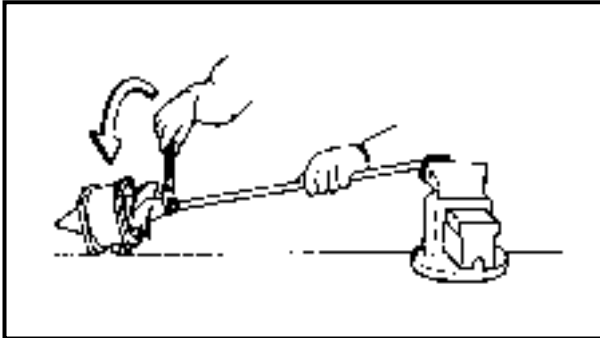

7. Install:
- Nut
 - Impeller

	Drive shaft holder: YB-06151/90890-06519
--	--

**TRANSOM PLATE AND HOSES
EXPLODED DIAGRAM**

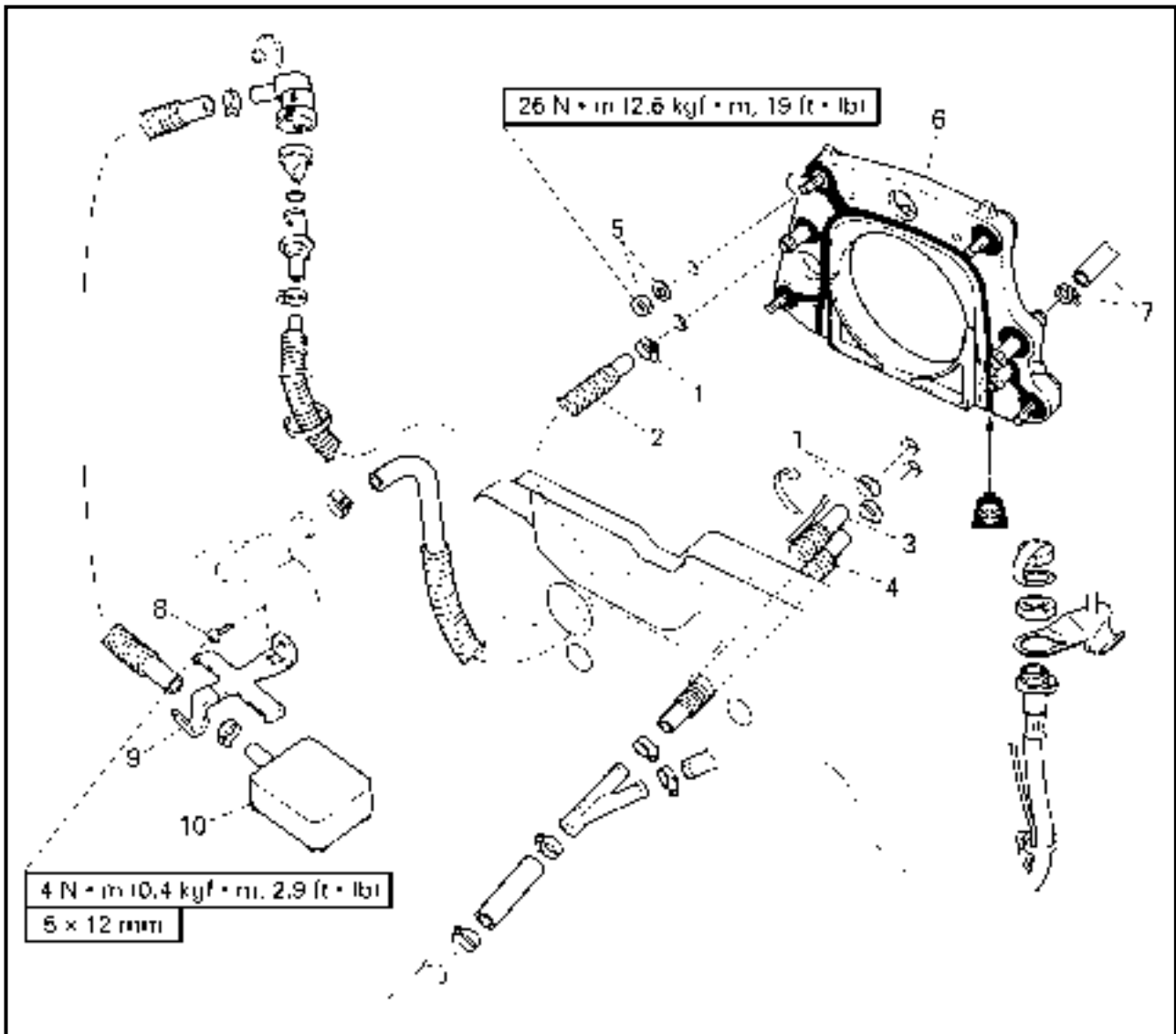

REMOVAL AND INSTALLATION CHART

Step	Procedure/Part name	Q'ty	Service points
	TRANSOM PLATE AND HOSES REMOVAL		Follow the left "Step" for removal.
	Exhaust system		Refer to "EXHAUST SYSTEM" in chapter 8.
	Jet pump unit		Refer to "JET PUMP UNIT".
1	Hose clamp	3	
2	Cooling water hose	1	Cooling water outlet
3	Bilge hose 1	1	NOTE: _____ Route the bilge hose 1 under the drive shaft tube.

EXPLODED DIAGRAM

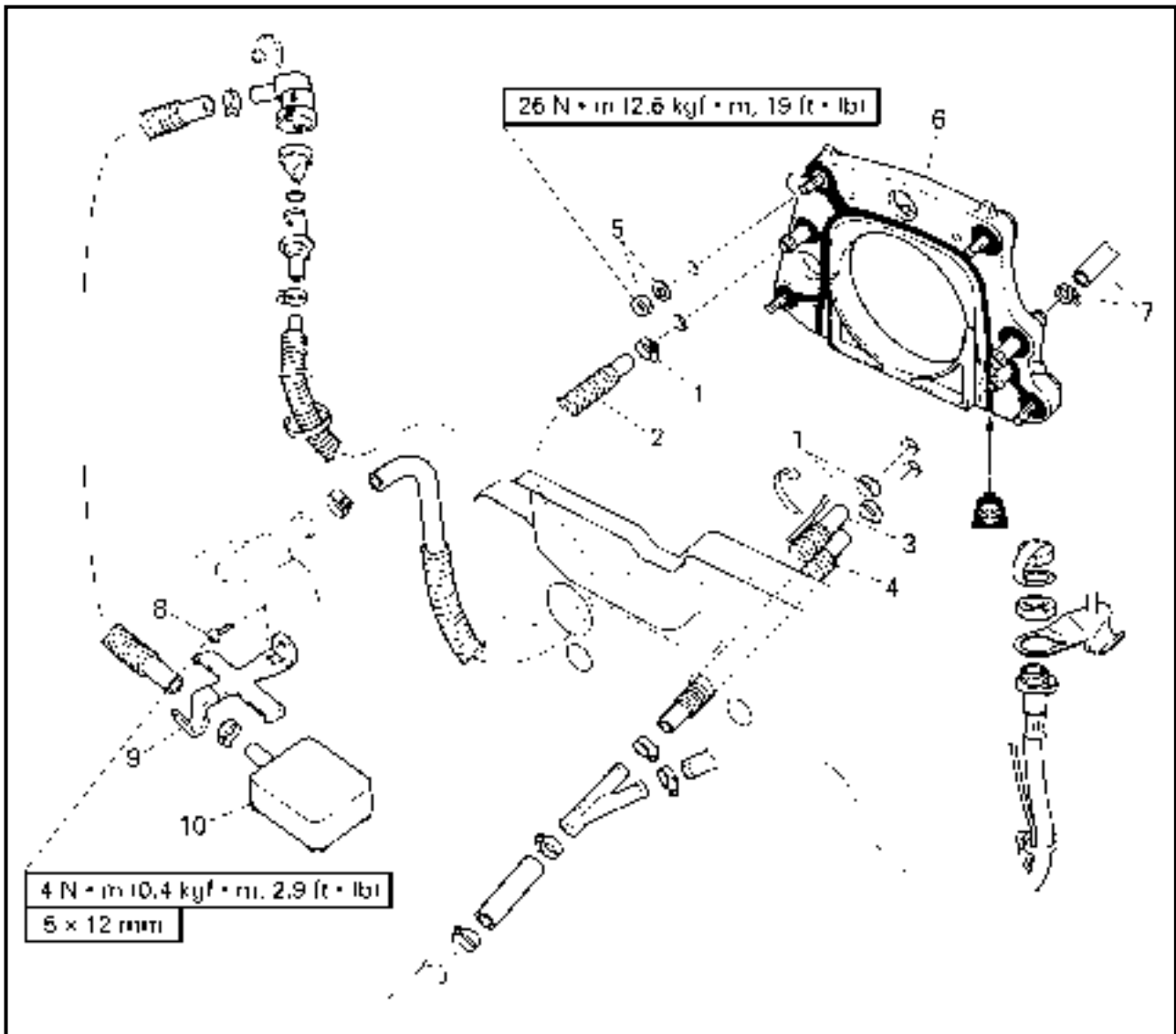

Step	Procedure/Part name	Q'ty	Service points
4	Cooling water hose	1	Cooling water inlet
5	Nut/washer	4/4	
6	Transom plate	1	
7	Clamp/bilge hose 2	1/1	
8	Screw	1	
9	Bilge strainer holder	1	
10	Bilge strainer	1	
			Reverse the removal steps for installation.

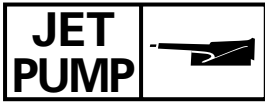

SERVICE POINTS

Bilge strainer inspection

Refer to "JET PUMP UNIT" in chapter 3.

Bilge hose inspection

1. Inspect:

- Bilge hoses

Cracks/damage/wear → Replace.

**BEARING HOUSING
EXPLODED DIAGRAM**

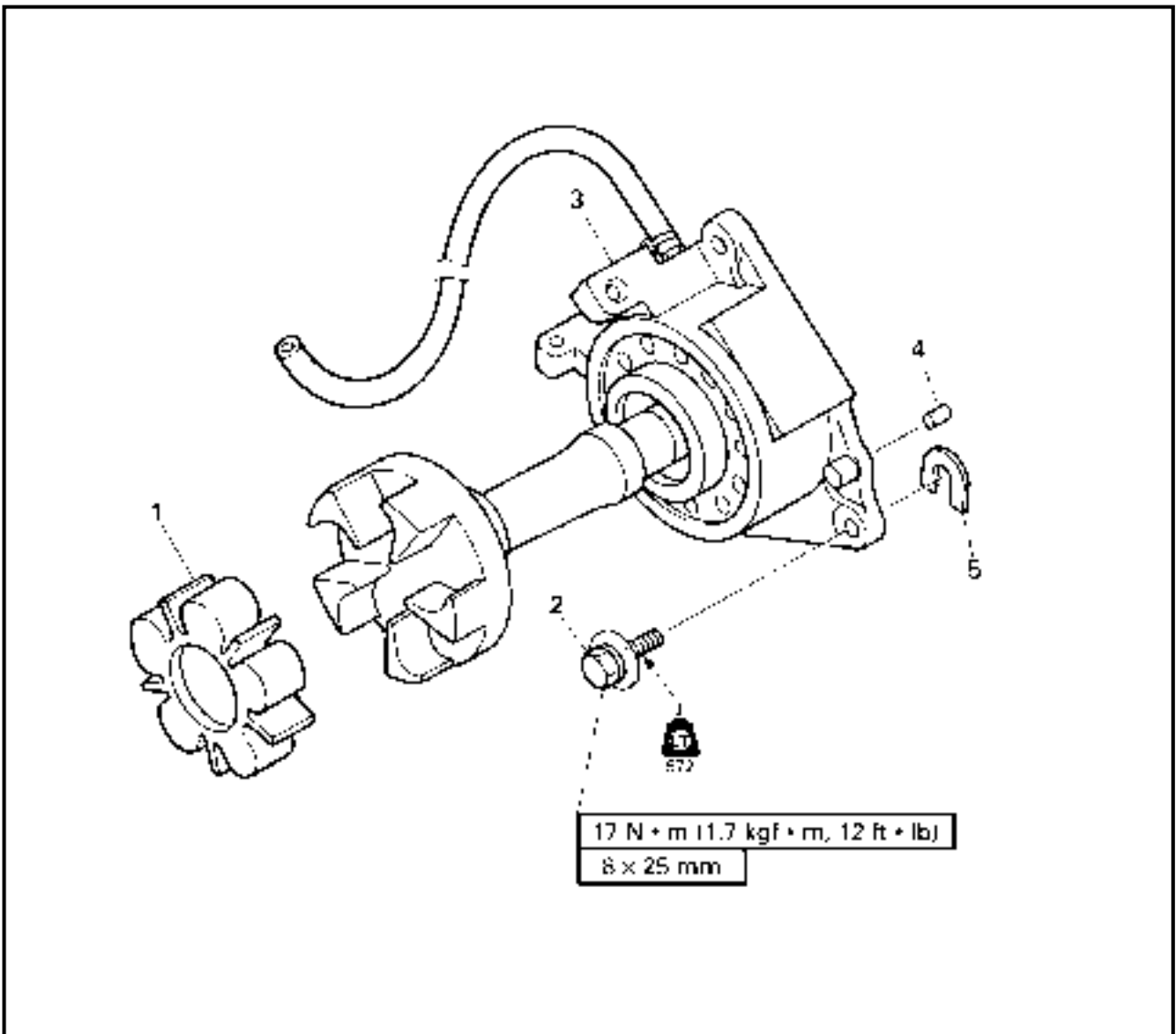

REMOVAL AND INSTALLATION CHART

Step	Procedure/Part name	Q'ty	Service points
	BEARING HOUSING REMOVAL		
	Engine unit		Follow the left "Step" for removal. Refer to "ENGINE UNIT" in chapter 5.
1	Rubber coupling	1	
2	Bolt	3	
3	Intermediate housing assembly	1	
4	Pin	2	
5	Shim	*	NOTE: _____ Install the shims in their original locations. _____ Reverse the removal steps for installation.

*: As required

EXPLODED DIAGRAM

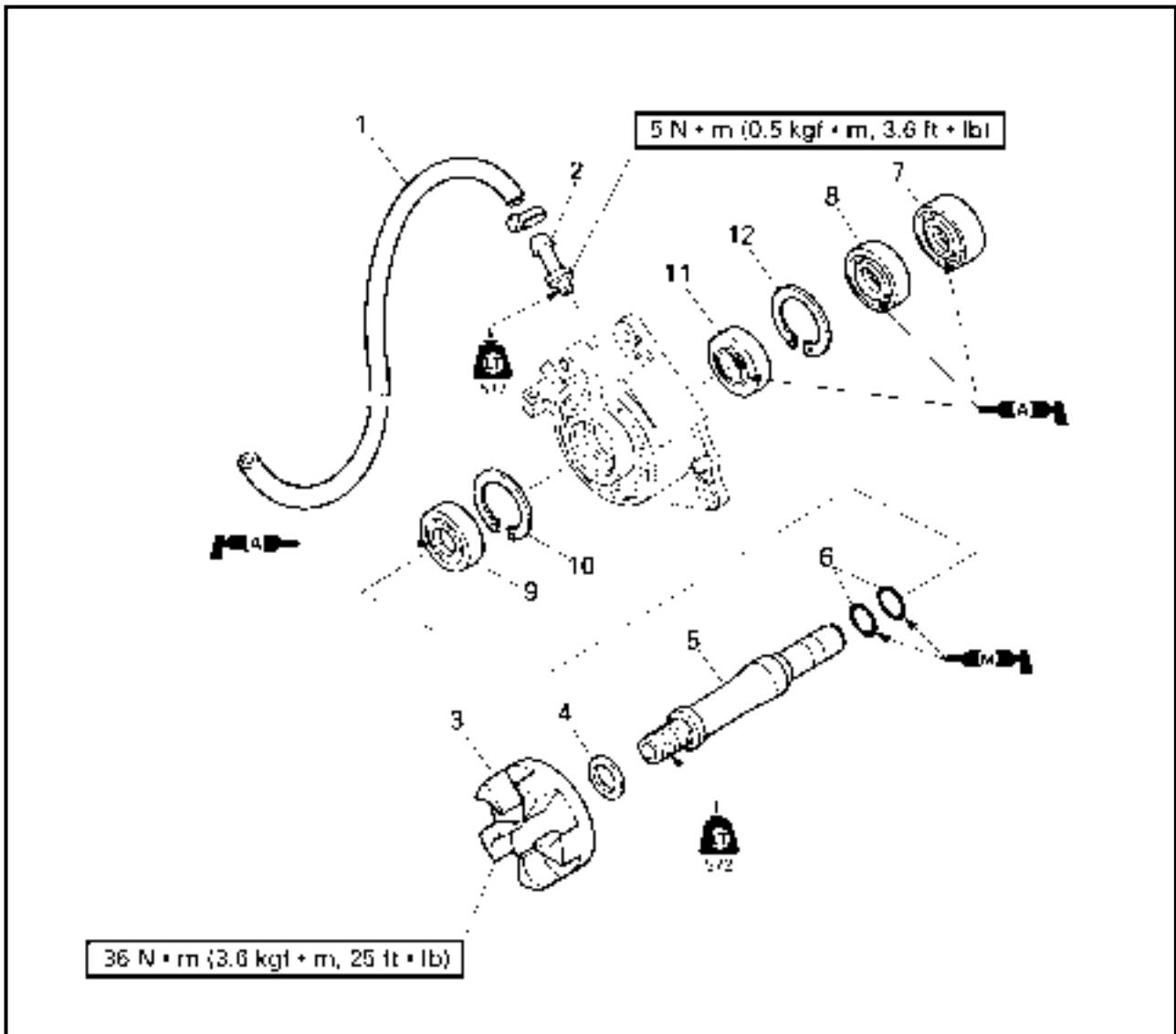

REMOVAL AND INSTALLATION CHART

Step	Procedure/Part name	Q'ty	Service points
	BEARING HOUSING DISASSEMBLY		Follow the left "Step" for disassembly.
1	Grease hose	1	
2	Nipple	1	
3	Driven coupling	1	
4	Washer	1	
5	Intermediate drive shaft	1	
6	O-ring	2	
7	Oil seal	1	Not reusable

EXPLODED DIAGRAM

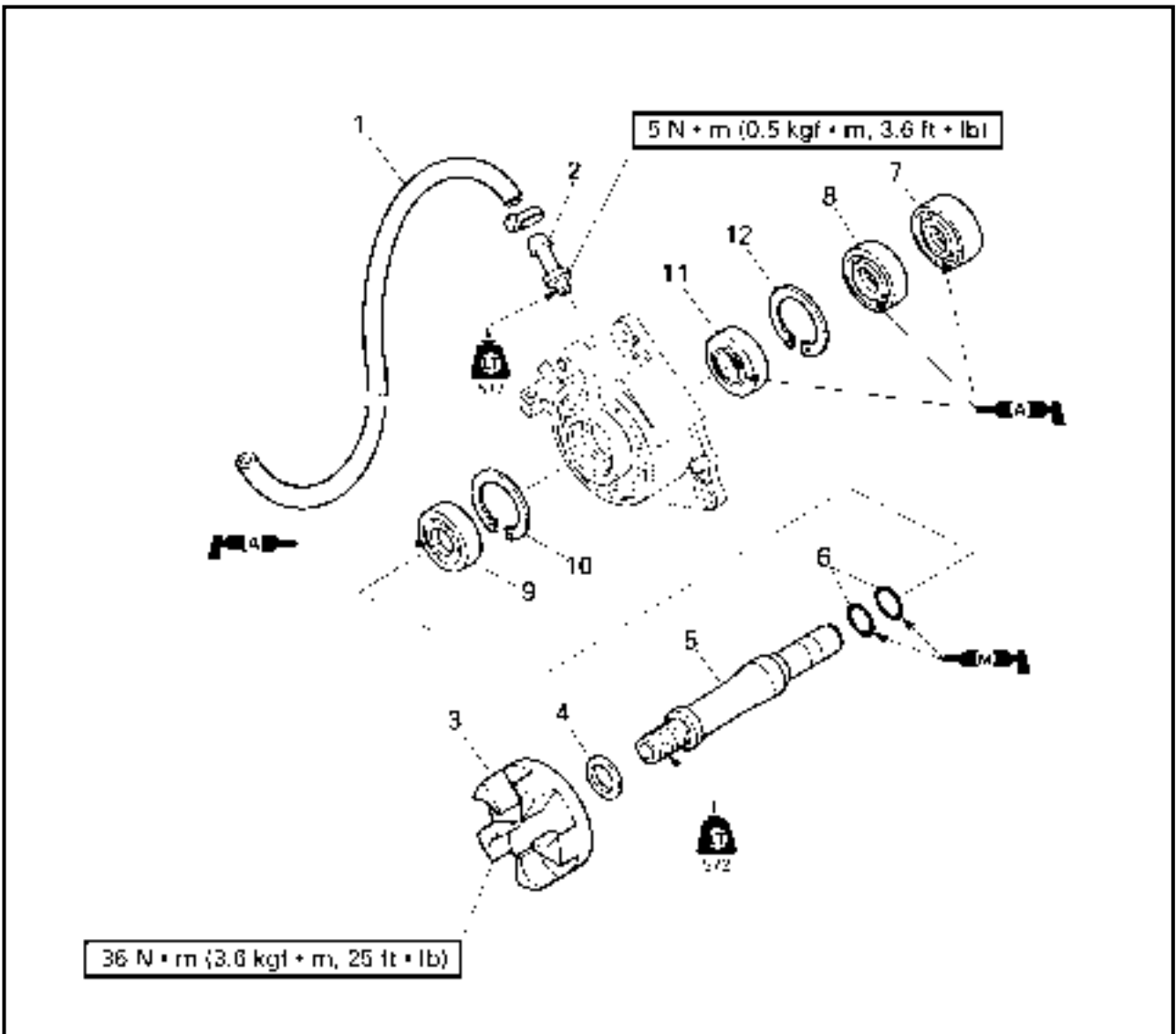

Step	Procedure/Part name	Q'ty	Service points
8	Oil seal	1	Not reusable
9	Oil seal	1	Not reusable
10	Circlip	1	
11	Bearing	1	Not reusable
12	Circlip	1	
			Reverse the disassembly steps for assembly.

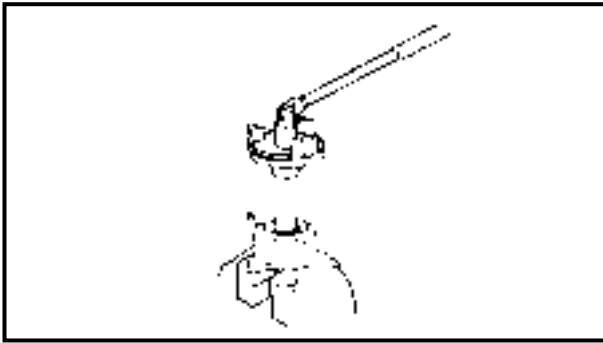

SERVICE POINTS

Driven coupling removal and installation

1. Remove and install:
 - Driven coupling



Coupler wrench:
YW-06551/90890-06551
Shaft holder:
YB-06552/90890-06552

NOTE: _____

Install the driven coupling with the same special tools that were used for removal.

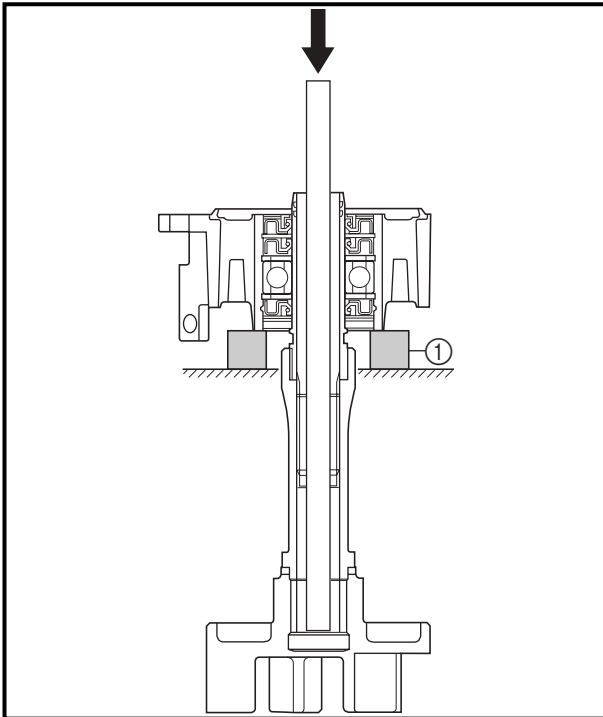

Intermediate drive shaft removal

1. Remove:
 - Intermediate drive shaft

Removal steps:

- Temporarily install the driven coupling to the intermediate drive shaft.
- Insert the long rod to the driven coupling shaft.
- Press out the intermediate drive shaft by pushing the rod.

NOTE: _____

Support the intermediate housing with steel blocks ① and press the driven coupling shaft.

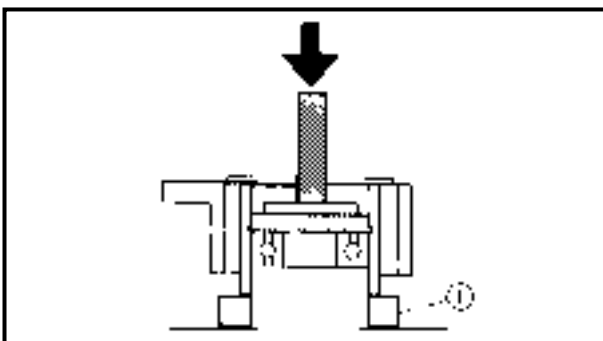

Bearing removal

1. Remove:
 - Bearing



Driver rod:
YB-06071/90890-06606
Bearing outer race attachment:
YB-06016/90890-06626

NOTE: _____

- Install the bearing with the same special tools that were used for removal.
- Support the intermediate housing with steel blocks ① and press the bearing.

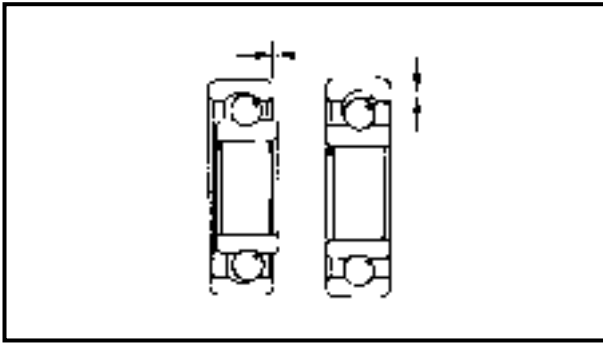

Bearing, driven coupling shaft, and grease hose inspection

1. Inspect:
 - Bearing
Rotate the inner race by hand.
Damage/rough movement → Replace.
 - Intermediate drive shaft
Damage/pitting → Replace.
 - Grease hose
Cracks/wear → Replace.

Driven coupling inspection

1. Inspect:
 - Driven coupling
 - Driven coupling damper
Damage/wear → Replace.

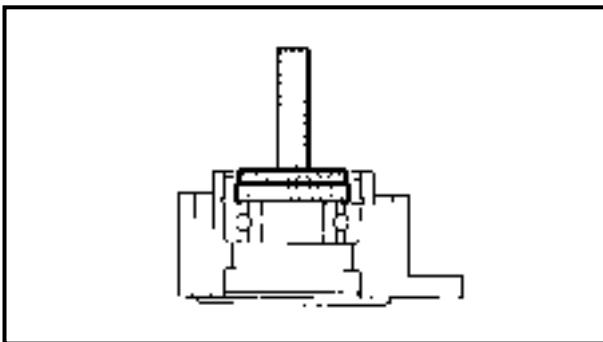

Bearing installation

1. Install:
 - Circlip (rear)
2. Install:
 - Bearing



Driver rod:
YB-06071/90890-06606
Bearing outer race attachment:
YB-06016/90890-06626

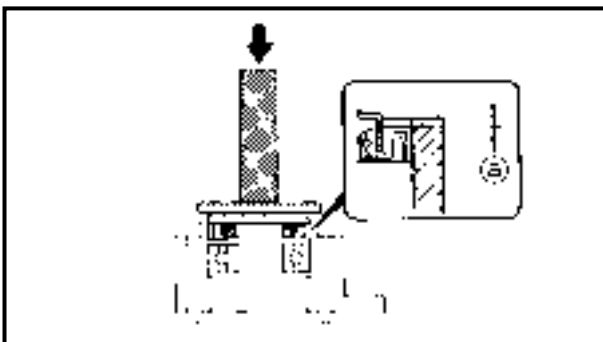

Oil seal installation

1. Install:
 - Oil seal



Driver rod:
YB-06071/90890-06606
Bearing outer race attachment:
YB-06016/90890-06626

NOTE: _____

Before installing the oil seal, lubricate the clip glove with water resistant grease.



Distance [Ⓐ]:
6.8–7.2 mm (0.27–0.28 in)

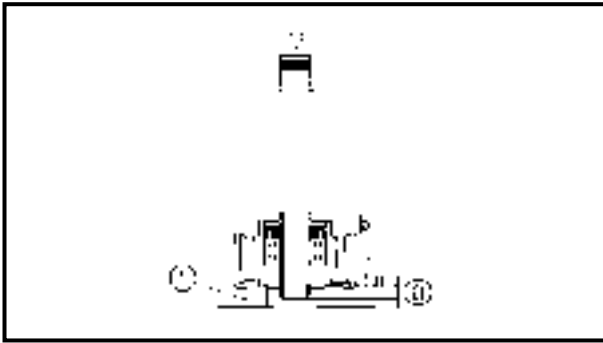

2. Install:
- Intermediate drive shaft



Distance ①:
9.5–10.5 mm (0.37–0.41 in)

NOTE:

Support the intermediate housing with steel blocks ① and press the driven coupling shaft.

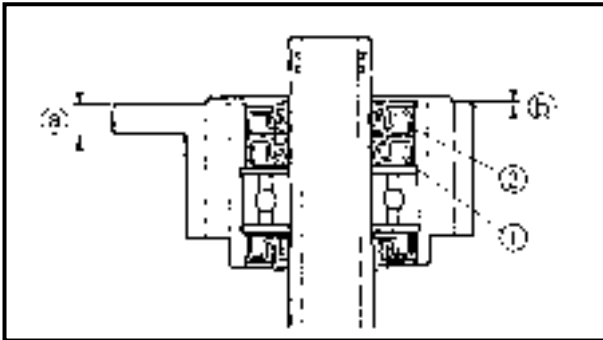

3. Install:
- Oil seal ① [8 mm (0.31 in)]
 - Oil seal ② [10 mm (0.39 in)]



Distance ①:
10.3–10.7 mm (0.41–0.42 in)
Distance ②:
1.6–2.0 mm (0.06–0.08 in)

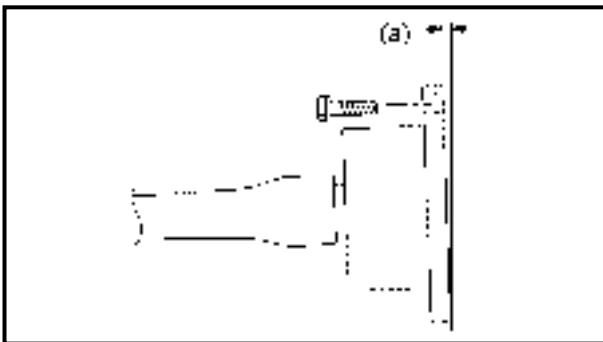

Intermediate housing installation

1. Install:
- Intermediate housing
 - Shim

Installation steps:

- Install the intermediate housing.
- Measure the clearance ① at each bolt hole.
- Install the suitable shim from the table below.

Clearance ①	Shim thickness
0–0.2 mm (0–0.008 in)	No need
0.3–0.7 mm (0.012–0.028 in)	0.5 mm
0.8–1.2 mm (0.031–0.047 in)	1.0 mm
1.3–2.0 mm (0.051–0.079 in)	1.5 mm

NOTE:

Install the shim(s) to the original position if the intermediate housing is not replaced.

CHAPTER 7 ELECTRICAL SYSTEM

ELECTRICAL COMPONENTS	7-1
ELECTRICAL BOX	7-2
EXPLODED DIAGRAM.....	7-2
REMOVAL AND INSTALLATION CHART	7-2
ELECTRICAL ANALYSIS	7-6
INSPECTION.....	7-6
Digital tester	7-6
Low resistance measurement.....	7-6
Peak voltage measurement.....	7-7
Peak voltage adaptor	7-7
Test harness	7-8
IGNITION SYSTEM	7-9
WIRING DIAGRAM.....	7-9
IGNITION SPARK GAP.....	7-10
IGNITION SYSTEM PEAK VOLTAGE.....	7-11
SPARK PLUGS	7-12
SPARK PLUG CAPS	7-12
IGNITION COIL	7-12
ENGINE STOP SWITCH.....	7-13
THERMOSWITCH.....	7-13
STARTING SYSTEM	7-14
WIRING DIAGRAM.....	7-14
BATTERY	7-15
WIRING CONNECTIONS	7-15
FUSE	7-15
STARTER SWITCH.....	7-15
STARTER RELAY.....	7-16
STARTER MOTOR	7-17
EXPLODED DIAGRAM.....	7-17
REMOVAL AND INSTALLATION CHART	7-17
SERVICE POINTS	7-20
Armature inspection	7-20
Brush holder inspection	7-21
Starter motor front cover inspection.....	7-21

CHARGING SYSTEM..... 7-22
WIRING DIAGRAM..... 7-22
FUUSE 7-23
BATTERY 7-23
RECTIFIER/REGULATOR PEAK VOLTAGE 7-23
LIGHTING COIL PEAK VOLTAGE..... 7-23

YPVS 7-24
WIRING DIAGRAM..... 7-24
FUUSE 7-25
BATTERY 7-25
PICKUP COIL 7-25
CDI UNIT 7-25

YPVS SERVOMOTOR 7-26
EXPLODED DIAGRAM..... 7-26
REMOVAL AND INSTALLATION CHART 7-26
SERVICE POINTS 7-27
 YPVS cable removal and installation 7-27
 YPVS cable inspection 7-27
 YPVS servomotor inspection 7-27
 YPVS cable adjustment 7-28

INDICATION SYSTEM..... 7-29
WIRING DIAGRAM..... 7-29
FUUSE 7-30
BATTERY 7-30
LIGHTING COIL 7-30
RECTIFIER/REGULATOR..... 7-30
CDI UNIT 7-30
THERMOSWITCH..... 7-30
BUZZER 7-30
OIL LEVEL SENSOR 7-30
FUEL LEVEL SENSOR..... 7-31
MULTIFUNCTION METER 7-31
 Multifunction meter 7-31
MULTIFUNCTION METER REMOVAL 7-31
 Display function 7-32
 Fuel level gauge 7-33
 Oil level gauge..... 7-34
 Overheat warning indicator 7-35
 Speed meter 7-36
 Speed sensor..... 7-36

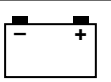

ELECTRICAL COMPONENTS

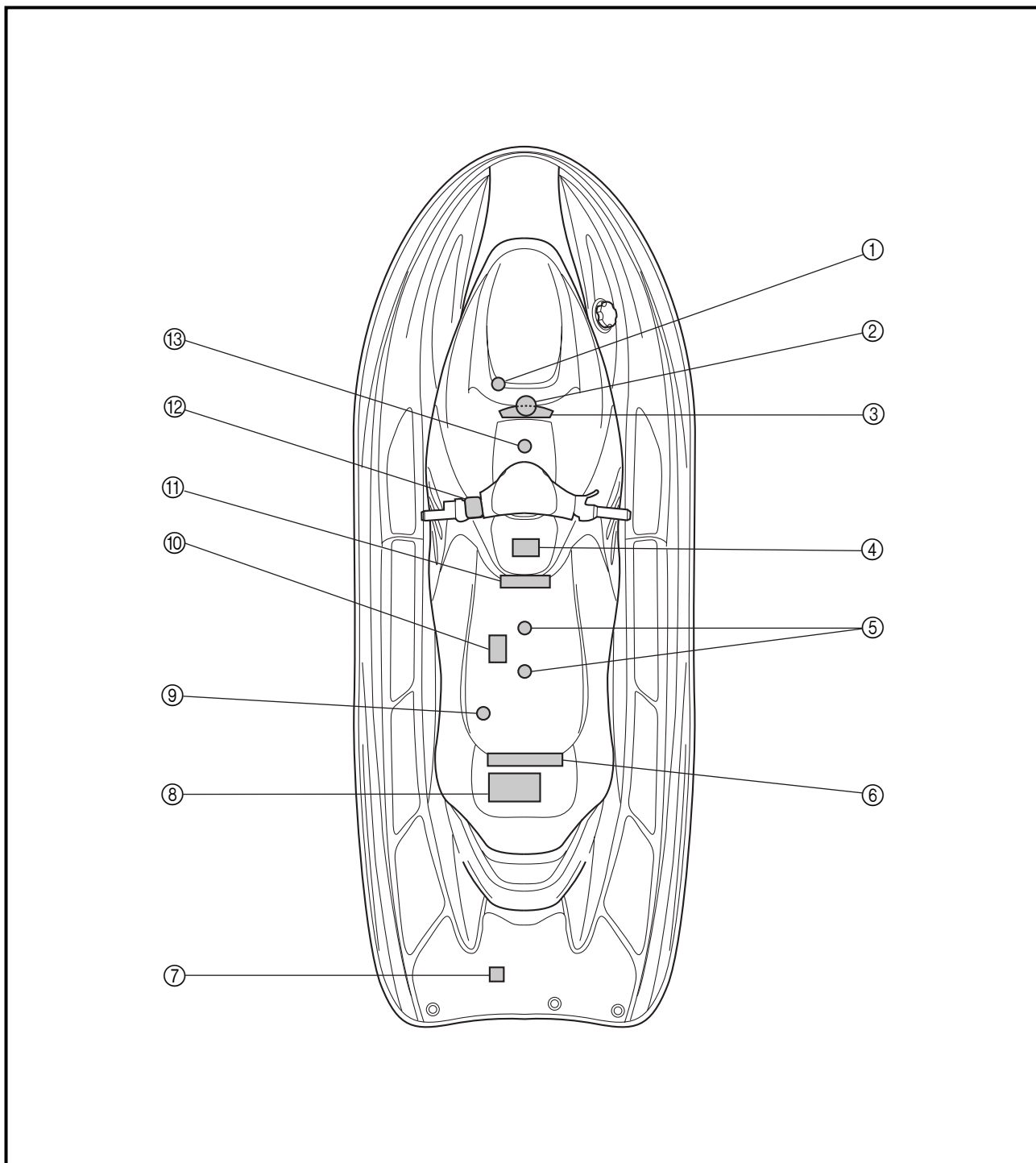

- | | |
|-----------------------|---|
| ① Buzzer | ⑨ Thermoswitch |
| ② Fuel level sensor | ⑩ Starter motor |
| ③ Multifunction meter | ⑪ Stator coil and pickup coil |
| ④ YPVS servomotor | ⑫ Engine stop switch, engine stop lanyard switch and starter switch |
| ⑤ Spark plugs | ⑬ Oil level sensor |
| ⑥ Electrical box | |
| ⑦ Speed sensor | |
| ⑧ Battery | |

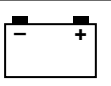

**ELECTRICAL BOX
EXPLODED DIAGRAM**

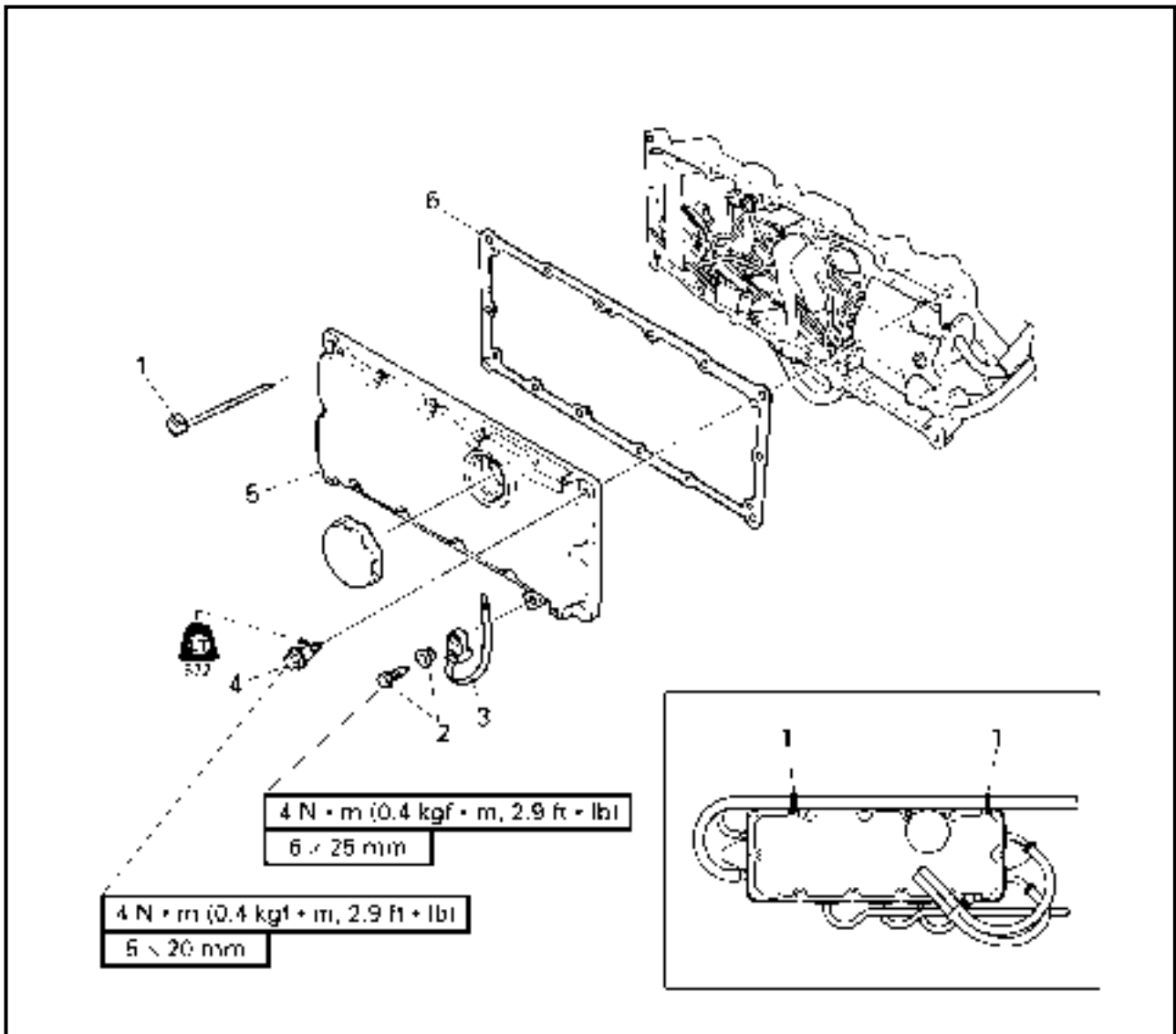

REMOVAL AND INSTALLATION CHART

Step	Procedure/Part name	Q'ty	Service points
	ELECTRICAL BOX DISASSEMBLY		
	Electrical box		Follow the left "Step" for disassembly. Refer to "BATTERY BOX" in chapter 8.
1	Plastic locking tie	2	Not reusable
2	Bolt/collar	1/1	NOTE: _____
3	Plastic clamp	1	To separate the battery box from the engine unit, refer to "ENGINE UNIT", "STARTER MOTOR" and "FLYWHEEL MAGNETO" in Chapter 5 to disconnect the leads.
4	Bolt	14	
5	Electrical box cover	1	
6	Gasket	1	

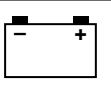

EXPLODED DIAGRAM

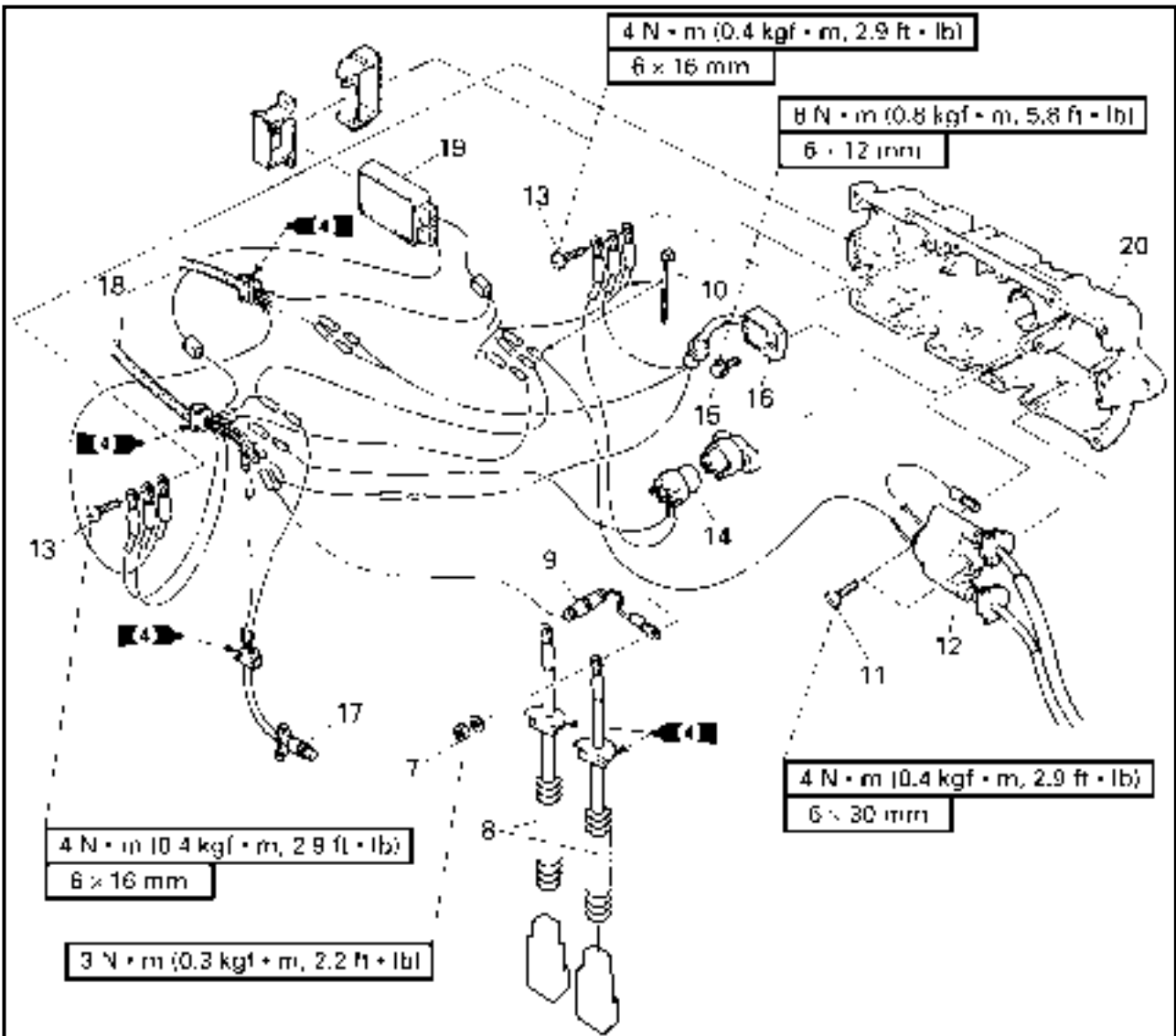

Step	Procedure/Part name	Q'ty	Service points
7	Nut	2	
8	Starter motor lead/ battery positive lead	1/1	
9	Fuse	1	
10	Plastic locking tie	1	Not reusable
11	Screw	2	
12	Ignition coil	1	
13	Screw	2	
14	Starter relay	1	

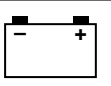

EXPLODED DIAGRAM

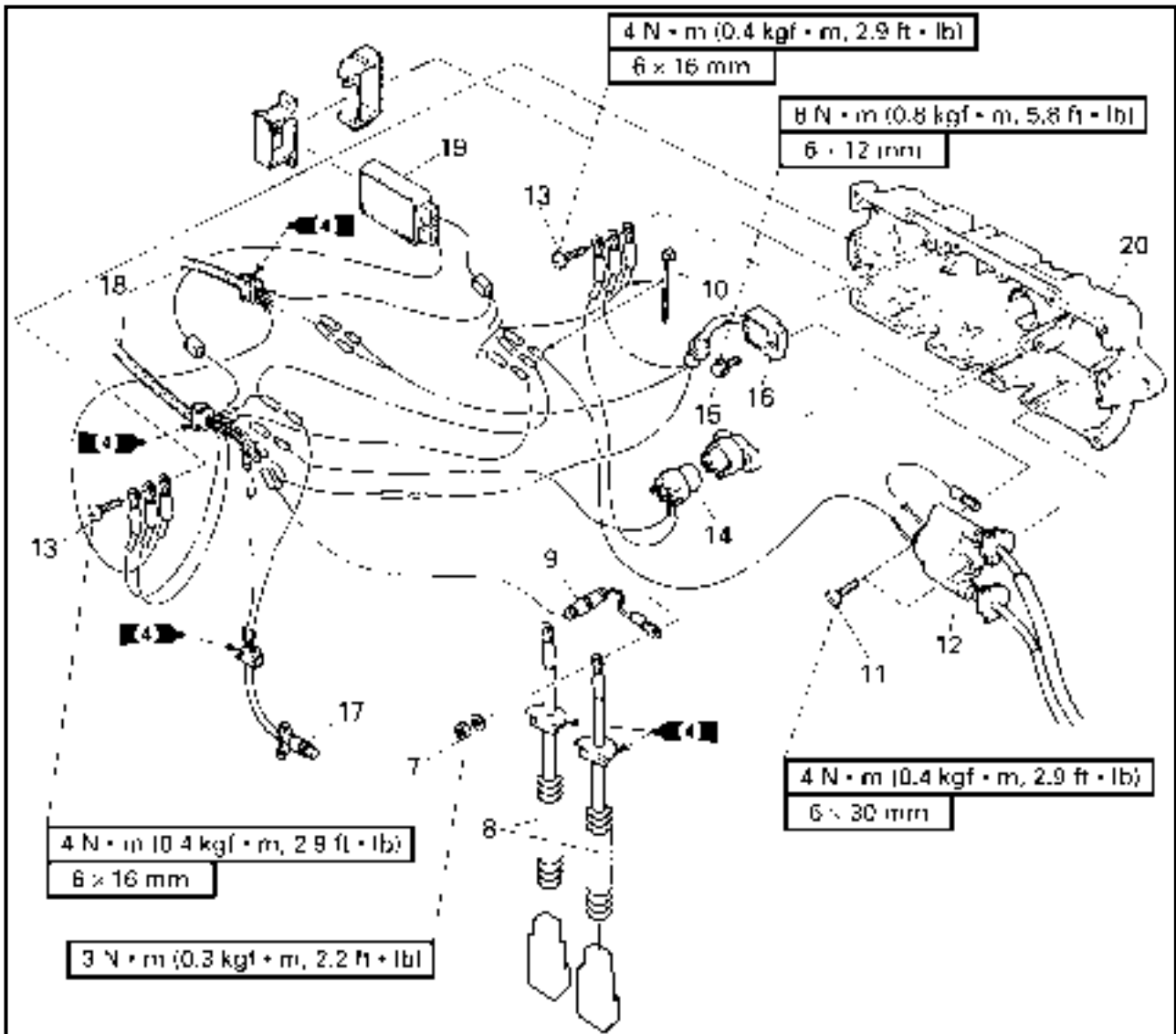

Step	Procedure/Part name	Q'ty	Service points
15	Bolt	1	Reverse the disassembly steps for assembly.
16	Rectifier/regulator	1	
17	Thermoswitch	1	
18	Wire harness	2	
19	CDI unit	1	
20	Electrical box housing	1	

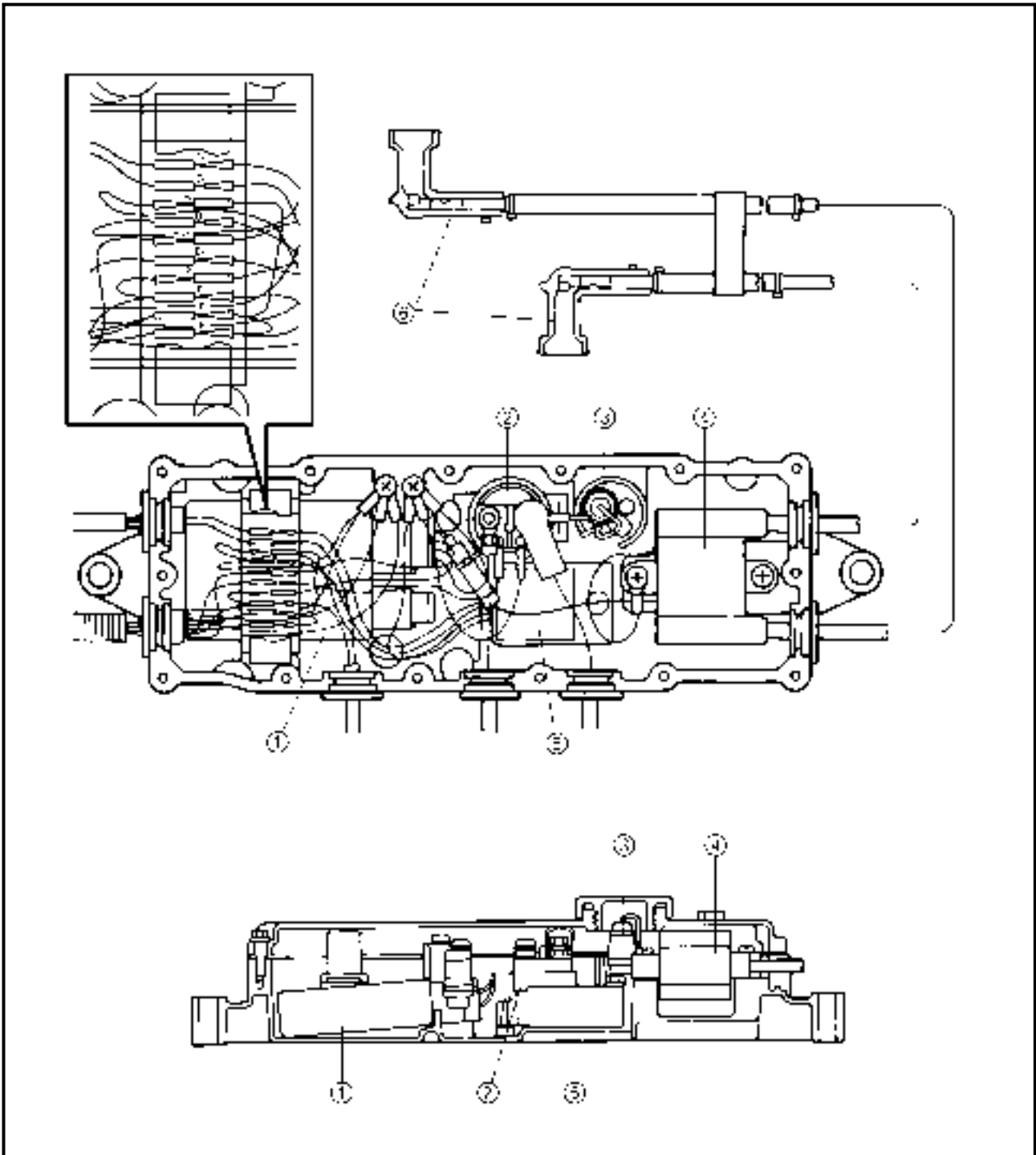
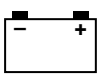

- ① CDI unit
- ② Starter relay
- ③ Fuse (10A)
- ④ Ignition coil
- ⑤ Rectifier/regulator
- ⑥ Spark plug caps

- B : Black
- Br : Brown
- G : Green
- P : Pink
- R : Red
- W : White

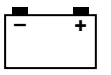

ELECTRICAL ANALYSIS INSPECTION

CAUTION:

- All measuring instruments should be handled with special care. Damaged or mis-handled instruments will not measure properly.
- On an instrument powered by dry batteries, check the battery's voltage periodically and replace the batteries if necessary.

Digital tester

NOTE:

Throughout this chapter the digital tester's part number has been omitted. Refer to the following part number.

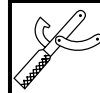
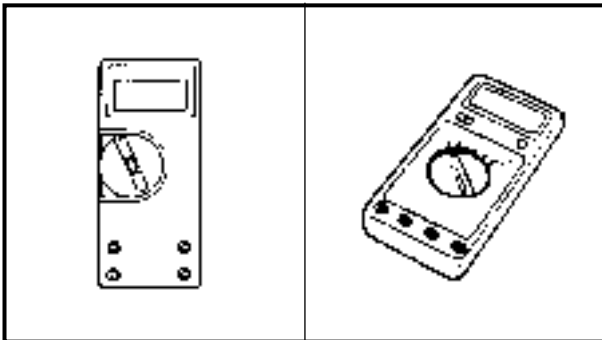

Digital tester:
J-39299/90890-06752

NOTE:

"○—○" indicates a continuity of electricity; i.e., a closed circuit at the respective switch position.

Low resistance measurement

NOTE:

- When measuring a resistance of $10\ \Omega$ or less with the digital tester, the correct measurement cannot be obtained because of the tester's internal resistance.
- To obtain the correct value, subtract the internal resistance from the displayed measurement.
- The internal resistance of the tester can be obtained by connecting both of its terminals.



Correct value =
Displayed measurement –
Internal resistance

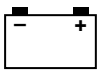

Peak voltage measurement

NOTE:

- When checking the condition of the ignition system it is vital to know the peak voltage.
- Cranking speed is dependant on many factors (e.g., fouled or weak spark plugs, a weak battery). If one of these is defected, the peak voltage will be lower than specification.
- If the peak voltage measurement is not within specification the engine will not operate properly.
- A low peak voltage will also cause components to prematurely wear.

Peak voltage adaptor

NOTE:

- Throughout this chapter the peak voltage adaptor's part number has been omitted. Refer to the following part number.
- The peak voltage adaptor should be used with the digital tester.

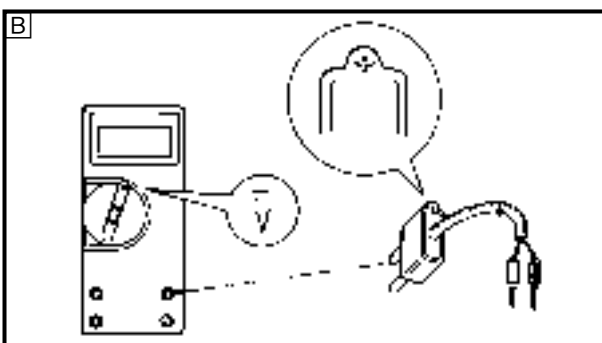
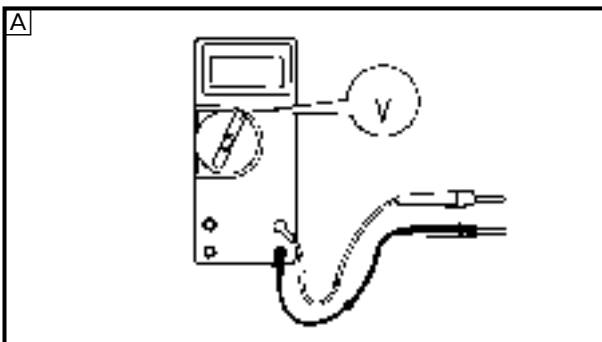
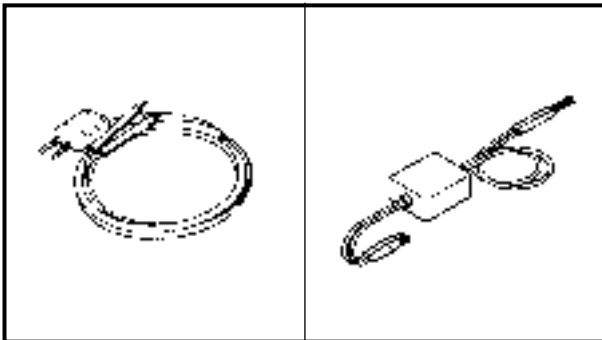

Peak voltage adaptor:
YU-39991/90890-03169

- When measuring the peak voltage, connect the peak voltage adaptor to the digital tester and switch the selector to the DC voltage mode.

NOTE:

- Make sure that the adaptor leads are properly installed in the digital tester.
- Make sure that the positive pin (the "+" mark facing up as shown) on the adaptor is installed into the positive terminal of the tester.
- The test harness is needed for the following tests.

A Voltage measurement

B Peak voltage measurement

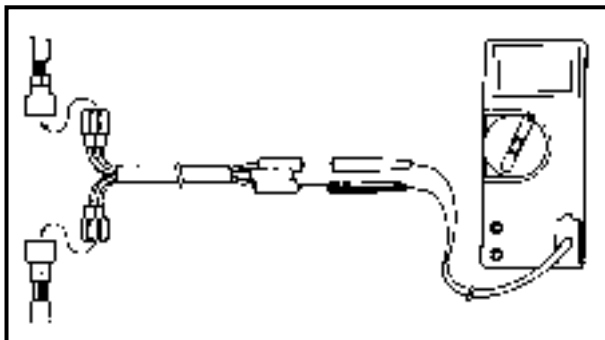
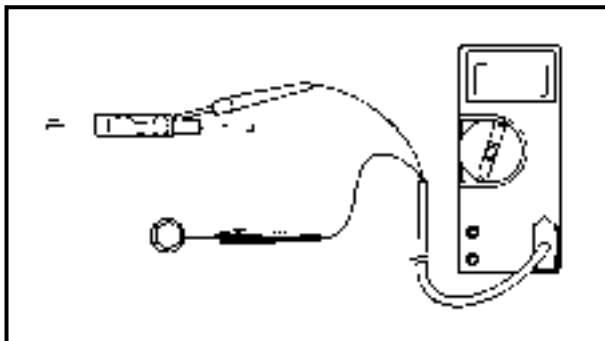
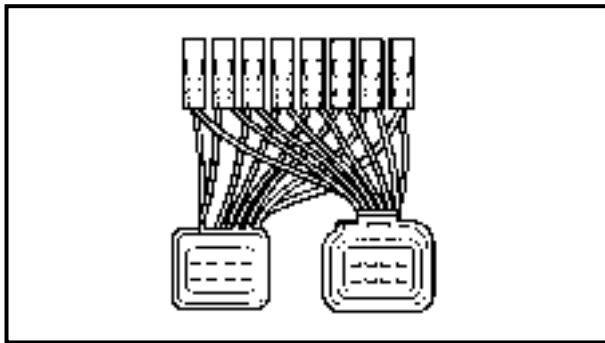
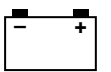
**Test harness**

YW-	90890-	Pin	Usage
06779	06779	8	Charge coil and pickup coil

Checking steps:

- Disconnect the coupler connections.
- Connect the test harness between the couplers.
- Connect the tester terminals to the terminals which are being checked.
- Run the engine and observe the measurement.

NOTE:

- Make sure the output lead (red lead) of the rectifier/regulator is disconnected when measuring the peak voltage of the lighting coil and rectifier/regulator.
- If the charge coil and pickup coil are measured unloaded, disconnect the test harness on the output side coupler.

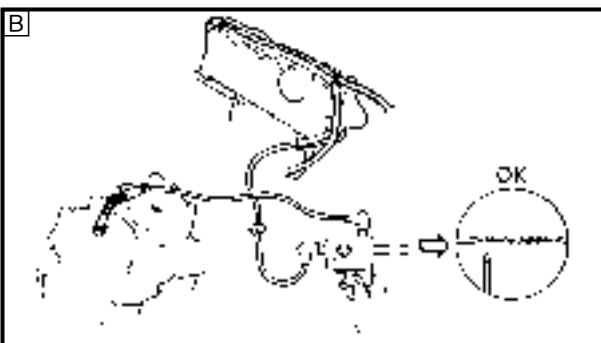
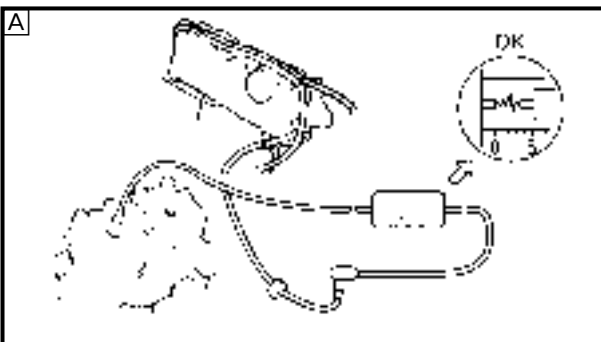
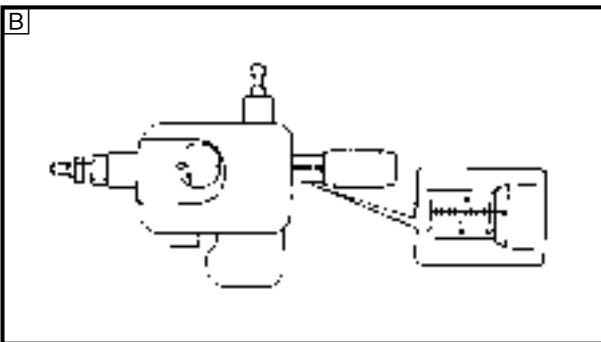
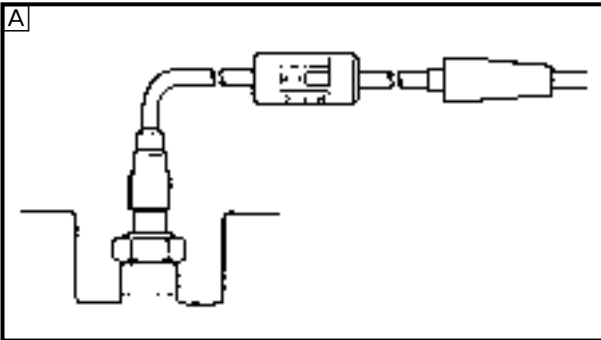
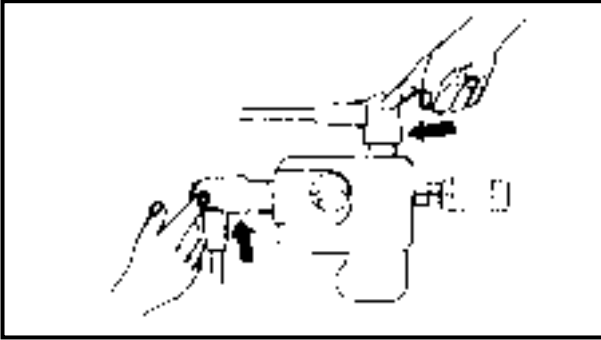
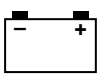

IGNITION SPARK GAP

⚠ WARNING

- When checking the spark gap, do not touch any of the connections of the spark gap tester lead wires.
- When performing the spark gap test, take special care not to let sparks leak out of the removed spark plug cap.
- When performing the spark gap check, keep flammable gas or liquids away, since this test can produce sparks.

1. Check:

- Ignition spark gap
Below specification → Check the CDI unit output peak voltage.
Check the ignition coil for resistance.



Spark gap:
10 mm (0.39 in)

Checking steps:

- Connect the spark plug cap to the spark gap tester.
- Set the spark gap length on the adjusting knob.



Spark gap tester:
YM-34487/90890-06754

- Crank the engine and observe the ignition system spark through the discharge window.

A For USA and Canada

B For worldwide

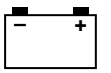

IGNITION SYSTEM PEAK VOLTAGE

⚠ WARNING

When checking the electrical components, do not touch any of the connections of the digital tester lead wires.

NOTE:

- If there is no spark or the spark is weak, continue with the ignition system test.
- If a good spark is obtained, the problem is not with the ignition system, but possibly with the spark plug(s) or another component.

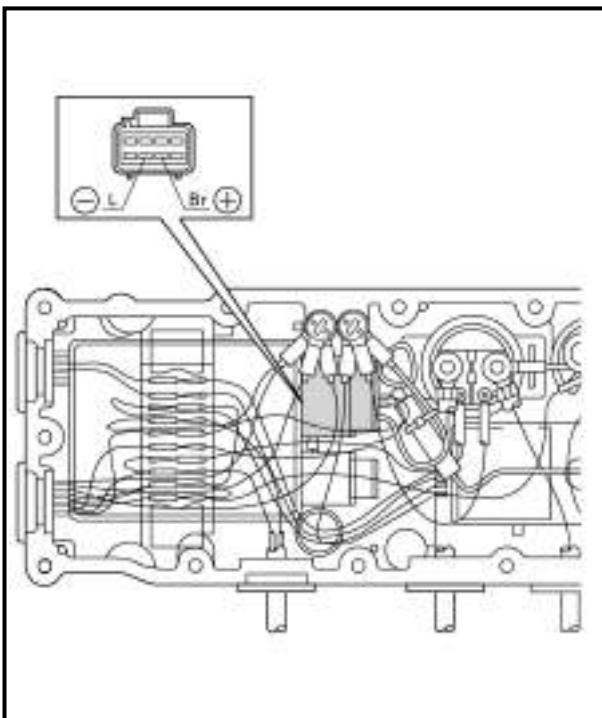
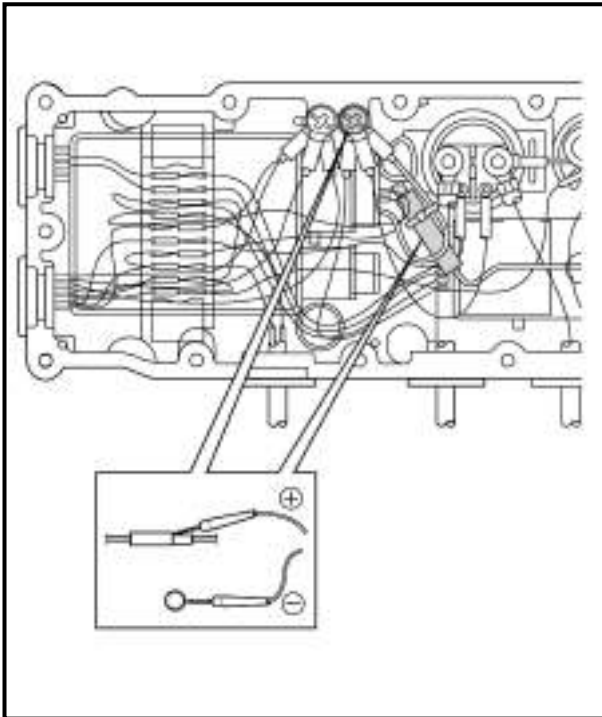

1. Measure:

- CDI unit output peak voltage
Below specification → Measure the charge coil output peak voltage or replace the CDI unit.

	CDI unit output peak voltage: Orange (O) – Black (B)			
r/min	Unloaded	Loaded		
	Cranking	2,000	3,500	
V	85	110	205	200

2. Measure:

- Charge coil output peak voltage
Below specification → Replace the charge coil.

	Charge coil output peak voltage: Brown (Br) – Blue (L)			
r/min	Unloaded	Loaded		
	Cranking	2,000	3,500	
V	90	120	220	210

	Test harness (8-pin): YW-06779/90890-06779
--	---

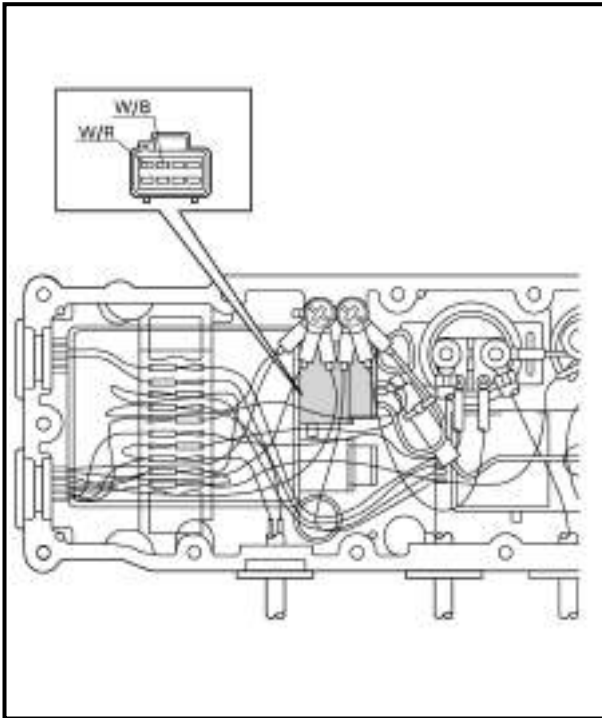
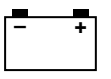

3. Measure:

- Pickup coil output peak voltage
Below specification → Replace the pickup coil.

	Pickup coil output peak voltage: White/red (W/R) – White/black (W/B)			
	r/min	Unloaded	Loaded	
		Cranking	2,000	3,500
V	5	3	7	11

	Test harness (8-pin): YW-06779/90890-06779
--	---

SPARK PLUGS

Refer to "POWER UNIT" in chapter 3.

SPARK PLUG CAPS

1. Inspect:

- Spark plug cap
Loose → Tighten.
Cracks/damage → Replace.

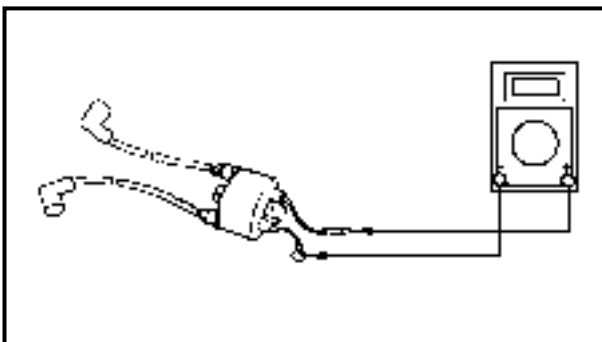
**IGNITION COIL**

1. Measure:

- Primary coil resistance
Out of specification → Replace.

	Primary coil resistance: Orange (O) – Black (B) 0.078–0.106 Ω at 20 °C (68 °F)
--	---

NOTE:

When measuring a resistance of 10 Ω or less with the digital tester, the correct measurement cannot be obtained because of the tester's internal resistance.
Refer to "Low resistance measurement".

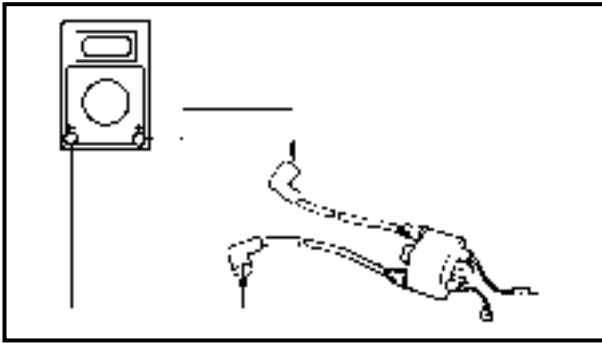
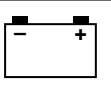

2. Measure:

- Secondary coil resistance
Out of specification → Replace.



Secondary coil resistance:
Spark plug cap – Spark plug cap
14.3–30.5 kΩ at 20 °C (68 °F)

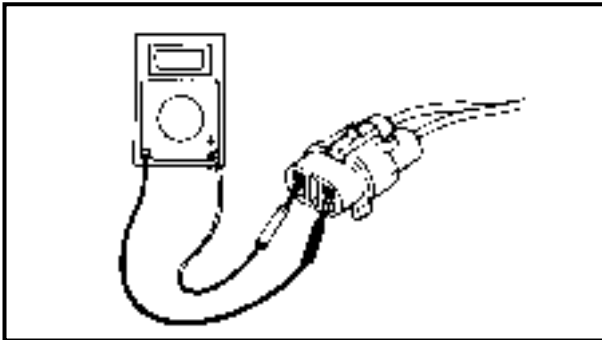

ENGINE STOP SWITCH

1. Check:

- Engine stop switch continuity
Out of specification → Replace.



Engine stop switch continuity (black coupler)

Lock plate	Position	Lead color	
		White	Black
Installed	Free		
	Push	○—○	○—○
Removed	Free	○—○	○—○
	Push	○—○	○—○

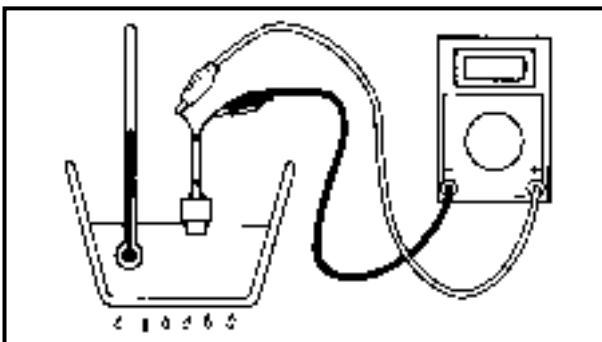

THERMOSWITCH

1. Measure:

- Thermoswitch continuity
Out of specification → Replace.



Thermoswitch continuity temperature:
Pink (P) – Black (B)
Ⓐ 80 °C (177 °F)
Ⓑ 70 °C (159 °F)

- ① No continuity Ⓐ Temperature
- ② Continuity Ⓑ Time

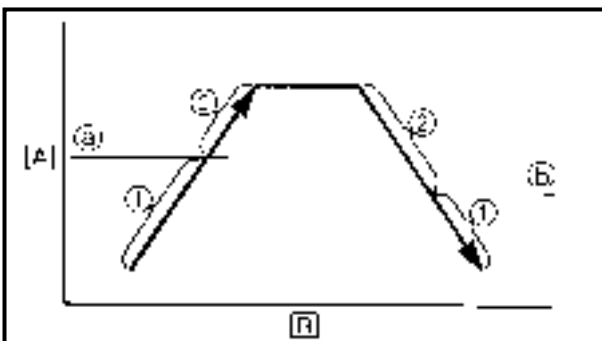

Measurement steps:

- Suspend the thermostat in a container filled with water.
- Place a thermometer in the water.
- Slowly heat the water.
- Measure the continuity when the specified temperature is reached.

**STARTING SYSTEM
WIRING DIAGRAM**

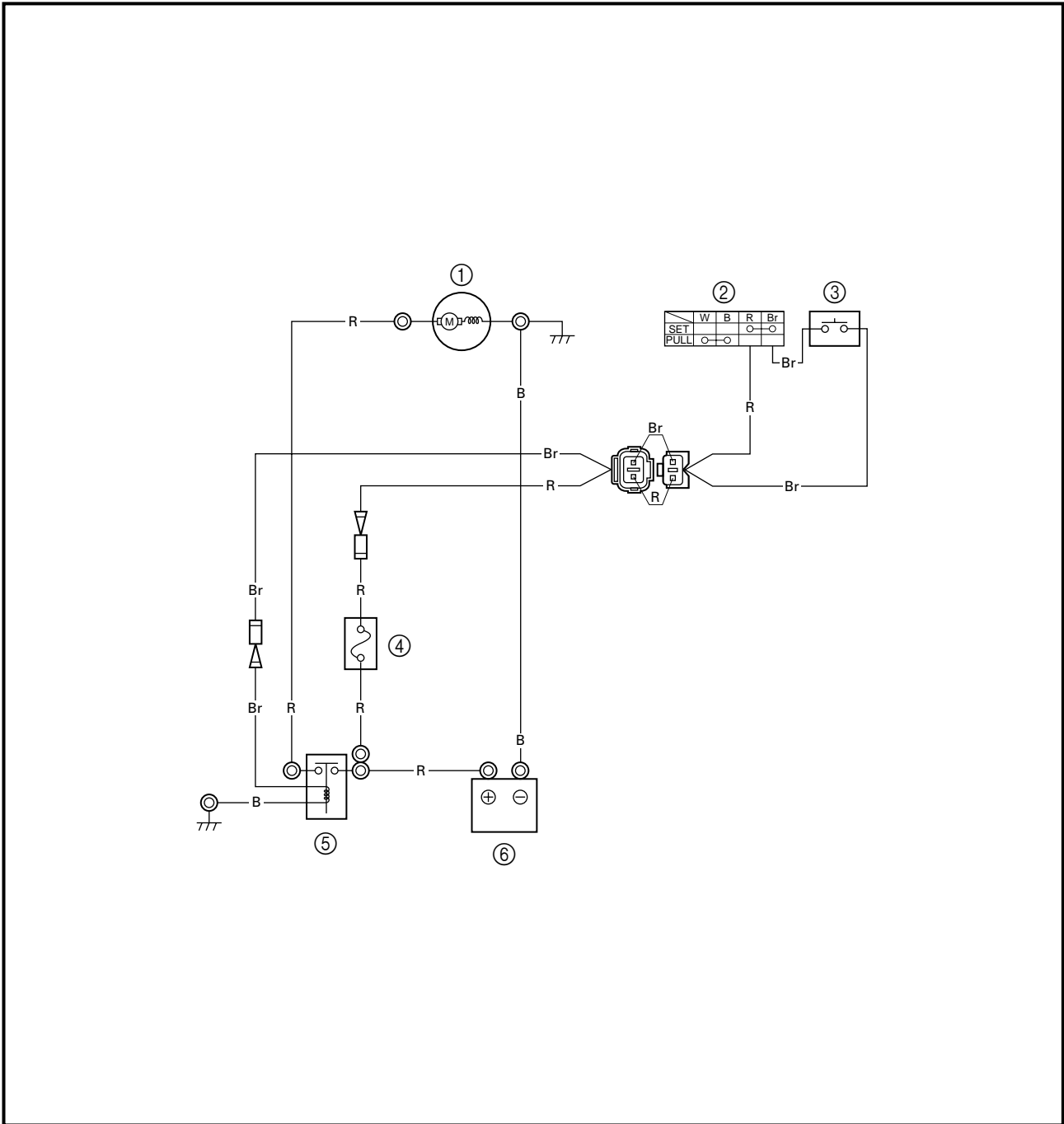

- ① Starter motor
- ② Engine stop lanyard switch
- ③ Starter switch
- ④ Fuse (10A)
- ⑤ Starter relay
- ⑥ Battery

- B : Black
- Br : Brown
- R : Red
- W : White

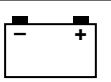

BATTERY

Refer to "ELECTRICAL" in chapter 3.

WIRING CONNECTIONS

1. Check:
 - Wiring connections

Poor connections → Properly connect.

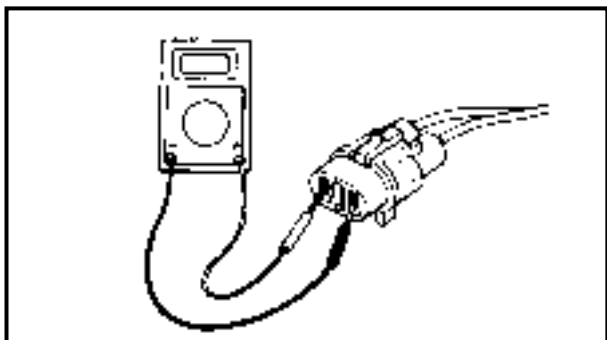
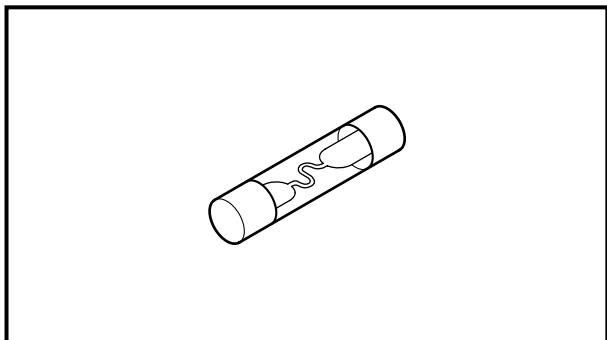
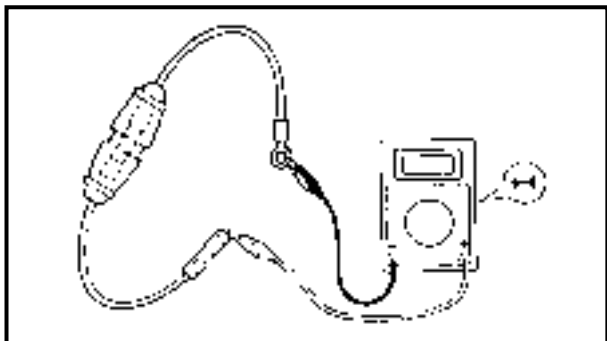

FUSE

1. Check:
 - Fuse holder continuity

No continuity → Check the fuse holder leads.
2. Check:
 - Fuse holder lead continuity

No continuity → Replace the fuse holder.

Continuity → Check the fuse.
3. Check:
 - Fuse broken

Broken → Replace.



Fuse rating:
10A

STARTER SWITCH

1. Check:
 - Continuity

Out of specification → Replace.



Starter continuity
(natural coupler)

Lock plate	Position	Leads	
		Red	Brown
Installed	Free		
	Push	○ — ○	
Removed	Free		
	Push		

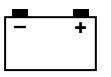

STARTER RELAY

1. Inspect:

- Brown lead terminal
 - Black lead terminal
- Loose → Tighten.

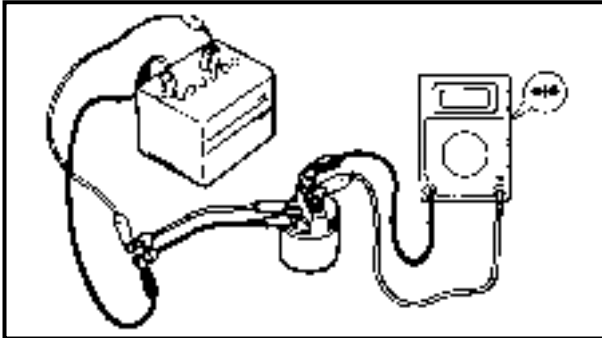

2. Check:

- Starter relay
- Faulty → Replace.

Checking steps:

- Connect the tester leads between the starter relay terminals as shown.
- Connect the brown lead terminal to the positive battery terminal.
- Connect the black lead terminal to the negative battery terminal.
- Check that there is continuity between the starter relay terminals.
- Check that there is no continuity after the brown or black lead is removed.

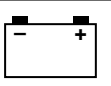

**STARTER MOTOR
EXPLODED DIAGRAM**

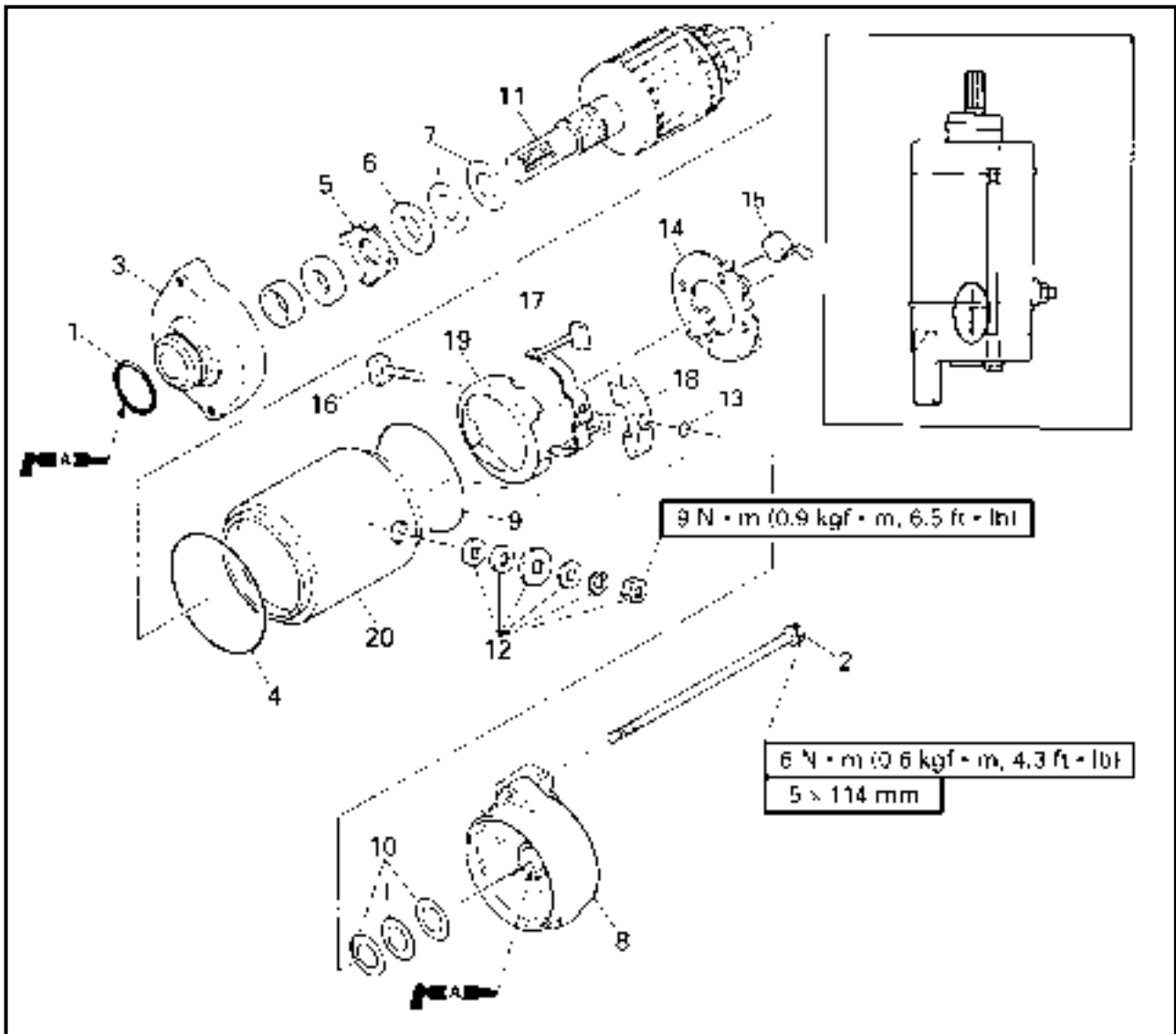

REMOVAL AND INSTALLATION CHART

Step	Procedure/Part name	Q'ty	Service points
	STARTER MOTOR DISASSEMBLY		Follow the left "Step" for disassembly.
	Starter motor		Refer to "STARTER MOTOR" in chapter 5.
1	O-ring	1	Not reusable
2	Bolt	2	
3	Starter motor front cover	1	
4	O-ring	1	Not reusable
5	Oil seal retainer	1	
6	Washer	1	
7	Shim	*	t = 0.2 mm, 0.5 mm

*: As required

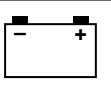

EXPLODED DIAGRAM

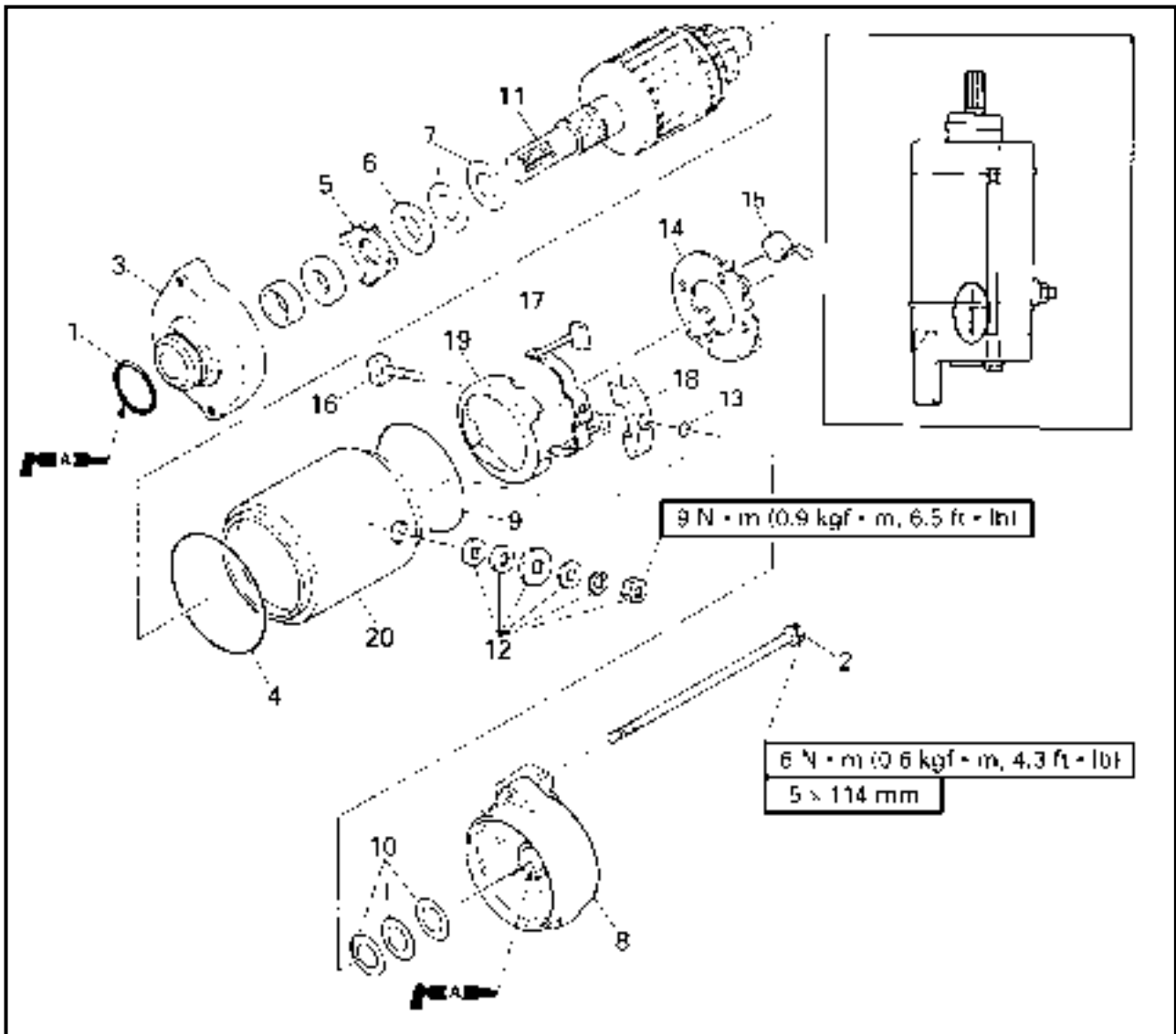

Step	Procedure/Part name	Q'ty	Service points
8	Starter motor rear cover	1	
9	O-ring	1	Not reusable
10	Shim	*	t = 0.2 mm, 0.8 mm
11	Armature assembly	1	
12	Nut/spring washer/washer	1/1/4	
13	O-ring	1	Not reusable
14	Brush holder	1	
15	Brush spring	4	
16	Bolt	1	
17	Brush assembly	1	

*: As required

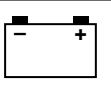

EXPLODED DIAGRAM

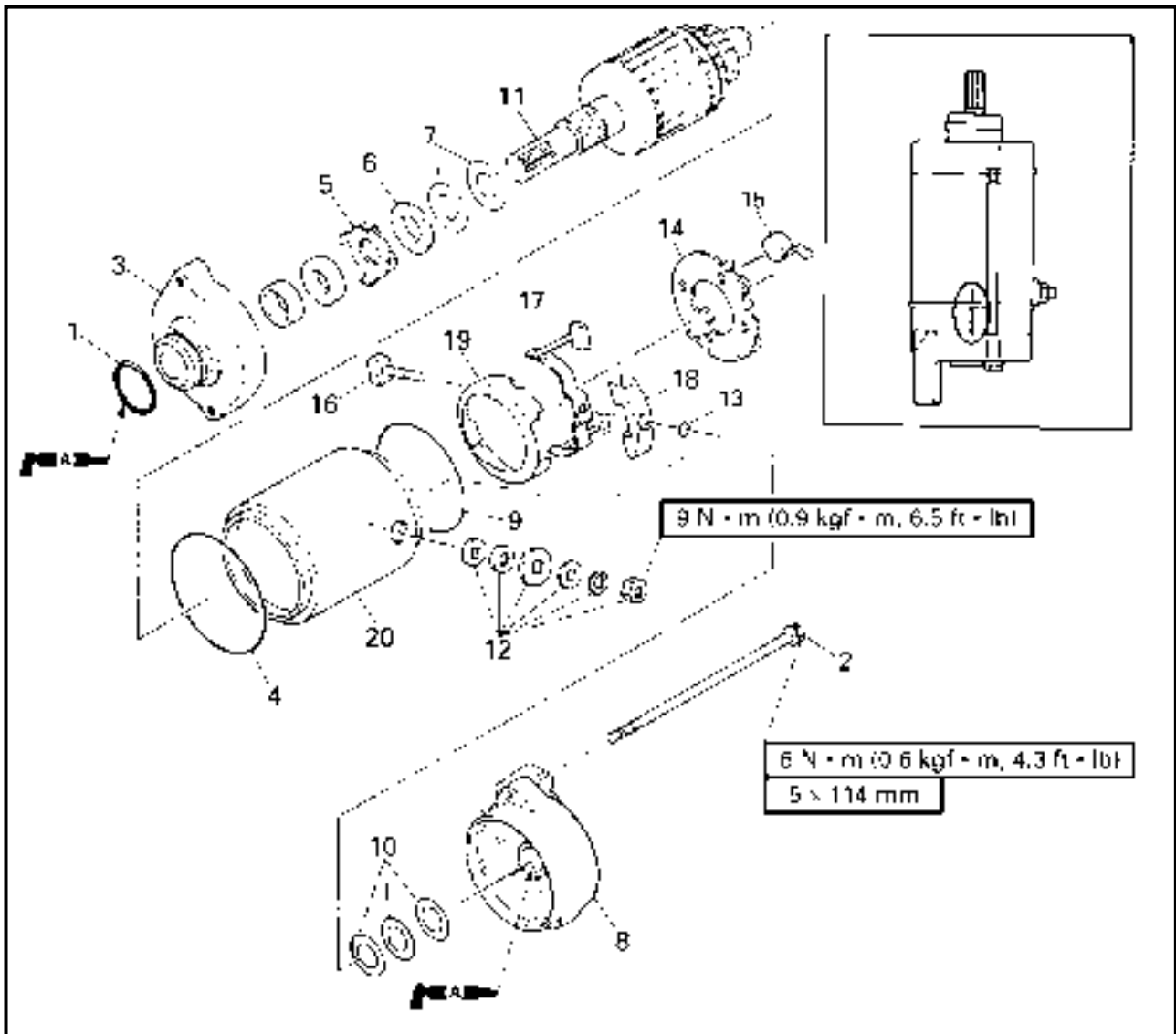

Step	Procedure/Part name	Q'ty	Service points
18	Spacer	1	Reverse the disassembly steps for assembly.
19	Holder	1	
20	Starter motor yoke	1	

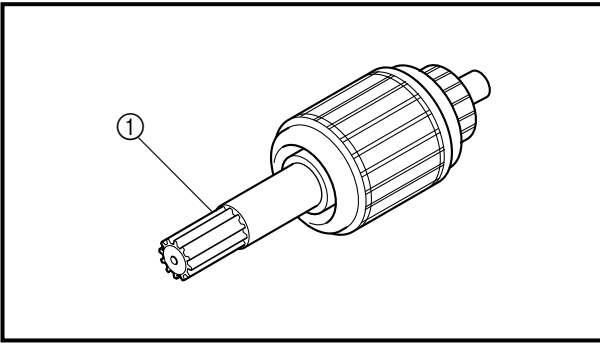
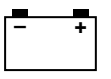
**SERVICE POINTS****Armature inspection**

1. Inspect:

- Armature shaft ①
Damage/wear → Replace.

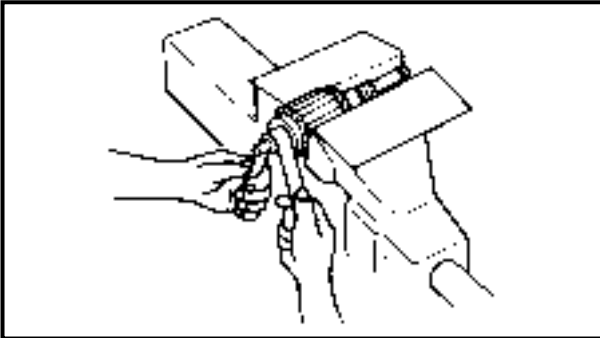

2. Inspect:

- Commutator
Dirt → Clean with 600 grit sandpaper.

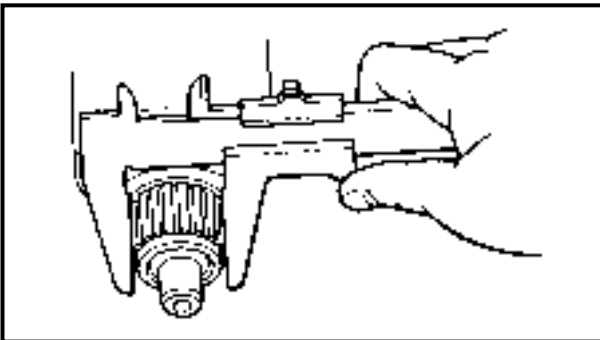

3. Measure:

- Commutator diameter
Out of specification → Replace.



Min. commutator diameter:
27.0 mm (1.06 in)

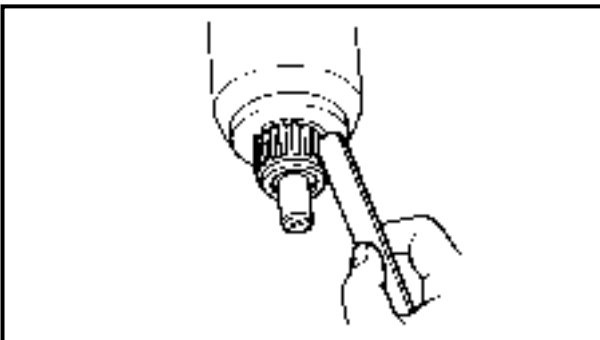

4. Check:

- Commutator undercut
Contaminants → Clean.

NOTE:

Remove all mica and metal particles with compressed air.

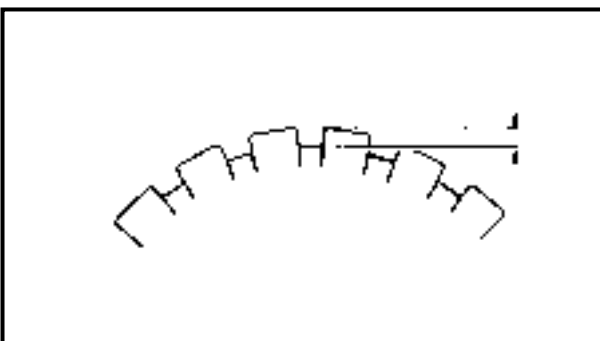

5. Measure:

- Commutator undercut
Out of specification → Replace.



Min. commutator undercut:
0.2 mm (0.01 in)

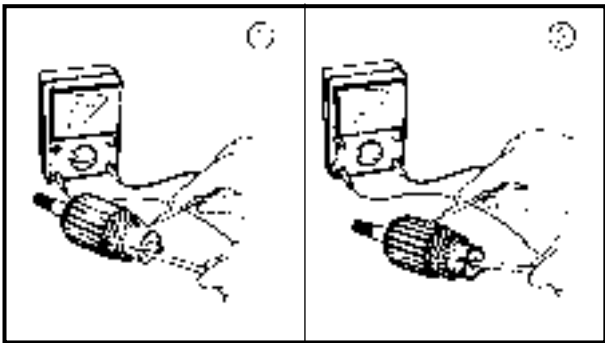
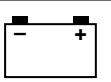

6. Inspect:
- Armature coil continuity
Out of specification → Replace.

 Armature coil continuity:	
Commutator segments ①	Continuity
Segment - Laminations ②	No continuity
Segment - Armature shaft	No continuity

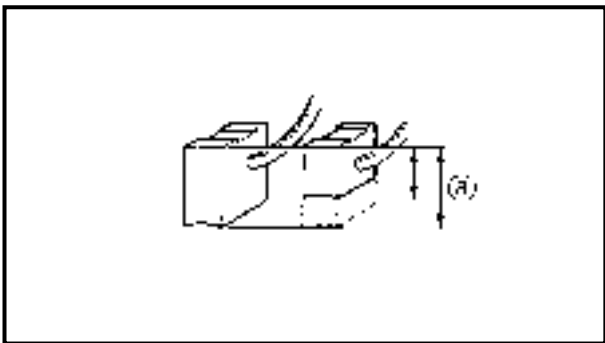

- Brush holder inspection**
1. Measure:
- Brush length ③
Out of specification → Replace.

	Min. brush length: 6.5 mm (0.26 in)
---	--

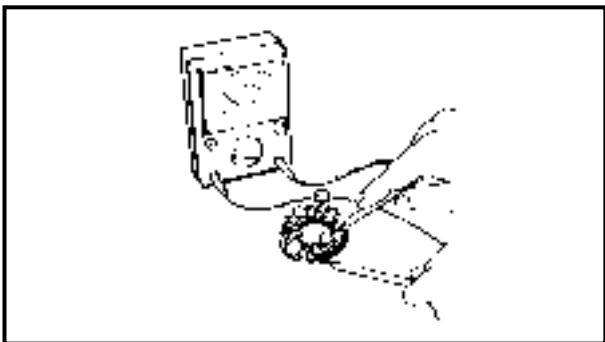

2. Check:
- Brush holder continuity
Out of specification → Replace.

 Brush holder continuity:	
Brush holder - Base	No continuity

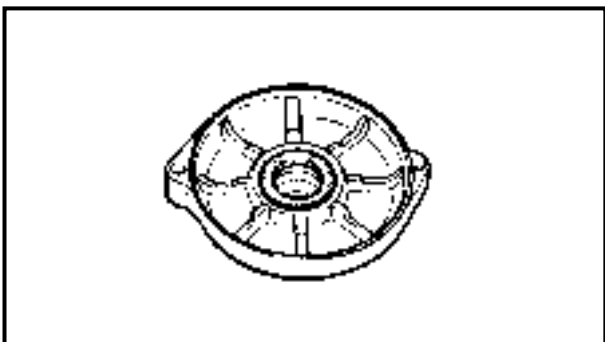

- Starter motor front cover inspection**
1. Inspect:
- Starter motor front cover bushing
Damage/wear → Replace the starter motor front cover.

**CHARGING SYSTEM
WIRING DIAGRAM**

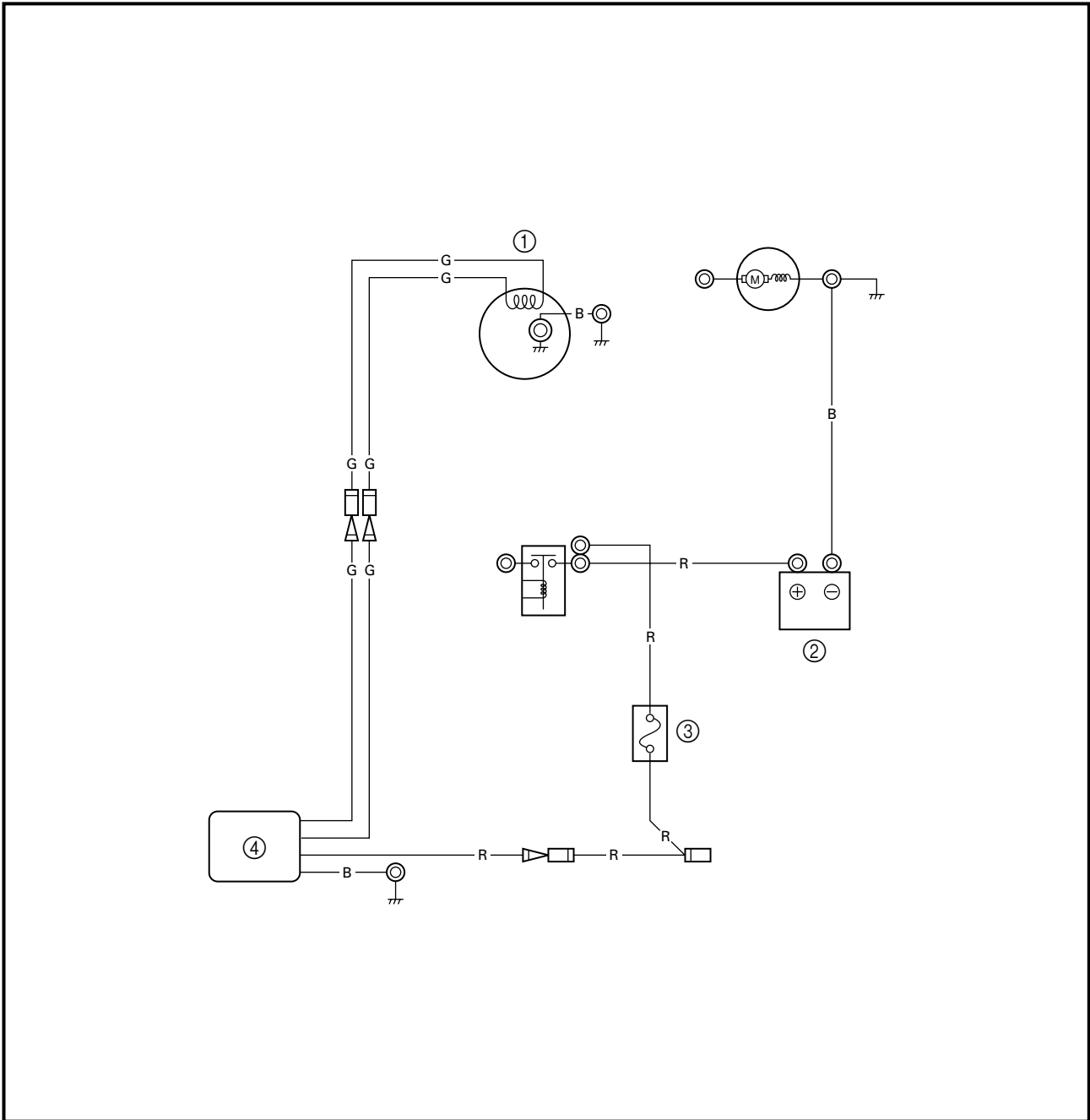

- ① Lighting coil
- ② Battery
- ③ Fuse (10A)
- ④ Rectifier/regulator

- B : Black
- G : Green
- R : Red
- G/W : Green/white

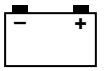

FUSE

Refer to "STARTING SYSTEM".

BATTERY

Refer to "ELECTRICAL" in chapter 3.

RECTIFIER/REGULATOR PEAK VOLTAGE

1. Measure:

- Rectifier/regulator output peak voltage

Below specification → Measure the lighting coil output peak voltage or replace the rectifier/regulator.

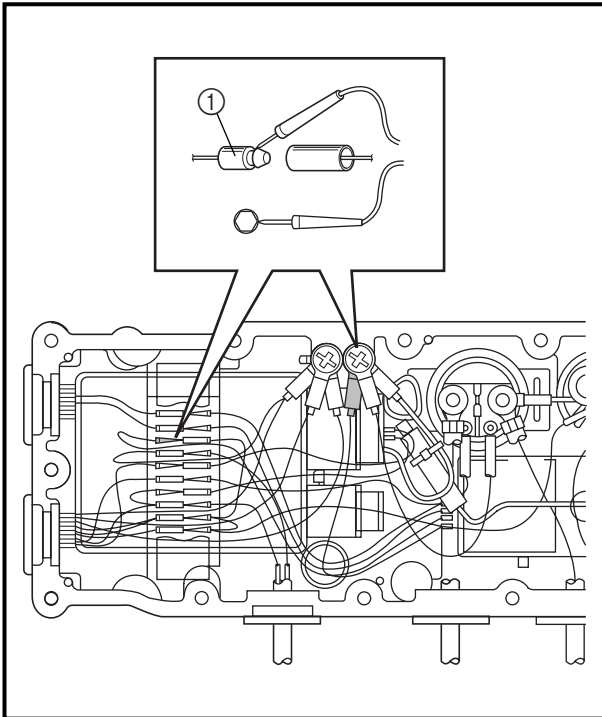

	Rectifier/regulator output peak voltage: Red (R) – Black (B)		
r/min	Unloaded		
	Cranking	2,000	3,500
V	7.5	12.5	12.5

NOTE:

Make sure the output lead (red lead) ① of the rectifier/regulator is disconnected when measuring the output peak voltage.

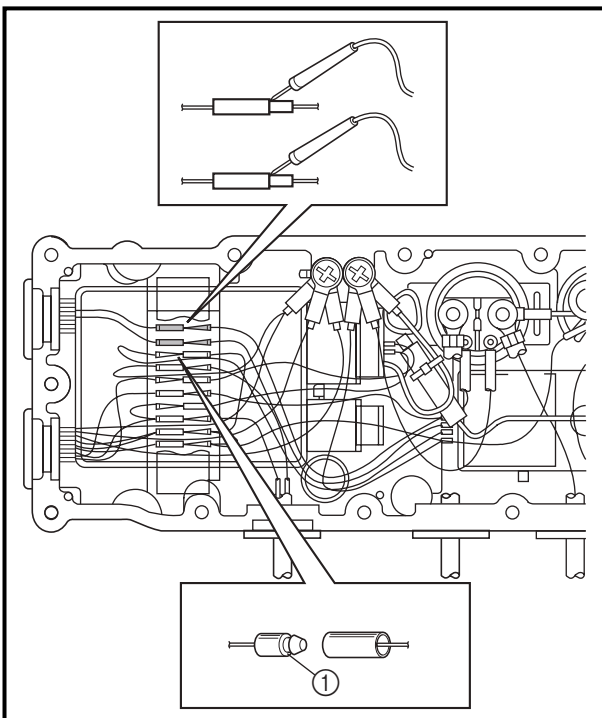

LIGHTING COIL PEAK VOLTAGE

1. Measure:

- Lighting coil output peak voltage

Below specification → Replace the lighting coil.

	Lighting coil output peak voltage: Green (G) – Green (G)		
r/min	Unloaded	Loaded	
	Cranking	2,000	3,500
V	8.5	8.5	13

NOTE:

Make sure the output lead (red lead) ① of the rectifier/regulator is disconnected when measuring the output peak voltage.

**YPVS
WIRING DIAGRAM**

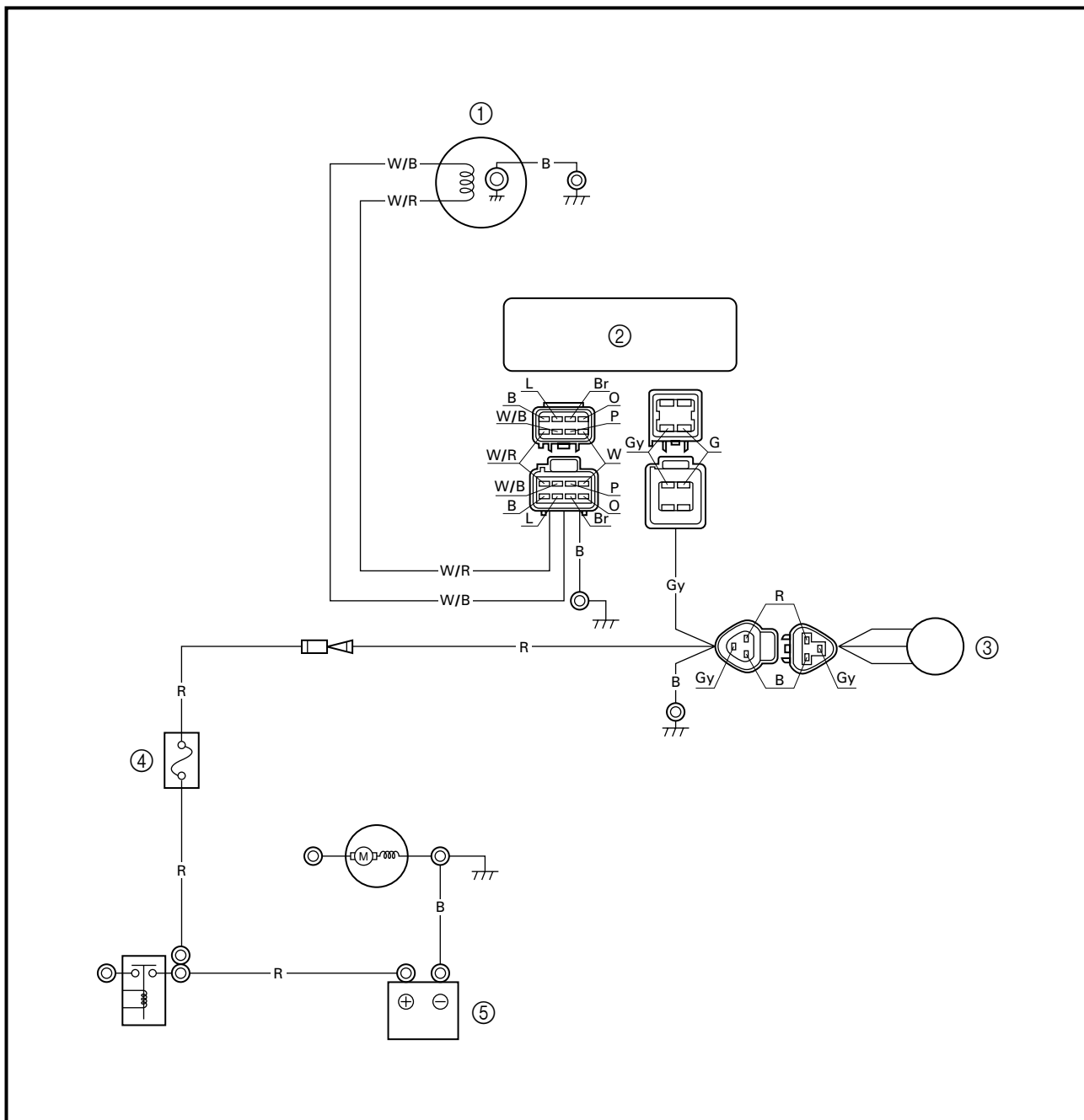

- ① Pickup coil
- ② CDI unit
- ③ YPVS servomotor
- ④ Fuse (10A)
- ⑤ Battery

- B : Black
- Br : Brown
- G : Green
- Gy : Gray
- L : Blue
- O : Orange
- P : Pink
- R : Red
- W : White
- W/B : White/black
- W/R : White/red

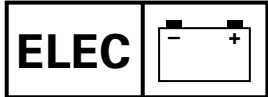

FUSE

Refer to "STARTING SYSTEM".

BATTERY

Refer to "ELECTRICAL" in chapter 3.

PICKUP COIL

Refer to "IGNITION SYSTEM".

CDI UNIT

Refer to "IGNITION SYSTEM".

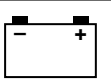

**YPVS SERVOMOTOR
EXPLODED DIAGRAM**

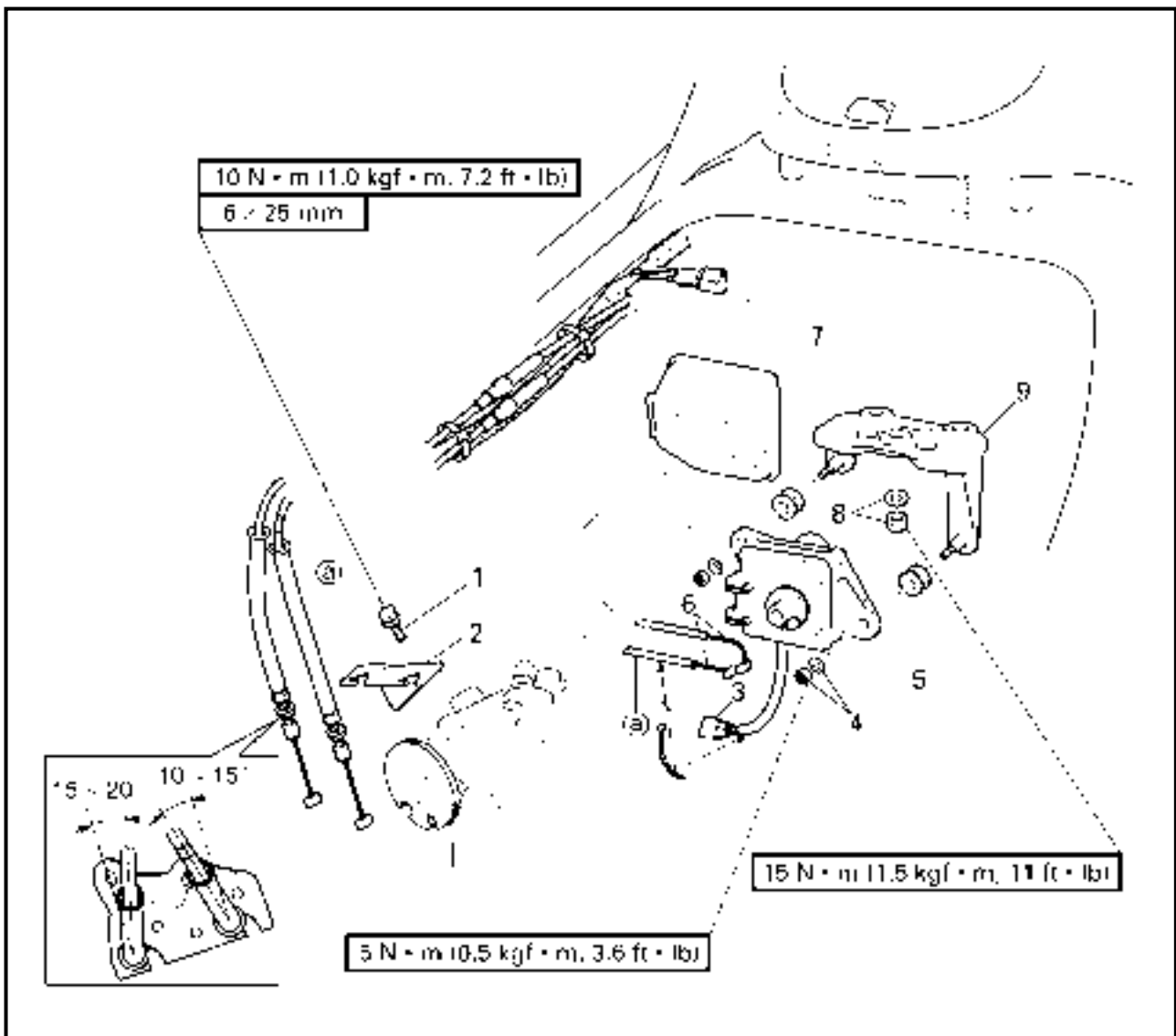

REMOVAL AND INSTALLATION CHART

Step	Procedure/Part name	Q'ty	Service points
YPVS SERVOMOTOR REMOVAL			Follow the left "Step" for removal.
1	Bolt	2	
2	Cable holder	1	
3	YPVS servomotor coupler	1	
4	Nut/washer	2/2	
5	YPVS servomotor	1	
6	YPVS cable	2	Slide the cover. White paint mark (a) is for No. 2 cable.
7	Cover	1	
8	Nut/washer	3/3	
9	YPVS servomotor bracket	1	
			Reverse the removal steps for installation.

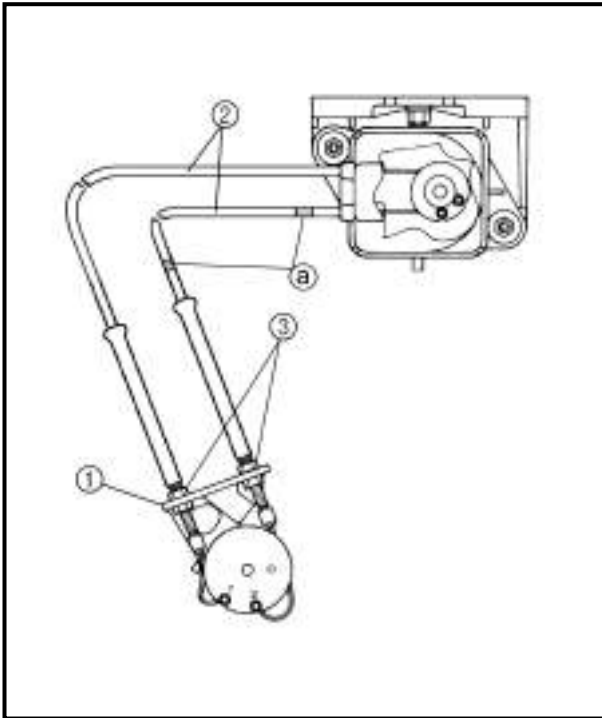
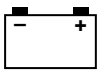

SERVICE POINTS

YPVS cable removal and installation

1. Remove:

- YPVS cables 1 and 2

Removal steps:

- Remove the YPVS cable holder ①.
- Remove the YPVS cables ② from the both drams.

NOTE:

- There is a white paint mark ① on YPVS cable 2.
- When installing the YPVS cable, make sure that the YPVS cable locknuts ③ are fully turned in.

YPVS cable inspection

1. Inspect:

- YPVS cables 1 and 2
- Frays/kinks/rough movement →
Replace.

YPVS servomotor inspection

1. Check:

- YPVS servomotor
- YPVS servomotor does not move →
Replace.

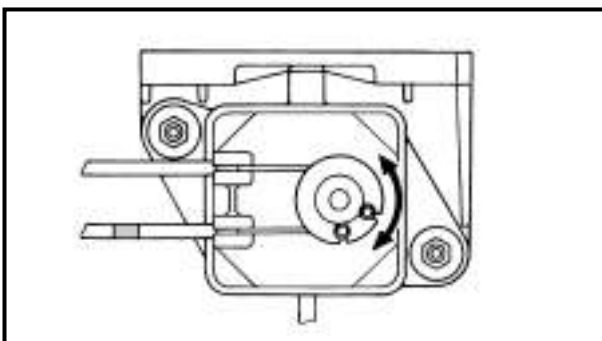
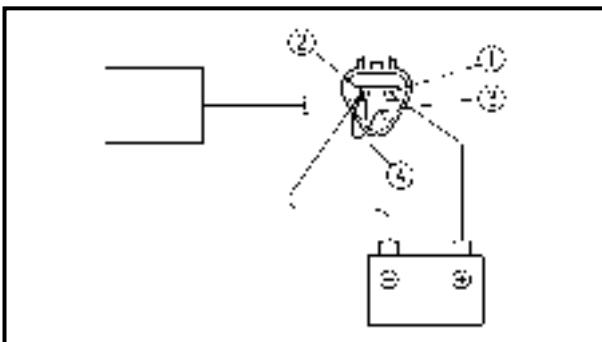

Checking steps:

- Connect the battery (12 V) to the YPVS servomotor coupler as shown.

Battery positive terminal →

Red (R) terminal ①

Battery negative terminal →

Black (B) terminal ②

- Install a jumper lead ④ between the black ② and gray ③ terminals as shown. Only install the jumper lead for 1 or 2 seconds.

Black (B) terminal ② ↔

Gray (Gy) terminal ③

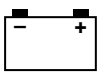

- Make sure the servomotor operates properly.

NOTE: _____

Make sure the pulley operates three seconds after the jumper lead is removed.

CAUTION: _____

Do not disassemble the YPVS servomotor unit. It is a sealed unit and if it is faulty it must be replaced.

YPVS cable adjustment

Refer to "CONTROL SYSTEM" in chapter 3.

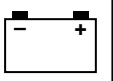

**INDICATION SYSTEM
WIRING DIAGRAM**

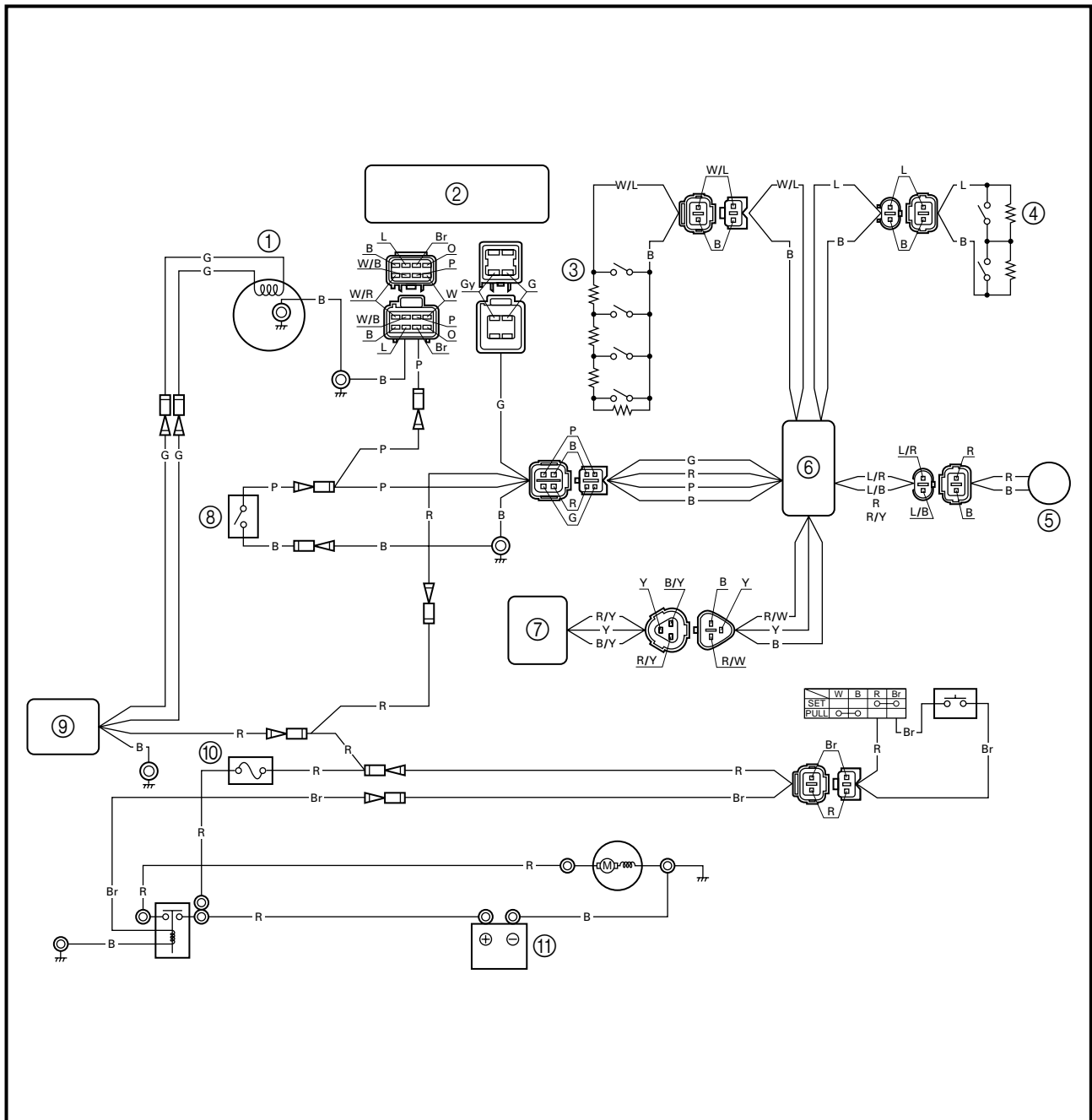

- ① Lighting coil
- ② CDI unit
- ③ Fuel level sensor
- ④ Oil level sensor
- ⑤ Buzzer
- ⑥ Multifunction meter
- ⑦ Speed sensor
- ⑧ Thermoswitch
- ⑨ Rectifier/regulator
- ⑩ Fuse (10A)
- ⑪ Battery

- B : Black
- Br : Brown
- G : Green
- Gy : Gray
- L : Blue
- O : Orange
- P : Pink
- R : Red
- W : White
- Y : Yellow
- B/Y : Black/yellow

- L/B : Blue/black
- L/R : Blue/red
- R/B : Red/black
- R/W : Red/white
- R/Y : Red/yellow
- W/B : White/black
- W/L : White/blue
- W/R : White/red

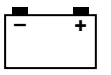

FUSE

Refer to "STARTING SYSTEM".

BATTERY

Refer to "ELECTRICAL" in chapter 3.

LIGHTING COIL

Refer to "CHARGING SYSTEM".

RECTIFIER/REGULATOR

Refer to "CHARGING SYSTEM".

CDI UNIT

Refer to "IGNITION SYSTEM".

THERMOSWITCH

Refer to "IGNITION SYSTEM".

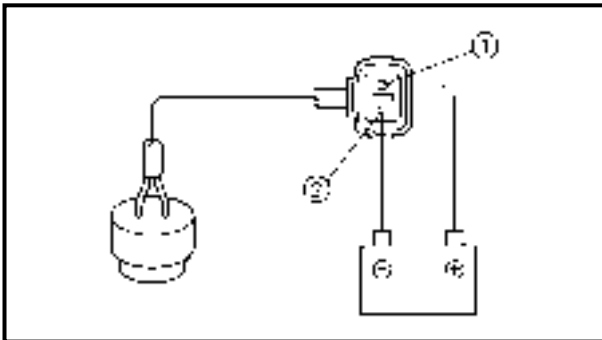

BUZZER

1. Check:

- Buzzer

Buzzer does not sound → Replace.

Checking steps:

- Connect the battery (12 V) to the buzzer coupler as shown.

Battery positive terminal →

Red (R) terminal ①

Battery negative terminal →

Black (B) terminal ②

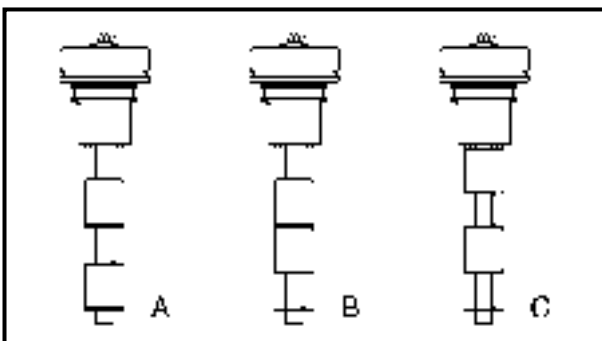

OIL LEVEL SENSOR

1. Measure:

- Oil level sensor resistance

Out of specification → Replace.

Blue (L) – Black (B)		
	Float position	Resistance (Ω)
	A	292–308
	B	97–103
	C	0–3

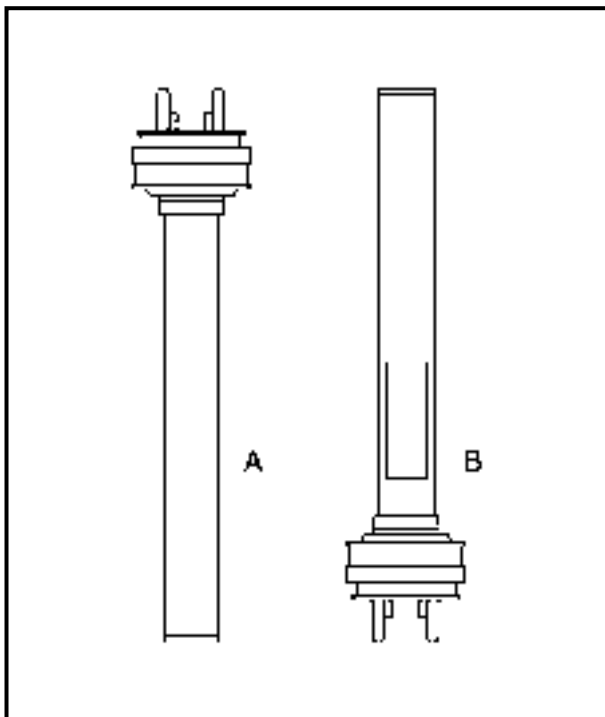
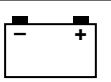

FUEL LEVEL SENSOR

1. Measure:

- Fuel level sensor resistance
Out of specification → Replace.

White/blue (W/L) – Black (B)	
 Float position	Resistance (Ω)
A	757–803
B	0–8

MULTIFUNCTION METER

Multifunction meter

1. Check:

- Multifunction meter
Cracked meter housing → Replace the multifunction meter.
Meter is fogged/shows signs of water intrusion → Replace the multifunction meter.

MULTIFUNCTION METER REMOVAL

Refer to “STEERING CONSOLE COVER” in chapter 8.

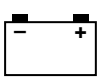

Display function

1. Check:

- Display function

Not operate → Replace the multifunction meter.

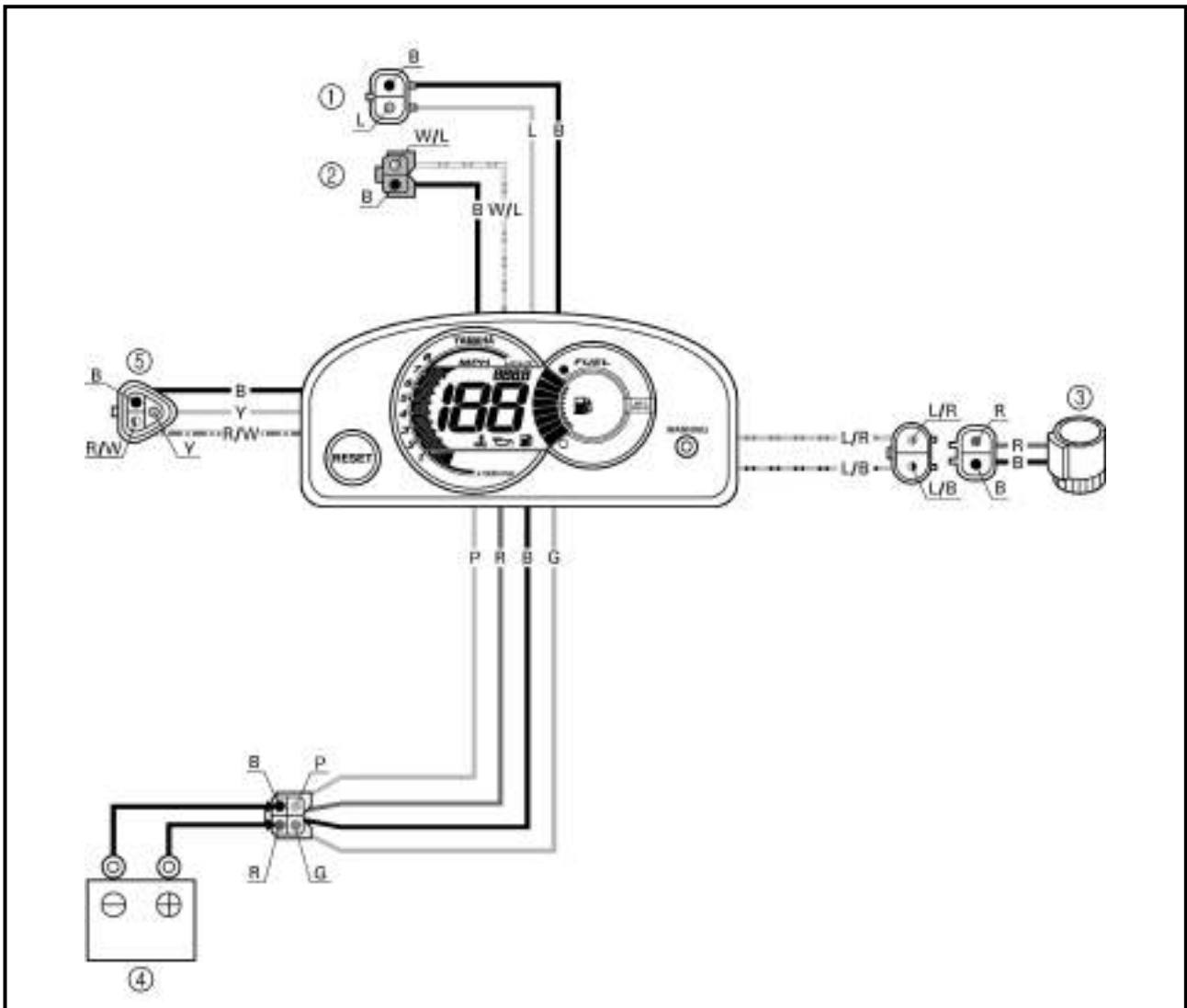

- ① Oil level sensor
- ② Fuel level sensor
- ③ Buzzer
- ④ Battery
- ⑤ Speed sensor

B : Black
 G : Green
 L : Blue
 P : Pink
 R : Red
 Y : Yellow
 L/B : Blue/black
 L/R : Blue/red
 R/W : Red/white
 W/L : White/blue

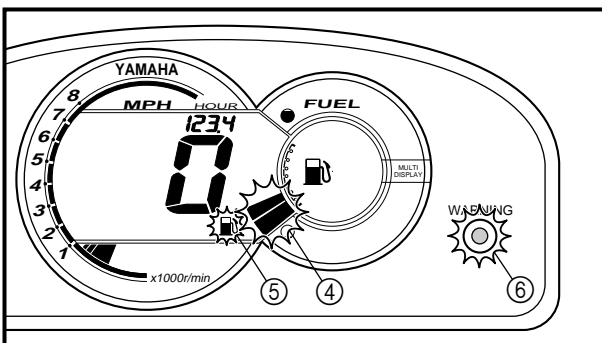
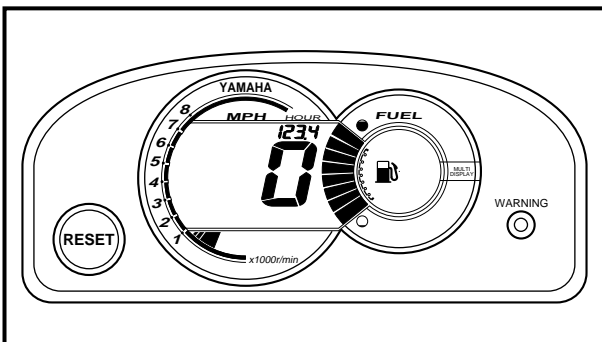
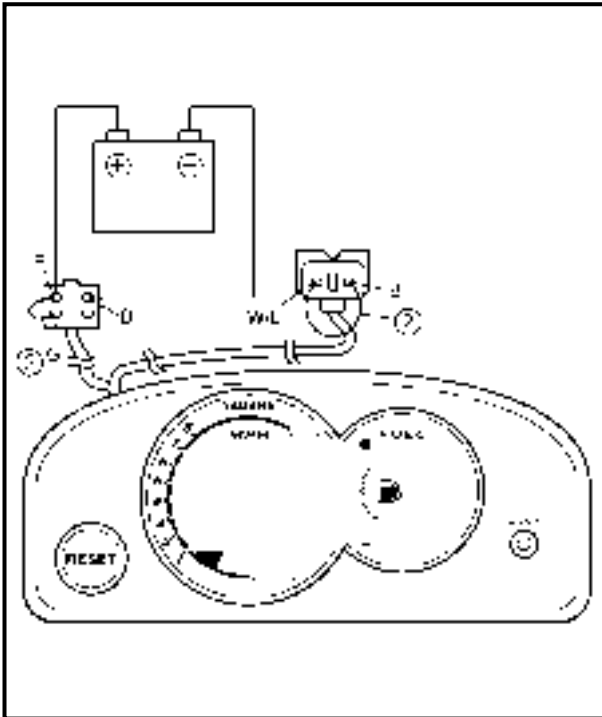
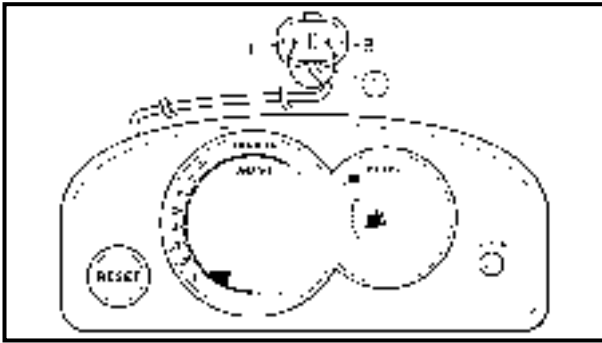
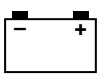

Fuel level gauge

1. Check:

- Fuel level gauge
Not operating → Replace the multi-function meter.

NOTE:

When inspecting the multifunction meter unit or emptying the oil tank, connect the blue and black terminals (white two-pin connector) with a jumper lead ① to prevent the oil warning indicator from being activated.

Checking steps:

- Supply DC 12 voltage to the white four-pin connector (+: red, -: black) with a battery.
- Disconnect the green two-pin connector (white/blue and black leads).
- Connect the white/blue and black terminals with a jumper lead ②.
- Connect the green and red terminals with a jumper lead ③.

NOTE:

If the jumper lead is installed for more than 30 seconds, the display will automatically turn off.

- Check the fuel level segments is full indicated.
- Remove the jumper lead ② from the green two-pin connector.
- Disconnect the jumper lead ③ and then connect it to green and red terminal again.
- Make sure the fuel level segment ④, fuel symbol ⑤ and "WARNING" lamp ⑥ blinks, and the buzzer sounds intermittently.

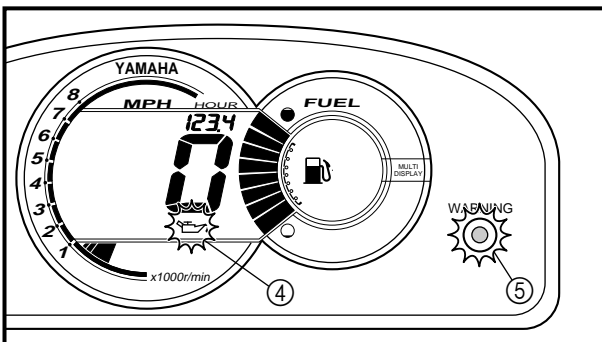
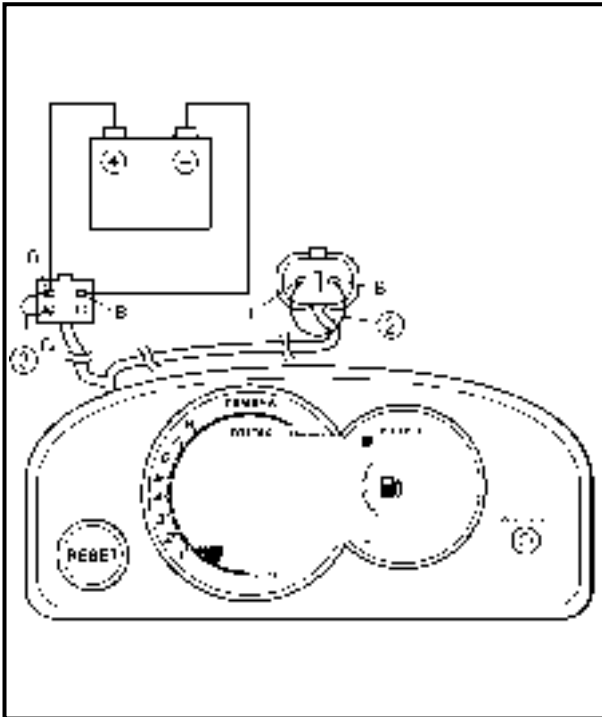
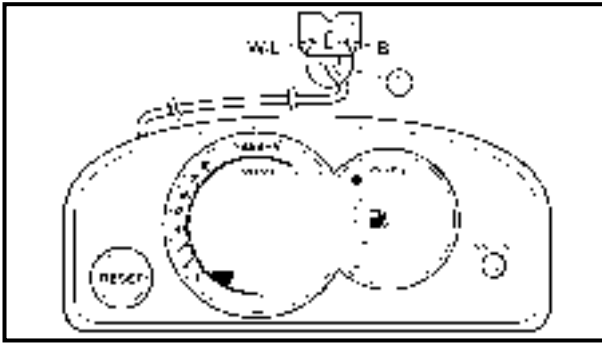
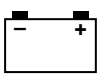

Oil level gauge

1. Check:

- Oil level gauge
Not operating → Replace the multi-function meter.

NOTE:

When inspecting the multifunction meter unit or emptying the fuel tank, connect the white/blue and black terminals (green two-pin connector) with a jumper lead ① to prevent the fuel warning indicator from being activated.

Checking steps:

- Supply DC 12 voltage to the white four-pin connector (+: red, -: black) with a battery.
- Disconnect the white two-pin connector (blue and black leads).
- Connect the blue and black terminals with a jumper lead ②.
- Connect the green and red terminals with a jumper lead ③.

NOTE:

If the jumper lead is installed for more than 30 seconds, the display will automatically turn off.

- Remove the jumper lead ② from the white two-pin connector.
- Disconnect the jumper lead ③ and then connect it to green and red terminal again.
- Make sure the oil symbol ④ and "WARNING" lamp ⑤ blinks, and the buzzer sounds intermittently.

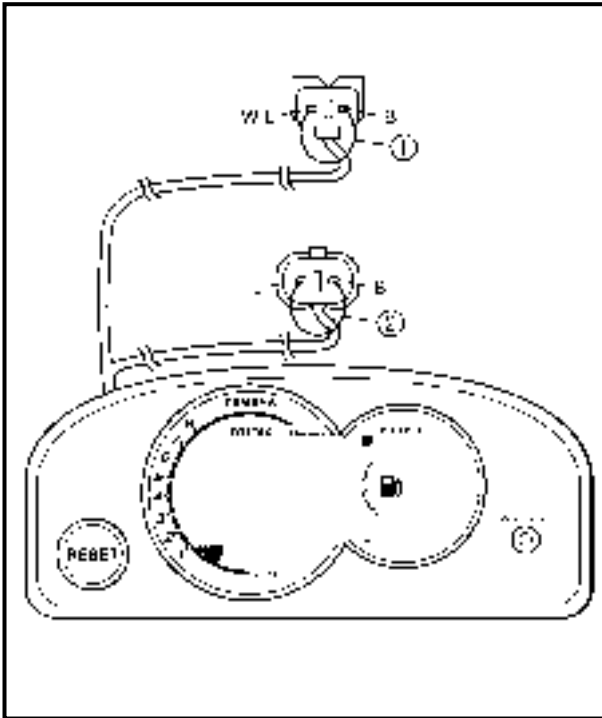
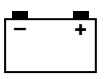

Overheat warning indicator

1. Check:

- Overheat warning indicator
Not operating → Replace the multi-function meter.

NOTE:

- When inspecting the multifunction meter unit or emptying the fuel tank, connect the white/blue and black terminals (green two-pin connector) with a jumper lead ① to prevent the fuel warning indicator from being activated.
- When inspecting the multifunction meter unit or emptying the oil tank, connect the blue and black terminals (white two-pin connector) with a jumper lead ② to prevent the oil warning indicator from being activated.

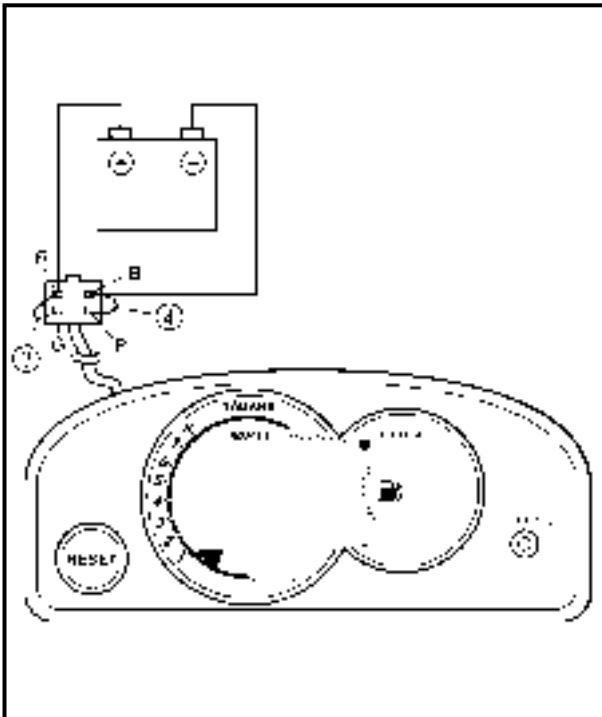

Checking steps:

- Supply DC 12 voltage to the white four-pin connector (+: red, -: black) with a battery.
- Connect the green and red terminals with a jumper lead ③.
- Connect the pink and black terminals with a jumper lead ④.
- Make sure the water temperature symbol ⑤ and "WARNING" lamp ⑥ blinks, and the buzzer sounds intermittently.

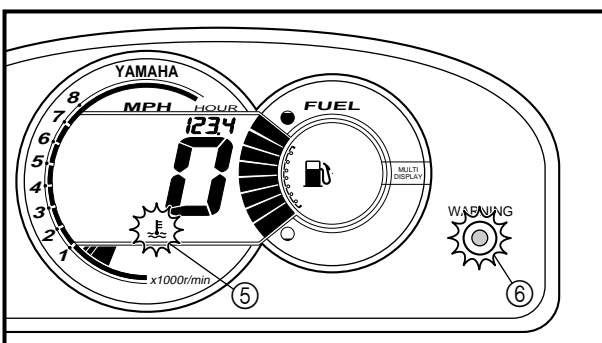

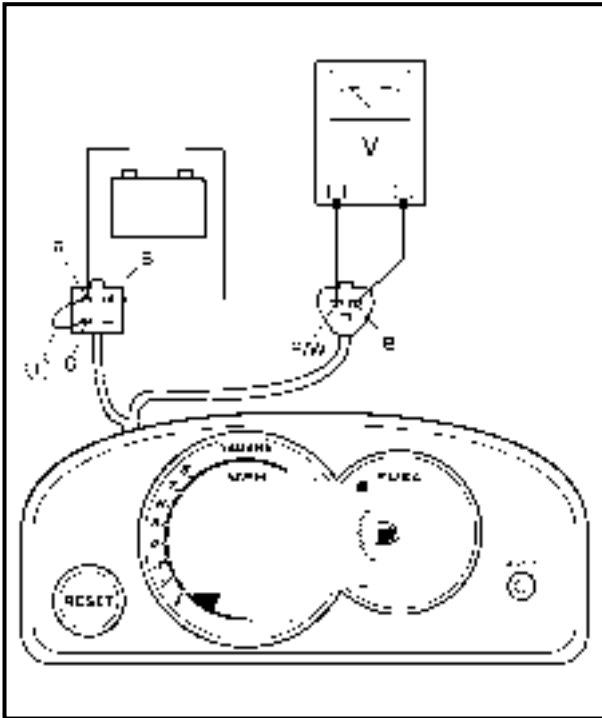
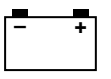

Speed meter

1. Check:

- Speed meter output voltage
Within specification → Check the speed sensor output voltage and pulses.
Out of specification → Replace.



**Speed meter output voltage:
10.5 V**

NOTE:

- When inspecting the multifunction meter unit or emptying the fuel tank, connect the white/blue and black terminals (green two-pin connector) with a jumper lead ① to prevent the fuel warning indicator from being activated.
- When inspecting the multifunction meter unit or emptying the oil tank, connect the blue and black terminals (white two-pin connector) with a jumper lead ② to prevent the oil warning indicator from being activated.

Checking steps:

- Supply DC 12 voltage to the white four-pin connector (+: red, -: black) with a battery.
- Connect the green and red terminals with a jumper lead ①.
- Measure the voltage on the speed sensor connector (white three-pin connector) between the red/white and black leads.

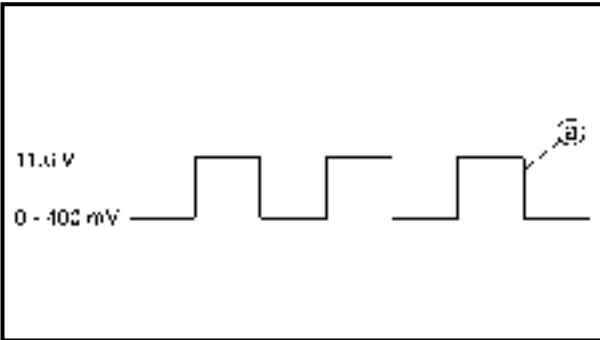
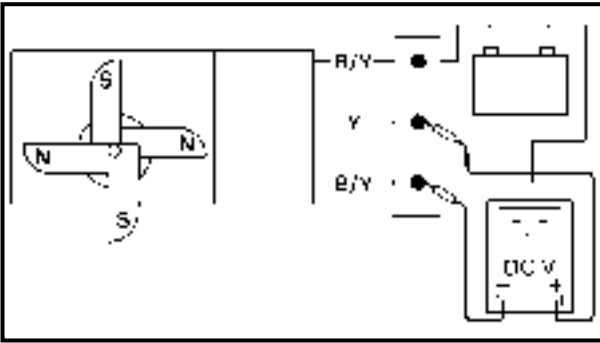
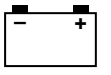

Speed sensor

1. Check:

- Speed sensor output voltage and pulses
- Out of specification → Replace.



Speed sensor output voltage (dependant on the paddle wheel position):

Less than 400 mV/

More than 11.6 V

Output pulse:

2 pulses/one-full turn

Checking steps:

- Apply DC 12 voltage to the white three-pin connector (between the red/yellow and black/yellow leads).
- Rotate the paddle wheel by hand and measure the voltage between the yellow and black/yellow leads.

NOTE:

As the paddle wheel is rotated, a square-wave voltage signal ① is produced.

- Two pulses occur every time the paddle wheel makes one-full turn.

CHAPTER 8 HULL AND HOOD

HANDLEBAR	8-1
EXPLODED DIAGRAM.....	8-1
REMOVAL AND INSTALLATION CHART	8-1
SERVICE POINTS	8-7
Handlebar inspection.....	8-7
Handlebar switch inspection.....	8-7
Handlebar assembly installation	8-7
 QSTS GRIP	 8-10
EXPLODED DIAGRAM.....	8-10
REMOVAL AND INSTALLATION CHART	8-10
SERVICE POINTS	8-12
QSTS cable inspection.....	8-12
QSTS grip inspection.....	8-12
 STEERING COLUMN	 8-13
EXPLODED DIAGRAM.....	8-13
REMOVAL AND INSTALLATION CHART	8-13
SERVICE POINTS	8-16
Steering column bushing inspection	8-16
 REMOTE CONTROL CABLES AND SPEED SENSOR LEAD	 8-17
EXPLODED DIAGRAM.....	8-17
REMOVAL AND INSTALLATION CHART	8-17
SERVICE POINTS	8-20
Remote control cables inspection	8-20
Steering cable (jet pump side) installation	8-20
Steering cable stopper installation.....	8-20
QSTS cable (jet pump side) installation.....	8-21
QSTS cable stopper installation	8-21
 FRONT HOOD	 8-22
EXPLODED DIAGRAM.....	8-22
REMOVAL AND INSTALLATION CHART	8-22
 STEERING CONSOLE COVER	 8-24
EXPLODED DIAGRAM.....	8-24
REMOVAL AND INSTALLATION CHART	8-24

BUZZER AND HOOD LOCK 8-28
 EXPLODED DIAGRAM 8-28
 REMOVAL AND INSTALLATION CHART 8-28

HOSES..... 8-31
 EXPLODED DIAGRAM 8-31
 REMOVAL AND INSTALLATION CHART 8-31
 SERVICE POINTS 8-33
 Check valve inspection 8-33
 Ventilation hose installation..... 8-33

SEATS AND HAND GRIP 8-34
 EXPLODED DIAGRAM 8-34
 REMOVAL AND INSTALLATION CHART 8-34
 SERVICE POINTS 8-36
 Seat lock inspection 8-36

BATTERY BOX..... 8-37
 EXPLODED DIAGRAM 8-37
 REMOVAL AND INSTALLATION CHART 8-37

EXHAUST SYSTEM..... 8-39
 EXPLODED DIAGRAM 8-39
 REMOVAL AND INSTALLATION CHART 8-39
 SERVICE POINTS 8-41
 Exhaust system inspection..... 8-41
 Exhaust component parts sub-assembly 8-41

DECK AND HULL 8-42
 EXPLODED DIAGRAM 8-42
 REMOVAL AND INSTALLATION CHART 8-42

ENGINE MOUNT 8-44
 EXPLODED DIAGRAM 8-44
 REMOVAL AND INSTALLATION CHART 8-44
 HULL REPAIR 8-45
 Shallow scratches 8-45
 Deep scratches 8-45
 Cracks and punctures 8-46
 Insert nut..... 8-47
 Graphic removal..... 8-49
 Graphic installation..... 8-49

**HANDLEBAR
EXPLODED DIAGRAM**

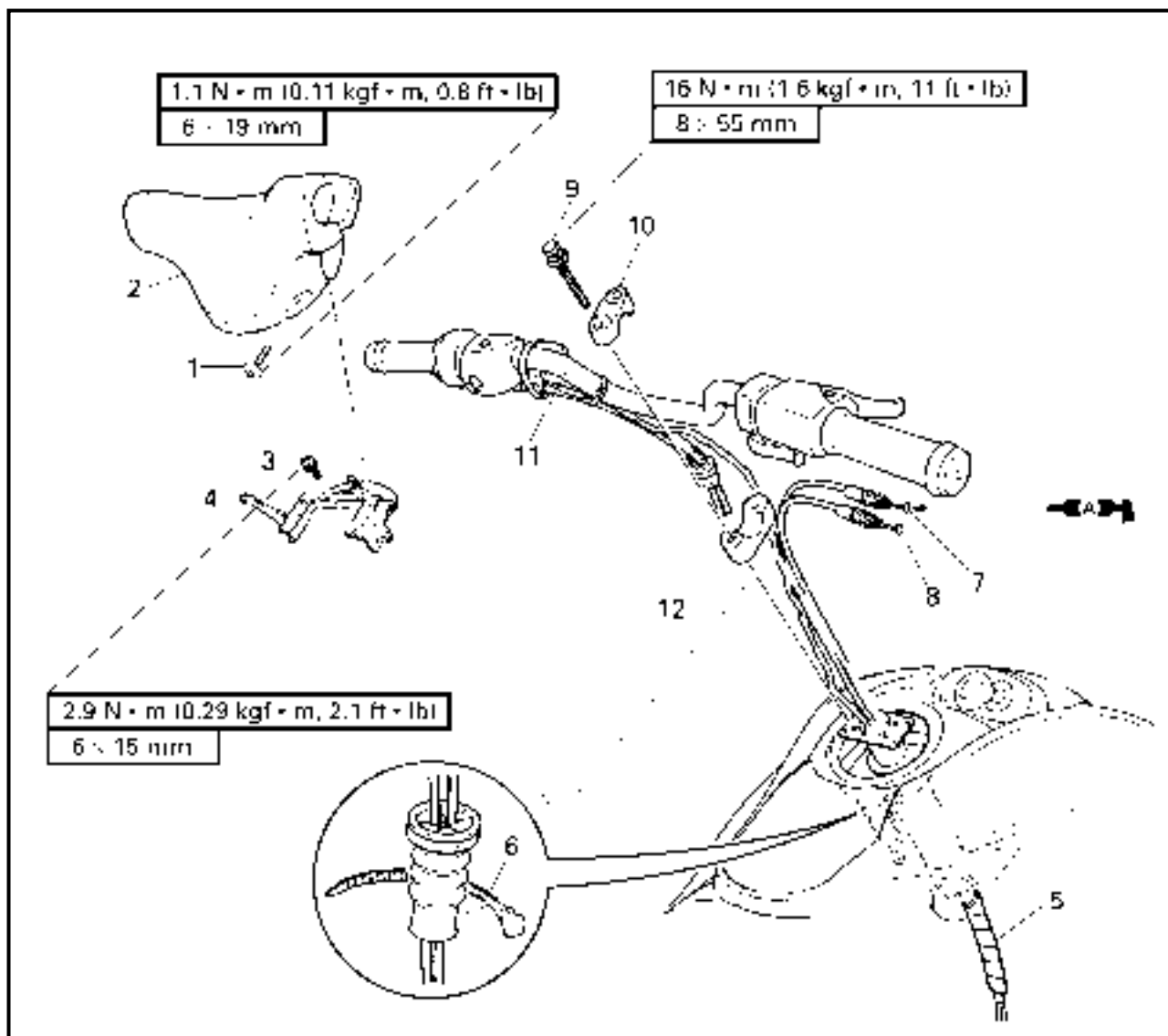

REMOVAL AND INSTALLATION CHART

Step	Procedure/Part name	Q'ty	Service points
	HANDLEBAR COVER REMOVAL		Follow the left "Step" for removal.
1	Screw	4	
2	Handlebar cover	1	
3	Screw	4	
4	Handlebar cover stay	1	
5	Spiral tube	1	
6	Band	1	

EXPLODED DIAGRAM

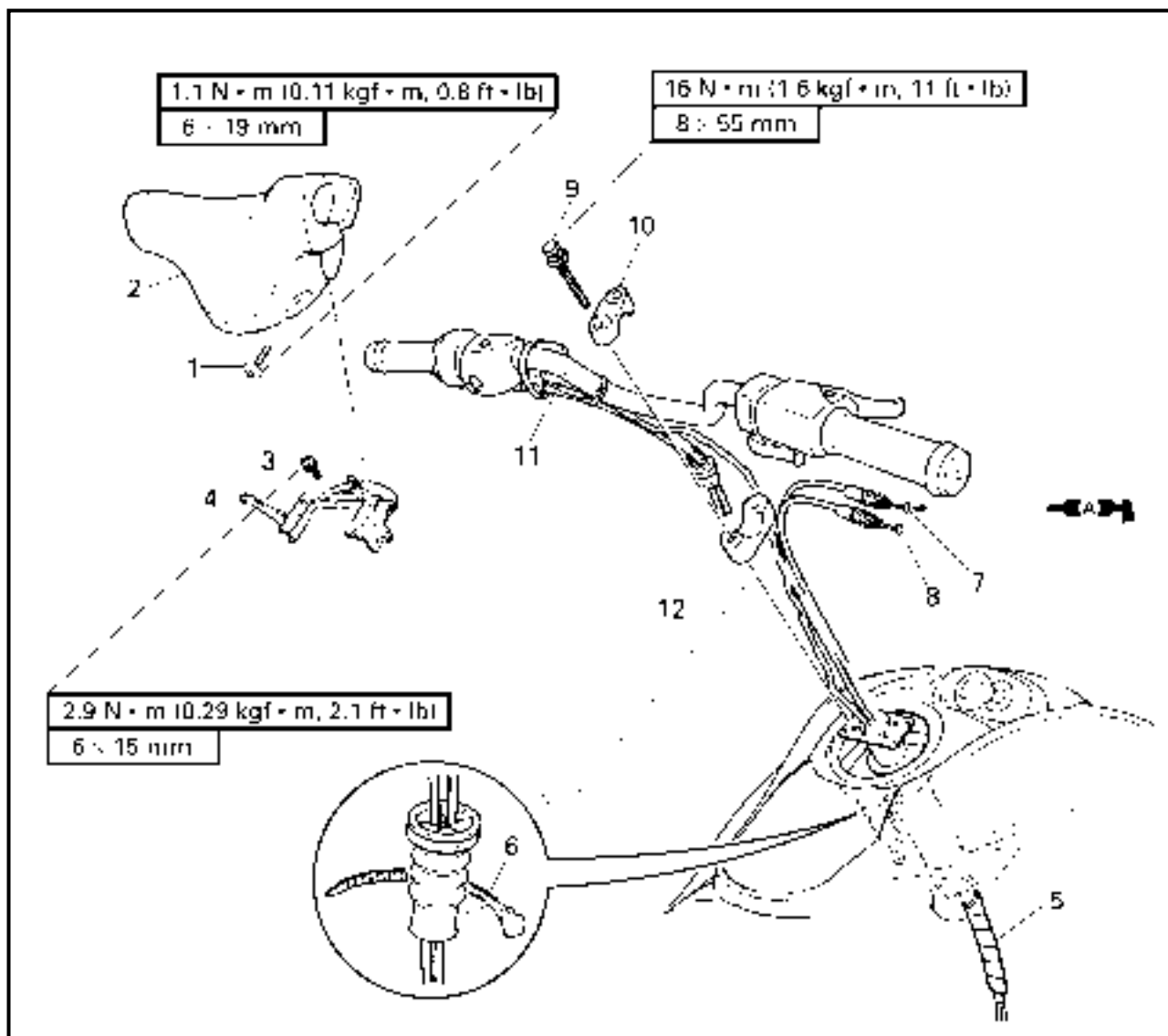

Step	Procedure/Part name	Q'ty	Service points
7	Throttle cable	1	Reverse the removal steps for installation.
8	Choke cable	1	
9	Bolt	4	
10	Upper handlebar holder	2	
11	Handlebar assembly	1	
12	Lower handlebar holder	2	

EXPLODED DIAGRAM

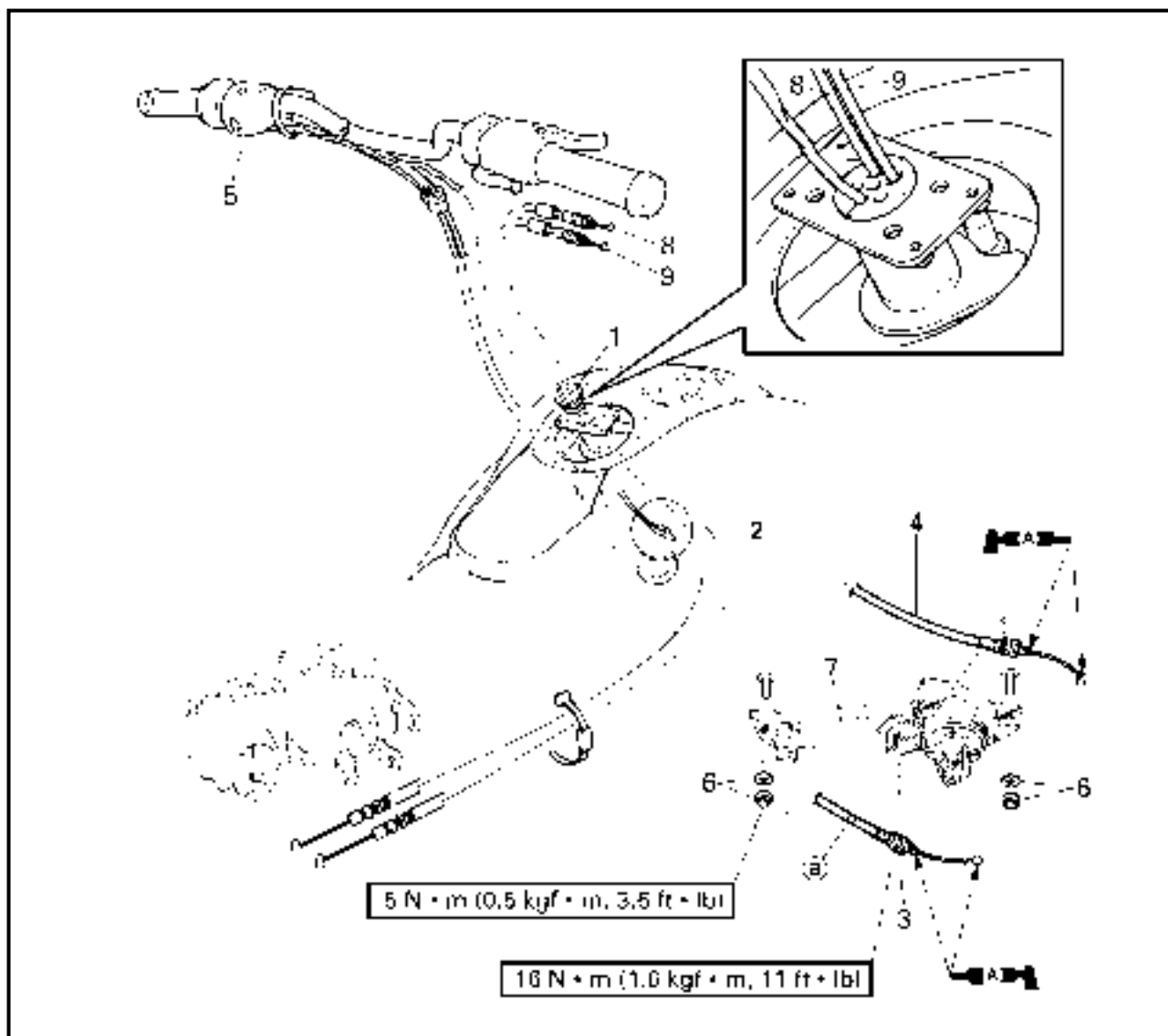

REMOVAL AND INSTALLATION CHART

Step	Procedure/Part name	Q'ty	Service points
	HANDLEBAR REMOVAL		
	QSTS cable (to jet nozzle)		Follow the left "Step" for removal. Refer to "REMOTE CONTROL CABLES AND SPEED SENSOR LEAD".
1	Grommet	1	NOTE: _____ Apply soapy water to the grommet for easier installation.
2	Handlebar switch coupler	2	
3	QSTS cable 2	1	with white tape @

EXPLODED DIAGRAM

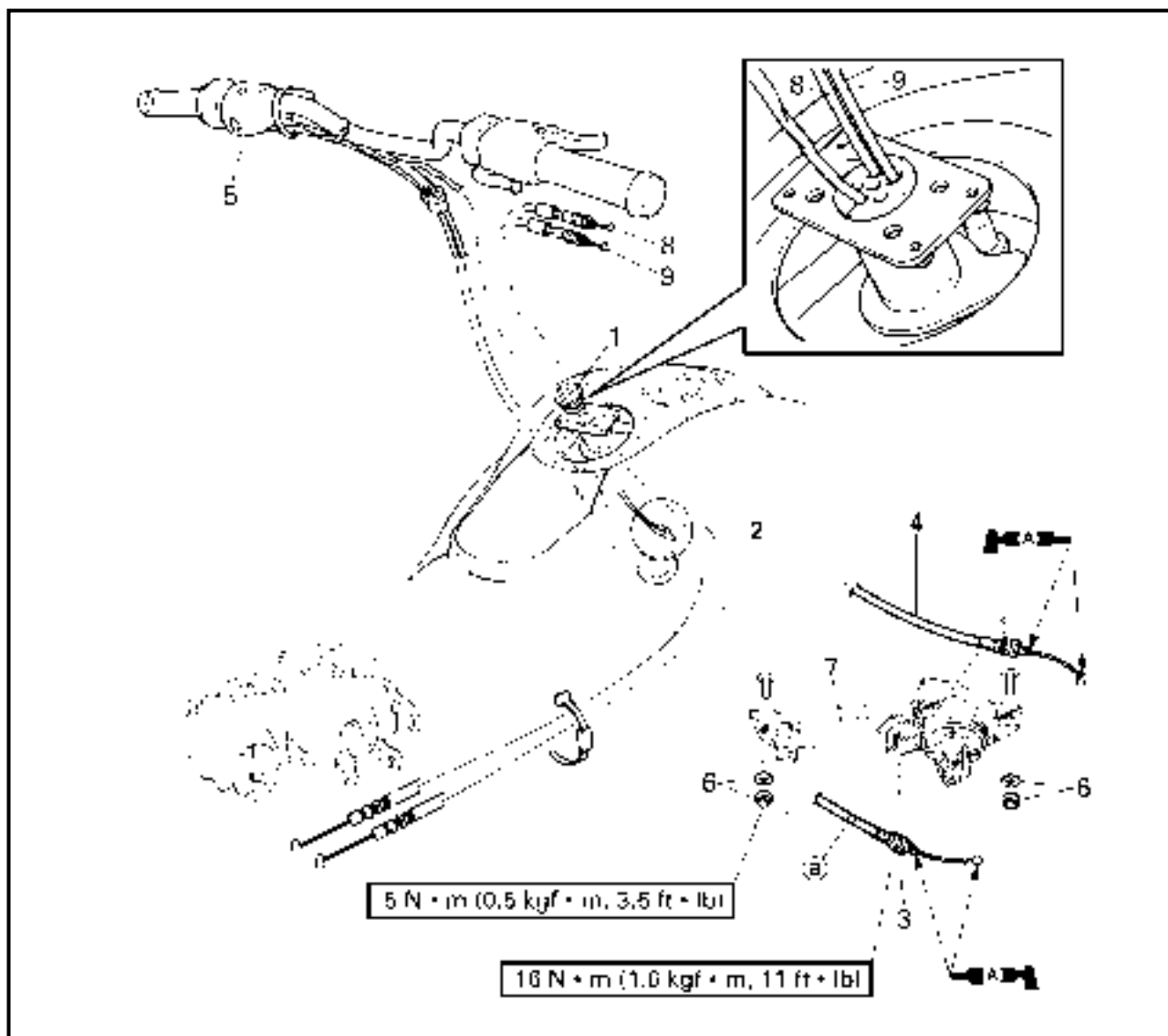

Step	Procedure/Part name	Q'ty	Service points
4	QSTS cable 1	1	NOTE: _____ Route the QSTS cables behind of the oil filler hose.
5	Handlebar assembly	1	
6	Nut/washer	2/2	
7	QSTS converter	1	
8	Throttle cable	1	
9	Choke cable	1	
			Reverse the removal steps for installation.

EXPLODED DIAGRAM

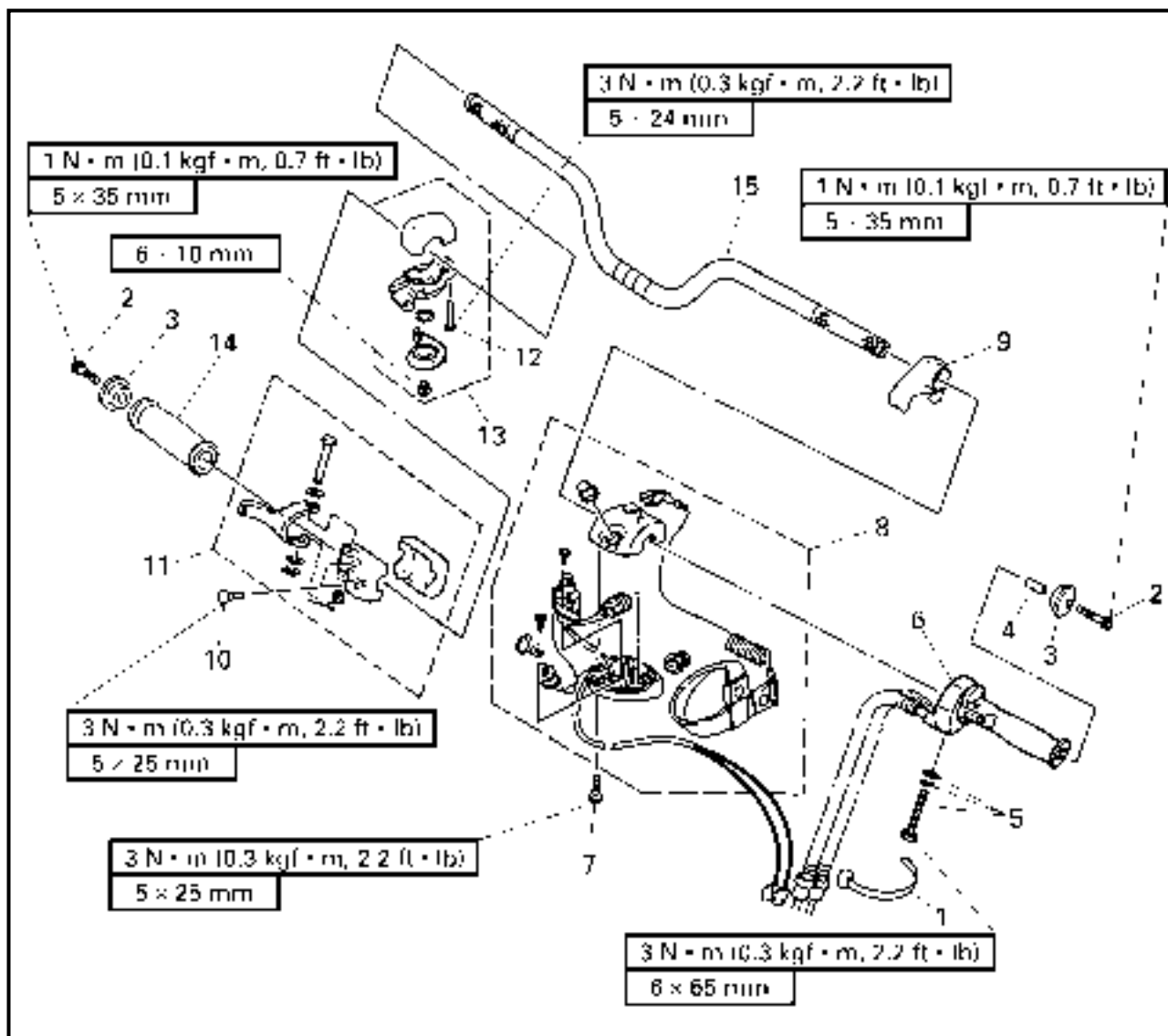

REMOVAL AND INSTALLATION CHART

Step	Procedure/Part name	Q'ty	Service points
	HANDLEBAR DISASSEMBLY		Follow the left "Step" for disassembly.
1	Band	1	
2	Bolt	2	
3	Grip end	2	
4	Spacer	1	
5	Screw/washer/spring washer	1/1/1	
6	OSTS grip assembly	1	
7	Screw	2	
8	Handlebar switch assembly	1	
9	Cable holder	1	

EXPLODED DIAGRAM

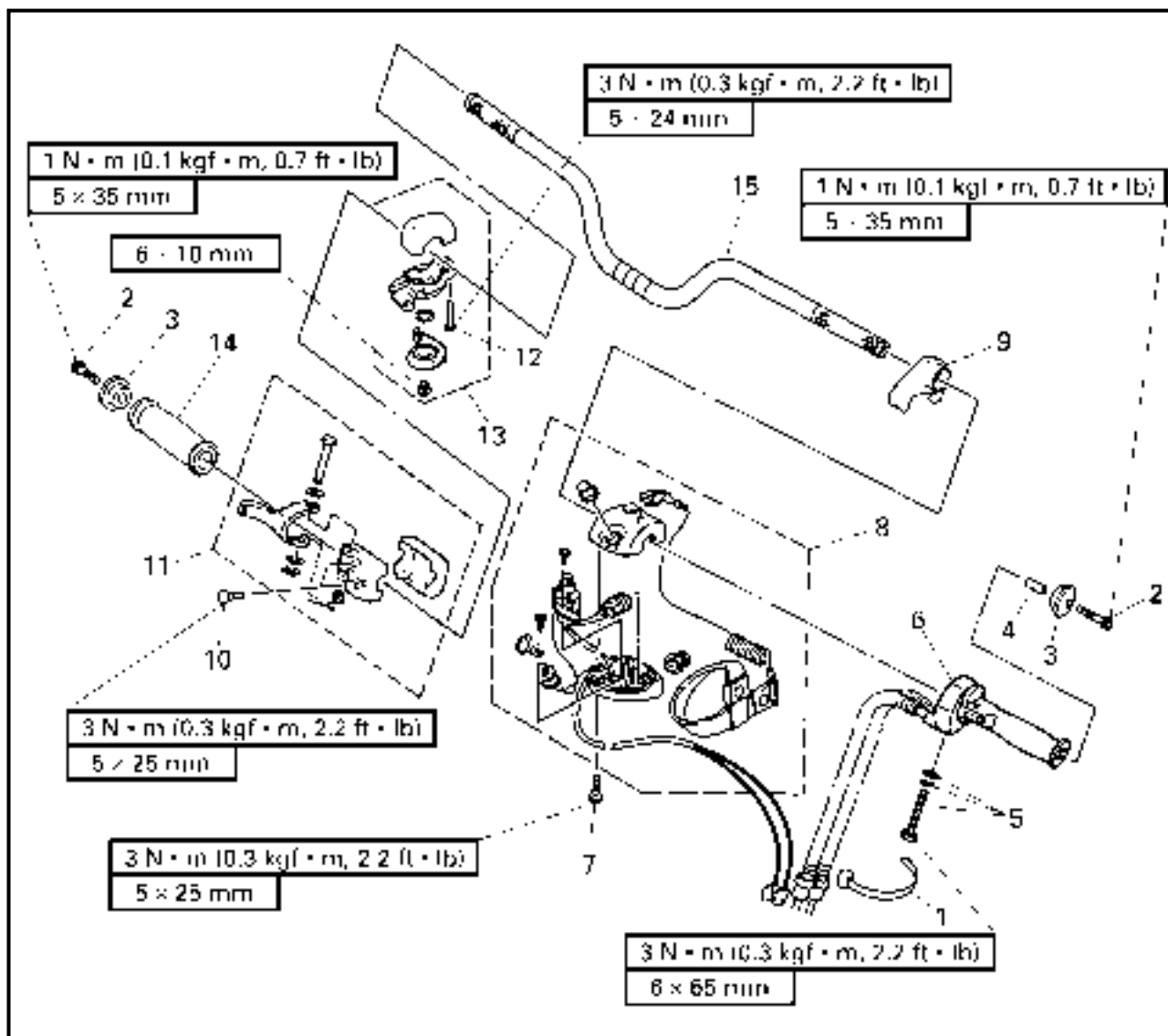

Step	Procedure/Part name	Q'ty	Service points
10	Screw	2	<p>NOTE: _____ Apply adhesive to the handlebar and the inner surface of the handlebar grip.</p>
11	Throttle lever assembly	1	
12	Screw	2	
13	Choke lever assembly	1	
14	Handlebar grip	1	
15	Handlebar	1	Reverse the disassembly steps for assembly.

SERVICE POINTS

Handlebar inspection

1. Inspect:
 - Handlebar
Bends/cracks/damage → Replace.

Handlebar switch inspection

Refer to "IGNITION SYSTEM" and "STARTING SYSTEM" in chapter 7.

Handlebar assembly installation

1. Adjust:
 - QSTS cable length ①

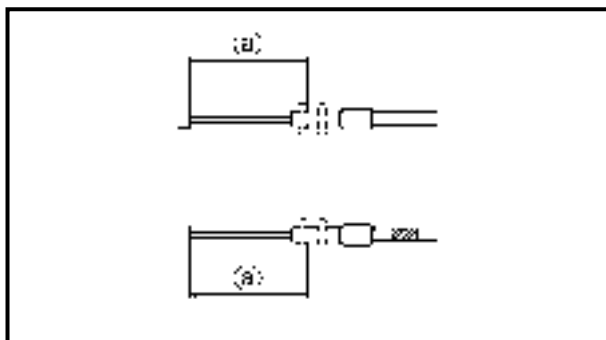

QSTS cable length:
77 ± 0.5 mm (3.03 ± 0.02 in)

NOTE: _____

- Before adjusting the QSTS cables, set the control grip to the neutral position.
- Adjust the QSTS cable lengths ① to the specified length and be sure to take up any slack.

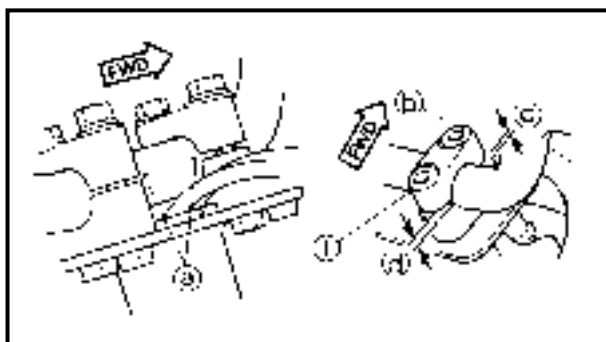

2. Install:
 - Upper handlebar holder ①

NOTE: _____

- Align the punch marks ① on the handlebar with the top surface of the handlebar holder.
- The upper handlebar holder should be installed with the punch mark ② facing forward.

CAUTION: _____

Clearance ③ should be narrower than clearance ④.

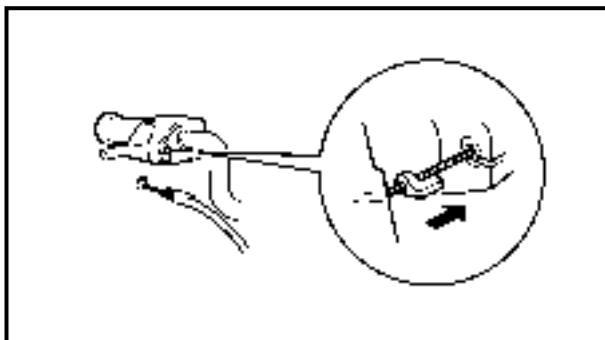

3. Install:
- Throttle cable

NOTE: _____
Fit the seal into the groove in the bracket.

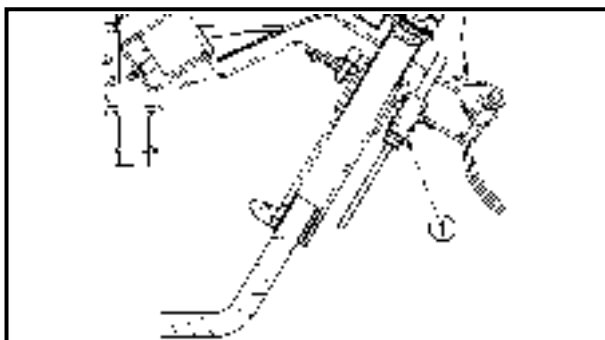

4. Install:
- Band ①

NOTE: _____
After inserting the QSTS cables into the grommet, tie the end of grommet with the band.

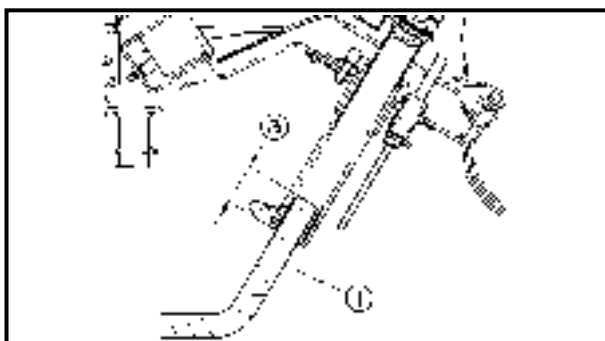

5. Install:
- Spiral tube ①

NOTE: _____
Be sure to install the spiral tube, containing the throttle cable, choke cable and handlebar switch lead, at least 50 mm (1.97 in) ② into the steering column.

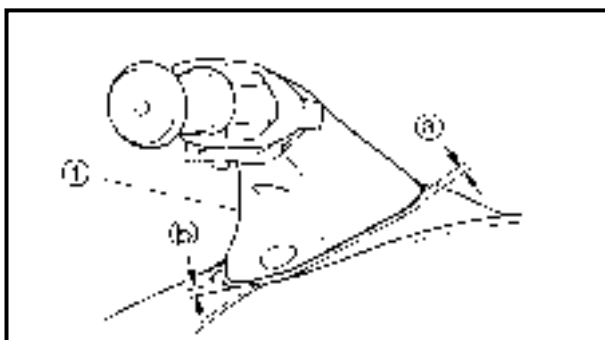

6. Install:
- Handlebar cover ①

NOTE: _____
When the handlebar cover is in contact with the steering console cover, adjust the handlebar mount angle so that the clearance ② and ③ are equal.



7. Adjust:
 - Choke lever operation
Refer to "CONTROL SYSTEM" in chapter 3.
8. Adjust:
 - Throttle lever free play
Refer to "CONTROL SYSTEM" in chapter 3.
9. Adjust:
 - QSTS cable
Refer to "CONTROL SYSTEM" in chapter 3.

**QSTS GRIP
EXPLODED DIAGRAM**

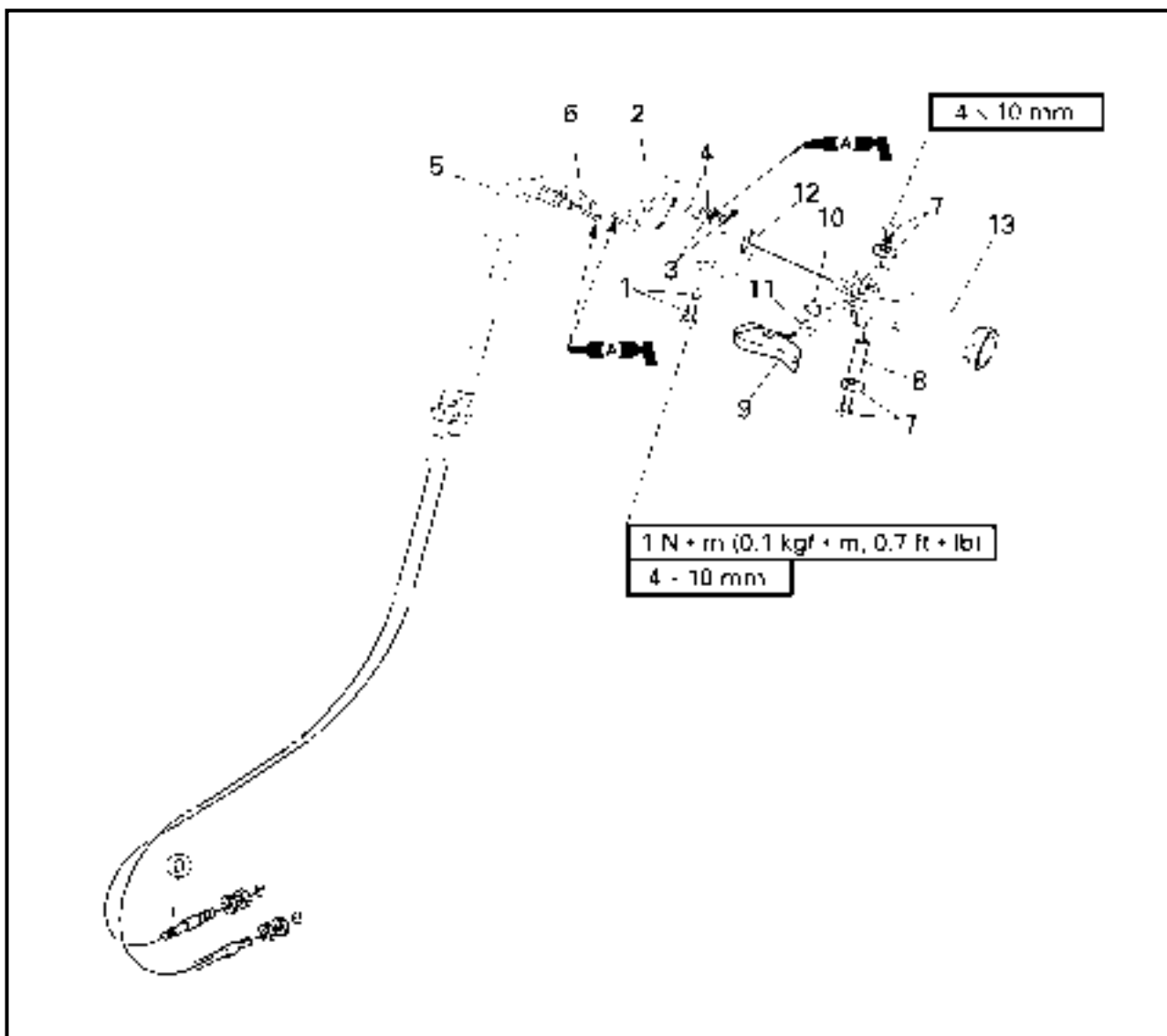

REMOVAL AND INSTALLATION CHART

Step	Procedure/Part name	Q'ty	Service points
	QSTS GRIP DISASSEMBLY		
	QSTS grip assembly		Follow the left "Step" for disassembly. Refer to "HANDLEBAR".
1	Screw/washer	1/1	
2	Cover	1	
3	Ball	2	
4	Spring	2	
5	QSTS cable 1	1	
6	QSTS cable 2	1	with white tape @

EXPLODED DIAGRAM

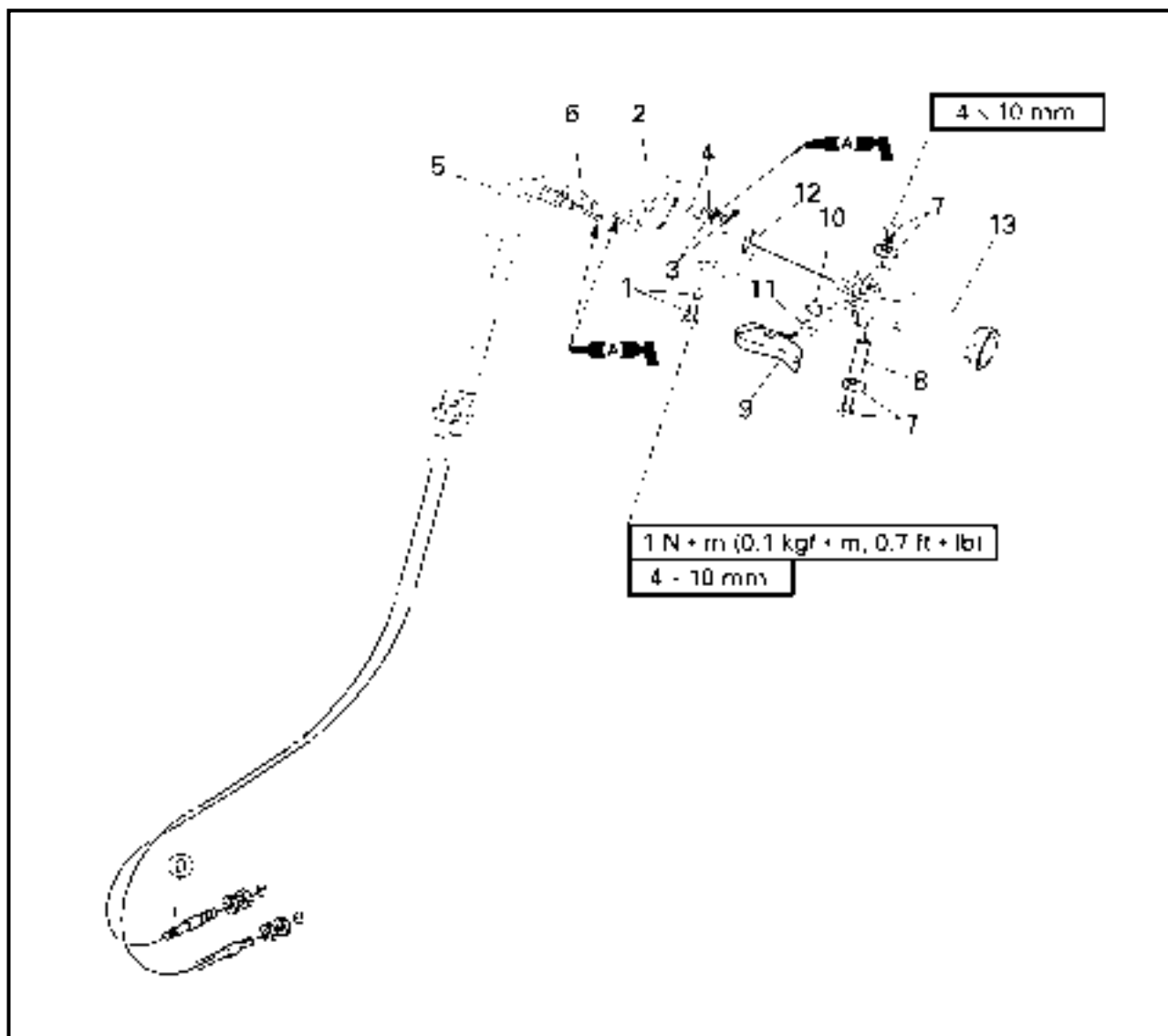

Step	Procedure/Part name	Q'ty	Service points
7	Screw/washer	2/2	Reverse the disassembly steps for assembly.
8	Collar	1	
9	QSTS shift lock lever	1	
10	Spring	1	
11	Spacer	1	
12	QSTS cable housing cover	1	
13	QSTS shift grip	1	



SERVICE POINTS

QSTS cable inspection

1. Inspect:

- QSTS cables

Frays/kinks/rough movement →

Replace.

QSTS grip inspection

1. Inspect:

- QSTS grip

Damage/wear → Replace.

**STEERING COLUMN
EXPLODED DIAGRAM**

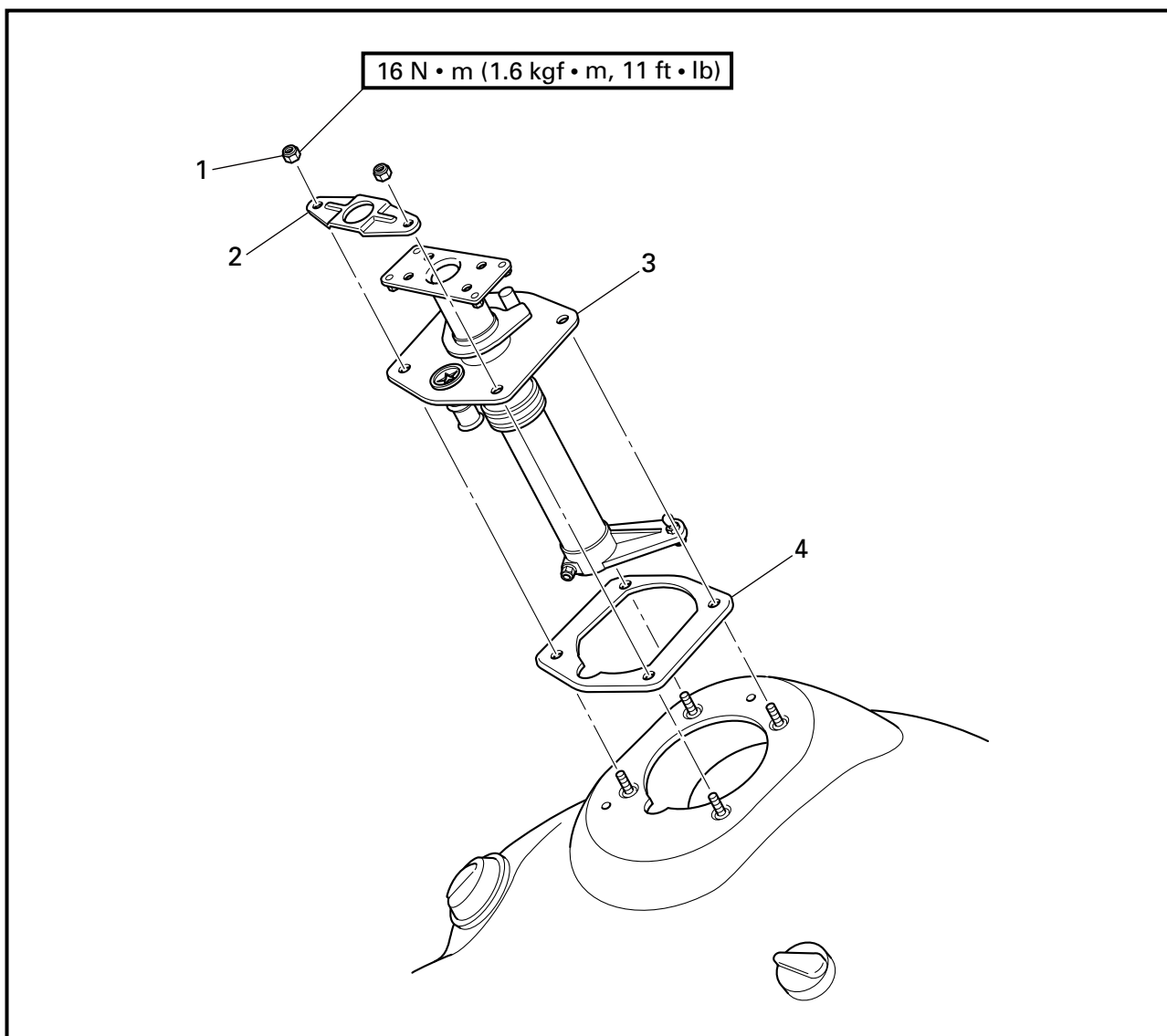

REMOVAL AND INSTALLATION CHART

Step	Procedure/Part name	Q'ty	Service points
	STEERING COLUMN REMOVAL Steering console cover assembly Steering cable end		Follow the left "Step" for removal. Refer to "STEERING CONSOLE COVER". Refer to "REMOTE CONTROL CABLES AND SPEED SENSOR LEAD".
1	Nut	4	
2	Plate	1	
3	Steering column assembly	1	
4	Rubber seal	1	
			Reverse the removal steps for installation.

EXPLODED DIAGRAM

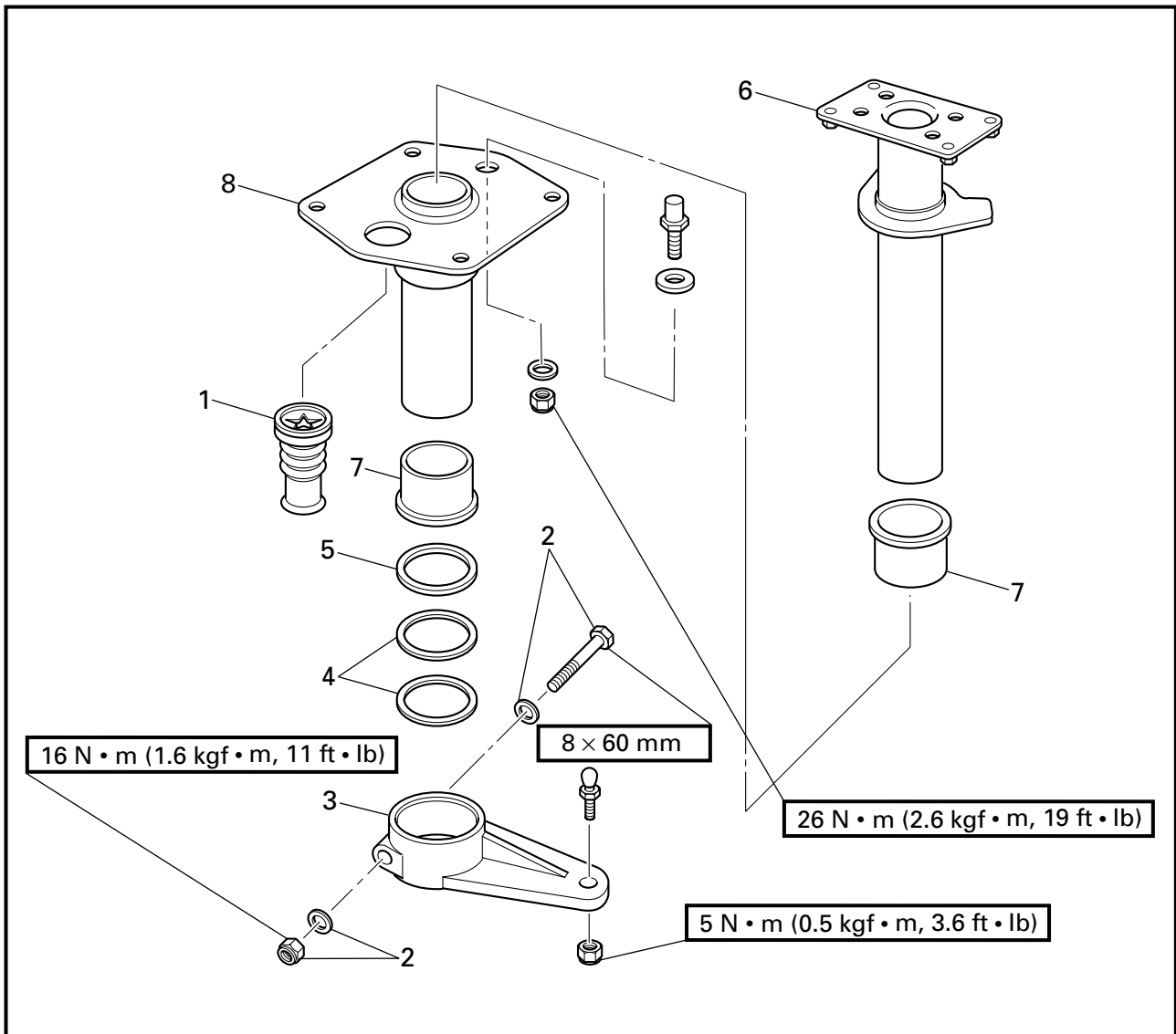

REMOVAL AND INSTALLATION CHART

Step	Procedure/Part name	Q'ty	Service points
	STEERING COLUMN DISASSEMBLY		Follow the left "Step" for disassembly.
1	Grommet	1	
2	Bolt/washer/nut	1/2/1	
3	Steering arm	1	
4	Shim	*	

*: Be sure to install the same number of shim(s) as installed originally at factory.

EXPLODED DIAGRAM

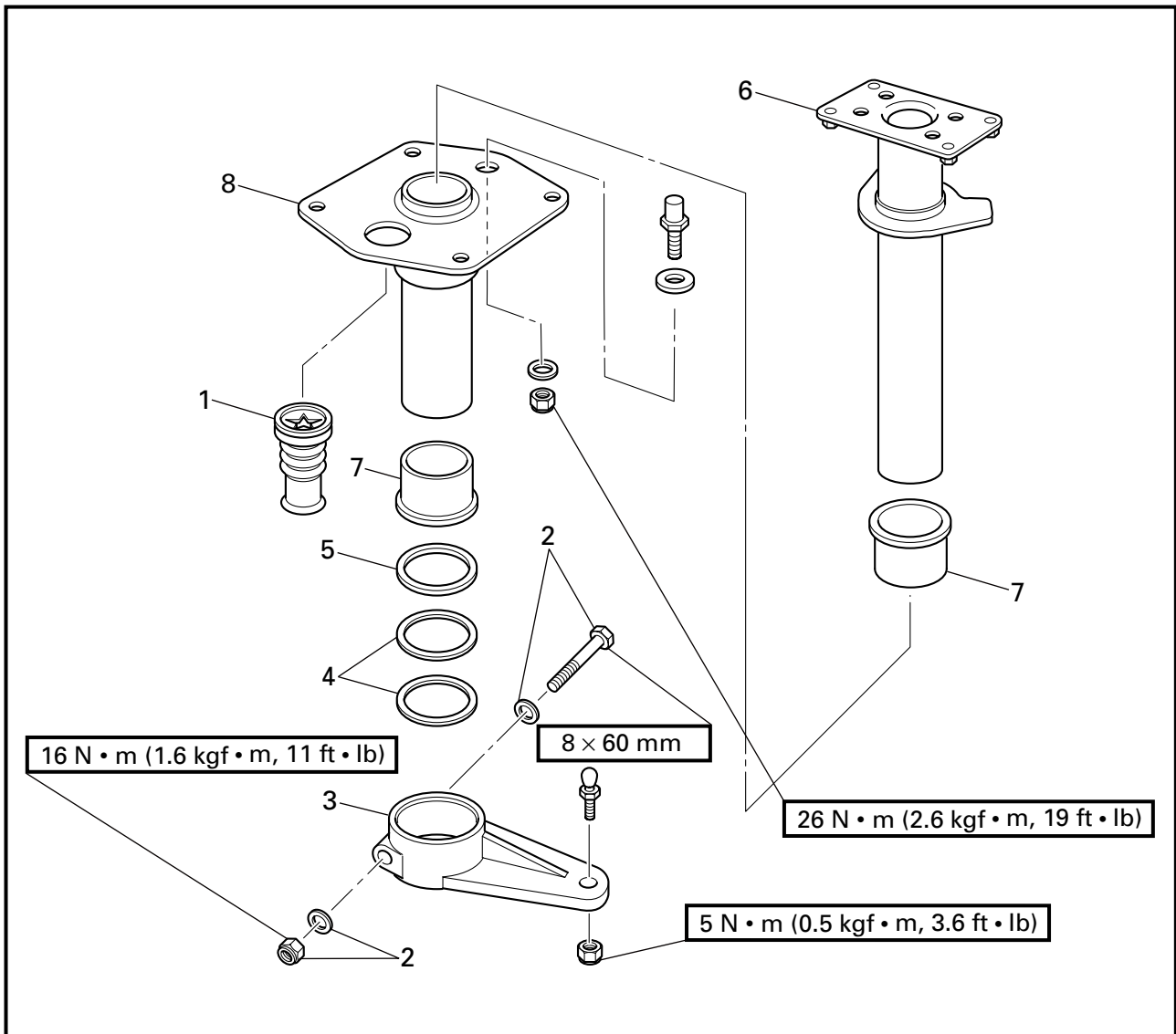

Step	Procedure/Part name	Q'ty	Service points
5	Washer	1	Reverse the disassembly steps for assembly.
6	Steering column	1	
7	Bushing	2	
8	Steering column housing	1	

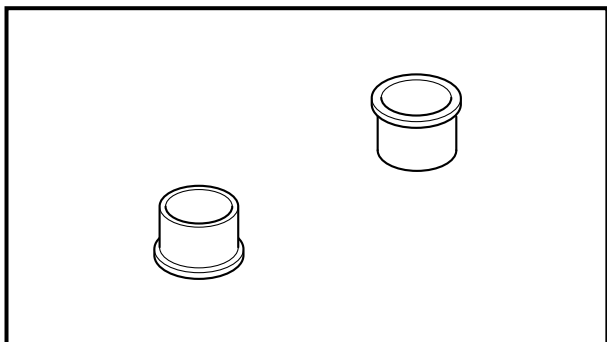

SERVICE POINTS

Steering column bushing inspection

1. Inspect:
 - Bushings
Damage/wear → Replace.
2. Inspect:
 - Steering column inspection
Refer to "CONTROL SYSTEM" in chapter 3.

REMOTE CONTROL CABLES AND SPEED SENSOR LEAD EXPLODED DIAGRAM

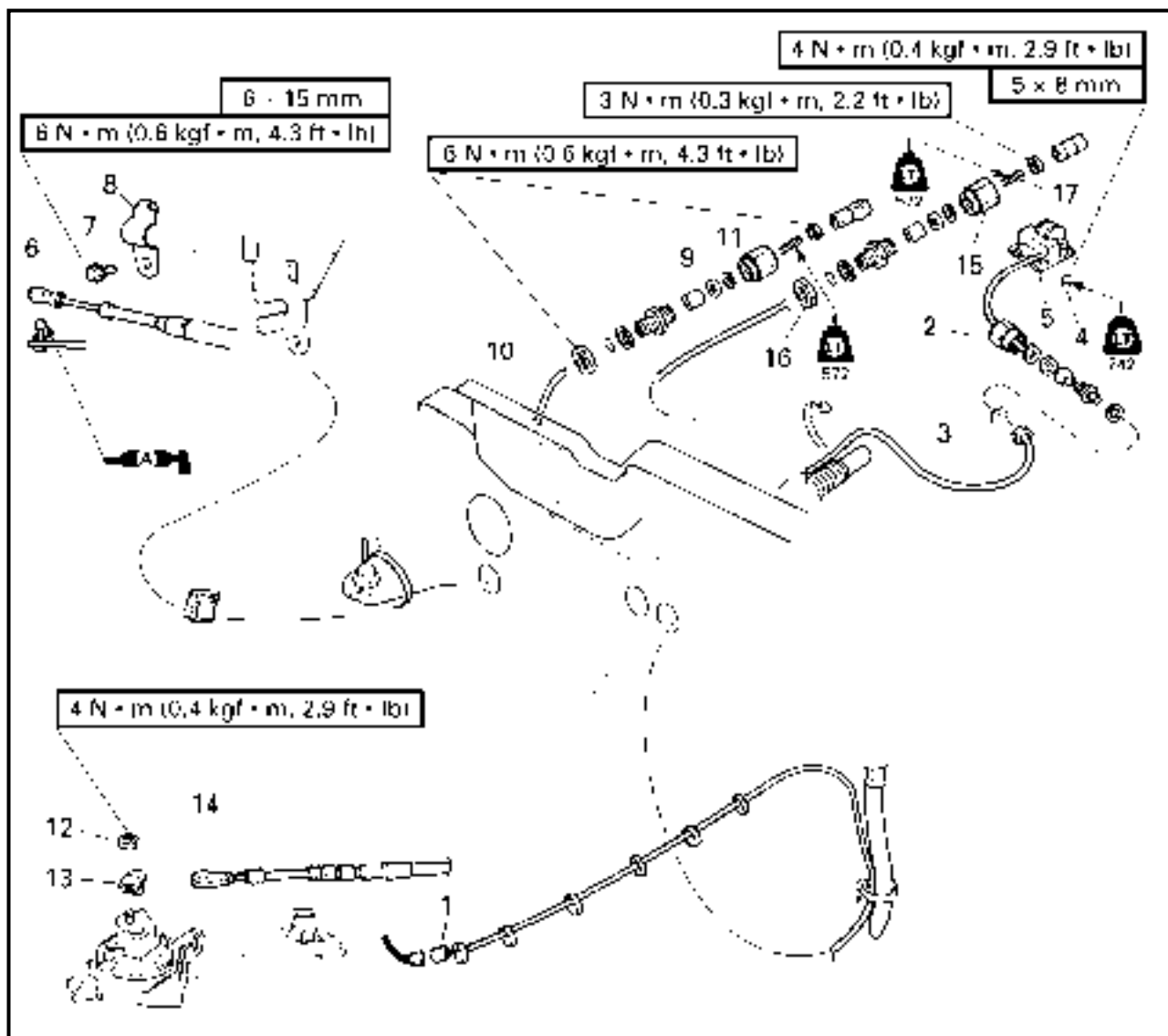

REMOVAL AND INSTALLATION CHART

Step	Procedure/Part name	Q'ty	Service points
	REMOTE CONTROL CABLES AND SPEED SENSOR LEAD REMOVAL		Follow the left "Step" for removal.
1	Speed sensor coupler	1	
2	Cap	1	
3	Nut	1	
4	Screw	4	
5	Speed sensor	1	
6	Steering cable end	1	
7	Bolt	1	
8	Steering cable holder	1	

EXPLODED DIAGRAM

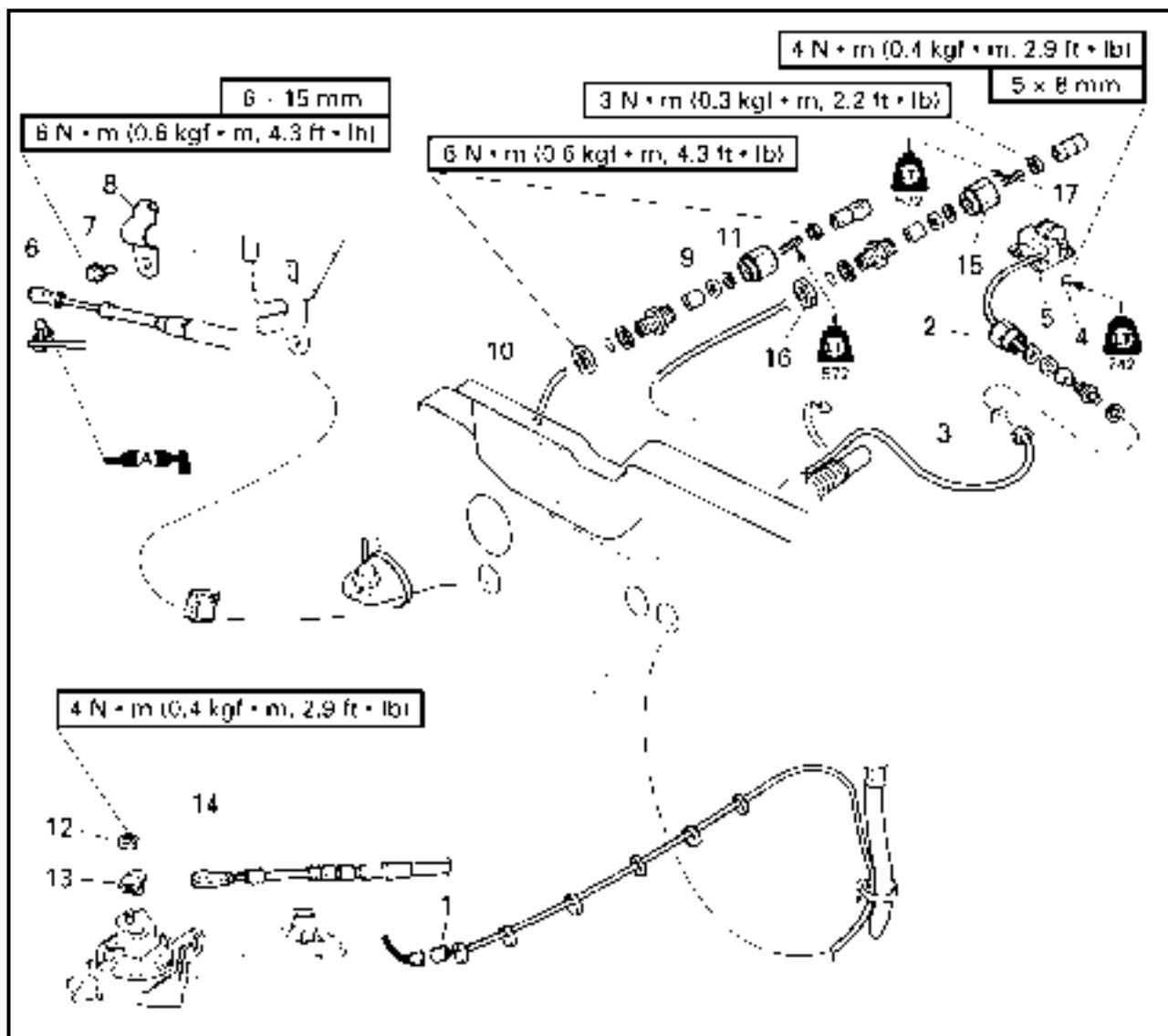

Step	Procedure/Part name	Q'ty	Service points
9	Cap	1	Reverse the removal steps for installation.
10	Nut	1	
11	Steering cable	1	
12	Nut	1	
13	Pin	1	
14	QSTS cable end	1	
15	Cap	1	
16	Nut	1	
17	QSTS cable	1	

EXPLODED DIAGRAM

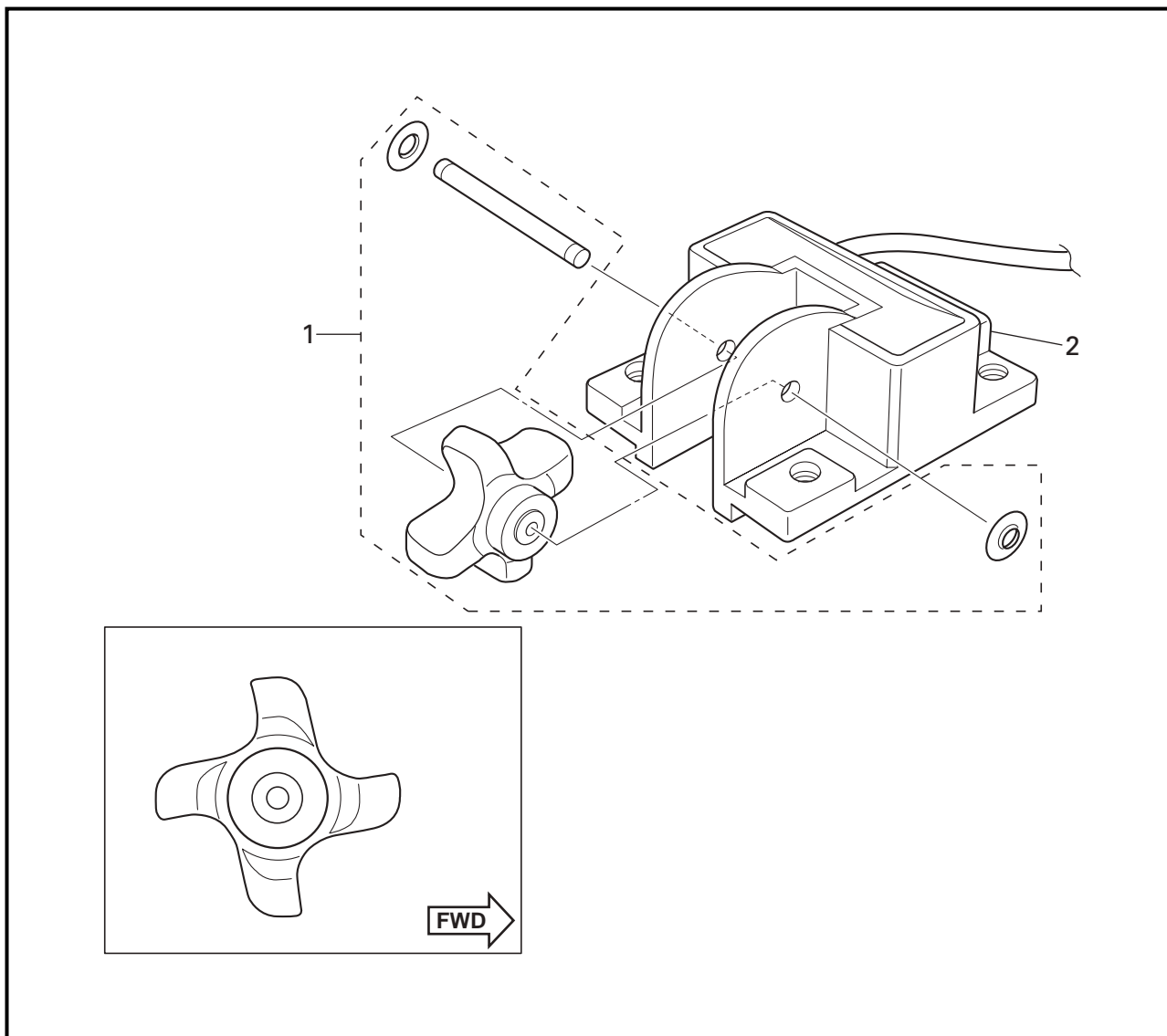

REMOVAL AND INSTALLATION CHART

Step	Procedure/Part name	Q'ty	Service points
SPEED SENSOR DISASSEMBLY			
1	Paddle wheel set	1	Follow the left "Step" for disassembly. Not reusable
2	Speed sensor housing	1	
			Reverse the disassembly steps for assembly.

SERVICE POINTS

⚠ WARNING

When routing the cables, do not grasp the cable by the outer crimped sheath or steel end. This could deform or loosen the cable end due to extreme angles and or pressure. Always hold the cables by the bracket or outer cover below the crimp. If a cable becomes damaged replace it. Never attempt to repair a damaged cable.

Remote control cables inspection

1. Inspect:
 - Steering cable
 - QSTS cable
 Frays/kinks/rough movement → Replace.

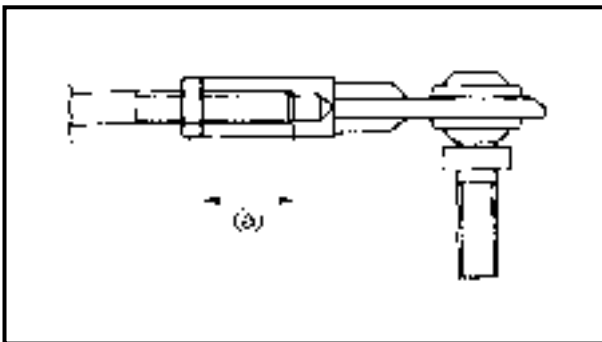

Steering cable (jet pump side) installation

1. Install:
 - Steering cable **a**



Steering cable set length (jet pump side):
13.5–15.5 mm (0.53–0.61 in)

⚠ WARNING

The steering cable must be screwed in at least 8 mm (0.31 in).

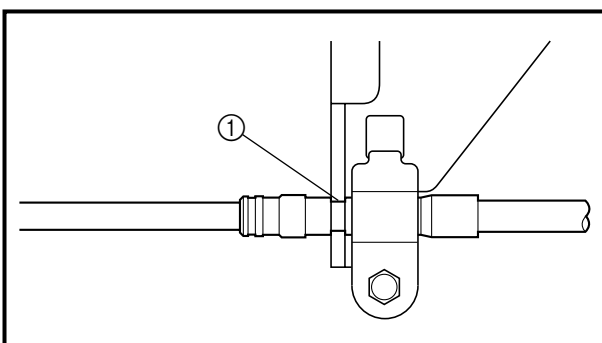

Steering cable stopper installation

1. Install:
 - Steering cable stopper

⚠ WARNING

Be sure to fit the steering cable into the glove **1** in the steering cable bracket.

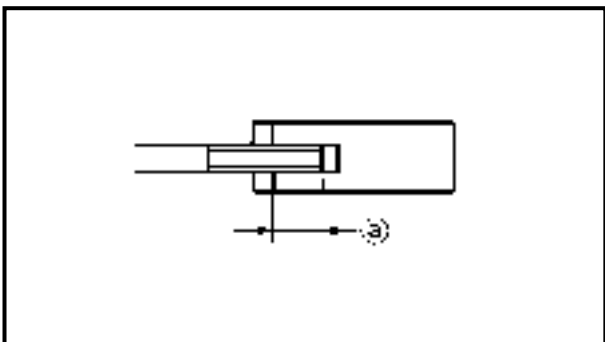

QSTS cable (jet pump side) installation

1. Install:
 - QSTS cable (jet pump side) ②



QSTS cable set length (jet pump side):
12.0–14.0 mm (0.47–0.55 in)

⚠ WARNING

The QSTS cable must be screwed in more than 8 mm (0.31 in).

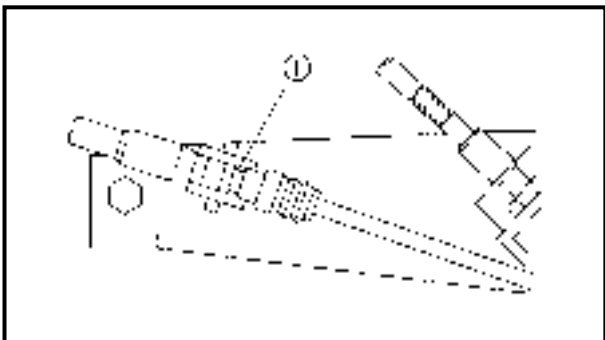

QSTS cable stopper installation

1. Install:
 - QSTS cable stopper

⚠ WARNING

Be sure to fit the projection ① on the QSTS cable stopper into the groove in the outer cable.

**FRONT HOOD
EXPLODED DIAGRAM**

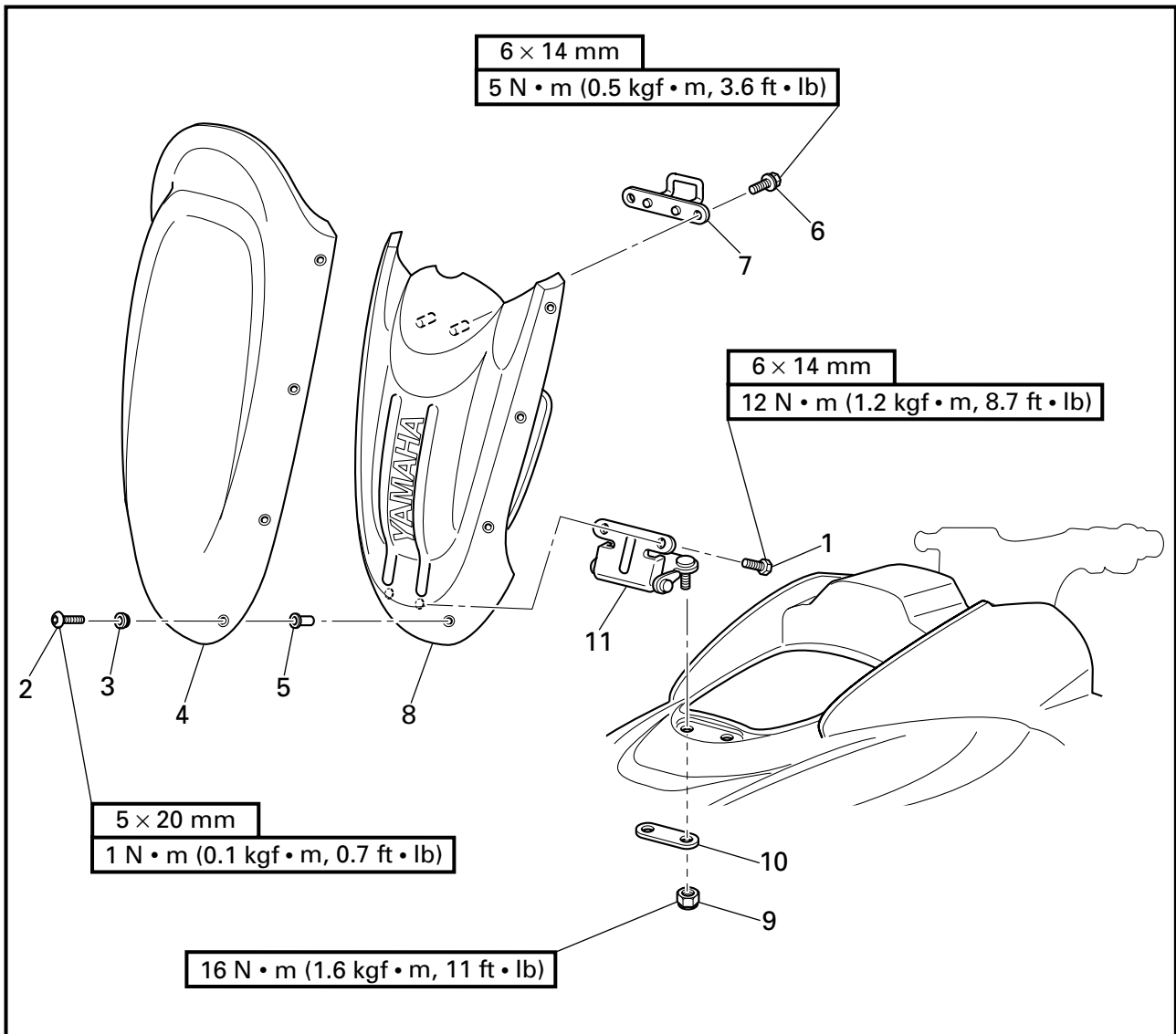

REMOVAL AND INSTALLATION CHART

Step	Procedure/Part name	Q'ty	Service points
	FRONT HOOD REMOVAL		Follow the left "Step" for removal.
1	Bolt	2	
2	Screw	8	
3	Seal washer	8	
4	Visor	1	
5	Pop nut	8	
6	Bolt	2	

EXPLODED DIAGRAM

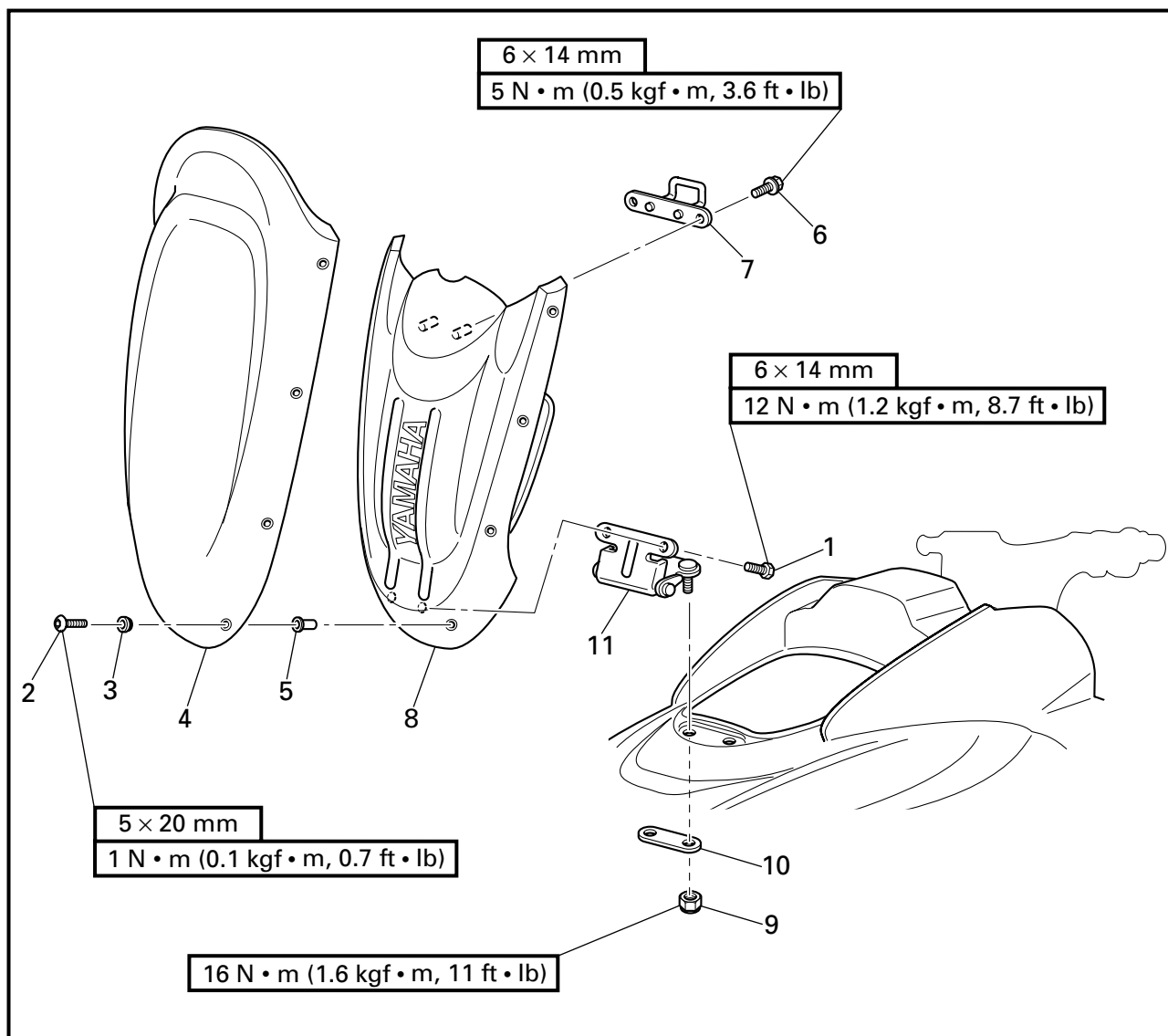

Step	Procedure/Part name	Q'ty	Service points
7	Hood lock	1	Reverse the removal steps for installation.
8	Front hood	1	
9	Nut	2	
10	Plate	1	
11	Hinge assembly	1	

**STEERING CONSOLE COVER
EXPLODED DIAGRAM**

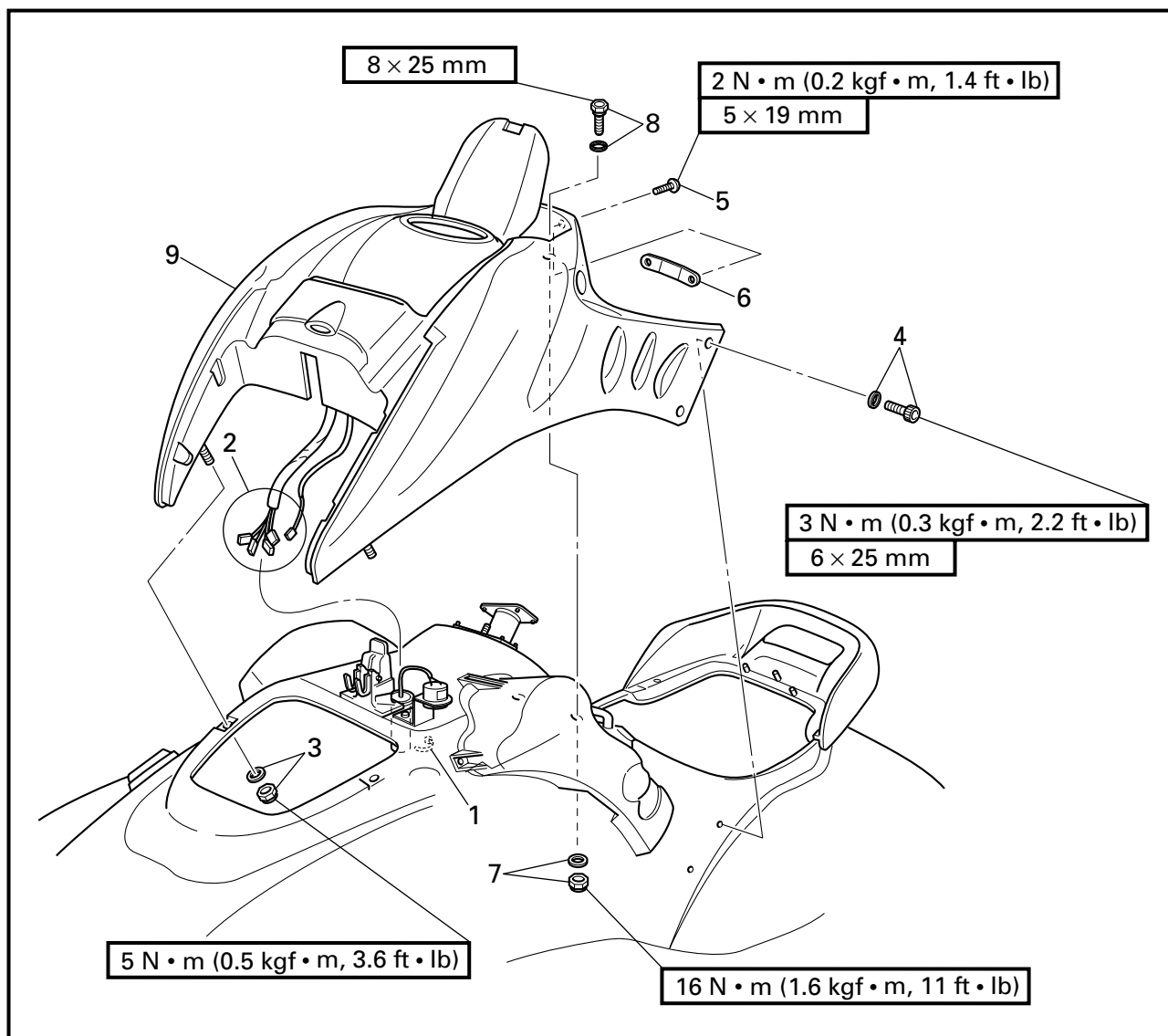

REMOVAL AND INSTALLATION CHART

Step	Procedure/Part name	Q'ty	Service points
	STEERING CONSOLE COVER REMOVAL		Follow the left "Step" for removal.
	Handlebar assembly		Refer to "HANDLEBAR".
	Knob (fuel cock)		Refer to "FUEL COCK AND FUEL FILTER" in chapter 4.
1	Band	1	
2	Multifunction meter coupler	5	
3	Nut/washer	2/2	
4	Bolt/washer	4/4	
5	Screw	2	

EXPLODED DIAGRAM

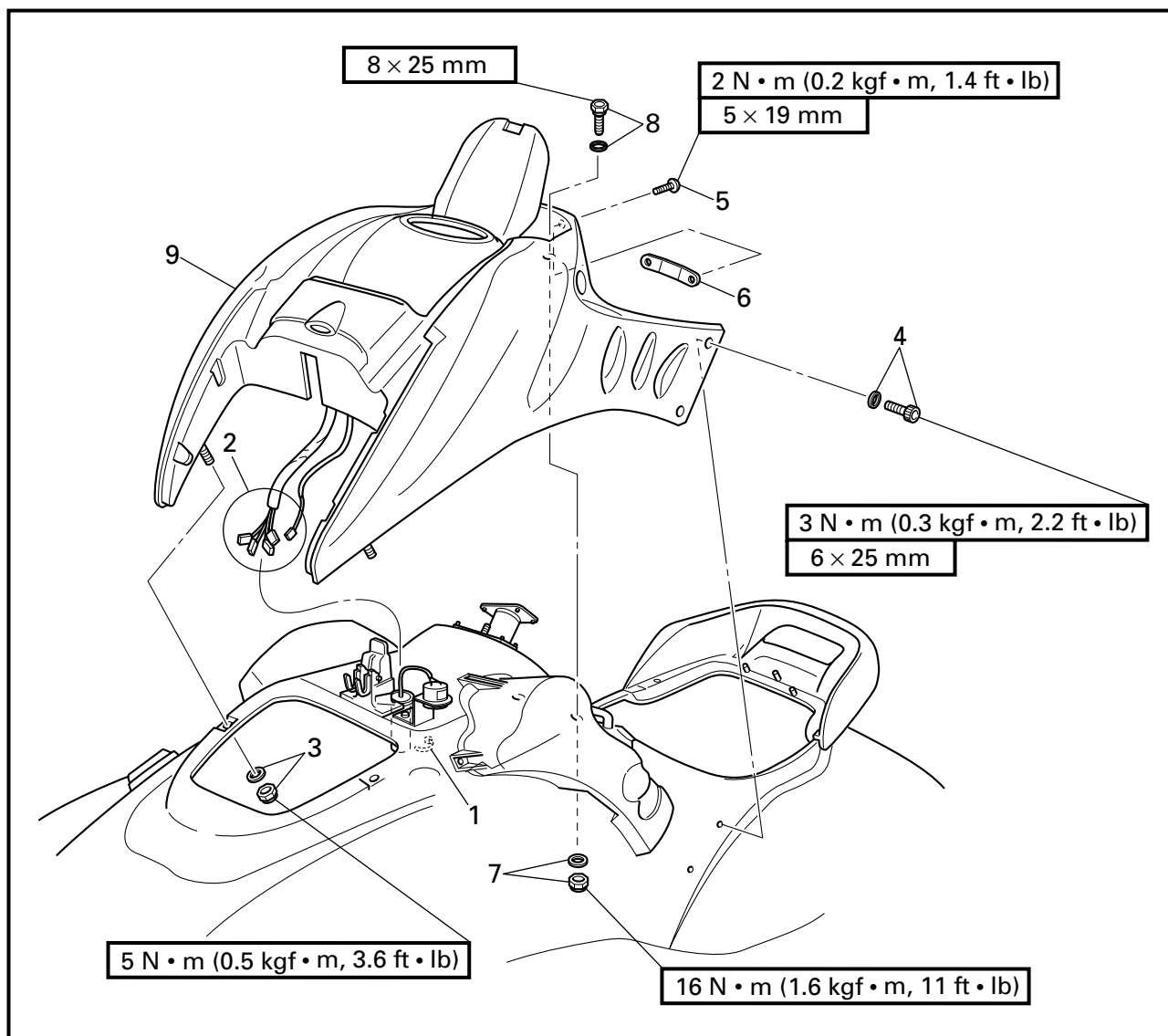

Step	Procedure/Part name	Q'ty	Service points
6	Plate	1	<p>NOTE: _____ Remove the oil filler cap to remove the steering console cover assembly easier. _____ Reverse the removal steps for installation.</p>
7	Nut/washer	2/2	
8	Bolt/square-ring	2/2	
9	Steering console cover assembly	1	

EXPLODED DIAGRAM

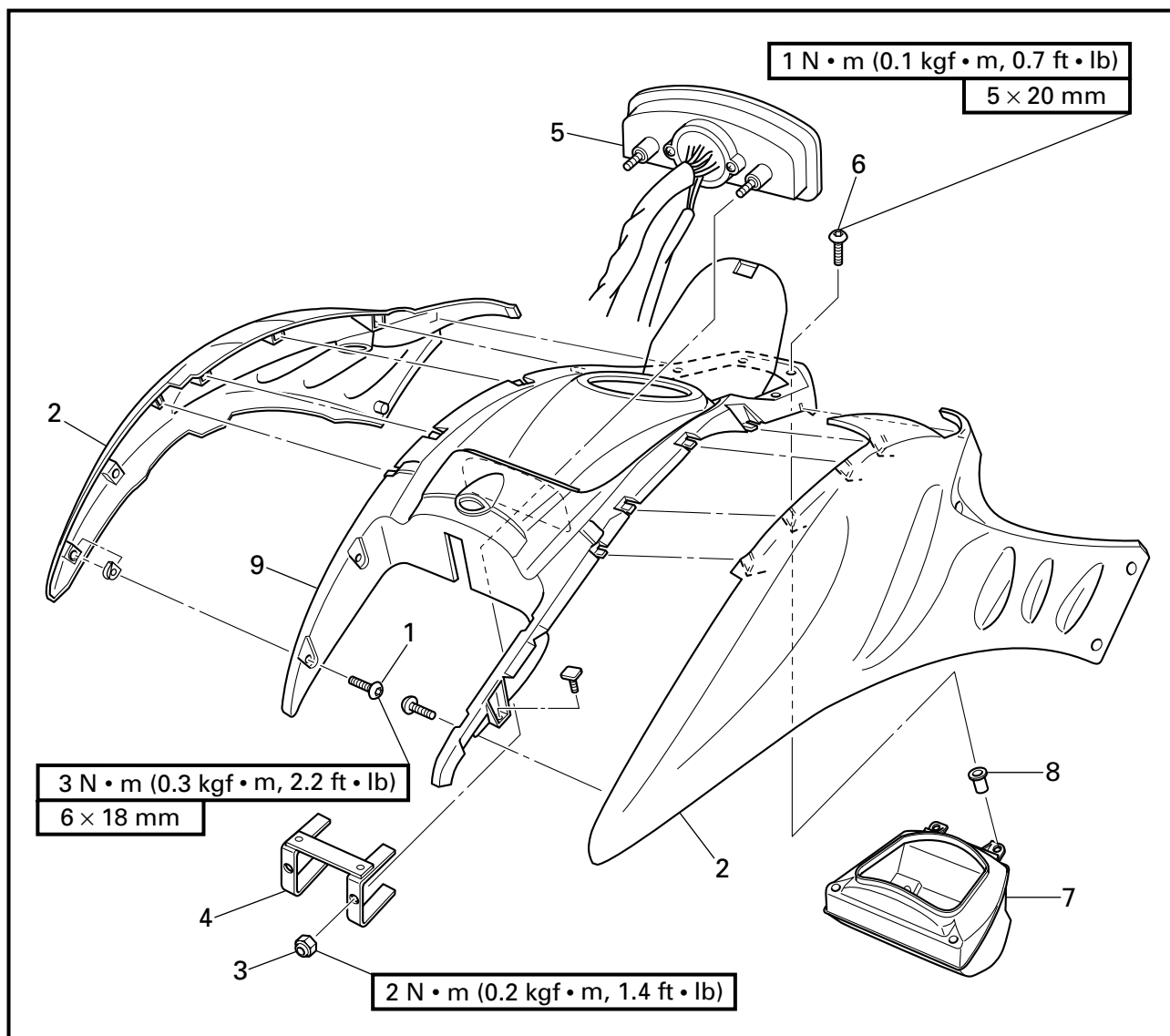

REMOVAL AND INSTALLATION CHART

Step	Procedure/Part name	Q'ty	Service points
	STEERING CONSOLE COVER DISASSEMBLY		Follow the left "Step" for disassembly.
1	Screw	4	
2	Side cover	2	
3	Nut	2	
4	Holder	1	
5	Multifunction meter	1	

EXPLODED DIAGRAM

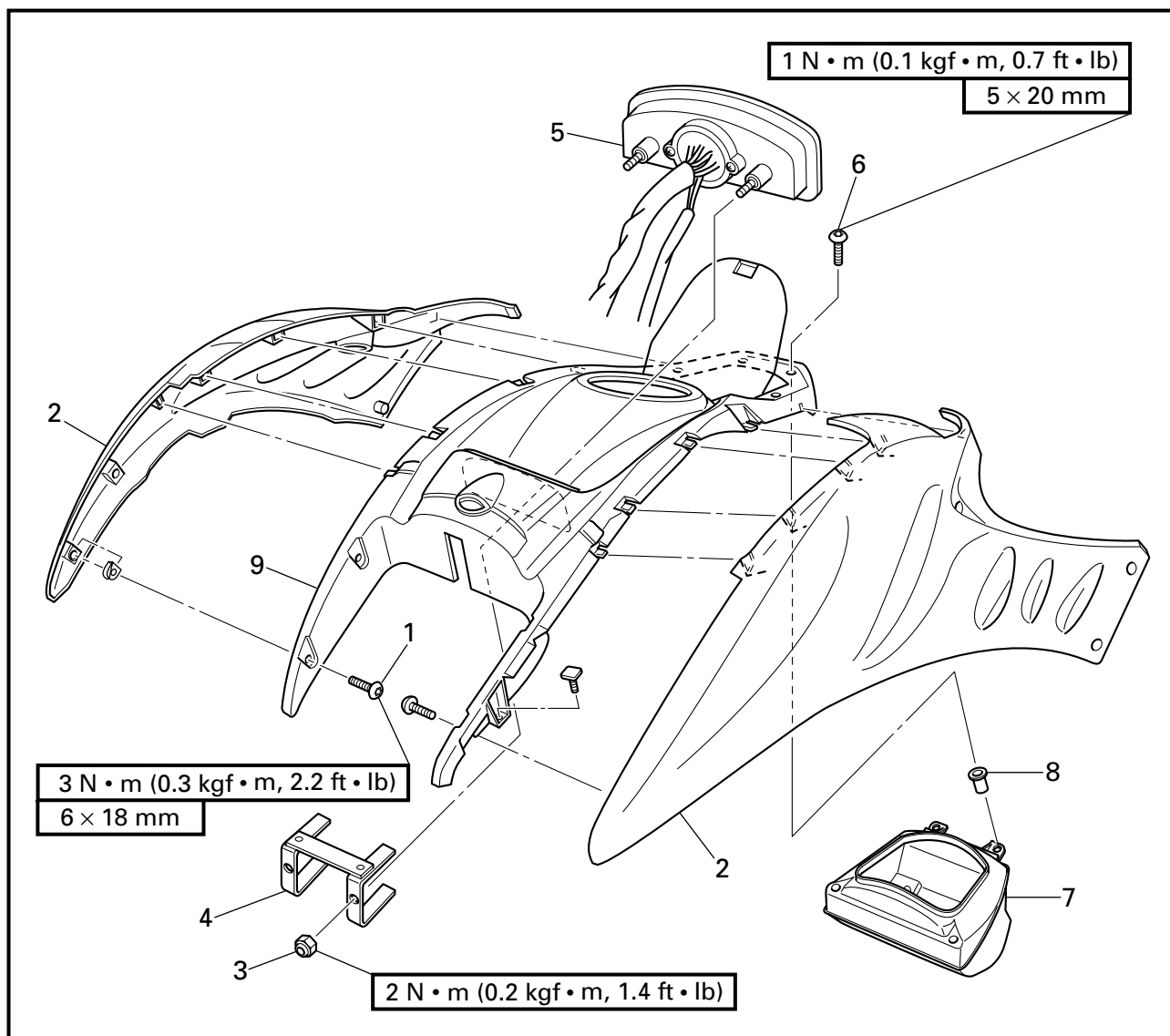

Step	Procedure/Part name	Q'ty	Service points
6	Screw	4	Reverse the disassembly steps for assembly.
7	Glove compartment	1	
8	Pop nut	4	
9	Steering console cover	1	

**BUZZER AND HOOD LOCK
EXPLODED DIAGRAM**

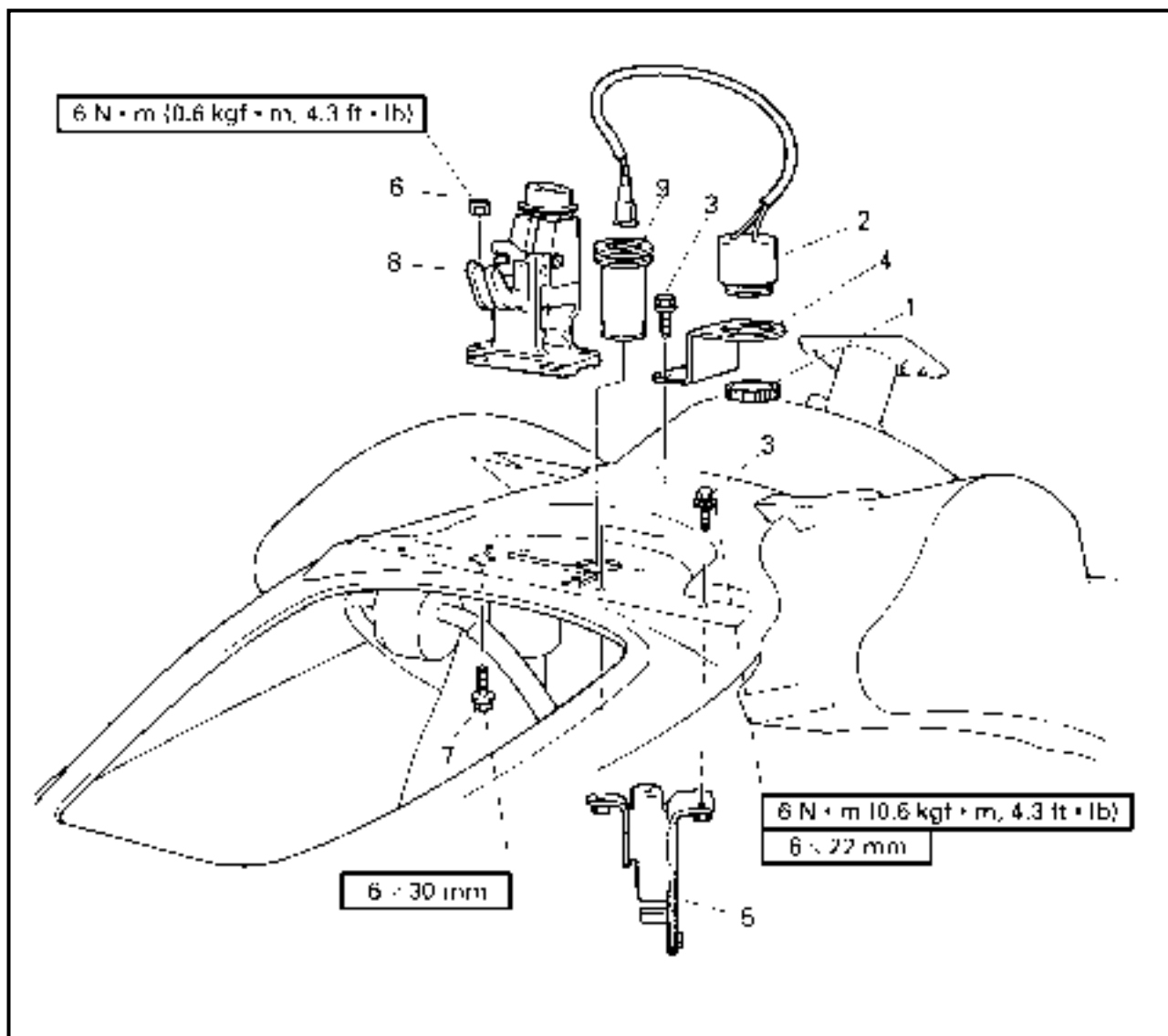

REMOVAL AND INSTALLATION CHART

Step	Procedure/Part name	Q'ty	Service points
	BUZZER AND HOOD LOCK REMOVAL		Follow the left "Step" for removal.
	Steering console cover assembly		Refer to "STEERING CONSOLE COVER".
	Steering cable		Refer to "REMOTE CONTROL CABLES AND SPEED SENSOR LEAD".
1	Ring nut	1	
2	Buzzer	1	
3	Bolt	3	
4	Bracket	1	
5	Bracket	1	

EXPLODED DIAGRAM

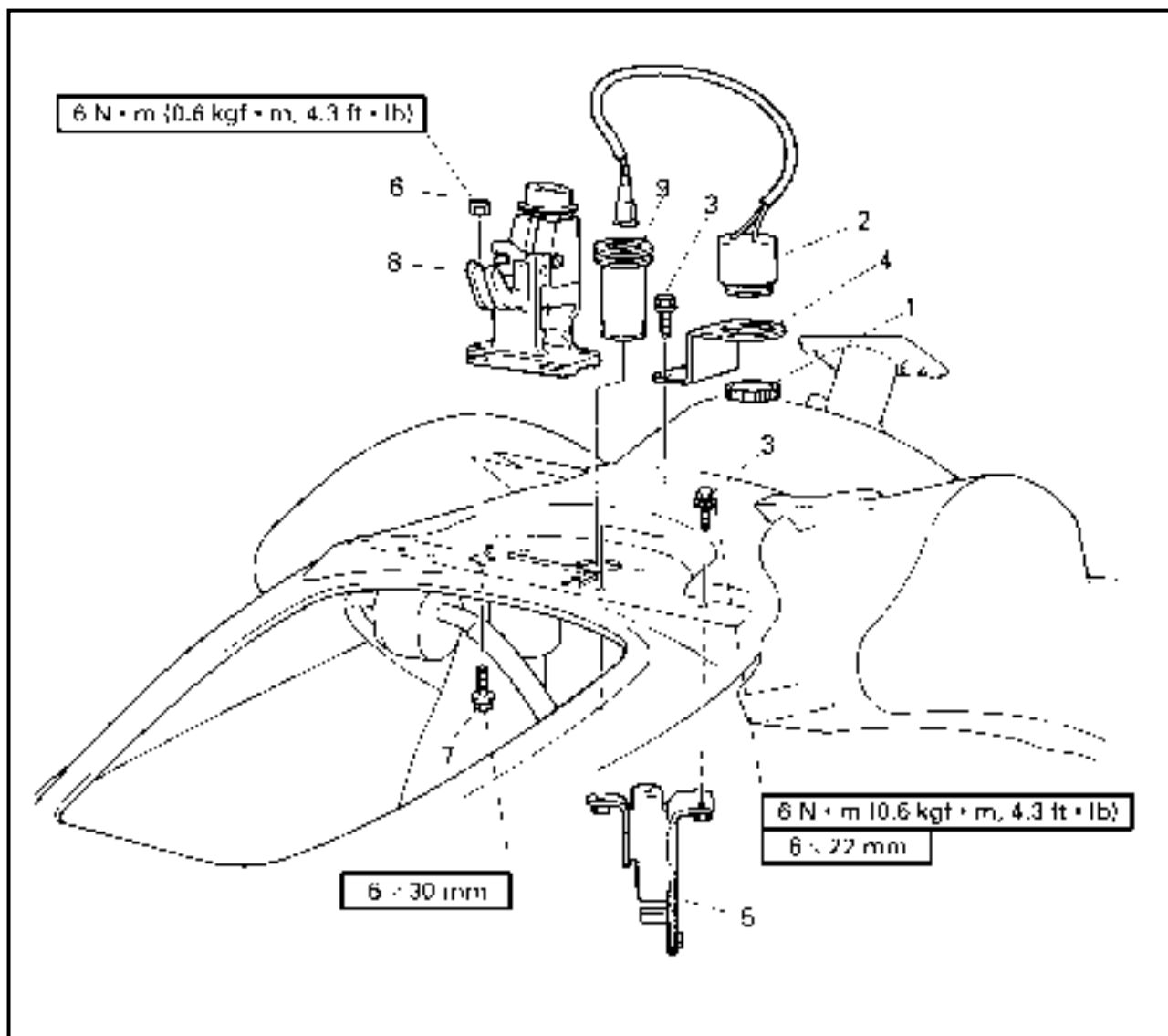

Step	Procedure/Part name	Q'ty	Service points
6	Nut	2	Reverse the removal steps for installation.
7	Bolt	2	
8	Hood lock assembly	1	
9	Grommet	1	

EXPLODED DIAGRAM

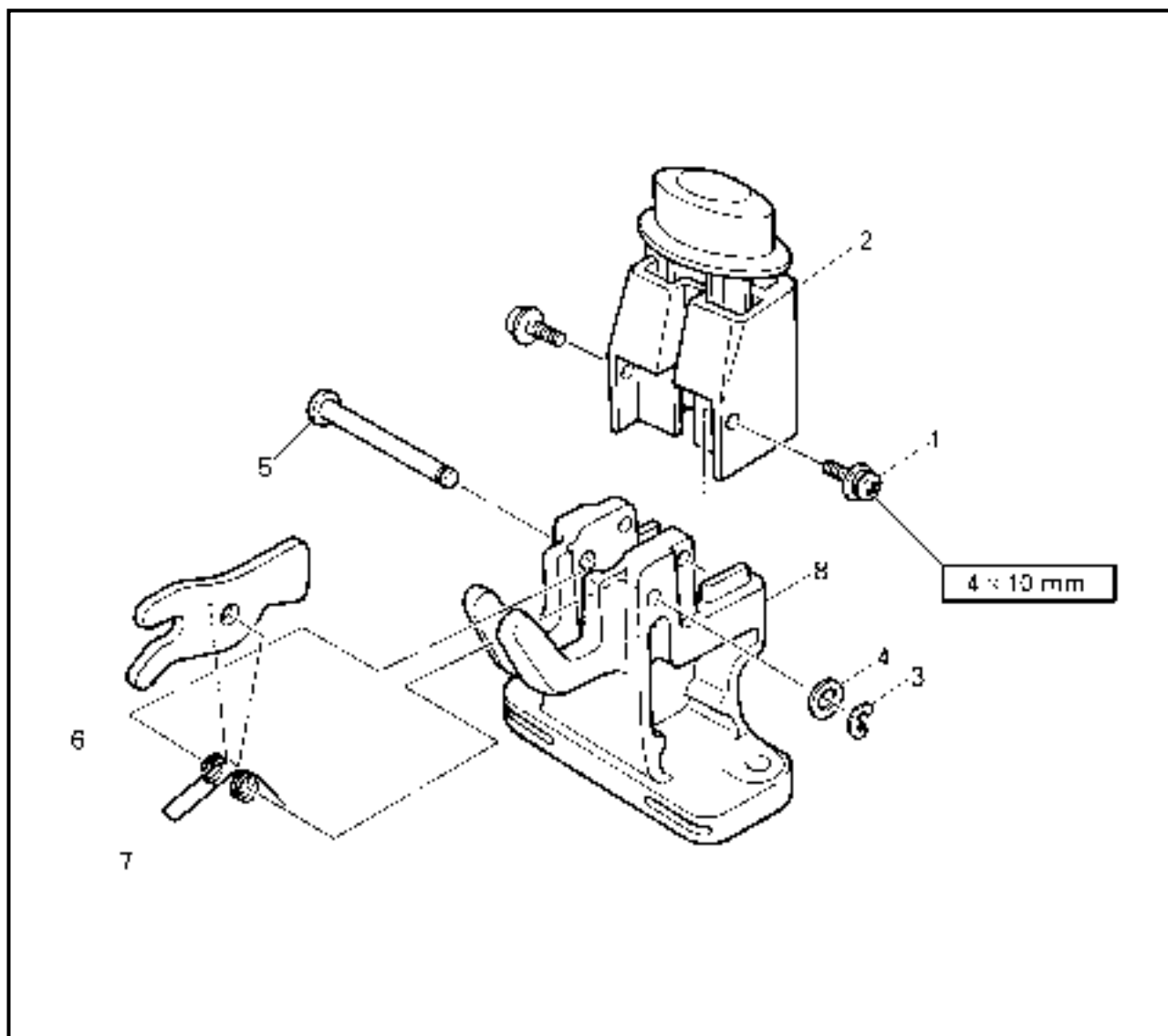

REMOVAL AND INSTALLATION CHART

Step	Procedure/Part name	Q'ty	Service points
	HOOD LOCK DISASSEMBLY		Follow the left "Step" for disassembly.
1	Screw	2	
2	Hood lock button assembly	1	
3	Circlip	1	
4	Washer	1	
5	Pin	1	
6	Hook lever	1	
7	Spring	1	
8	Hood lock body	1	
			Reverse the disassembly steps for assembly.

**HOSES
EXPLODED DIAGRAM**

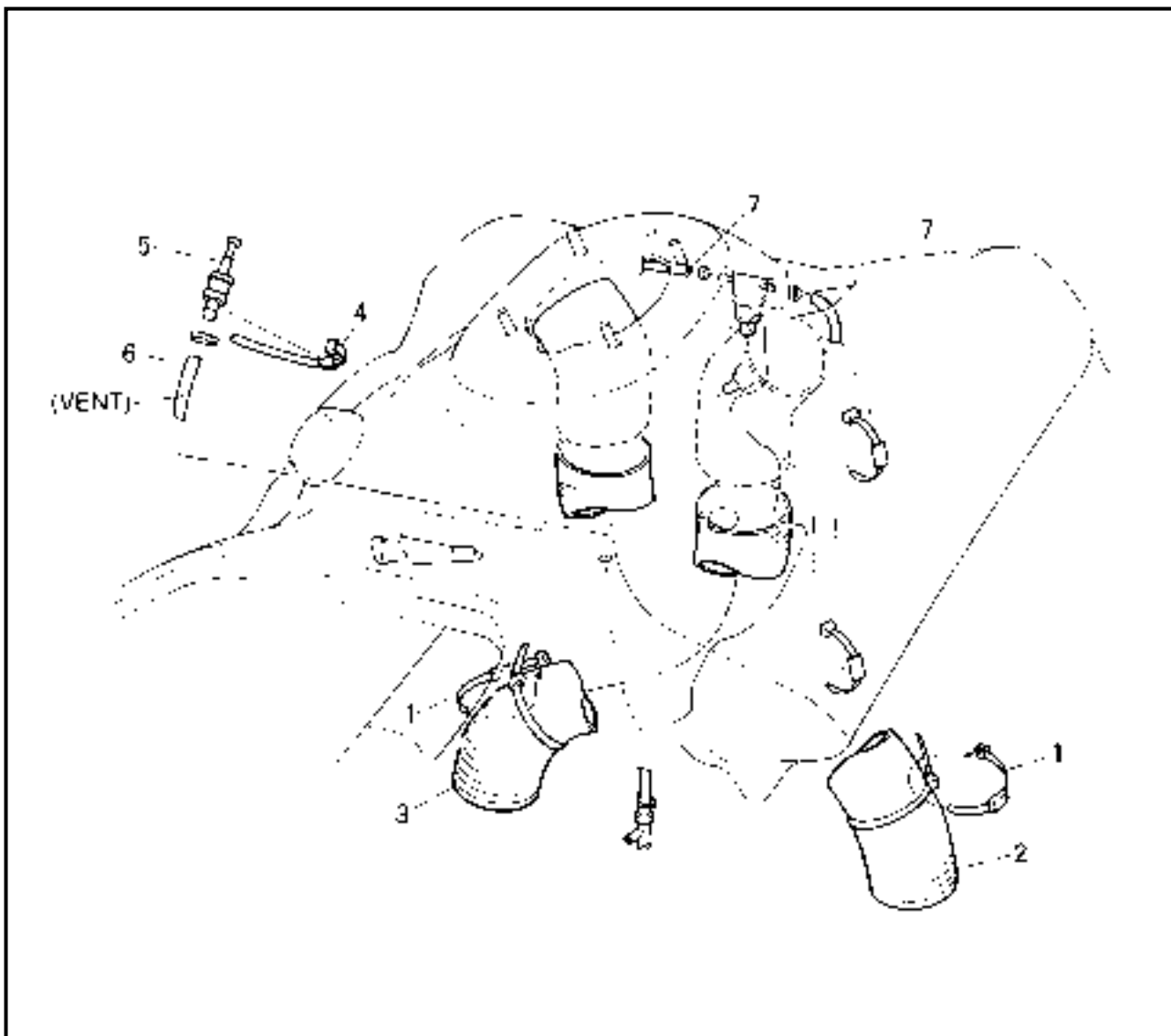

REMOVAL AND INSTALLATION CHART

Step	Procedure/Part name	Q'ty	Service points
	HOSES REMOVAL		
	Engine unit		Follow the left "Step" for removal.
	Steering console cover assembly		Refer to "ENGINE UNIT" in chapter 5.
			Refer to "STEERING CONSOLE COVER".
1	Band	2	
2	Ventilation hose (stern side)	1	NOTE: _____
3	Ventilation hose (bow side)	1	<ul style="list-style-type: none"> ● Route the ventilation hose (bow side) in front of the fuel level sensor lead. ● Route the ventilation hose (stern side) front the oil level sensor lead and the oil tank breather hose.

EXPLODED DIAGRAM

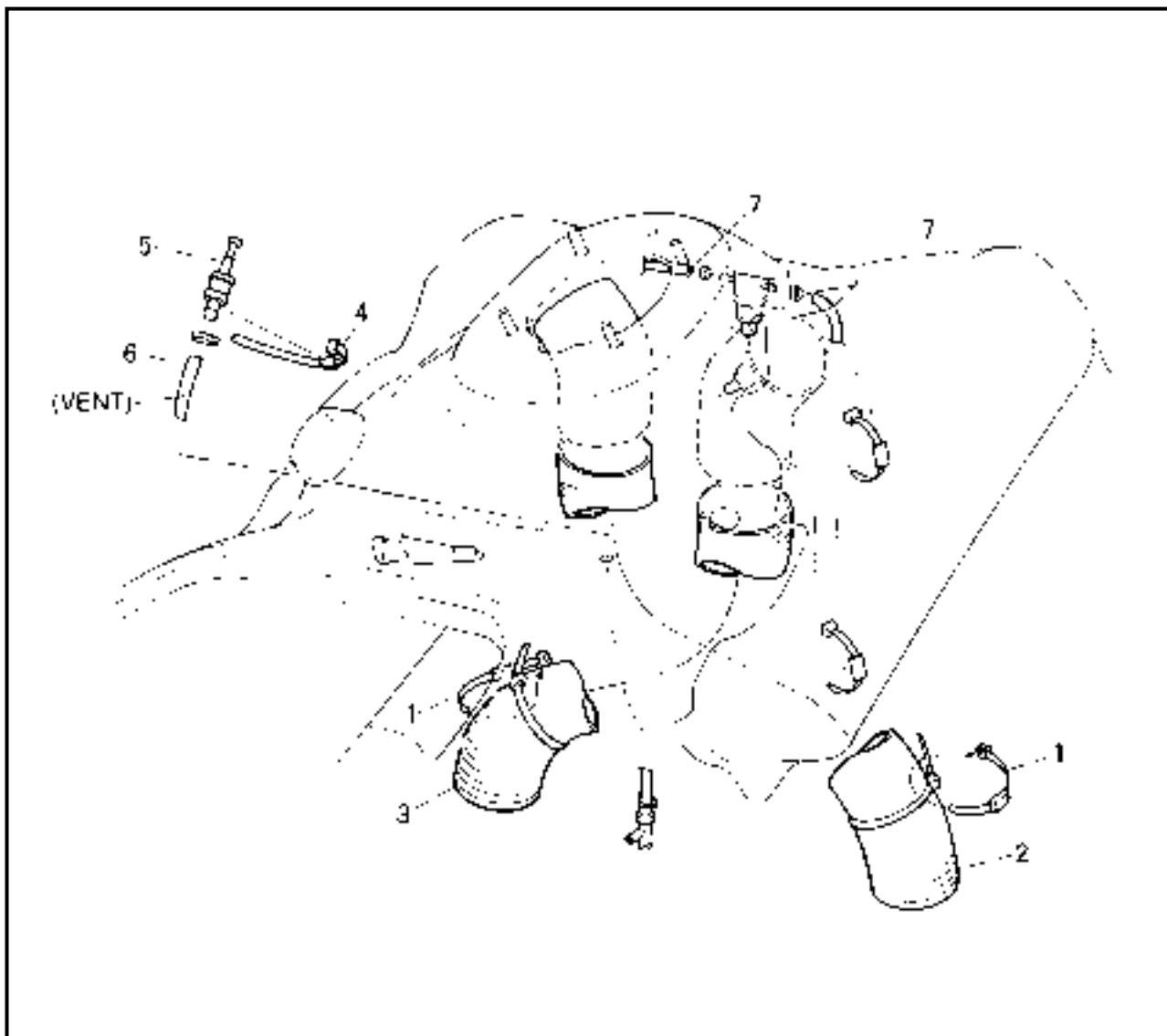

Step	Procedure/Part name	Q'ty	Service points
4	Band	1	Reverse the removal steps for installation.
5	Check valve	1	
6	Oil tank breather hose	1	
7	Fuel tank breather hose	2	

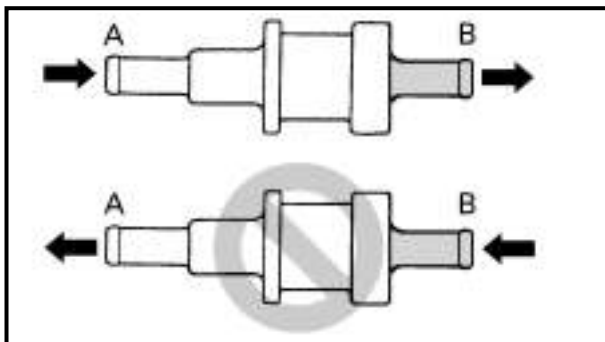

SERVICE POINTS

Check valve inspection

1. Check:
 - Check valve
 Faulty → Replace.

Checking steps:

- Connect a hose to the end of check valve "A" and blow into it. Air should come out from end "B".
- Connect the hose to the end of check valve "B" and blow into it. Air should not come out from end "A".

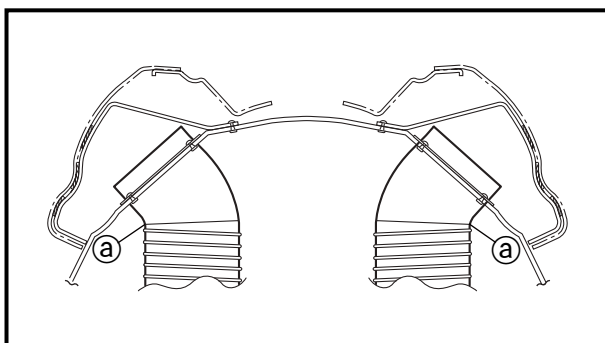

Ventilation hose installation

1. Install:
 - Ventilation hose

NOTE: _____
 Insert the ventilation hose into the ventilation fitting until it reaches the bend @ in the fitting.

**SEATS AND HAND GRIP
EXPLODED DIAGRAM**

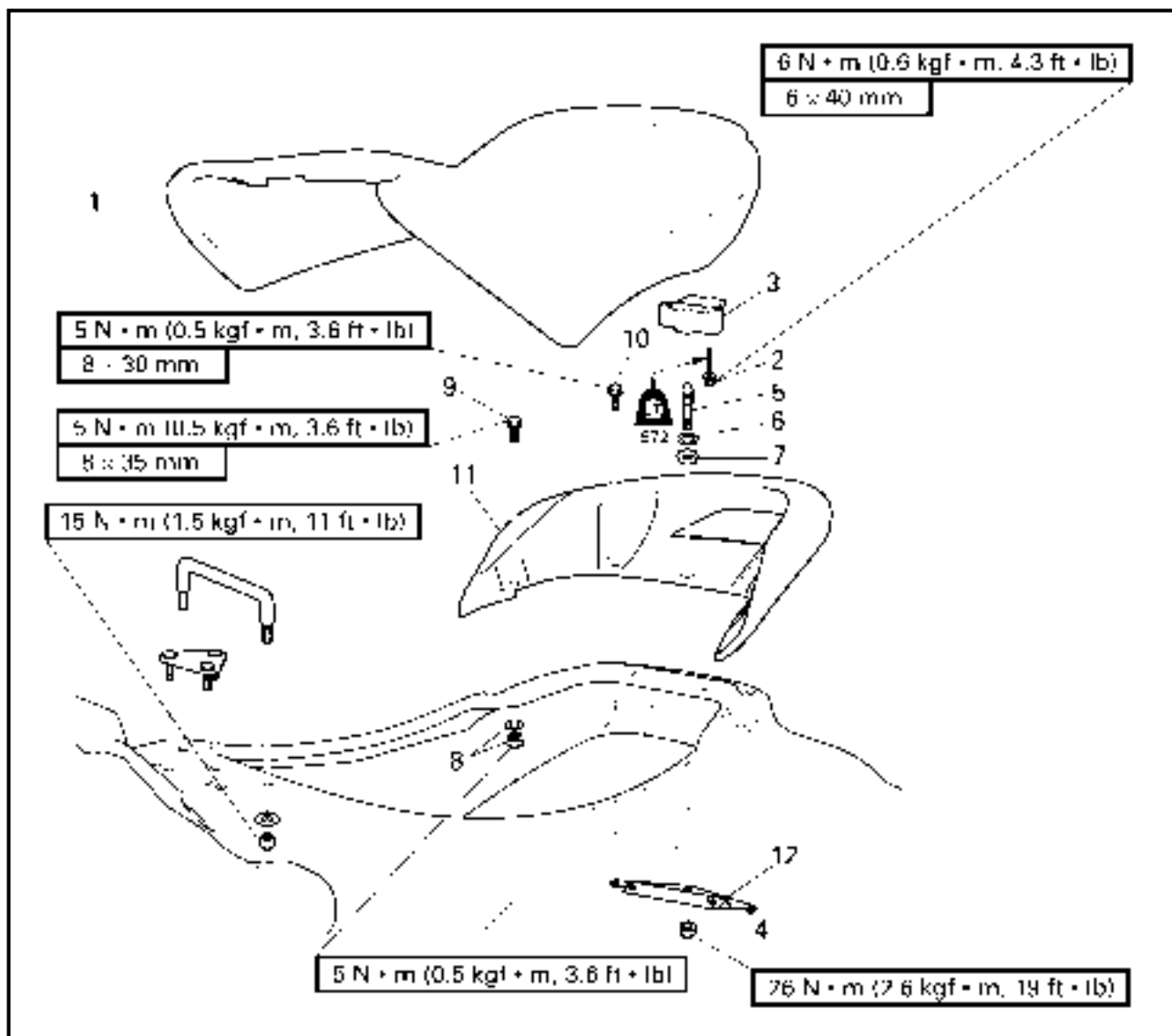

REMOVAL AND INSTALLATION CHART

Step	Procedure/Part name	Q'ty	Service points
	SEATS AND HAND GRIP REMOVAL		Follow the left "Step" for removal.
1	Seat assembly	1	
2	Bolt	2	
3	Seat lock assembly	1	
4	Nut	1	
5	Notch	1	
6	Washer	1	

EXPLODED DIAGRAM

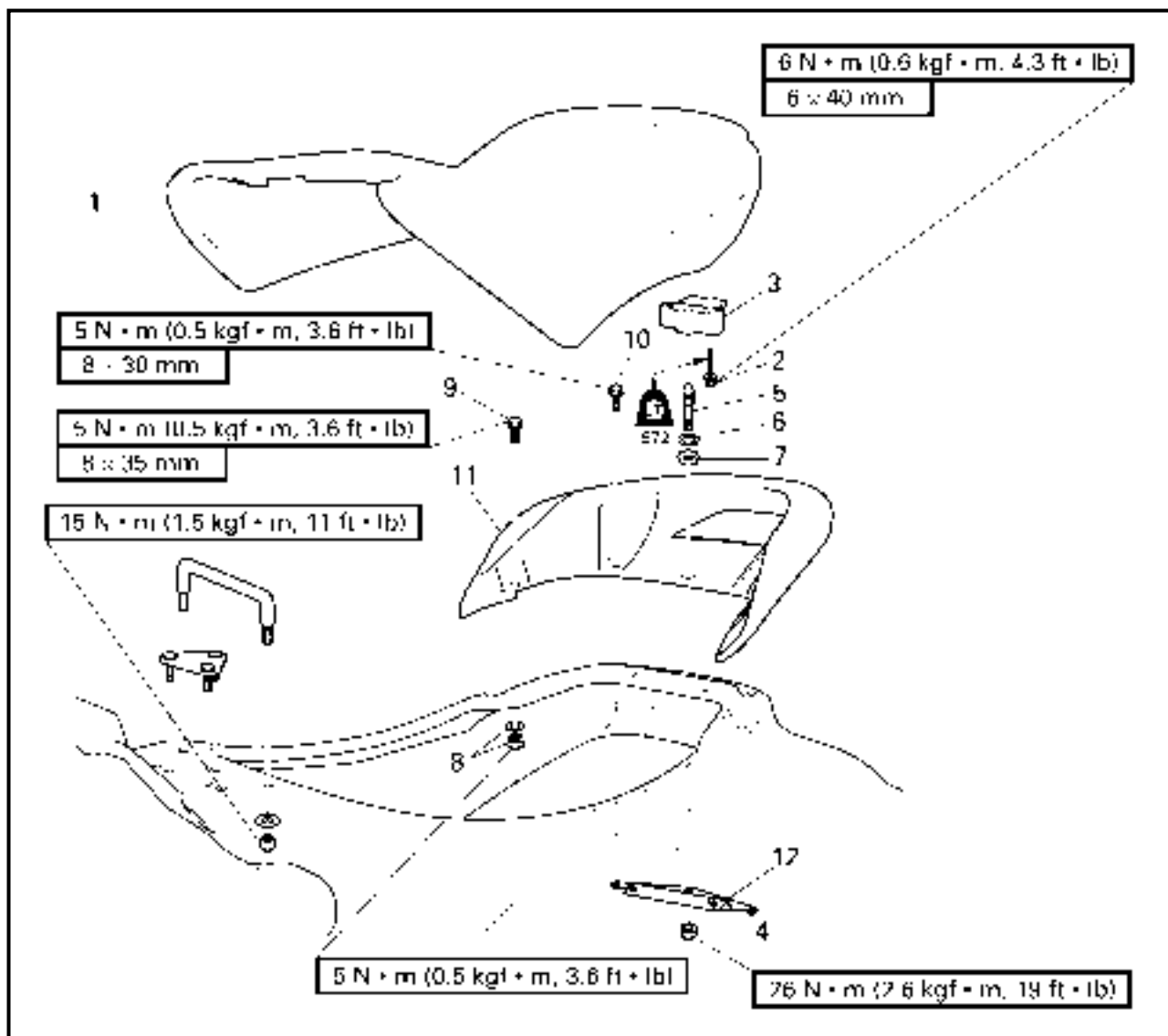

Step	Procedure/Part name	Q'ty	Service points
7	Rubber ring	1	Reverse the removal steps for installation.
8	Nut/washer	2/2	
9	Bolt	2	
10	Bolt	2	
11	Hand grip	1	
12	Bracket	1	



SERVICE POINTS

Seat lock inspection

1. Inspect:

- Seat lock

Damage/wear → Replace.

**BATTERY BOX
EXPLODED DIAGRAM**

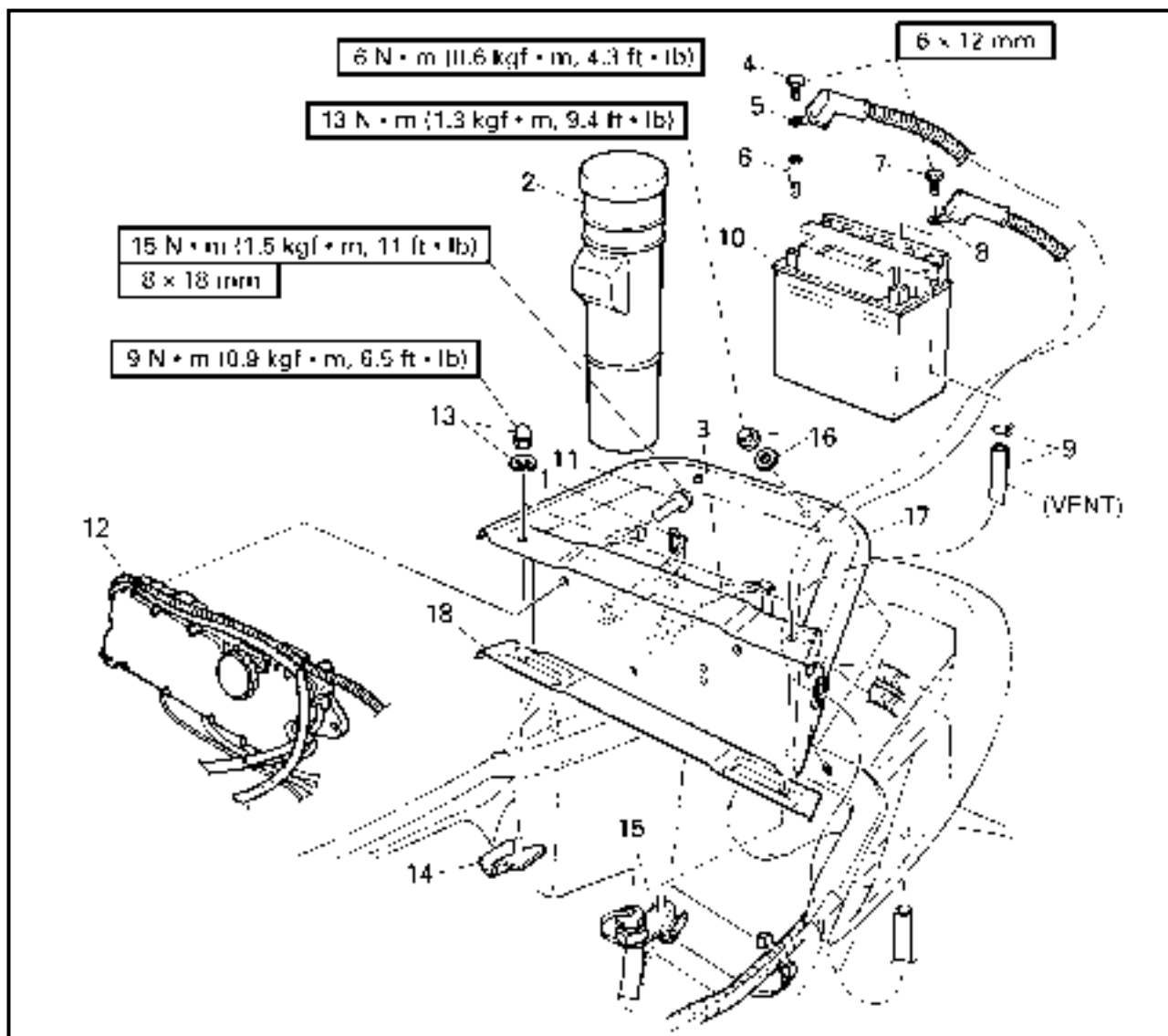

REMOVAL AND INSTALLATION CHART

Step	Procedure/Part name	Q'ty	Service points
	BATTERY BOX REMOVAL		Follow the left "Step" for removal.
1	Band	1	
2	Fire extinguisher container	1	
3	Band	1	
4	Bolt	1	
5	Battery negative lead	1	
6	Terminal extension	1	
7	Bolt	1	
8	Battery positive lead	1	
9	Clip/breather hose	1/1	
10	Battery	1	
11	Bolt	3	

EXPLODED DIAGRAM

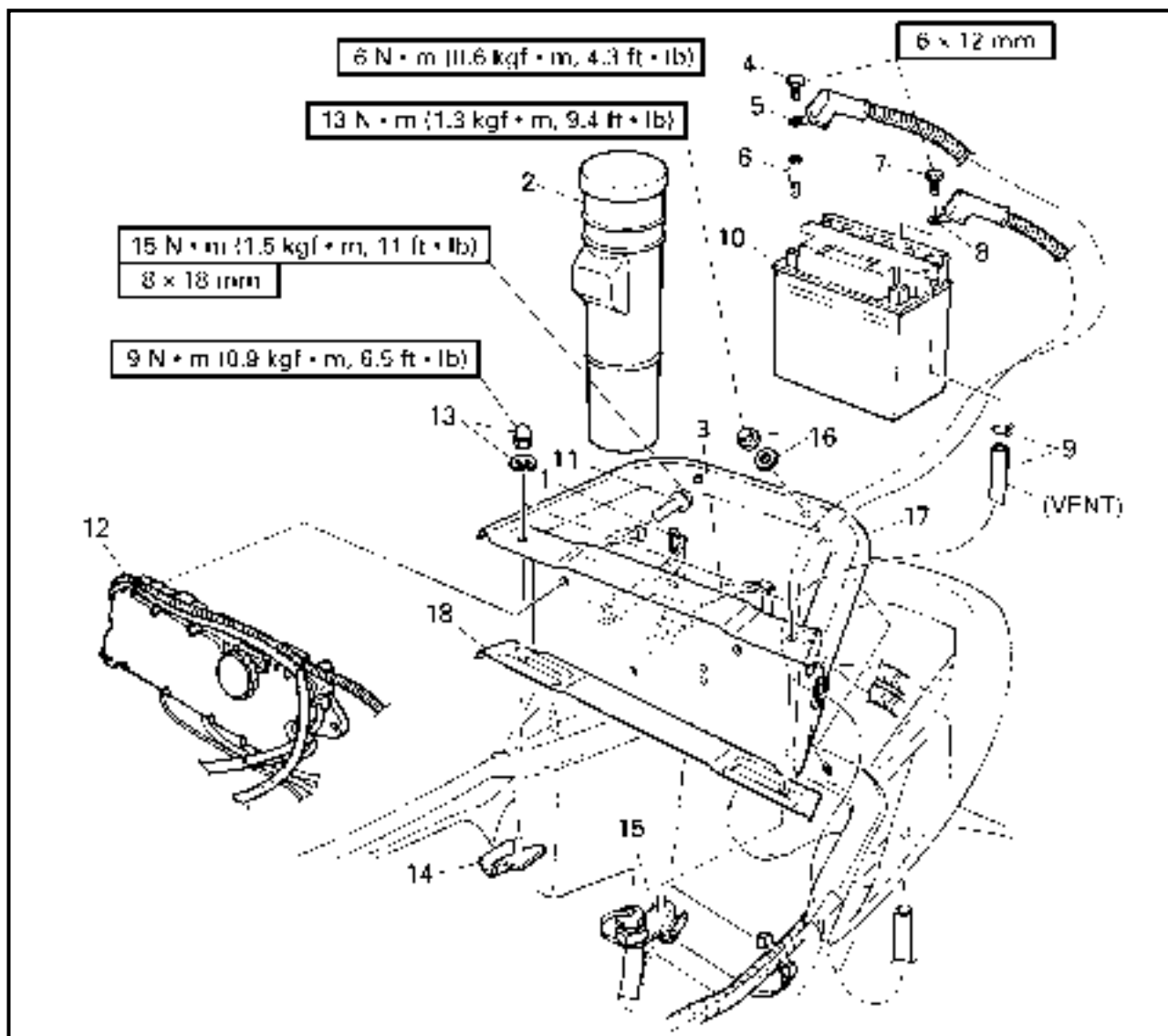

Step	Procedure/Part name	Q'ty	Service points
12	Electrical box	1	<p>NOTE: _____</p> <p>Before installing the battery box, route the battery leads and battery breather hose through the holes of the battery box.</p> <p>_____</p>
13	Cap nut/washer	2/2	
14	Holder	1	
15	Holder	1	
16	Cap nut/washer	2/2	
17	Battery box	1	
18	Stay	1	
			Reverse the removal steps for installation.

**EXHAUST SYSTEM
EXPLODED DIAGRAM**

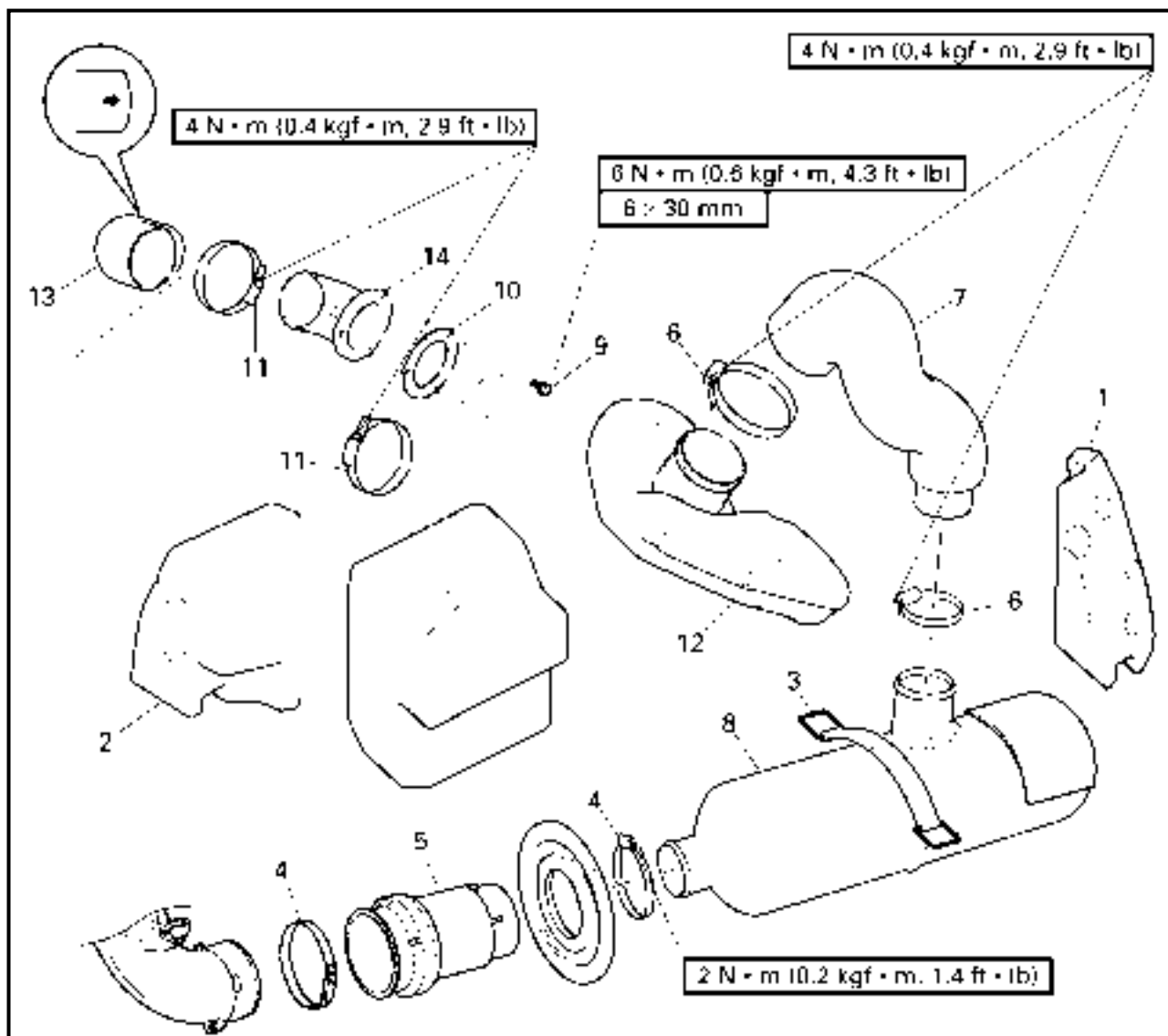

REMOVAL AND INSTALLATION CHART

Step	Procedure/Part name	Q'ty	Service points
	EXHAUST SYSTEM REMOVAL		
	Battery box		Follow the left "Step" for removal. Refer to "BATTERY BOX".
	Jet pump unit assembly		Refer to "JET PUMP UNIT" in chapter 6.
1	Floatation	1	
2	Floatation	1	
3	Water lock band	1	
4	Hose clamp	2	
5	Rubber joint	1	
6	Hose clamp	2	
7	Rubber hose	1	

EXPLODED DIAGRAM

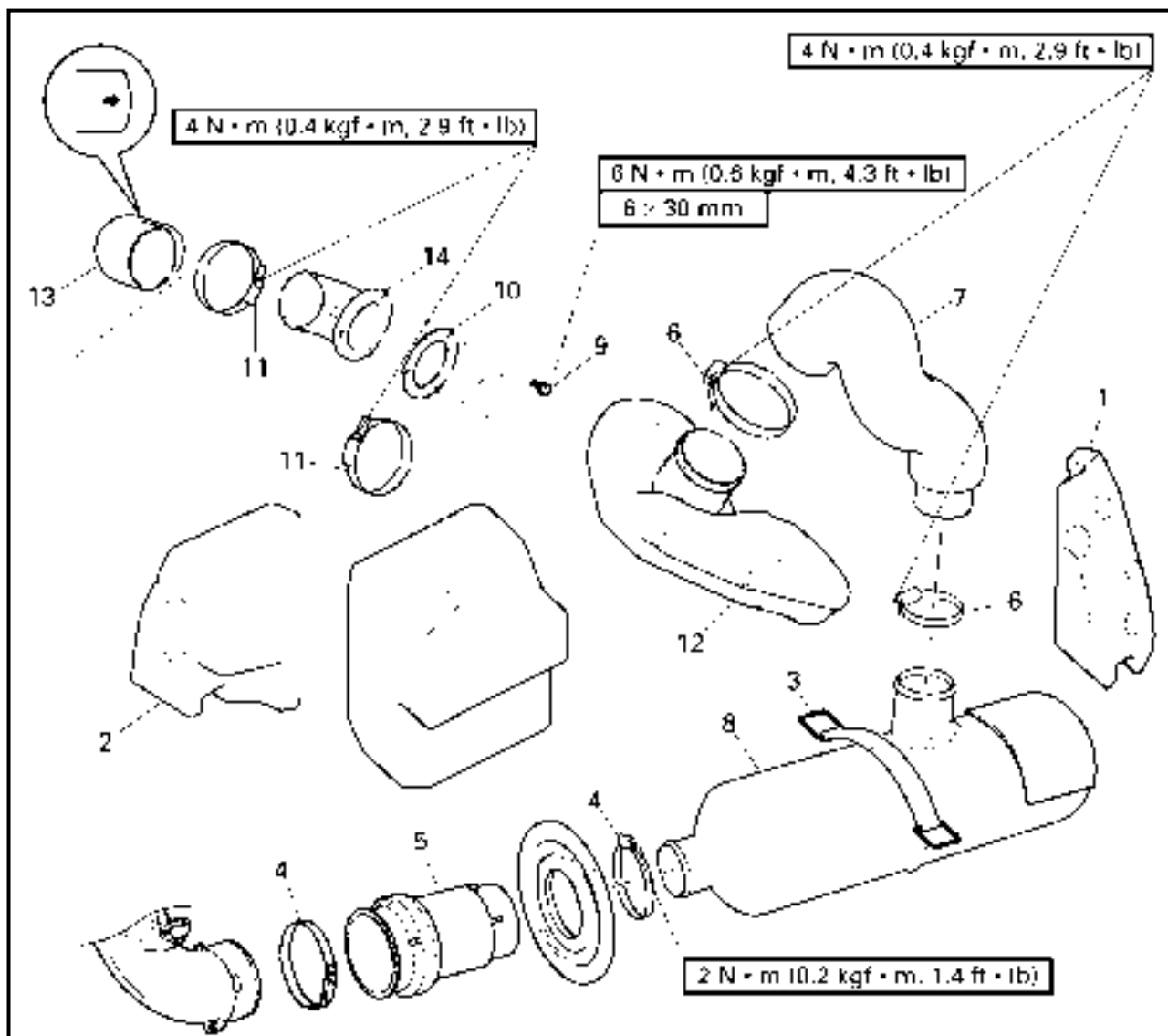

Step	Procedure/Part name	Q'ty	Service points
8	Water lock	1	<p>NOTE: _____</p> <p>Remove parts 11 to 14 as a set.</p> <p>_____</p> <p>Reverse the removal steps for installation.</p>
9	Bolt	3	
10	Packing	1	
11	Hose clamp	2	
12	Water tank	1	
13	Rubber hose	1	
14	Exhaust outlet	1	

SERVICE POINTS

Exhaust system inspection

1. Inspect:
 - Water lock band
Cracks/damage → Replace.
2. Inspect:
 - Rubber hoses
Burns/cracks/damage → Replace.
3. Inspect:
 - Water lock
Cracks/leaks → Replace.
4. Inspect:
 - Water tank
Cracks/damage/leaks → Replace.

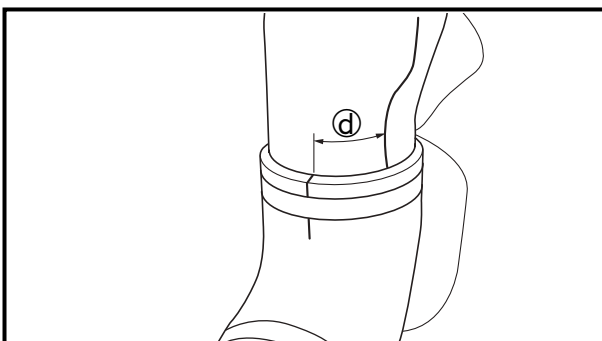
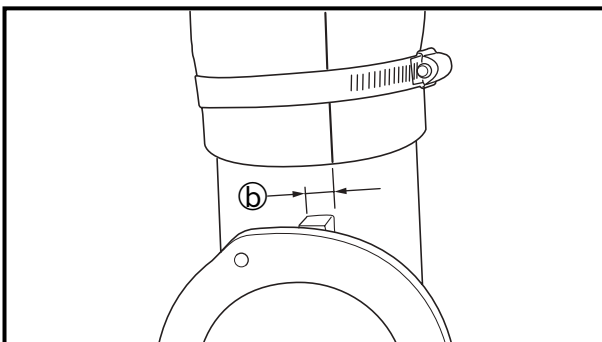
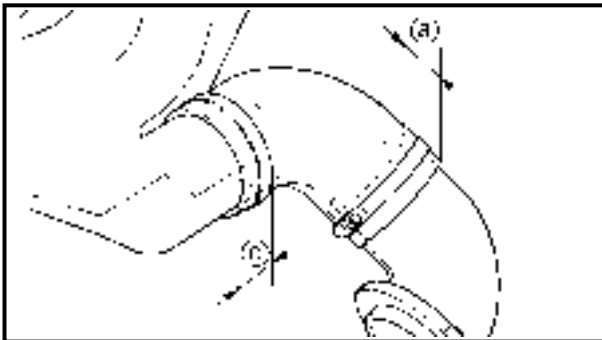

Exhaust component parts sub-assembly

1. Install:
 - Exhaust outlet
 - Rubber hose
 - Water tank

NOTE: _____

- Insert the exhaust outlet 45 mm (1.8 in) (a) into the rubber hose.
 - Make sure that there is a surface distance of 10 mm (0.4 in) (b) between the parting lines of the exhaust outlet and the rubber hose.
 - Insert the water tank 45 mm (1.8 in) (c) into the rubber hose.
 - Make sure that there is a surface distance of 45 mm (1.8 in) (d) between the parting lines of the water tank and rubber hose.
- _____

**DECK AND HULL
EXPLODED DIAGRAM**

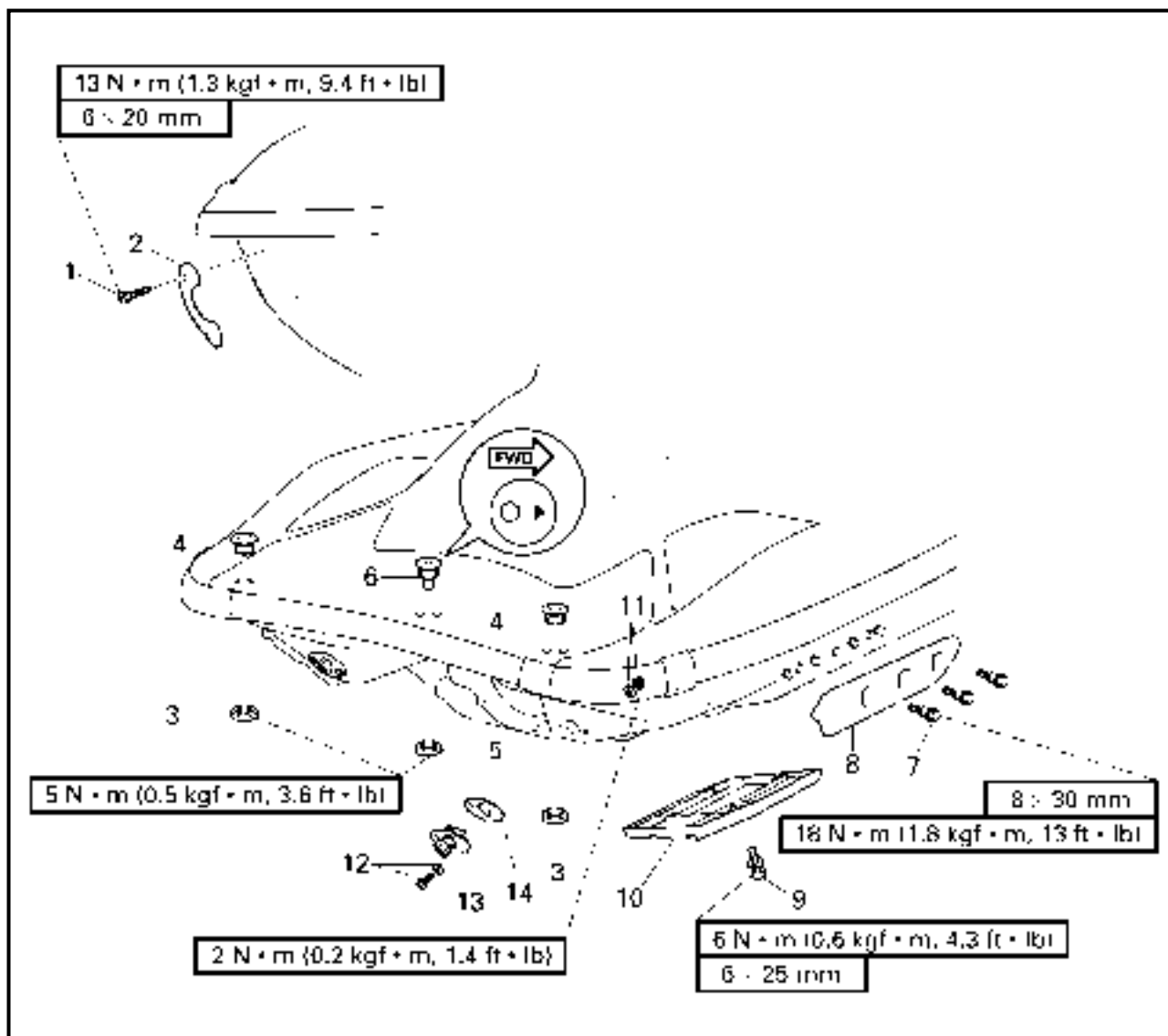

REMOVAL AND INSTALLATION CHART

Step	Procedure/Part name	Q'ty	Service points
DECK AND HULL DISASSEMBLY			Follow the left "Step" for disassembly.
1	Bolt	2	
2	Bow eye	1	
3	Nut	2	
4	Rope hole fitting	2	
5	Nut	1	
6	Spout	1	
7	Bolt	6	

EXPLODED DIAGRAM

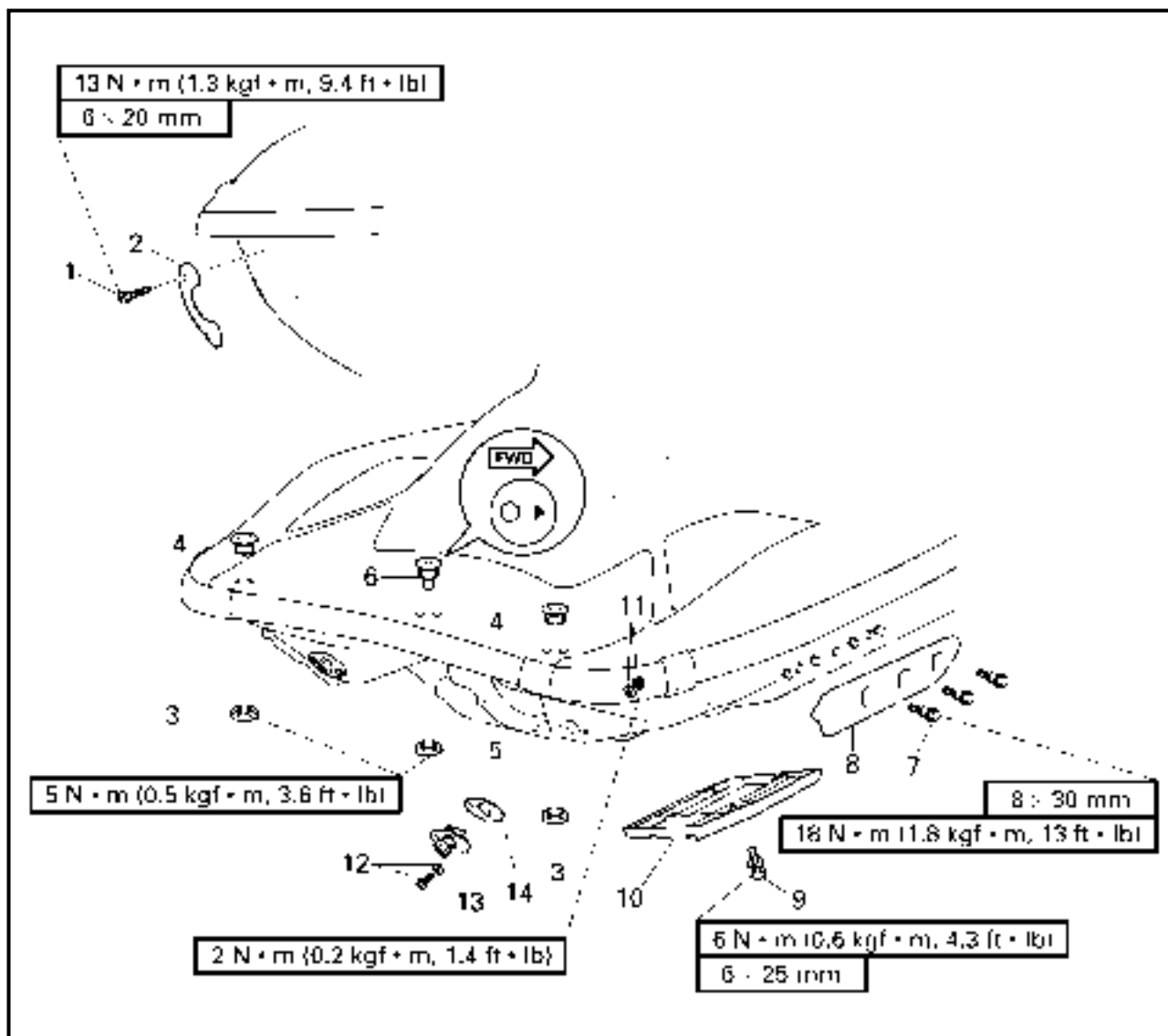

Step	Procedure/Part name	Q'ty	Service points
8	Sponson	2	NOTE: _____ Make sure install the starboard and port side sponsons to the same position. _____
9	Bolt	8	
10	Flap	2	
11	Nut/washer	4/4	
12	Screw/washer	4/4	
13	Drain plug	2	
14	Packing	2	
			Reverse the disassembly steps for assembly.

**ENGINE MOUNT
EXPLODED DIAGRAM**

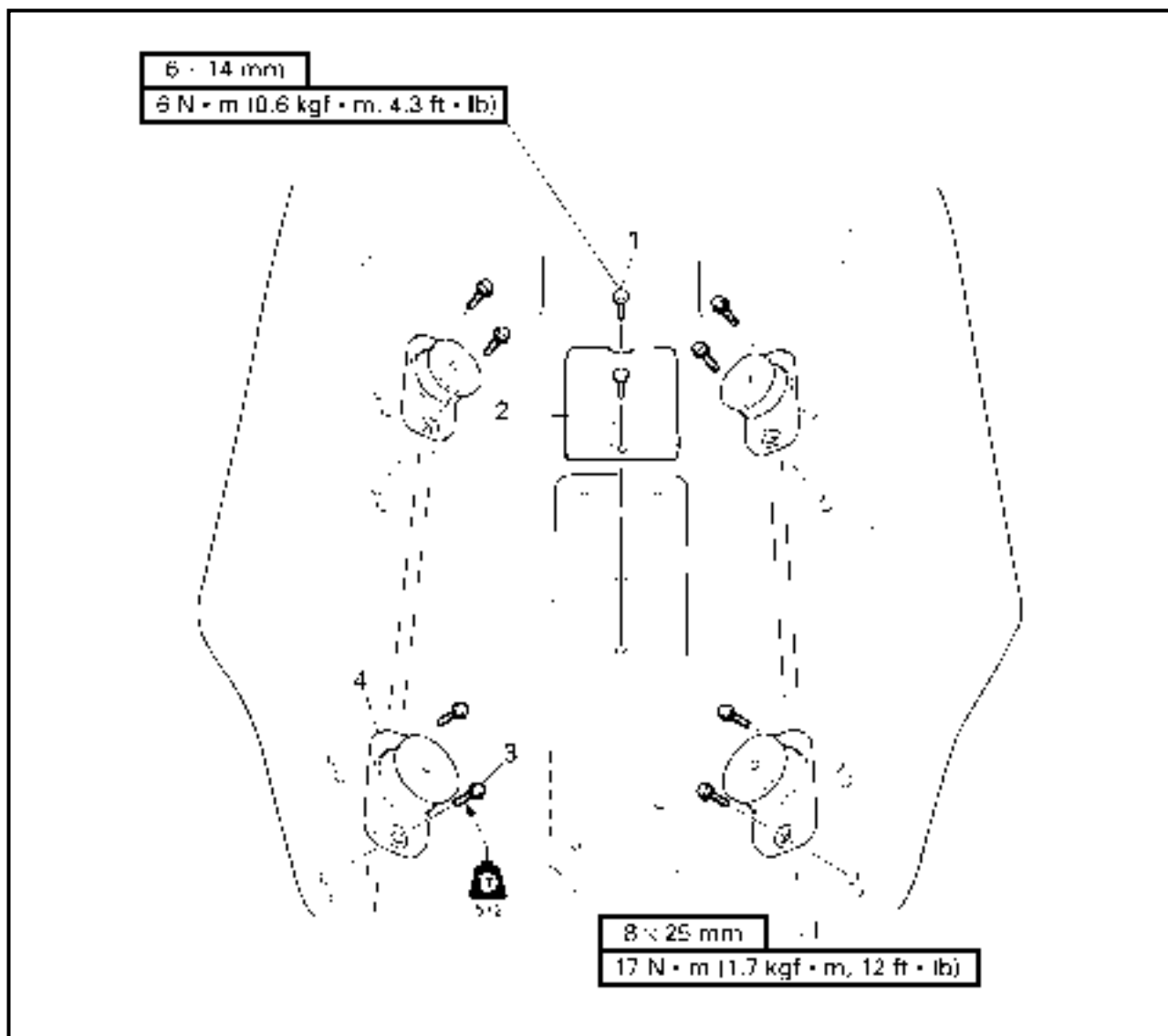

REMOVAL AND INSTALLATION CHART

Step	Procedure/Part name	Q'ty	Service points
	ENGINE MOUNT REMOVAL		
	Engine unit		Follow the left "Step" for removal. Refer to "ENGINE UNIT" in chapter 5.
1	Bolt	2	
2	Damper	1	
3	Bolt	8	
4	Engine mount	4	
			Reverse the removal steps for installation.

HULL REPAIR

Shallow scratches

1. Sand the scratches with 400 grit sandpaper (either wet or dry) until the scratches are smooth. Then, sand the scratches once again with 600 grit sandpaper (either wet or dry).

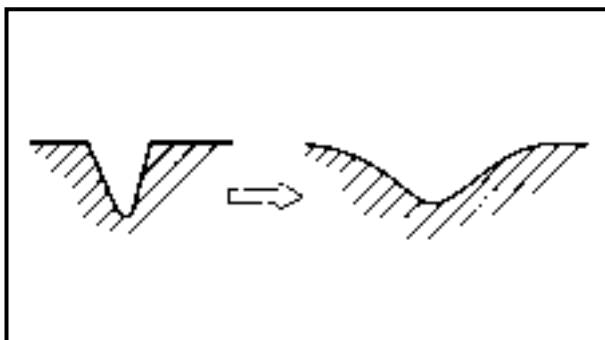

Deep scratches

1. Remove any sharp or rough edges from the hull surface.
2. Sand the scratches and a 1-inch circumference around them with 80 grit sandpaper (either wet or dry).
3. Clean the entire area with acetone and let it completely dry.
4. Mix gel-coat and gel-coat thickener to form a putty, and then add the catalyst to the putty.
5. Apply the putty, spread it with a squeegee, and then cover the putty with wax paper.
6. When the putty has set, sand it. Smooth the area with 80–400 grit sandpaper (either wet or dry) and a sanding block.
7. Clean the area with a dry cloth and then polish it.

⚠ WARNING

Resins, catalysts, and solvents are flammable and toxic; only use them in a well-ventilated area and keep them away from open flames and sparks. Always follow the manufacturer's instructions and warnings.

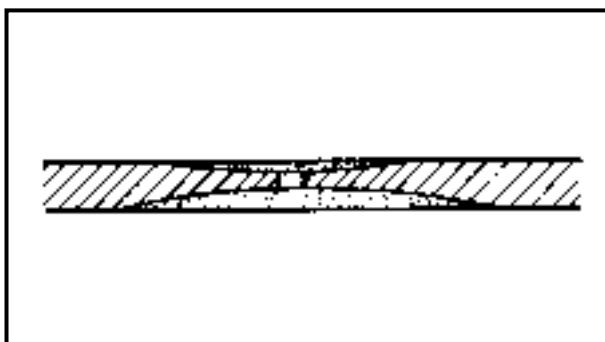
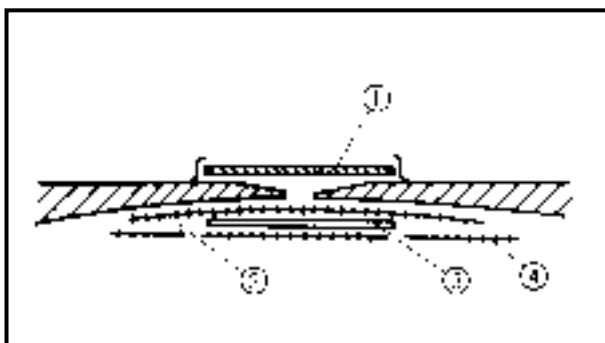
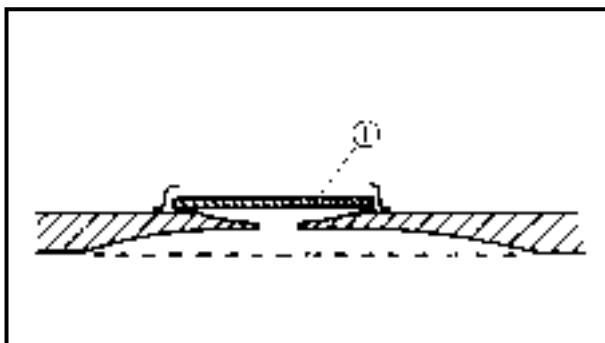
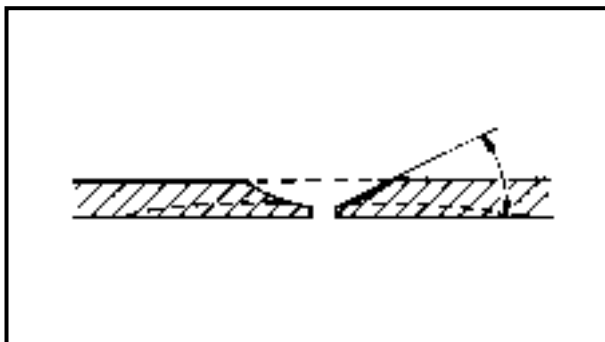

Cracks and punctures

NOTE: _____

Before attempting to repair any cracks or punctures, refer to "WATERCRAFT FRP REPAIR MANUAL".

1. Remove any damaged fiberglass.
2. Cut the damaged area and separate it approximately 0.25 inch.
3. On the outside of the hull, grind the separated edge of the area to less than 5° as shown.
4. Working from inside the hull, grind the damaged area approximately 4 inches beyond the damage.
5. Clean the area with acetone, apply BP-1 or an equivalent primer onto both sides of the damaged area, and then allow it to cure for approximately 30 minutes.
6. Cover a piece of cardboard with wax paper ① and then cover the damaged area with it.
7. Combine the polyester resin and the catalyst, and then apply the mixture onto the hull.
8. Install a glass mat ② (2 inches smaller than the ground area).
9. Apply the resin.
10. Install a 20 oz. fiberglass cloth ③ (1 inch smaller than the glass mat).
11. Apply the resin.
12. Install another glass mat ④ (1 inch smaller than the ground area).
13. When the resin has hardened remove the piece of cardboard.
14. Finish the outer surface.
Refer to steps (3)–(7) in the "Deep scratches" section.

Insert nut

NOTE: _____

Use the insert nut when:

- A pop nut which was attached to the hull slipped off or,
- When a bolt which was fastened to an insert nut or pop nut broke.

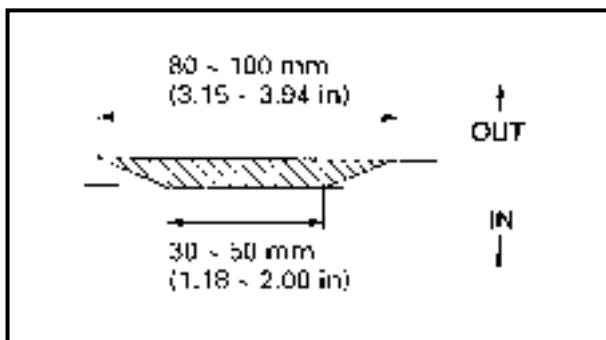
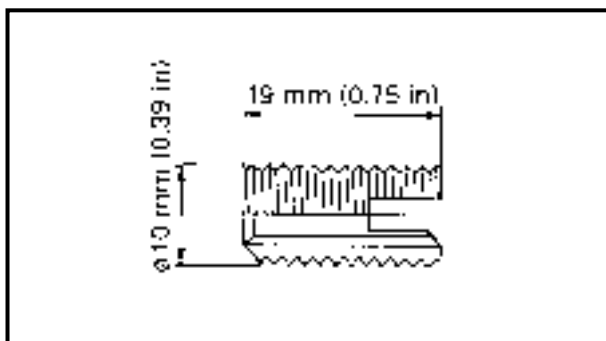
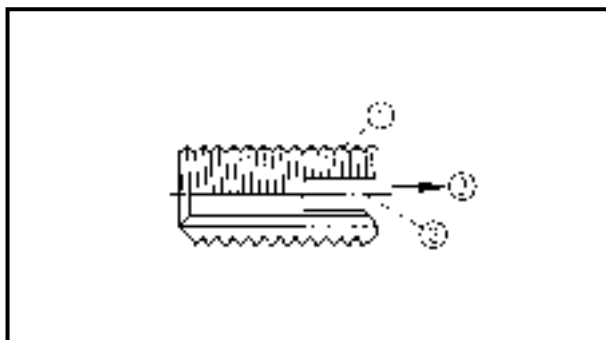

Part No.	Part name	Remarks
EW2-62733-09	Nut	Stainless steel, M6

- Nut ①
- Thread direction ②
- Slot to be threaded ③

NOTE: _____

Drilling size

Material	Pilot hole diameter
FRP or SMC	9.1-9.2 mm (0.36 in)
Brass	9.4 mm (0.37 in)

Example 1:

NOTE: _____

Before attempting to install the insert nut, refer to "WATERCRAFT FRP REPAIR MANUAL".

The insert nut is used to repair the pop nut designed for the ride plate.
(By repairing the FRP portion, the insert nut can be used for all models.)

1. Remove:
 - Pop nut
2. Clean the surface to be scarfed and the inside of the hull with acetone.
3. Scarf the shaded portion of the hull.

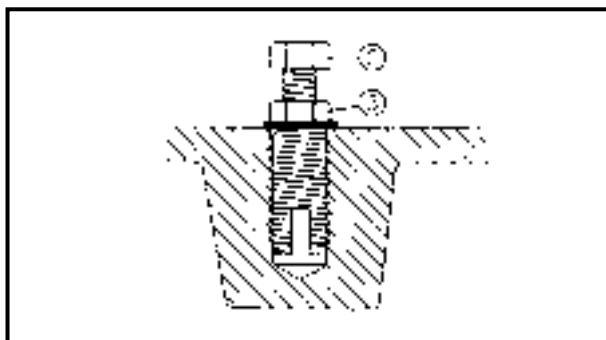
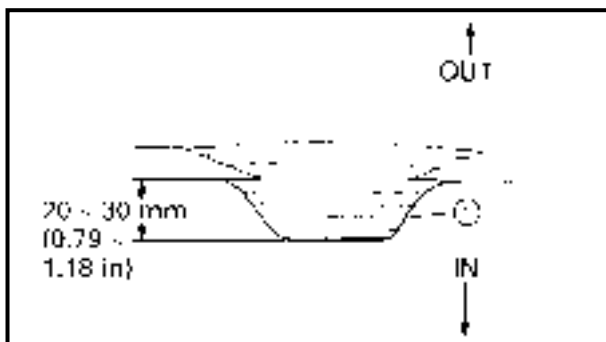

4. First, apply tape ① to the inner surface of the hull and then laminate fiberglass mats over the tape with resin.

NOTE: _____

When it is possible to work inside the hull, laminate the mats from the inside.

5. Sand the outer surface of the hull until it is smooth.
6. Install the ride plate.
7. Drill a 20 mm (0.79 in) deep hole in the center of the laminated fiberglass layers with a 9.2 mm (0.36 in) diameter drill bit.
8. Pass the bolt ② through the insert nut and lock the bolt with the nut ③ as shown.
9. Screw in the insert nut so that the top is flush with the FRP surface.
10. Loosen the locknut and remove the bolt.

CAUTION: _____

- Only use a steel bolt with a tensile strength of 8T or more.
- If the bolt is inferior in strength or is made of stainless steel it may break.

- Bolt ②
- Locknut ③

Example 2:

The brass insert nut, which is designed for the Super Jet ride plate or the intake screen, is used as follows.

NOTE: _____

If the bolt is broken, drill it out.

1. Drill a hole in the hull.

NOTE: _____

- First, use a small-diameter drill bit followed by drill bits of gradually increasing diameter.
- Use a 9.4 mm (0.37 in) drill bit for the final drilling.

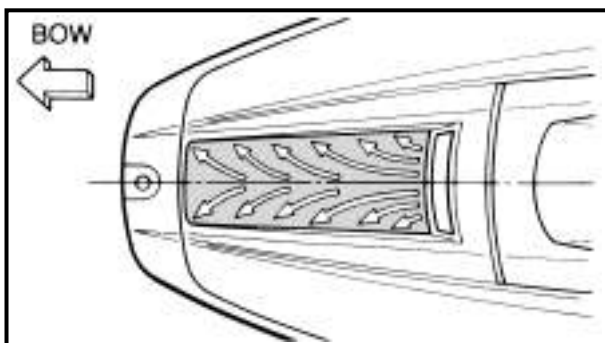
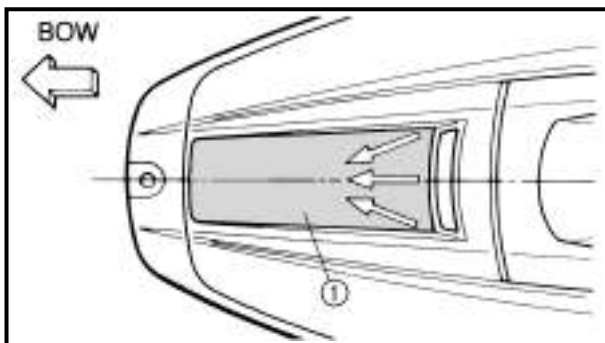
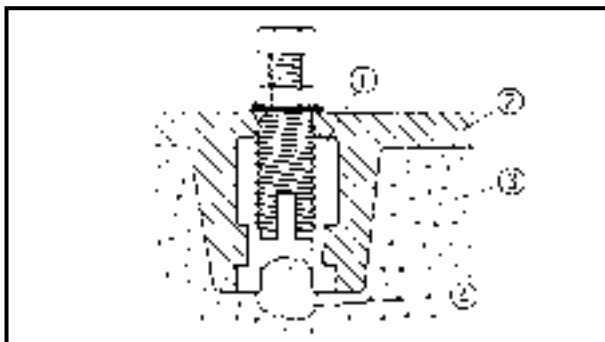

2. To prevent water from entering the urethane foam, apply silicone sealant to the inside of the hole as shown.
3. Install the insert nut as explained in "Example 1".
 - Brass insert nut ①
 - Hull ②
 - Urethane foam ③
 - Silicone sealant ④

Graphic removal

1. Hold a hair dryer approximately 1.5 inches above the graphic ①.
2. Apply heat to one corner of the graphic.
3. Slowly peel off the heated portion of the graphic and continue working until you reach the opposite corner and the entire graphic is removed.
4. After the graphic is removed, clean the entire bow area with isopropyl alcohol to remove any residual adhesive.

Graphic installation

1. Mix 1 tablespoon of liquid detergent and water in a 1-quart spray bottle.
2. Remove the backing from the new graphic.
3. Spray the soap and water mixture onto both sides of the graphic, and also onto the hull area where the graphic will be installed.

NOTE: _____

Spraying the front of the graphic with the soap and water mixture will protect it from being scratched during installation.

4. Align the graphic onto the fitting area of the hull and position it with a squeegee.

NOTE: _____

Be sure to remove any air bubbles from the graphic with the squeegee. Work from the top of the graphic down and slide the squeegee outwards from the graphic's center line.

5. Allow the graphic to dry before waxing or using the watercraft.

CHAPTER 9 TROUBLE ANALYSIS

TROUBLE ANALYSIS 9-1
TROUBLE ANALYSIS CHART 9-1

TROUBLE ANALYSIS

NOTE:

The following items should be checked before the "Trouble analysis" chart is consulted.

1. The battery is charged and its specified gravity is within specification.
2. There are no incorrect wiring connections.
3. Wiring connections are properly secured and not rusty.
4. The lock plate is attached to the engine stop lanyard switch.
5. Fuel is reaching the carburetors.

TROUBLE ANALYSIS CHART

Problems											Items to be checked	
ENGINE WILL NOT START	ROUGH IDLING	ENGINE STALLS	ENGINE WILL NOT STOP	POOR PERFORMANCE	OVERHEATING	LOOSE STEERING	BILGE INCREASE	IRREGULAR WARNING INDICATION	POOR BATTERY CHARGING	YPVS SERVOMOTOR DOES NOT MOVE	Items	Reference chapter
											FUEL SYSTEM	
<input type="checkbox"/>	<input type="checkbox"/>	<input type="checkbox"/>	<input type="checkbox"/>	<input type="checkbox"/>							Fuel tank	4
<input type="checkbox"/>	<input type="checkbox"/>	<input type="checkbox"/>	<input type="checkbox"/>	<input type="checkbox"/>							Fuel tank breather hose	4
<input type="checkbox"/>	<input type="checkbox"/>	<input type="checkbox"/>	<input type="checkbox"/>	<input type="checkbox"/>							Fuel hose	4
<input type="checkbox"/>	<input type="checkbox"/>	<input type="checkbox"/>	<input type="checkbox"/>	<input type="checkbox"/>							Fuel filter	4
<input type="checkbox"/>	<input type="checkbox"/>	<input type="checkbox"/>	<input type="checkbox"/>	<input type="checkbox"/>							Fuel pump	4
<input type="checkbox"/>	<input type="checkbox"/>	<input type="checkbox"/>	<input type="checkbox"/>	<input type="checkbox"/>							Carburetors	4
	<input type="checkbox"/>	<input type="checkbox"/>	<input type="checkbox"/>	<input type="checkbox"/>							Carburetor synchronization	4
		<input type="checkbox"/>	<input type="checkbox"/>	<input type="checkbox"/>							Trolling speed	3
											POWER UNIT	
<input type="checkbox"/>				<input type="checkbox"/>							Spark plug(s)	3
<input type="checkbox"/>	<input type="checkbox"/>			<input type="checkbox"/>							Compression	5
<input type="checkbox"/>	<input type="checkbox"/>			<input type="checkbox"/>							Reed valves	5
<input type="checkbox"/>	<input type="checkbox"/>			<input type="checkbox"/>							Cylinder head gasket	5
<input type="checkbox"/>				<input type="checkbox"/>							Piston rings	5
<input type="checkbox"/>				<input type="checkbox"/>							Cylinder block	5
<input type="checkbox"/>				<input type="checkbox"/>							Seals	5
<input type="checkbox"/>				<input type="checkbox"/>							Crankcase	5
<input type="checkbox"/>				<input type="checkbox"/>							Pistons	5
	<input type="checkbox"/>			<input type="checkbox"/>							Bearings	5
				<input type="checkbox"/>							Bearing housing	5
	<input type="checkbox"/>			<input type="checkbox"/>							Drive couplings	5
				<input type="checkbox"/>							Rubber coupling	5

Problems											Items to be checked	
ENGINE WILL NOT START	ROUGH IDLING	ENGINE STALLS	ENGINE WILL NOT STOP	POOR PERFORMANCE	OVERHEATING	LOOSE STEERING	BILGE INCREASE	IRREGULAR WARNING INDICATION	POOR BATTERY CHARGING	YPVS SERVOMOTOR DOES NOT MOVE	Items	Reference chapter
					<input type="radio"/>		<input type="radio"/>				Pilot water hose	5
					<input type="radio"/>		<input type="radio"/>				Water hose	5
					<input type="radio"/>		<input type="radio"/>				Water passage	5
JET PUMP UNIT												
				<input type="radio"/>	<input type="radio"/>		<input type="radio"/>				Duct	6
				<input type="radio"/>							Impeller	6
				<input type="radio"/>	<input type="radio"/>						Intake grate	6
	<input type="radio"/>			<input type="radio"/>							Bearings	6
				<input type="radio"/>	<input type="radio"/>						Intake duct	6
					<input type="radio"/>						Water inlet hose	6
							<input type="radio"/>				Bilge hose	6
							<input type="radio"/>				Bilge strainer	6
							<input type="radio"/>				Bilge hose joint	6
							<input type="radio"/>				Valve body	6
ELECTRICAL												
<input type="radio"/>	<input type="radio"/>	<input type="radio"/>	<input type="radio"/>	<input type="radio"/>				<input type="radio"/>		<input type="radio"/>	CDI unit	7
									<input type="radio"/>		Lighting coil	7
<input type="radio"/>		<input type="radio"/>									Charge coil	7
<input type="radio"/>		<input type="radio"/>		<input type="radio"/>							Pickup coil (Pulser coil)	7
<input type="radio"/>		<input type="radio"/>		<input type="radio"/>							Ignition coil	7
				<input type="radio"/>					<input type="radio"/>		Rectifier/regulator	7
<input type="radio"/>		<input type="radio"/>						<input type="radio"/>			Electrical sensor(s)	7
<input type="radio"/>											Starter relay, starter motor	7
				<input type="radio"/>						<input type="radio"/>	YPVS unit	7
<input type="radio"/>									<input type="radio"/>		Battery	3
<input type="radio"/>									<input type="radio"/>		Fuse(s)	7
<input type="radio"/>				<input type="radio"/>					<input type="radio"/>	<input type="radio"/>	Wire harness, electrical coupler(s)	7
HULL AND HOOD												
						<input type="radio"/>					Steering column	8
				<input type="radio"/>			<input type="radio"/>				Water lock	8
		<input type="radio"/>		<input type="radio"/>			<input type="radio"/>				Exhaust hose	8
				<input type="radio"/>			<input type="radio"/>				Muffler	8
							<input type="radio"/>				Drain plugs	8

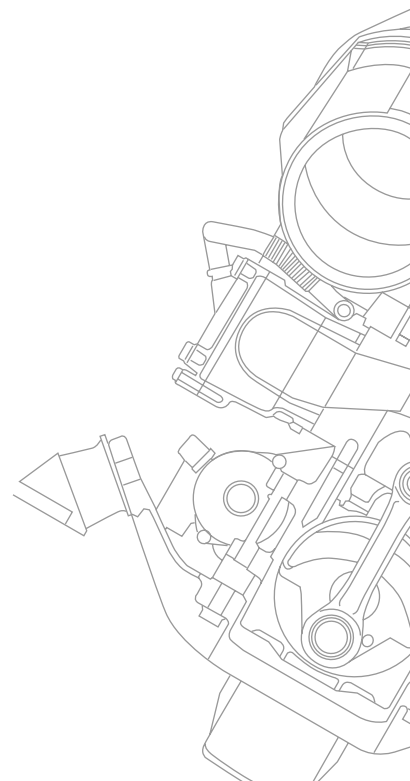
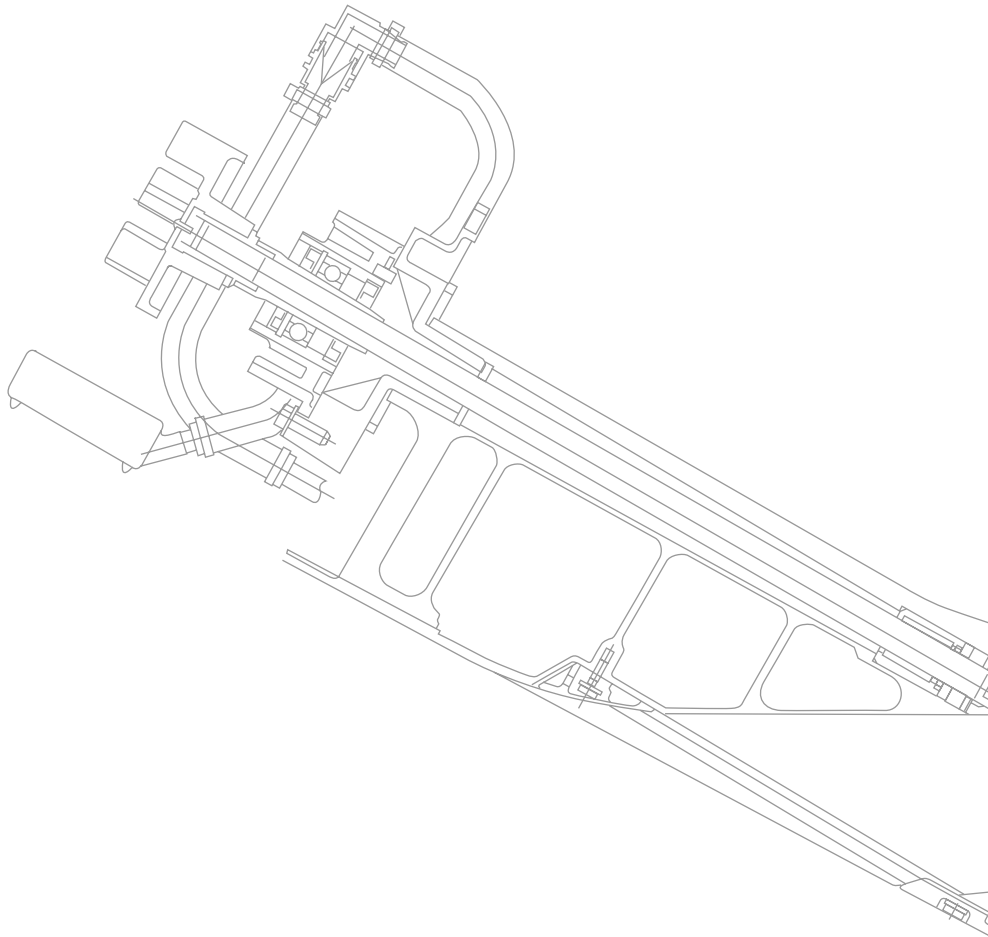

Printed in USA
Nov. 2000 — × 1 CR
F0W-28197-1A-11
(GP800A)
(英)

WIRING DIAGRAM GP800R

COLOR CODE

● B : Black	● Y : Yellow
● Br : Brown	● B/Y : Black/yellow
● G : Green	● L/B : Blue/black
● Gy : Gray	● L/R : Blue/red
● L : Blue	● R/W : Red/white
● O : Orange	● R/Y : Red/yellow
● P : Pink	● W/B : White/black
● R : Red	● W/L : White/blue
○ W : White	● W/R : White/red

