

Supra

— 20', 21', & 23' SERIES

Owner's Manual

The SUPRA 20', 21', and 23' SERIES are manufactured by Supra Sports, Inc. in Greerback, Tennessee, and are distributed throughout the United States and abroad.

This manual should be considered a permanent part of your Supra. It should remain with the boat when sold to provide the next owner with information on safety, operation, and maintenance.

All information, illustrations, and specifications in this manual are based on the latest product information available at the time of printing. However, Supra Sports, Inc. reserves the right to make changes at any time without notice.

A boating maintenance schedule and accessory information are included in this manual. All warranty information regarding your Supra has also been provided so as to insure your complete satisfaction should service needs arise.

A WORD TO SUPRA OWNERS

The Supra staff strongly recommends that you carefully read and familiarize yourself with all instructions and recommendations presented in this manual so as to assure pleasurable and trouble-free operation. Keep this manual in a safe and dry area aboard your Supra as permanent reference material.

This manual contains suggestions to assist you in properly maintaining all areas of your Supra. Drawings and explanations of detailed accessories have been provided to acquaint you with unfamiliar areas in your Supra.

Should service problems arise, remember that your Supra dealer knows your boat best and is interested in your total satisfaction.

We at Supra Sports thank you for choosing a Supra product and assure you that your boating pleasure and satisfaction will continue to be our number one priority.

MODIFICATION OF YOUR SUPRA

Any modification of your Supra may affect performance, safety, durability, void the warranty, or may violate Coast Guard or governmental regulations.

FUEL INFORMATION

DO NOT use gasolines containing any alcohol, ethanol, or methanol. Vapors from these gases are highly flammable.

It is recommended that gasoline types not be changed from one to another.

Gasolines containing detergents, additives, and stabilizers are safe to use.

Each Supra is equipped with STA-BIL® gasoline stabilizer before leaving the factory.

If winter storing, or any storage period of at least 3 months, with a full tank, gasoline stabilizer such as STA-BIL® will reduce gum formation, varnishing, condensation, etc.

TABLE OF CONTENTS

EQUIPMENT AND OPTIONS ①

OPERATIONAL INFORMATION ②

SERVICE & MAINTENANCE ③

TECHNICAL ④

WARRANTY ⑤

<https://www.boat-manuals.com/>

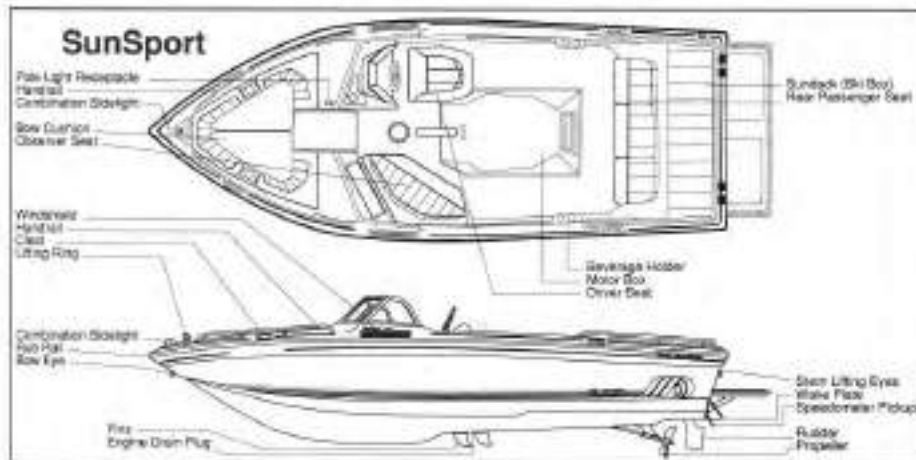

20' Series

Specifications

Length	20' 3 1/2"
Width (Beam)	96"
Width (Transom)	81"
Draft (At Stop)	24"
Depth (Amidship)	48"
Weight	2,950 lbs.
Fuel Capacity	37 U.S. Gallons
Capacity (Persons)	8

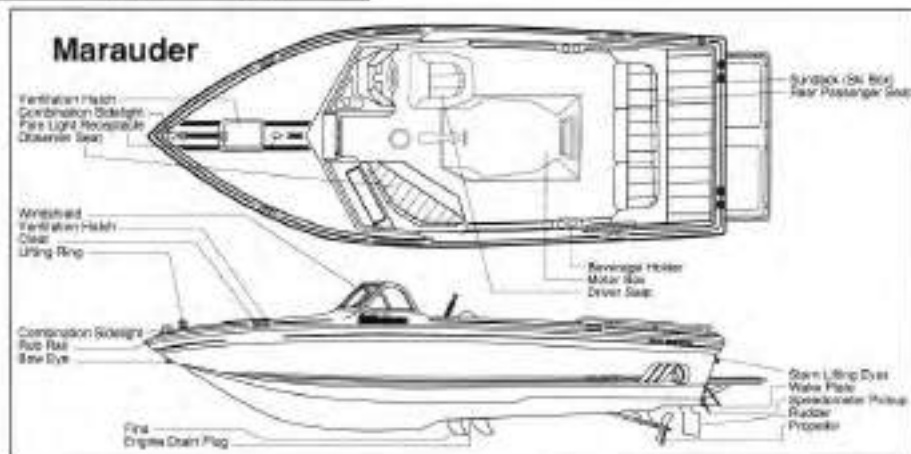

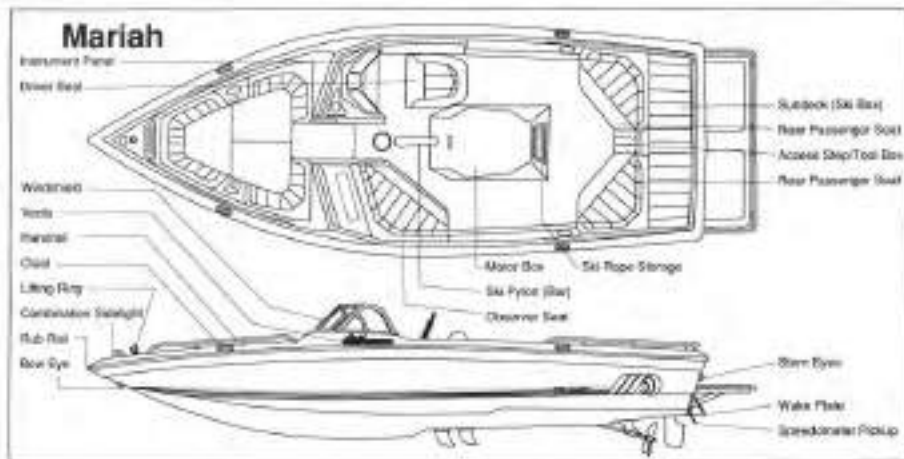

21' Series

Specifications

Length	20'10"
Width (Beam)	95"
Width (Transom)	82"
Draft (At Stop)	20"
Depth (Amidship)	36"
Weight	2,800 lbs.
Fuel Capacity	37 U.S. Gallons
Capacity (Persons)	8

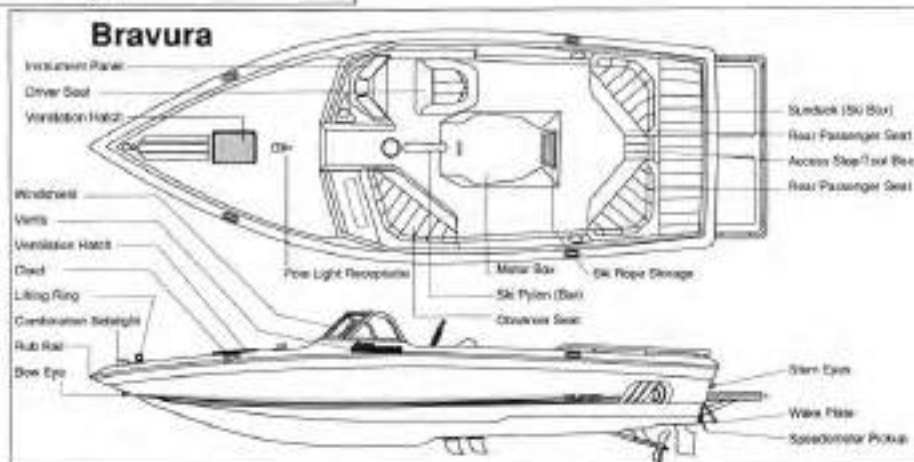



23' Series

Specifications

Length	22'8"
Width (Beam)	99"
Width (Transom)	86"
Draft (At Stop)	25-1/2"
Depth (Amidship)	38"
Weight	3,450 lbs.
Fuel Capacity	46 U.S. Gallons
Capacity (Persons)	10



EXCLUSIVE SUPRATRAC HULL DESIGN

1

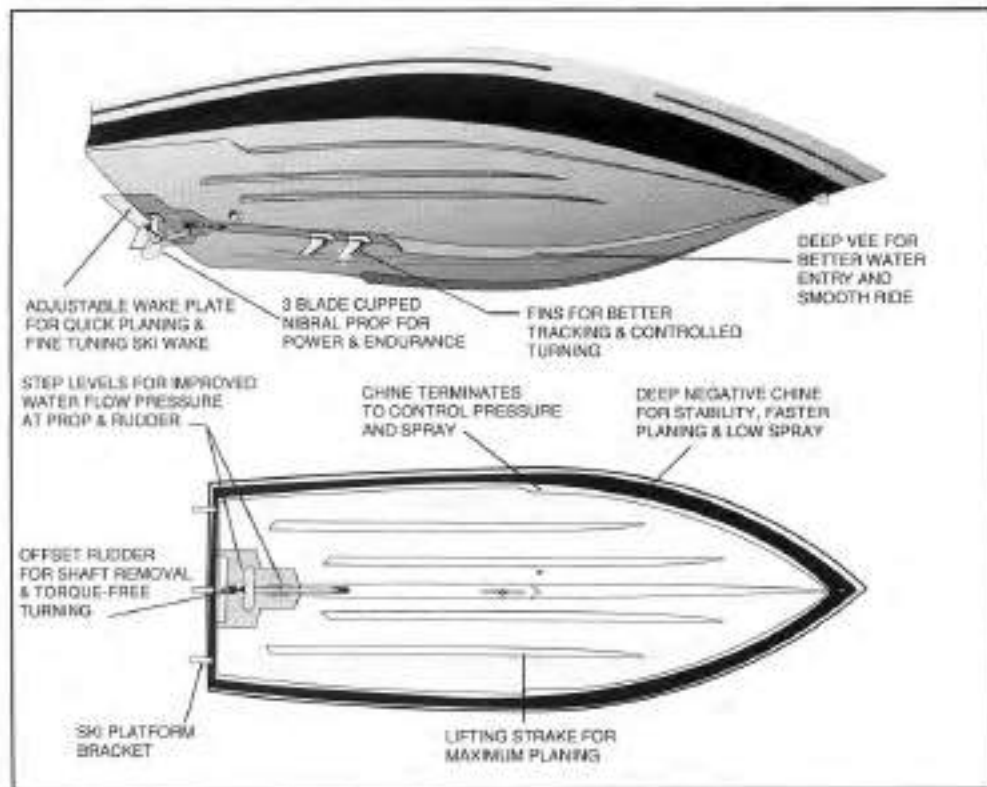

The deep vee and negative chines provide a steep water entry and smooth water flow for high-performance tracking and turning with excellent spray control. The unique Kevlar hull design produces maximum strength with minimum weight. Multi-level steps at prop and rudder insure consistent prop penetration.

FIBERGLASS DETAIL

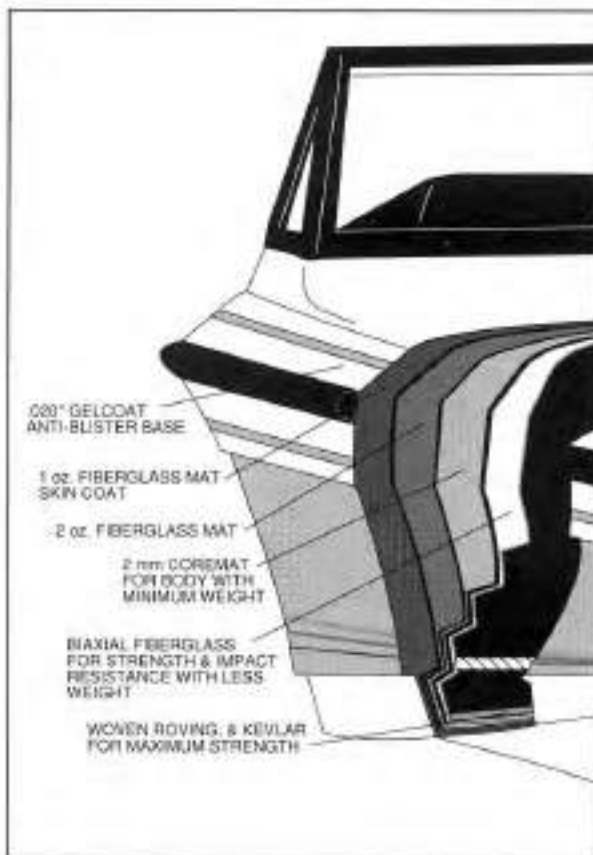

The Supra's smooth, polished finish is the result of its gelcoat and a hand-layered composite of fiberglass. Coremat® and Kevlar® are bonded with AME 4000® resin to produce a strong and durable hull. Supra features unsurpassed performance and handling under the most demanding conditions, and yet the structure is so lightweight it makes Supra a superior class ski boat.

DAILY CHECK LIST

1

BOATMAN'S CHECK LIST

For maximum enjoyment and safety, check each of these items **BEFORE** you start your engine:

- ✓ **DRAIN PLUGS** (Securely in place?)
- ✓ **LIFE-SAVING DEVICES** (One for every person on board?)
- ✓ **STEERING SYSTEM** (Working smoothly and properly?)
- ✓ **FUEL SYSTEM** (Adequate fuel? Leaks? Fumes?)
- ✓ **BATTERY** (Fully charged? Cable terminals clean and tight?)
- ✓ **ENGINE** (In neutral?)
- ✓ **CAPACITY PLATE** (Are you overloaded or overpowered?)
- ✓ **WEATHER CONDITIONS** (Safe to go out?)
- ✓ **ELECTRICAL EQUIPMENT** (Lights, horn, pump, etc.?)
- ✓ **EMERGENCY GEAR** (Fire extinguisher, bailer, paddle, anchor & line, signaling device, tool kit, etc.?)
- ✓ **BILGE PUMP** (Working properly?)

NOTICE: Bilge pump should be checked prior to each use to insure proper operation!

CHECK BEFORE RUNNING

1. Engine oil level.
2. Transmission lubricant level.
3. Engine drain plug, transom drain plug, and center drain plug.
4. Leakage (fuel and water lines and connections).

! CAUTION DO NOT operate engine without cooling water flowing through water pump or water pump will sustain damage, and subsequent engine damage may result.

CHECK WHILE RUNNING

1. Oil pressure of 35-40 psi at 2000 RPM.
2. Water temperature 140° - 160° for raw water systems (water is not recirculated), and 180° - 200° for fresh water systems (water is recirculated).
3. Idle RPM (550 - 600) in gear.
4. Maximum forward 4400 RPM.
5. Shifting linkage (forward, neutral, and reverse).



! WARNING It is very important to check for fuel spillage or leaks prior to each use of your boat.

Gasoline vapors can explode!

Before starting engine:

- Check engine compartment for gasoline vapors.
- Operate blower for 4 minutes.
- Always operate blower below cruising speed.

EQUIPMENT AND OPTIONS

IGNITION KEYS



Two ignition keys are provided with the boat in addition to a special gas key. Key entry into the ignition is difficult at times due to the boot protector. Please do not harshly force the key into the ignition. Key tumblers are located vertically, thus the key should be turned vertically when entering the switch.

GAS KEY



To prevent tampering with the fuel system, Supra provides a locking gas cap which may be opened only by the specially designed key.

FLOATING KEY CHAIN



Always attach the ignition key and gas key to a floating key chain to prevent loss in the water.

DRIVER SEAT

20'



21'



23'



The driver seat may be adjusted forward or backward by moving the lever below the front of the seat. Use body pressure to move the seat to the desired position. Release the lever to lock the seat into place.

NOTICE: The 20' driver seat may also be adjusted to the left or right by loosening the "T" handle below the driver seat and turning the seat to desired position and then retightening the "T" handle to secure the position.

SEAT ADJUSTMENT

20' & 23'

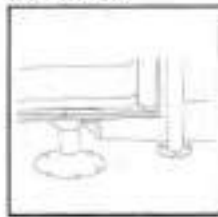

21'



! CAUTION After adjusting the seat to the desired position, be sure the seat latch has locked. This is done by pushing forward and backward with the body.

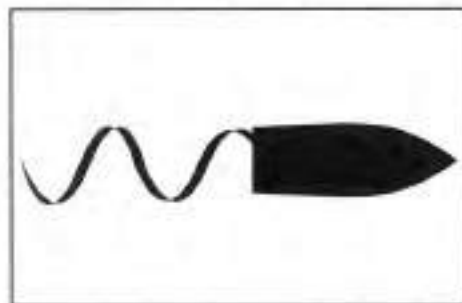

! CAUTION DO NOT attempt to adjust driver seat while boat is moving. Sudden seat movement may cause loss of control over the boat.

MIRROR

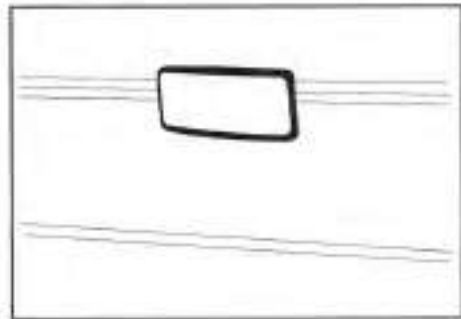

The rear view mirror is installed as a standard item on the windshield. This adjustable mirror is not permanently placed and may be moved or removed.

- Mirror should always be checked before driving.
- Mirror angle will change with each new driver.

FORWARD VIEW

20'

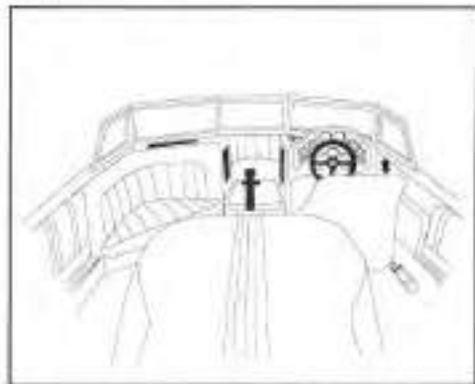

21'

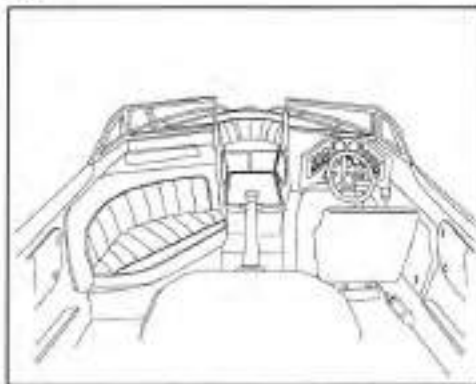

23'

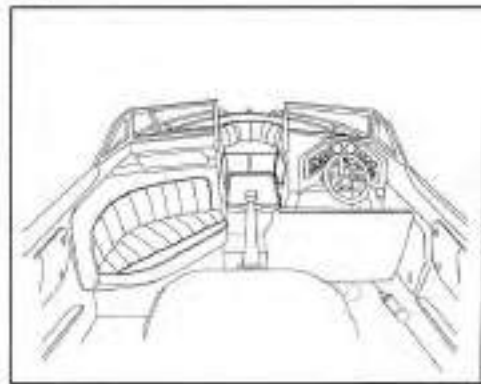

The observer seat, located in the front portion of the boat next to the driver seat, faces the rear of the boat in order to provide a clear view of the skier.

For safety purposes, it is necessary to have an observer on board while pulling a skier to avoid accident or injury.

REAR VIEW

1

20'

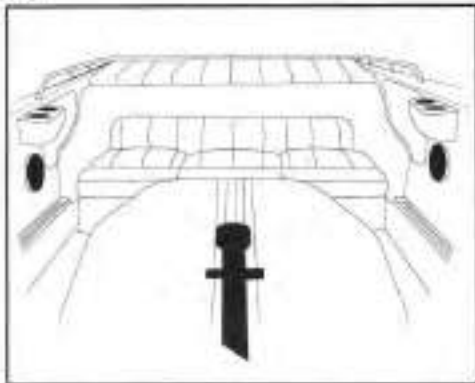

21'

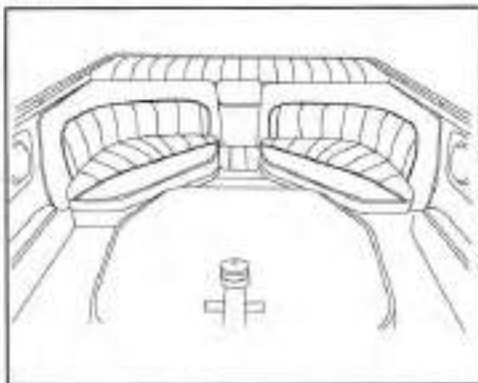

23'

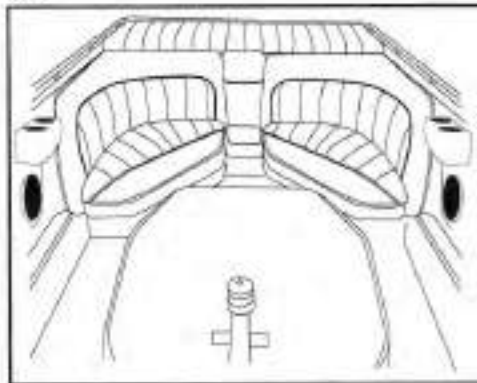

The passenger seat, located at the rear of the boat in front of the ski box, comfortably seats three persons.

It is recommended that the vinyl upholstery be kept dry. Slide seat cushions out approximately 1" to allow air to circulate behind and underneath them when boating session is over.

WALK-THRU WINDSHIELD

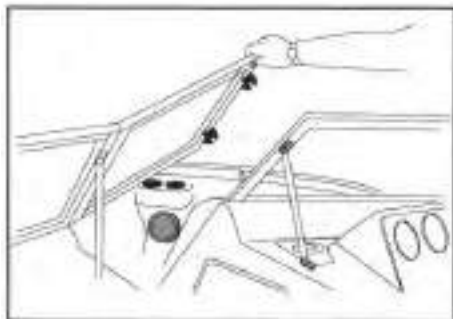

Supra boats with open bow designs are equipped with a movable center windshield panel to provide access to the bow seating and storage.

To open, turn safety latches to a vertical position and push out. Lay center windshield panel gently back against the port side fixed windshield.

NOTICE: Windshield should remain closed and locked while boat is in transit.

20' & 23' BATTERY BOX

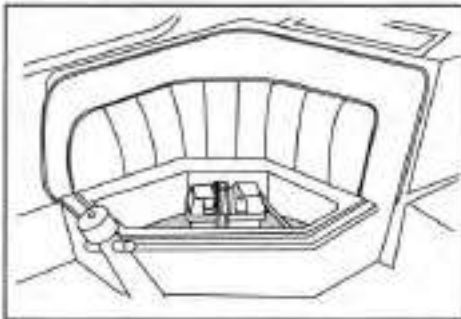

The battery box is securely mounted under the observer seat cushion for easy access.

NOTICE: It is recommended that the battery cables be removed from the battery when the boat is in transit, on display, or placed in storage.

(Refer to Battery Cable Installation and Precautions in Chapter 3.)

21' BATTERY BOX

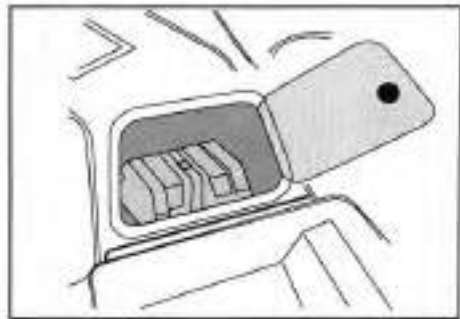

The battery box is securely mounted inside the port side storage area in the walk-thru.

MOTOR BOX

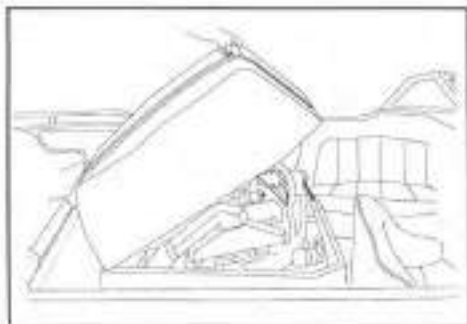

The motor box provides required protection and quiets noise transmitted to the passengers on board. To open, stand on either the right or the left side of the box toward the stern of the boat.

Grasp handle and pull up at approximately a 45° angle. The motor box will raise up so that engine inspections may be made easily. If the engine requires any repair work, tilt the motor box open until it stays open on its own.

PULLEY WARNING



! WARNING Pulleys and belts can cause severe injury. Never open motor box while engine is running or while boat is moving!

Remember that, after running the boat, the engine is extremely hot and should not be repaired until it has cooled down completely.

MOTOR BOX STORAGE

1

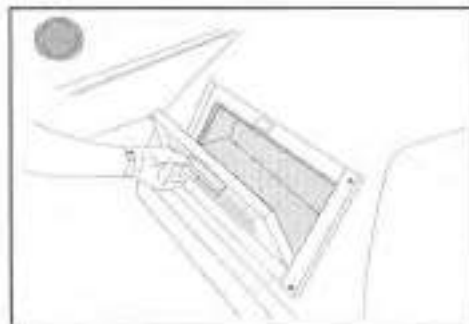

The storage box, surrounded by a teak frame door and handle, is located at the back of the motor box. This space may be used for storage of ski equipment or other items on board. Follow the teak care instructions prescribed in this manual.

NOTICE: Models with plenum chamber boxes will not have storage compartment or teak door.

FRONT STORAGE



A storage compartment is located on either side of the walk-thru. These compartments are easily accessible to the driver and passengers on board. They may be used for storing cassette tapes, maps, the owner's manual, etc.

20' & 23' ENTRANCE DOORS



The cabin section of the 20' and 23' closed bow model is enclosed by plexiglass entrance doors. The top consists of two pieces of plexiglass joined together by hinges.

To open, lift top section and fold under, then gently pull hinged entrance doors open and secure by snapping vinyl strip on the walk-way to the door.

21' ENTRANCE DOOR



The 21' closed bow is enclosed by a single plexiglass door. To open, turn knob and pull out. The door may be held in an open position by snapping vinyl strip on the walk-way to the snap on the door.

NOTICE: Due to the low ceiling height, use caution when entering or exiting the cabin.

SKI LOCKER

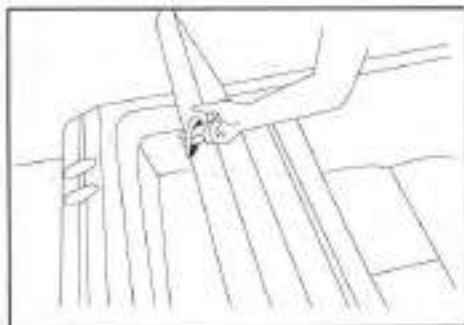

The ski locker, conveniently located at the rear of the boat, offers adequate space for all skiing equipment.

The ski locker opens by grasping the pull-strap and pulling up and back toward the front of the boat.

The louvered plates located at the bottom of the ski locker provide easy access to the fuel tank components.

SUN DECK

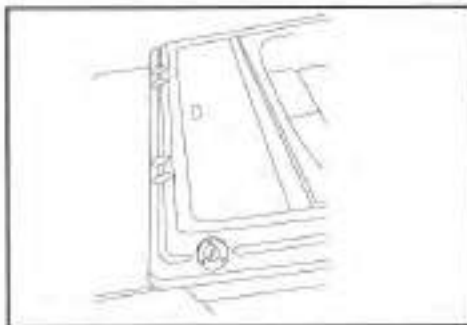

When the ski locker is closed, it doubles as a cushioned sun deck.

VENTILATION HATCH

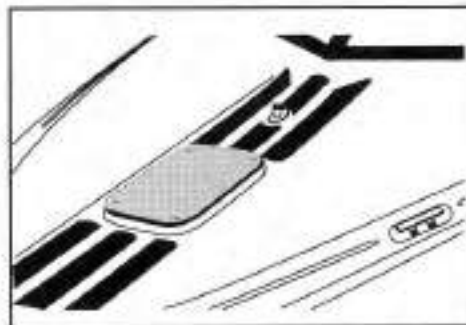

The closed-bow model is equipped with a ventilation hatch as standard equipment.

23' ROPE LOCKER

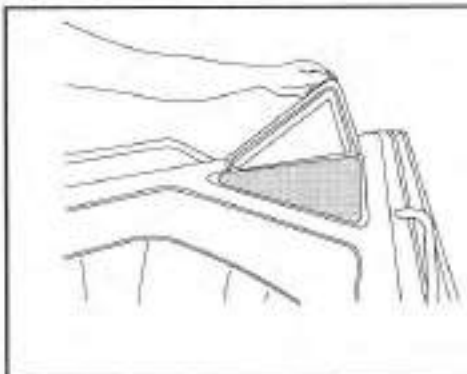

A rope locker is installed on the 23' open-bow model as standard equipment. This area provides adequate storage space for rope, or other marine equipment.

! CAUTION To avoid personal injury, keep the top closed at all times while the boat is in motion.

TILT STEERING



Tilt steering may be adjusted up or down 48 degrees in five different locking positions. To adjust, simply depress the tilt lever located beneath the steering helm and move steering wheel to desired location. Release the tilt lever and the tilt steering will lock into place.

DRIVER STORAGE AREA



The driver storage area, located to the right of the driver seat in the footwell, provides adequate storage for valuables or other small items on board.

QUARTER WINDOW VENT

1

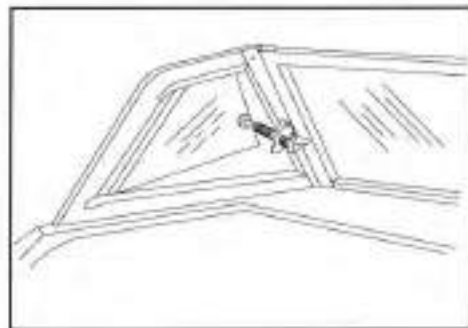

Quarter window vents may be adjusted by the following procedure:

- Lift the "T" handle out of its housing very gently.
- Push the vent out to the desired opening.
- Gently twist "T" handle to maintain selected open position.
- Push the "T" handle back into place.
- Check to be sure the vent is secured in place.

NOTICE: DO NOT leave the quarter window vent open while the boat is being trailered as this may exceed the legal trailerable width limit of the boat.

20' & 23' BEVERAGE COOLER



The beverage cooler rises in the center of the walk-thru passage. Its 11-gallon capacity is storage for a Coleman cooler and both are heavily insulated to avoid heat transfer, providing adequate space for various beverages and other items to be chilled.

To access, grasp cooler cushion and pull up. The entire cushion may be removed as the cushion is not hinged.

21' FRONT SKI STORAGE



To access the forward ski storage area, simply grasp cushion in the center of the walk-thru and lift. The area may be used for ski storage, ropes, personal flotation devices, etc.

BOW STORAGE 20'

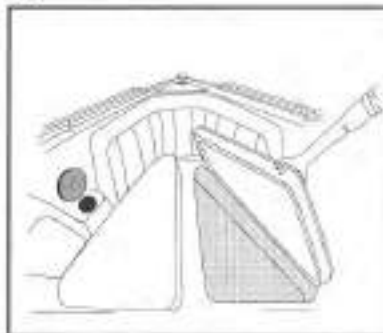

All Supra open bow models provide a carpeted storage area beneath the seat cushions for ski vests, flotation devices, ropes, and other items.

To access storage, grasp cushion and pull upward.
To close cushions properly:

- Align cushions above storage compartment until sides touch.
- Raise center line of cushions slightly and gently push cushions downward simultaneously.

21' & 23'

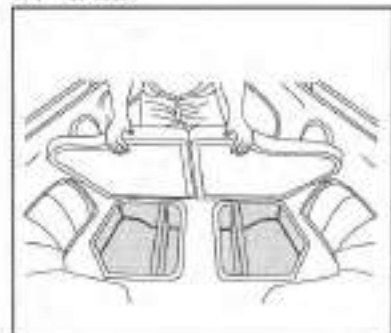

21' BOW SKI STORAGE ACCESS

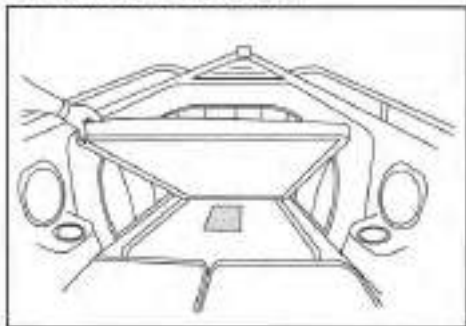

The small opening under the front bow seat cushion allows access to the forwardmost part of the ski storage area.

CABIN STORAGE BOX 23'

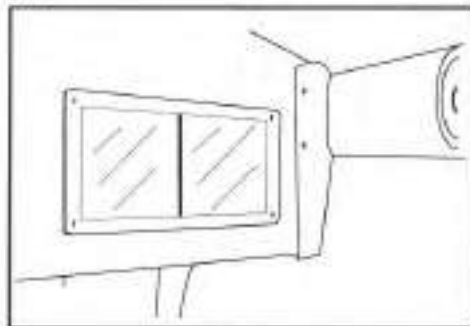

Another storage compartment is located on the port side of the cabin section. This compartment is accessed by sliding the mirror doors to port or starboard.

BULKHEAD MIRROR 23'

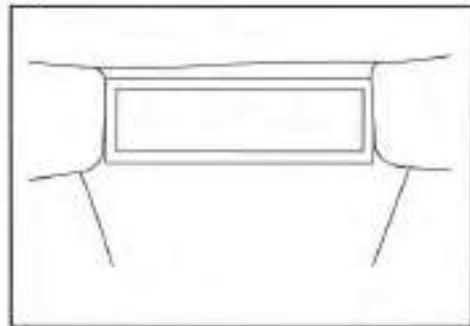

The bulkhead mirror is a standard item on the 23' closed bow model.

DOME LIGHT

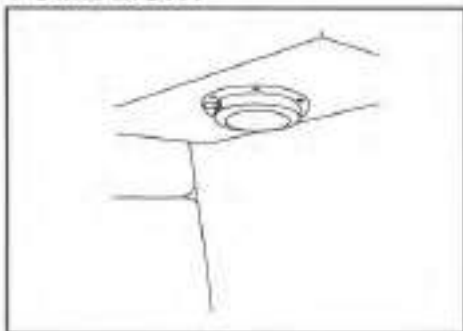

A dome light is installed in the cabin section and receives power from the "ACCES" breaker switch on the dash panel. To turn dome light "ON" or "OFF", simply flip the switch.

PORT DASH AREA



The wet bar is located behind the observer seat as a factory installed option. The bar assembly consists of a fiberglass liner, black plexiglass well, and a plexiglass bar top with handle. The wet bar is capable of holding up to four glasses, two bottles, and an ice bucket.

To open wet bar, grasp handle and pull upward gently.

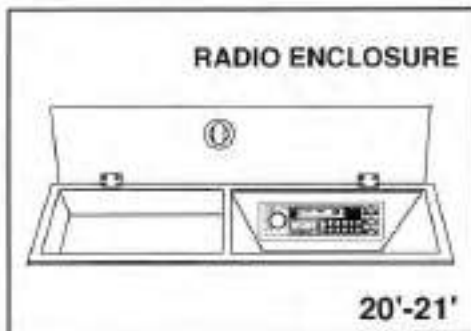

The radio enclosure protects the radio from the elements. It can also be used to store small items such as cassette tapes and sunglasses. The enclosure is located on the port side dashboard.

FOOT STEP

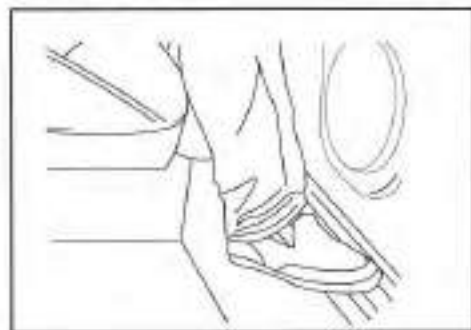

Two teak foot steps are conveniently located at the center of the boat on the port and starboard sides. Use them when loading and unloading passengers at the dock.

! CAUTION: Use caution when using the steps. They may become slippery when wet.

BOW LIGHT

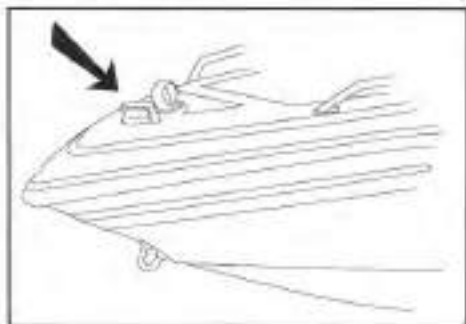

The bow light is located at the very tip of the bow near the lifting ring. The light is divided into two colors: green and red. Green signifies the starboard side and red the port side. The purpose is to alert oncoming boats. The color signifies the side on which the oncoming boat should pass.

STERN LIGHT

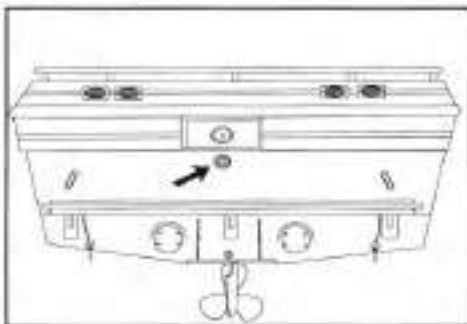

The stern light is located at the center of the transom below the ski tow ring. The purpose is to alert boats approaching from behind.

POLE LIGHT



The removable pole light is stored on the side wall of the rear ski storage area. Gently pull pole light from wall clips and place light into the pole light receptacle.

Pole light must always be in place and illuminated when visibility is a problem.

Pole light must be displayed while under way from sunset to sunrise.

POLE LIGHT RECEPTACLE



The pole light receptacle is located on the starboard side in front of the driver's windshield on the open bow models and centered in front of the windshield on the closed bow models. To install pole light, unscrew black cap on receptacle. Slide pole light into receptacle so that circuit prongs line up correctly. Secure pole light by screwing lock nut onto receptacle.

COURTESY LIGHT

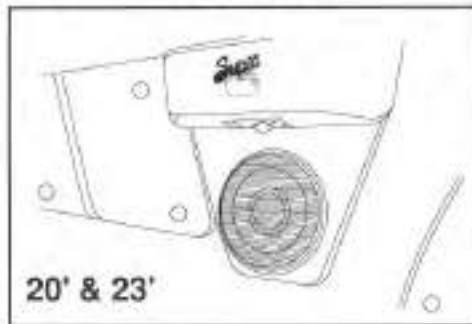

The courtesy lights are located below the observer seat and the rear seats. Courtesy lights may be used for map reading or as a guide light while boating at night. The switch for the courtesy lights is located on the starboard dash panel marked "COURT",

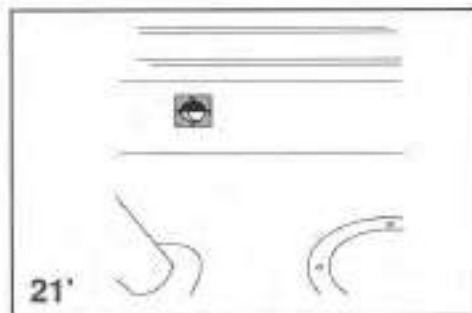

LIFTING RINGS

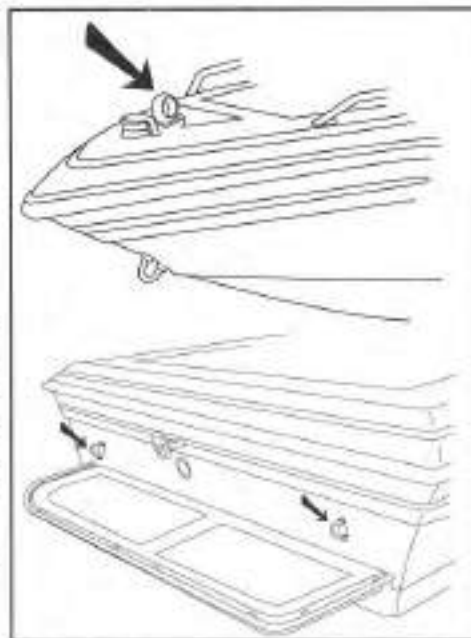

The lifting rings are located at the tip of the bow section and at both sides of the transom.

The lifting rings shall be the only means by which the boat is hoisted.

(See dry storage and hoisting instructions.)

REAR PASSENGER SEAT COMPARTMENT

23'

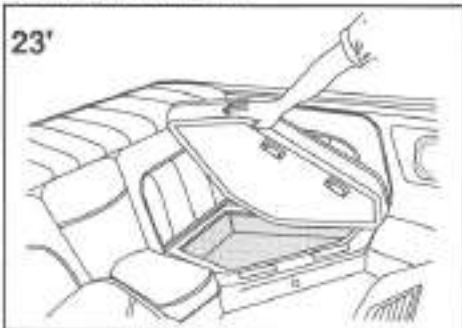

Two storage compartments are available beneath the two rear passenger seat cushions. In addition, there is more storage located under the center cushion on the 23' Series and an access step/tool box on the 21' Series Supra.

21'

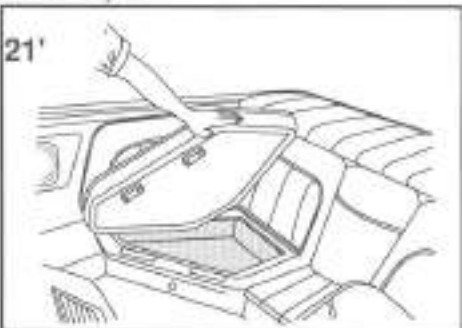

ACCESS STEP/TOOL BOX

21'

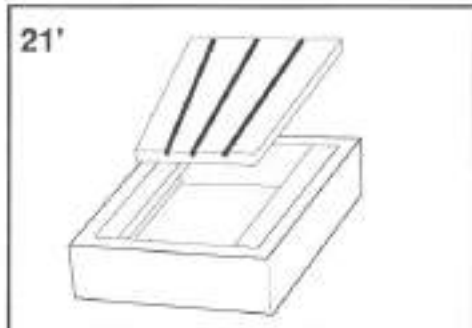

The access step/tool box is another storage area located between the rear passenger seats. Tools should be wrapped with oil cloth and placed in a plastic zip-lock storage bag before placing in the tool box.

NOTICE: Remove all tools before prolonged storage.

JUMP SEAT

23'



The jump seat is located in the center of the rear passenger seating area and can be used for additional seating and storage of small items.

BOW EYE

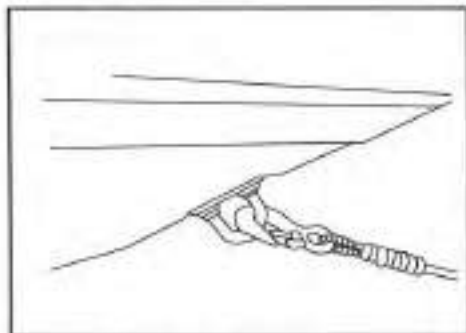

The bow eye is located toward the front section of the hull. Its primary functions are to lead the boat onto the trailer and to secure the boat at the dock.



NOTICE: DO NOT use the bow eye to hoist the boat. Use the designated lifting rings on the deck to hoist the boat.

(Please refer to Chapter 2 for correct hoisting instructions.)

BILGE INSPECTION PLATE

1

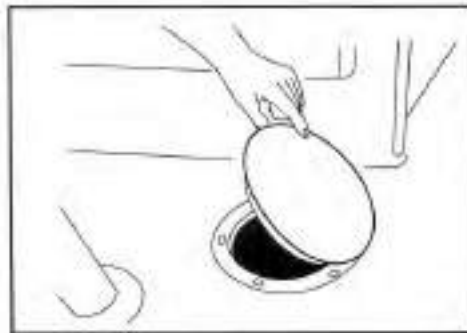

The bilge area inspection plate is located in front of and to the right of the ski bar. It enables you to check the condition of the bilge area and to remove built-up foreign matter and debris.

Gently pry open the inspection plate using a flathead screwdriver or similar tool. A small notch in the inspection plate indicates where to place the screwdriver.

NOTICE: Keep bilge area clean and filtered from dirt and debris.

FUEL TANK

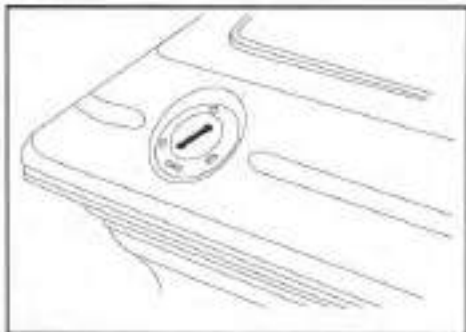

The fuel cap is located on the starboard side of the boat near the transom. A specially designed fuel key has been provided to open the cap.

FILLING THE FUEL TANK

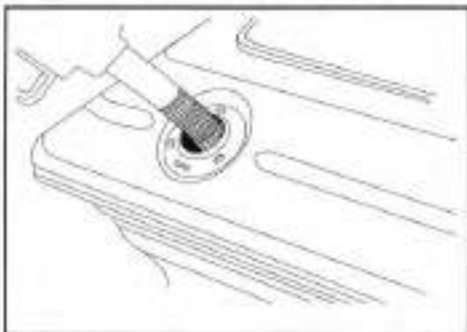

NOTICE: Pay careful attention when filling the fuel tank. **DO NOT** overfill the tank! Fuel may exit through fuel vent and damage to striping may result if immediate action is not taken.

If fuel does spill on stripes, apply a common bath cleaner and wipe with a damp cloth. Rinse area with clean water.

FUEL PRECAUTIONS

1



! WARNING Sparks while fueling can cause an explosion!

BEFORE FUELING:

1. Turn off engine.
2. Turn off all electrical systems.
3. Extinguish cigarettes or any open flames.

WHILE FUELING:

1. Keep hose nozzle in contact with fill pipe to provide a ground against static sparks.
2. Fill tank at a slow rate to avoid any spillage.

FUEL VENT

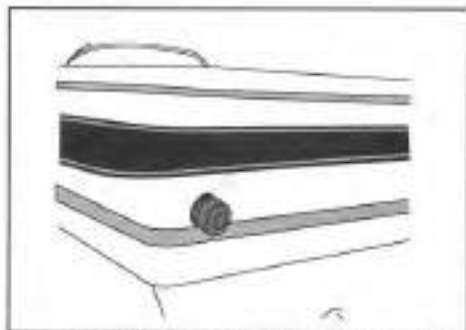

The fuel vent is located on the port side of the transom. It is connected to the fuel tank via the vent hose to release gasoline fumes from the fuel tank.

! CAUTION To clean or inspect, simply unscrew the cap on the vent, clean and replace. Gasoline vapors are highly explosive.

FIRE EXTINGUISHER

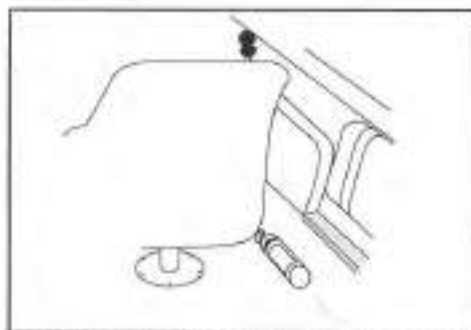

A standard Coast Guard approved fire extinguisher is provided on all Supra boats. The fire extinguisher is located on the starboard side of the boat behind the driver seat.

(Refer to label instructions for operating procedures.)

BEVERAGE HOLDERS

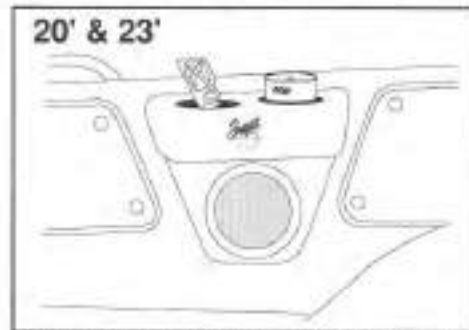

Beverage holders are located in a variety of places throughout the Supra. The holders provide a secure place for beverage cans and may also be used for temporary storage of small items such as keys, coins, or glasses. Keep the lakes and waterways clean. **DO NOT LITTER.**

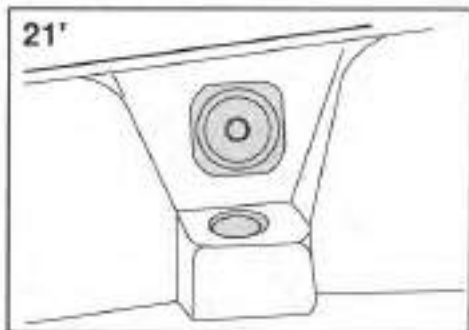

RUB RAIL

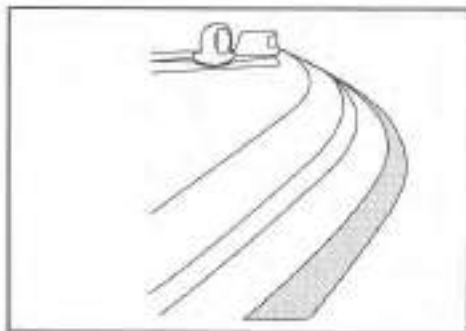

The black rubber rub rail surrounds the edge of the boat deck to protect it from minor damage which may occur during docking or encounters with other boats.

WAKE PLATE

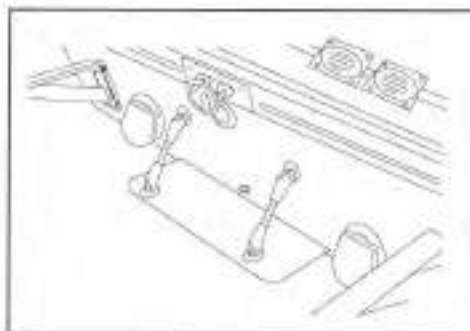

All Supras are equipped with a wake plate which is located at the bottom of the transom. Proper adjustment of the wake plate will allow better control of the longitudinal trim.

Adjustment is made by turning the turn buckles to the desired position, thus moving the wake plate up or down.

The wake plate should be in the horizontal position for slalom skiing.

Raise the plate 1/2" above the horizontal plane for trick and barefoot skiing.

PROPELLER PRECAUTION

1



! DANGER Moving propeller will cause injury. Propeller may turn with boat in neutral. Shut off engine while adjusting wake plate! **DO NOT** attempt to adjust the wake plate while the engine is running or use the plate as a loading platform.

NOTICE: **DO NOT** lower the wake plate below the horizontal plane or raise it over 1/2".

SPEEDOMETER PICKUPS

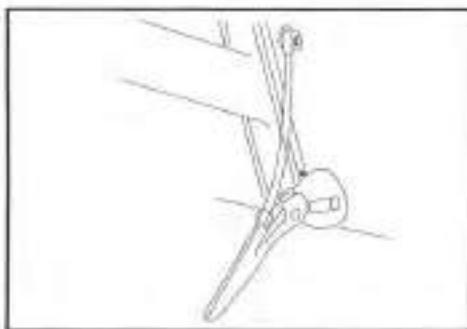

The speedometer tube pickups are located at the stern of the Supra. These pickups are the means by which the speed of the Supra is measured. Poor water conditions or foreign objects may clog the pickup hole, thus causing the speedometer to register speed incorrectly.

If the speedometer does not respond after stopping and restarting the engine, inspect tube pickups and clean out any foreign objects. A small wire may be inserted into the tube to clear it out.

Supra

The speedometer pickups may pivot 45° off the down position during hard turning and trailering. At this time, the pickups will register a partial speed.

Before unloading or motoring the boat, be sure the pickups are in proper position. While trailering, the pickups should be adjusted to the up position to relieve air pressure from the system.

CLEATS

1

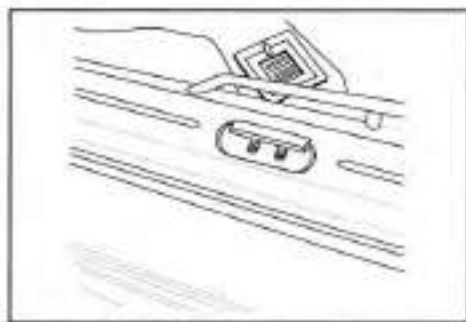

There are cleats on each side of this model of Supra boat. Use the cleats to secure the boat to the dock any time the boat is left unattended.

NOTE: Cleats are designed only for docking purposes and should never be used for hoisting or trailering the boat.

SKI PLATFORM

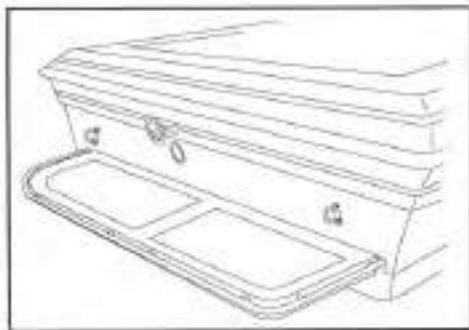

All Supra boats provide a ski platform at the stern of the boat. The primary function is to provide easy access into and out of the water for skiers and swimmers.

It is recommended that all entries to and exits from the water are made from the platform so as to avoid any unforeseen accidents. (The fiberglass deck can become slippery when wet).

PROPELLER PRECAUTION

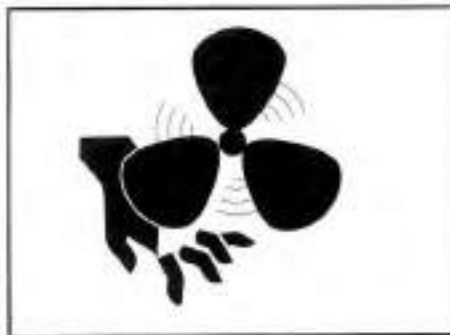

! DANGER Moving propeller will cause injury. Propeller may turn with boat in neutral. Shut off engine when people are on the platform or in the water near the platform.

DETACHABLE BRACKET

1

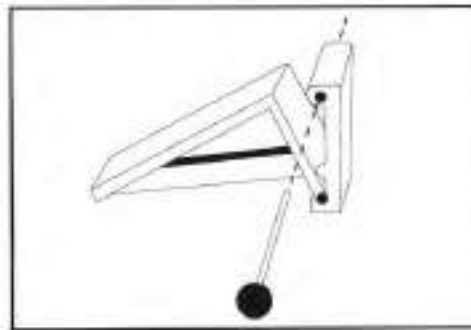

The ski platform is attached to the boat by detachable brackets so that the platform may be removed by simply pulling the pins.

PROPELLER

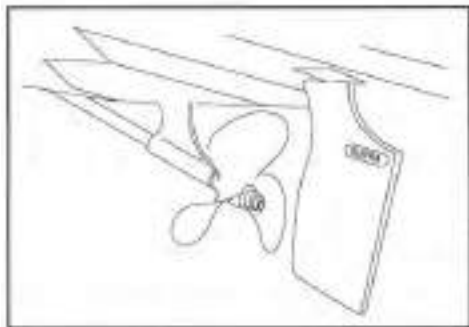

The research and design team at Supra has carefully explored and tested several different types of propeller designs and pitch angles. All tests have indicated that the current propeller equipped on the Supra is the best suited for the variety of boating needs required, ranging from competition skiing to a relaxing leisurely ride.

It is highly recommended that if any propeller change is to occur, the Supra dealer is notified.

In general, changing the factory propeller to a low pitched propeller will increase acceleration and load ability, but will slightly decrease top speed.

Changing the factory propeller to a high pitched propeller may achieve higher top speed with a light load, while quick acceleration and power may decrease.

NOTICE: Under no circumstances should a propeller which allows the engine to surpass recommended RPMs be used.

SKI PYLON (BAR)

1

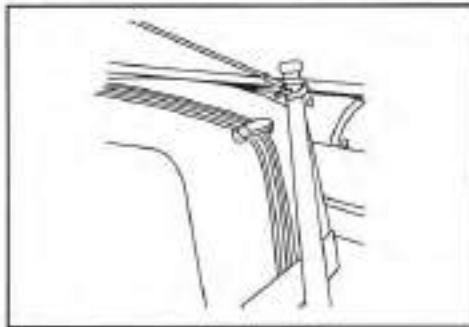

The ski bar is located in the center portion of the boat directly in front of the motor box.

The ski bar is to be used to pull skiers. **DO NOT use ski bar to hoist boat.** Use the lifting rings for this purpose.

INSTRUMENTATION PANEL AND CONTROLS

1

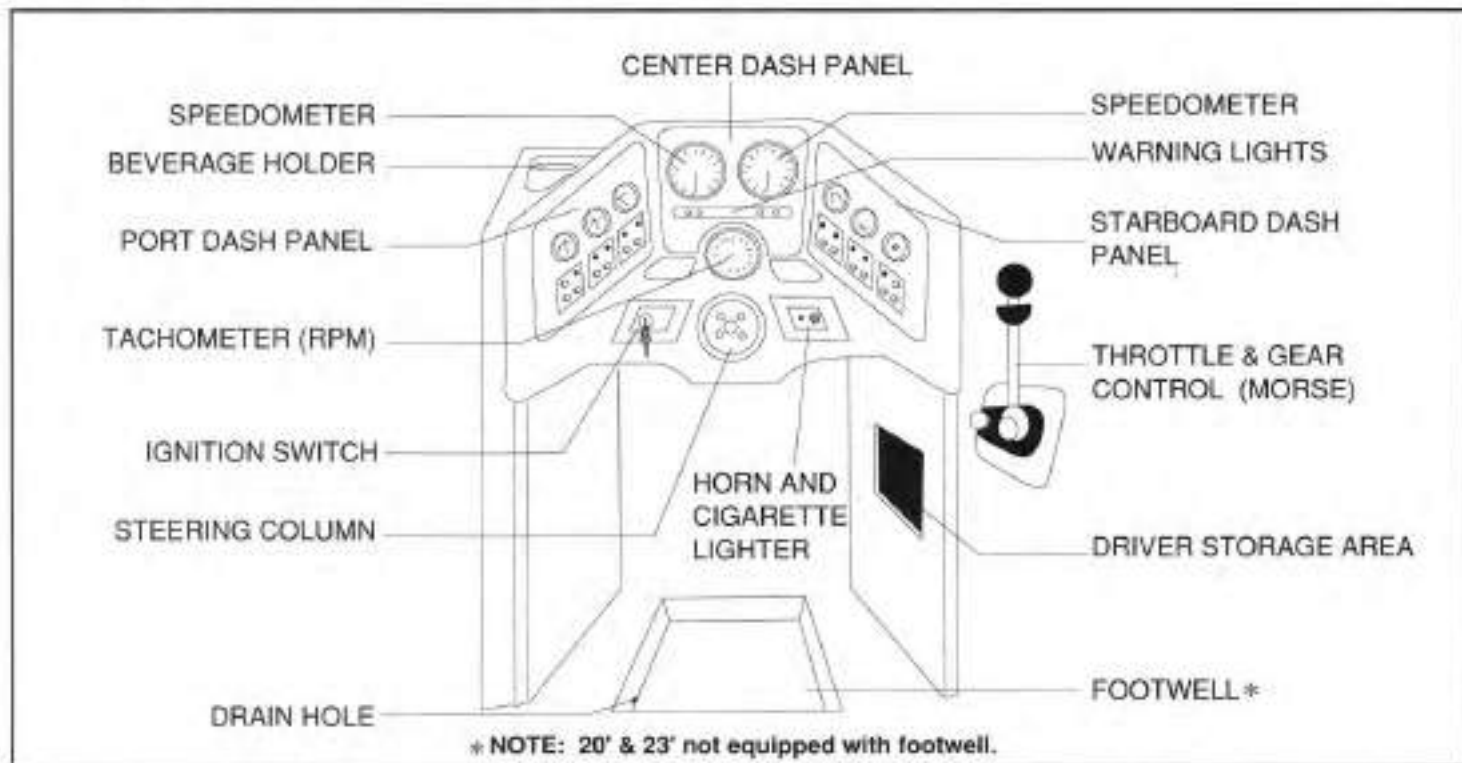

SPEEDOMETER

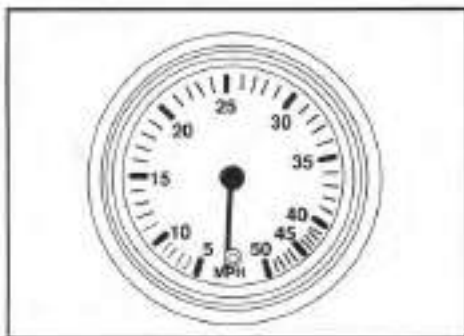

The speedometer indicates the accurate water speed of the boat in miles per hour. It is recommended that, after 100 engine hours, the speedometer is checked by a stopwatch and slalom course.

If speeds are not accurate, adjust the speedometer needle by turning knob at bottom of gauge.

SLALOM COURSE SPEEDS:

MPH	TIME/SECS	ALLOWABLE TIMES / SEC + / - 1/2 MPH
30	19.3	19.0 - 19.6
32	18.1	17.9 - 18.3
34	17.0	16.8 - 17.2
36	16.1	15.9 - 16.3

TACHOMETER

1

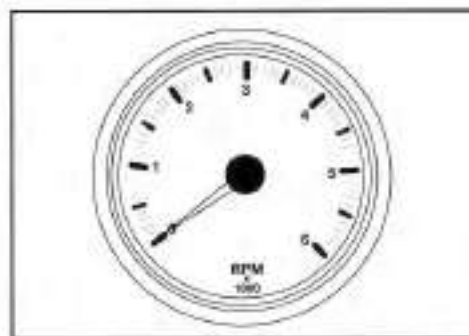

The tachometer registers the operating speed of the motor's shaft output in revolutions per minute. This output may be used as an alternative to a speedometer if weight and water conditions permit.

- **DO NOT** exceed the recommended RPM during break-in and normal operation of your motor. Exceeding the suggested RPM may cause damage to the engine.
- During tune-up and maintenance, use a dwell meter and RPM gauge to verify the dash RPM when setting your engine's idle speed.

THROTTLE LEVER



The throttle lever, located to the right of the instrument panel, disengages the transmission by pulling out the button in front of the lever. This places the transmission in neutral and gives the throttle full range. Position the throttle vertically (in idle) before re-engaging transmission by depressing the button.

- When engaging transmission from neutral to forward or reverse, lift the safety lockout and move the lever slowly.

- Never shift the lever directly from the vertical (neutral) position into a speed position.

- To prevent high torque engagement damage to transmission, slowly shift the lever into gear allowing transmission to engage, then accelerate the engine.

- Once the transmission is engaged, you may accelerate as quickly as you like.

NOTICE: NEVER operate engine with tachometer needle indicating over 4400 RPM. Continued operation at this speed may result in serious engine damage.

MORSE LOCK OUT

1

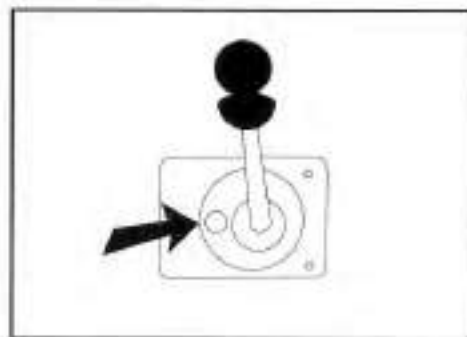

Morse lock out must be depressed to engage transmission from forward to reverse.

PORT DASH PANEL

1

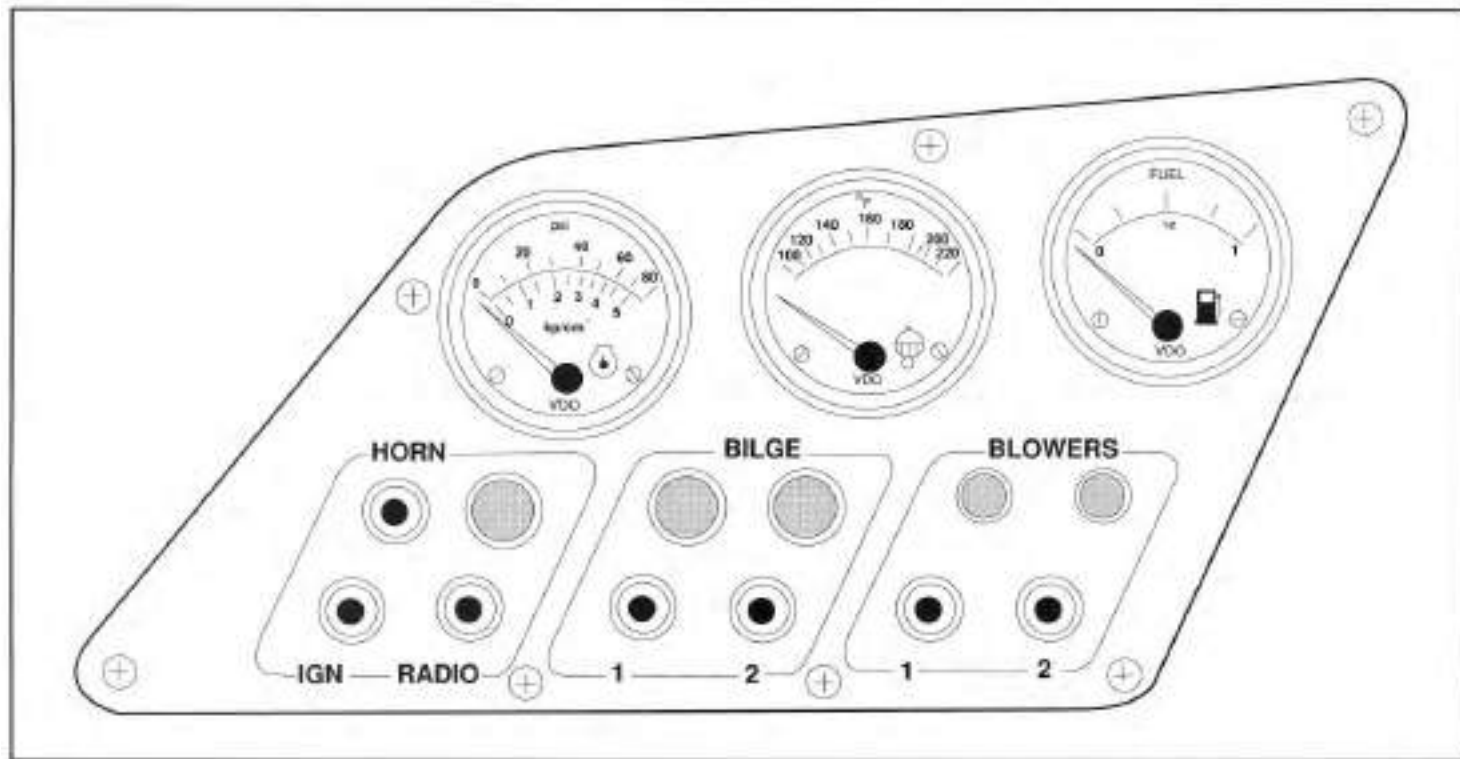

IGNITION

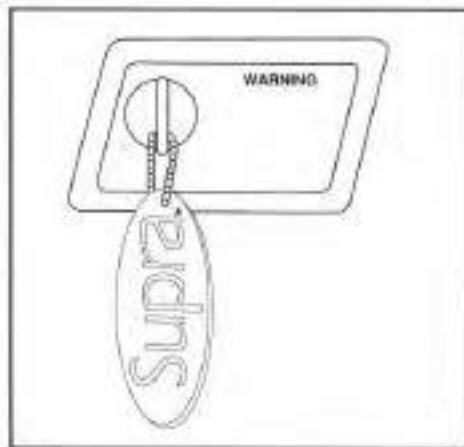

Located on the port side of the dash, the ignition switch has a two-position function.

Turn ignition to the right to check all electrical equipment, including blower, pumps, and lights.

Turn ignition all the way to the right to start the engine.

OIL PRESSURE GAUGE



The oil pressure gauge indicates the oil pressure in the engine while the engine is running.

If the oil pressure remains below the normal range of 20-40 p.s.i., stop the engine immediately. If engine continues to run while oil pressure is low, permanent engine damage may occur.

DIPSTICK



NOTICE: The oil pressure varies greatly with engine temperatures and speed. If oil pressure indication is too high or too low and will not increase when engine speed is increased, stop the engine immediately and check level of oil in engine using the level dipstick.

NOTICE: Continued engine operation while oil level is not normal may result in serious engine damage. Have the engine lubricating system checked as soon as possible by your Supra dealer.

TEMPERATURE GAUGE



The temperature gauge indicates the engine coolant temperature while the coolant is circulating inside the engine. Engine operating temperature will vary depending on weather conditions and engine load.

- If the engine temperature reaches the overheating range, a sensor will sound as a warning of potential trouble.
- If the sensor does sound, stop the boat immediately and allow the engine to cool. Check coolant system after engine is cold or have engine checked by a service mechanic.

FUEL GAUGE

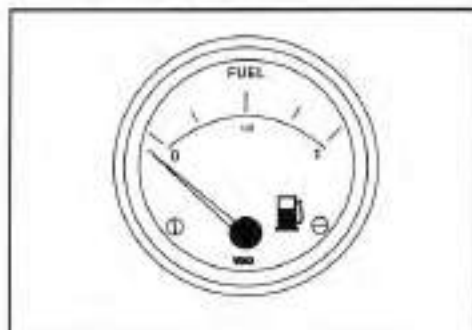

This gauge indicates the approximate quantity of fuel remaining in the tank when the ignition is in the "on" position.

- When the fuel level is below 1/4 tank, a warning light will appear.

NOTICE: DO NOT run the tank to empty. To prevent condensation from forming in the tank, it is recommended that the tank be filled when the gauge indicates 1/4 tank.

The following conditions may be considered normal operation of the fuel gauge and fuel system.

- Gas station pumps may shut off before the fuel gauge indicates 1 (FULL).
- The amount of fuel required for fill-up may not exactly correspond to the gauge.
- The needle may not move away from 1 (FULL) until some time after fill-up.
- The needle may move during turns, stops, and accelerations.

NOTICE: Become familiar with engine hourly fuel consumption at various speeds and use as a backup check against fuel gauge readings.

ELECTRICAL DISCONNECT SWITCH

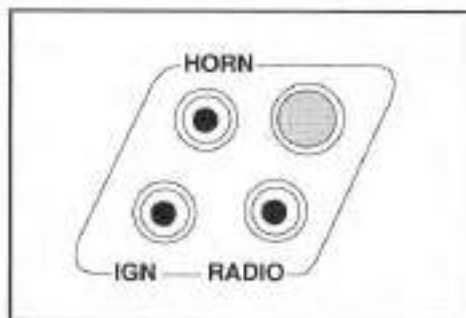

Located on the upper port side control panel, the electrical disconnect switch deactivates all electrical equipment on board except the auto bilge pump function. This includes all instrumentation and lighting.

* All electrical equipment should be turned off when boat is in storage.

BILGE PUMP SWITCHES

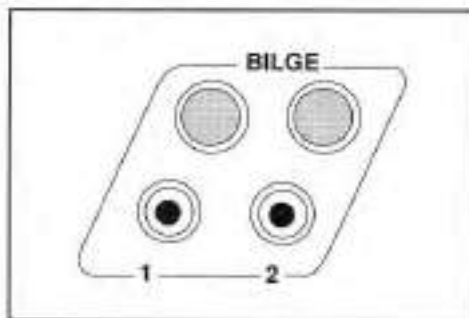

Two pump switches are supplied.

The manual testing switch 1 is used to determine if the bilge pump motor is operating correctly.

If the bilge pump is working properly, the auto bilge pump function is engaged at all times so that any excess water in the bilge area may be drained out.

The number 2 switch is for an additional pump to be installed if so desired.

BLOWER SWITCHES

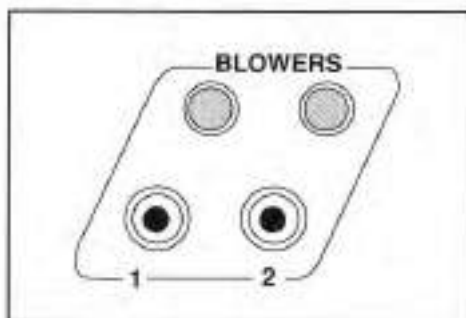

The blower switches activate two blower motors located near the engine and transom of the boat. The primary function of the blower is to eliminate any fumes in the bilge area and to supply a constant supply of fresh air to the engine.

Never depend solely on the blower to eliminate dangerous fumes. Always open motor box to check if fumes are present.

Turn blower switches on a minimum of four minutes and check engine compartment before starting engine.

WARNING: DO NOT operate blower when refueling.

WARNING BOX

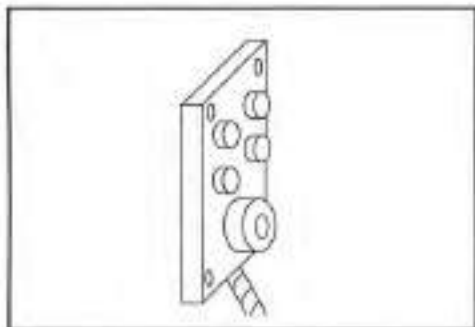

To insure that immediate attention is given when any abnormal indications are measured by the instrument gauges, Supra has provided an early warning system which will sound an alarm and indicate which system is malfunctioning.

The Warning Box is located under the starboard dash panel.

NOTICE: If the buzzer or lights activate improperly, the boat should be taken to your Supra Dealer for adjustment.

WARNING LIGHTS

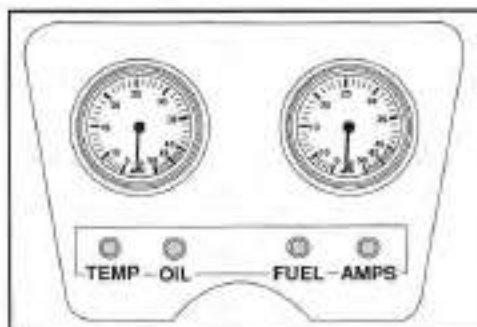

Located on the center of the instrument panel are four warning lights which will illuminate if any system is not operating properly.

- If oil pressure is too low, the oil light will be illuminated and the alarm will sound.
- If engine temperatures are too high, the temp light will be illuminated and the alarm will sound.
- If voltage becomes too low or too high, the amps light will be illuminated and the alarm will sound.
- If fuel level becomes too low, the fuel light will be illuminated and an alarm will sound.

NOTICE: When engine is initially started, an alarm will sound indicating low oil pressure and low voltage. This should only last a few seconds until pressure and voltage are built up within the engine.

NOTICE: DO NOT disconnect warning buzzer. Doing so will discontinue the electrical warranty.

NOTICE: Gauge readings should be maintained during operation to insure all systems are operating properly.

STARBOARD DASH PANEL

1

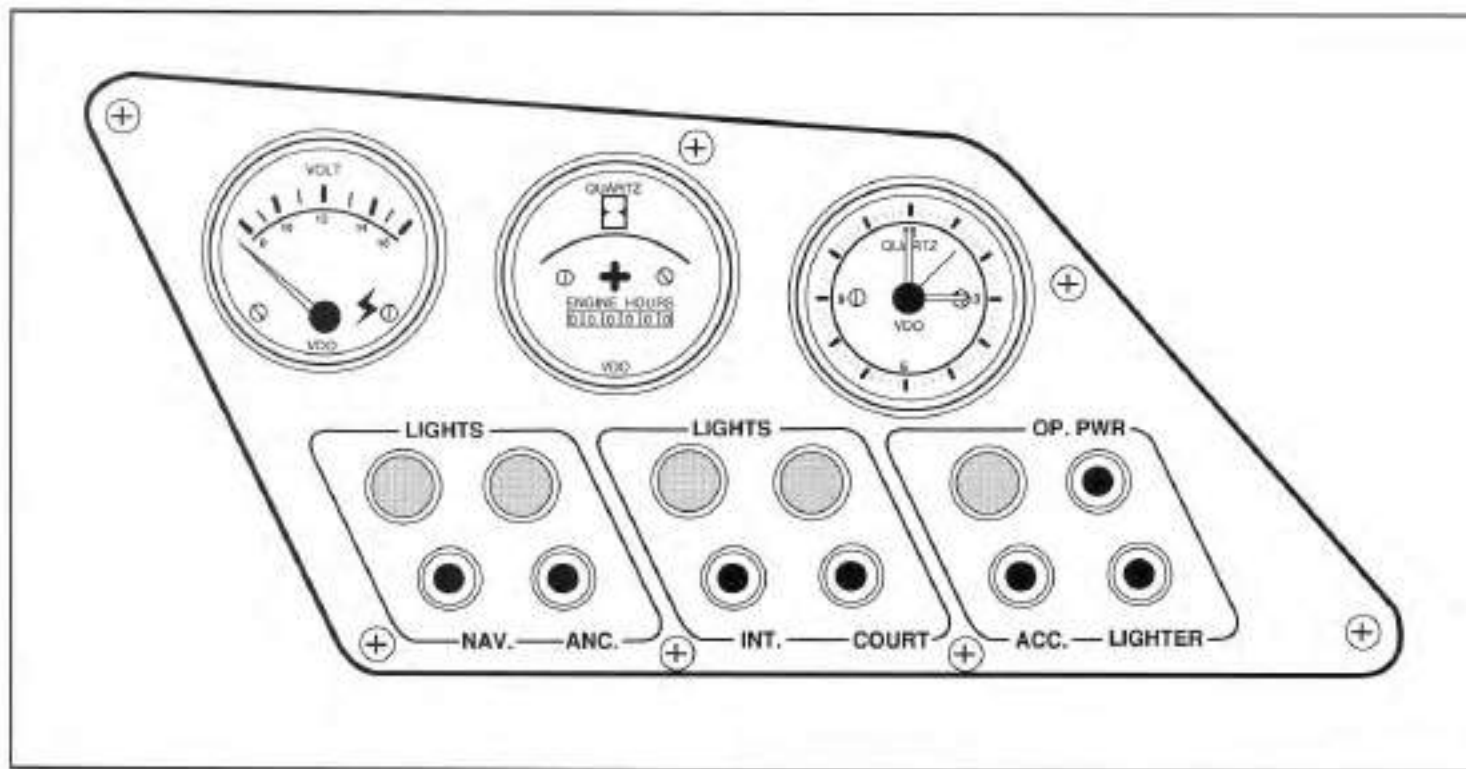

VOLTMETER

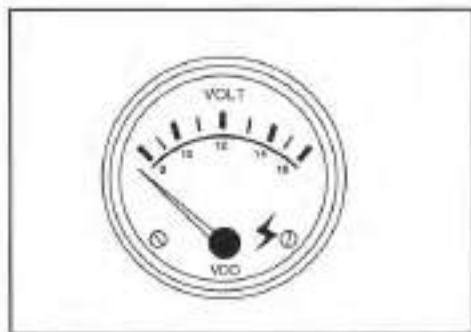

The voltmeter indicates whether the battery is charging or discharging. The needle should be located in the normal range while the engine is running.

If the voltmeter does not register in the normal range, there may be a problem within the electrical system.

It is normal for the voltmeter needle to fall below the normal range while starting the engine. Normal range is 12-14 volts.

ENGINE HOURS

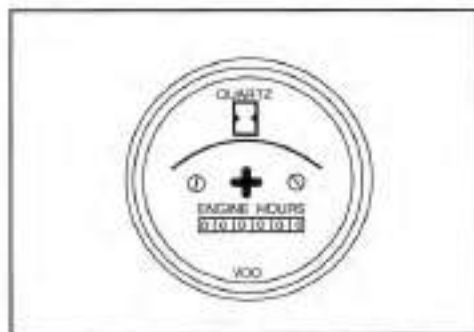

The engine hour gauge acts as an odometer for the engine. Engine hours should always be noted and documented so maintenance and lubricant changes may be performed at proper intervals.

CLOCK

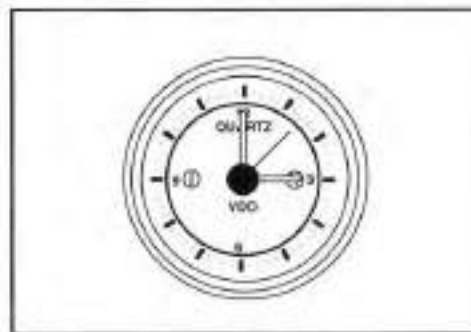

The analog quartz clock continuously indicates the correct time.

To adjust the time, depress the black center knob on the clock face and turn the dial clockwise until correct time is located.

NOTICE: If electrical disconnect switch is disengaged, clock will not operate.

LIGHTS BREAKER SWITCH

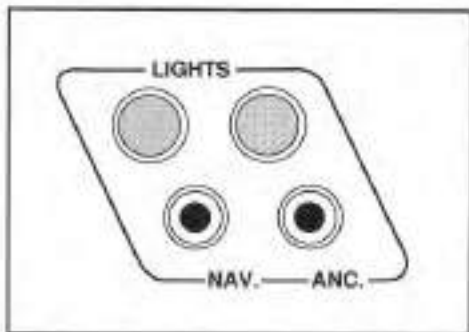

The navigation breaker switch "NAV" supplies power to:

- BOW COMBINATION SIDE LIGHT
The bow light is located at the very tip of the bow near the lifting ring.
- STERN LIGHT
The stern light is located at the center of the transom behind the rear lifting ring.
- FRONT POLE LIGHT
Refer to POLE LIGHT for location.

The anchor breaker switch "ANC" supplies power to:

- FRONT AND REAR POLE LIGHT
Refer to POLE LIGHT for location.

LIGHTS BREAKER SWITCH

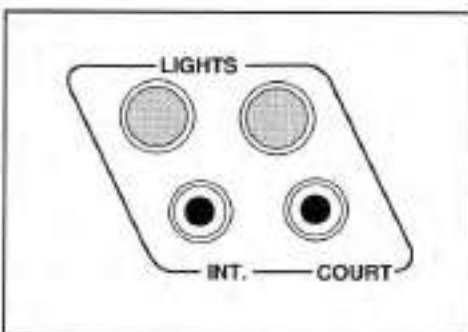

The interior breaker switch "INT" supplies power to:

- All lighting forward of the helm.

The courtesy breaker switch "COURT" supplies power to:

- All lighting to the rear of the helm.

OPTIONAL POWER BREAKER SWITCH

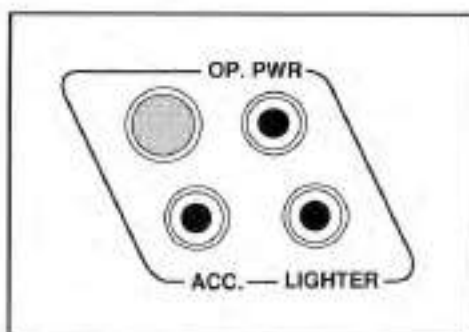

The optional power breaker "OP. PWR" supplies power to:

- Optional equipment that may be added such as digital depth finders, CB radios, etc.

The accessory breaker switch "ACC" supplies power to:

- Accessories added later.

The lighter breaker switch "LIGHTER" supplies power to:

- CIGARETTE LIGHTER

HORN BREAKER

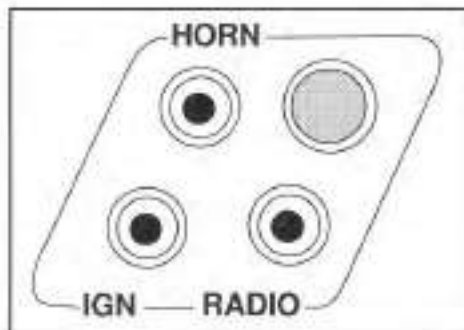

The horn breaker is located on the port dash panel and is activated by engaging the breaker and depressing the button.

HORN SIGNALS

1. **OVERTAKING-PASSING:** Boat being passed has the right-of-way. KEEP CLEAR.
2. **MEETING HEAD-ON:** Keep to the right.
3. **CROSSING:** Boat on right has the right-of-way. Slow down and permit him to pass.

CIGARETTE LIGHTER AND HORN BUTTON

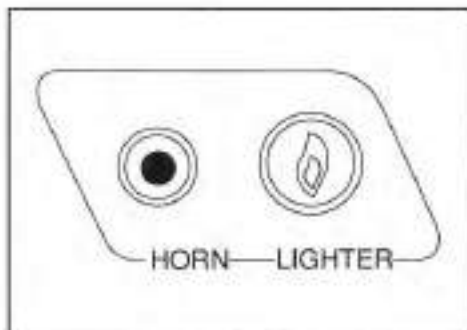

To operate cigarette lighter, press lighter in and wait until it pops out.

WHISTLE SIGNALS

ONE LONG BLAST:

Warning signal (Coming out of slip)

ONE SHORT BLAST:

Pass on my port side

TWO SHORT BLASTS:

Pass on my starboard side

THREE SHORT BLASTS:

Engines in reverse

FOUR OR MORE BLASTS:

Danger signal

FLAME PRECAUTIONS



! WARNING Sparks while fueling can cause an explosion! Extreme caution should be taken when an open flame is present on board. Gas fumes from the engine and fumes from the battery area are highly flammable and no flame or spark should come near these areas.

STEREO

UNIT CONTROLS AND OPERATION

1

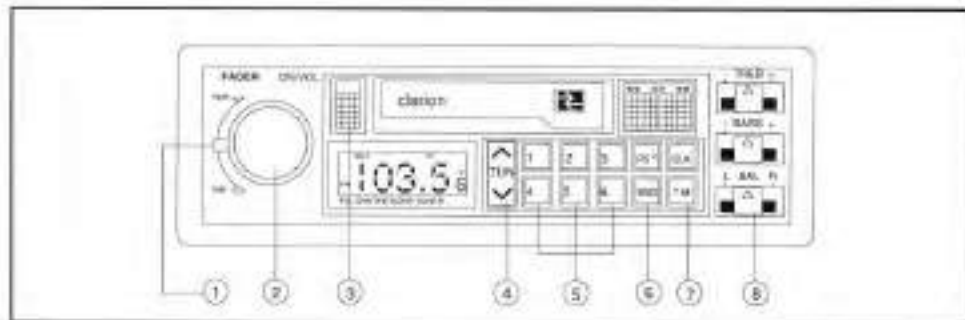

1. **FADER CONTROL KNOB**

Adjust volume between front and rear speakers.

2. **POWER SWITCH/VOLUME CONTROL**

Turn clockwise to switch unit on and increase the volume.

3. **EJECT BUTTON**

Depress the button to EJECT the cassette tape.

4. **UP/DOWN TUNING CONTROL BUTTON**

Press upper side to tune up the frequency and lower side to tune down the frequency.

5. **FM/AM TOUCHBUTTON MEMORY**

Up to 12 FM and 6 AM stations may be stored in memory for future recall.

6. **BAND SELECTOR BUTTON**

Press the button to select AM/FM1/FM2. When selecting an FM band, either FM1 or FM2 will appear in the display.

7. **TUNG MODE SWITCH**

Press this button to select MANUAL, SEEK or SCAN tuning.

8. **BALANCE CONTROL**

Slide the knob to right-hand to emphasize the right speaker and slide to left-hand to emphasize the left speaker.

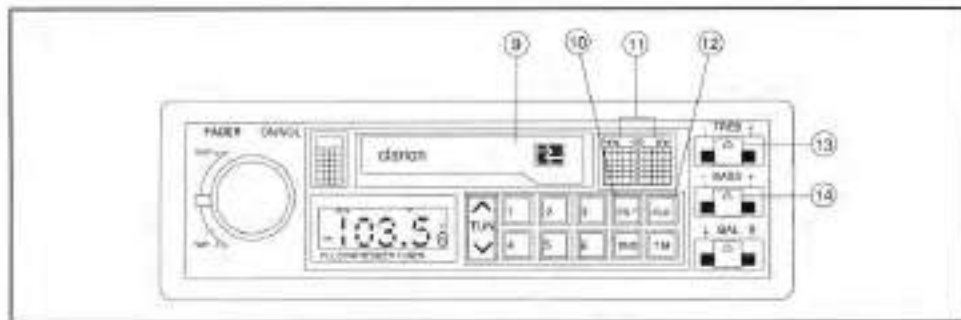

NOTICE: Please refer to radio owner's manual for detailed instructions.

9. CASSETTE TAPE DOOR

Insert cassette tape through this door to start playing TAPE.

10. PRESET SCAN/AUTO STORE PRE-SET SCAN

Press the button to activate the Preset Scan. This will instruct the tuner to scan each of the stations that you have stored in the touchbutton memory.

11. FF/REW BUTTONS AND PROGRAM SELECTOR

Depress the button whose arrow is in the SAME direction as the tape play arrow in the display to advance the tape at a high speed. Depress the button whose arrow is in the OPPOSITE direction as the tape play arrow in the display to rewind the tape at a high speed.

12. CLOCK SELECTION

For momentary Time or Frequency display, press the CLK button.

13. TREBLE TONE CONTROL KNOB

Slide the knob to right-hand to emphasize treble. To attenuate, slide to left-hand.

14. BASS TONE CONTROL KNOB

Slide the knob to right-hand to emphasize bass. To attenuate, slide to left-hand.

RADIO DIGITAL DISPLAY



1. TAPE PROGRAM INDICATOR

2. SEEK INDICATOR

3. STEREO INDICATOR

4. FM INDICATOR

5. FREQUENCY/CLOCK DIGITAL
DISPLAY

6. PRESET MEMORY CHANNEL
INDICATOR

SPEAKERS

1



Included as part of the stereo system are the stereo speakers. All installed speakers are compatible with the factory stereo system. The speakers are generally water resistant but spraying or soaking the speakers should be avoided.

- All speakers have a maximum wattage rating of 30 watts per channel, which is sufficient for the stereo system.
- Extreme volumes should be avoided to insure longer life of the speakers.

NOTICE: Please refer to radio owner's manual for detailed instructions.

OPERATIONAL INFORMATION

BREAK IN

DO NOT OPERATE AT SUSTAINED FULL THROTTLE DURING THE FIRST FIVE HOURS OF OPERATION.

DO NOT OPERATE AT HIGH RPMs IN NEUTRAL.

After the engine is thoroughly warmed up, and the boat is under way, open the throttle wide until full RPMs are reached.

DO NOT EXCEED MAXIMUM RPMs.

(RPMs should cease climbing after 10 to 20 seconds.) Reduce throttle to 2,800 to 3,000 RPMs, and cruise at or below that speed for 1/2 hour. Reduce speed to idle, open throttle wide, and operate at that speed for approximately 1 minute; reduce to cruise throttle for a few minutes and repeat. (Bringing the engine from idle speed to full throttle will load the engine and assist in seating the piston rings.) This cycle can be repeated from time to time during the first 5 hours of operation, but full throttle should not be sustained for more than 1 to 2 minutes.

FOLLOW THIS PROCEDURE ONLY WHEN CONDITIONS ARE SUCH THAT IT CAN BE DONE IN COMPLETE SAFETY.

DO NOT ATTEMPT TO BREAK IN AN ENGINE BY PROLONGED IDLING OR RUNNING IN AT THE DOCK.

During the early part of the break-in period, correct propeller selection can be confirmed. (With a normal load aboard, the engine RPMs should reach, but not exceed, maximum RPMs as listed under specifications for model.)

During the break-in, water temperature should be watched carefully, and speed reduced if overheating becomes evident. (For further information refer to engine manual.)

STARTING AND OPERATING

A routine pre-starting procedure should always be carried out before the first startup of the day.

1. Check oil in engine.
2. Inspect sight tube of fuel pump.
3. Check for gasoline fumes in bilges or engine compartment.
4. Operate engine room blower for four minutes to remove any fumes.
5. Operate bilge pump until bilges are dry.

Other items to be inspected may exist, depending on the nature of the boat. It is advisable to formulate a check list containing all items relative to the boat, and follow it faithfully. **REFER TO BOATMAN'S CHECK-LIST LOCATED NEAR THROTTLE CONTROL.**

Consult the local Coast Guard Auxiliary or Power Squadron for full details on boating safety.

NOTE: Bilge blowers, bilge pumps, and other accessories should not be connected to the ignition terminal or ignition circuit. The engine is equipped with an automatic choke which is opened by an electric heating unit. If the ignition is on for 1 or 2 minutes prior to starting, the choke will be open and inoperative, and starting may be extremely difficult.

IMPORTANT: DO NOT continue to operate starter for more than 30 seconds without pausing to allow starter motor to cool off for 2 minutes. This also will allow battery to recover between starting attempts.

(For further information refer to engine manual.)

BEFORE STARTING, BE SURE THE SHIFT SELECTOR IS IN NEUTRAL. Models equipped with Warner Velvet Drive transmissions, or Warner Vee Drives, have a factory installed safety switch incorporated, which prevents actuation of the starter unless the shift selector is in neutral. Other models do not. Before starting a cold engine, pump the throttle two or three times from closed to open to closed. Open throttle slightly above the idle position, and actuate starter. As soon as the engine starts, return the throttle toward closed to establish the engine speed at 1,200 to 1,600 RPMs, and give the engine a short period to warm up and smooth out. When all else is in readiness, reduce speed to idle, shift into gear, and proceed normally.

TRAILERING

2

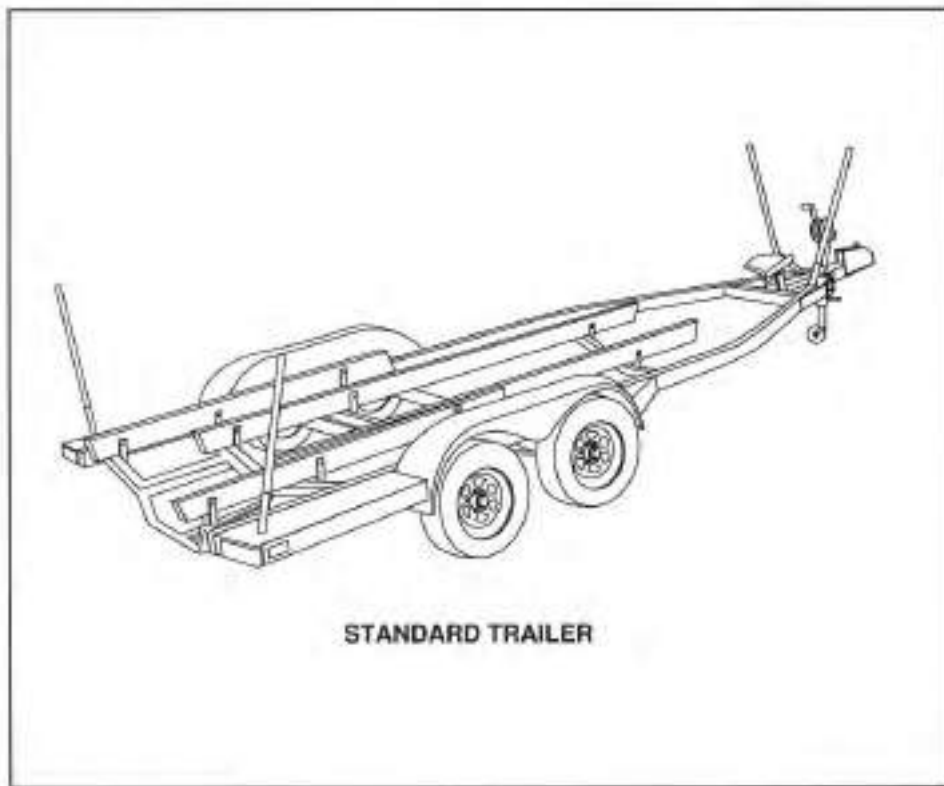

The trailer accompanying the purchase of a Supra is designed especially for Supra boats. It is important to remember the following guidelines to prolong the life of the boat and trailer.

1. Adjust weight of boat on the trailer so that it is correctly distributed on the trailer hitch.
2. It is recommended to secure boat to trailer with tie downs.
IMPORTANT: DO NOT use straps around any fender or light mounting locations.
3. Check trailer manual for correct tire pressure. Under-inflated tires may cause blowouts, trailer sway, or tire wear.
4. Refer to trailer manual for recommendations on maintenance, safety, and operational procedures.

NOTICE: Any questions may be answered by referring to the trailer manual or the manufacturer.

BACKING THE TRAILER

2

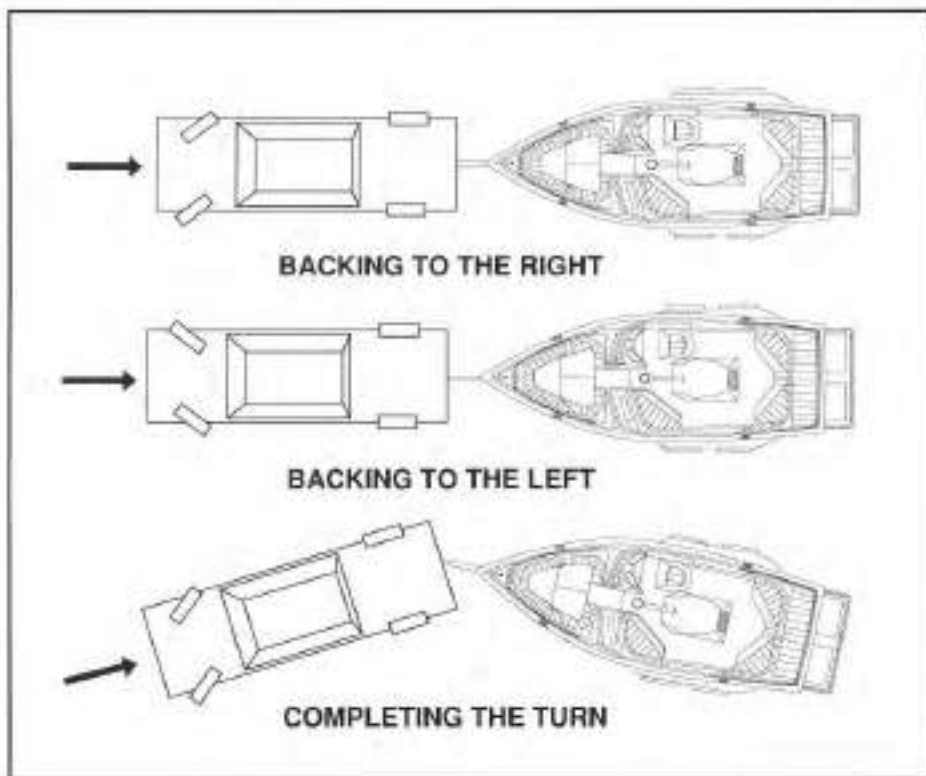

Backing the boat trailer may sometimes be a difficult task. It is recommended to practice backing the trailer in a vacant lot or open area before attempting it in a congested area.

Follow these basic rules when backing:

1. Turn the front car wheels in the opposite direction in which the trailer is to travel.
2. Back car normally once trailer turn is started.
3. DO NOT cut corners while driving on the highway.

UNLOADING PROCEDURE

2

To unload the Supra use the following guidelines:

1. Unplug all light cords before backing trailer into the water.
2. Continue to back trailer, with bow eye hook still in place, until the water is approximately one inch under the top of the fenders on the trailer.

NOTICE: Some ramps vary in degree of slope, so actual position may vary.

3. Follow the cold start procedure recommended in the motor manual.
4. After starting the engine, remove bow eye hook, center steering wheel and slowly place throttle in reverse. Ease back the throttle until the Supra starts to move.

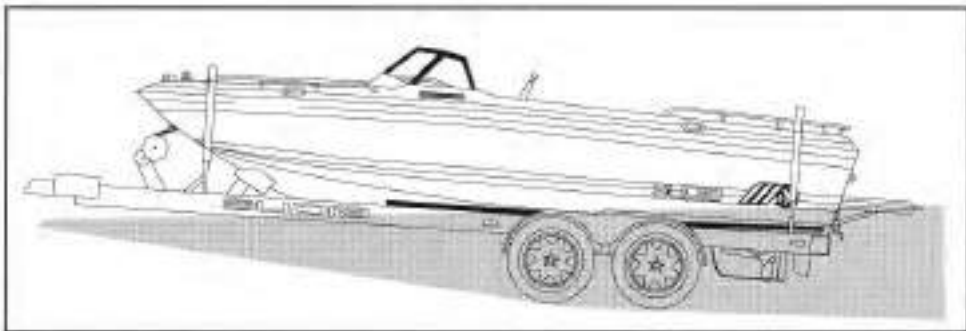

NOTICE: Do not rapidly move throttle in order to free boat from its dry carpet runners. If the trailer is not submerged to the correct depth, the nose of the boat will dip drastically once it has freed itself from the height of the runners, possibly damaging the bow.

LOADING PROCEDURE



To re trailer the Supra, follow guidelines in numbers one through four in the unloading guide. Please try to idle coast onto the trailer. **DO NOT power onto the trailer during rough conditions.**

On the trailer's tongue is a small guide rail that sites the course of the Supra as it moves onto the trailer. Once on the trailer, throttle up slowly within 1/2" of the guide rail, giving the correct forward alignment for proper clamp down. Once touching the guide rail nose, tighten up winch and slide boat into the saddle.

BOAT HOOKUP

2

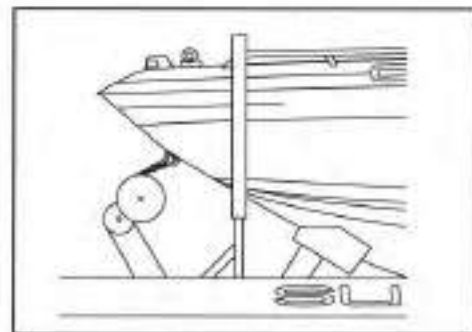

It is important that the boat is securely in place before moving trailer.

- Secure trailer hook to bow eye and tighten up winch firmly.
- Check winch lever for secure placement.
- Refer to trailer manual if needed.

TRAILER ALIGNMENT

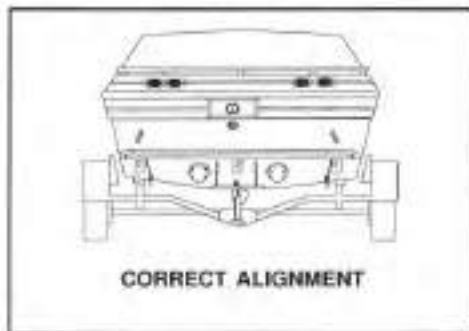

When pulling boat onto trailer, be sure the boat is centered as much as possible on the trailer.

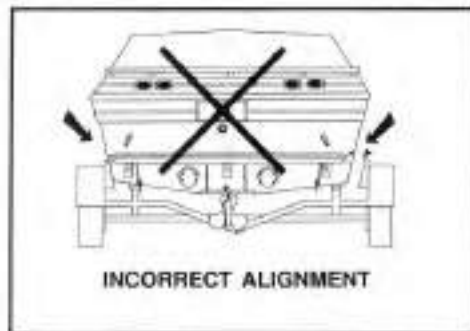

The distance between boat and runner board should be approximately equal on both sides.

HOISTING

2

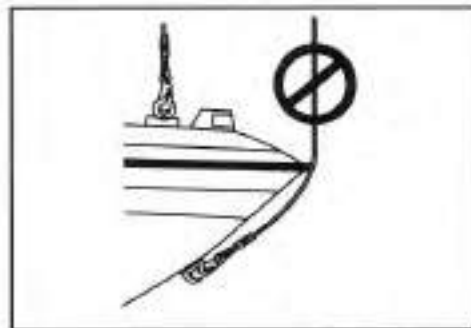
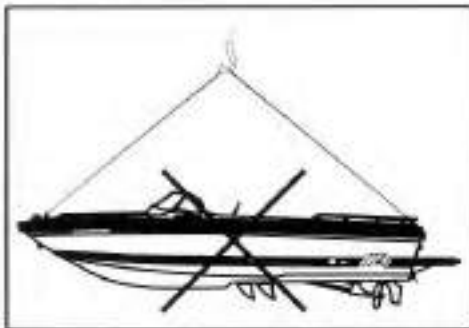
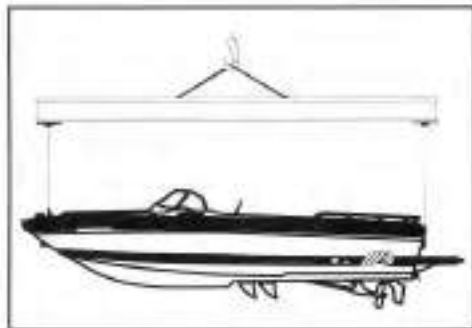

If there comes a time to remove the boat by some means other than the trailer, special attention should be given to the following recommendations.

- Hoist the boat using a horizontal lifting bar only (as shown in diagram).
- Operator should slowly and smoothly raise the Supra from the water without any harsh jerking so as not to damage the lifting eyes.

It is recommended to use a clevis pin and clevis for the lifting eyes since hooks tend to round the surface and damage plating on the lifting eyes.

- **DO NOT** use the ski bar to hoist the boat.

NOTICE: Improper hoisting may violate warranties and guarantees on the boat.

NOTICE: DO NOT use the bow eye to hoist the boat. Use the designated lifting rings on the deck to hoist the boat.

DRY STORAGE

2

When the boating and ski season comes to a close, it is recommended that the boat be removed from the water and stored for the winter months. It is extremely important that the correct winterizing procedures are read and followed to insure longer boat life.

1. Engine preparation

- Drain all water from engine cooling system by removing engine drain plugs (refer to engine manual).
- Reinstall all engine plugs and remove transmission intake hose. Inspect intake for any debris and remove if necessary.
- While engine is running, have another person slowly pour one gallon of anti-freeze into intake holes. Upon completion, and after antifreeze has circulated through engine, turn ignition off.
- Once again, remove all engine drain plugs and drain out antifreeze. Store drain plugs in a safe place.

NOTICE: This procedure will coat the inside of the engine's cooling system to prevent any damage due to freezing.

- Remove center and rear drain plugs and store in a safe place.
- Clean boat interior and exterior thoroughly. Inspect boat hull for any residue or algae growth and remove if present.
- Clean bilge area thoroughly and operate bilge pump to remove any water from the bilge lines.
- Remove all seat cushions and open all storage areas to air out boat interior. Replace cushions and close storage areas after interior is completely dry. This will prevent mildew from forming while boat is in storage.
- Top off fuel tank to prevent any condensation from accumulating in fuel system.
 - If water is present in fuel system, add a commercial dry gas product to fuel in the recommended amounts.

7. If boat is stored on a trailer, inspect boat's positioning so that it is resting correctly. If possible, raise the bow above the stern to allow any moisture to drain out.

8. Install canvas cover and secure straps properly (refer to canvas cover installation).

REMEMBER: During the winter months, water is a boat's worst enemy. Always store boat after interior is completely dry and periodically check the condition of the boat.

CANVAS COVER

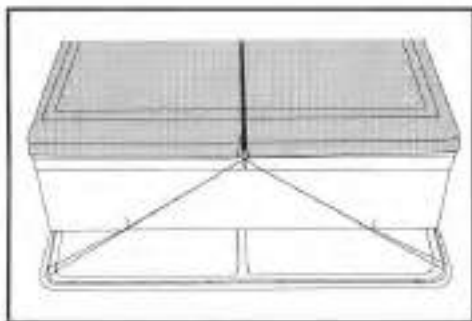

Supra uses only the finest quality canvas material and strapping to insure all Supras stay clean and dry in the off season.

All canvas covers have been specially designed to fit securely around each Supra boat. If the cover does not fit as tightly as expected, this is due to a percentage of shrinkage allowance after the cover is wet.

FOLDING COVER FOR STORAGE

2

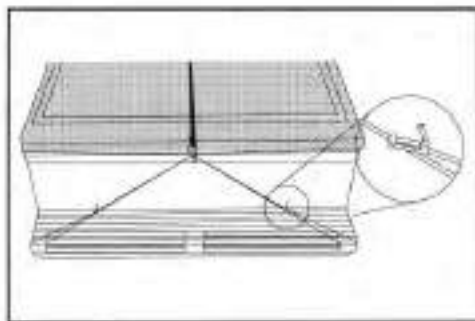

When folding cover for storage, remove excess water and store in a dry location. Do not allow cover to touch any concrete or rough surfaces which may scratch the canvas finish.

If any abuse or damage occurs, immediately patch or seal the area. Supra recommends using tent seam sealer for any seam damage and a fabric guard for any surface damage.

To cover the boat:

1. Be sure the cover fits snugly at the nose of the boat and then unfold from front to back.
2. Secure all fastening straps around trailer frame.
3. Pull rear pinch cord and tie off according to the diagram.

Canvas tears should be patched professionally and threads sealed to prevent leakage.

MAXIMUM CAPACITIES

SUNSPORT

MARAUDER

MARIAH

BRAVURA

SALTARE

PIRATA

MAXIMUM CAPACITIES

8 PERSONS OR **1100** LBS.

1400 POUNDS, PERSONS, GEAR

THIS BOAT COMPLIES WITH U.S. COAST GUARD SAFETY STANDARDS IN EFFECT ON THE DATE OF CERTIFICATION.
MANUFACTURER: SUPRA SPORTS

MODEL: 21' SERIES GREENBACK TM

DESIGN COMPLIANCE WITH NIMA REQUIREMENTS BELOW IS VERIFIED. MFG. RESPONSIBLE FOR PRODUCTION CONTROL.

LOAD CAPACITY * COMPARTMENT VENTILATION
STEERING, FUEL AND ELECTRICAL SYSTEMS
INTERNATIONAL LIGHTS * BASIC FLOTATION
MANEUVERABILITY

 NATIONAL MARINE MANUFACTURERS ASSN.

MAXIMUM CAPACITIES

8 PERSONS OR **1100** LBS.

1400 POUNDS, PERSONS, GEAR

THIS BOAT COMPLIES WITH U.S. COAST GUARD SAFETY STANDARDS IN EFFECT ON THE DATE OF CERTIFICATION.
MANUFACTURER: SUPRA SPORTS

MODEL: 21' SERIES GREENBACK TM

DESIGN COMPLIANCE WITH NIMA REQUIREMENTS BELOW IS VERIFIED. MFG. RESPONSIBLE FOR PRODUCTION CONTROL.

LOAD CAPACITY * COMPARTMENT VENTILATION
STEERING, FUEL AND ELECTRICAL SYSTEMS
INTERNATIONAL LIGHTS * BASIC FLOTATION

 NATIONAL MARINE MANUFACTURERS ASSN.

MAXIMUM CAPACITIES

10 PERSONS OR **1800** LBS.

2165 POUNDS, PERSONS, GEAR

THIS BOAT COMPLIES WITH U.S. COAST GUARD SAFETY STANDARDS IN EFFECT ON THE DATE OF CERTIFICATION.
MANUFACTURER: SUPRA SPORTS

MODEL: 21' SERIES GREENBACK TM

DESIGN COMPLIANCE WITH NIMA REQUIREMENTS BELOW IS VERIFIED. MFG. RESPONSIBLE FOR PRODUCTION CONTROL.

LOAD CAPACITY * COMPARTMENT VENTILATION
STEERING, FUEL AND ELECTRICAL SYSTEMS
INTERNATIONAL LIGHTS * BASIC FLOTATION

 NATIONAL MARINE MANUFACTURERS ASSN.

In compliance with Coast Guard regulations, Supra boats meet or exceed all safety standards designed for recreational boats.

To insure safe handling and performance, all Supra boats display a maximum capacity sticker. This sticker displays the maximum passenger and weight load allowable for that particular boat.

COAST GUARD REGULATIONS

The United States Coast Guard boating regulations prescribe minimum standards of safety, and it is necessary that your Supra remain in compliance with these regulations.

The following equipment should be on board your Supra at all times:

SAFETY PROCEDURES AND EQUIPMENT

2

- An approved hand-held fire extinguisher (provided by Supra).
- At least one Coast Guard approved PFD (personal flotation device) for each person aboard.
- At least one approved throwable device (ring buoy or buoyant cushion).
- One hand-, mouth-, or power-operated whistle or horn audible for at least one mile.
- Signal flares should be carried by boats going offshore.
- In addition, it is recommended that you carry an anchor, anchor line, tie-up liner, fenders, first aid kit, waterproof flash light, distress flares, and electrical tape.

SERVICE & MAINTENANCE



20'

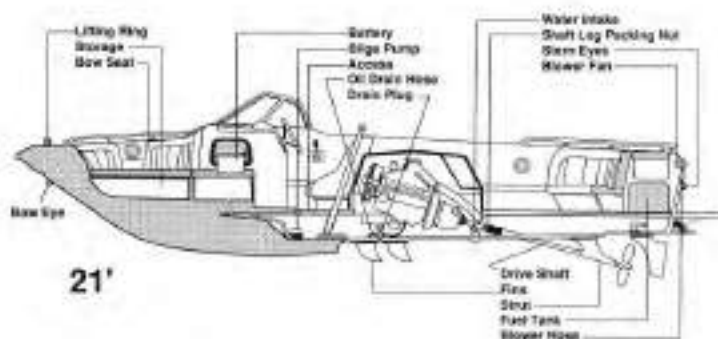

21'

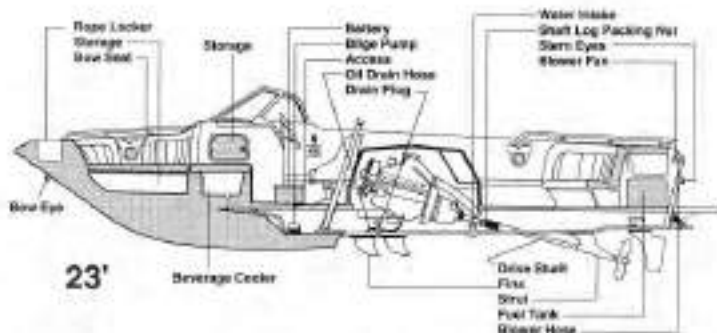

23'

The above illustration denotes the areas that may require cleaning, repair, or maintenance. It is important to have a basic understanding of mechanics and locations. However, it is recommended that any service beyond standard maintenance be performed by an authorized Supra dealer.

SERVICE AND MAINTENANCE ENGINE OIL AND FILTER

For your convenience, a maintenance schedule has been included in this manual. The items listed, outlining safety checks, lubrication, and general service, should be performed at regular intervals. Engine hours or time interval determines when service is necessary.

It is recommended that any replacement parts used for maintenance or for repair be supplied by an authorized Supra dealer.

NOTICE: You are responsible for keeping maintenance records on your Supra should you be required to prove that required maintenance was performed.

Crankcase oil should be selected to deliver the highest performance under weather and operating conditions present in operating area. In general, engine oils with low viscosity ratings are used when temperatures remain low or when better fuel economy is desired. Oils with high viscosity are used when temperatures remain high and when high performance is expected from the engine.

It is recommended that 10W-30 or 20W-40 or other high grade automotive oil with correct viscosity be used. All oils should have an A.P.I. classification of "SE," except for engine sizes of 460 and 454 or high temperature installations.

(Refer to lubrication chart.)

Maintenance Chart

Maintenance Intervals in Engine Hours

	Weekly	1st 25 Hrs.	50 Hrs.	100 Hrs.	Yearly
Change Engine Oil					
Replace Oil Filter					
Clean Oil Filler Cap					
Check Transmission Fluid Level					
Change Transmission Fluid					
Check Sea Water Strainer	*	*	*		
Clean Flame Arrestor					
Clean Crankcase Ventilating System					
Check Water Pump and Alternator Belts for Tension					
Change Fuel Filter					
Check Fuel System Lines and Connections for Leaks					
Clean Carburetor Fuel Inlet Filter					
Clean Transmission Oil Strainer Screen					
Lubricate Distributor Cam					
Inspect Breaker Points					
Check Condition of Spark Plugs					
Check Battery Electrolyte Level					
Check All Electrical Connections					
Check Cooling System Hoses and Connections for Leaks					
Tighten Engine Mount Fasteners					
Lubricate Throttle and Shift Linkage Pivot Points					
Check for Loose, Damaged, or Missing Parts					
Check Engine to Propeller Shaft Alignment					

* If engine overheats, visually check. If clogged, clean out.

The inspection and maintenance schedule is based on average operating conditions in utility service. Under severe operating conditions, intervals should be shortened.

OIL LEVEL CHECK

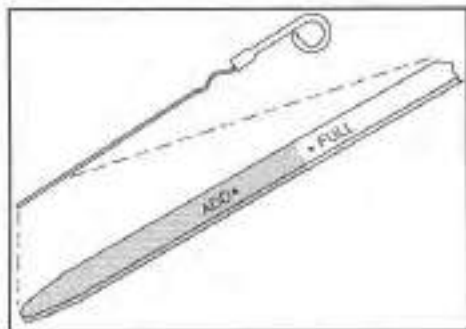

Engine oil level should be checked at regular intervals (such as every 5 engine hours). To obtain a true reading, when the engine is at operating temperature and turned off, check the oil on the level dipstick. Pull out the level dipstick, wipe it clean, and re-insert it all the way down or the reading will be incorrect. Pull out the dipstick again and note the position of the oil.

If the oil level is between the "FULL" and the "ADD" marks on the level dipstick, simply re-insert it. If the oil level is below the area marked "ADD," add oil up to the "FULL" mark immediately.

TRANSMISSION

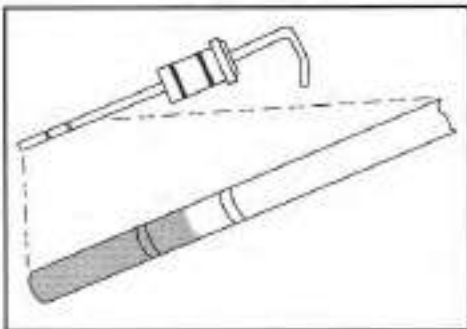

TRANSMISSION FLUID TYPE

Use only automatic transmission fluid type "A" in this transmission for 1:1 drive train with Warner gears. This fluid trade name is Dexron. **Please note with Power Plus transmission, the fluid should be 20W motor oil.**

MAINTAIN FLUID LEVEL AS FOLLOWS:

1. Boat must be at rest.
2. Engine should be at operating temperature but turned off while checking level.
3. Pull dipstick handle and remove dipstick.

4. Wipe fluid from dipstick and set in position in transmission fill hole.
5. Remove and note level indicated on dipstick. Add fluid if required to bring level up to the top mark.
6. Check the dipstick fluid level a second time to verify level.
7. Replace dipstick.

CHANGE FREQUENCY

Change transmission fluid once each year. (See Engine Owner's Guide.)

MAINTAINING TRANSMISSION FLUID LEVEL

Transmission fluid level should be checked frequently and fluid added if necessary. The level must be maintained between the two marks on the dipstick.

COOLING SYSTEMS

FRESH WATER COOLING SYSTEMS

This is an open circulating cooling system which is preferred for lakes and water reservoirs with low salt content; however, when engine is operated in salt water, the system should be flushed with fresh water periodically and before storage.

SALT WATER COOLING SYSTEMS

This is a closed cooling system with a solution of 50% antifreeze and 50% fresh water. This solution should be left in the system and replaced once a year as an annual maintenance item.

BODY LUBRICATION

Normal use of your Supra causes metal-to-metal movement at various points within the boat. If not properly lubricated, improper operation and wear may result. For body parts which require lubrication, a dripless oil may be used, although any lubricant should be used sparingly. Following application, excess lubricant should be carefully wiped away.

Driver seat track may be lubricated with a water resistant chassis lubricant.

SHAFT LOG PACKING NUT

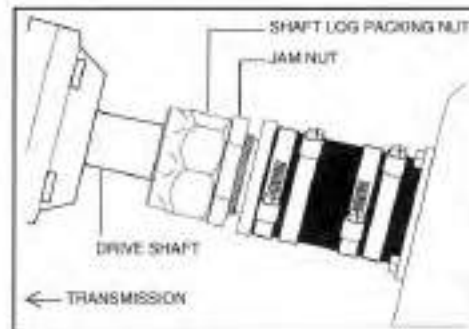
3

The Shaft Log Packing Nut should be checked periodically and adjusted if needed. To adjust:

1. Loosen the jam nut approximately 5 to 6 turns.
2. Tighten the large packing nut until hand tight. **DO NOT** overtighten.
3. Retighten the jam nut against the packing nut.
4. Check for leaks.

NOTICE: It is normal for the Packing Log Nut to drip at a rate of 15 to 30 seconds between drips.

STEERING ADJUSTMENT ACCESS

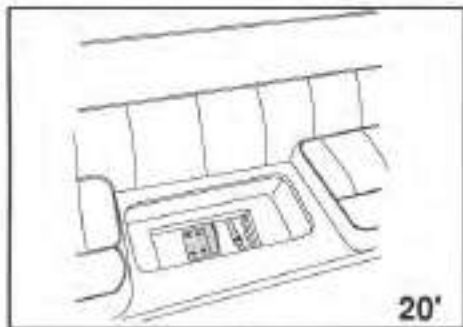

Access to the steering adjustment is located beneath the center cushion of the rear passenger seat.

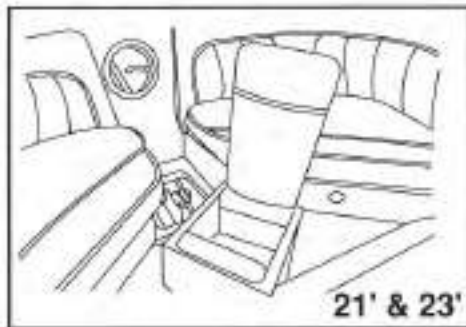

Access to the steering adjustment is located beneath the access step/tool box on the 21' Series and under the padded storage box on the 23' Series.

NOTICE: The complete steering system should be inspected by a Marine Dealer's Technician after the first 10 hours of operation and then on 200-hour intervals or three months, whichever comes first.

All steering connections should be installed and adjusted by a Marine Dealer's Technician.

BATTERY CABLE INSTALLATION AND PRECAUTIONS



1. Connect negative (-) battery cable to ground on engine.
2. Connect positive (+) battery cable to the starter solenoid.
3. Connect positive (+) battery cable to positive (+) post on battery and negative (-) battery cable to negative (-) post on battery.

! CAUTION Engine electrical system is negative ground. Failure to connect battery leads as outlined will damage the system.

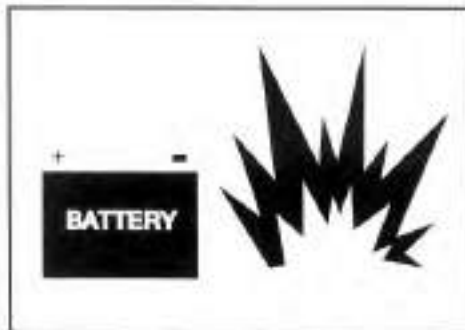

! WARNING Hydrogen and oxygen gases are produced during normal battery operation or charging. Sparks or flames can cause the mixture to ignite and explode if it comes near the vent openings.



! WARNING Sulfuric acid in the battery can cause serious burns. If spilled on skin or in eyes, flush with clear water immediately.

BILGE AREA DRAIN PLUG

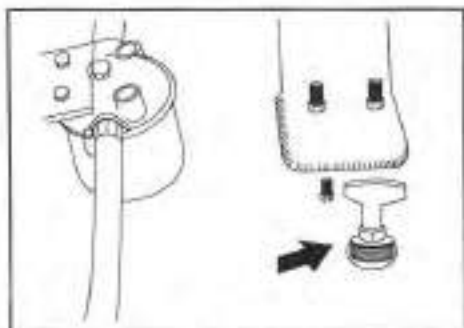

The bilge area drain plug is located at the extreme front of the motor well, directly in the center of the well under the engine. It is extremely important that the drain plug is always checked before starting the engine. The drain plug should be secured in place using a wrench.

! CAUTION DO NOT start engine until center drain plug is checked and secured in place. DO NOT try to install center drain plug while engine is running.

REAR DRAIN PLUG

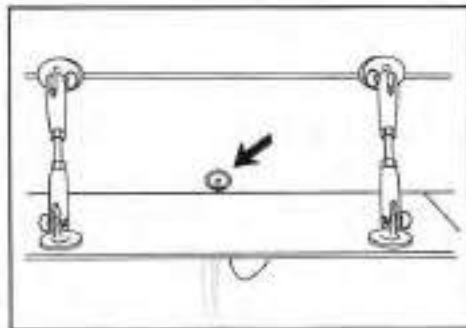

The rear drain plug is located in the center transom area of the boat just above the wake plate.

Before unloading the boat into the water, be sure the drain plug is securely in place. After loading the boat onto the trailer, remove the drain plug so that any water in the bilge area may drain out.

FUEL FILTER

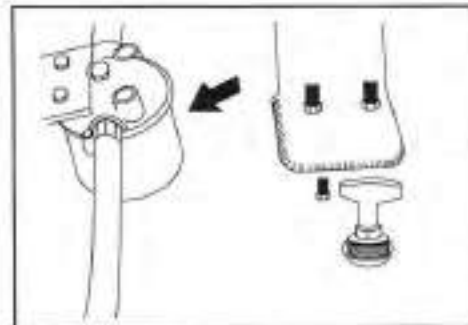

The fuel filter is mounted at the extreme front of the motor well.

The filter is easily changed by....

- Loosening two bolts located on top of the filter.
- Lowering filter housing and removing fuel filter.
- Replacing filter and gasket and retightening bolts.
- Refer to manufacturer's instructions for more details.

NOTE: DO NOT re-use filter or gasket.

FIBERGLASS CARE

Caring for a Supra boat is a general responsibility for all owners. Washing and waxing the boat hull and deck on a regular basis may extend the life and beauty of the Supra.

All Supra boats are constructed of a composite of differently structured fiberglasses combined with an outer layer of gelcoat. This gelcoat gives all Supras a shiny and smooth surface. It is good practice to rinse the Supra with fresh water after each day's ride.

It is recommended that the boat hull and deck be waxed after every 50 hours of use to decrease water friction and to lessen the potential for staining or spotting to the fiberglass surface.

In cases where the original gelcoat shine cannot be restored by waxing, the shine should return by hand buffing using any commercial polishing compound. Be sure to apply a new coat of wax containing Carnauba over the area that has been polished.

IMPORTANT: Porcelain cleaning powders are too harsh on the gelcoat surface and will permanently discolor the gelcoat if used.

Household detergents containing ammonia or chlorine should not be used.

Never use acetone or ketone solvents.

WASHING YOUR SUPRA

3

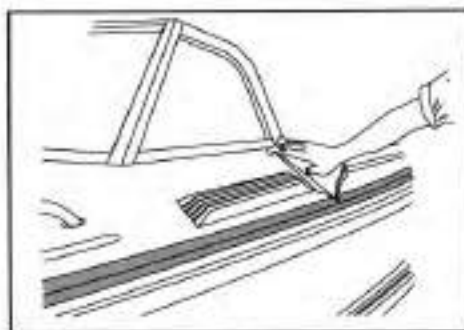

The easiest way to preserve the beauty of your Supra is to keep it clean by frequent washing. Wash the boat in lukewarm or cold water. Wipe the boat down immediately to avoid water spots.

Avoid using hot water or washing your boat in direct sunlight. Avoid strong soaps or chemical detergents. All cleaning agents should be rinsed from the surface promptly and not allowed to dry on the finish as they will cause spotting to occur.

WASHING AND WAXING RUB RAIL

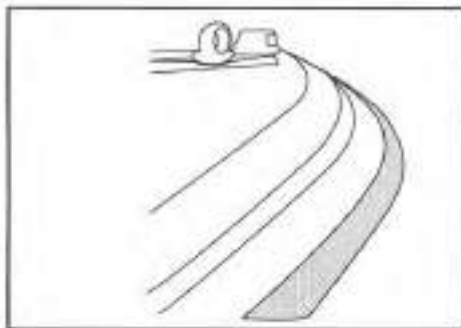

Use a sponge or other soft material to wash and wax the rubber rub rail. To wax, use a commercial automotive black bumper wax.

UPHOLSTERY CLEANING

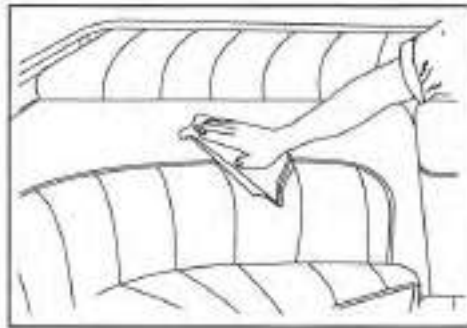

All upholstery items aboard the boat are made of a tough marine vinyl that is easily cleaned with a mild detergent or any automotive vinyl cleaner.

NOTICE: Take care not to repeatedly use harsh cleaners unless vinyl is abused or heavily soiled.

Strong detergents and cleaners will shorten the life of the vinyl.

WINDSHIELD CARE

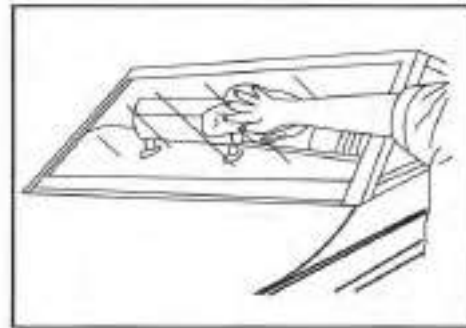

All Supra windshields are constructed of laminated safety glass to insure passenger safety.

The glass surfaces should be cleaned on a regular basis to insure that visibility is not obstructed.

Use a commercial glass cleaner to remove any spray spotting or stubborn stains that develop on the windshield.

Never use abrasive cleaners on glass surfaces as they may cause scratches.

FOREIGN MATERIAL DEPOSITS

Tree sap, bird droppings, chemicals in the air and water, and other foreign matter may damage the paint surface if not removed promptly.

Prompt washing may not completely remove all of these deposits. Additional cleaning may be required. Be certain chemical cleaners used for this purpose are safe for use on painted surfaces.

BOAT HULL PROTECTION

If your Supra is to remain in salt water for an extended period of time, the hull should be painted with a protective marine bottom paint.

This protection may also be used in fresh water areas where algae or grass is abundant.

TEAK WOOD CARE

If teak wood has been installed on a Supra boat, a small amount of maintenance care will be required to retain its natural beauty. Teak wood should never be varnished, but instead, teak oil or mineral oil should be used. Oil treatments should be applied at least four times per year.

If teak wood is in poor condition, use 220 grit wet and dry sandpaper to refinish the problem area. Reapply teak oil after sanding.

DRYING UPHOLSTERY

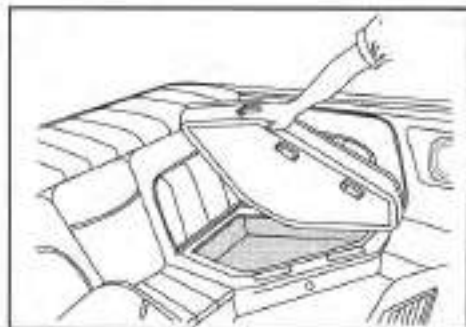

It is extremely important that all upholstery and storage compartments are thoroughly dried after each boating session. Open all storage compartments and slide all removable cushions out approximately 1" to allow air to circulate behind and underneath them.

TECHNICAL

IDENTIFICATION NUMBER

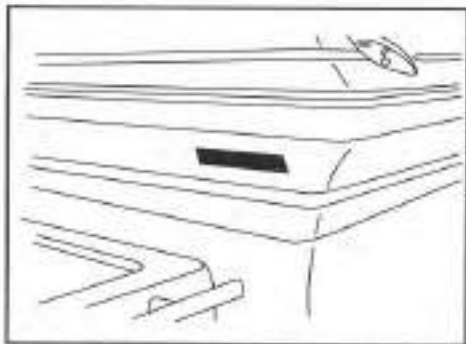

The hull identification number is located on the upper right hand side of the transom below the rub rail.

The following describes the identification number in detail.

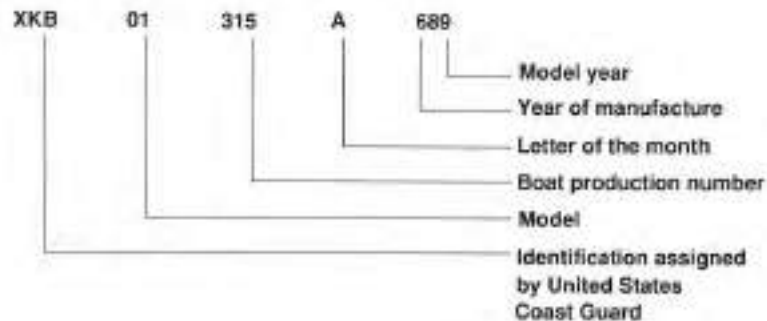

ENGINE DATA

ENGINE MODEL ITEM	351	350	454
HORSEPOWER @ 4400 RPM	240	260	330
MAXIMUM RPMs INTERMITTENT SERVICE CONTINUOUS SERVICE	4400 3600	4400 3600	4400 3600
IDLE SPEED IN GEAR (RPM)	600	600	600
SPARK PLUG GAP	0.035	0.035	0.035
SPARK PLUG TYPE	Autolite BTF3M Champion F 10.18 MM	AC#MR43T Champion #RBL8	AC#MR43T Champion #RBL8
OIL CAPACITY	4 qts. + filter	5 qts. + filter	5 qts. + filter
OIL FILTER	full flow replaceable cartridge		

LUBRICATION CHART

TEMPERATURE	API CLASSIFICATION AND VISCOSITY	OIL AND FILTER CHANGE INTERVAL
(0-32) ^o F (-18-0) ^o C	SAE 20 W "SE"	25 hours of operation or 30 days
(32-90) ^o F (0-32) ^o C	SAE 10 W 30 "SE"	50 hours of operation or 60 days
90 ^o F (32 ^o C) and above	SAE 10 W 40 "SE"	50 hours of operation or 60 days
ENGINE OIL CAPACITY 351 - 4 quarts + filter 350 - 5 quarts + filter 454 - 5 quarts + filter		

BATTERY SPECIFICATIONS

12 Volt marine type with tapered post connectors.

ENGINE SIZE	Cold Crank @ 0°F (-18°C)	AMPS for Load Test	25 AMP Rate (min) Reserve Capacity
350 & 351	350 Amps	170	80
454	465 Amps	230	125

WARNING: Hydrogen and oxygen gases are produced during normal battery operation or charging. Sparks or flames can cause this mixture to ignite and explode if it comes near the vent openings. Sulfuric acid in battery can cause serious burns, if spilled on skin or in eyes. Flush with clear water immediately.

ELECTRICAL WIRING DIAGRAM

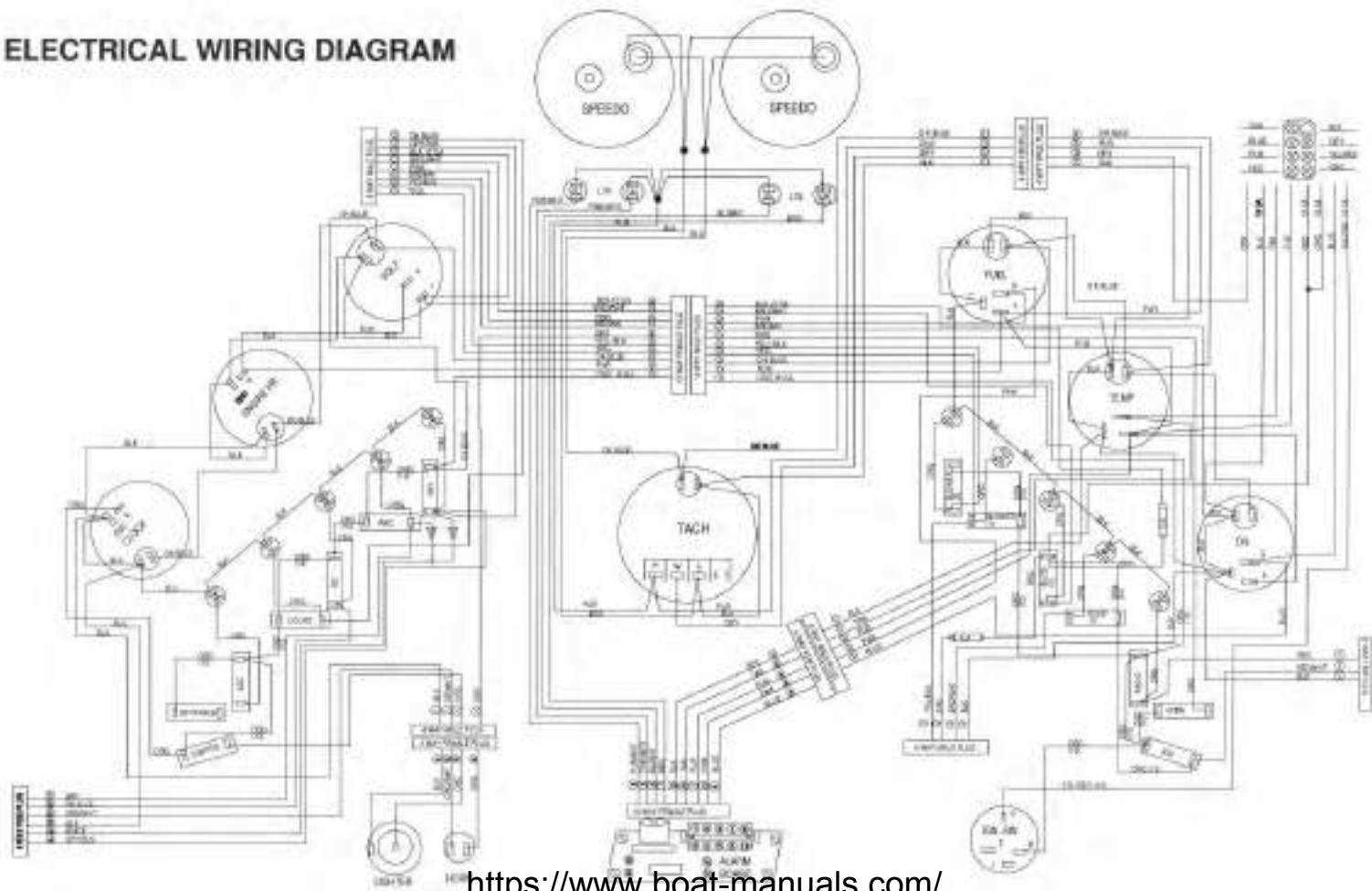

WARRANTY

LIMITED WARRANTY ON NEW SUPRA SPORTS BOATS

The new Supra Sports limited warranty is extended to the original purchaser of the boat during the warranty period.

LIABILITY DISCLAIMER

This warranty is expressly in lieu of all other expressed or implied warranties of Supra Sports, Inc., including any implied warranty of fitness for any particular purpose and in lieu of all other obligations or liabilities on the part of Supra Sports, Inc. Supra Sports, Inc. neither assumes nor authorizes any other person to assume for it any liability in connection with Supra Sports, Inc.

WHAT IS COVERED?

- A. Supra Sports, Inc. warrants to only the original purchaser each new boat hull and deck, registered and normally operated, to be free from structural defect or defects in workmanship.
- B. Except as otherwise indicated, this warranty covers your Supra for twelve (12) months from the date of delivery to the original purchaser.
- C. Any Supra dealer will make any repairs and adjustments to correct defects covered by this warranty.
- D. Warranty repairs (parts and labor) will be made at no charge subject to the authorization of factory personnel. Return transportation of any boat to the dealer or factory is the responsibility of the claimant.
- E. **To validate this warranty, a boat registration card must be returned to the factory within FIFTEEN DAYS of original purchase.**
- F. **For specific warranty information, please see the enclosed Supra Sports, Inc., 6 Year/600 Hour Limited Warranty.**

WHAT IS NOT COVERED?

- A. Damage, malfunctions, or failures resulting from misuse (e.g., racing, overloading), alteration, negligence, accidents, tampering, or improper adjustments or repairs.
- B. Engine, controls, batteries, or other equipment or accessories carrying their own individual warranties. (Appropriate adjustments to them are provided by their respective manufacturers.)
- C. The installation of machinery, equipment, and accessories not factory installed or equivalent in quality and design to parts supplied by Supra.
- D. Damage to gelcoat, such as crazing caused by impact, weathering, or from improper maintenance.
- E. Damage to any simulated woodgrain surface.
- F. Damage to upholstery, such as puncturing, storage in weather without protection, damage from harsh solvents.
- G. Any Supra boat which has been overpowered or overloaded (in excess of horsepower and/or capacity as specified on capacity plate on each Supra boat).
- H. Damage to any Supra resulting from submergence for any reason.

OWNER'S RESPONSIBILITIES

- A. Before operating the boat, it is necessary to read and fully understand this owner's manual and any other information delivered with the boat.
- B. It is the responsibility of all Supra owners to take their boats to an authorized Supra dealer to obtain warranty service.
- C. It is also the owner's responsibility to properly operate and maintain their Supra boat in accordance with this manual and other information delivered.
- D. Maintenance records must also be kept in order to show that required maintenance has been performed on the boat.

DEALER'S RESPONSIBILITIES

- A. To provide the customer with an adequate orientation in the general operation of a Supra boat. Also to review all systems and accessories included with a Supra.
- B. To deliver a complete owner's packet consisting of owner's manual, registration, and any warranties for separate warranted products aboard a Supra.

- C. To review all warranty information with customer and assist in filling out any warranty cards if necessary. To insure that any information or obligation from Supra or the dealership is clearly understood.
- D. To instruct the customer on how to obtain local service and out-of-area service for a Supra boat.

Additional Information

- SOME STATES DO NOT ALLOW LIMITATIONS ON HOW LONG AN IMPLIED WARRANTY WILL LAST OR THE EXCLUSION OR LIMITATION OF INCIDENTAL OR CONSEQUENTIAL DAMAGES, SO THE EXCLUSIONS AND LIMITATIONS MAY NOT APPLY TO YOU.
- THIS WARRANTY GIVES SPECIFIC LEGAL RIGHTS TO THE OWNER AND OTHER RIGHTS THAT MAY VARY FROM STATE TO STATE.
- NO ONE IS AUTHORIZED TO CREATE ANY OBLIGATION OR LIABILITY IN CONNECTION WITH SUPRA BOATS OTHER THAN THAT WHICH IS STATED IN THE WARRANTY STATEMENT.

PARTS UNDER WARRANTY

Along with Supra's warranty policy, many of the components which make up a Supra boat are also under individual warranty. These products all have specific warranty periods and conditions the owner should thoroughly understand. To help in obtaining any information or assistance, a list of product manufacturers has been compiled along with the items under warranty and their vendors. It is recommended that all warranty information be read and understood before contacting the vendor.

NOTICE: It is important to understand the conditions and terms of the warranty before contacting the vendor. Any questions about a specific part should be answered by contacting the vendor.

WARRANTY PARTS

ITEM	VENDOR	WARRANTY PERIOD	TELEPHONE NUMBER
Battery	Astro-Lite Battery Sumter Battery	2 years	(615) 523-3031
Engine	PCM	Refer to Engine Manual	(800) 848-0470
Prop	Michigan Wheel	*	(616) 452-6941
Stereo	LaVanture Products	1 year	(800) 348-7625
Bilge Pump	Altwood	1 year	(616) 897-9241
Horn	ITC Incorporated	1 year	(616) 772-9411
VDO Instruments	M & G Electronics	2 years	(804) 463-8070
Speedo's & Pick-ups	Air Guide Instruments	1 year	(800) 621-3058
Steering System	Teleflex	2 years	(215) 495-7011
Control Cables	Morse Controls	1 year	(216) 653-7701
Steering Wheel	Teleflex	2 years	(215) 495-7011
Trailer	SMP	1 year	(615) 337-3466

*Lifetime as long as the prop has not been misused.

CUSTOMER ASSISTANCE

The individuals associated with Supra Sports, Inc. are concerned with complete customer satisfaction. This concern includes the prompt resolution of any problems that may arise during the warranty period. Normally, problems encountered with Supra boats may be handled efficiently by a Supra dealer. However, if a problem arises and cannot be handled by a dealer or for which the solution is unsatisfactory to the owner, follow these steps until the problem is resolved.

STEP ONE

Identify the problem to a member of the dealership management staff. It is most likely that the problem will be resolved at this level.

STEP TWO

If the solution to the problem is unsatisfactory, have the problem documented by the dealer staff and then contact the area dealer representative.

The dealer representatives in your area are listed on the inside of the back cover of this manual.

STEP THREE

If, after contacting the area representative, the problem has still not been resolved, compile the documentation from Steps One and Two. Contact factory Customer Service at Supra Sports, Inc.

**Supra Sports, Inc.
P.O. Box 90
Greenback, TN 37742
(615) 856-6838**

Describe in detail, along with appropriate documentation, the original problem encountered and the reasons why service has been unsatisfactory to this point. If further action should take place to resolve the problem, Customer Service will dictate the appropriate action.

Since it is likely that the problem will be resolved at this level, it is extremely important that these steps be followed in sequence to insure that the problem is resolved promptly and efficiently.

STEP FOUR

Finally, if after following the three advised steps and obtaining all necessary authorization and documentation, the problem is still not resolved, the president of Supra Sports, Inc., will personally review the problem and dictate the appropriate action.

INDEX

A

Access Step/Tool Box..... 21

B

Battery

Battery box..... 11
Battery and cable installation..... 63
Battery specifications..... 72

Beverage cooler..... 16

Beverage holders..... 24

Bilge area inspection plate..... 22

Bilge pump switch..... 35

Blower switches..... 35

Bow eye..... 22

Bow light..... 19

Bow storage..... 16

Bow ski storage access..... 17

Bravura..... 2

Break in..... 45

Breaker switches

Accessory..... 39

Anchor..... 39

Navigation..... 39

Bulkhead Mirror..... 17

C

Cabin Storage Box..... 17

Canvas Cover..... 54

Folding cover for storage..... 54

Cigarette lighter..... 40

Cleats..... 26

Clock..... 38

Coast Guard Regulations..... 56

Cooling systems..... 61

Courtesy light..... 20

Customer assistance..... 79

D,E

Daily checklist..... 6

Dash panel

Port..... 32

Starboard..... 37

Dealer's responsibilities..... 77

Dome light..... 17

Doors, Entrance..... 13

Drain plugs

Bilge area drain plug..... 64

Rear drain plug..... 64

Driver storage area..... 15

Dry storage..... 53

Engine data..... 70

Engine hour gauge..... 38

Electrical wiring diagram..... 73

F

Fiberglass

Care..... 65

Detail..... 5

Fire extinguisher..... 24

Foot Step..... 18

Foreign material deposits..... 67

Fuel	
Filling the fuel tank.....	23
Filter.....	64
Gauge.....	34
Information.....	iv
Precautions.....	23
Tank.....	23
Vent.....	24

G,H,I

Gauges	
Engine hour gauge.....	38
Fuel.....	34
Oil pressure.....	33
Temperature.....	34
Voltmeter.....	38
Hoisting.....	52
Horn	
Signals.....	40
Switch.....	40
Hull	
Design.....	4
Protection.....	67
Identification number.....	69
Ignition.....	33
Instrumentation panel and controls.....	29

K,L

Keys	
Floating Key Chain.....	7
Ignition.....	7
Gas.....	7
Lanyard switch.....	35
Lifting rings.....	20
Lubrication	
Body.....	61
Chart.....	71

M,O

Maintenance chart.....	59
Marauder.....	1
Mariah.....	2
Maximum capacities.....	55
Mirror.....	8
Morse Lock Out.....	31
Motor box.....	12
Motor box storage.....	12
Oil	
Dipstick.....	33
Engine oil and filter.....	58
Level check.....	60
Pressure gauge.....	33
Owner's responsibilities.....	77

P,Q,R

Pirata.....	3
Pole light.....	19

Pole light receptacle.....	20
Propeller.....	28
Propeller Precaution.....	25
Quarter window vent.....	15
Rear passenger seat compartment.....	21
Rope locker.....	14
Rub rail.....	25

S

Safety procedures and equipment.....	56
Saltare.....	3
Seats	
Adjustment.....	8
Driver.....	8
Jump.....	21
Observer.....	9
Passenger.....	10
Service and Maintenance Drawings.....	57
Service and Maintenance.....	58
Shaft Log Packing Nut.....	61
Slalom course speeds.....	30
Ski locker.....	14
Ski platform.....	27
Detachable bracket.....	27
Ski pylon (bar).....	28
Ski storage, front.....	16
Speedometer.....	30
Speedometer pickups.....	26
Starting and operating.....	46
Steering adjustment access.....	62

Steering tilt adjustment.....	15
Stereo	
Controls and operation.....	41-43
Enclosure.....	18
Speakers.....	43
Stern light.....	19
Storage, front.....	13
Sun deck.....	14
SunSport.....	1

T,U,V

Tachometer.....	30
Teak wood care.....	67
Temperature gauge.....	34
Throttle lever.....	31
Trailerling.....	47
Backing.....	48
Boat hook up.....	50
Loading procedure.....	50
Trailer alignment.....	51
Unloading procedure.....	49
Transmission Fluid Check.....	60
Upholstery	
Cleaning.....	66
Drying.....	67
Ventilation Hatch.....	14
Voltmeter.....	38

W

Wake plate.....	25
Walk-thru windshield.....	11
Warning box.....	36
Warning lights.....	36
Warranty information.....	75
Liability disclaimer.....	75
Parts under warranty.....	78
What is covered.....	76
What is not covered.....	76
Washing.....	65
Washing and waxing rub rail.....	66
Wet Bar.....	18
Windshield care.....	66