



Gas Service Manual

17506 Marine Power Industrial Park
Ponchatoula, LA 70454
Parts Direct Line: (985) 386-3571 or (877) 388-9555
Parts Direct Fax: (985) 386-0076

TABLE OF CONTENTS

- SECTION 1. INTRODUCTION**
HOW TO USE THIS MANUAL
- SECTION 2. GENERAL INFORMATION**
BOATER'S BEWARE
PROPELLERS
FUEL SYSTEM
COMPASS
- SECTION 3. TUNE-UP PROCEDURES, SPECIFICATIONS AND TROUBLESHOOTING**
TUNING
IGNITION TIMING
FUEL SYSTEM SERVICE
TUNE-UP SPECIFICATIONS CHART
FIRING ORDER CHART
OIL DRAIN AND CHANGE
TROUBLESHOOTING GUIDELINES
- SECTION 4. ENGINE ELECTRICAL**
GENERAL INFORMATION
BATTERY
STARTER MOTOR
REPLACEMENT OF STARTER MOTOR
SHIMMING STARTER MOTOR (ENPAC ENGINES)
OILING STARTER PINION GEAR (SPORTPAC ENGINES)
IGNITION
DISTRIBUTOR REMOVAL
DISTRIBUTOR INSTALLATION
ALTERNATOR
DRIVE BELT REPLACEMENT AND ADJUSTMENT
WIRING DIAGRAMS
- SECTION 5. MSTs**
INTRODUCTION
ENGINE WIRING HARNESS, 350-502 CID
WIRING DIAGRAM, 350-502 CID
ECM DIAGRAM
SHIFT ASSIST WIRING DIAGRAM
MSTs TIMING JUMPER
IGNITION TIMING PROCEDURES (DELCO)
MSTs SYMPTOM DIAGNOSIS AND DIAGNOSTIC CHART
MSTs SYSTEM DIAGNOSIS
CONNECTOR IDENTIFICATION CHART
MSTs DIAGNOSTIC CHECK/CHART
MSTs SYSTEM RELAY CHECK/CHART
MSTs DIAGNOSTIC CHECK DIAGNOSTIC CHART
MSTs SYSTEM RELAY CHECK DIAGNOSTIC CHART
IGNITION SYSTEM CHECK/CHART

- SECTION 5. MSTs (CONTINUED)**
ELECTRONIC SPARK TIMING (EST) DIAGNOSTIC CHART (PART 1)
ELECTRONIC SPARK TIMING (EST) DIAGNOSTIC CHART (PART 2)
MANIFOLD ABSOLUTE PRESSURE (MAP) SENSOR DIAGNOSIS CHART
MANIFOLD ABSOLUTE PRESSURE (MAP) OUTPUT CHECK
- SECTION 6. EFI (ELECTRONIC FUEL INJECTION)**
- SECTION 7. FUEL**
CARBURETOR
FUEL PUMP
- SECTION 8. COOLING SYSTEMS**
INTRODUCTION
COOLING SYSTEMS DIAGRAMS
TROUBLESHOOTING COOLING SYSTEM
FRESH WATER COOLING SYSTEM DRAIN POINTS DIAGRAMS
DRAINING COOLING SYSTEM, RAW WATER COOLING
DRAINING COOLING SYSTEM, CLOSED COOLING
ZINC ANODE REPLACEMENT (FRESH WATER COOLING ONLY)
FILLING FRESH WATER COOLING SYSTEM
HEAT EXCHANGER PRESSURE CAP TEST
HEAT EXCHANGER PRESSURE CHECK
PRESURE CHECKING FRESH WATER COOLING SYSTEM
FLUSHING RAW WATER COOLING SYSTEM
- SECTION 9. MECHANICAL PROCEDURES**
GENERAL INFORMATION
CYLINDER BORES, PISTONS, RINGS AND CONNECTING RODS
CAMSHAFT BEARINGS
CYLINDER HEAD
MEASURING MAIN BEARING CLEARANCE
MEASURING CONNECTING ROD CLEARANCE
SPECIAL TOOLS
- SECTION 10. 181/250 CID (3.0L-4.1L)**
DESCRIPTION
ENGINE LUBRICATION
TOOLS AND SHOP EQUIPMENT
CLEANING
INTAKE-EXHAUST MANIFOLD REPLACEMENT
MANIFOLD RISER REPLACEMENT
THERMOSTAT HOUSING REMOVAL (FRESH WATER COOLED ENGINES)
THERMOSTAT HOUSING REMOVAL (RAW WATER COOLED ENGINES)
CIRCULATION PUMP REPLACEMENT
VALVE TRAIN COMPONENT REPLACEMENT
CYLINDER HEAD REPLACEMENT
TORSIONAL DAMPER REPLACEMENT
OIL PAN REPLACEMENT
OIL PUMP REPLACEMENT
TIMING GEAR COVER REPLACEMENT
PISTON AND CONNECTING ROD REPLACEMENT

SECTION 10. **181/250 CID (3.0L-4.1L) (CONTINUED)**
FLYWHEEL REPLACEMENT
CRANKSHAFT REPLACEMENT
CRANKSHAFT REAR OIL SEAL REPLACEMENT
ENGINE SPECIFICATIONS CHARTS
TORQUE SPECIFICATIONS FOR FASTENER TIGHTENING CHART
SPECIAL TOOLS

SECTION 11. **262 CID (4.3L)**

SECTION 12. **305/350 CID (5.0L-5.7L)**
INTRODUCTION
DESCRIPTION
ENGINE LUBRICATION
ENGINE LUBRICATION DIAGRAMS
ROCKER ARM COVER REPLACEMENT
ROCKER ARM AND PUSHROD REPLACEMENT
VALVE ADJUSTMENT
VALVE STEM SEAL AND VALVE SPRING REPLACEMENT
INTAKE MANIFOLD REPLACEMENT
HYDRAULIC LIFTER REPLACEMENT
ROCKER ARM STUD REPLACEMENT
EXHAUST MANIFOLD REPLACEMENT
EXHAUST MANIFOLD RISER REPLACEMENT
CYLINDER HEAD REPLACEMENT
TORSIONAL DAMPER AND FRONT CRANKSHAFT SEAL REPLACEMENT
FRONT COVER REPLACEMENT
OIL PAN REPLACEMENT
OIL PUMP REPLACEMENT
REAR CRANKSHAFT OIL SEAL REPLACEMENT
REAR CRANKSHAFT OIL SEAL RETAINER REPLACEMENT
MEASURING CAMSHAFT LOBE LIFT
CAMSHAFT REPLACEMENT
MAIN BEARING REPLACEMENT
CONNECTING ROD AND PISTON REPLACEMENT
OIL FILTER ADAPTER AND OIL FILTER BYPASS VALVE REPLACEMENT
CRANKSHAFT REPLACEMENT
FLYWHEEL REPLACEMENT
FLYWHEEL RING GEAR REPLACEMENT
ENGINE REPLACEMENT
ENGINE SPECIFICATIONS CHART
TORQUE SPECIFICATIONS FOR FASTENER TIGHTENING CHART
SPECIAL TOOLS

SECTION 13. **454/502 CID (7.4L-8.2L)**
INTRODUCTION
DESCRIPTION
ENGINE LUBRICATION
ENGINE LUBRICATION DIAGRAM
ROCKER ARM REPLACEMENT
ROCKER ARM AND PUSHROD REPLACEMENT
VALVE STEM SEAL AND VALVE SPRING REPLACEMENT

SECTION 13.

454/502 CID (7.4L-8.2L) (CONTINUED)

INTAKE MANIFOLD REPLACEMENT
HYDRAULIC LIFTER REPLACEMENT
EXHAUST MANIFOLD REPLACEMENT
EXHAUST MANIFOLD RISER REPLACEMENT
CYLINDER HEAD REPLACEMENT
TORSIONAL DAMPER AND CRANKSHAFT FRONT SEAL REPLACEMENT
FRONT COVER REPLACEMENT
OIL PAN REPLACEMENT
OIL PUMP REPLACEMENT
CRANKSHAFT REAR OIL SEAL REPLACEMENT
MEASURING CAMSHAFT LOBE LIFT
CAMSHAFT REPLACEMENT
CONNECTING ROD AND PISTON REPLACEMENT
MAIN BEARING REPLACEMENT
CRANKSHAFT REPLACEMENT
FLYWHEEL REPLACEMENT
FLYWHEEL RING GEAR REPLACEMENT
ENGINE REPLACEMENT
THREAD REPAIR
ENGINE SPECIFICATIONS CHART
TORQUE SPECIFICATIONS FOR FASTENER TIGHTENING CHART
SPECIAL TOOLS

INTRODUCTION

This comprehensive service manual was developed especially for *MARINE POWER ENGINES* (GM only) manufactured from 1986 to 1992. This manual was designed to provide information to dealers and professional mechanics.

It is important to know that, due to the nature of repair work, Marine Power, Inc. does not guarantee the end results of any procedure described in this manual. Each particular case and their results may vary. It is the desire of Marine Power, Inc. to provide a manual for the maintenance, care and general service/repair of *MARINE POWER ENGINES* by experienced mechanics/technicians. Marine Power, Inc. makes no further claims, representations or guarantees.

Marine Power, Inc. has developed this manual under the assumption that the maintenance and repair procedures are performed by technicians trained in servicing *MARINE POWER ENGINES* or other GM marine engine products. It is also our assumption that the technician is equipped with and/or has knowledge of common marine mechanic tools.

It is our recommendation that, before attempting any repair or maintenance procedures, the appropriate section is read thoroughly. This will assure knowledge of proper methods, tools and potential dangers.

Marine Power, Inc. assumes no responsibility for any loss/damage caused by failure to follow accurately and completely the instructions set forth in this manual with respect to any of its products. Marine Power, Inc. further assumes no liability or responsibility for any loss/damage caused by failure to follow the procedures outlined and/or observe the described precautions.

This manual contains all information, specifications and illustrations on product information that was available at the time of publication. Persons utilizing this manual should take care that the procedures being followed are applicable to the product being serviced. Dimensions, specifications and product content are subject to change without notice. Marine Power, Inc. assumes no responsibility with respect to changes and notifications, thereof.

It is imperative that, before servicing the product, these guidelines should be followed:

- Read the "Boater's Beware" section.
- If the engine's intake or exhaust openings are exposed during service, they should be covered to prevent accidental entrance of foreign material in the cylinders.
- Disconnect the battery cables. This will prevent electrical damage and/or shocks from occurring during servicing.
- Replacement nuts, bolts, studs and fasteners should be exact replacements. Mismatched or incorrect replacements can cause damage, malfunction or injury.

HOW TO USE THIS MANUAL

This service manual consists of thirteen (13) sections, each of which are listed in the main table of contents and is clearly marked by tabs. The sections are numbered 1-13 and each page within each section is numbered consecutively and is preceded by the section number (Ex: Page 32 of Section 10 is numbered: 10-32). The main table of contents at the front of the manual will direct you to the section (s) desired and will also give a breakdown of the main topics of each section. *NOTE: The EFI section is not complete at this time. This section is reserved for information regarding our Throttle Body Injection (TBI) and Port Fuel Injection (PFI) engines. When this section has been completed, it will be forwarded to you as long as a completed manual registration card (located in front of book) has been received by Marine Power.* Once the desired section is located, its' table of contents, located on the front page of that section, will list the individual topics. When the desired topic is located, all of the pertinent information is conveyed in a step-by-step basis. Some of the more complex processes will refer you to different sections of this manual for more detailed information or specifications. This was done to eliminate redundancy and to reduce the bulk of this manual.

This manual was written with the service mechanic and his/her environment in mind. It was written to be easily followed and understood and was printed on durable, reinforced paper. While we at Marine Power have great pride in our product and this manual, we realize that we are human and mistakes occur. If you should discover any abnormalities in this manual, please write, call or fax us with an explanation of where a problem is located in the manual along with a suggested correction (if any).

Our address is:

Marine Power, Inc.
Product Support Dept.
#1 Marine Power Industrial Park
Ponchatoula, Louisiana 70454

Phone #: 504-386-2081
Fax #: 504-386-4010

The tools referenced in this manual are available through Kent-Moore Tool Co. The following is their address and toll-free telephone number to contact them for any tool purchases necessary:

Kent-Moore Tools
28635 Mound Road
Warren, MI 48092
Phone #: 1-800-345-2233

DON'T FORGET TO COMPLETE THE SERVICE MANUAL REGISTRATION CARD (LOCATED IN THE FRONT OF THIS MANUAL) AND SEND TO MARINE POWER. THIS WILL ASSURE THAT YOU WILL RECEIVE UPDATES AND ADDITIONS.

GENERAL INFORMATION

SECTION 2

BOATER'S BEWARE.....	2
Engine Compartment.....	2
Engine Mounting.....	2
Engine Bed.....	2
Sea Water Piping.....	2
Exhaust Piping.....	3
Hydro-Lock.....	3
Detonation.....	4
Electrical Connections.....	4
PROPELLERS.....	4
Propeller Knowledge.....	4
Pitch and Diameter.....	4
Propeller Cupping.....	4
Propeller Rake.....	4
Optimizing Performance.....	5
Propeller Maintenance.....	5
FUEL SYSTEM.....	5
Fuel Tanks.....	5
Built-in Fuel Tanks.....	5
Mounted Fuel Tanks.....	6
Fuel Lines.....	6
Static Electricity and Fuel Tank Grounding.....	6
COMPASS.....	7-8

BOATER'S BEWARE

Before shipment, each engine has been carefully tested, inspected and drained of coolant. It may be necessary to delete or add oil from the engine and transmission for various engine installations. If the engine is equipped with fresh water cooling, it is imperative to fill the system with a 50/50 mix of ethylene glycol base antifreeze and clean fresh water.

ENGINE COMPARTMENT

The engine compartment should be well-planned giving consideration to accessibility and ventilation. Engines must have air as well as fuel to operate efficiently. The battery should be located as close as possible to the starter motor so that the battery leads can be kept short.

ENGINE MOUNTING

Engine installation is very important. If the angle is too severe (over 15 degrees), oil and fuel problems may be encountered.

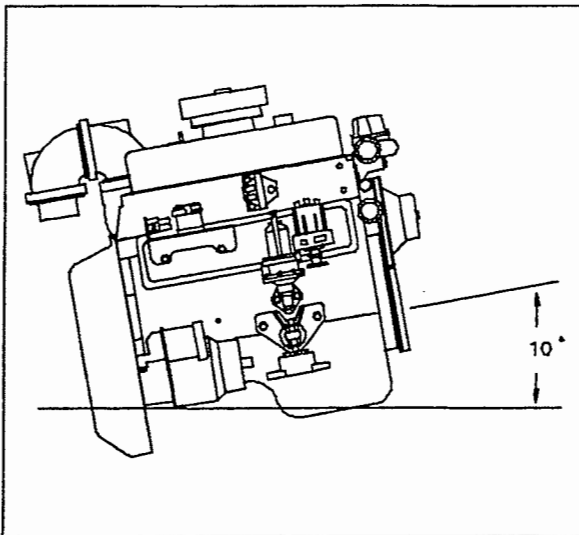
**ENGINE BED**

The engine bed should be of horizontal design and heavily constructed to maintain engine alignment.

All of the thrust used in moving the boat is transferred to the hull through the engine bed.

The standard engine has support mounts that are intended to be used on engine beds arranged for 22½" bolt centers. Use adequate bolts for each support. Make certain there is not interference on the underside of the engine between the oil pan or other components located in that area and the hull.

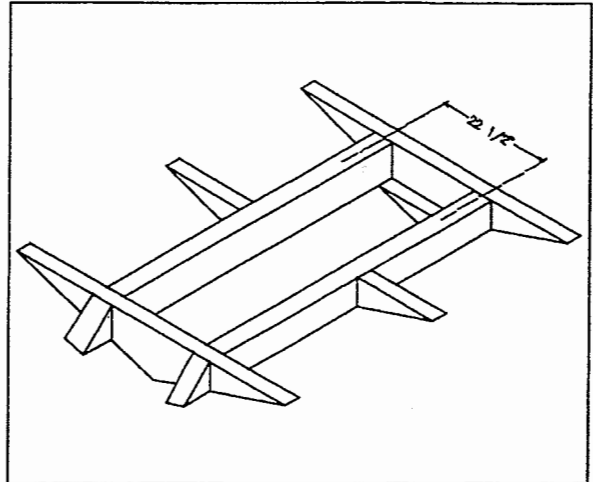
**SEA WATER PIPING**

CAUTION: DO NOT operate engine without water being supplied to raw water pump as impeller and engine will be damaged.

The through-hull fitting and sea cock should be placed as close to the engine as possible and be one size larger than the water pump inlet. The water pump inlet scoop should face the bow of the boat in an area where there are no obstructions that could cause water turbulence and prevent a solid stream of water from entering the sea scoop.

The hose on the suction side on the pump must be of a non-collapsing type. It is recommended that a sea strainer of adequate size be installed between the sea cock and the engine. If no sea strainer is installed, periodically check to clear debris from engine and transmission oil coolers.

SEA WATER PIPING (Continued)

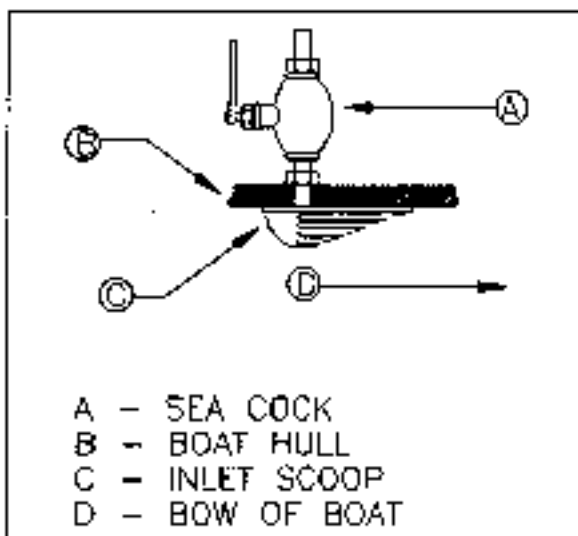

EXHAUST PIPING

WARNING: MARINE POWER does not warranty items damaged due to Hydro-Lock.

Exhaust lines must be installed to prevent water from returning to engine. Exhaust lines must have a definite slope to the transom of not less than $\frac{1}{8}$ " to foot of length. If pipe is used in the exhaust line installation, it must be separately supported so the weight of the pipe is not carried by the exhaust manifold outlets.

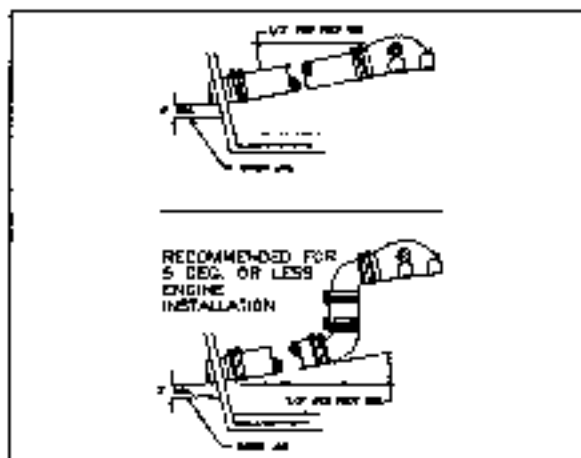

HYDRO-LOCK

Water can enter the engine cylinders through the exhaust system. Caution should be taken in an effort to avoid the following situations.

WARNING: Marine Power DOES NOT warranty items damaged due to Hydro-Lock or Detonation.

NOTE: It may be necessary to install 90° exhaust dumps adjacent to the manifold exhaust risers in some installations. Pay particular attention to installations with exceptionally long sloping exhaust routing, i.e., tunnel drive or negative engine installation angles, such as V-Drives. Consult your dealer.

1. **FOLLOWING WAKES:** Sudden slow-downs cause the boat wake to flow over the transom of your boat.
2. **ENGINE SHUTDOWN:** Sudden engine shutdown while the boat is moving may force water into the exhaust system.
3. **IMPROPER INSTALLATION:** Refer to Exhaust Piping section. An exhaust system without flappers and the specified incline increases the likelihood of water entering the engine.
4. **IMPROPER HOISTING:** Operators are sometimes tempted to reduce hoisting time for propeller changes by hoisting only the boat stem. Such hoisting can cause residual water in the exhaust system to enter engine cylinders.

Water entering engine cylinders will cause the engine to hydro-lock. To remedy this situation, take the following steps:

1. Remove all spark plugs.
2. Remove coil wire.

DANGER! DO NOT stand near engine while cranking. Water may be forced out of cylinders at high pressure causing injury.

3. Crank engine for 15 seconds.
4. Replace spark plugs and reattach coil wire.

HYDRO-LOCK (Continued)

5. Start engine - if there are any abnormal sounds - STOP ENGINE immediately! Contact your MARINE POWER dealer.

DETONATION

This condition, sometimes referred to as "pre-ignition" or "pinging", is very damaging to a marine engine. Almost everyone has experienced "pinging" while driving an automobile up a hill. This same "pinging" may be more difficult to hear in a marine engine. If a marine engine begins to "ping" and the engine RPM is not reduced, the engine will fail in a short period of time. *Detonation failures are not covered by warranty* and can be detected by piston erosion, ring gland fracture, cupped intake valves, etc. Such detonation can be caused by:

1. High engine temperature.
2. Incorrect ignition distributor timing.
3. Engine overloading.
4. Poor fuel quality.
5. Fuel starvation.

Be certain your servicing dealer checks for detonation during sea trial. Also, be aware that "pinging" - sometimes a "ringing" - in marine applications, can occur anytime.

ELECTRICAL CONNECTIONS

All electrical connections should conform to U.S. Coast Guard or Yacht Safety Bureau standards.

PROPELLERS**PROPELLER KNOWLEDGE**

The selection of a properly sized and pitched propeller is as important as the selection of your engine. The propeller is significant in handling characteristics, fuel economy, speed, acceleration, engine performance and safety. When the proper propellers are selected, the boat owner will enjoy his craft with maximum pleasure. Improper propeller selection can make the

owner's life miserable with poor engine performance and boat handling. Complaints to this nature would surely follow. This situation may be avoided by understanding and applying propeller technology.

PITCH AND DIAMETER

Propellers are described by two numbers. The first number is the pitch of the blades and the second number is the diameter.

Theoretically, pitch is the distance a propeller would move forward during one 360° rotation. It is important to realize that, although the pitch may be 16 inches, in water the pitch may be reduced by slippage, thus reducing the pitch to approximately 14 inches. The function of pitch is to provide distance.

The diameter is measured from the center of the propeller to the tip of the blades, then multiplying by two. The larger the diameter, the greater thrust may be used to move the boat. The function of diameter is to provide thrust.

PROPELLER CUPPING

Propeller cupping is a procedure that curls the trailing edges of the blades away from the boat. This blade modification allows the propeller to "grab" the water better and propel the boat forward.

In some applications, a cupped propeller will improve fuel efficiency to as much as 20 percent. Speed may also show improvement with propeller cupping. Cupping allows the propeller to work better with low and high pressure. A cupped propeller will hold high pressure water during ventilation or cavitation. Another fact worth noting is that a cupped propeller that remains fully submerged is less efficient. It should also be noted that cupped propellers are most efficient on stern drive applications and somewhat less advantageous in inboard application due to the fact that inboard props generally do not turn fast enough.

PROPELLER RAKE

"Rake" is a term that describes the degree of measurement of the slant of the blade. A blade's slant

PROPELLER RAKE (Continued)

starts at the hub and draws back to the apex from its tip. A standard rake varies from 20° to -5°. Ventilation or cavitation will be less likely with a higher angle of rake.

OPTIMIZING PERFORMANCE

A correct propeller will provide optimal performance from the engine/stern drive or engine/transmission combination. It is possible for two identical boats to perform differently with identical props. Although boats may appear to be identical, often they are run and loaded differently causing the difference in performance.

Typical wide open throttle would range between 4300-4600 rpm's. The pitch of the propeller allows for performance to be in this range.

PROPELLER MAINTENANCE

It is important to properly maintain the propellers and inspect them on a regular basis. Here are a few suggestions for maintaining your propeller:

1. Before installing a propeller, make sure the shaft and propeller bushing has been coated with marine grade grease. This will eliminate corrosion that may permanently weld the propeller to the shaft.
2. Examine the propeller blades for smoothness. If rough or jagged edges are found, have them milled smooth. This will decrease the friction of the blade against the water.
3. Examine all blades to make sure they are in the same plane and not bent backwards or forwards.
4. Carefully examine the hub for cracks.
5. If the propeller is missing a significant amount of metal, have it checked by a qualified marine mechanic or propeller specialist. They will examine the propeller for balance to assure that it doesn't run out of true which could break up gears and shafts in the drive system.
6. Inspect props for monofilament fishing line or other obstructions that may be wrapped around the shaft. If any is found, make sure that it is removed carefully and that it has not cut the prop shaft seal and damaged it.

FUEL SYSTEM

FUEL TANKS

Many areas, especially coastline areas, are subject to humidity and immediate temperature changes. It is important that your fuel tank is kept full to prevent condensation from forming and entering the fuel system during these temperature changes. When the tank is kept full, it keeps the air space at a minimum thus preventing harmful moisture droplets from forming.

Fuel should not be left in the fuel tanks for extended periods of time. Fuels today contain ingredients that will change into gummy substances when stored for any length of time. These substances will cause carburetor problems along with poor spark plug performance. A gasoline additive may be used to help keep the carburetor and spark plugs running at their best.

BUILT-IN FUEL TANKS

Caution and common sense should be used when selecting and installing all parts of the fuel system in order to provide maximum service and protection against leakage.

Cutting corners and costs may not be in your best interest when installing fuel tanks. Consideration to movement and motions should be applied when installing the fuel lines. Therefore, a flexible, reinforced line should be used. The copper fuel tubing should be carefully flared and installed. During the flaring process, the tube should be annealed (heated, then slowly cooled) to protect the tubing from becoming brittle or hardening.

CAUTION: Compression type fittings should NOT be used because they are easily overtightened, which places them under a strain and subjects them to fatigue. Such conditions will cause the fitting to leak after it is connected the second time.

BUILT-IN FUEL TANKS (Continued)

The fuel filter capacity must be large enough to handle the fuel flow requirements of that particular engine as set forth by the engine manufacturer. Anti-siphon protection is required and a manually-operated valve may be installed in applications where anti-siphon protection is not provided. This valve should be easily accessible and located between the engine and the tank.

MOUNTED FUEL TANKS

An ideal fuel tank installation would be in a dry, well-ventilated location. The tank should be located in an area where leakage may be readily detected, such as in front of the cockpit. However, depending on your type of boat, this may not be feasible. Therefore, caution should be used when installing the fuel tank.

Maximum air circulation is a major consideration in the placement of the fuel tank. It is important that the tank does not come in contact with the boat hull. The tank supports and/or hold-downs should be fastened to it firmly and should be insulated from the actual tank surface. The insulation material should be non-absorbent and non-abrasive. If the fuel tank is mounted in the forward portion of the boat, make sure that the tank is securely fastened and protected as shock loads in this area may be as high as 25 g's.

FUEL LINE

IMPORTANT: In repower applications, inspect all fuel lines for possible restrictions.

NOTE: Fuel tanks should be installed below the height of the carburetor. It is recommended that an anti-siphon valve be included in the fuel line.

A 3/8" (inner-dimension) minimum tubing is recommended for the 181, 250, 262, 305, 350 (all models) and standard 454 CID fuel line from the tank to the engine. A 1/2" (inner-dimension) minimum tubing is recommended for the premium and performance

454, 502 and 540. It should be adequately secured and provided with a flexible section near the engine to reduce vibration to the line. Fittings for the tubing should conform to Coast Guard or Yacht Safety Bureau standards. The use of a large capacity water trap and fuel filter on this line is recommended. Fuel tanks should be a size adequate with the hull requirements and should be anchored securely and vented in such a manner to conform to Coast Guard regulations.

The fuel tank filling arrangements should conform to all safety regulations, and must be outboard. The installation of an approved fuel shut off valve at the tank is mandatory.

STATIC ELECTRICITY AND FUEL TANK GROUNDING

Static electricity is generated when two dissimilar materials move over each other. Gasoline flowing through a pipe or fumes being released through the air will certainly cause potentially dangerous static electricity. It is during dry weather conditions that static electricity is the most prevalent. It is important to realize that these conditions require additional caution when filling the tank on your boat.

CAUTION: Atmospheric conditions may increase the chances of static electricity occurring. Certain types of clothing, such as synthetic types, will increase the chances of producing harmful static electricity.

When taking on fuel, static electricity can be dangerous. It is necessary to provide a direct metal to metal contact between the fuel hose nozzle and the water in which the boat is floating. A good ground will be made if the fill pipe (on the boat) and the fuel nozzle are both made of metal and makes contact with the fuel pipe deck plate.

Some boats are manufactured using plastic or rubber filler pipes. This type of fill line does not give an adequate ground. If replacing the plastic or rubber filler pipe with a metal one is not feasible, it is possible to connect the deck fitting to the tank with a copper wire (minimum 8 gauge).

STATIC ELECTRICITY AND FUEL TANK GROUNDING (Continued)

Proper grounding is essential and the fuel line from the tank to the engine should be continuous metal to metal. If any part of the fuel line is not continuous metal to metal, a copper wire must be installed to bridge the non-metal material. It is important to realize that the grounding is complete when there is continuous metal from the deck plate to the engine to the hull to the water.

In cases where fiberglass fuel tanks are used, it is important that these tanks are properly grounded. A copper wire should be imbedded (preferably by the boat manufacturer) in the fiberglass and connected to the fuel filler neck and the sea water inlet fittings.

CAUTION: DO NOT use a fiberglass fuel tank unless a grounding wire has been properly installed.

It is recommended that insulated rubber soled shoes be worn to prevent static electricity or static "shocks". Before filling your fuel tank, every effort should be made to ground yourself. When the fuel tank cap is opened, it releases fumes into the air. At this point, any static shocks produced may cause an unexpected explosion. There are two simple ways to ground yourself: (1) Touch the engine block or other metal object that is attached by metal to the water; (2) Dip your hand in the water your boat is floating in.

COMPASS

A properly mounted, accurate compass is one of your boats' most important pieces of equipment. This particular piece of equipment will prove to be invaluable should weather conditions change and visibility is limited. There are several points to consider when selecting and installing a compass.

- Select an accurate, quality compass: *It is important to select a compass that is relative to your needs. Before buying, hold the compass in your hand, simulate the tilting, pitching and turning*

motions of your boat. Look at the compass ball, it should have a stable and smooth gliding motion. The compass ball should come to rest without hesitation.

- Location: *The proper location is crucial and should provide accuracy and comfort. The compass should be comfortably seen by the boat operator whether sitting or standing behind the wheel. Poor visibility conditions (in daylight and darkness) should be considered when deciding on a compass location. The view of the compass should not be obstructed by the steering wheel, shift or throttle levers.*

The compass should be not be located within two feet of any magnetic instruments, detectors, indicators or metal objects that may distort the compass readings. Keep in mind that these objects may not be easily seen.

- Pre-installation: After the location has been decided upon, move the compass around in the location area. Watch for any deviation of the compass readings. Install (temporarily) the compass in its location. Perform the following procedures to verify that the compass is reading true. If the compass ball moves during any of these procedures, consider another location for the compass.

1. *Turn all lights, switches, radios and instruments on and off.*
2. *Start your engine. (Make sure water is circulating through the engine)*
3. *Turn on your windshield wipers and sound the whistle or horn.*
4. *Move your throttle and shift levers.*
5. *Turn on auxiliary generator (if equipped).*

- Installation: *Now it is time to install your compass. Be sure the surface is solid so that pivotal wear vibration is limited. It is important that the line through the lubber line and the compass ball pivot is exactly parallel to the keel of the boat. Establish a "fore and aft" line of the boat by using a stout string or cord using care when transferring the line to the compass set. (Also, realize that, if the compass is not properly aligned, it will cause you to be off course. This may later expose you to a dangerous situation should you wind up off course, especially*

COMPASS (Continued)

during periods of limited visibility.)

Be careful when placing objects near the compass after installation. These objects may appear to be harmless, but in fact, may cause the compass to give false readings. Also, be aware when installing optional equipment on your boat after the compass has been installed. This newly installed equipment may effect your compass readings.

TUNE-UP PROCEDURES, SPECIFICATIONS AND TROUBLESHOOTING

SECTION 3

TUNING.....	2
Introduction.....	2
Performance Tuning.....	2
Battery Check.....	2
Mechanical Adjustments.....	2
Manifold Bolts.....	3
Compression Check.....	3
Spark Plugs.....	3
Spark Plug Maintenance.....	3
Spark Plug Wires.....	4
Spark Plug Analysis.....	4
IGNITION TIMING.....	6
Using Initial Timing Connector (Deico System).....	6
FUEL SYSTEM SERVICE.....	7
General Information.....	7
Carburetor.....	7
Vacuum Gauges.....	8
TUNE-UP SPECIFICATIONS CHART.....	8
FIRING ORDER CHART.....	9
OIL DRAIN AND CHANGE.....	9
TROUBLESHOOTING GUIDELINES.....	10

TUNING

INTRODUCTION

A properly tuned engine is essential to the performance of your engine. However, an engine with poor compression due to worn piston rings, blown head gasket or burned valves will not perform efficiently after a tune-up. A compression check on all cylinders should be performed to assure satisfactory results of a tune-up.

A tune-up will directly enhance the performance of your engine with improved fuel economy and efficiency. It is important that the engine is tuned to the engine manufacturer's specifications. (Refer to Tune-up Specifications, page 3-8.)

PERFORMANCE TUNING

A tune-up requires more than changing spark plugs and filters. The ignition system, fuel system and battery checks are necessary to assure your tune-up will result in improved engine performance.

Mechanical Adjustments: There are several mechanical checks that should be performed in accordance with a tune-up. In addition to checking the cylinder compression, adjust the belts, tighten the manifold bolts and adjust the valves.

Ignition System: This system requires replacing and adjusting the contact points, rotor and cap (if equipped), verifying ignition advance and adjusting the timing. (Refer to Tune-up Specifications, page 3-8.)

Fuel System: Service and adjust the carburetor after the ignition system checks have been completed. Since the ignition adjustments have a direct effect on the carburetor performance, the fuel system checks should be performed after the ignition adjustments.

BATTERY CHECK

The battery, terminals, fluids and connectors should be inspected after the first 10 hours of operation and every 50 hours of operation thereafter.

NOTE: Electrical system in a marine environment require periodic attention. Continued use of a weak battery or dirty terminals can cause solenoid or starter problems.

WARNING: DO NOT overcharge a weak battery while it is in a boat. Remove and recharge in a ventilated area away from fuel vapors, sparks or flames.

- Examine the battery cable connectors for corrosion. If corrosion is evident, clean the terminals and connectors with a battery cleaning brush. Apply a thin coating of a multi-purpose lubricant to the terminals to prevent future corrosion.
- Examine the battery cables for cracks and broken or loose connections. Replace the cables or connectors if necessary.
- Check the levels of the battery fluid. If low, fill to proper level using distilled water. Make sure vent plugs are secure and tight.
- Check the top of the battery for cleanliness. Re-check vent plugs for tightness. If battery needs to be cleaned, use a solution of baking soda or diluted ammonia. Rinse solution off with fresh water.
- Check battery hold-down device. Make sure it is tight and is holding the battery in place without causing strain to the battery.

MECHANICAL ADJUSTMENTS

Drive Belts: Examine each belt for evidence of worn areas, tears or cracks. This examination should be performed during each tune-up or at least twice a year. When a belt needs replacing, be sure the replacement belt is the exact size and type as recommended by the engine manufacturer. The belt should be tight with a belt deflection of 1/4" (6.35mm) when a downward pressure is applied. This pressure should be applied midway between the circulation pump and alternator pulley. If the belt needs adjusting, loosen the alternator bracket and pivot bolts. Gently push the alternator away from the engine until the belt is tightened within specifications. Tighten the bracket and pivot bolts.

Check the tension on the drive belt. If this belt does

MECHANICAL ADJUSTMENTS (Continued)

not maintain proper tension, it will not allow the alternator to perform properly and will put a strain on the battery causing it to not hold a charge.

All belts should be checked after the first 10 hours of operation and every 50 hours of operation thereafter.

MANIFOLD BOLTS

The manifold bolts should be checked and tightened after the first 10 hours of operation and every 100 hours of operation. The sequence and torque specifications are detailed in the respective engine section.

COMPRESSION CHECK

During each engine tune-up the cylinder compression should be verified. Each cylinder should be checked one at a time.

- Using a compression gauge, insert it into the spark plug opening.
- Crank the engine and check compression.
- Look for a significant difference in readings between cylinders rather than individual cylinder readings.
- If there is a difference of 20 psi or more, that particular cylinder will require further examination.
- Insert a teaspoonful of oil into the spark plug opening of the low reading cylinder.
- Crank engine several times to allow the oil to be distributed in the cylinder.
- Check the compression again. If the reading is the same, this indicates a burned valve. If the reading goes up, this indicates worn rings.

SPARK PLUGS

In order to control your engine's performance and insure fuel economy, it is recommended that spark plugs be changed during each tune-up. Resistor type, copper core, tapered seat spark plugs are recommended for all Marine Power Engines. We recommend replacing your spark plugs with the following Marine Power parts:

Engine	Part Number
181 RX	0014-015
350 CA	0023-015G4
All others	0003-015

Normal or average service is assumed to be a mixture of idling, slow speed and high speed operation. Occasional or intermittent high speed operation is essential to good spark plug performance. It provides increased and sustained combustion heat that burns away excess oxide or carbon deposits that may have accumulated from frequent idling or slow speed operation.

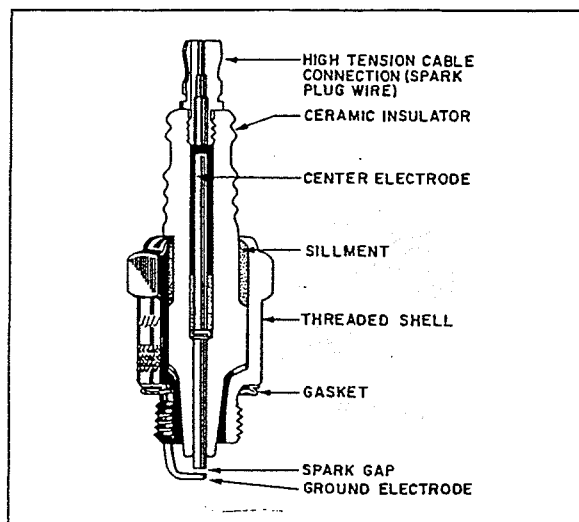
**SPARK PLUG MAINTENANCE**

It is recommended that spark plugs be replaced during each tune-up. However, if the plugs remain in good condition, they should be properly cleaned and gaped before re-installation.

- To remove spark plug wires, grasp the wire cap and gently twist and pull it loose from the plug.

CAUTION: DO NOT PULL spark plug wire from plug. This may damage cap which would make it unusable.

- With a spark plug wrench, remove the spark plug using caution so as not to damage the spark plug insulator.

SPARK PLUG MAINTENANCE (Continued)

- Clean and file flat the center electrode. Gap the plug (using a feeler gauge) to engine manufacturers specifications (Refer to "Tune-up Specifications, page 3-8.)
- Carefully re-install plugs and wires.

Spark plugs should be changed at least every 100 hours of operation.

SPARK PLUG WIRES

The spark plug wiring is a carbon impregnated cord conductor encased in a rubber jacket. The silicone



spark plug boots form a tight seal on the plugs.

The rubber jacket protects the wires from daily and seasonal weather conditions. However, spark plug wires should be examined for signs of brittle or worn areas. This should be done during pre-season engine check and during every tune-up.



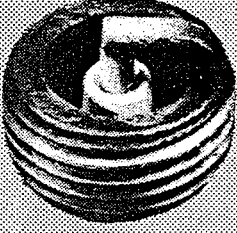

We recommend replacing spark plug wires with genuine Marine Power replacement wires:

<u>Engine</u>	<u>Part Number</u>
181	1112-000
250	1115-000F5
262	1111-000
All others	1110-000E5

SPARK PLUG ANALYSIS

Normal Operation	
	Small amount of deposits varying in color from light tan to a grayish color with slight electrode wear signifies a properly running engine.
Carbon Fouled	
	Dry, black, sooty deposits can be caused by excessive acceleration and deceleration or incorrect heat range of spark plug. If the plug's heat range is correct, a restricted flame arrestor, rich fuel mixture, malfunctioning choke, low compression or retarded timing may be the cause. If the condition exists on only one or two plugs, check the respective wires for deterioration or the distributor cap for cracks.
Oil Fouled	
	A wet, oily or gummy coating on the plug is indication of excessive oil consumption. This is considered normal on brand new or newly overhauled engines until the normal "break-in" period is met. Oil leakage past the rings or the valve guides is prevalent among older high time engines. A plugged PCV valve can also be the cause of the oil fouling.

SPARK PLUG ANALYSIS (Continued)

Ash Deposits	
	White or light-brown deposits on the side and/or center electrodes are usually caused by combustion of fuel additives or oil additives. Normally harmless, they can cause misfiring if build-up is excessive. This may be caused by worn valve guides if fuel additives are known not to have been used.
Detonation (Pre-ignition)	
	A broken electrode insulator or electrode usually signifies detonation. Instead of a controlled fuel burn, there is an explosion of the fuel causing dangerously high temperatures and pressures in the combustion chamber. Over-advanced ignition timing, poor carburetion, lean air/fuel mixture, low quality fuel, engine lugging or an increase in compression can cause detonation. If detonation is suspected, it must be corrected or serious engine damage will result.
	
	

IGNITION TIMING

The following ignition timing procedures are for Marine Power Engines equipped with Delco Electronic Ignition. Some engines may be equipped with MSTs (Microprocessor Spark Timing System). Refer to "MSTS", Section 5.

USING INITIAL TIMING CONNECTOR:

The initial timing connector is used in setting the initial engine timing on MARINE POWER engines. This connector by-passes the electronic spark timing of the engine and allows the initial timing to be adjusted by rotating the distributor. Use the following procedure (become familiar with entire procedure before beginning):

The ignition timing marks are located on the engine's front cover. A saw slot on the balancer indicates engine at (TDC) Top Dead Center. Adjust ignition timing as follows:

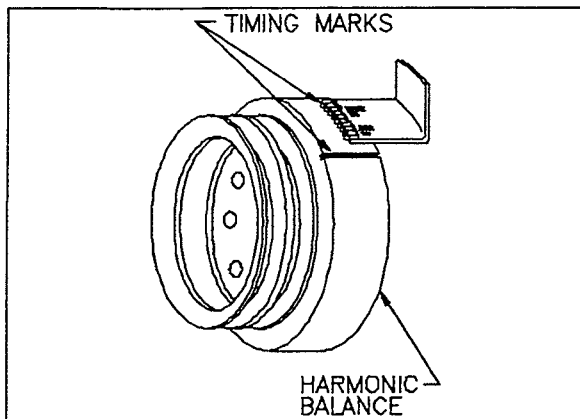

1. Connect a timing light to the number one (1) spark plug wire. Connect the timing light power lead to a 12 volt power source. (**DO NOT CONNECT TO 12 VOLTS ON ALTERNATOR**)

NOTE: To increase visibility of the saw slot in the harmonic balancer, mark the slot with a spot of white paint, fluorescent paint or soapstone.

2. Start engine and allow to warm to operating temperature. Bring engine to idle (650-800 RPM).
3. **WHILE ENGINE IS RUNNING**, install the initial timing connector supplied with your engine into the (4) terminal connector on distributor.
4. Loosen distributor clamp just enough to rotate distributor in place.
5. Secure the bare wire end of the initial timing connector to battery positive "+" voltage. (the most convenient location of this voltage is on the cranking motor solenoid.) If desired, a suitable clip, such as an alligator clip may be permanently attached to the bare wire end of the initial timing connector to hold it in place. While the lead is touching the voltage source, the frozen electronic timing is "Frozen".
6. Attach timing light according to the manufacturers' instructions.
7. Rotate distributor to set mechanical timing.

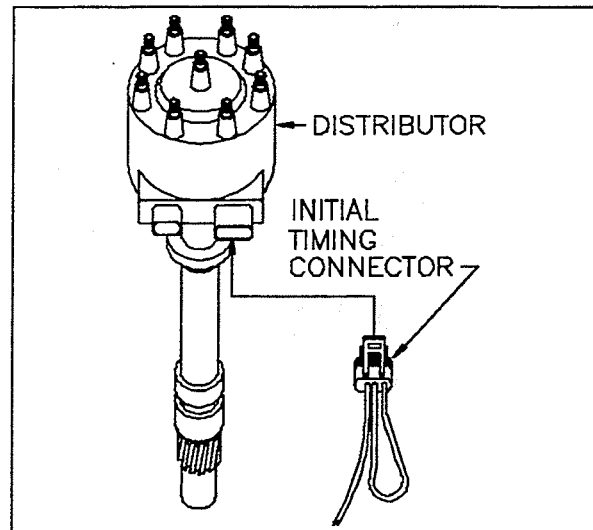

8. Tighten distributor clamp to hold in position when initial timing is obtained.
9. Recheck timing.
10. Detach initial timing connector from distributor.
11. Check total timing. This must not exceed 24 degrees at 4000 RPM for 181/262 CID engines, 26 degrees for 305/350 CID engines and 30 degrees for 454/502 CID engines.
12. Disconnect and remove timing light.

FUEL SYSTEM SERVICE

GENERAL INFORMATION

Fuel system service requires maintenance of the fuel filter, water separator filter and the flame arrestor. The carburetor requires the proper mixture of fuel and air to perform at its best.

The fuel filter is located at the fuel inlet of the carburetor. This filter should be changed after every 100 hours of operation or at least once a year. Be sure to change the gasket under the nut to prevent fuel leakage.

The fuel water separator should be changed after every 100 hours of operation or at least once a year.

The flame arrestor should be cleaned after every 100 hours of operation or at least once a year.

CARBURETOR

Proper carburetor adjustments are crucial to engine performance. Restrictions in the carburetor passages (dirt and gummy build-up) will limit the flow of air and/or fuel through the carburetor. These restrictions will create poor engine performance such as acceleration hesitation, lean operating conditions and lack of power.

During normal engine operation, the carburetor control linkage may sustain wear. If this linkage becomes worn, it will change the fuel and air mixture entering the carburetor. These changes will directly affect fuel economy and engine performance.

To correct this situation, carburetor adjustments may be required. If the carburetor is still in good condition, adjustments may be made to correct the problem. However, if the carburetor is not in good condition, adjustments would not be effective and the carburetor may require rebuilding.

To Adjust Idle Mixture: Make a preliminary adjustment by turning the idle mixture adjustment screws inward until they barely make contact with their seats, then

back the screw out the same number of turns. **DO NOT turn these screws tightly against their seats. This will damage adjustment screws.** Disconnect the throttle cable and start the engine. Run engine at idle speed.

CAUTION: Before starting engine, make sure water is circulating through engine to prevent damage to water pumps.

In order to properly adjust the idle mixture, use of a vacuum gauge is recommended. On most engines, a 3/8" NPT pipe plug must be removed to install the gauge. This plug is located behind the carburetor at the rear of the intake manifold. (Remember to re-install the pipe plug when adjustments have been completed). Each idle mixture screw (2) must be adjusted to obtain the desired high and steady vacuum gauge readings.

These adjustments may be made without using a vacuum gauge. To find the smoothest running idle, turn the adjustment screws in until engine speed begins to drop. Back the screw out until the idle speed increases, continue backing screw out until idle speeds drops again. Adjust the screw halfway between the two points. This should provide an acceptable idle mixture setting. Repeat this procedure with the other adjustment screw.

In some instances, these adjustments may result in an increased idle. Readjust the idle speed screws to obtain the specified idle rpm. To obtain the proper idle speed when gear is in forward, shift the gear into forward and readjust the idle speed screw to desired idle.

After the idle mixture has been completed, stop the engine. Install the throttle cable and check to be sure the throttle valves are in the full open position when the throttle lever is in full forward position. With the throttle valves fully opened, turn the wide open throttle stop adjusting screw clockwise until the screw touches the throttle lever. The set nut should be tightened to prevent the adjustment screw from turning. Return the shift lever to idle position and neutral gear. The idle-stop screw should be positioned against its stop.

VACUUM GAUGES

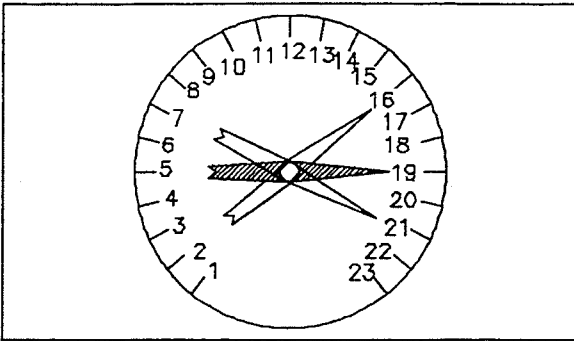

At idle, needle movement above and below the normal indication implies too rich or too lean of a mixture setting.

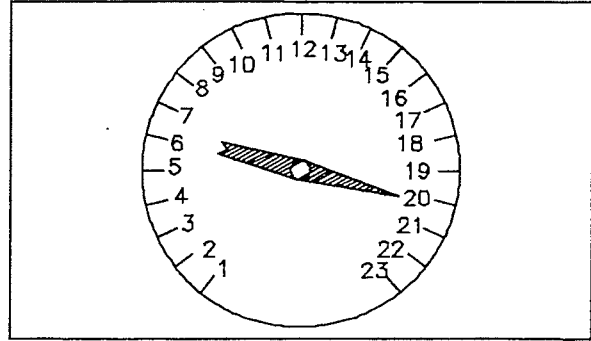

At idle, a good reading is between 15-21 inches of vacuum.

TUNE-UP SPECIFICATIONS

ENG CID (L)	MARINE POWER PART # (SPARK PLUGS)	PLUG GAP	POINT GAP*	POINT DOWELL	TIMING INITIAL	TIMING TOTAL @ 4000 RPM	MSTS TOTAL
181 (3.0L)	0014-015 (MR42LTS)	0.035* (0.89 mm)	0.022* (0.56mm)	24°	0° BTDC	24° BTDC	
250 (4.1L)	0003-015 (MR43T)	0.035* (0.89 mm)	0.016-0.019* (0.41-0.48 mm)	32°	10° BTDC	32° BTDC	
262 (4.3L)	0003-015 (MR43T)	0.035* (0.89 mm)	N/A	N/A	0° BTDC	24° BTDC	
305 (5.0L)	0003-015 (MR43T)	0.035* (0.89 mm)	N/A	N/A	8° BTDC	26° BTDC	
350 (5.7L)	0003-015 (MR43T)	0.035* (0.89 mm)	N/A	N/A	8° BTDC	26° BTDC	
350 CA (5.7L)	0023-015G4 (MR43LTS)	0.045* (1.14 mm)	N/A	N/A	10° BTDC	28° BTDC	
454 (7.4L)	0003-015 (MR43T)	0.035* (0.89 mm)	N/A	N/A	12° BTDC	30° BTDC	37° BTDC
502 (8.2L)	0003-015 (MR43T)	0.035* (0.89 mm)	N/A	N/A	12° BTDC	30° BTDC	37° BTDC
540 (8.8L)	0003-015 (MR43T)	0.035* (0.89 mm)	N/A	N/A	12° BTDC	30° BTDC	37° BTDC

* IF APPLICABLE

FIRING ORDER

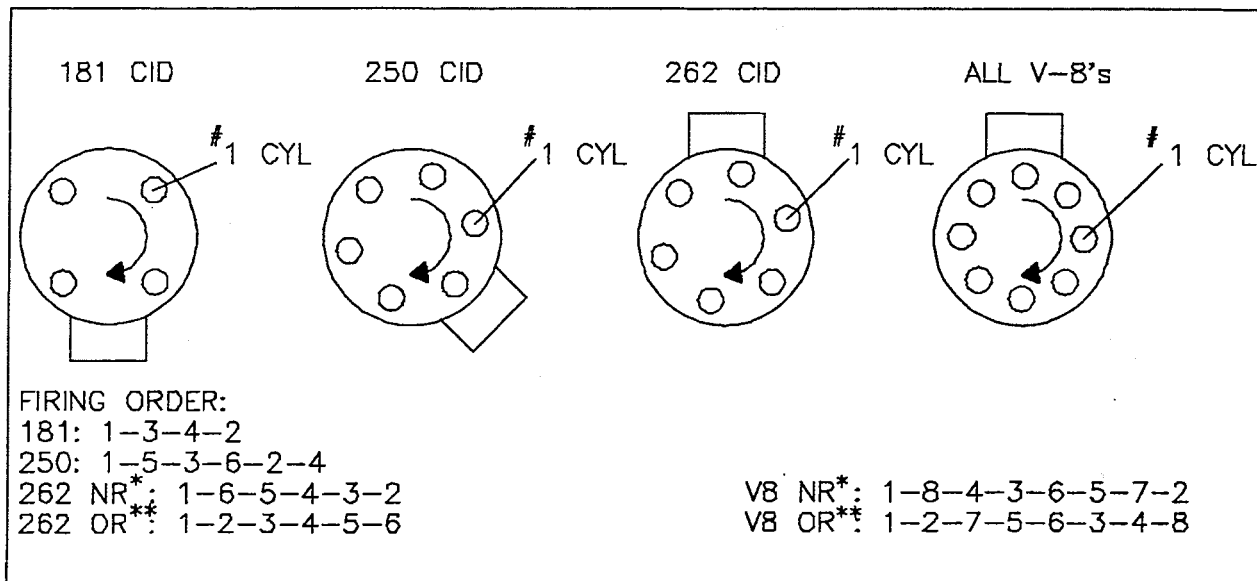

* NORMAL ROTATION ** OPPOSITE ROTATION

OIL DRAIN AND CHANGE

It is advisable to bring engine up to operating temperatures before changing oil. This allows any foreign matter to be in suspension in the oil and to be drained out of the engine.

CAUTION: Engine oil is extremely hot at engine operating temperatures. Exercise caution to avoid burns to the body and face or eyes by wearing rubberized gloves and eye protection.

NOTE: The following instructions for oil change requires a Marine Power E-Z Oil Drain Kit which is included with each Sportpac and Enpac engines with stamped steel oil pans.

1. Locate the E-Z Oil Drain line coming from the bottom of the engine and remove the plug from the free end. Drain the oil into a suitable container and replace the E-Z Oil Drain line plug and tighten.

2. Locate the oil filter on the starboard side of the engine and loosen it with a filter band wrench or cap wrench.
3. Wearing gloves (to protect from hot surfaces), spin the filter off by hand. NOTE: Insure the old rubber gasket is removed with the filter.
4. Coat the rubber gasket on the new oil filter with clean motor oil.
5. Wipe the machined gasket contact surface on the engine clean and install a new oil filter.
6. Tighten 3/4 turn after the gasket contacts the surface.

We recommend using genuine Marine Power replacement oil filters.

Engine Model	Filter Part #
SPORTPAC	0904-000
ENPAC	0905-000

**DISPOSE OF USED
ENGINE OIL AND FILTER PROPERLY**

ENGINE WILL NOT START ENGINE WILL NOT SPIN STARTER WILL NOT CRANK ENGINE		
CAUSE	REMEDY	RECOMMENDATIONS
• LOW BATTERY OR CONNECTION LOOSE	• CHECK/CHARGE/REPLACE	• CHECK FOR BILGE FUMES TO AVOID FIRE OR EXPLOSION
• FAULTY BATTERY CABLE	• CHECK/REPLACE	• CHECK FOR BILGE FUMES TO AVOID FIRE OR EXPLOSION
• NEUTRAL SAFETY SWITCH WIRING IMPROPERLY ADJUSTED OR FAULTY	• ADJUST/CHECK/REPLACE	• SPRAY LUBRICANT BETWEEN SELECTOR VALVE HANDLE & CASING. BEARING MUST BE FREE FOR MOVEMENT
• NEUTRAL SAFETY SWITCH WIRING CIRCUIT INCOMPLETE	• INSPECT/CORRECT	• DISCONNECT NEGATIVE BATTERY CABLE BEFORE SERVICING
• SHIFT CONTROL IN GEAR	• MOVE SHIFT TO NEUTRAL	
• WIRING HARNESS PLUGS IMPROPERLY INDEXED	• CHECK/RE-INDEX	• USE CORROSION PROTECTANT LUBRICATE BETWEEN PLUGS. A #20 CLAMP WILL KEEP PLUGS FROM SEPARATING.
• CIRCUIT BREAKER TRIPPED OR FAULTY	• RESET/REPLACE	• CIRCUIT BREAKER LOCATED ON COMPONENT BRACKET
• NO VOLTAGE TO KEYSWITCH OR FAULTY KEYSWITCH	• TEST/REPLACE	• CHECK CONNECTIONS BETWEEN TERMINAL AND WIRE FOR CRIMPING
• FAULTY RELAY SOLENOID	• TEST/REPLACE	• CHECK CONNECTIONS BETWEEN TERMINAL AND WIRE FOR CRIMPING
• FAULTY STARTER SOLENOID	• TEST/REPLACE	
• FAULTY STARTER	• TEST/REPLACE/REPAIR	
• STARTER PINION & RING GEAR LOCKED OR BROKEN	• CHECK FOR HYDRAULIC LOCK TEST/REMOVE/REPLACE	
• CRANKSHAFT BINDING	• REMOVE DRIVE CHECK DAMPER ASSEMBLY	
• INSTRUMENT PANEL 20 AMP FUSE BLOWN	• CHECK/REPLACE	• IF FUSE BLOWS AGAIN, TROUBLESHOOT SYSTEM TO DETERMINE CAUSE

ENGINE WILL NOT START ENGINE WILL NOT SPIN STARTER WILL NOT CRANK ENGINE		
CAUSE	REMEDY	RECOMMENDATIONS
<ul style="list-style-type: none"> • HYDRAULIC LOCK • MAJOR INTERNAL ENGINE DAMAGE 	<ul style="list-style-type: none"> • REMOVE SPARK PLUGS/SPIN ENGINE/DETERMINE CAUSE OF WATER IN CYLINDER/TEST • INSPECT/REPAIR/REPLACE 	<ul style="list-style-type: none"> • IF HYDRAULIC LOCK OCCURS, REMOVE SPARK PLUGS, SPRAY LUBRICANT IN PLUG HOLES. LET SET FOR 30 MINUTES THEN CRANK ENGINE WITH PLUGS OUT OF HOLES. NOTE: DO NOT STAND CLOSE TO SPARK PLUG HOLES WHEN CRANKING ENGINE; WATER MAY BE FORCED OUT OF HOLES AT HIGH PRESSURE.
<p>RECOMMENDATIONS:</p> <ul style="list-style-type: none"> • ALWAYS BEGIN WITH THE MOST COMMON AND EASY STEPS. THIS WILL HELP YOU REMEDY THE PROBLEM WITHOUT INVOLVING EXTENSIVE DIAGNOSTIC TIME. 		

ENGINE CRANKS BUT WILL NOT START		
CAUSE	REMEDY	RECOMMENDATIONS
<ul style="list-style-type: none"> • ELECTRIC FUEL PUMP FAULTY • FAULTY SAFETY OIL PRESSURE SWITCH • INSUFFICIENT FUEL SUPPLY TO CARBURETOR OR FUEL PUMP • FAULTY KEYSWITCH • INSUFFICIENT CRANKING RPM'S • INSUFFICIENT VOLTAGE AT COIL 	<ul style="list-style-type: none"> • CHECK/REPLACE • CHECK/REPLACE • CHECK FUEL SUPPLY SHUTOFF VALVE, FUEL LINE RESTRICTION, AIR, WATER SEPARATOR • TEST/REPLACE • CHECK FOR CRANK BINDING CHECK STARTER CHECK BATTERY • CHECK VOLTAGE AT COIL WITH IGNITION SWITCH ON 	<ul style="list-style-type: none"> • MAKE SURE THERE IS 12 VOLTS TO FUEL PUMP • DO NOT USE TEFLON TAPE. IT MAY CAUSE AN IMPROPER GROUND. • BE AWARE OF DANGEROUS GASOLINE VAPORS. USE APPROPRIATE PRECAUTIONS.

ENGINE CRANKS BUT WILL NOT START (Continued)		
CAUSE	REMEDY	RECOMMENDATIONS
• ENGINE FLOODING	• ADVANCE THROTTLE TO WIDE OPEN THROTTLE & CRANK, RETURN THROTTLE TO NORMAL POSITION AFTER STARTING	• CHECK ROTOR & WIRE CONTACT ON UNDERSIDE OF CAP FOR MOISTURE OR CRACKS
• NO FIRE AT SPARK PLUGS	• CHECK/TEST DISTRIBUTOR, DISTRIBUTOR CAP & ROTOR	• REFER TO OWNERS MANUAL FOR PROPER PLUG TYPE AND CLEANING INSTRUCTIONS
• FOULED SPARK PLUGS	• CLEAN/REPLACE	• REFER TO OWNERS MANUAL FOR PROPER FIRING ORDER
• FIRING ORDER INCORRECT	• CHECK/CORRECT	• CHECK TDC ON CRANKSHAFT, COMPARE WITH ROTOR. ROTOR SHOULD BE AT #1 PLUG WIRE ON CAP
• DISTRIBUTOR INSTALLED INCORRECTLY	• CHECK/REMOVE/INSTALL	• REMOVE CAP AND CRANK ENGINE TO SEE IF ROTOR IS SPINNING
• CARBURETOR FAULTY	• INSPECT NEEDLE & SEAT, REPAIR/REPLACE	
• ENGINE TURNS IN WRONG DIRECTION	• REPLACE STARTER WITH CORRECT ROTATION	
• TIMING CHAIN OR DISTRIBUTOR SHAFT SHEARED	• TEST/CHECK/REPLACE	
RECOMMENDATIONS: • ALWAYS REMEMBER THE THREE (3) ITEMS NEEDED FOR AN ENGINE TO START AND RUN: (1) COMPRESSION (2) IGNITION (3) FUEL		

ENGINE STARTS AND STOPS		
CAUSE	REMEDY	RECOMMENDATIONS
• INSUFFICIENT FUEL SUPPLY	• CHECK VALVES, FITTINGS, FILTERS AND FUEL LEVEL/REFILL	
• COLD ENGINE	• UPON ENGINE START, HOLD ENGINE @ 1000 RPM	
• ENGINE IDLE TOO LOW	• ADJUST	• ADJUSTMENT @ 750 RPM (IDLE)
• CHOKE ADJUSTMENT INCORRECT	• ADJUST	• CHOKE ADJUSTMENT MUST BE FOR CLIMATE & CLIMATE CHANGES

ENGINE STARTS AND STOPS		
CAUSE	REMEDY	RECOMMENDATIONS
<ul style="list-style-type: none"> • FAULTY KEYSWITCH • DIRT AND/OR WATER IN CARBURETOR • ENGINE TO PANEL WIRING INCORRECT • INTERNAL ENGINE FAILURE 	<ul style="list-style-type: none"> • TEST/REPLACE • CLEAN/REPLACE • CHECK/CORRECT • CHECK/REPAIR, SEEK QUALIFIED HELP 	<ul style="list-style-type: none"> • INLINE FILTER TO CARBURETOR

LOW SPEED MISS OR ROUGH IDLE		
CAUSE	REMEDY	RECOMMENDATIONS
<ul style="list-style-type: none"> • FIRING ORDER INCORRECT • CHOKE ADJUSTMENT INCORRECT OR FAULTY • FAULTY SPARK PLUG AND/OR WIRE • CONTAMINANTS IN CARBURETOR • IGNITION TIMING INCORRECT • STUCK, BURNT, WARPED, BENT VALVES AND/OR PUSH RODS & VALVE SPRINGS 	<ul style="list-style-type: none"> • CHECK/CORRECT • TEST/ADJUST/REPLACE • TEST/REPLACE • CLEAN/ADJUST/REPLACE • ADJUST • CHECK/ADJUST/REPLACE, CHECK FOR LOW COMPRESSION & LOW VACUUM 	<ul style="list-style-type: none"> • REFER TO OWNERS MANUAL FOR CORRECT FIRING ORDER • CHOKE MUST BE ADJUSTED TO CLIMATE & CLIMATE CHANGE • REFER TO OWNERS MANUAL FOR TIMING PROCEDURES

HIGH SPEED MISS		
CAUSE	REMEDY	RECOMMENDATIONS
<ul style="list-style-type: none"> • WATER IN FUEL • CLOGGED FUEL FILTER • INSUFFICIENT FUEL SUPPLY 	<ul style="list-style-type: none"> • INSPECT/CLEAN/REPLACE • PRIMARY AND SECONDARY, REPLACE • TEST/CORRECT/REFILL 	<ul style="list-style-type: none"> • CHECK FOR LEAKAGE IN ENGINE HATCH, FUEL TANK • ALWAYS DISCONNECT BATTERY CABLES WHEN HANDLING FUEL RELATED ITEMS TO PREVENT HARMFUL SPARKS • CONNECT A FUEL PRESSURE GAUGE TO THE FUEL PUMP, CHECK FUEL LINES/FILTER

HIGH SPEED MISS (Continued)		
CAUSE	REMEDY	RECOMMENDATIONS
<ul style="list-style-type: none"> • FAULTY SPARK PLUGS OR PLUG WIRES • FAULTY DISTRIBUTOR, MODULE AND/OR COIL • LOOSE IGNITION CONNECTION • FAULTY KEY SWITCH • INTERMITTENT VOLTAGE AT COIL • INCORRECT TIMING • IGNITION TIMING INITIAL & TOTAL ADVANCE INCORRECT • FUEL SUPPLY TUBE IN FUEL TANK CLOGGED • POOR FUEL QUALITY • DISTRIBUTOR CAP FAULTY • AIR LEAK IN FUEL SUPPLY HOSES OR FILTERS • FAULTY TACHOMETER • DETONATION • FAULTY FUEL PUMP • INTERMITTENT VOLTAGE AT FUEL PUMP 	<ul style="list-style-type: none"> • TEST/REPLACE • CHECK/TEST/REPAIR/REPLACE • CHECK IGNITION CIRCUIT • CHECK/TEST/REPLACE • INSPECT/TEST/REPAIR • CHECK/ADJUST • CHECK IGNITION & TOTAL ADVANCE • INSPECT/CLEAN • DRAIN/REFILL • TEST/REPLACE • CHECK/REPAIR • CHECK/TEST/REPLACE • DO NOT CONTINUE TO OPERATE ENGINE, SEEK QUALIFIED HELP • TEST/REPLACE • CHECK/REPAIR 	<ul style="list-style-type: none"> • REFER TO OWNERS MANUAL FOR CORRECT SPARK PLUGS • CHECK WIRE CONNECTION • CHECK FOR LOOSE TERMINAL ON KEY SWITCH; LOOSE HARNESS PLUG FROM ENGINE TO HARNESS • REFER TO OWNERS MANUAL FOR CORRECT TIMING & INSTRUCTIONS • REFER TO OWNERS MANUAL FOR CORRECT TIMING & INSTRUCTIONS • REFER TO PARTS LIST FOR PROPER DISTRIBUTOR PARTS • CHECK TO MAKE SURE 12 VOLTS TO FUEL PUMP • CHECK FOR LOOSE WIRE CONNECTION

LOW POWER		
CAUSE	REMEDY	RECOMMENDATIONS
<ul style="list-style-type: none"> • HULL FOULING BOTTOM GROWTH 	<ul style="list-style-type: none"> • CHECK/CLEAN 	<p>* SEE HIGH SPEED MISS</p>

LOW POWER (Continued)		* SEE HIGH SPEED MISS
CAUSE	REMEDY	RECOMMENDATIONS
<ul style="list-style-type: none"> • DEBRIS ON SHAFT OR PROP • INCORRECT OR BENT PROPELLER • BOAT IMPROPERLY LOADED • FAULTY STRUT BEARING • PROPELLER SHAFT ALIGNMENT • PACKING NUT TOO TIGHT • TRIM TABS INOPERATIVE • RUDDER ALIGNMENT (DUAL INSTALLATIONS) • IMPROPER TRANSMISSION RATIO • THROTTLE NOT OPENING TO FULL WIDE OPEN POSITION • EXCESSIVE WATER IN BOAT • INSUFFICIENT AIR SUPPLY TO ENGINE • TRANSMISSION OPERATING IN REVERSE FOR FORWARD • INTERNAL ENGINE BINDING • MARINE GEAR FAILURE 	<ul style="list-style-type: none"> • CHECK • CHECK/CORRECT • CHECK WEIGHT DISTRIBUTION • CHECK/REPLACE • CHECK/ADJUST • ADJUST • TEST/CORRECT • CHECK ALIGNMENT • CHECK/CORRECT • CHECK/ADJUST • CHECK/CORRECT • INSPECT/CHECK/CORRECT • SEE TRANSMISSION MANUAL • CHECK/ROTATE BY HAND • CHECK/CORRECT 	<ul style="list-style-type: none"> • BOAT MUST BE HAULED OUT OF WATER FOR REPLACEMENT

EXCESSIVE OIL CONSUMPTION		
CAUSE	REMEDY	RECOMMENDATIONS
<ul style="list-style-type: none"> • EXTERNAL LEAK • EXCESSIVE OIL USED IN CRANKCASE 	<ul style="list-style-type: none"> • CHECK/CORRECT • INSPECT/CORRECT 	<ul style="list-style-type: none"> • CAUTION: OIL MAY BE HOT!

EXCESSIVE OIL CONSUMPTION (Continued)		
CAUSE	REMEDY	RECOMMENDATIONS
<ul style="list-style-type: none"> • OIL-FUEL DILUTED • EXCESSIVE RPM FOR EXTENDED PERIODS • INCORRECT OIL VISCOSITY OR GRADE • INCORRECT DIPSTICK • EXCESSIVE OIL TEMPERATURE • DEFECTIVE OIL COOLER • REMOTE OIL LINES INCORRECTLY INSTALLED • ENGINE BREATHER TUBES BLOCKED • INTERNAL ENGINE PROBLEM 	<ul style="list-style-type: none"> • INSPECT CARBURETOR & FUEL PUMP • LOWER CRUISE RPM • SEE OPERATIONS MANUAL • INSPECT/REPLACE • REPLACE OIL COOLER • TEST/REPLACE • CHECK/CORRECT • INSPECT/CLEAN • SEEK QUALIFIED HELP 	<ul style="list-style-type: none"> • MAKE SURE ENGINE IS RUNNING AT CORRECT TEMPERATURE; CHECK CHOKE ADJUSTMENT; CHECK FLOAT LEVEL ON CARBURETOR; CHECK GASKET BETWEEN FUEL PUMP & ENGINE FOR POSSIBLE RUPTURE • USE RECOMMENDED GRADE OF OIL • DRAIN OIL; REFILL WITH CORRECT AMOUNT OF OIL, COMPARE WITH DIPSTICK; REFER TO OWNERS MANUAL • REFER TO OWNERS MANUAL FOR CORRECT ROUTING. ALLOW ENGINE TO COOL BEFORE ROUTING.

EXCESSIVE FUEL CONSUMPTION		
CAUSE	REMEDY	RECOMMENDATIONS
<ul style="list-style-type: none"> • CHOKE NOT FULLY DISENGAGING • FLAME ARRESTOR DIRTY • CARBURETOR DEFECTIVE OR CONTAMINATED • SPARK PLUGS AND/OR GAP INCORRECT 	<ul style="list-style-type: none"> • CHECK/ADJUST • CHECK/CLEAN • TEST/CLEAN/ADJUST • CHECK/REPLACE 	<ul style="list-style-type: none"> • SPRAY LUBRICANT ON ALL CHOKE LINKAGE; CHECK FOR BENT LINKAGE • SOAK IN CARBURETOR TYPE CLEANER • CHECK FUEL SYSTEM FOR SOURCE OF DIRT & CONTAMINATES

EXCESSIVE FUEL CONSUMPTION (Continued)		
CAUSE	REMEDY	RECOMMENDATIONS
<ul style="list-style-type: none"> • CHOKE NOT FULLY DISENGAGING • FLAME ARRESTOR DIRTY • CARBURETOR DEFECTIVE OR CONTAMINATED • SPARK PLUGS AND/OR GAP INCORRECT • INCORRECT INITIAL AND TOTAL ADVANCE TIMING • POOR FUEL QUALITY • INCORRECT PROPELLER SIZE 	<ul style="list-style-type: none"> • CHECK/ADJUST • CHECK/CLEAN • TEST/CLEAN/ADJUST • CHECK/REPLACE • TEST/ADJUST • REPLACE • CHECK/REPLACE 	<ul style="list-style-type: none"> • SPRAY LUBRICANT ON ALL CHOKE LINKAGE; CHECK FOR BENT LINKAGE • SOAK IN CARBURETOR TYPE CLEANER • CHECK FUEL SYSTEM FOR SOURCE OF DIRT & CONTAMINANTS • REFER TO OWNERS MANUAL FOR INSTRUCTIONS

ENGINE RUNS HOT		
CAUSE	REMEDY	RECOMMENDATIONS
<ul style="list-style-type: none"> • WATER SHUT OFF VALVE FAULTY OR NOT FULLY OPEN • INCORRECT PURGE PROCEDURE OF CIRCULATING PUMP ON FRESHWATER COOLED ENGINES WITH REMOVABLE PLUG IN CIRCULATION PUMP • ERRONEOUS GAUGE READINGS • BLOCKED WATER INTAKE SCOOP • SEA STRAINER DIRTY • TRANSMISSION COOLER BLOCKED • ENGINE OIL COOLER BLOCKED 	<ul style="list-style-type: none"> • INSPECT/REPLACE • SEE "OPERATIONS MANUAL" FOR PROCEDURE • CONFIRM TEMPERATURE WITH MECHANICAL TYPE GAUGE • INSPECT/CLEAN • INSPECT/CLEAN • INSPECT/CLEAN • INSPECT/CLEAN 	<ul style="list-style-type: none"> • VALVE HANDLE MUST BE TIGHT; IF LOOSE, VIBRATION WILL OCCUR • CAUTION: WATER WILL BE HOT! • HAUL BOAT OUT OF WATER FOR PROPER CLEANING • IF SEA STRAINER IS DIRTY, CHECK OIL COOLER • MAKE SURE WATER VALVE IS SHUT BEFORE REMOVING HOSE • MAKE SURE WATER VALVE IS SHUT BEFORE REMOVING HOSE

ENGINE RUNS HOT (Continued)		
CAUSE	REMEDY	RECOMMENDATIONS
<ul style="list-style-type: none"> • AIR LEAK IN WATER HOSE AND FITTINGS TO SEA PUMP • COLLAPSING, FAULTY, KINKED, INCORRECT WATER INLET HOSE • IMPROPER WATER INLET SIZE IN BOAT HULL • INCORRECT MUFFLER DESIGN, TOO MUCH BACK PRESSURE • EXHAUST HOSE OR CLAMP RESTRICTING FLOW FROM RISER DUMPS • SEA PUMP COVER LOOSE • SEA PUMP IMPELLER FAILURE • HOT WATER HEATER INCORRECTLY PLUMBED • AIR DELIVERED TO INLET SCOOP FROM HULL DESIGN • EXHAUST RISER GASKET FAILURE • HEAT EXCHANGER INTERNALLY DIRTY • CAM IN SEA PUMP OR SEA PUMP HOUSING WORN • EXHAUST RISER INTERNALLY BLOCKED • HEAT EXCHANGER BLOCKED ON WATER INLET SIDE • BELT SLIPPING ON CIRCULATION PUMP • INCORRECT OR FAULTY THERMOSTAT 	<ul style="list-style-type: none"> • INSPECT/CORRECT • REPLACE • INSPECT/REPLACE • CHECK/CORRECT • INSPECT/CORRECT • INSPECT/TIGHTEN • INSPECT/REPLACE • INSPECT/CORRECT • INSPECT/CORRECT • INSPECT/REPLACE • CLEAN/REPLACE • INSPECT/REPLACE • INSPECT/CLEAN/REPLACE • INSPECT/CLEAN • INSPECT/ADJUST/REPLACE • INSPECT/TEST/REPLACE 	<ul style="list-style-type: none"> • ALWAYS USE WIRE REINFORCED HOSE ON PUMP INTAKE SIDE • INLET HOSE SHOULD BE SAME SIZE AS PUMP INLET AND OUTLET • CAUTION: WATER MAY BE HOT! • REMOVE TANK AND HAVE CLEANED AT RADIATOR SHOP • REMOVE IMPELLER; CHECK FOR WEAR IN HOUSING • REMOVE END CAPS TO INSPECT TUBE FOR BLOCKAGE • LOOK FOR WORN BELT ON CIRC PUMP; PUMP HARD TO TURN • REFER TO OWNERS MANUAL FOR CORRECT THERMOSTAT

ENGINE RUNS HOT (Continued)		
CAUSE	REMEDY	RECOMMENDATIONS
<ul style="list-style-type: none"> • HEAD GASKET FAILURE 	<ul style="list-style-type: none"> • REPLACE/CHECK FOR WARPED HEADS/REPLACE 	<ul style="list-style-type: none"> • LOOSING COOLANT AND/OR AIR BUBBLES IN HEAT EXCHANGER WILL BE SIGNS OF A BLOWN HEAD GASKET
<ul style="list-style-type: none"> • IGNITION TIMING: INITIAL AND TOTAL 	<ul style="list-style-type: none"> • CHECK/TEST/ADJUST 	<ul style="list-style-type: none"> • REFER TO OWNERS MANUAL FOR TIMING INSTRUCTIONS
<ul style="list-style-type: none"> • ENGINE INSTALLED INCORRECTLY 	<ul style="list-style-type: none"> • CHECK/CORRECT 	
<ul style="list-style-type: none"> • INDEXING OF BAFFLE ENDS 	<ul style="list-style-type: none"> • CHECK/CORRECT 	<ul style="list-style-type: none"> • REMOVE END CAPS TO CHECK BAFFLES
<ul style="list-style-type: none"> • ANTIFREEZE MIXTURE 	<ul style="list-style-type: none"> • CHECK/CORRECT 	<ul style="list-style-type: none"> • REFER TO OWNERS MANUAL FOR CORRECT MIXTURE
<ul style="list-style-type: none"> • RADIATOR CAP NOT SEALING PROPERLY 	<ul style="list-style-type: none"> • CHECK/REPLACE 	<ul style="list-style-type: none"> • INCORRECT CAP WILL CAUSE LOSS OF COOLANT. REPLACE WITH A DUAL SEAL, 7 LB. CAP

ENGINE RUNS COLD		
CAUSE	REMEDY	RECOMMENDATIONS
<ul style="list-style-type: none"> • INCORRECT OR FAULTY THERMOSTAT 	<ul style="list-style-type: none"> • INSPECT/TEST/REPLACE 	<ul style="list-style-type: none"> • BEWARE OF HOT WATER UNDER PRESSURE
<ul style="list-style-type: none"> • ERRONEOUS GAUGE READINGS 	<ul style="list-style-type: none"> • CONFIRM TEMPERATURE WITH MECHANICAL TYPE GAUGE 	

LOW OIL PRESSURE		
CAUSE	REMEDY	RECOMMENDATIONS
<ul style="list-style-type: none"> • INSUFFICIENT OIL IN CRANKCASE 	<ul style="list-style-type: none"> • ADD CORRECT GRADE AND VISCOSITY, CHECK ENTIRE ENGINE FOR LEAKS 	<ul style="list-style-type: none"> • OIL PICK-UP TUBE MAY BE GETTING AIR, THIS WILL CAUSE DAMAGE
<ul style="list-style-type: none"> • ERRONEOUS GAUGE READINGS 	<ul style="list-style-type: none"> • CHECK PRESSURE WITH MECHANICAL TYPE GAUGE 	
<ul style="list-style-type: none"> • EXCESSIVE OIL IN CRANKCASE 	<ul style="list-style-type: none"> • REMOVE OIL TO BRING TO PROPER LEVEL 	<ul style="list-style-type: none"> • OIL WILL FOAM AND ALLOW OIL PICK-UP TO GET AIR

LOW OIL PRESSURE		
CAUSE	REMEDY	RECOMMENDATIONS
<ul style="list-style-type: none"> • EXCESSIVE OIL IN CRANKCASE • INCORRECT DIPSTICK • IMPROPER VISCOSITY OR DILUTED OIL • OIL LINE POSITION AND ROUTING • INTERNAL ENGINE DEFECT • FAULTY CARBURETOR • OIL LINES KINKED • EXCESSIVE OIL TEMPERATURE 	<ul style="list-style-type: none"> • REMOVE OIL TO BRING TO PROPER LEVEL • CHANGE • CHANGE OIL & FILTER • CHECK • SEEK QUALIFIED HELP • CHECK/REPAIR • STRAIGHTEN LINES • CHECK OIL COOLER 	<ul style="list-style-type: none"> • OIL WILL FOAM AND ALLOW OIL PICK-UP TO GET AIR • DRAIN OIL AND REFILL WITH CORRECT AMOUNT OF OIL; CHECK DIPSTICK READING; REFER TO OWNERS MANUAL • REFER TO OWNERS MANUAL FOR CORRECT GRADE OF OIL • REFER TO OWNERS MANUAL FOR CORRECT OIL LINE ROUTING • REFER TO DEALER DIRECTORY FOR AUTHORIZED DEALER • FUEL WILL DILUTE OIL AND CAUSE OIL PRESSURE LOSS • MAKE SURE WATER VALVE IS SHUT BEFORE REMOVING OIL COOLER

WATER IN CYLINDER OR BASE		
CAUSE	REMEDY	RECOMMENDATIONS
<ul style="list-style-type: none"> • OPERATOR ERROR • EXHAUST RESTRICTED OR BLOCKED • ENGINE AND EXHAUST TOO LOW IN BOAT • DEFECTIVE EXHAUST RISER GASKET AND/OR PLATES • DEFECTIVE EXHAUST MANIFOLD AND/OR RISER • CYLINDER HEAD GASKET LEAK 	<ul style="list-style-type: none"> • SEE "BOATERS BEWARE" IN ENGINE OWNER'S MANUAL • REPAIR/REPLACE • REDESIGN AND ADD RISER SPACERS • REPLACE • REPLACE • REPLACE/CHECK FOR WARPED HEADS/REPLACE 	<ul style="list-style-type: none"> • REFER TO DEALER DIRECTORY FOR AUTHORIZED DEALER

WATER IN CYLINDER OR BASE (Continued)		
CAUSE	REMEDY	RECOMMENDATIONS
<ul style="list-style-type: none"> • CRACKED BLOCK OR CYLINDER HEAD • INTAKE MANIFOLD GASKET LEAK • INCORRECT ENGINE ROTATION 	<ul style="list-style-type: none"> • REPLACE • REPLACE • CHECK 	
<p>RECOMMENDATIONS:</p> <ul style="list-style-type: none"> • WHEN WATER IS FOUND IN ENGINE CASE, IT IS USUALLY THE RESULT OF A SERIOUS PROBLEM. A MARINE POWER SERVICING DEALER SHOULD BE INVOLVED. 		

BATTERY WILL NOT COME UP TO CHARGE		
CAUSE	REMEDY	RECOMMENDATIONS
<ul style="list-style-type: none"> • BATTERY FAULTY • INCOMPLETE CIRCUIT • SHORT CIRCUIT IN WIRE SYSTEM • ERRONEOUS GAUGE READINGS • DAMAGED OR LOOSE ALTERNATOR BELT • DIRTY, LOOSE OR DAMAGED CONNECTIONS • FAULTY ALTERNATOR 	<ul style="list-style-type: none"> • CHECK/REPLACE • USE OF AMP METER IS NOT COMPATIBLE WITH ENGINE WIRING. SEEK QUALIFIED HELP • TEST/REPAIR • CHECK WITH MULTI-METER TYPE GAUGE • CHECK/CHANGE • CHECK ALL ELECTRICAL CONNECTIONS AND WIRES. CLEAN AND TIGHTEN. • TEST/REPLACE 	
<p>RECOMMENDATIONS:</p> <p>IT IS ALWAYS NECESSARY TO CHECK BASIC WIRE CONNECTIONS. DUE TO THE UNUSUAL AMOUNT OF VIBRATION, CONNECTIONS MAY BECOME LOOSE OR FAULTY.</p>		

EXTERIOR APPEARANCE FOULING		
CAUSE	REMEDY	RECOMMENDATIONS
<ul style="list-style-type: none"> • ENGINE GASKETS WEEPING • SEA WATER HOSE LEAKS AT HIGH RPM'S 	<ul style="list-style-type: none"> • CHECK/REPLACE/PAINT • CHECK 	

EXTERIOR APPEARANCE FOULING		
CAUSE	REMEDY	RECOMMENDATIONS
<ul style="list-style-type: none">• INADEQUATE VENTILATION IN ENGINE COMPARTMENT	<ul style="list-style-type: none">• CHECK/CORRECT	
RECOMMENDATIONS: MARINE ENGINES ARE SUBJECT TO EXTREME CONDITIONS AND ENVIRONMENTS. ROUTINE MAINTENANCE IS THE KEY TO ENGINE LONGEVITY. CHECKING THE BASIC ITEMS ON A PERIODIC BASIS WILL PREVENT UNNECESSARY PROBLEMS.		

ENGINE ELECTRICAL

SECTION 4

GENERAL INFORMATION.....	2
BATTERY.....	2
Selection.....	2
Battery Cables.....	2
Battery Testing.....	2
STARTER MOTOR.....	3
Starter Motor Tests.....	4
Identification.....	4
Starter Motor Specifications.....	4
Starter Motor Noises.....	5
REPLACEMENT OF STARTER MOTOR.....	5
SHIMMING STARTER MOTOR (ENPAC ENGINES).....	6
OILING STARTER PINION GEAR (SPORTPAC ENGINES).....	6
IGNITION.....	7
Ignition Coil.....	7
Electronic Module.....	7
Pole Piece and Coil Assembly.....	7
DISTRIBUTOR REMOVAL.....	8
DISTRIBUTOR INSTALLATION.....	8
ALTERNATOR.....	8
Alternator Troubleshooting Guideline.....	9
Removal.....	10
Installation.....	10
DRIVE BELT REPLACEMENT AND ADJUSTMENT.....	11
DIAGRAMS.....	12
Engine Wiring Harness Diagram - All Models With Prestolite Ignition / Mechanical Fuel Pump.....	12
Engine Wiring Harness Diagram - 181 (ENPAC),262,350 (Previous) - Mechanical Fuel Pump System.....	13
Engine Wiring Harness Diagram - 181 (ENPAC),262,350 (Current) - Mechanical Fuel Pump System.....	14
Engine Wiring Harness Diagram - 181 (SPORTPAC),250,262,454,502 (Previous) - Electric Fuel Pump System.....	15
Engine Wiring Harness Diagram - 181 (SPORTPAC),250,262,454,502 (Current) - Electric Fuel Pump System.....	16
Initial Timing Jumper Diagram (NON-MSTS).....	17
Shift Assist Wiring Diagram (NON-MSTS) - Mercruiser Applications.....	18
Parpac Wiring Diagram For Electric Fuel Pump - 181,250,262,454,502.....	19
Electric Fuel Pump and Water Separator Filter Locations - 262,454,502.....	20

GENERAL INFORMATION

Please observe the following warnings whenever working on a Marine Power Engine.

WARNING !

- **Always** disconnect the battery cables from battery, negative terminal first, **before** performing engine disassembly/reassembly procedures.
- Electrical and ignition components on your Marine Power engines are designed and manufactured to comply with U.S. Coast Guard Rules and Regulations to minimize risks of fire and explosion.
- Use of replacement electrical or ignition system components, which do not comply with these rules and regulations, could result in a fire or explosion hazard and should be avoided.
- When serving the electrical and ignition systems, it is extremely important that all components are properly installed and tightened. If they are not, any electrical or ignition component opening would permit sparks to ignite fuel vapors from possible fuel system leaks.
- To prevent the possibility of a **FIRE** or **EXPLOSION**, be sure that the engine compartment is well ventilated and that there are no gasoline vapors present.

BATTERY

IMPORTANT: When installing a battery, it is important that all standards and regulations (boating industry, Federal and Coast Guard) are adhered to. Battery cable installation must meet the pull test requirements and the positive battery terminal must be properly insulated in accordance with standards and regulations.

IMPORTANT: Engine electrical systems are negatively (-) grounded. In some states it is recommended that the battery be installed in an enclosed case. Please refer to the regulations for your area.

SELECTION

A battery should be selected that meets all of the following specifications:

1. 12-V Marine Type.
2. Tapered post connectors or side terminal connectors. Do not use batteries with wing-nut type connectors.
3. Reserve capacity must be *at least* 450 cold cranking amps.

BATTERY CABLES

1. To provide the proper electrical flow from the battery to the engine components, the battery cable must consist of the proper specifications, as detailed below:

<u>CABLE LENGTH (ft)</u>	<u>CABLE GAUGE (mm)</u>
Up to 3½	4
3½ - 6	2
6 - 7½	1
7½ - 9½	0
9½ - 12	00
12 - 15	000
15 - 19	0000

The above applies to both negative (-) and positive (+) cables.

2. Terminals must be soldered to cable ends to ensure proper electrical contact. It is recommended to use electrical-grade resin flux solder only as acid flux solder may cause corrosion and subsequent failure.
3. Check battery condition, including cables, connectors, etc., periodically.

BATTERY TESTING

Please read carefully and follow these warnings and precautions when conducting any battery tests.

1. Make sure battery is tested in a well ventilated area as batteries will give off hazardous explosive gases. Be sure that the bilge blower is in operation when battery is being charged.

BATTERY TESTING (Continued)

2. Do not smoke or allow open flames or spark sources in the area when charging the battery.
3. The battery acid, electrolyte, is very corrosive and should be handled with extreme caution. If the acid is splashed or spilled on any part of the body, wash the effected area immediately with liberal amounts of water and obtain medical assistance (if necessary) as soon as possible. When handling batteries, it is strongly recommended that rubber gloves and safety glasses be worn.
4. In an effort to prevent unnecessary damage to the electrical system, make sure the following procedures are adhered to:
 - When installing the battery, be sure to first connect the positive (+) battery cable to the positive (+) battery terminal, then connect the negative (-) battery cable to the grounded negative (-) terminal.
 - Never disconnect the battery cables when the engine is operating.
 - When using a charger or booster, be sure to connect it to the appropriate connections (positive to positive and negative to negative).
 - When applying a booster charge to the battery, disconnect both cables from the battery. This will prevent damage to the voltage regulator.
5. Before testing, certain conditions must be met. These conditions are, but not limited to:
 - The battery must be within a temperature range of 60°F (16°C) to 100°F (38°C). The battery should not be exposed to extreme temperatures outside of the desired range.
 - The acid/electrolyte level must be correct in all cells.
 - The battery must be *at least* half-charged.
 - The battery must have no obvious defects.
6. If the above conditions are met, the battery testing may be conducted following these procedures:
 - Place the engine under a heavy load by cranking engine (or with a variable resistor tester) and test battery voltage.
 - Compare the voltage obtained from this test to the battery manufacturer's specifications.
 - If the voltage readings are low, recharge the battery and retest.
 - If the voltage reading remains low, the battery should be replaced.

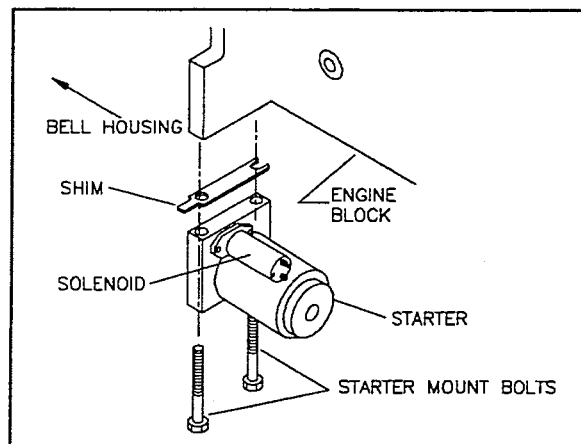
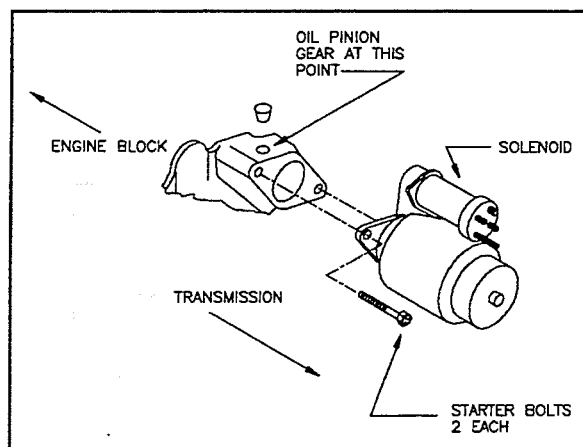
STARTER MOTOR**Bottom Mount Starter (Enpac Models)****Top Mount Starter (Sportpac Models)**

The starter motors used on Marine Power Engines are marine starters manufactured by DELCO-REMY. The starter is located in one of two locations on the engine depending upon the type of engine package used. On the ENPAC model engine, the starter is bottom mounted in a standard automotive configuration. On the SPORTPAC model engine, the starter is mounted on the top of the bellhousing, with the pinion gear end of the starter facing the engine (opposite of a standard automotive configuration). The only maintenance needed for these starters, short of correcting a malfunction, is the lubrication of the pinion gear in the top mount starter and the shimming of the bottom mount starter.

STARTER MOTOR TESTS

NOTICE: Never operate the starter motor more than 30 seconds at a time without pausing to allow it to cool for at least two minutes. Overheating, caused by too much cranking, will damage the starting motor.

Before replacing the starting motor, the following tests can be made.

Inspect:

- Pin on for freedom of operation by turning it on the spline shaft.
- Armature for freedom of rotation by prying the pinion with a screwdriver.
 - Tight bearings, a bent armature shaft, or a loose pole shoe screw will cause the armature to not turn freely.
 - If the armature does not turn freely, the motor should be rebuilt.

IDENTIFICATION

The starter identification number is located as shown.

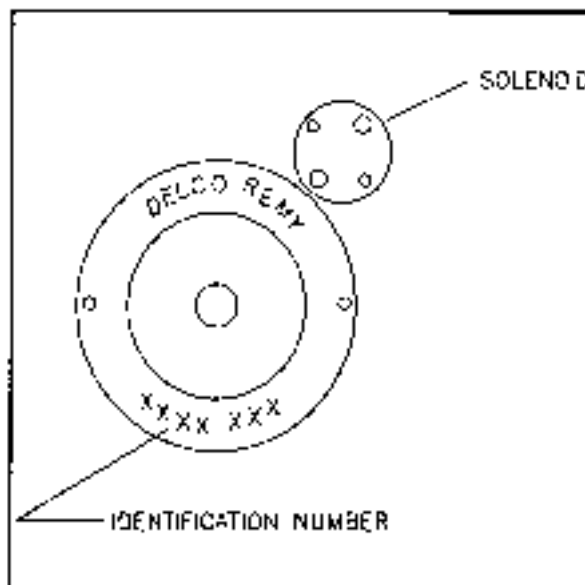

Starter Motor I.D. Number

STARTER MOTOR SPECIFICATIONS									
VENDOR ID #	MP #	MOUNT	ENGINE ROTATION	VOLTS	NO LOAD TEST				BRUSH SPRING TENSION oz. (N)
					MIN AMPS	MAX AMP	MIN RPM	MAX RPM	
1998318	0170-000	TM	LH	10.0	70	110	6500	10,700	56 -105 (15.57 -29.19)
1998570	0171-000	TM	RH						
1998599	0172-000	BM	LH						
1998317	0174-000	BM	LH						
STARTER BOLT TORQUE SPECIFICATIONS									
FASTENER LOCATION								lb-ft (N-m)	ft-lb (N-m)
STARTER MOTOR TO FLYWHEEL HOUSING								50 (68)	600 (68)
STARTER MOTOR TO BOTTOM OF BLOCK								35 (45)	
Pinion clearance				0.010 - 0.140 in. (0.254 - 3.56 mm)					
Commutator end-frame gap				0.025 in. max. (0.635 mm max.)					
LH = Left Hand (Normal) Engine Rotation					RH = Right Hand (Opposite) Engine Rotation				

STARTER MOTORS (Continued)

In the course of normal wear on the starter motor, certain noises may occur which need to be investigated. The following information will assist in locating and correcting starter noises as well as instruct how to remove, replace and shim starter motors.

STARTER MOTOR NOISES		
NOISE	CAUSE	REMEDY
<ul style="list-style-type: none"> • High pitch whine during cranking (engine starts and runs normally) • High pitch whine after engine fires and key is released • Loud "whoop" after engine fires but starter still engaged • A rumble, growl or knock as the starter comes to a stop after cranking the engine • A rapid clicking sound when key is in crank position • Starter makes loud hum (spins up to high rpm) when key is in crank position (does not crank engine) • Starter begins to turn engine but suddenly seizes 	<ul style="list-style-type: none"> • Excessive clearance between starter pinion gear and flywheel • Not enough clearance between starter pinion gear and flywheel • Defective starter motor clutch • Bent or unbalanced starter armature • Low battery charge or loose/corroded connections • Starter drive is broken • Engine may be hydro-locked 	<ul style="list-style-type: none"> • Remove shims at starter mount • Add shims at starter mount • Remove starter and have rebuilt • Remove starter and have rebuilt • Replace battery and/or clean terminals/connections • Remove starter and have rebuilt • Remove spark plugs and check for water in cylinders. Trace water leak before running engine (See "Cooling Systems" section)

**REPLACEMENT OF STARTER MOTOR
(SPORTPAC and ENPAC MODELS)**
Remove or Disconnect:

1. Battery negative cable.
2. Wiring from starter solenoid. *NOTE: Label wire for installation and support aft end of starter before proceeding. Supporting the starter will keep it from dropping and causing damage or injury.*
3. Starter mounting bolts from bellhousing.
4. Starter by pulling straight back and lifting away from engine (Sportpac) or straight back and lowering away from engine (Enpac). *NOTE: The starter is relatively heavy so make sure you have a secure grip before removal.*

5. Starter mount shims (Enpac engine only). *NOTE: Keep shims for starter installation.*

Clean or Inspect:

1. Wiring for corrosion or wear. Replace if necessary.
2. Starter pinion gear for chips, broken teeth, or unusual wear. Replace or have rebuilt if necessary.

Install or Connect:

1. Starter mount shims (Enpac engine only) if required.
2. Starter. *NOTE: The starter is relatively heavy so make sure you have a secure grip before installation.*
3. Starter mounting bolts to bellhousing.
4. Wiring to solenoid. *NOTE: Insure each contact is clean and the connections are tight.*
5. Battery negative cable.

SHIMMING STARTER MOTOR (ENPAC ENGINES ONLY)

If the starter motor makes a high pitched whine after the engine fires and the key is released, then the starter pinion gear has too tight of a fit when it meshes with the flywheel ring gear. The tight fit does not allow the starter pinion gear to retract away from the flywheel ring gear. The following procedure should be used to correct this problem.

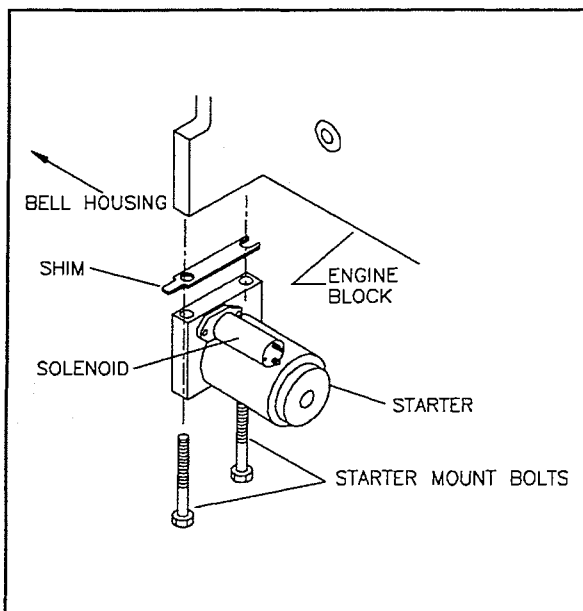

1. Disconnect battery negative cable.
2. Remove the outboard starter mount bolt.
3. Loosen, do not remove, the inboard starter mount bolt.
4. Add a 1mm shim by performing the following steps:
 - Grasp shim by the tab end and insert between the starter mount and engine block. Insure the open end of the shim slides around the inboard bolt.
 - Align the shim hole and the starter mount hole.
 - Insert the outboard mount bolt through the mount and shim holes and thread the bolt into the engine block.
5. Tighten mount bolts to 45 N•m (35 ft.lbs.).
6. Connect battery negative cable.

7. Crank engine, if noise still exists, then use one more shim between the starter mount and engine block. *NOTE: No more than two 1mm shims should be used in this procedure.*

OILING STARTER PINION GEAR (SPORTPAC ENGINES ONLY)

After every 100 hours of engine operation, it is recommended that the starter pinion gear be lubricated for longer life. The following procedure is recommended.

1. Disconnect the battery negative cable to keep engine from being cranked while performing maintenance.
2. Locate the rubber plug in the bellhousing immediately in front of the starter solenoid.
3. Remove the plug and pour 1-2 ounces of 30 weight oil into the hole and replace the plug.
4. Reconnect battery negative cable.

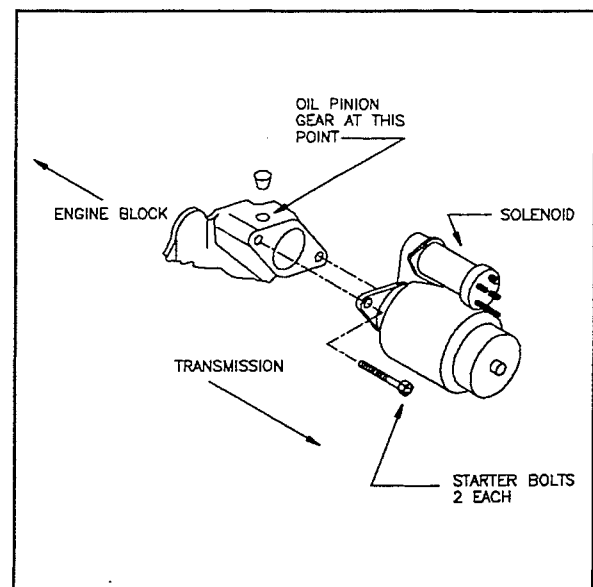

Top Mount Starter Lubrication

NOTE: In some Enpac repower applications, an oil hole may be available in the bellhousing. If so, the pinion gear may be oiled by pumping 1-2 ounces of 30 weight oil onto the gear with an oil can or gun.

IGNITION

Marine Power Engines use a Delco E.S.T. ignition system consisting of a distributor, ignition coil, wiring and spark plugs. The distributor consists of a module, pick-up coil and conventional cap and rotor.

DESCRIPTION

This distributor is a magnetic pulse triggered, transistor controlled, inductive discharge distributor. The magnetic pickup assembly located inside the distributor contains a permanent magnet, a pole piece with internal teeth, and a pickup coil. When the teeth of the timer core rotating inside the pole piece line up with teeth of the pole piece, an induced voltage in the pickup coil signals the electronic module to trigger the coil primary circuit. The primary current decreases and a high voltage of up to 35,000 volts is induced in the ignition coil secondary winding which is directed through the rotor and secondary leads to fire the spark plugs. The capacitor in the distributor is for radio noise suppression.

The magnetic pickup assembly is mounted over the main bearing of the distributor housing. The electronic module within the distributor automatically controls the dwell period.

This EST (Electronic Spark Timing) system may include MSTS (Microprocessor Spark Timing System). Refer to "MSTS", Section 5.

IGNITION COIL

The coil is built like a transformer with the winding surrounded by a laminated iron frame. It generates a high secondary voltage (up to 35,000 volts) when the primary circuit is broken. It may be contained in the cap or mounted separately and connected to the distributor by a high tension wire.

ELECTRONIC MODULE

The electronic module is a solid state unit containing many complex circuits. The circuits control spark triggering, switching, current limiting, dwell control and

distributor pickup. The dwell angle is controlled by the module and is varied in direct relation to engine speed.

With a MSTS system, the computer sends signals to the module to control dwell and spark timing. The module may have from four to eight terminals, depending on the ignition system.

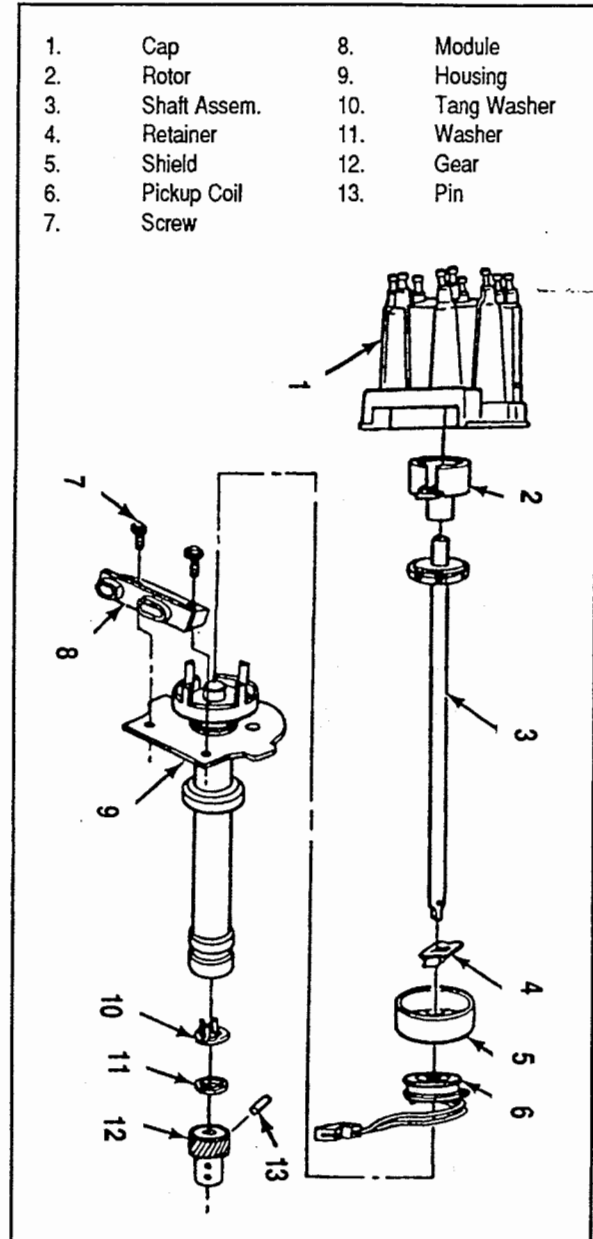

*Distributor with Separate Coil
and Sealed Connectors*

POLE PIECE AND COIL ASSEMBLY

The pole piece and plate assembly (often referred to as the pickup coil assembly) consists of the following: A stationary pole piece with internal teeth and a pickup coil and magnet which are located between the pole piece and a bottom plate.

DISTRIBUTOR REMOVAL

1. Remove distributor cap (2 screws). Do not remove plug wires from cap unless necessary.
2. Disconnect distributor primary leads at coil.
3. Crank or turn engine slowly. Align timing marks when rotor is pointing to No. 1 terminal of distributor cap. If same distributor is to be reinstalled in engine, mark position of distributor housing in relation to engine so that distributor may be installed in same position.
4. Remove distributor retaining clamp.
5. Remove distributor.

NOTE: To simplify distributor installation, do not turn crankshaft with distributor removed from engine.

DISTRIBUTOR INSTALLATION

ENGINE NOT DISTURBED:

1. Install distributor shaft into engine, aligning marks made at time of removal. Be sure that shaft engages oil pump.
2. Install clamp.
3. Install distributor cap.

IMPORTANT! Set engine timing with timing light. See Timing procedure in Owner's Manual.

ENGINE DISTURBED:

1. Rotate engine (in normal direction of rotation) until timing mark on torsional damper (or flywheel) lines up with TDC on timing tab and engine is in No. 1

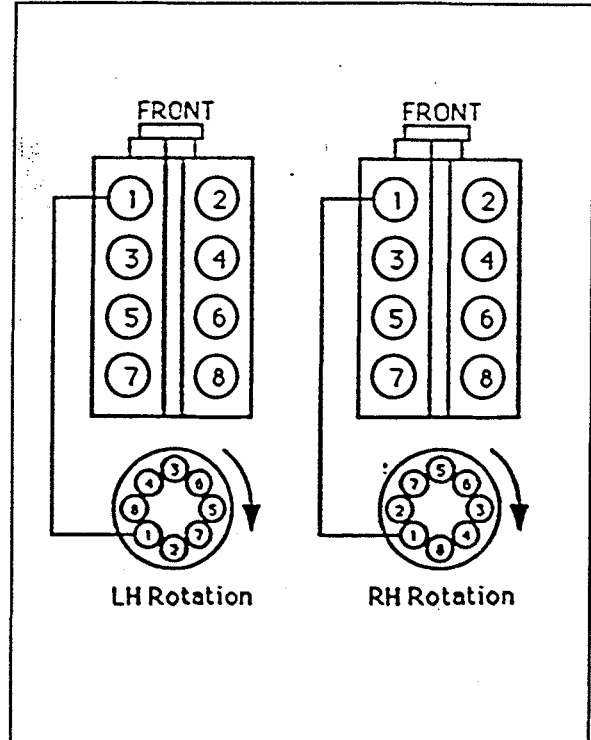

Spark Plug and Distributor Order

firing position.

2. Install distributor into engine so that the rotor is aligned with No. 1 spark plug tower on distributor cap.
3. Secure distributor with clamp.
4. Install distributor cap.

IMPORTANT! Set engine timing with timing light. See Timing procedure in Owner's Manual.

ALTERNATORS

DESCRIPTION

The alternator currently used on Marine Power Engines is a Mando brand alternator rated at a 51 amp output. It is cooled by a fan attached to the pulley as is typical with most alternators.

ALTERNATORS (Continued)

An alternator generates power by using the rotational force of the alternator driven pulley to turn the rotor inside the stationary component of the alternator called the stator. The rotor produces a magnetic field which, when turned inside the stator, induces an electrical current in the stator windings of the alternator. This current is routed to the regulator which converts the current from alternating current (AC) to direct current (DC). This current is then routed to the battery, if needed.

When examining the charging system and the alternator is suspected of being defective, the following precautions should be noted before attempting to remove or service the alternator:

1. Do not ground the alternator output terminal while engine is running.
2. Do not ground the field circuit between the alternator and regulator as this will damage the regulator.

3. When connecting the battery, do not reverse connect the cables, this will destroy the circuit diodes.

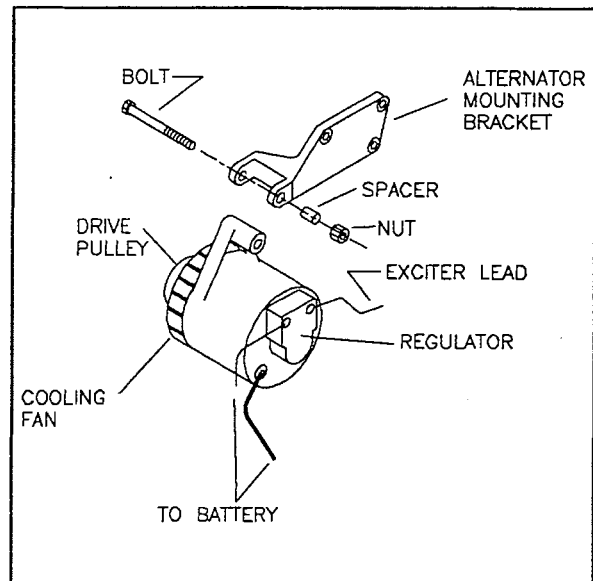

Marine Power Alternator

ALTERNATOR TROUBLESHOOTING GUIDELINE

The following problems and their respective causes will assist in rectifying the defective component(s).

LOW ALTERNATOR OUTPUT or LOW BATTERY CHARGE	
CAUSE	REMEDY
<ul style="list-style-type: none"> • Loose or slipping alternator drive belt • Current encountering high resistance in charging circuit • Rectifier shorted or an open exists • Stator windings are shorted to ground 	<ul style="list-style-type: none"> • Tighten drive belt • Check resistance in wire connected to battery from alternator • Replace alternator or have alternator rebuilt • Replace alternator or have alternator rebuilt

OVERCHARGED BATTERY (EXCESSIVELY HIGH ALTERNATOR OUTPUT)	
CAUSE	REMEDY
<ul style="list-style-type: none"> • Defective regulator • Improper ground between regulator and alternator case • Faulty ignition switch 	<ul style="list-style-type: none"> • Remove alternator and have checked or rebuilt • Remove regulator and clean contact surface and reconnect • Replace switch

UNSTEADY ALTERNATOR CHARGE	
CAUSE	REMEDY
<ul style="list-style-type: none"> • Loose or broken alternator drive belt • Discharged or defective battery • Defective regulator • Corrosion of the battery connections • Current encountering high resistance in the charging circuit • Open stator winding • Body-to-ground lead not connected properly 	<ul style="list-style-type: none"> • Tighten or replace belt • Fully recharge battery or replace • Have alternator checked and/or rebuilt • Remove and clean or replace cable connectors and clean battery posts • Check resistance in wire connected to battery from alternator • Replace alternator or have alternator rebuilt • Reconnect or clean connections and tighten

ALTERNATOR DOES NOT CHARGE	
CAUSE	REMEDY
<ul style="list-style-type: none"> • Loose or broken drive belt • Wiring or connections loose or corroded in charging circuit • Worn or sticking brushes or slip rings • An open in the rotor (field) circuit • Current encountering high resistance in charging circuit 	<ul style="list-style-type: none"> • Tighten or replace drive belt • Check all wiring, clean connections and tighten • Remove alternator and have rebuilt • Remove alternator and have rebuilt • Check resistance in wire connected to battery from alternator

ALTERNATOR CHATTERS or EMITS EXCESSIVE NOISE	
CAUSE	REMEDY
<ul style="list-style-type: none"> • Drive belt damaged or loose • Loose alternator mounting bracket • Alternator bearings worn out of tolerance • Rotor fan and alternator housing making contact • Defective rectifier • Defective stator winding 	<ul style="list-style-type: none"> • Replace or tighten drive belt • Tighten all mounting bracket bolts • Remove alternator and have it repaired/rebuilt • Remove alternator and have it repaired/rebuilt • Remove alternator and have it repaired/rebuilt • Remove alternator and have it repaired/rebuilt

REMOVAL

1. Disconnect battery cables from battery.
2. Disconnect wiring harness from alternator.
3. Loosen bolt attaching alternator to alternator mounting bracket.
4. Remove bolt attaching lower alternator brace to alternator.
5. Remove alternator mounting bolt, washers, spacer and nut. Carefully remove alternator.

INSTALLATION

1. Position alternator in mounting bracket and install bolt, washers, spacer and nut. Place washers on each side of spacer. *Do not* tighten securely at this time.
2. Fasten alternator brace to alternator with bolt, washers and spacer. *Do not* tighten at this time.
3. Position alternator drive belt on pulleys and adjust tension as per specifications (see page 4-11).
4. Tighten all fasteners securely.
5. Reconnect wiring to alternator and battery cables to battery.

**DRIVE BELT REPLACEMENT
AND ADJUSTMENT**

IMPORTANT: When adjusting drive belt tension, **DO NOT** apply pressure to alternator rear end frame, as alternator may be damaged.

1. To check belt tension, depress belt with thumb at midway point. The belt should depress $\frac{1}{4}$ " (6.35mm).
2. If adjustment or replacement is necessary, loosen alternator brace attaching bolts and alternator mounting bolt.
3. Pivot alternator inward to replace drive belt.
4. To obtain the correct belt tension, pivot alternator outward applying pressure to alternator front end frame only. Set the new belts at high reading.
5. Retighten alternator brace and mounting bolts securely.
6. Recheck the drive belt tension (step #1).

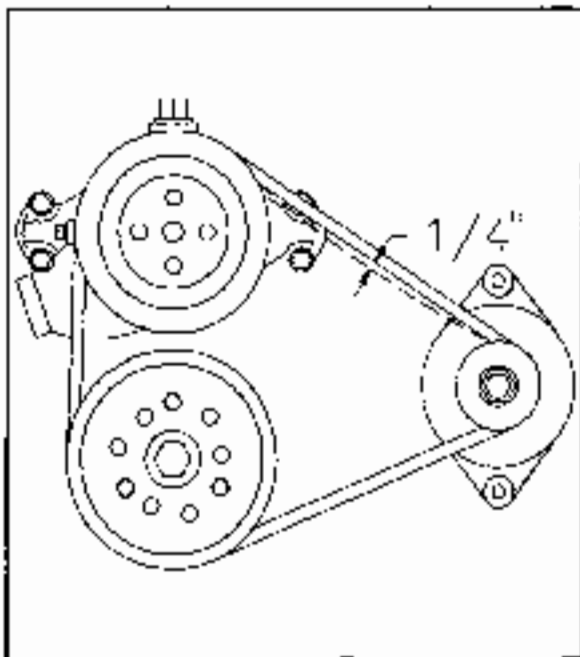

Drive Belt Replacement/Adjustment

ENGINE WIRING HARNESS DIAGRAM - All Models With Prestolite Ignition / Mechanical Fuel Pump System

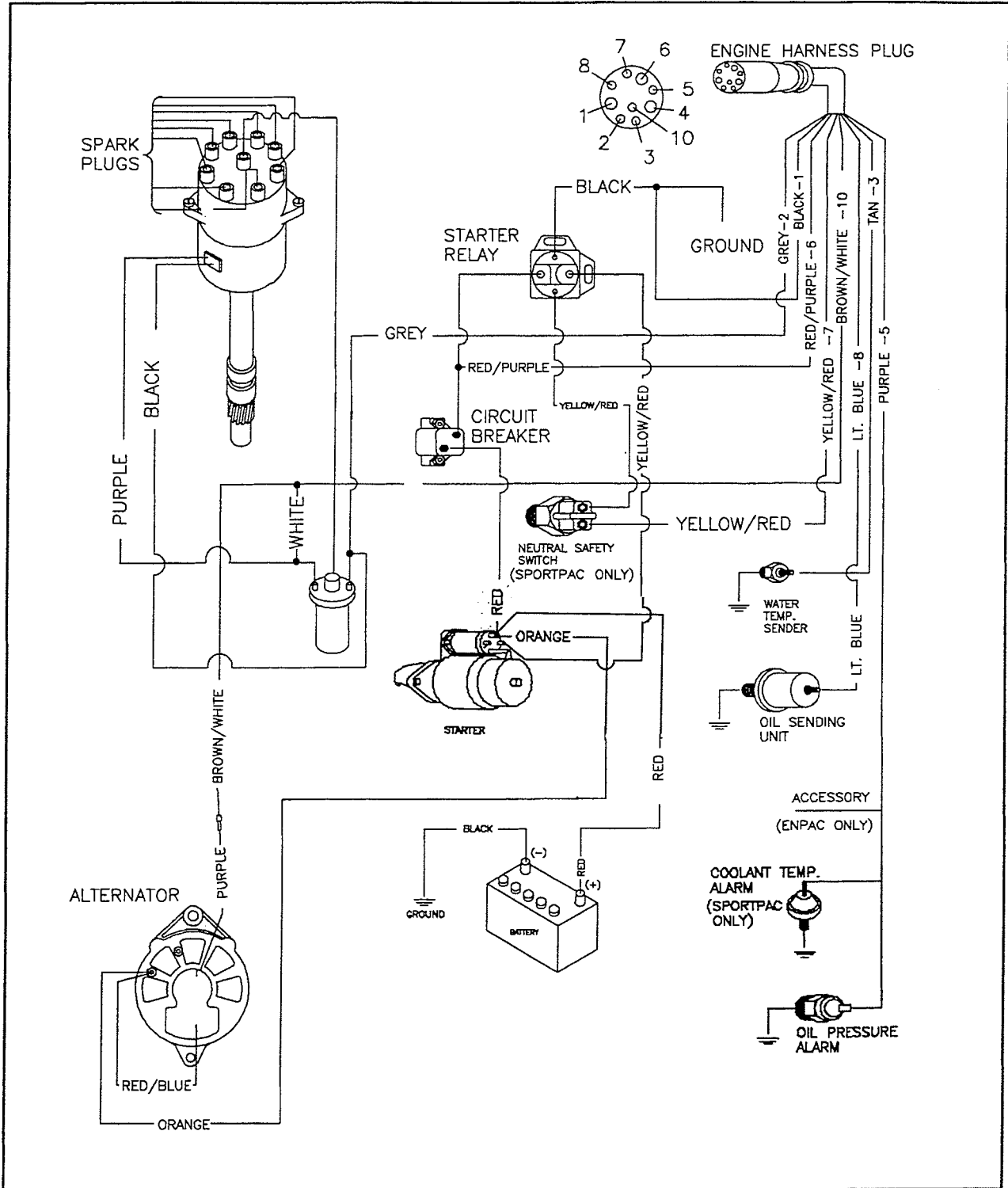

ENGINE WIRING HARNESS DIAGRAM - 181 (ENPAC) 262,350 (Previous)*

Mechanical Fuel Pump System

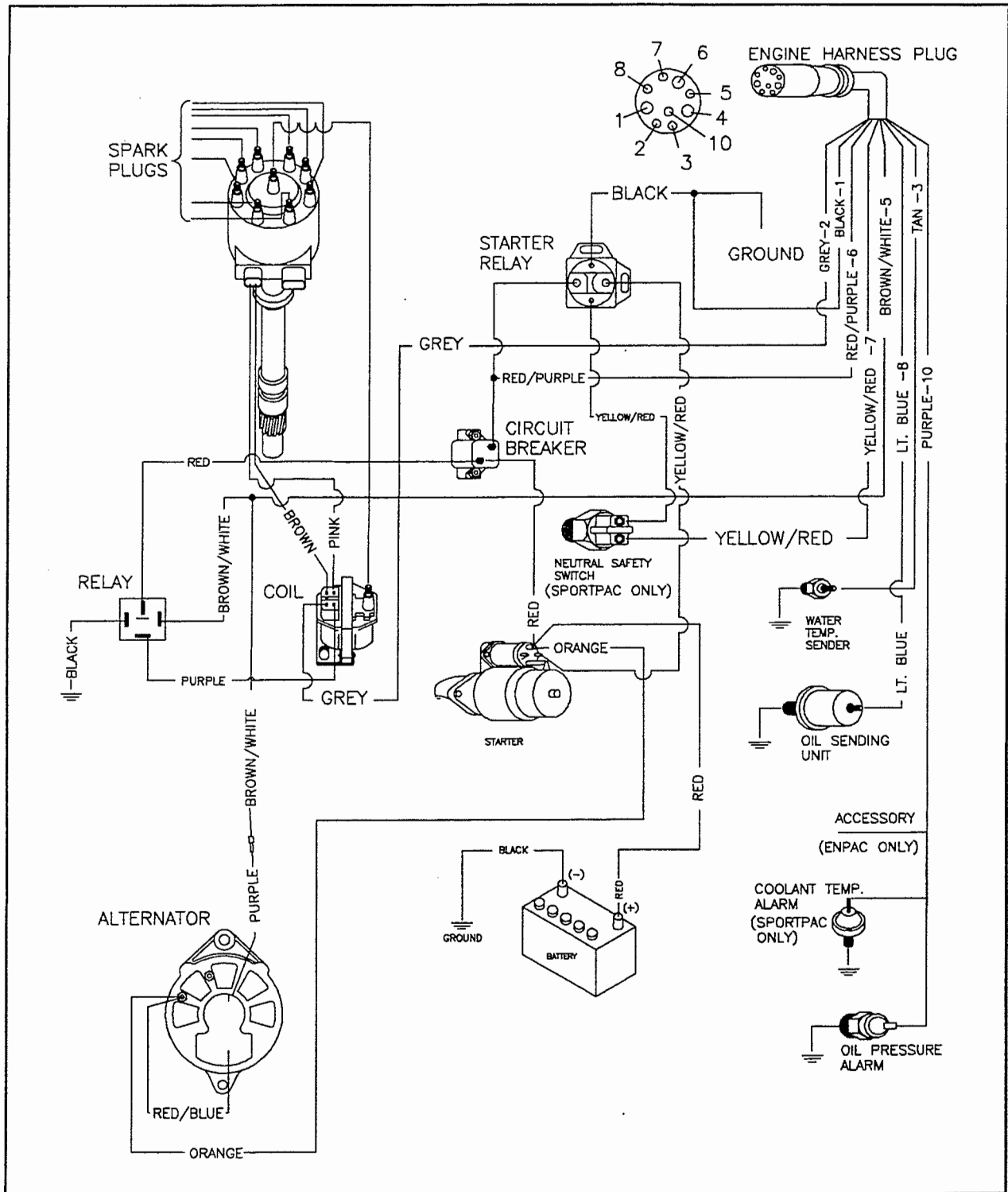

* This diagram applies to engines built with Delco Ignition Systems prior to July, 1992

ENGINE WIRING HARNESS DIAGRAM - 181 (ENPAC),262,350 (Current)* **Mechanical Fuel Pump System**

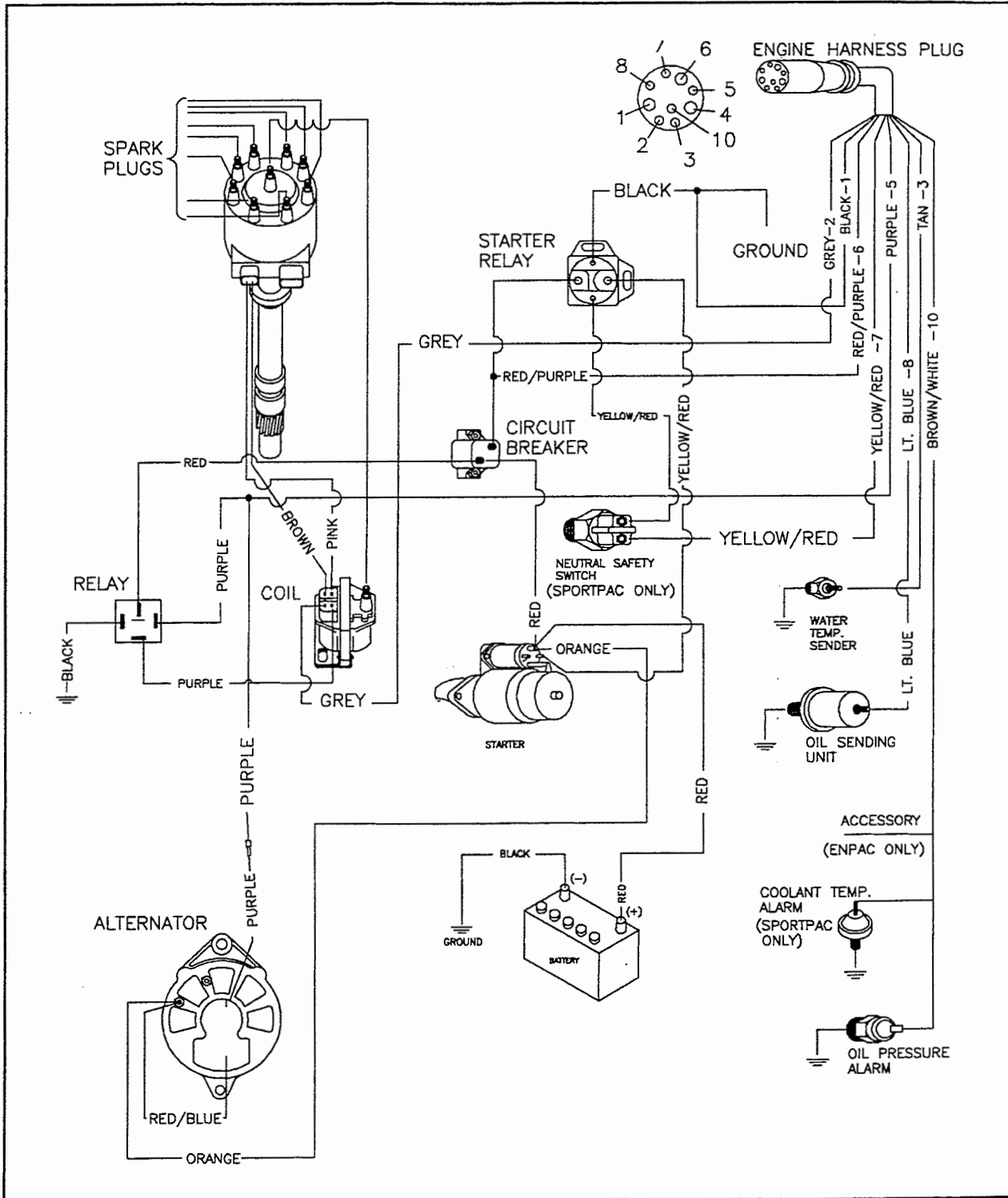

* This diagram applies to engines built with Delco Ignition Systems July, 1992 & after

ENGINE WIRING HARNESS DIAGRAM - 1B1 (SPORTPAC), 250,262,454,502 (Previous)* Electric Fuel Pump System

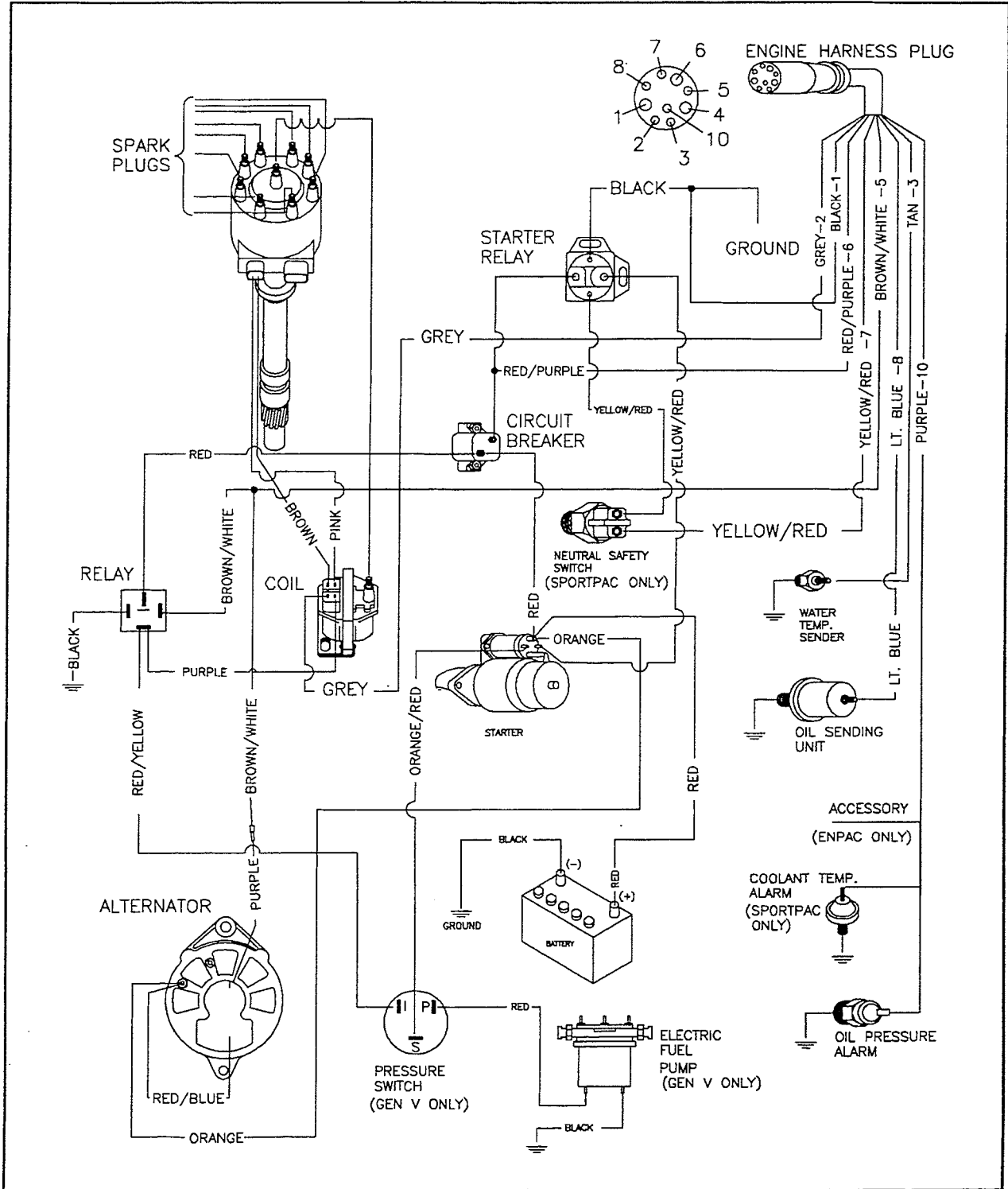

* This diagram applies to engines built with Delco Ignition Systems prior to July, 1992

ENGINE WIRING HARNESS DIAGRAM - 181 (SPORTPAC), 250, 262, 454, 502 (Current)* Electric Fuel Pump System

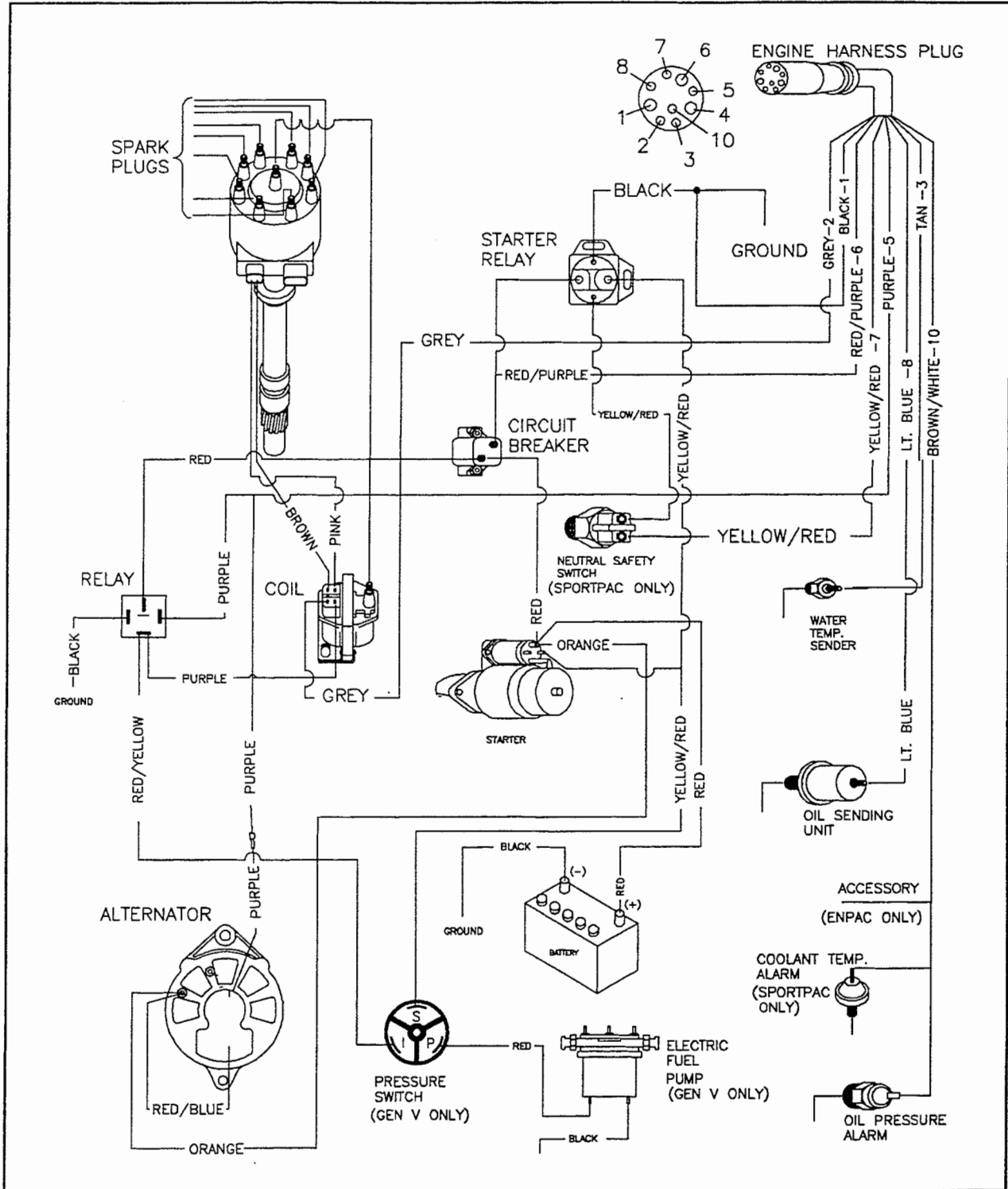

* This diagram applies to engines built with Delco Ignition Systems July, 1992 & after

INITIAL TIMING JUMPER DIAGRAM (NON-MSTS)

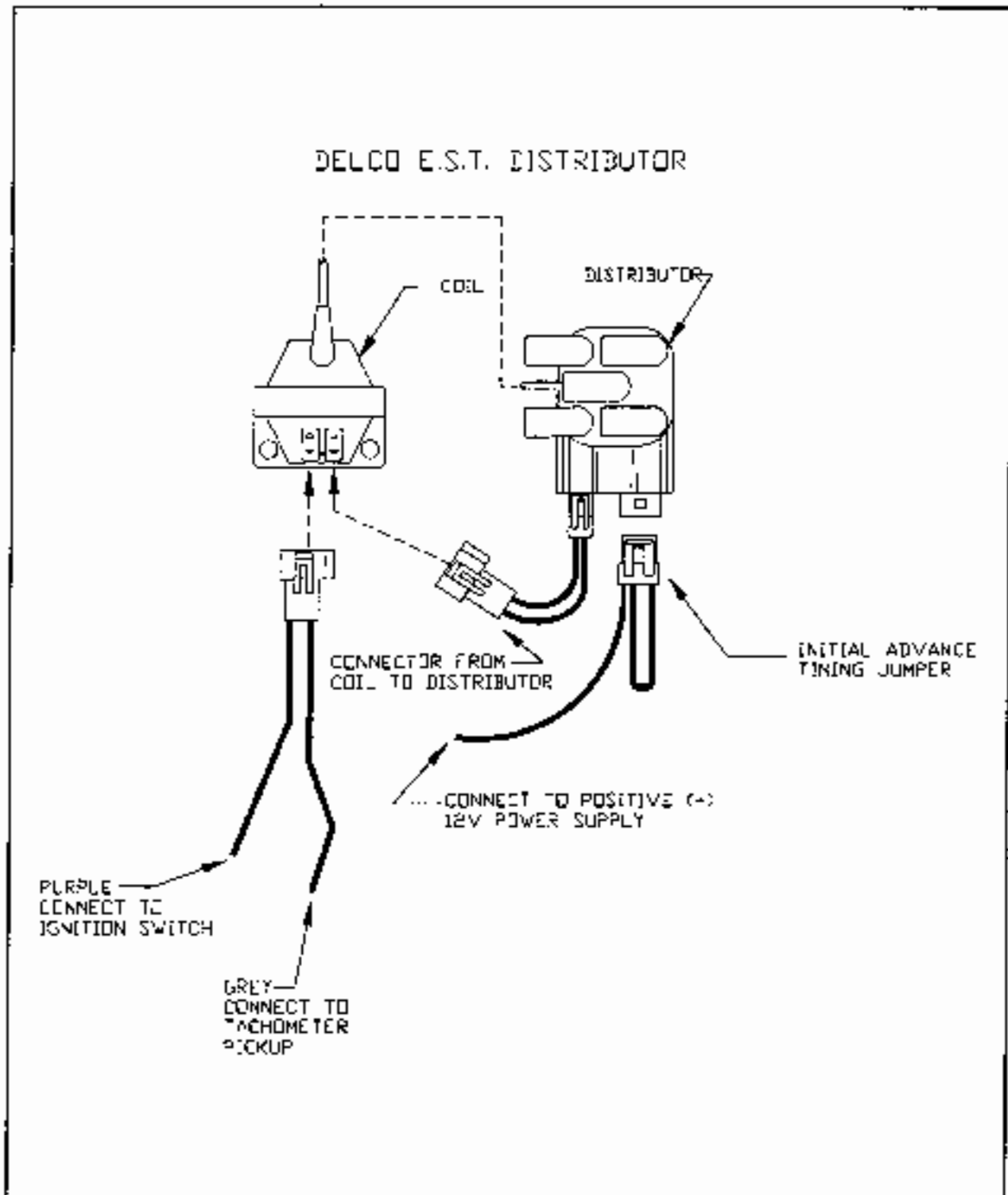

SHIFT ASSIST WIRING DIAGRAM (NON-MSTS) MerCruiser Applications

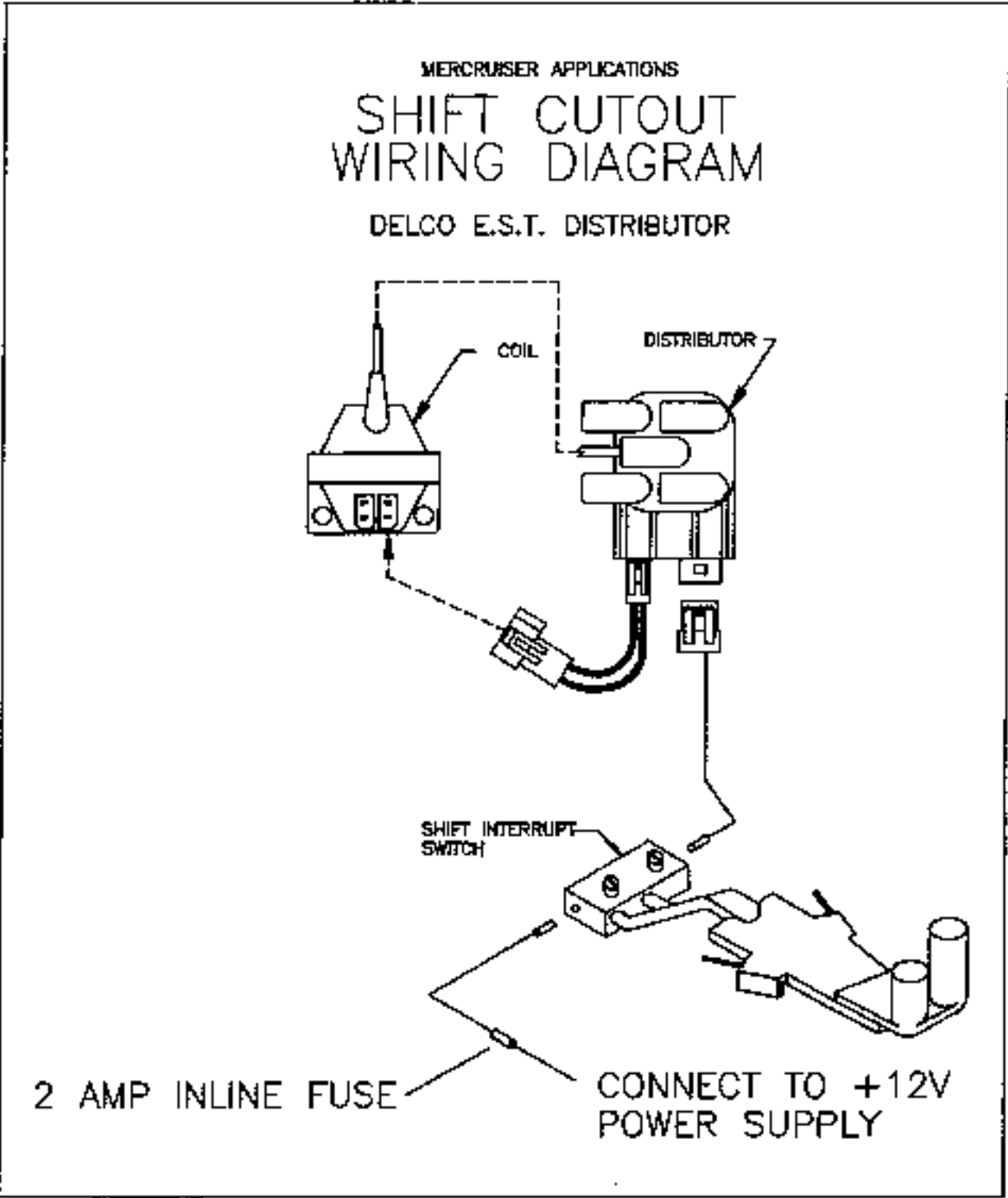

PARFAC WIRING DIAGRAM FOR ELECTRIC FUEL PUMP 181 250 262 454 502

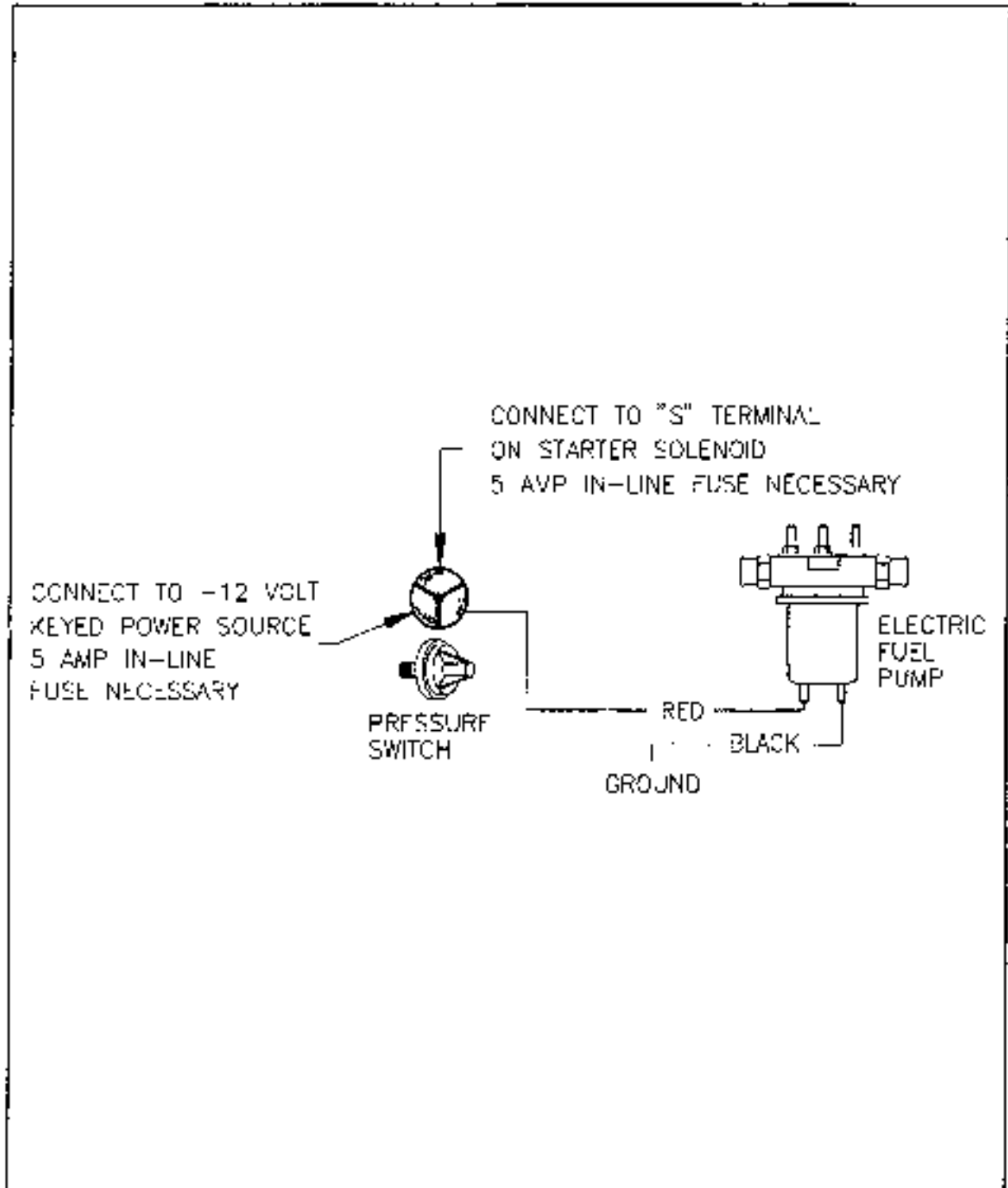

ELECTRIC FUEL PUMP AND WATER SEPARATOR FILTER LOCATIONS - 262,454,502

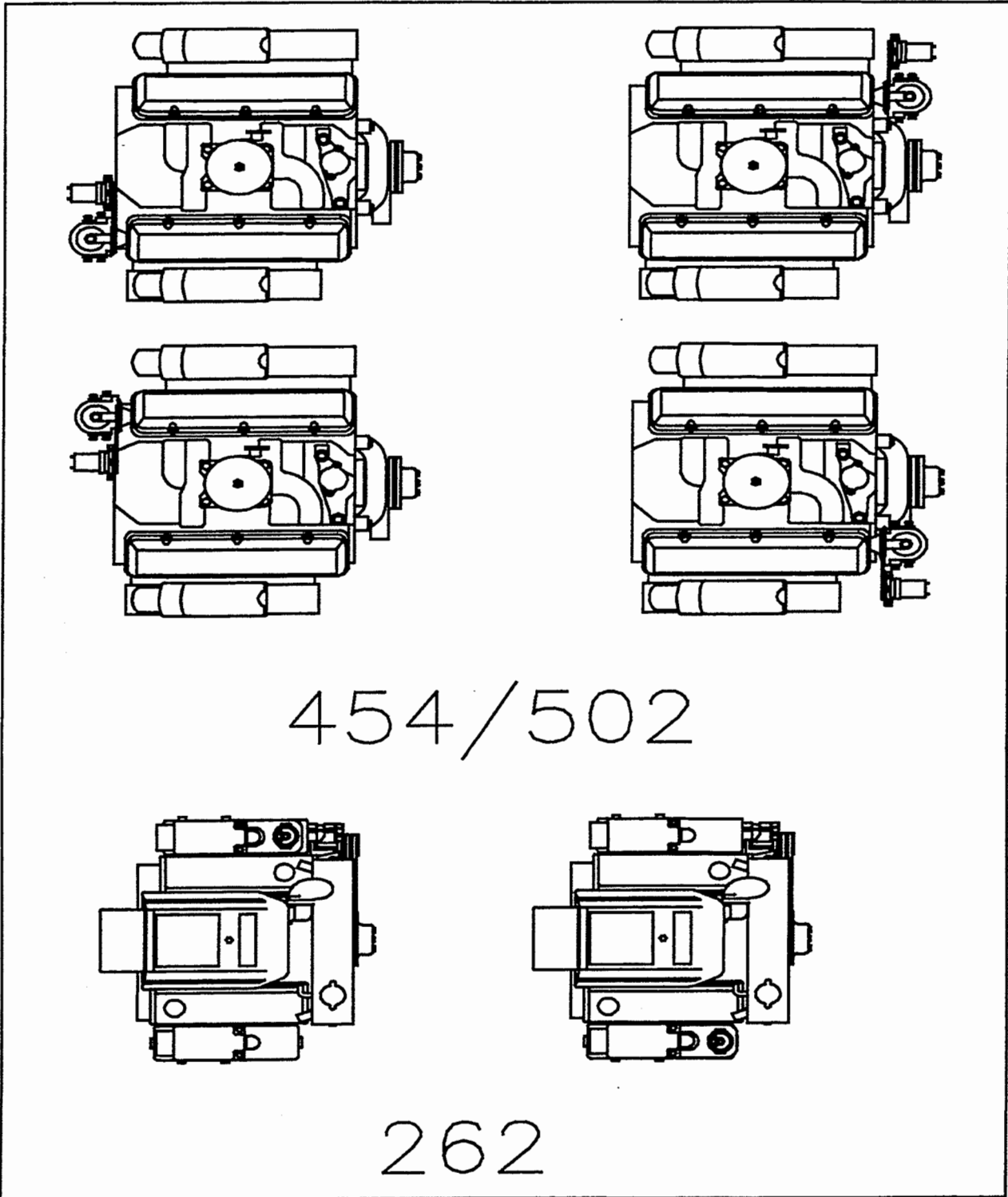

MSTS

SECTION 5

INTRODUCTION.....	2
ENGINE WIRING HARNESS DIAGRAM, 350-502 CID (5.7L-8.2L).....	3
WIRING DIAGRAM, 350-502 CID (5.7L-8.2L).....	4
ECM DIAGRAM.....	5
SHIFT ASSIST WIRING DIAGRAM.....	6
MSTS TIMING JUMPER.....	7
IGNITION TIMING PROCEDURES.....	9
MSTS SYMPTOM DIAGNOSIS AND DIAGNOSTIC CHARTS.....	10
Preliminary Checks.....	10
Intermittents.....	10
Hard Starting.....	10
Surges.....	11
Lack of Power.....	11
Detonation/Spark Knock.....	11
Hesitation.....	11
Cuts Out, Misses.....	12
Stalling, Rough, Unstable or Incorrect Idle.....	12
Dieseling, Run-on.....	12
Poor Fuel Economy.....	13
MSTS SYSTEM DIAGNOSIS.....	14
CONNECTOR IDENTIFICATION CHART.....	15
MSTS DIAGNOSTIC CHECK/CHART.....	16
MSTS SYSTEM RELAY CHECK/CHART.....	18
MSTS SYSTEM RELAY CHECK DIAGNOSTIC CHART.....	19
IGNITION SYSTEM CHECK/CHART.....	20
ELECTRONIC SPARK TIMING (EST) DIAGNOSTIC CHART (PART 1).....	22
ELECTRONIC SPARK TIMING (EST) DIAGNOSTIC CHART (PART 2).....	24
ELECTRONIC SPARK CONTROL (EST) DIAGNOSTIC CHART.....	26
MANIFOLD ABSOLUTE PRESSURE (MAP) SENSOR DIAGNOSIS CHART.....	28
MANIFOLD ABSOLUTE PRESSURE (MAP) OUTPUT CHECK.....	30
MANIFOLD ABSOLUTE PRESSURE (MAP) VOLTAGE/ALTITUDE COMPARISON CHART.....	32

INTRODUCTION

Increased demands for improved engine performance, economy and protection, along with advances in micro-electronic technology, have prompted the evolution of a new system which monitors and controls aspects of engine operation. The MSTS (Microprocessor Spark Timing System) was created with both the demands of the consumer and the environment in mind. The consumer wants an engine that performs consistently without dependence upon the operational conditions. Environmental concerns mandate that emission standards be observed. Both considerations are served by MSTS.

The MSTS is the second of a three part effort to manage engine operation via a microprocessor based system. High Energy Ignition (HEI) systems initially provided a more consistently delivered high voltage level to the spark plugs. MSTS incorporates HEI but adds the dimension of controlled timing, along with high temperature, detonation and high rev protection. The future is to incorporate electronic fuel injection (EFI) into the system, thus bringing about a climax to engine management. Fortunately, this system is not new. Since the early 1980's, microprocessor based monitoring and control systems have been standard equipment on most automobiles.

Previously, spark management was accomplished via a mechanical system (i.e., points) which became less efficient once the engine reached 1000 RPM's. The MSTS provides consistent performance to RPM's in excess of 3000. Improved efficiency in the ignition system lends itself to improved fuel economy, (while the monitoring system aids in engine protection).

The mechanical system was far less than ideal when it came to adjusting the spark timing while the engine was operating. The MSTS determines exactly when the best time is for the spark plugs to fire. In order to make this decision, the MSTS considers the engine's RPM's, coolant temperature, pressure, fuel, load, vibration and the charging rate of the ignition coil. Based on this criteria and the technology available, the system provides optimum ignition conditions. Like any mechanical system, the MSTS can malfunction. However, should the situation arise, the system can be easily disabled by disconnecting the four terminal connector at the base of the distributor and the engine will operate.

Engine RPM data is sent to the ECM via a magnetic pick-up coil in the distributor. For every revolution of the distributor shaft, eight voltage pulses are generated. By observing the time between each pulse, the ECM can calculate the engine RPM's.

Along with engine RPM's, the MSTS relies upon data from the Manifold Absolute Pressure (MAP) sensor to determine ignition timing. Manifold vacuum is the system's measure of engine load. Therefore, for a given load and speed combination, an optimum advance is delivered.

The Coolant Temperature Sensor (CTS) and the Knock Sensor serve mainly as engine protection devices. Some advance is added when the engine is cold; but, should the engine overheat, data from the CTS is used to retard engine timing. The knock sensor monitors engine noise frequency. Should the frequency associated with detonation be detected, ignition timing will be retarded.

Also, "Rev" limitation is accomplished through the ECM by retarding the timing once a designated limiting RPM is reached.

At Marine Power, we feel the future is now and that the MSTS affords the opportunity to ensure the boat owner is running an engine that is set up and performing to optimum specifications. It is our goal to provide the best system available to meet the demand.

MSTS ENGINE WIRING HARNESS DIAGRAM, 350 - 502 CID (5.7L-8.2L)

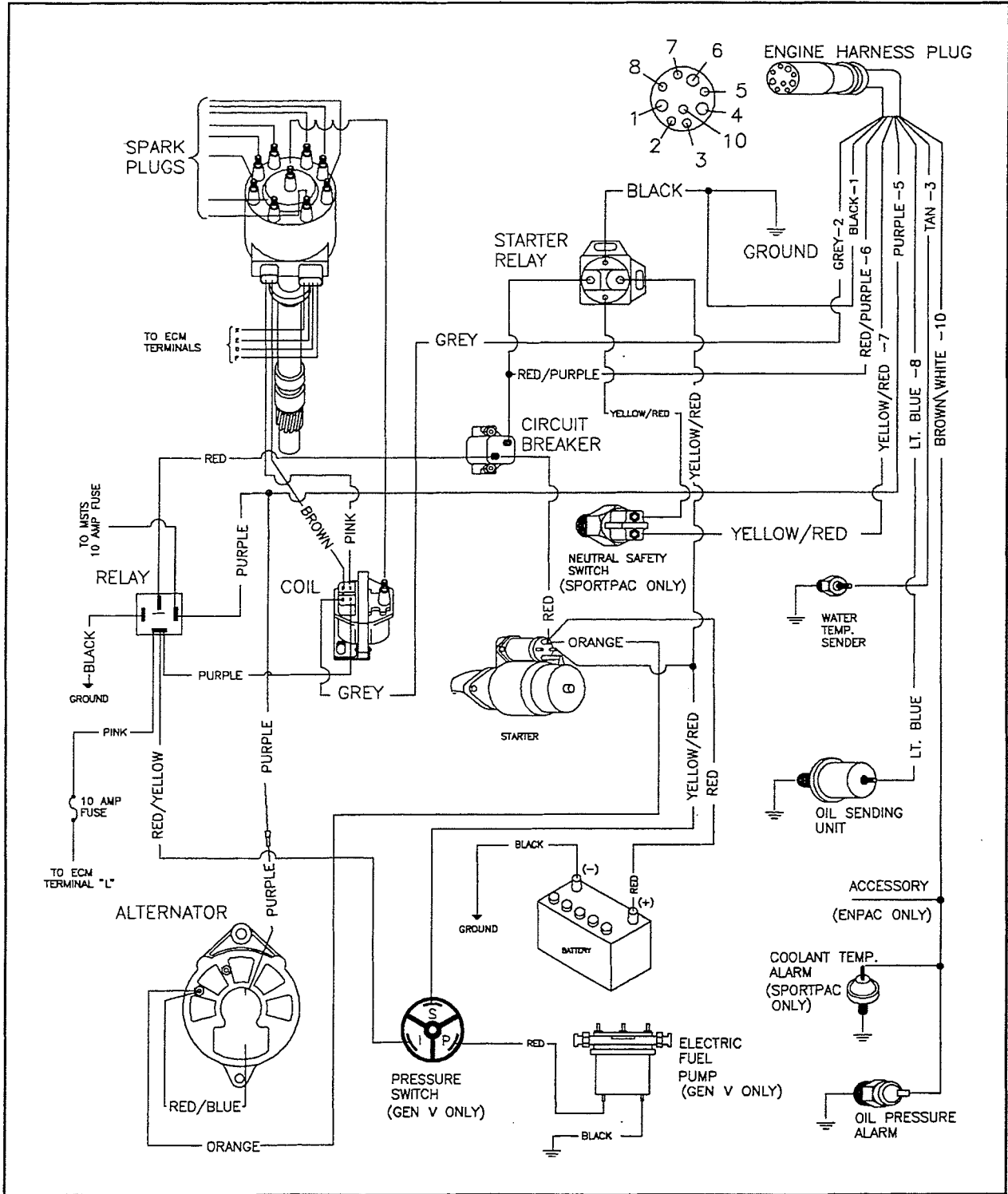

MST5 ECM DIAGRAM

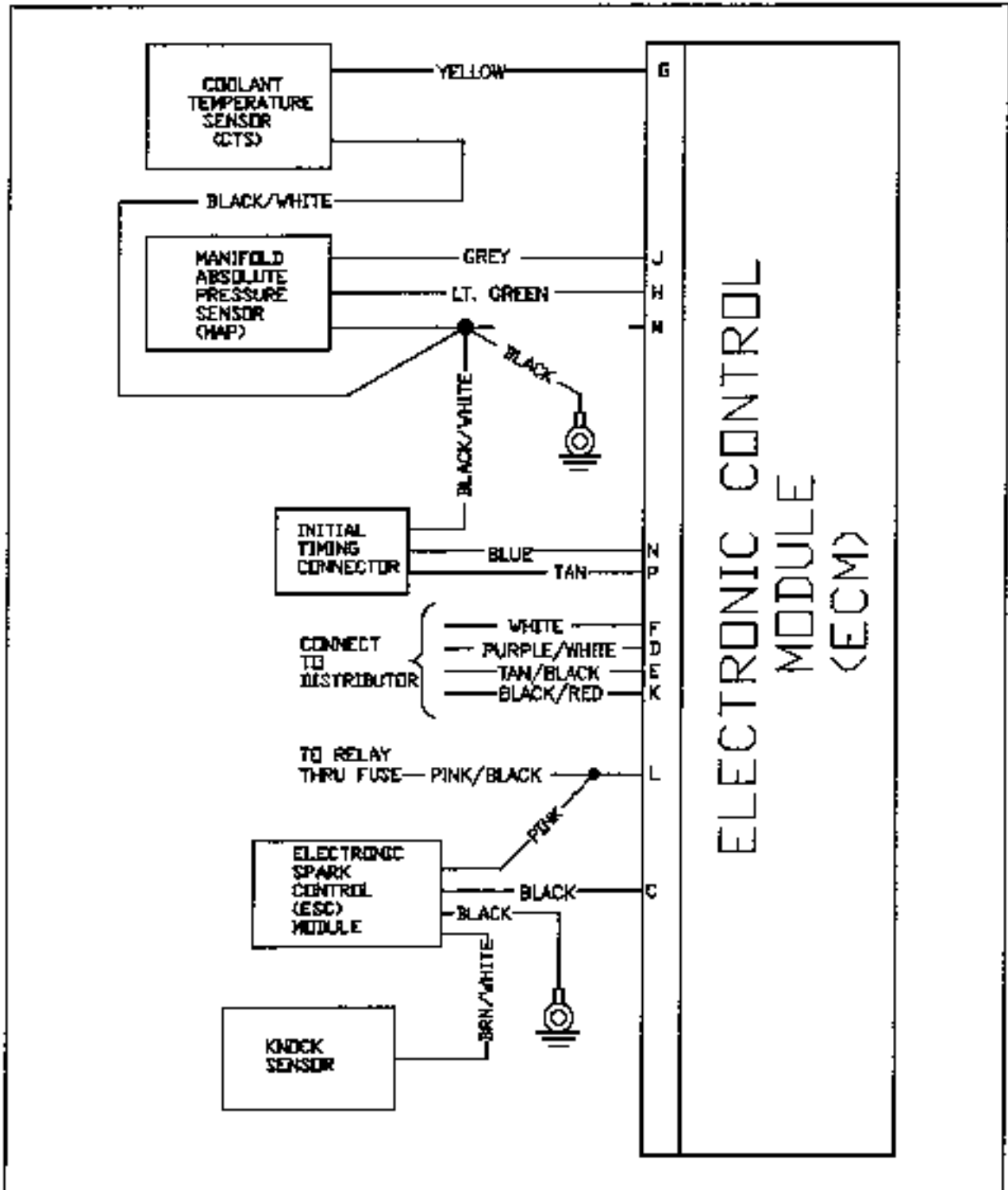

MSTS SHIFT ASSIST WIRING DIAGRAM MerCruiser Application

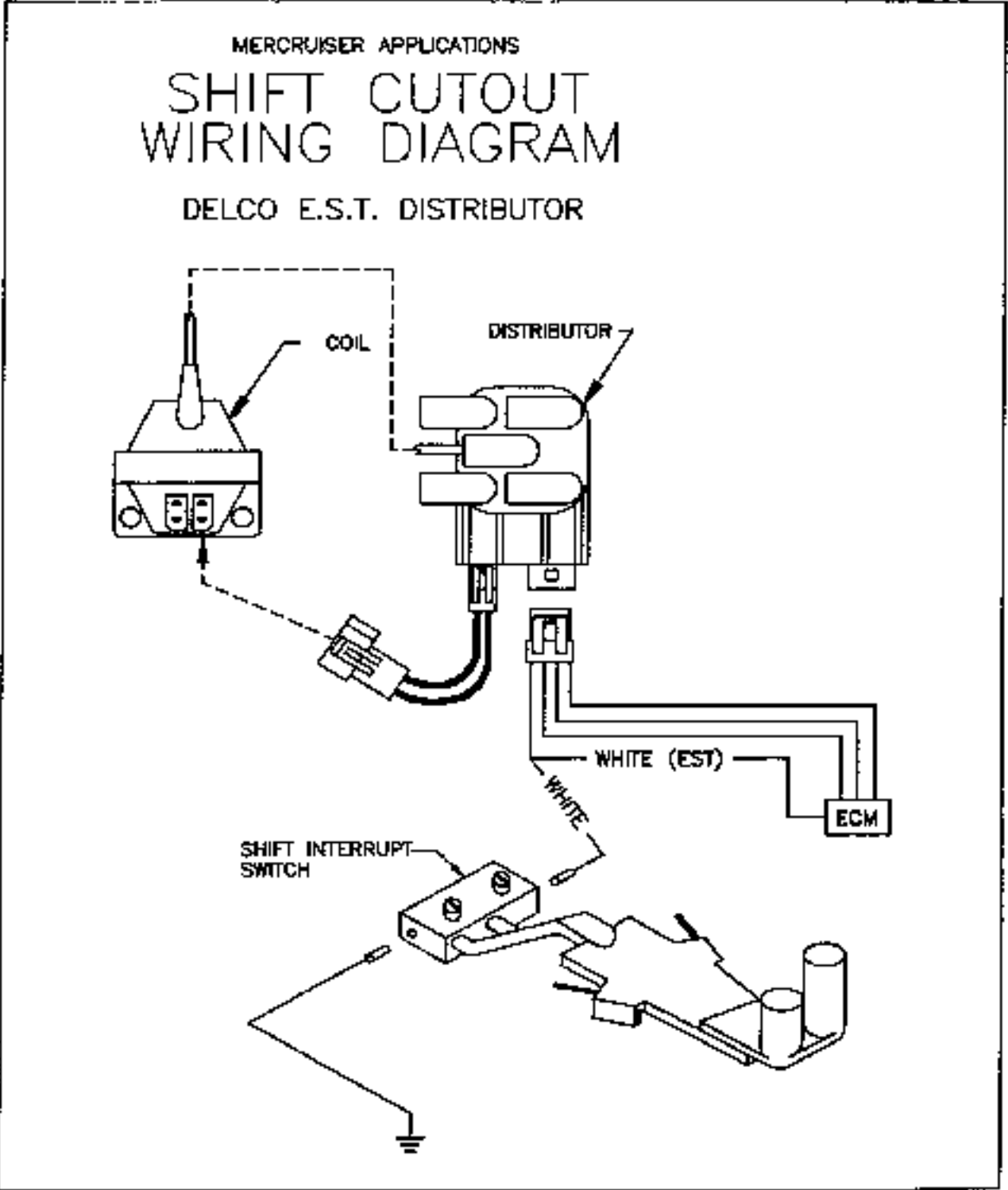

MSTS INITIAL TIMING JUMPER WIRING DIAGRAM

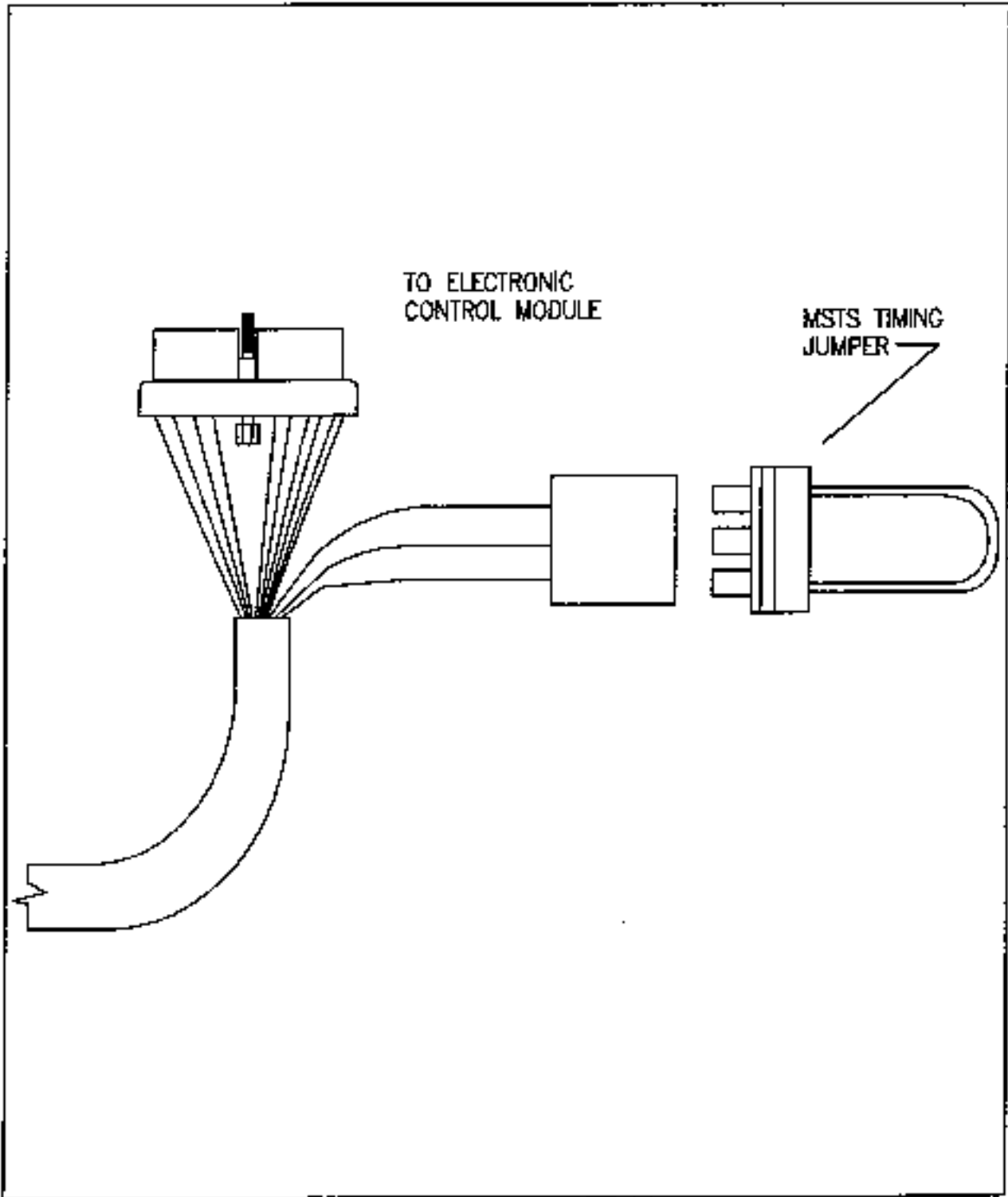

**THIS PAGE
LEFT BLANK
INTENTIONALLY**

CAUTION!

To reduce the chance of personal injury and/or property damage, the following instructions must be carefully observed.

Proper service and repair are important to the safety of the service technician and the safe, reliable operation of all Microprocessor Spark Timing System (MSTS) equipped engines. If part replacement is necessary, the part must be replaced with one of the same part number or with an equivalent part. **DO NOT USE A REPLACEMENT PART OF LESSER QUALITY.**

The service procedures recommended and described in this service manual are effective methods of performing service and repair. Some of these procedures require the use of tools specially designed for this purpose.

Accordingly, anyone who intends to use a replacement part, service procedure or tool, which is not recommended by the system manufacturer, must first determine that neither his safety nor the safe operation of the engine will be jeopardized by the replacement part, service procedure or tool selected.

It is important to note that this manual contains serious "CAUTIONS" and "NOTICES" that must be carefully observed in order to reduce the risk of personal injury during service or repair, or the possibility that improper service or repair may damage the engine or render it unsafe. It is also important to understand that these "CAUTIONS" or "NOTICES" are not exhaustive, because it is impossible to warn of all the possible hazardous consequences that might result from failure to follow these instructions.

MSTS IGNITION TIMING PROCEDURES**USING INITIAL TIMING CONNECTOR**

The MSTS initial timing connector is used to set the initial engine timing on MARINE POWER ENGINES equipped with MSTS. This connector by-passes the electronic spark timing of the engine and allows the initial timing to be adjusted by rotating the distributor. Become familiar with the entire procedure below before beginning.

The ignition timing marks are located on the engine's front cover. A saw slot on the harmonic balancer indicates engine at (TDC) Top Dead Center. Adjust ignition timing as follows:

1. Connect a timing light to the number one (1) spark plug wire. Connect the timing light power lead to a 12 volt power source. **DO NOT CONNECT TO 12 VOLTS ON ALTERNATOR.**
2. Start engine and allow to warm to operating temperature. Bring engine to idle (700 RPM).
3. **WHILE ENGINE IS RUNNING**, unplug initial timing connector at MSTS harness (Pages 5-7).
4. Loosen distributor clamp just enough to rotate distributor in place.
5. Attach timing light according to the manufacturer's instructions.

6. Rotate distributor to set mechanical timing.

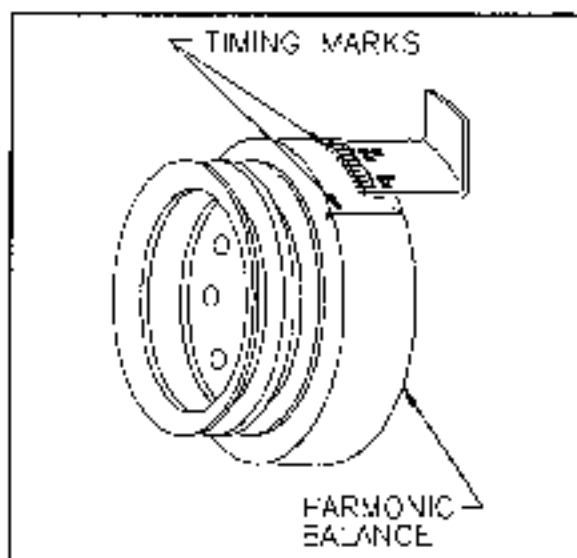

7. Tighten distributor clamp and hold in position when initial timing is obtained.
8. Plug in initial timing connector of MSTS harness.
9. Check total timing.
10. Disconnect and remove timing light.

DELCO IGNITION TIMING

Engine CID	Initial Timing @ 700 RPM	Total Timing @ 4000 RPM
454	12°	37°
502	12°	37°

MSTS SYMPTOM DIAGNOSIS AND DIAGNOSTIC CHARTS

PRELIMINARY CHECKS

Before using this section, you should verify the customer complaint, and locate the correct SYMPTOM. Check the items indicated under the symptom. Several of the following symptom procedures call for a careful visual/physical check.

The importance of this step cannot be stressed too strongly - it can lead to correcting the problem without further checks and can save valuable time. This check should include:

- Vacuum hoses for splits, kinks and proper connections.
- Air leaks at carburetor and intake manifold.
- Ignition wires for cracking, hardness, proper routing and carbon tracking.
- Wiring for proper connections, pinches and cuts. If wiring harness or connector repair is necessary, contact your dealer service manager for correct procedure. The following symptoms cover several engines. To determine if a particular component is used, refer to the ECM wiring diagrams for application. The ECM wiring diagram is located after the MSTS for application. The ECM wiring diagram is located after the MSTS diagnostic check.

INTERMITTENTS

Definition: Problems occur randomly.

DO NOT use the diagnostic charts for intermittent problems. The fault must be present to locate the problem. If a fault is intermittent, use of the diagnostic charts may result in replacement of good parts.

- Most intermittent problems are caused by faulty electrical connections or wiring. Perform careful check of suspect circuits for:
 - Poor mating of the connector halves, or terminals, not fully seated in the

connector body (backed out).

- Improperly formed or damaged terminals. All connector terminal in problem circuit should be carefully reformed or replaced to insure proper contact tension.
- Poor terminal to wire connection (crimping). This requires removing the terminal from the connector body to check.
- If a visual (physical) check does not find the cause of the problem, the MSTS system can be tested with a voltmeter connected to a suspected circuit.

An abnormal voltage reading, when the problem occurs, indicates the problem may be in the circuit.

- An intermittent may be caused by:
 - Electrical system interference caused by a sharp electrical surge. Normally, the problem will occur when the faulty component is operated.
 - Improper installation of electrical options, such as lights, 2-way radios, etc.
 - EST wires should be routed away from spark plug wires, ignition system components and generator. Wire for CKT 453 (reference low/system ground) from ECM to ignition system should be a good ground.
 - Secondary ignition shorted on ground.
 - Open ignition coil ground (coil mounting bracket) and arcing at spark plug wires or plugs.

HARD STARTING

Definition: Engine cranks O.K., but does not start for a long time. Engine does eventually run, or may start but immediately dies.

- Confirm proper fuel system operation.
- Visually (physically) check:
 - Vacuum hoses for splits, kinks and proper connections.
- Check ignition system for:
 - Proper output with ST-125
 - Worn distributor shaft
 - Bare or shorted wires
 - Pick-up coil resistance & connections
 - Loose ignition coil connections

HARD STARTING (Continued)

- Moisture in distributor cap
- Remove spark plugs. Check for cracks, wear, improper gap, burned electrodes or heavy deposits.
- If engine starts but then, immediately stalls, disconnect 4-wire EST connector at distributor. If engine then starts, and runs OK, replace distributor pick-up coil.
- Check CKT 423 (EST) for short to ground.
- Perform MSTS diagnostic check.
- Check base engine for:
 - Low compression
 - Incorrect valve timing

SURGES

Definition: Engine power variation, under steady throttle or cruise. Feels like the engine speeds up and slows down, with no change in the throttle control.

- Confirm proper fuel system operation.
- Visually (physically) check:
 - Vacuum hoses for splits, kinks and proper connections.
- Check ignition system for:
 - Ignition wires cracking, hardness and proper connections at both distributor cap and spark plugs.
 - Proper wiring connections, pinches and cuts.
 - 4-Terminal EST connector and wires near spark plug wires.
- Proper operation of EST.
 - Condition of distributor cap, rotor and spark plug wires.
 - Arcing to coil attaching screws in distributor cap.
 - Intermittent ground connection on ignition coil.
- Remove spark plugs. Check for cracks, wear, improper gap, burned electrodes or heavy deposits.
- Perform MSTS diagnostic check.

LACK OF POWER

Definition: Engine delivers less than expected

power. Little or no increase in speed, when throttle control is moved toward Wide Open Throttle (WOT).

- Confirm proper fuel system operation.
- Visually (physically) check:
 - Vacuum hoses for splits, kinks and proper connections
- Check ignition system for:
 - Ignition wires cracking, hardness or proper connections at both distributor cap and spark plugs.
 - Proper connections, pinches and cuts.
 - Initial engine timing.
 - Secondary ignition voltage, using a scope or ST-125.
 - EST-ESC operation. Perform MSTS diagnostic check.
- Check MAP sensor output. Refer to "Map Output Voltage Check" chart.
- Check exhaust system for restriction.

DETONATION / SPARK KNOCK

Definition: A mild to severe ping, usually worse under acceleration or heavy load. The engine makes sharp metallic knocks that change with throttle opening.

- Check for:
 - Obvious overheating problems.
 - Thermostat stuck shut.
 - For poor fuel quality, proper octane rating.
 - Spark plugs for correct heat range.
 - ESC system operation. Perform MSTS diagnostic check.
- Remove carbon with quality engine cleaner, follow instructions on can.
- Check base engine for excessive oil entering combustion chamber.

HESITATION

Definition: Momentary lack of response as the throttle is opened. Can occur at all engine speeds. May cause the engine to stall if severe enough.

- Confirm proper fuel system operation.
- Perform careful visual/physical check as described

HESITATION (Continued)

at start of "Symptoms".

- Check for:
 - Water contaminated fuel
 - Worn throttle linkage
 - Open reference low/system ground, CKT 453
 - Initial ignition timing incorrect
- Perform MAP output voltage check

CUTS OUT, MISSES

Definition: Steady pulsation or jerking that follows engine speed, usually more pronounced as engine load increases. The exhaust has a steady spitting sound at idle or low speed.

- Perform careful visual (physical) check as described at start of "Symptom Diagnosis".
- If ignition system is suspected of causing a miss at idle or cutting out under load.
- Check for the missing cylinder by using the following procedure:
 1. Start engine, allow engine to stabilize then remove one spark plug wire at a time, using insulated pliers.
 2. If there is a rpm drop on all cylinders (equal to within 50 rpm), go to "Rough, Unstable or Incorrect Idle, Stalling" symptom.
 3. If there is no rpm drop on one or more cylinders, or excessive variation in drop, check for spark, on the suspected cylinder(s) with J-26792 (ST-125) Spark Tester. If no spark, refer to "Ignition System Check" for further diagnosis. If there is a spark, remove spark plug(s) in affected cylinder and check for:
 - Cracks
 - Wear
 - Improper Gap
 - Burned Electrodes
 - Heavy Deposits
 4. If no problem was found in the above test, perform the following:
 - With the engine running, spray cap and plug wires with fine water mist to check for shorts.
 - Visually check distributor cap inside and out for moisture, dust, cracks and burns.

- Check pick-up coil.
- Base engine:
 - Remove rocker covers, check for bent pushrods, worn rocker arms, broken valve springs, worn camshaft lobes. Repair as necessary.
 - Check cylinder compression if in doubt.

STALLING, ROUGH, UNSTABLE or INCORRECT IDLE

Definition: The engine runs unevenly or rough at idle. Also, the idle may vary in rpm. Either condition may be severe enough to cause stalling. Engine idles at incorrect speed.

- Confirm proper fuel system operation.
- Visually (physically) check:
 - Vacuum hoses for splits, kinks and proper connections.
 - For air leaks at carburetor mounting and intake manifold.
- Check spark plug condition and gap.
- Check for:
 - Exhaust system restriction
 - Broken motor mounts
 - Correct initial ignition timing
- MAP sensor output voltage check.
- Check base engine for:
 - Low cylinder compression
 - Valve guide wear

DIESELING, RUN-ON

Definition: Engine continues to run after key is turned "OFF", but run very roughly. If engine runs smoothly, check ignition switch and adjustment.

- Check vacuum hoses for splits, kinks and proper connections.
- Check engine base idle speed.
- Remove carbon with quality engine cleaner. Follow instructions on can.
- Check for engine overheating.
- Check initial ignition timing.

POOR FUEL ECONOMY

Definition: Fuel economy is noticeably lower than expected.

- Check fuel system for proper operation.
- Visually/physically, check.
 - Vacuum hoses for splits, kinks and proper connections.
 - Ignition wires for cracking, hardness and proper connection.
- Check initial ignition timing.
- Remove spark plugs. Check for cracks, wear, improper gap, burr-ed electrodes or heavy deposits. Repair or replace as necessary.
- Perform MSTS diagnostic check.

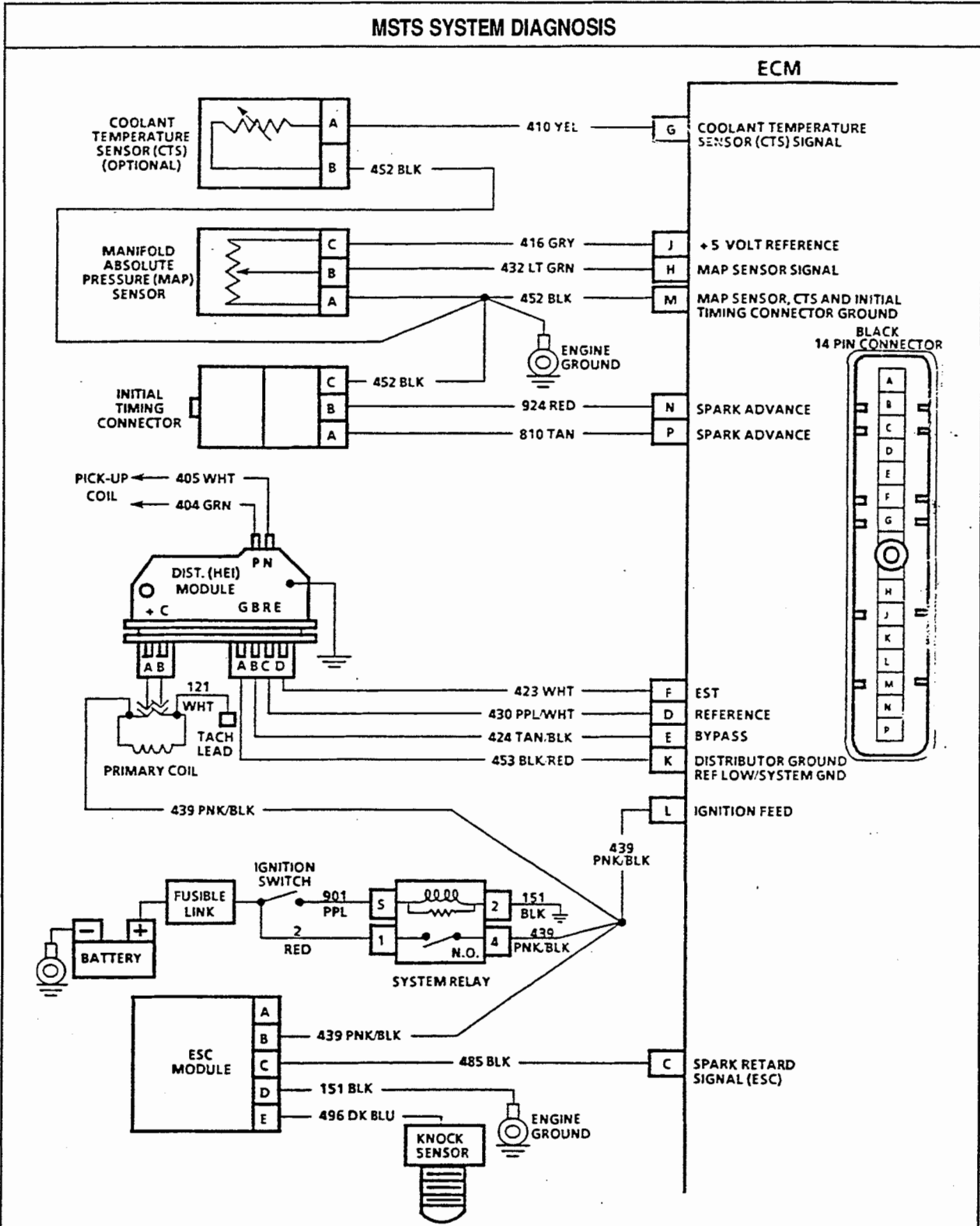

CONNECTOR IDENTIFICATION

This voltage chart is used with a digital voltmeter to further aid in diagnosis. The voltages you get may vary due to low battery charge or other reasons, but they should be very close.

THE FOLLOWING CONDITIONS MUST BE MET BEFORE TESTING:

- Engine at operating temperature
- Engine idling (for "Engine Run" column)

ECM CONNECTOR		CIRCUIT NUMBER & WIRE COLOR	COMPONENT CONNECTOR		NORMAL VOLTAGES	
PIN	FUNCTION		PIN	FUNCTION	KEY "ON"	ENG RUN
A	BLANK				0	0
B	BLANK				0	0
C	Spark Retard Signal (ESC)	485 BLK	C	Electronic Spark Control (ESC) Module	9.2	9.3
D	Reference	430 PPL/WHT	C	Distributor (HEI) Module	0	1.3
E	Bypass	424 TAN/BLK	B	Distributor (HEI) Module	0	4.75
F	EST	423 WHT	D	Distributor (HEI) Module	0	1.3
G	Coolant Temperature Sensor Signal	410 YEL	B	Coolant Temperature Sensor (CTS)	1.6	1.6
H	MAP Sensor Signal	432 LT GRN	B	Manifold Absolute Pressure (MAP) Sensor	4.75	1.1
J	MAP - 5 Volt Reference	416 GRY	C	Manifold Absolute Pressure (MAP) Sensor	5	5
K	Distributor Ground Reference Low (system ground)	453 BLK/RED	A	Distributor (HEI) Module	0	0
L	Ignition Feed	439 PNK/BLK	B	Electronic Spark Control (ESC) Module	B+	B+
M	Map Sensor, CTS, Initial Timing Connector Ground	452 BLK	A B C	Map Sensor, CTS, Initial Timing Connector	0	0
N	LP Gas Timing	924 RED	B	Initial Timing Connector	5	5
P	Gasoline Timing	810 TAN	A	Initial Timing Connector	5	5

REFER TO PAGE 5-4 FOR MSTS COMPONENT CONNECTIONS TO ECM DIAGRAM.

MSTS DIAGNOSTIC CHECK

The MSTS diagnostic check is an organized approach to an effective diagnosis and repair of the MSTS system. The diagnostic check should **always** be the starting point for any evaluation of the performance of the system, if the customer complaint exists. The diagnostic charts in this section assume that the entire fuel system and basic engine are in proper working order. If the proper operation of the fuel system or basic engine is in doubt, it must be repaired before using this section.

Test Description: Number(s) below refer to circled number(s) on the diagnostic chart.

1. This step determines if there is a problem with the basic distributor, coil assembly or power supply.
2. This step determines if the Electronic Spark Timing (EST) is working. Removing the jumper assembly when the engine is running removes the EST advance and the engine runs on initial timing.
3. This test will determine if the ESC system is functioning at this time. Usually a knock signal can be generated by tapping on the exhaust manifold. If no knock signal can be generated by tapping on the engine block, tap close to the area of the sensor.
4. This step checks to see if the MAP sensor is working correctly of if a problem is present.
5. The major components of the MSTS are functioning correctly. If the customer complaint still exists, refer to the "Symptoms" diagnosis immediately following the system diagnostic charts. If the system is equipped with a coolant sensor and the engine operates poorly when cold, refer to the "Coolant Sensor" diagnosis chart.
6. In addition to check the wire for an open, be sure to check the HEI module attaching screw. The MSTS is grounded through CKT 453.

MSTS DIAGNOSTIC CHECK DIAGNOSTIC CHART

IMPORTANT: BEFORE USING THIS CHART, THE FUEL SYSTEM SHOULD BE INSPECTED FOR PROPER OPERATION AND REPAIRED IF NECESSARY.

1 DOES THE ENGINE START?

YES

NO

2

- RUN ENGINE AT NORMAL OPERATING TEMPERATURE FOR 2 MINUTES.
- HOLD ENGINE SPEED STEADY AT 1500 RPM.
- REMOVE JUMPER ASSEMBLY FROM INITIAL TIMING CONNECTOR.
- DID A NOTICEABLE RPM DROP OCCUR WHEN JUMPER ASSEMBLY WAS REMOVED?

REFER TO "MSTS SYSTEM RELAY CHECK" CHART.

YES

NO

3

- RE-INSTALL JUMPER ASSEMBLY INTO INITIAL TIMING CONNECTOR.
- HOLD ENGINE SPEED STEADY AT 1500 RPM.
- TAP ON KNOCK SENSOR LIGHTLY.
- DOES A RPM DROP OCCUR WHILE TAPPING?

- IGNITION "OFF."
- DISCONNECT ECM CONNECTOR.
- CONNECT A TEST LIGHT TO GROUND.
- IGNITION "ON."
- TOUCH TEST LIGHT TO ECM HARNESS TERMINAL "L". IS TEST LIGHT "ON"?

YES

NO

YES

NO

4

- HOLD ENGINE SPEED STEADY AT 1500 RPM.
- DISCONNECT MAP SENSOR ELECTRICAL CONNECTOR.
- DID A ENGINE SPEED CHANGE OCCUR WHEN MAP CONNECTOR WAS DISCONNECTED?

- HOLD ENGINE SPEED STEADY AT 1500 RPM
- DISCONNECT KNOCK SENSOR ELECTRICAL CONNECTOR.
- DID A GRADUAL ENGINE SPEED INCREASE OCCUR?

- CONNECT A TEST LIGHT TO B +.
- TOUCH TEST LIGHT TO ECM HARNESS TERMINAL "K". IS TEST LIGHT ON?

REPAIR OPEN OR SHORT TO GROUND IN IGNITION FEED CIRCUIT.

NO

YES

6 REPAIR OPEN IN REFERENCE LO/SYSTEM GROUND CIRCUIT.

- IGNITION "OFF" RECONNECT ECM AND REFER TO "EST DIAGNOSIS CHART."

NO

YES

REFER TO "ESC DIAGNOSIS CHART."

CHECK ENGINE FOR EXCESSIVE MECHANICAL NOISE. IF NO ENGINE NOISE IS PRESENT, REPLACE KNOCK SENSOR.

YES

NO

5

- RECONNECT MAP SENSOR CONNECTOR.
- IGNITION "OFF."
- MSTS SYSTEM IS OK. PROBLEM IS INTERMITTENT.
- REVIEW CUSTOMER COMPLAINT AND REFER TO "SYMPTOMS" FOR FURTHER DIAGNOSIS.

REFER TO "MAP SENSOR DIAGNOSIS CHART."

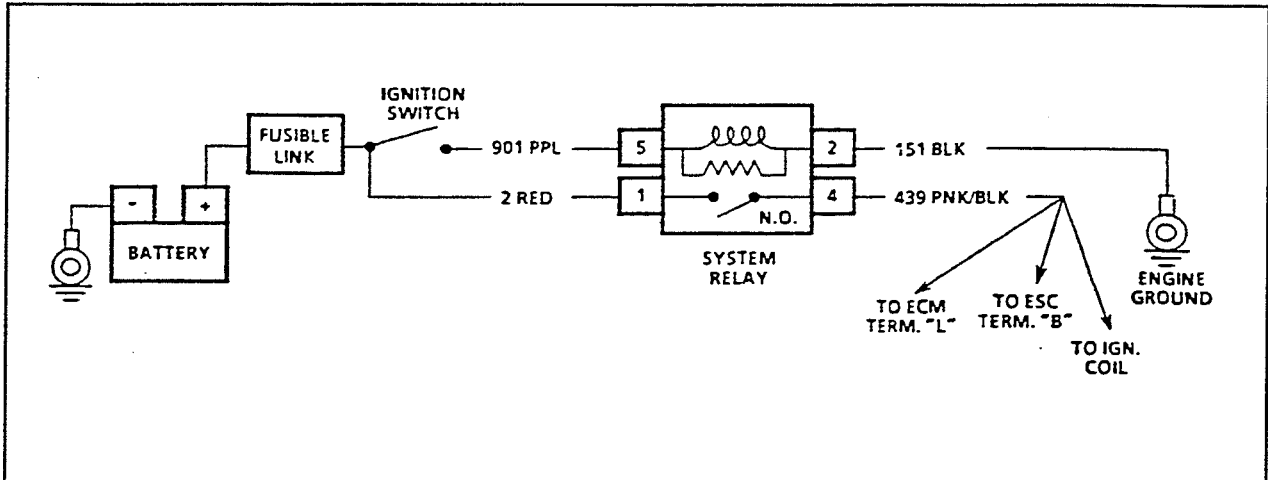

MSTS SYSTEM RELAY CHECK

Test Description: Number(s) below refer to circled number(s) on the diagnostic chart.

1. This step identifies if the relay is functioning properly. If a fault in the relay circuit were present, voltage would not be available at terminal "4" of the relay.
2. This step insures that battery and ignition voltage are available at the relay. An open or shorted condition in either supply would cause the relay not to operate.
3. This step insures that a good ground exists to terminal "2" of the system relay. An open ground to this terminal would not allow current to flow through the pull-in coil.
4. At this point, the circuits leading to the relay have been checked, and a careful visual inspection of the relay terminals should be performed prior to replacement of the system relay.

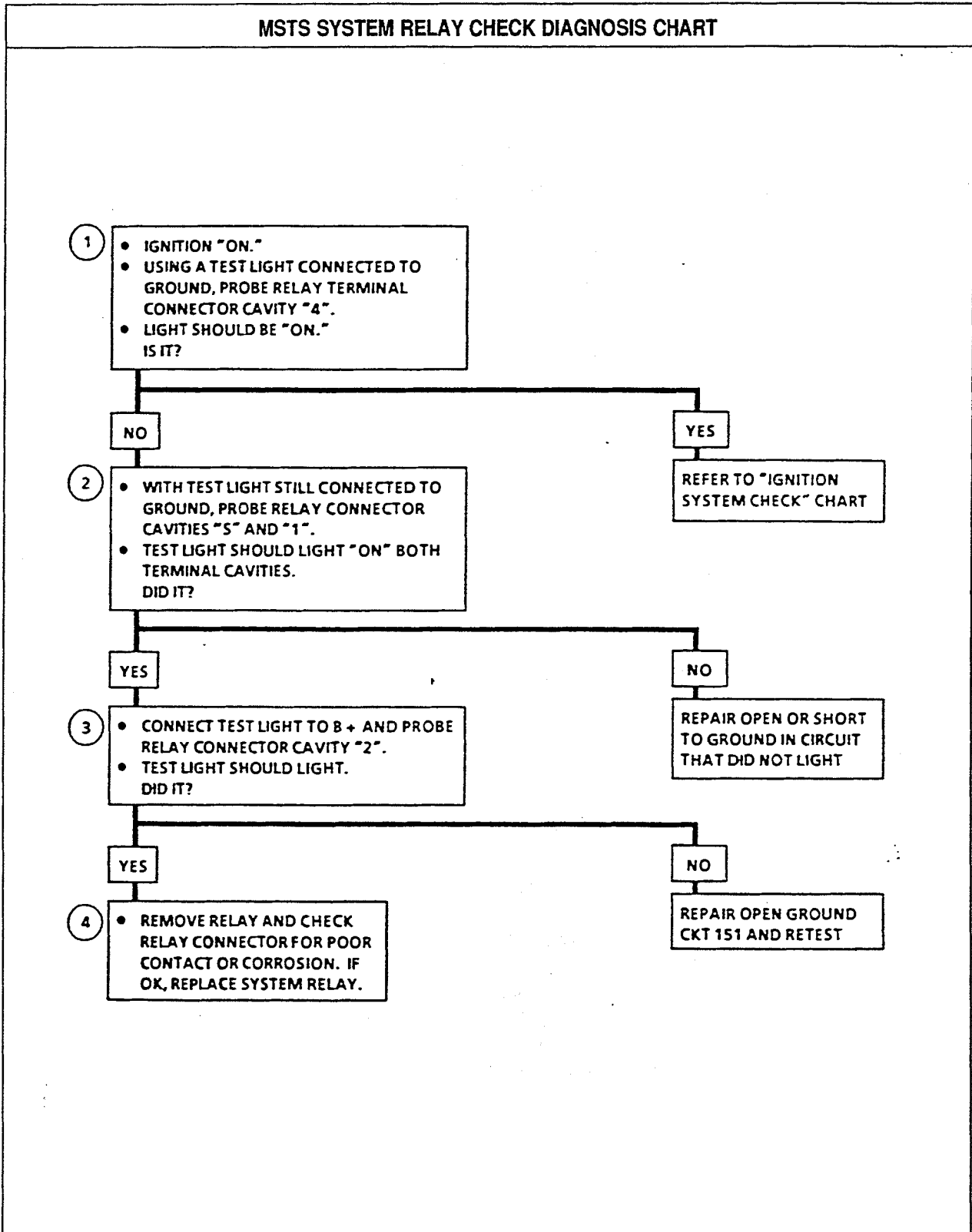

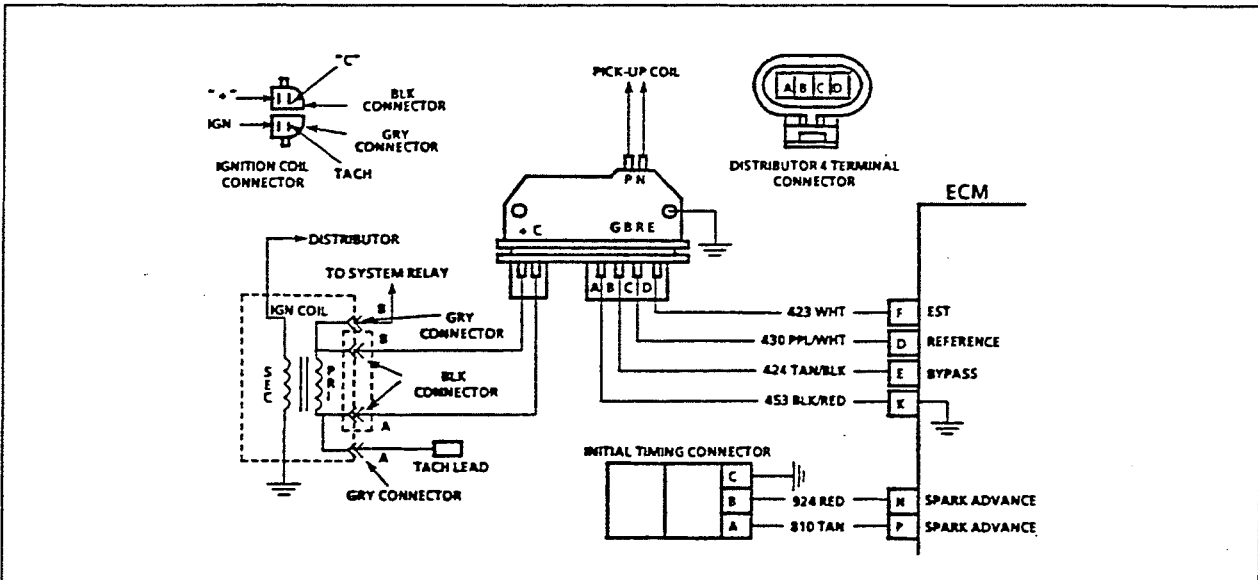

IGNITION SYSTEM CHECK (REMOTE COIL/SEALED MODULE CONNECTOR DISTRIBUTOR)

Test Description: Number(s) below refer to circled number(s) on the diagnostic chart.

1. Two wires are checked to insure that an opening is not present in a spark plug wire.
- 1A. If spark occurs with EST connector disconnected, magnetic output is too low for EST operation.
2. A spark indicates the problem must be the distributor cap or rotor.
3. Normally, there should be battery voltage at the "C" and "+" terminals. Low voltage would indicate an open or high resistance circuit from the distributor to the coil or ignition switch. If "C" terminal voltage was low, but "+" terminal voltage is 10 volts or more, circuit from "C" terminal to ignition coil or ignition coil primary winding is open.
4. Check for a shorted module or grounded circuit from the ignition coil to the module. The distributor module should be turned "OFF", so normal voltage should be about 12 volts. If the module is turned "ON", the voltage would be low, but above 1 volt. This could cause the ignition coil to fail from excessive heat. With an open ignition coil primary winding, a small amount of voltage will leak through the module from the "B+" to the "Tach" terminal.
5. Applying a voltage (1.5 to 8 volts) to module terminal "P" should turn the module "ON" and the "Tach" terminal voltage should drop to about 7-9

- vols. This test will determine whether the module or coil is faulty or if the pick-up coil is not generating the proper signal to turn the module "ON". This test can be performed by using a DC battery with a rating of 1.5 to 8 volts. The use of the test light is mainly to allow the "P" terminal to be probed more easily. Some digital multi-meters can also be used to trigger the module by selecting ohms, usually the diode position. In this position the meter may have a voltage across the terminals which can be used to trigger the module. The voltage in the ohms position can be checked by using a second meter or by checking the manufacturer's specification of the tool being used.
6. This should turn "OFF" the module and cause a spark. If no spark occurs, the fault is most likely in the ignition coil because most module problems would have been found before this point in the procedure. A module tester could determine which is at fault.

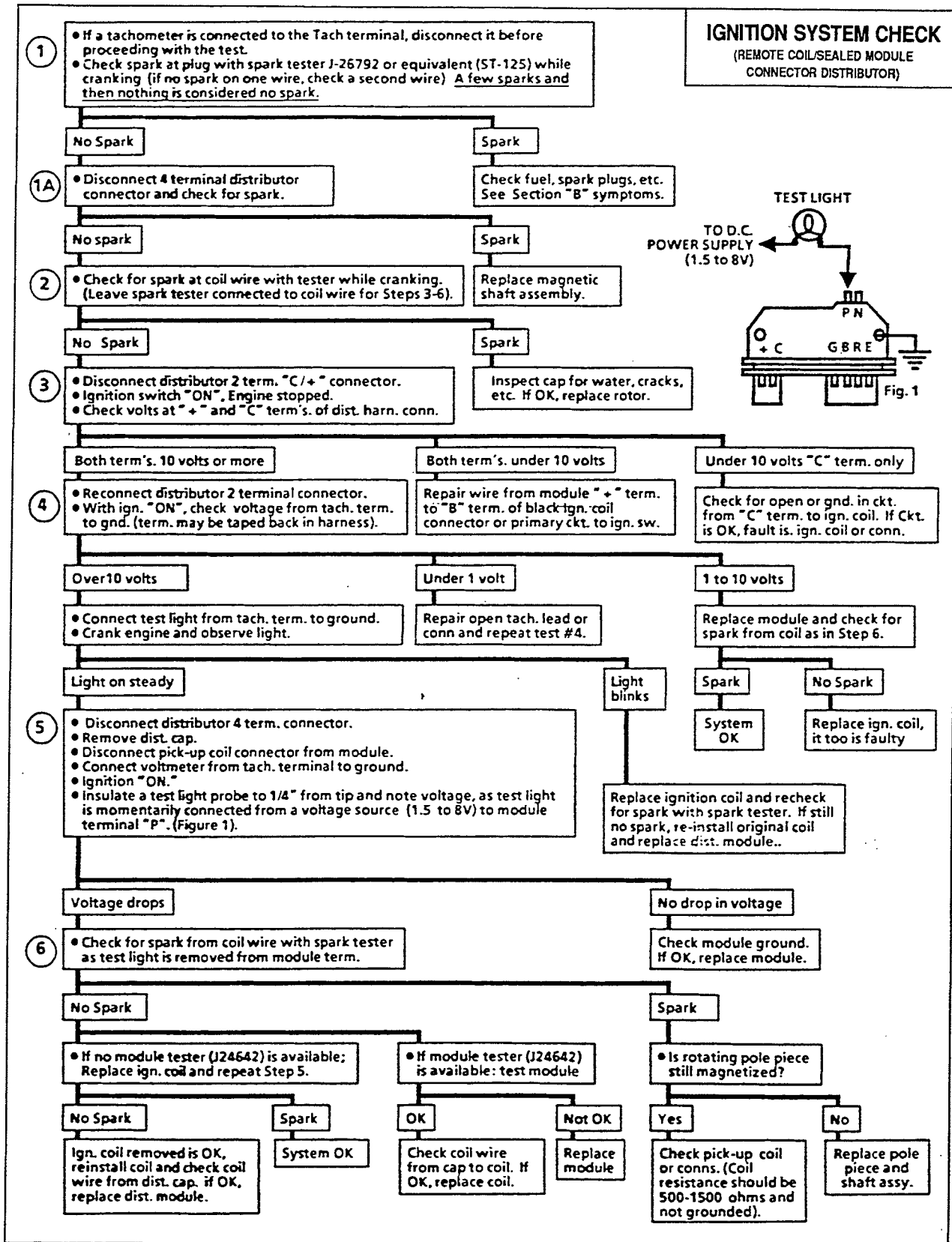

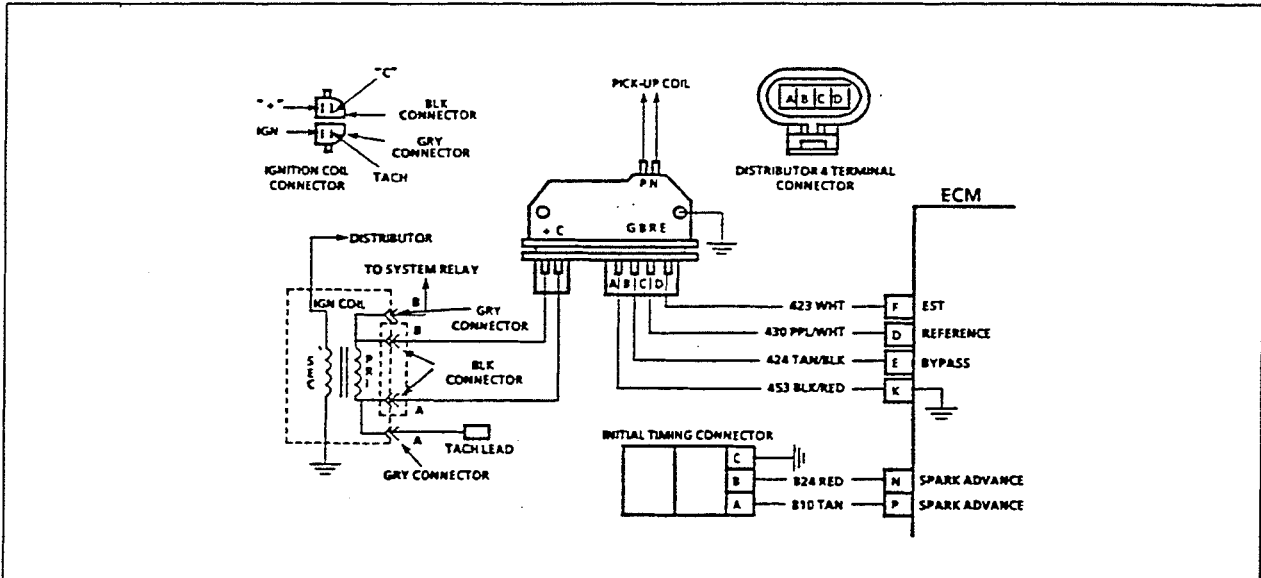

ELECTRONIC SPARK TIMING (EST) DIAGNOSTIC CHART

(Page 1 of 2)

Circuit Description: When the system is running on the ignition module, that is, no voltage on the bypass line, the ignition module grounds the EST signal. The ECM should not have voltage at the EST line during this condition. If it does, it will not go into the EST mode.

When the rpm for EST is reached (about 400 rpm), and bypass voltage applied, the EST should no longer be grounded in the ignition module so the EST voltage should be varying. If the bypass line is open or grounded, the ignition module will not switch to EST mode, and EST voltage will be low. If the EST line is grounded, the ignition module will switch the EST, but because the line is grounded there will be no EST signal.

Test Description: Number(s) below refer to circled number(s) on the diagnostic chart.

1. Removing the jumper assembly causes the timing to go to a fixed value. If timing varies with the increase in engine rpm (module advance), a problem is indicated. The ECM has seen an open or short to ground in the EST or bypass circuits.
2. This step insures that the initial timing connector circuitry is not open or shorted to ground.
3. This step checks to see if the ECM is receiving reference pulses from the ignition module. The

voltage value may vary slightly depending on closed throttle idle rpm. The important point is that there is a voltage present.

4. Check for normal EST ground path through the ignition module. An EST CKT 423 shorted to ground will also read less than 500 ohms; however, this will be checked later.

Diagnostic Aids:

- Check for the EST harness routed close to spark plug wires or other high load electrical harnesses.

IMPORTANT: PERFORM MSTS DIAGNOSTIC CHECK BEFORE USING THIS CHART.

ELECTRONIC SPARK TIMING (EST) DIAGNOSIS CHART

(Page 1 of 2)

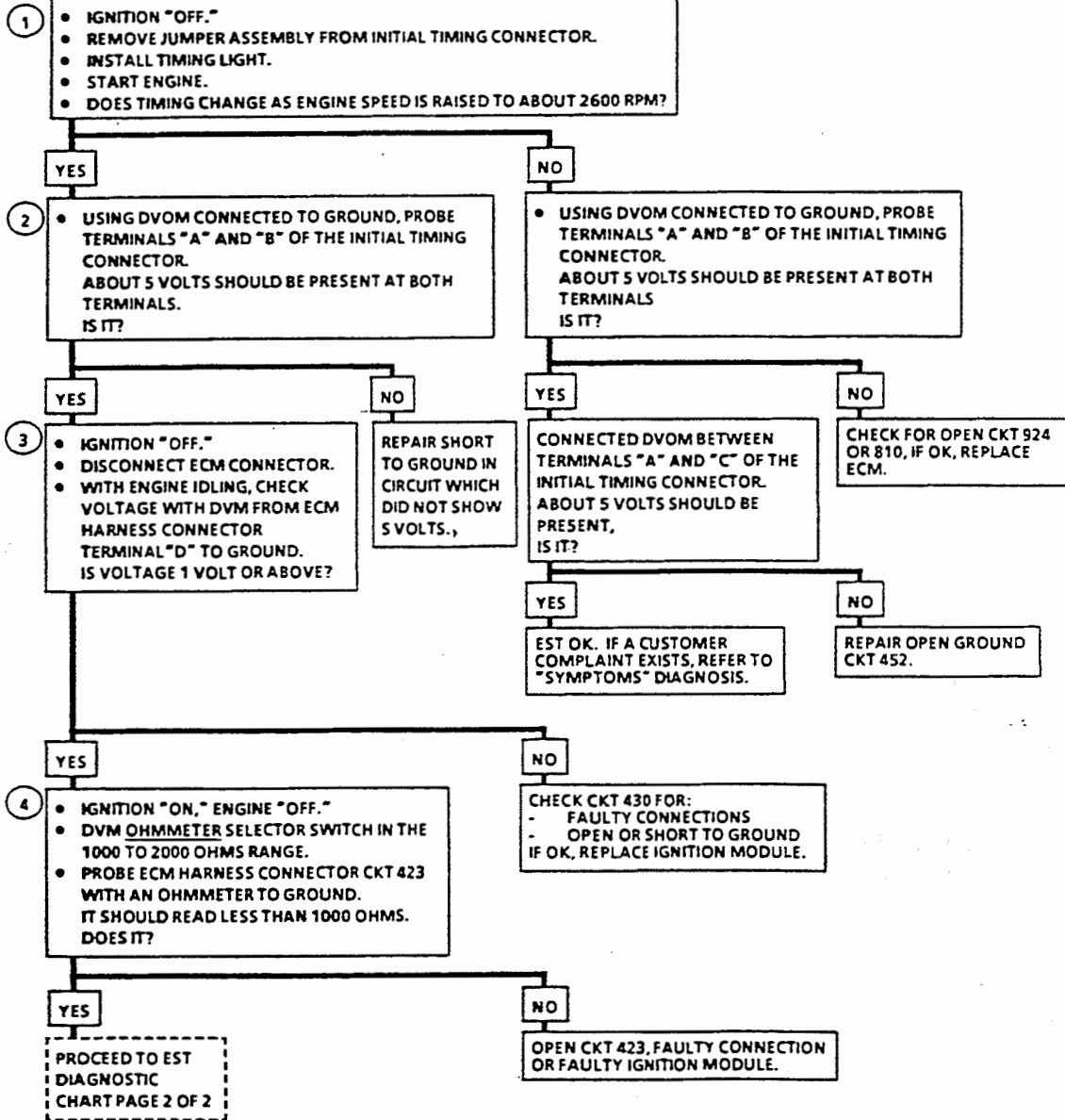

IMPORTANT: PERFORM MSTS DIAGNOSTIC CHECK BEFORE USING THIS CHART.

**ELECTRONIC SPARK TIMING (EST)
DIAGNOSIS CHART**

(Page 2 of 2)

FROM EST DIAGNOSTIC
CHART PAGE 1 OF 2.

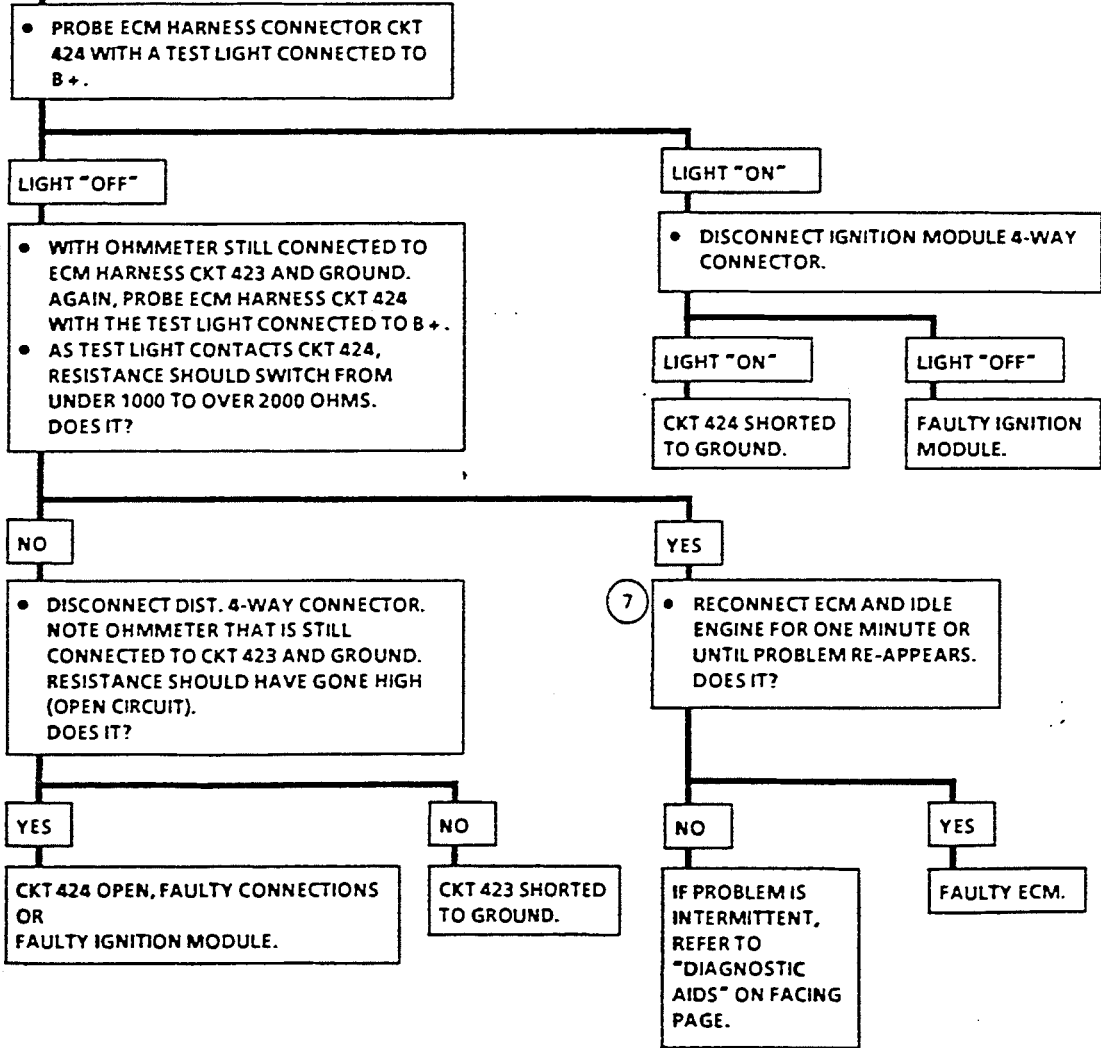

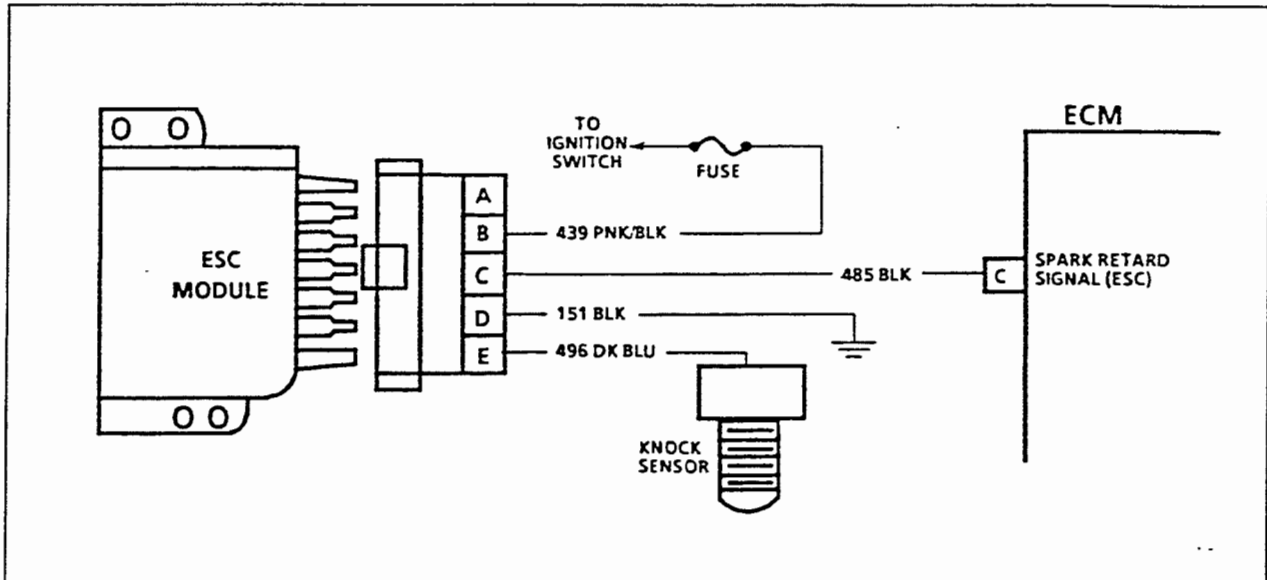

ELECTRONIC SPARK CONTROL (ESC) DIAGNOSTIC CHART

Circuit Description: Electronic Spark Control (ESC) is accomplished with a module that sends a voltage signal to the ECM. As the knock sensor detects engine knock, the voltage from the ESC module to the ECM drops, and this signals the ECM to retard timing. The ECM will retard the timing when knock is detected and rpm is above a certain value.

Test Description: Number(s) below refer to circled number(s) on the diagnostic chart.

1. This step insures that the knock sensor circuitry is within the proper resistance value.
2. This chart should have been entered from the MSTS diagnostic check where no response was seen when tapping on the engine block. Applying 12 volts with a test light to CKT 496 simulates a signal from the knock sensor. The knock sensor is faulty if a response occurs.
3. This step checks if a voltage signal from the ESC module is present at the ECM.
4. This step determines if ignition voltage is available to power up the ESC module.
5. This step confirms the ability of the ESC module to remove the voltage from the signal line when it

sees spark knock. Since the knock sensor produces an A/C voltage signal, it may be necessary to repeatedly touch the harness connector with the test light probe to simulate this type of signal.

6. This step checks the ground circuit from the ESC module. If the test light is dim, check ground (CKT 486) for excessive resistance.

Diagnostic Aids:

If CKT 496 is routed too close to secondary ignition wires, the ESC module may see the interference as a knock signal, resulting in false retard.

IMPORTANT: PERFORM MSTS DIAGNOSTIC CHECK BEFORE USING THIS CHART.

ELECTRONIC SPARK CONTROL (ESC) DIAGNOSIS CHART

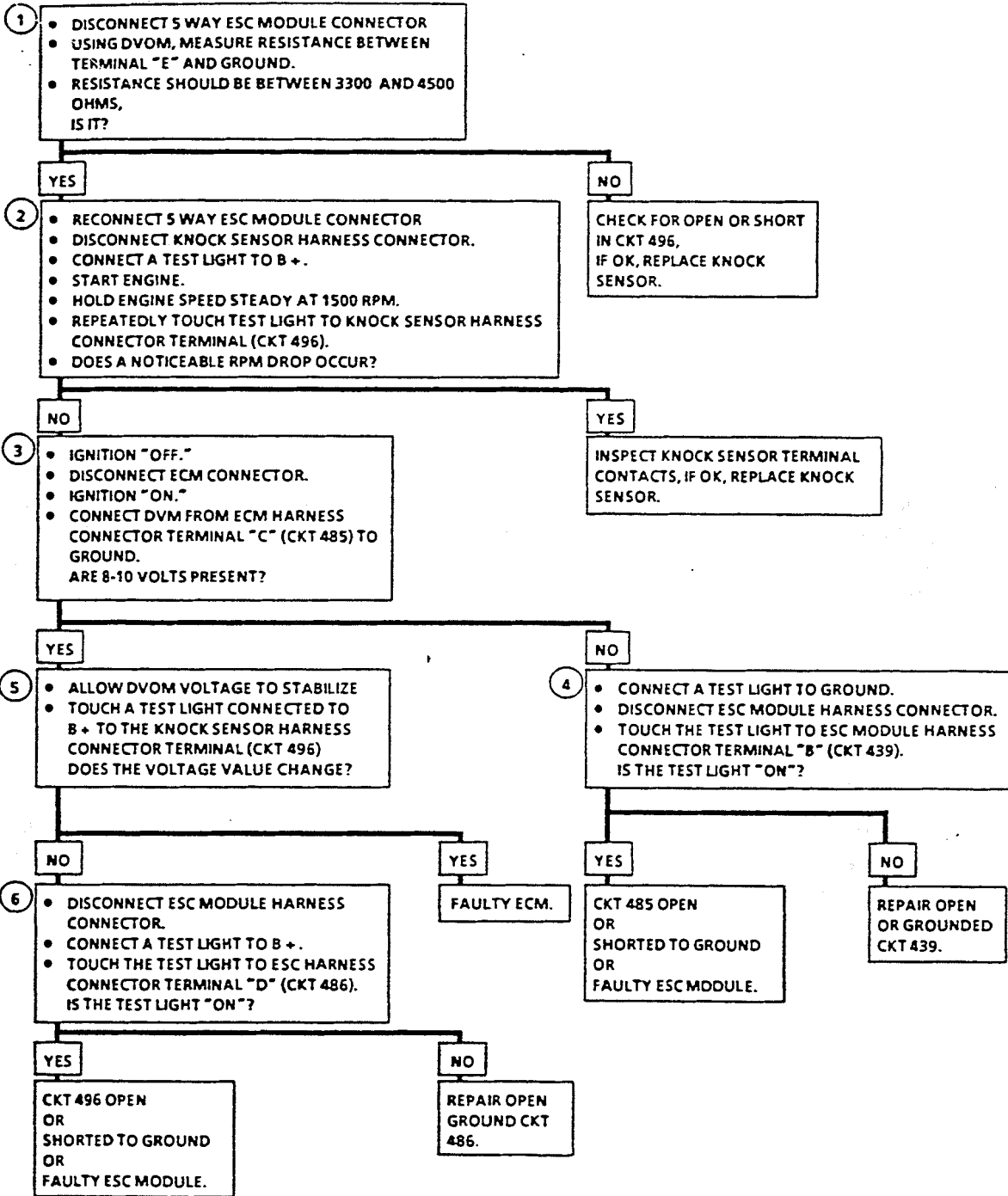

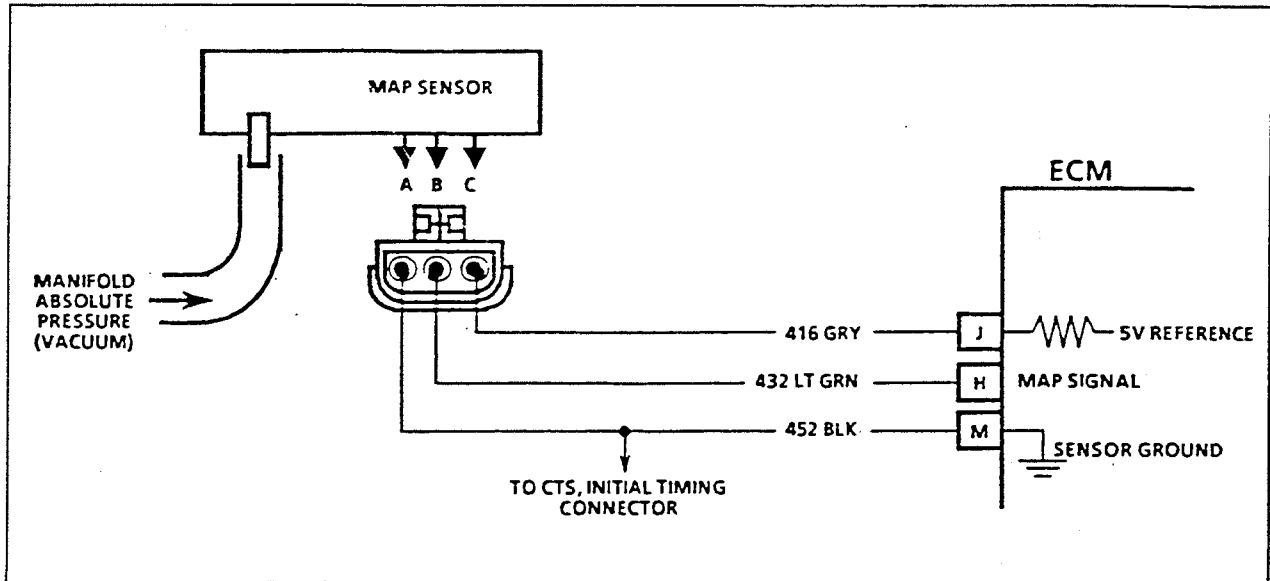

MANIFOLD ABSOLUTE PRESSURE (MAP) SENSOR DIAGNOSIS CHART

Circuit Description: The Manifold Absolute Pressure (MAP) sensor responds to change in the manifold pressure (vacuum). The ECM receives this information as a signal voltage, that will vary from 1-1.5 volts at idle to 4-4.5 volts at Wide Open Throttle (WOT). Low manifold pressure (high vacuum) will result in a low voltage signal which decreases spark advance, while a high manifold pressure (low vacuum) will result in a high voltage signal and increases spark advance. If the MAP sensors fail, the ECM will substitute a fixed MAP value.

Test Description: Number(s) below refer to circled number(s) on the diagnostic chart.

1. This step will determine if there is an adequate vacuum supply to the MAP sensor. If the gauge reading is erratic, refer to the "Rough or Unstable Idle" symptom.
2. Low manifold vacuum may result from a restriction in the MAP sensor hose or from vacuum leaks in the engine induction system.
3. This step checks for a voltage from terminal "C" (5 volt reference) to terminal "A" (sensor ground).
4. This step will isolate, whether the problem is in the wiring or the ECM.
5. This step determines if the MAP signal circuit to the ECM is open.
6. This step completes the test for the ECM and wiring. If the test light is not "ON", the MAP sensor has an internal problem. To confirm an internal MAP sensor problem, use the MAP output voltage check chart.

IMPORTANT: PERFORM MSTS DIAGNOSTIC CHECK BEFORE USING THIS CHART.

MANIFOLD ABSOLUTE PRESSURE (MAP) SENSOR DIAGNOSIS CHART

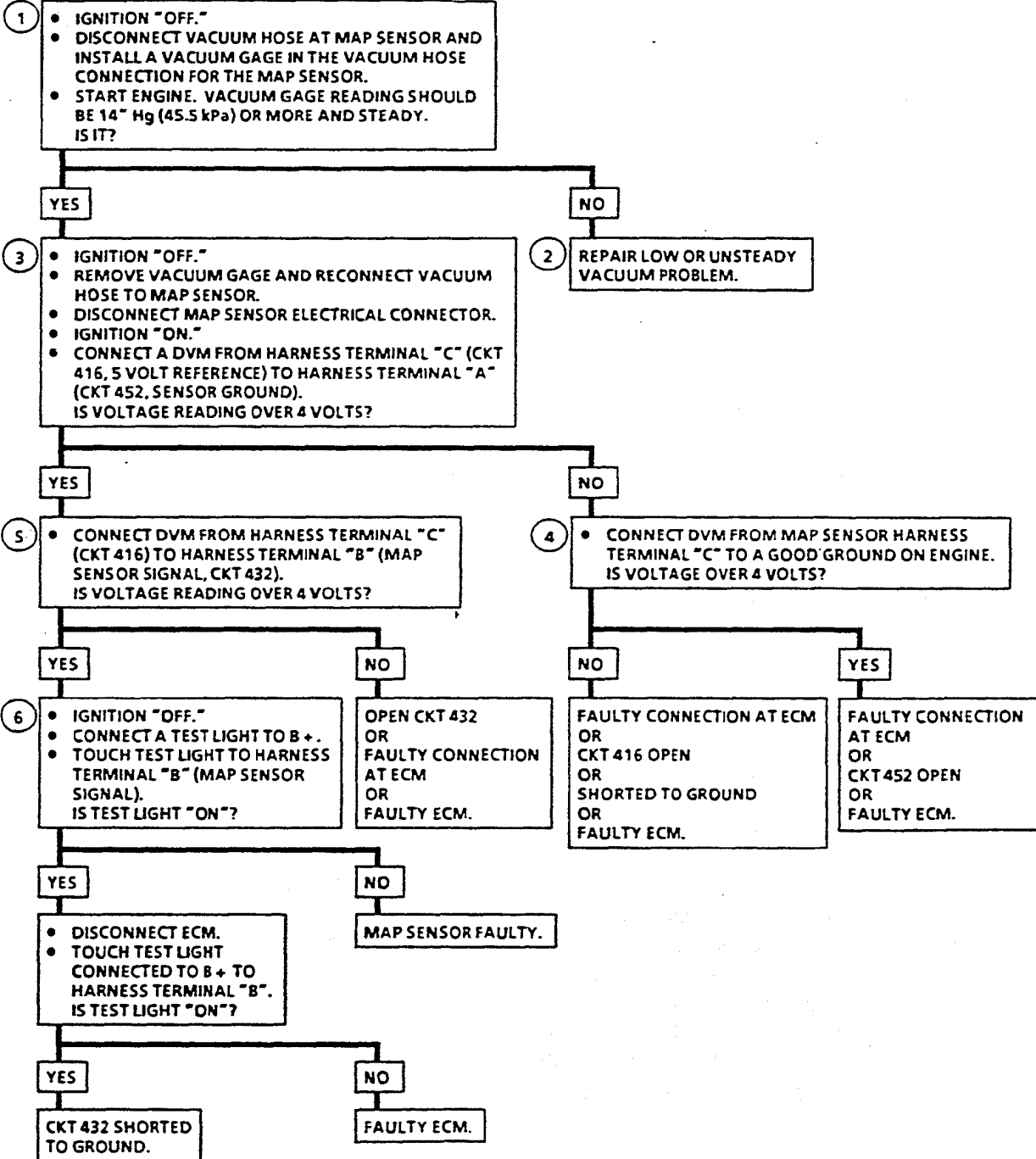

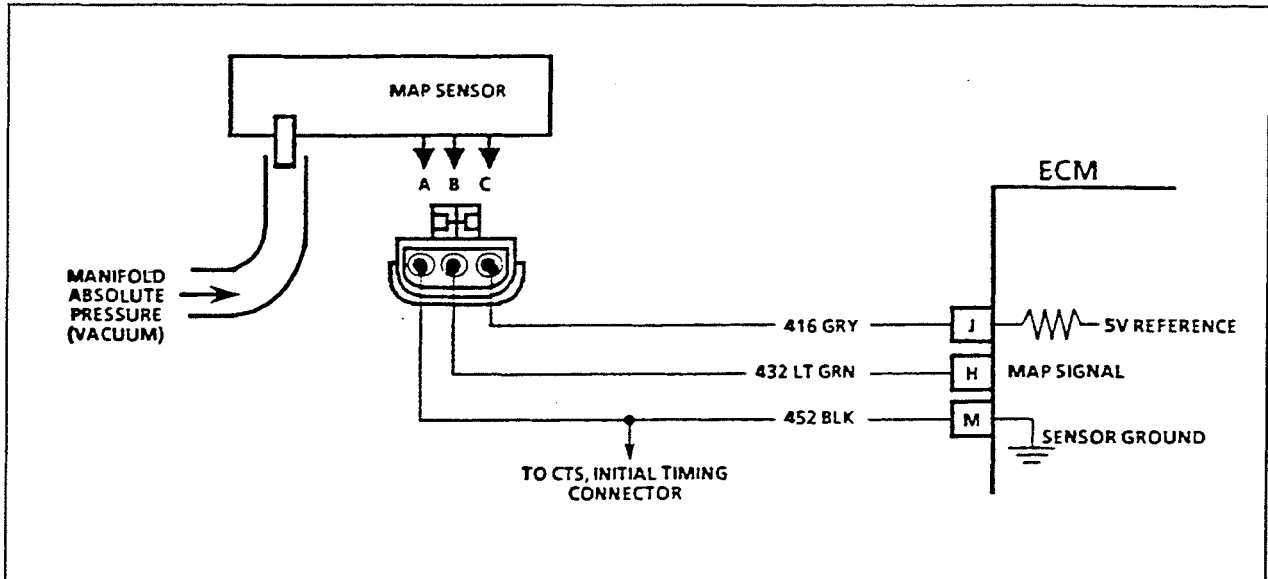

MANIFOLD ABSOLUTE PRESSURE (MAP) OUTPUT CHECK

Circuit Description: The Manifold Absolute Pressure (MAP) sensor measures the changes in the intake manifold pressure which result from engine load (intake manifold vacuum) and RPM changes; and converts this into a voltage output. As the manifold pressure changes, the electrical resistance of the MAP sensor also changes. The ECM sends a 5 volt reference voltage to the MAP sensor. As the manifold pressure changes, the signal voltage of the sensor to the ECM also changes. By monitoring the sensor signal voltage, the ECM knows the manifold pressure. A lower pressure (high voltage) signal will be about 1-1.5 volts at idle. While a higher pressure (high voltage) signal voltage will be about 4.5-4.8 at Wide Open Throttle (WOT). The MAP sensor is also used, under certain conditions to measure barometric pressure, allowing the ECM to make spark advance adjustments for different altitudes.

Test Description: Number(s) below refer to circled number(s) on the diagnostic chart.

IMPORTANT!! Be sure to use the same DVOM for all measurements.

1. Connect a jumper harness from MAP sensor to harness connector. This requires the use of three jumper wires between the MAP sensor and harness connector. They can be made using Terminal Test Adapter Kit J-35616. When comparing voltage readings to a known good MAP sensor, it is important to compare readings to a MAP sensor having the same color insert or having the same "Hot Stamped" number.
2. Applying 34 kPa (10" Hg) vacuum to the MAP sensor should cause the voltage to change. Subtract second reading from the first. Voltage value should be greater than 1.5 volts. Upon

applying vacuum to the sensor, the change in voltage should be instantaneous. A slow voltage change indicates a faulty sensor.

3. Check vacuum hose to sensor for leaking or restriction. Be sure that no other vacuum devices are connected to the MAP hose.
4. Disconnect sensor from bracket and twist sensor by hand (only) to check for intermittent connection. Output changes greater than .1 volt indicate a bad connector or connection. If OK, replace sensor.

Note: Make sure electrical connector remains securely fastened.

MANIFOLD ABSOLUTE PRESSURE (MAP) OUTPUT CHECK

NOTE: THIS CHART ONLY APPLIES TO MAP SENSORS HAVING GREEN OR BLACK COLOR KEY INSERT

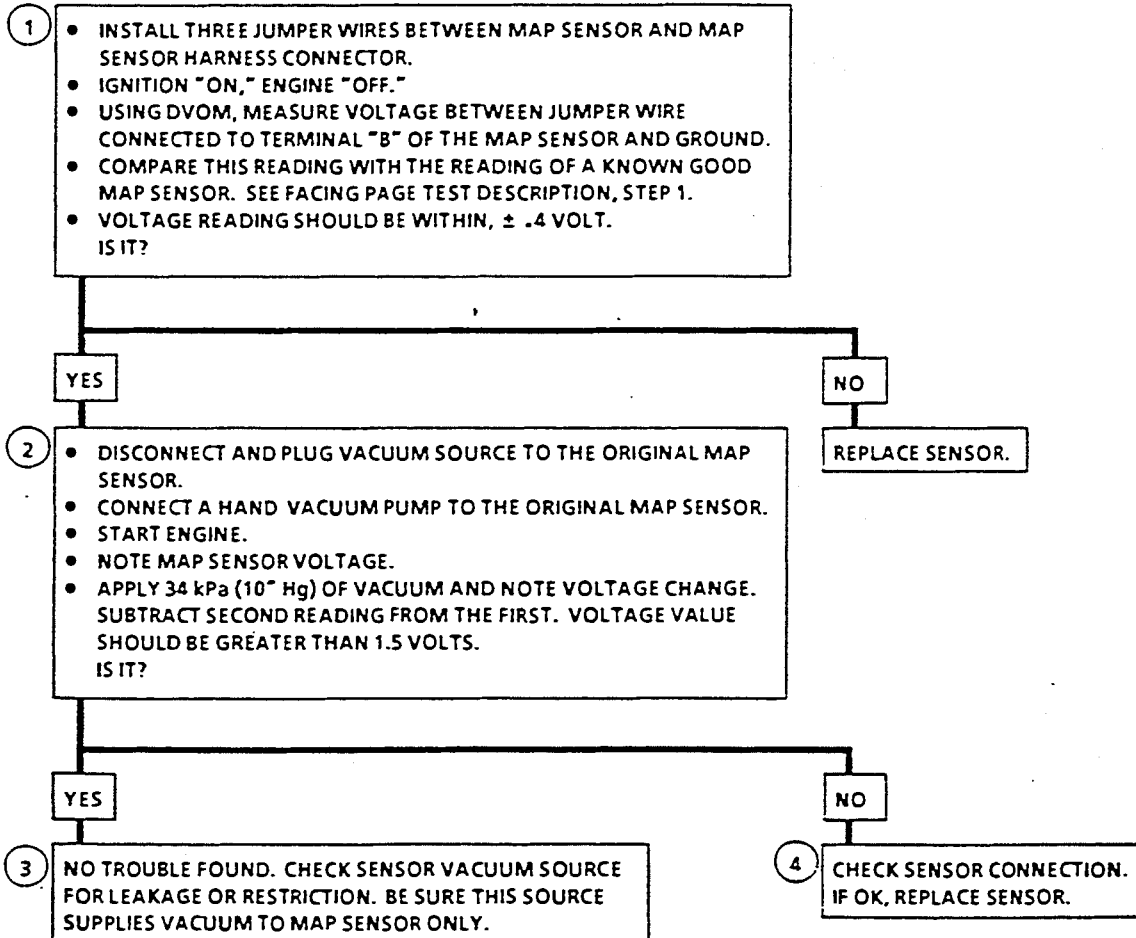

MANIFOLD ABSOLUTE PRESSURE (MAP) VOLTAGE/ALTITUDE COMPARISON (TYPICAL)	
ALTITUDE	* MAP SIGNAL VOLTAGE
SEA LEVEL	4.96
500	4.88
1000	4.78
1500	4.70
2000	4.60
2500	4.50
3000	4.42
3500	4.32
4000	4.24
4500	4.14
5000	4.06
5500	4.00
6000	3.90
6500	3.82
7000	3.74
7500	3.66
8000	3.56
8500	3.51
9000	3.44
9500	3.36
10000	3.28

* IGNITION "ON", ENGINE NOT RUNNING

* VOLTAGE VALUES MAY VARY (+) OR (-) 4 VOLTS

EFI

ELECTRONIC FUEL INJECTION

SECTION 6

Electronic Fuel Injection troubleshooting is beyond the scope of this manual. Due to the complexity of various EFI systems, Electronic Fuel Injection will not be covered in this manual.

To Purchase the EFI manual specific to your year model and type of engine, please Contact your local supplier. Be sure to note the year model, model number, serial number and application when calling.

FUEL

SECTION 7

CARBURETOR.....	3
Carburetor Replacement.....	3
Carburetor Rebuilding.....	3
Typical Exploded View Of Quadrajet Carburetor.....	4
Typical Exploded View Of Holley Carburetor.....	5
FUEL PUMP.....	7
Introduction.....	7
Mechanical Fuel Pump Replacement.....	7
Electric Fuel Pump Replacement.....	7
Fuel/Water Separator Filter Replacement.....	7
Carburetor Fuel Filter Cleaning/Replacement.....	8

CARBURETOR

CARBURETOR REPLACEMENT

Remove or Disconnect:

1. Battery negative cable.
2. Weather cover and crankcase ventilation hose on flame arrestor.
3. Flame arrestor.
4. Carburetor as follows:
 - Disconnect fuel line.

NOTE: Catch all residual fuel in the fuel line in a suitable container and remove from the work area! Any spilled fuel should be picked up with an absorbent towel and removed from the work area!

- Label and disconnect all vacuum lines, choke rods and electrical wires attached to carburetor.
- Disconnect throttle linkage and save all retaining caps.
- Unbolt and remove carburetor.

Clean or Inspect:

1. Manifold face and cover opening with a clean cloth.
2. Carburetor parts.

NOTE: Refer to "Carburetor Rebuilding" section in this manual.

Install or Connect:

1. Carburetor as follows:
 - Bolt carburetor to manifold.
 - Connect throttle linkage.
 - Connect vacuum lines, choke rods and electrical wiring.
 - Connect fuel line.
2. Flame arrestor.
3. Crankcase ventilation hose on flame arrestor.

4. Weather cover.
5. Battery negative cable.

CARBURETOR REBUILDING

NOTE: Carburetor should be removed from engine and rebuilt in a clean, dust-free area.

1. Rebuild carburetor as follows:
 - Disassemble carburetor and wash all parts in solvent.

NOTE: DO NOT wash any plastic, leather, rubber, electrical, etc. parts in solvent as damage will result. DO NOT leave parts in solvent for extended period of time.

- Rinse parts and blow dry with compressed air.
 - Check float needle and seat for wear, replace complete assembly if wear is discovered.
 - Check float hinge pin for wear and the float for dents or distortion. If fuel has entered float, replace float.
 - Check throttle and choke shaft bores for wear. **NOTE:** Replace throttle body if significant wear is discovered.
 - Check idle mixture adjusting needles for burrs or grooves. **NOTE:** If any wear or damage exists, replace needles.
 - Test accelerator pump check valves. The valves should pass air one way but not the other. Replace if necessary. Blowing through valve by mouth is sufficient for testing. **NOTE:** Rinse in solvent before reusing to remove moisture.
 - Check bowl cover for warped surfaces with a straight edge.
 - Inspect valves and seats for damage, replace as necessary.
2. Assemble carburetor and check all moving parts for freedom of operation.

TYPICAL EXPLODED VIEW OF QUADRAJET CARBURETOR	PART DESCRIPTION
<p>The diagram shows a detailed exploded view of a Quadrajet carburetor. The main body is at the top, with various jets and needles. Below it is the float bowl assembly, including the float, pump assembly, and needle and seat. The bottom section shows the choke housing and idle stop mechanism. Numerous callouts with numbers 1 through 72 point to specific components throughout the assembly.</p>	<ol style="list-style-type: none"> 1. Air Horn Assembly 2. Screw-Vent Valve Attaching 3. Idle Vent Valve Assem (Early Models) 4. Lever-Idle Vent Valve 5. Screw-Choke Lever Attaching 6. Lever-Choke 7. Link-Choke 8. Roll Pin-Pump Lever Hinge 9. Lever-Pump Actuating 10. Screw-Metering Rod Hanger Attaching 11. Hanger-Secondary Metering Rod 12. Rod-Secondary Metering 13. Plunger-Air Valve Dashpot (Early Models) 14. Screw Assem-Air Horn to Float Bowl 15. Screw Assem-Air Horn to Float Bowl (Long) 16. Screw-Air Horn to Float Bowl (Countersunk) 17. Gasket-Air Horn to Float Bowl 18. Float Bowl Assembly 19. Pump Assembly 20. Spring-Pump Return 21. Power Piston Assembly 22. Rod-Primary Metering 23. Retainer-Primary Metering Rod 24. Spring-Power Piston 25. Insert-Float Bowl 26. Hinge Pin-Float 27. Float Assembly 28. Needle & Seat Assembly 29. Pull Clip-Float Needle 30. Screw-Needle Diaphragm Retainer Attaching 31. Retainer-Needle Diaphragm 32. Needle & Diaphragm Assem (Early Models) 33. Jet-Primary Metering 34. Retainer-Pump Discharge Ball 35. Ball-Pump Discharge 36. Hose-Front Vacuum Break 37. Screw-Vacuum Break Attaching 38. Front Vacuum Break Assembly 39. Link-Air Valve 40. Screw-Choke Cover attaching 41. Retainer-Choke Cover 42. Choke Stat & Cover Assembly 43. Gasket-Stat Cover 44. Baffle Plate-Choke Stat 45. Screw Assem-Choke Housing Attaching 46. Choke Housing Assembly 47. Sea-Choke Housing to Float Bowl 48. Lever-Intermediate Choke 49. Screw-Stat Coil Lever Attaching 50. Lever-Stat Col 51. Intermediate Choke Shaft & Lever Assem 52. Cam-Fast Idle 53. Cup Seal-Intermediate Choke Shaft 54. Seal-Intermediate Choke Shaft 55. Screw-Compensator Cover Attaching 56. Cover-Idle Compensator 57. Idle Compensator Assem (Some Models) 58. Gasket-Compensator to Float Bowl 59. Nut-Fuel Inlet 60. Gasket-Fuel Inlet Nut 61. Filter-Fuel INlet 62. Spring-Fuel Filter 63. Screw-Idle Stop 64. Spring-Idle Stop Screw 65. Throttle Body Assembly 66. Screw Assem-Throttle Body to Float Bowl 67. Gasket-Throttle Body to Float Bowl 68. Rod-Pump 69. Needle-Idle Mixture 70. Spring-Idle Mixture Needle 71. Screw-Fast Idle 72. Spring-Fast Idle Screw

TYPICAL EXPLODED VIEW OF HOLLEY CARBURETOR

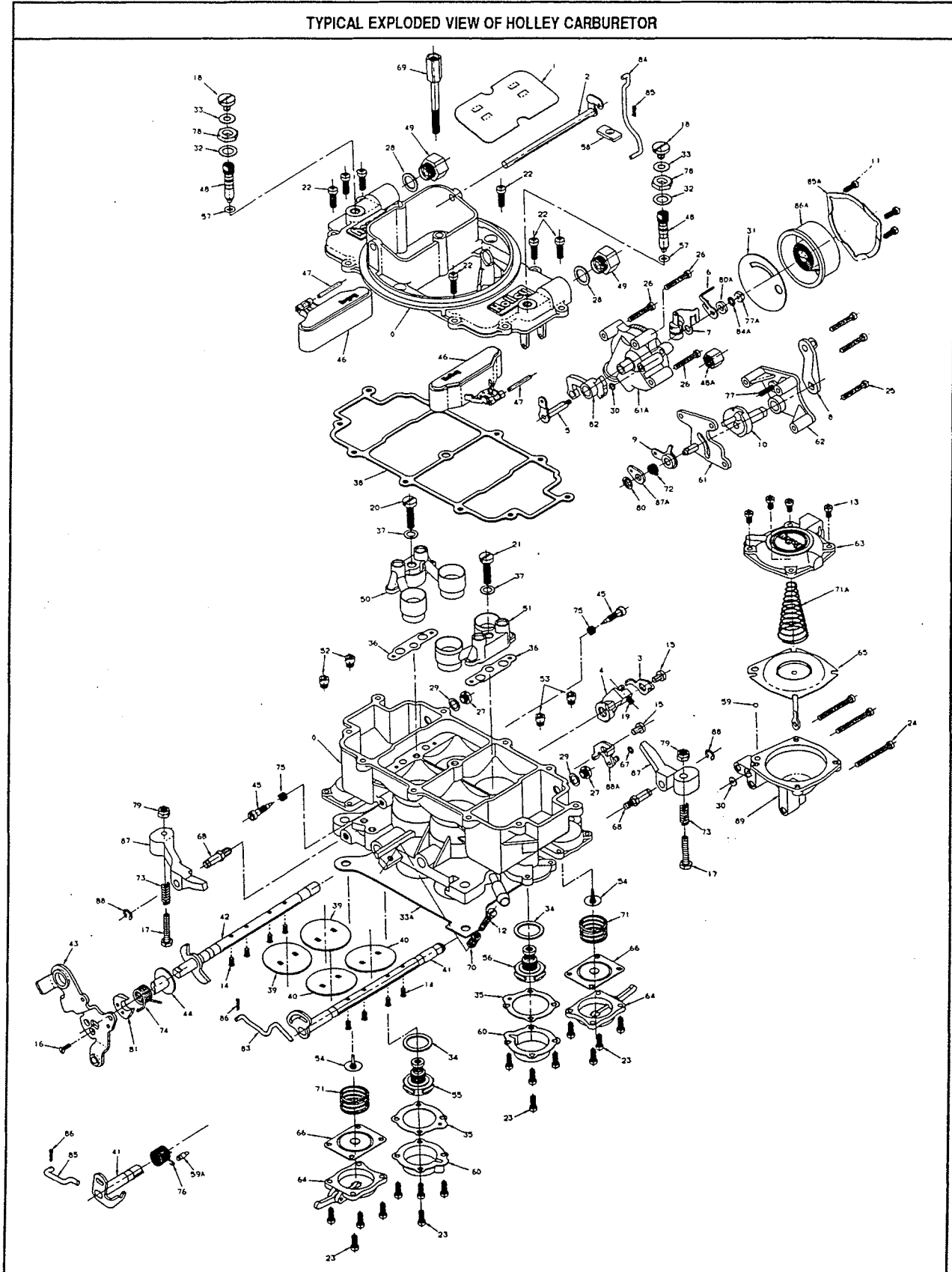

INDEX FOR EXPLODED VIEW OF HOLLEY CARBURETOR			
INDEX NUMBER	PART NAME	INDEX NUMBER	PART NAME
◇	Air Horn Assembly	51	Secondary Nozzle Bar Assembly
1	Choke Plate	52	Primary Main Jet
2	Choke Shaft and Lever Assembly	53	Secondary Main Jet
3	Cam Pick-up Lever	54	Pump Check Valve
4	Fast Idle Cam Lever†	55	Power Valve-Primary
5	Choke Housing Shaft and Lever Assembly††	56	Power Valve-Secondary
6	Choke Thermostat Lever††	57	O-Ring Seal
7	Thermostat Lever and Piston Assembly††	58	Choke Rod Seal
8	Choke Lever and Swivel Assembly†	59	Check Ball
9	Choke Rod Lever Molded†	59A	Throttle Return Spring Pin
10	Fast Idle Cam†	60	Power Valve Cover
11	Thermostat Cap Clamp Screw††	61	Choke Lever Back-up Plate Assembly†
12	Throttle Stop Screw	61A	Choke Housing & Plugs Assembly††
13	Secondary Diaphragm Cover Screw	62	Fast Idle Cam Plate Assembly†
14	Throttle Plate Screw	63	Secondary Diaphragm Cover
15	Fast Idle Cam Lever & Sec. Diaphragm Lever Screw & L.W.	64	Acc. Pump Diaphragm Cover Assembly
16	Pump Cam Screw	65	Secondary Diaphragm & Link Assembly
17	Pump Lever Adjustment Screw	66	Acc. Pump Diaphragm Assembly
18	Fuel Valve Seat Screw	67	E-Ring Retainer
19	Fast Idle Adjustment Screw	68	Pump Lever Stud
•	Secondary Idle Adjustment Screw	69	Air Cleaner Stud
20	Nozzle Bar Screw - Primary	70	Throttle Stop Adjusting Screw Spring
21	Nozzle Bar Screw - Secondary	71	Pump Diaphragm Return Spring
22	Air Horn Screw	71A	Secondary Diaphragm Spring
23	Pump Diaphragm Cover & Power Valve Cover Screw	72	Choke Lever Spring
24	Secondary Diaphragm Housing Screw	73	Pump Lever Adjustment Screw Spring
25	Fast Idle Cam Plate Screw†	74	Primary Throttle Return Spring
26	Choke Housing Screw††	75	Idle Adjustment Needle Spring
27	Fuel Level Check Plug	76	Secondary Throttle Return Spring
28	Fuel Inlet Fitting Gasket	77	Fast Idle Cam Spring†
29	Fuel Level Plug Gasket	77A	Hex Nut††
30	Secondary Diaphragm Housing & Choke Housing Gasket	78	Fuel Valve Seat Lock Nut
31	Thermostat Cap Gasket††	79	Fibre Lock Nut
32	Needle and Seat Adjustment Nut Gasket	80	Push Nut Fastener†
33	Seat Lock Screw Gasket	80A	Choke Thermostat Lever Spacer††
33A	Flange Gasket	81	Pump Cam
34	Power Valve Gasket	82	Fast Idle Cam Assembly††
35	Power Valve Cover Gasket	83	Secondary Connecting Rod
36	Nozzle Bar Gasket	84	Choke Rod
37	Nozzle Bar Screw Gasket	84A	Lockwasher††
38	Air Horn Gasket	85	Cotter Pin-Choke Rod
39	Primary Throttle Plate	85A	Thermostat Cap Clamp††
40	Secondary Throttle Plate	86	Cotter Pin-Throttle Connecting Rod
41	Secondary Throttle Shaft & Lever Assembly	86A	Thermostat & Cap Assembly Indexed††
42	Throttle Shaft and Stop Lever Assembly	87	Pump Operating Lever Assembly
43	Primary Throttle Lever	87A	Choke Spring Retainer Washer†
◇	Carburetor Body	88	E-Ring Retainer
•	Secondary Throttle Shaft Bushing	88A	Secondary Diaphragm Lever Assembly
44	Throttle Lever Bushing	89	Secondary Diaphragm Housing
45	Idle Adjustment Needle	•	J-Tube Bowl Vent
46	Float Shaft	•	Fuel Inlet Filter Screen
47	Fuel Inlet Needle and Seat Assembly		
48A	Compression Nut††		
49	Fuel Inlet Fitting		
50	Primary Nozzle Bar Assembly		

† For manual choke carburetors only

†† For automatic choke carburetors only

• These items are not shown on the typical view

CARBURETOR REBUILDING (Continued)

We recommend the following genuine Marine Power Carburetor Rebuild Kits:

Engine	Carburetor	MP Part #
350 CA	Holley	0702-450G1
V6 & V8	Rochester	0702-100G4
181	Holley 2 BBL	0703-100G10
181	Rochester	0703-100G4
181 RX	Holley	0703-150
	Holley 850 Perf.	0705-050

FUEL PUMP**INTRODUCTION**

Mechanical fuel pumps may be found on 181 CID ENPAC engines and all 350 CID engines. All other engines are equipped with electric fuel pumps. The mechanical fuel pump mounts on the side of the engine and is operated by the camshaft. The electric fuel pump is mounted in various locations on the engine depending on the application and is operated by the 12V DC source from the ignition.

MECHANICAL FUEL PUMP REPLACEMENT**Remove or Disconnect:**

1. Battery negative cable.
2. Weather cover.
3. Fuel line coming from the fuel/water separator.
4. Fuel line to carburetor.
5. Clear sight tube from carburetor.
6. Two bolts attaching pump to the block.
7. Fuel pump from block.
8. Push rod from block.

Clean or Inspect:

1. Fuel pump gasket from surfaces. *NOTE: It is essential that the gasket be replaced with a new one as a rupture in the gasket could cause the fuel and oil to mix thus diluting the engine oil.*
2. Push rod for scoring and pitting which may cause sticking.

Install or Connect:

1. Push rod into block. *NOTE: Coat with high temperature grease before installation.*
2. Fuel pump to block with bolts.

Tighten:

- Bolts to 27 N•m (20 ft.lbs.)

3. Clear sight tube to carburetor.
4. Fuel line to carburetor.
5. Fuel line to fuel/water separator.
6. Weather cover.
7. Battery negative cables.

ELECTRIC FUEL PUMP REPLACEMENT**Remove or Disconnect:**

1. Battery negative cable.
2. Weather cover.
3. Wires from electric fuel pump.
4. Fuel line from fuel/water separator.
5. Fuel line from carburetor.
6. Nuts holding pump to bracket.
7. Pump.

Install or Connect:

1. Fuel Pump.
2. Nuts attaching pump to bracket.
3. Fuel line to carburetor.
4. Fuel line to fuel/water separator
5. Wires to electric fuel pump.
6. Weather cover.
7. Battery negative cable.

FUEL/WATER SEPARATOR FILTER REPLACEMENT

IMPORTANT! Turn off fuel supply before performing procedure. Lay a towel or catch basin under filter to catch any spilled fuel. Dispose of properly.

FUEL/WATER SEPARATOR FILTER REPLACEMENT (Continued)

Remove or Disconnect:

1. Filter from header by turning counter clockwise with an oil filter wrench.

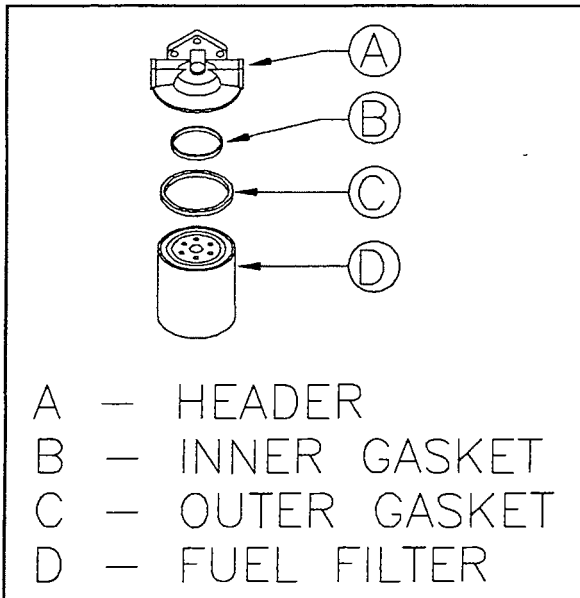

2. Old gasket from header contact surface, if necessary.

Clean or Inspect:

1. Gasket contact surface with a soft cloth.
2. Gasket contact surface for nicks, scratches or other surface imperfections.

Install or Connect:

1. New filter to header. **NOTE:** Lubricate gasket with clean engine oil, run filter up until gasket touches header and hand tighten 3/4 of one turn. Start engine and check for fuel leaks.

CARBURETOR FUEL FILTER CLEANING/REPLACEMENT

IMPORTANT! Turn off fuel supply before performing procedure. Lay a towel or catch basin under filter to catch any spilled fuel. Dispose of properly.

WARNING! DO NOT perform this task while engine is hot. Gasoline vapors are highly explosive under certain conditions.

Remove or Disconnect:

1. Fuel line connection at carburetor.

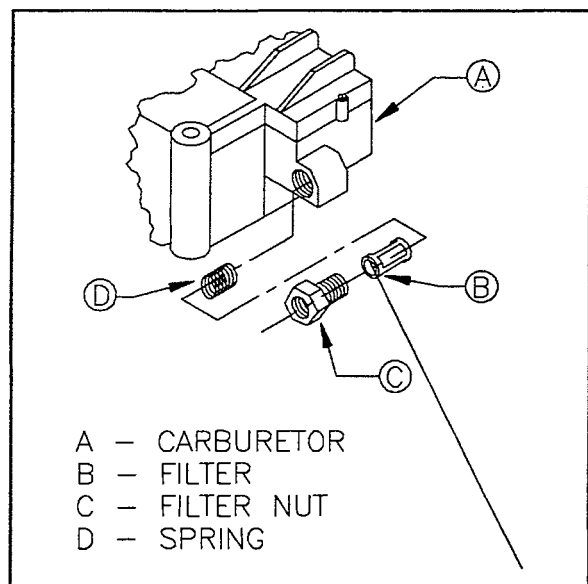

2. Fuel filter from carburetor.
3. Spring from carburetor.

Clean or Inspect:

1. Filter for damage or deterioration. Replace if necessary. **NOTE:** Most filters are reusable.
2. Filter, if reusable, in a suitable solvent and blow dry.
3. Spring for damage or corrosion. Replace if necessary.

**CARBURETOR FUEL FILTER
CLEANING/REPLACEMENT (Continued)****Install or Connect:**

1. Spring in carburetor.
2. Fuel filter in carburetor.
3. Fuel line connection to carburetor.

NOTE: Clean area of any spilled fuel, crank engine and check for leaks.

COOLING SYSTEMS

SECTION 8

INTRODUCTION.....	2
COOLING DIAGRAMS.....	3
Raw Water Cooling System - 181 CID.....	3
Raw Water Cooling System - 250 CID.....	4
Raw Water Cooling System - V6 & V8.....	5
Fresh Water Cooling System - 181 CID.....	6
Fresh Water Cooling System - 250 CID.....	7
Fresh Water Cooling System Front Mount - V6 & V8.....	8
Fresh Water Cooling System, Rear Mount - V6 & V8.....	9
TROUBLESHOOTING.....	10
FRESH WATER COOLING SYSTEM DRAIN POINTS DIAGRAMS.....	11
DRAINING COOLING SYSTEM, RAW WATER COOLING.....	12
DRAINING COOLING SYSTEM, CLOSED COOLING SYSTEM.....	12
ZINC ANODE REPLACEMENT (FRESH WATER COOLED ONLY).....	13
FILLING FRESH WATER COOLING SYSTEM.....	13
HEAT EXCHANGER PRESSURE CAP TEST.....	14
HEAT EXCHANGER PRESSURE CHECK.....	14
PRESSURE CHECKING FRESH WATER COOLING SYSTEM.....	14
FLUSHING RAW WATER COOLING SYSTEM.....	15

INTRODUCTION

Marine Power Engines are offered in two cooling configurations, raw water cooled and fresh water cooled. The raw water cooled system uses the water the boat is operating in to cool the engine. The raw water is pumped through a transmission/engine oil cooler into the thermostat housing. From the thermostat housing, it goes to the circulating pump, into the engine and back to the thermostat housing. The water then flows through the exhaust manifolds and is discharged overboard.

The fresh water system uses the raw water to carry the heat away from the separate fresh water coolant circulating through the engine. The raw water is pumped through a transmission/engine oil cooler, through the heat exchanger, through the exhaust riser(s) and is discharged overboard. The fresh water coolant is circulated through the system via the coolant circulating pump. The circulating pump draws the coolant from the heat exchanger, through the engine, into the exhaust manifold and back into the heat exchanger thermostat housing.

The heat exchanger on the 181 CID and the 250 CID engines are mounted on the starboard side opposite the manifold. A design change in the fresh water system was put into effect in the 1992 model year for the small and big block V-8 engines. The standard equipped fresh water system is now front mounted on the engine. This system was designed to replace the old rear mount fresh water system and has proven to be compatible for retrofit applications.

The following illustrations will give you a visual perspective of the coolant flow within the various engines and their configurations. It is important to know the flow within the entire coolant system when troubleshooting. Knowing the coolant flow will allow you to approach and troubleshoot a cooling system problem systematically and with minimal confusion or duplication of labor.

RAW WATER COOLING SYSTEM - 181 CID (3.0L)

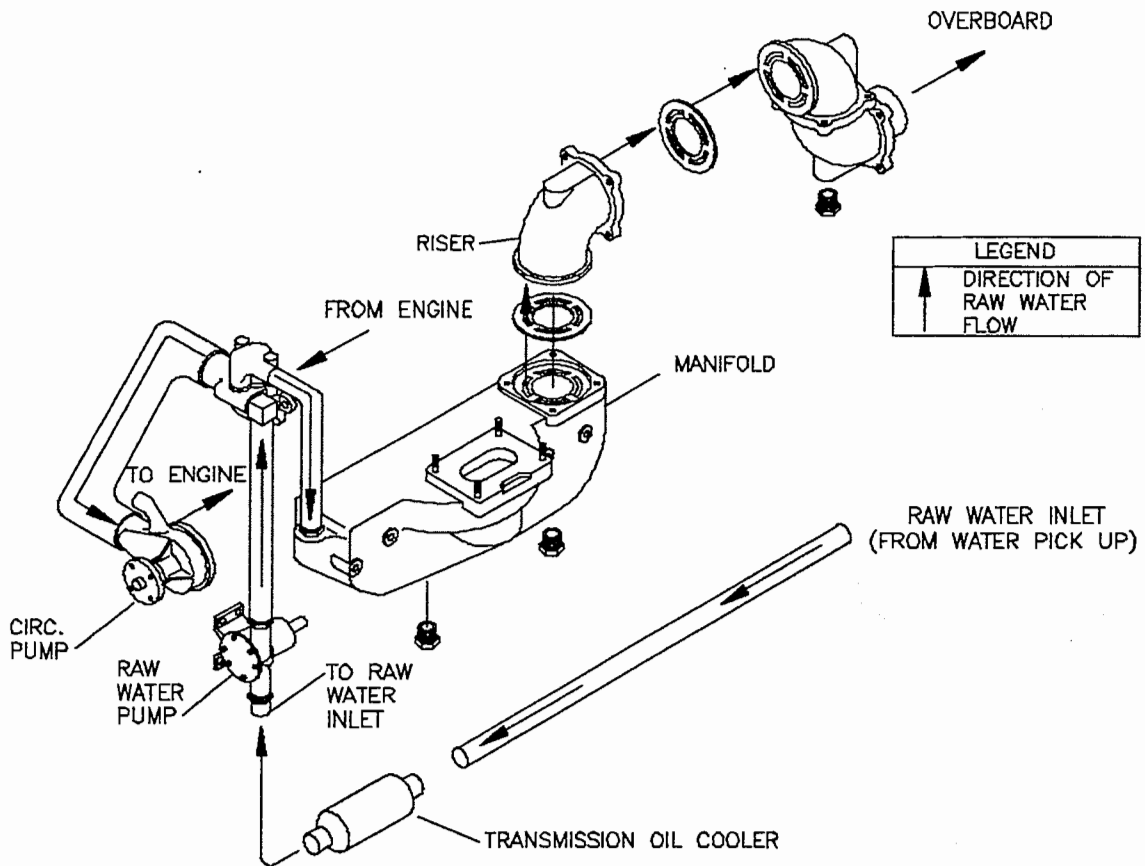

RAW WATER COOLING SYSTEM - 250 CID (4.1L)

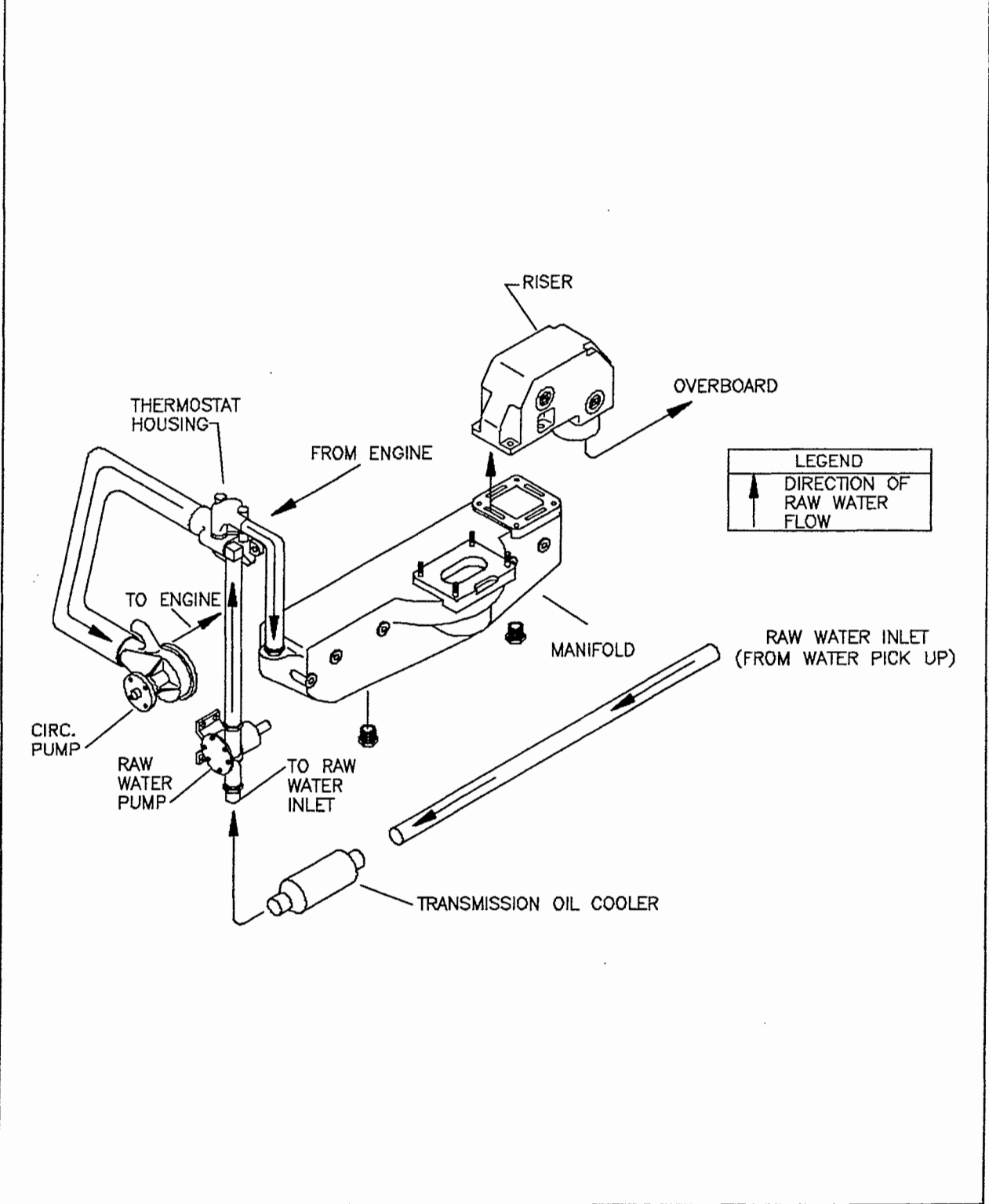

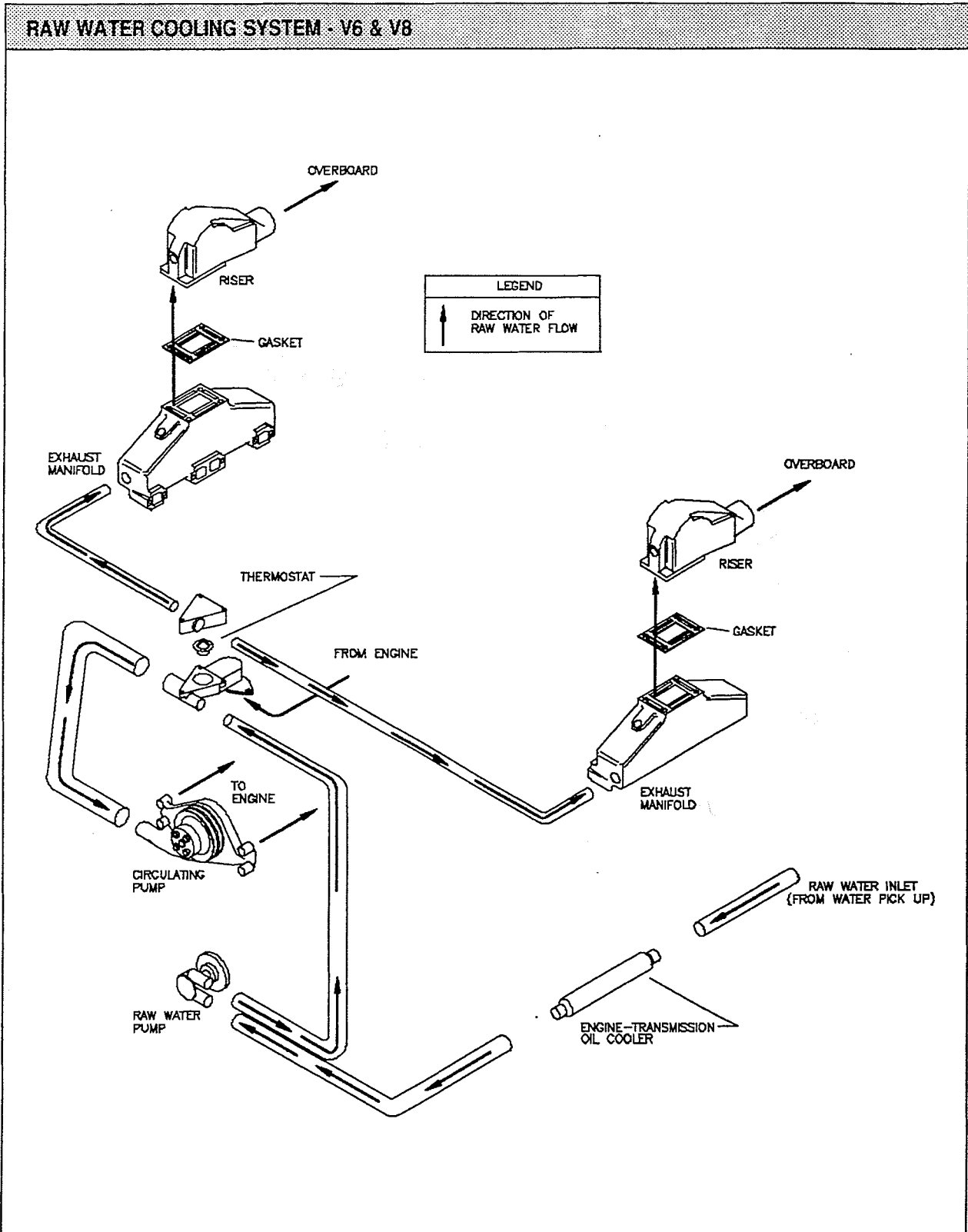

FRESH WATER COOLING SYSTEM - 181 CID (3.0L)

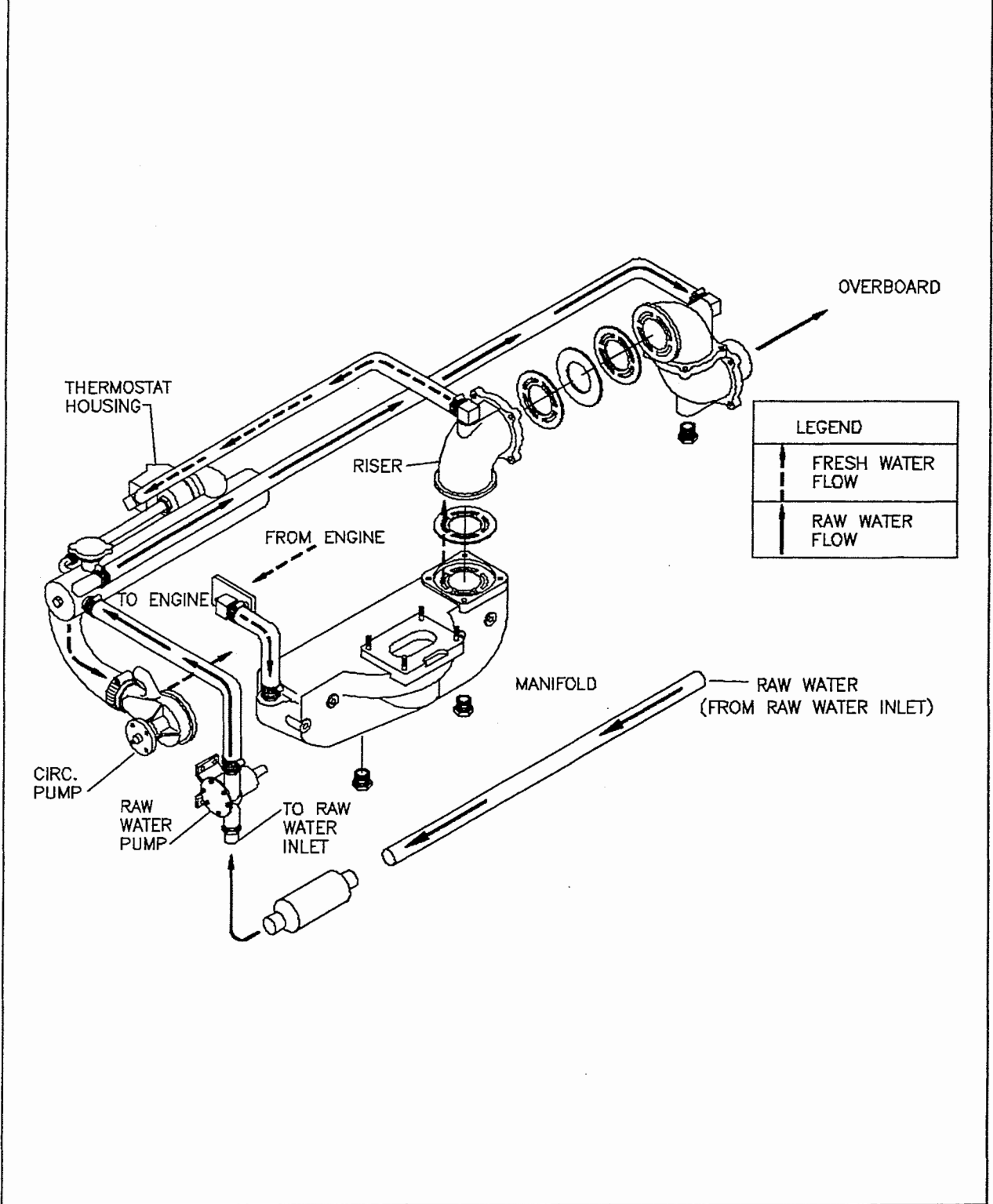

FRESH WATER COOLING SYSTEM - 250 CID (4.1L)

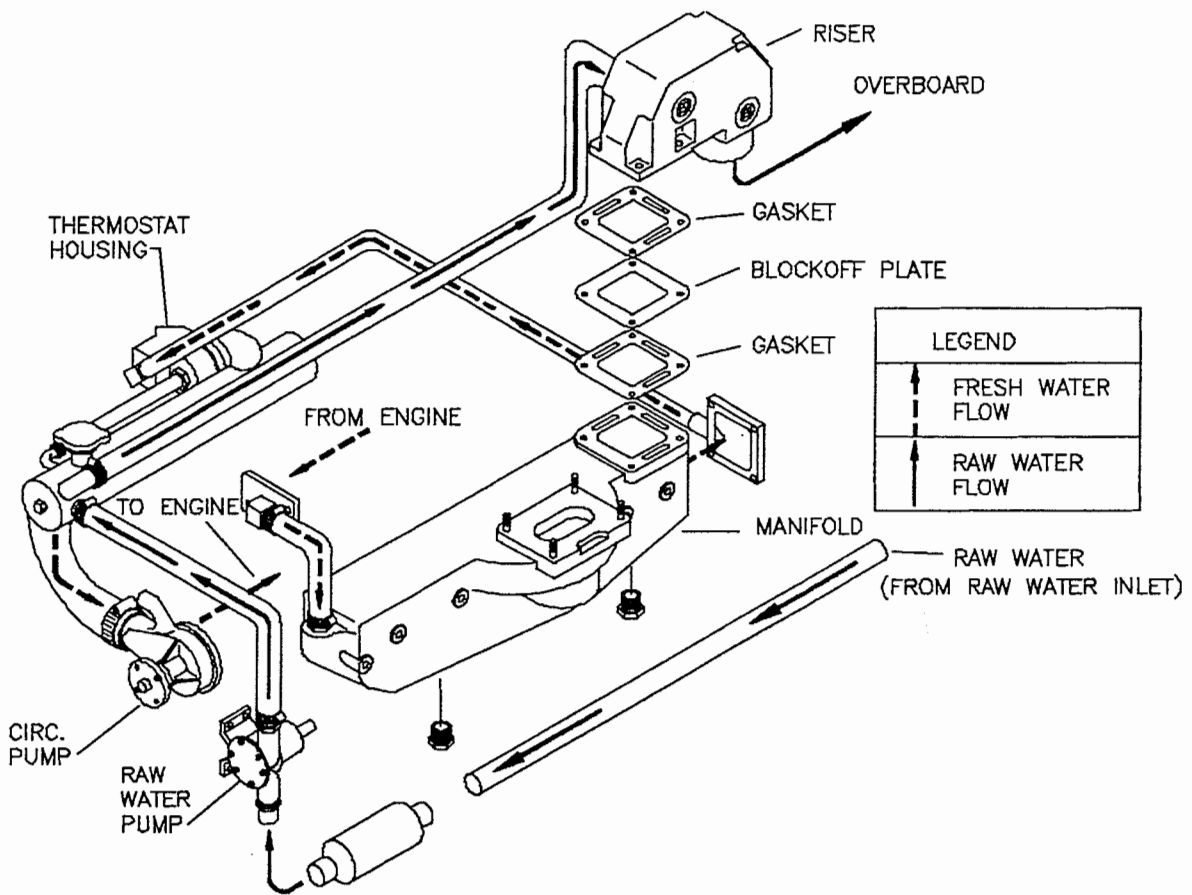

FRESH WATER COOLING SYSTEM, FRONT MOUNT - V6 & V8

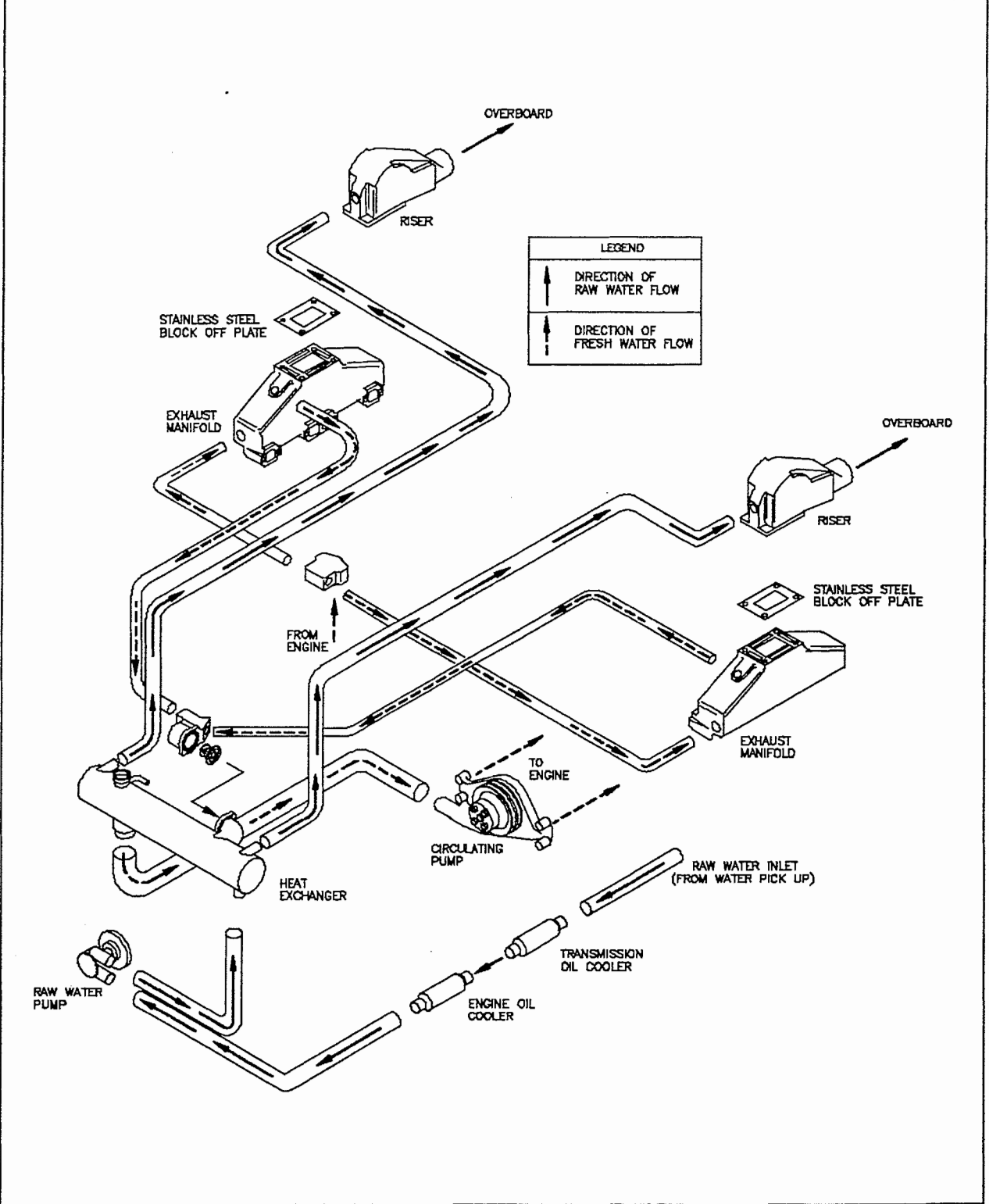

FRESH WATER COOLING SYSTEM, REAR MOUNT - V6 & V8

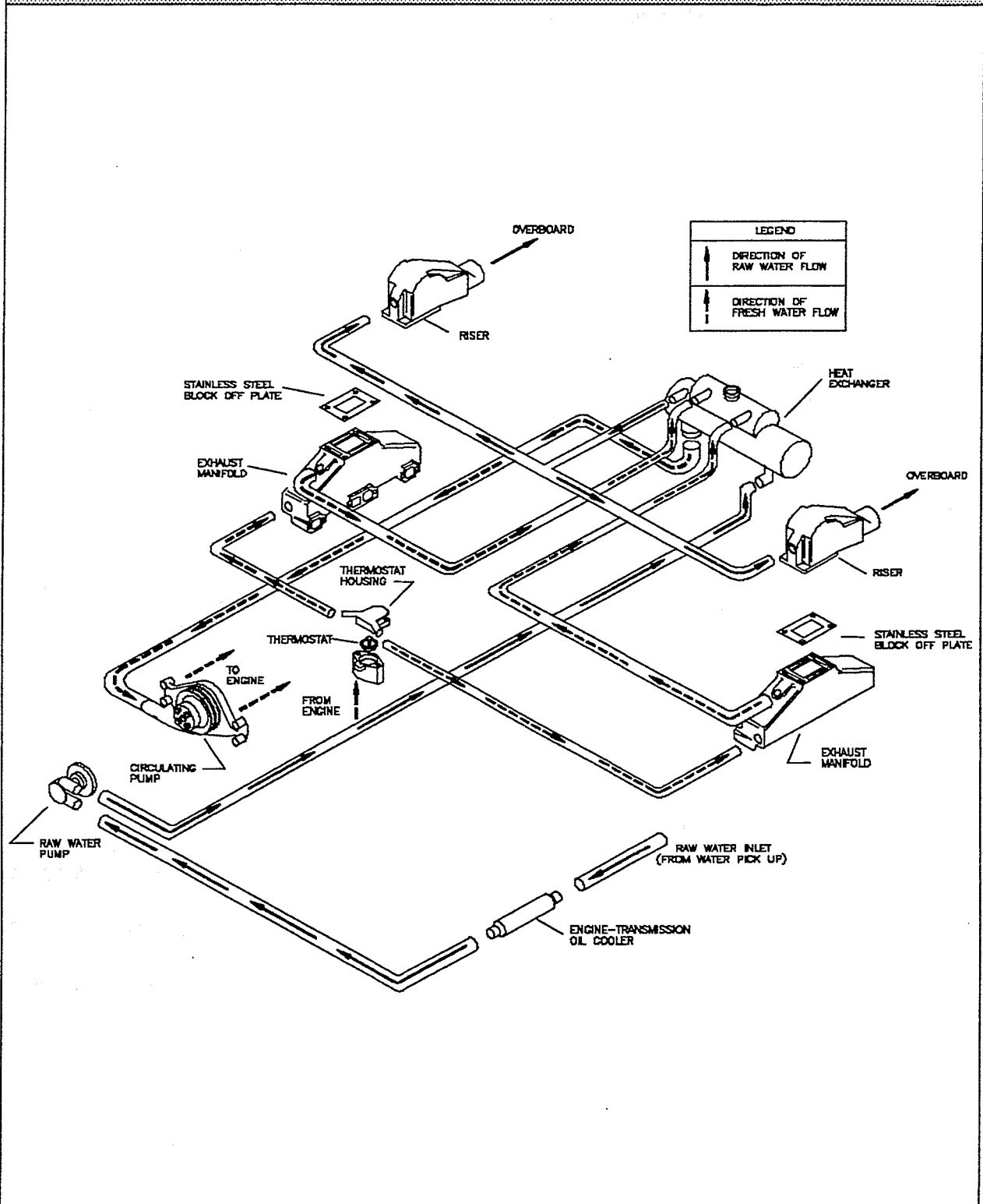

TROUBLESHOOTING:

When troubleshooting the coolant system, it is advisable to check the obvious first, such as broken belts, hoses, housings, manifolds, etc. If this does not resolve the problem, begin inspecting the system by following the water flow from the sea water pick-up to where the water is dumped overboard with the exhaust. The following steps will guide you through the coolant troubleshooting process.

ENGINE OVERHEATS	
Cause	Correction
<ul style="list-style-type: none"> • Loose or broken circulating pump belt • Inaccurate temperature gauge or temperature sending unit • Algae or barnacle build-up forward of water inlet, causing turbulence • Air entering system • Water circulating pump malfunctioning • Thermostat malfunctioning • Blockage in transmission/engine oil cooler • Impeller in raw water pump defective • Blockage in heat exchanger (sea water circuit) • Build up of scale and/or deposits in exhaust manifold or riser • Low coolant level in closed cooling system • Excessively high concentration of anti-freeze • Exhaust riser dump fittings contacting inner jacket of riser • Incorrect ignition timing • Detonation • Engine lugging/operating below proper rpms @ WOT • Fuel/air mixture too lean • Exhaust flappers stuck closed • Hot water heater improperly plumbed 	<ul style="list-style-type: none"> • Replace belt and tighten to specifications • Remove temperature sending unit on engine and attach a mechanical gauge. If operating temperature is normal, replace sending unit. • Remove build up • Pressure check radiator/tank cap. If defective, replace with dual seal type cap. • Replace circulating pump • Replace thermostat • Remove hose from water inlet side of cooler and check for and remove obstruction. • Replace impeller • Remove endplate on raw water side of heat exchanger, check for and remove obstruction from core tubing. • Remove manifold or riser and have them cleaned and serviced • Refill heat exchanger with proper mixture of coolant and add coolant to the overflow reservoir, fill to proper mark. • Drain coolant and refill with proper concentration (50/50) of antifreeze and water. <i>NOTE: Warm or hot climates may require a mixture of only pure soft water with a rust inhibitor.</i> • Remove fitting and replace with one have a shorter thread bearing surface • Tune engine according to "Tune-up Specifications" in this manual • Use spark plugs within proper head range or insure boat is operating within parameters • Check fuel/air mixture at carburetor, timing, propeller application, etc. • Adjust carburetor to proper specifications • Free flappers or replace if necessary • Plumb water heater according to manufacturer's specifications

WATER IN CYLINDERS	
Cause	Correction
<ul style="list-style-type: none"> • Water washes back up through exhaust system and enters the cylinders • Blown cylinder head gasket • Cylinder head bolts loose • Cracked exhaust manifold 	<ul style="list-style-type: none"> • Ensure exhaust system is installed with proper slope and avoid abrupt power reductions which cause the wake to wash high upon the transom • Replace gasket and have cylinder block and head checked for warpage • Retorque head bolts and run engine, check for water in cylinder(s) • Remove manifold and have it repaired if possible

IMPORTANT! Do not use aftermarket cooling system sealers to seal leaks in marine cooling systems as this will lead to blockage and overheating in the engine or manifolds.

FRESH WATER COOLING SYSTEM DRAIN POINTS DIAGRAMS

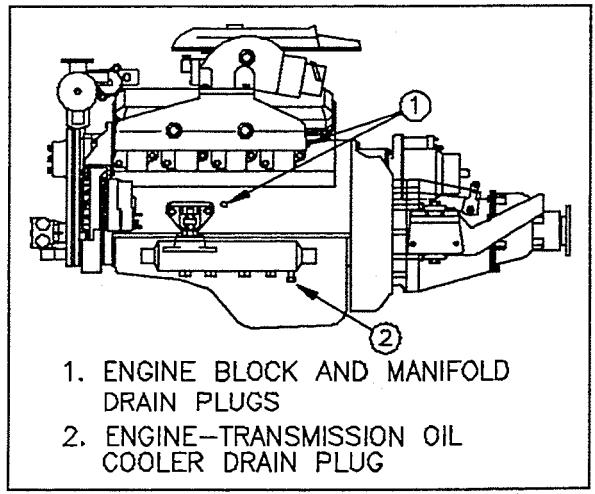
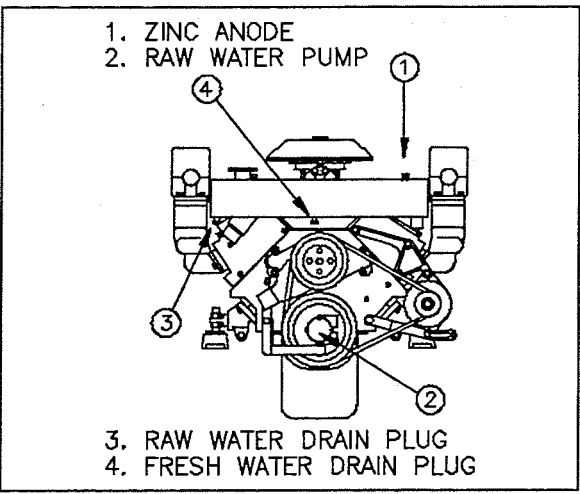
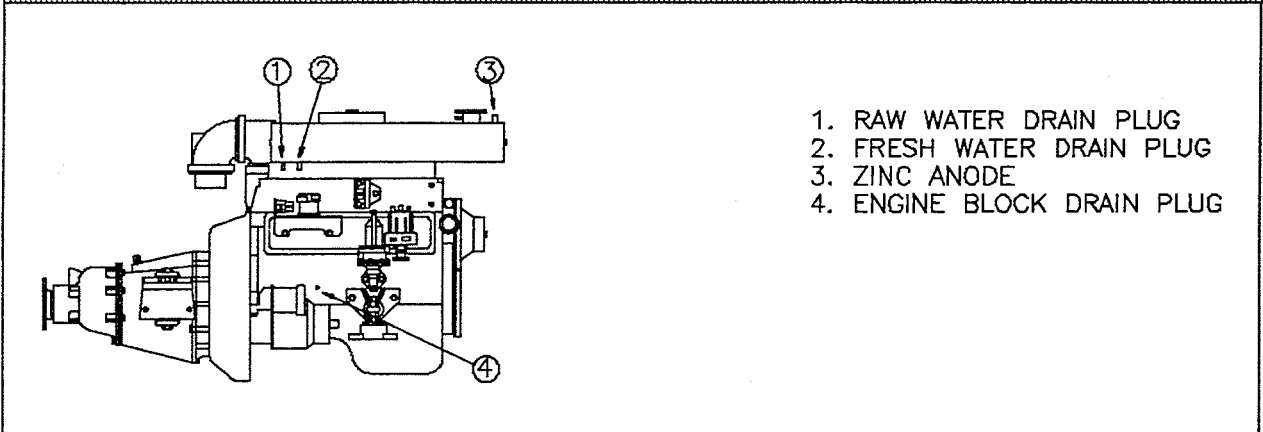

DRAINING COOLING SYSTEM Raw Water Cooling

WARNING: Before draining cooling system, allow engine to cool. Exercise caution when draining system as water may remain hot for an extended period of time in the internal water jackets of the engine.

NOTE: Place an appropriate container under the drain points to collect coolant. This minimizes accumulation of water in the bilge. Dispose of excess coolant mixture properly.

Remove or Disconnect:

1. Water drain plug from engine/transmission oil cooler.
2. Four bolts from raw water pump front cover and remove cover.
3. Exhaust manifold drain plugs from the aft end of each manifold and from engine block. On the 181/250 CID manifold, drain plugs are on the bottom.
4. Hose from water circulating pump.
5. Thermostat from housing. **NOTE:** Allow water to drain completely from entire system before re-assembly.

Clean or Inspect:

1. Hoses and clamps for signs of cracking, swelling or fatigue. Replace if necessary.
2. Thermostat for deterioration, damaged spring, or scale build-up. Replace if necessary.
3. All drain holes for thread damage or erosion. Chase the threads with the proper pipe thread tap, if necessary.

Install or Connect:

1. Thermostat to housing.
2. Hose to water circulating pump.
3. Exhaust manifold drain plugs into aft end of each manifold and port and starboard side of engine

block. **NOTE:** Coat the threads of the plugs with non-hardening sealer or apply Teflon® tape to insure proper seal.

4. Front cover to raw water pump using the four bolts. **NOTE:** Install a new gasket on the front cover, DO NOT use the old gasket as it will not seal properly.
5. Water drain plug into the engine/transmission oil cooler.

DRAINING COOLING SYSTEM Closed Cooling System

WARNING: Before draining cooling system, allow engine to cool. Exercise caution when draining system as water may remain hot for an extended period of time in the internal water jackets of the engine.

NOTE: Place an appropriate container under the drain points to collect coolant. This minimizes accumulation of water in the bilge. Dispose of excess coolant mixture properly.

Remove or Disconnect:

1. Water drain plug from engine/transmission oil cooler.
2. Four bolts from raw water pump front cover and remove cover.
3. Drain plug from raw water side of heat exchanger.

NOTE: The following steps will drain the fresh water coolant from the system. Keep this coolant separate so that it may be reused if antifreeze/water mixture is reusable. Consult local authorities on the proper methods of disposal of used antifreeze. Careless disposal is an environmental hazard and can bring stiff penalties if discovered.

4. Drain plugs from exhaust manifold(s) on the aft end. On 181/250 CID manifolds, drain plugs are located on the bottom of the manifold.

DRAIN COOLING SYSTEM**Closed Cooling System (Continued)**

5. Drain plugs from the port and starboard side of the engine block.
6. Pressure cap from heat exchanger.
7. Fresh water drain plug from heat exchanger.
8. Zinc anode from heat exchanger.
9. Thermostat from housing on heat exchanger.

Clean or Inspect:

1. Hoses and clamps for signs of cracking, swelling, or fatigue. Replace if necessary.
2. Thermostat for deterioration, damaged spring, or scale build-up. Replace if necessary.
3. All drain holes for thread damage or erosion. Chase the threads with the proper pipe thread tap if necessary.
4. Zinc anode for erosion, replace if necessary. See "Zinc Anode Replacement" section below.

Install or Connect:

1. Thermostat in housing.
2. Zinc anode in heat exchanger. See "Zinc Anode Replacement" section below.
3. Fresh water drain plug in heat exchanger.
4. Drain plugs in port and starboard side of block. *NOTE: Apply a non-hardening thread sealing compound or Teflon® tape to plug threads for proper sealing.*
5. Drain plugs in the exhaust manifolds.
6. Drain plug in raw water side of heat exchanger.
7. Raw water pump front cover and new gasket with four bolts.
8. Drain plug in engine/transmission oil cooler.
9. Pressure cap onto heat exchanger.

ZINC ANODE REPLACEMENT
(Fresh Water Cooled Only)

NOTE: It is recommended that the zinc anode be inspected every 50 hours of engine operation or two weeks, whichever comes first.

Remove or Disconnect:

1. Zinc anode from the top of the heat exchanger.

Clean or Inspect:

1. Zinc anode for erosion. If little or no erosion is visible, tap the anode lightly with a hammer. If the anode disintegrates or flakes apart, it is no longer useful.
2. Unscrew or drill out zinc anode from plug.

Install or Connect:

1. Fresh zinc anode into plug. *NOTE: It is important that no thread sealant be used on the zinc anode or the plug. There must be only metal-to-metal contact between the anode and the plug and the plug to the cooling system for proper protection.*
2. Plug with anode into top of heat exchanger.

FILLING FRESH WATER
COOLING SYSTEM

NOTE: Insure all hoses, clamps, plugs and fittings are installed properly and secure before filling cooling system with antifreeze/water mixture.

1. Fill the cooling system through the heat exchanger filler neck to within one (1) inch of the bottom of filler neck.
2. With the pressure cap removed, run engine at fast idle (1500 RPM). Add coolant to maintain the proper level.
3. When engine has reached operating temperature, fill heat exchanger to bottom of filler neck, install pressure cap and check all hoses, gaskets and fittings for leaks.
4. After operating the boat after refilling system, check coolant level and add if necessary.
5. If equipped with recovery bottle, fill bottle to recommended level.

HEAT EXCHANGER PRESSURE CAP TEST

1. Remove cap from heat exchanger after engine has cooled to ambient temperature.
2. Clean any scale or debris from cap and sealing surfaces.
3. Insure locking tabs on cap are not bent or damaged.
4. Test the pressure cap using pressure cap testing tool J-24460-01. Follow direction which accompany the tester. The cap must relieve pressure at 7 psi and hold its rated pressure for thirty (30) seconds without falling below 5 psi.
5. Replace the cap with a new one if it fails the test.
6. Reinstall the cap on the heat exchanger.

HEAT EXCHANGER PRESSURE CHECK

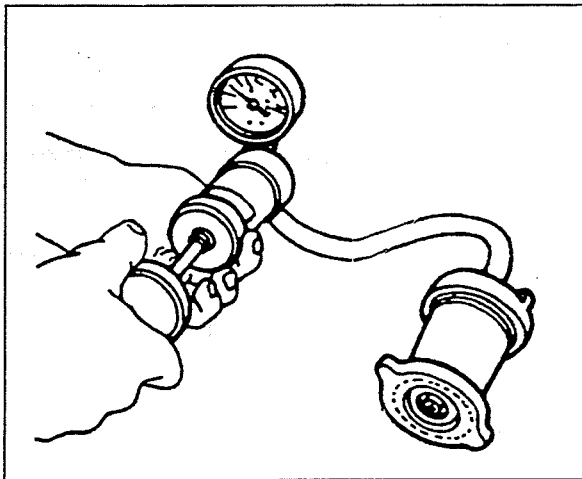

1. Remove pressure cap and install a coolant pressure tester tool J-33419-A.
2. From the heat exchanger, remove a raw water hose going to one of the risers, do not drain the heat exchanger.
3. Pressurize the system to 14 psi.
4. If water begins to flow from the raw water nipple, an internal leak exists and the heat exchanger must be replaced.

PRESSURE CHECKING FRESH WATER COOLING SYSTEM

NOTE: This procedure is recommended if the system is suspected of leaking or failing to hold pressure.

1. Remove pressure cap.
2. Clean filler neck of all scale or debris and insure that the sealing surfaces are smooth.
3. Fill coolant to within one (1) inch of the bottom of filler neck.
4. Attach cooling system pressure tester tool J-33419-A and pressurize system to 14 psi.
5. If the gauge indicates a drop in pressure within two (2) minutes, it can be safely assumed that a leak exists in the system.
6. Visually check all hoses, fittings, drain plugs, pump seals, gaskets for leaks or seepage while maintaining 14 psi on the system. Listen for any bubbling or hissing sounds which may indicate a leak. *NOTE: If pressure drops and no leaks are found, an internal leak(s) should be suspected. Proceed further for diagnosis of internal leaks.*
7. Start the engine and repressurize the system to 14 psi.
8. Observe the pressure gauge for any fluctuations or vibration of the needle. If the needle fluctuates then pressure from the combustion chamber is escaping into the fresh water cooling jackets.
9. To determine which cylinder is leaking, remove spark plug wires one at a time while observing the gauge. When the gauge needle stops fluctuating, the problem cylinder has been located.
10. Remove the spark plug of the suspected cylinder and inspect it to confirm the leak. If the spark plug appears very clean or has a milky film, the leak is in that cylinder.
11. If no leaks appear in the cylinders, drain the oil and check for coolant contamination. The oil will have a milky appearance if coolant is present.
12. Remove oil pan and repressurize the cooling system to 14 psi and inspect the internal surfaces of the engine for leaks or coolant seepage.

**PRESSURE CHECKING FRESH WATER
COOLING SYSTEM (Continued)****FLUSHING RAW WATER
COOLING SYSTEM**

NOTE: Flushing the raw water system is recommended after operation in salt water or water that is heavily polluted or silty.

1. Disconnect raw water inlet hose from the raw water pump. *NOTE: If boat is in the water, shut off the water inlet valve to prevent flooding the boat.*
2. Connect a fresh tap water hose to the pump inlet and turn tap water on approximately half way.
3. Start engine and idle for approximately ten (10) minutes or until the discharged water is clean.

CAUTION! Do not operate the engine above idle as it may require more water than the tap water hose can supply causing the engine to overheat.

4. Stop engine and shut off the tap water supply.
5. Remove the connector from the pump inlet and reconnect the water inlet hose.
6. Insure water inlet valve is open before boat operation.

MECHANICAL PROCEDURES

SECTION 9

GENERAL INFORMATION.....	2
Statement on Cleanliness and Care.....	2
Use of RTV Sealer and Anaerobic Gasket Eliminator	2
Using RTV Sealer.....	2
Using Anaerobic Gasket Eliminator.....	2
Replacing Engine Gaskets.....	3
CYLINDER BORES, PISTONS, RINGS AND CONNECTING RODS.....	3
Cylinder Bore Reconditioning.....	3
Boring.....	4
Honing.....	4
Piston and Connecting Rod Assemblies.....	5
Measuring Piston Pin to Piston Clearance.....	7
Piston Selection.....	7
Assembling the Piston and Connecting Rod.....	8
Installing the Piston Ring.....	9
CAMSHAFT BEARINGS.....	11
Camshaft Bearing Replacement.....	11
CYLINDER HEAD.....	12
Valve Grinding.....	14
Valve Seal Grinding.....	15
Reaming Valve Guides.....	15
MEASURING MAIN BEARING CLEARANCE.....	16
MEASURING CONNECTING ROD BEARING CLEARANCE.....	17
SPECIAL TOOLS.....	19

GENERAL INFORMATION**STATEMENT ON CLEANLINESS AND CARE**

- An engine is a combination of many machined, honed, polished and lapped surfaces with very fine tolerances.
- Whenever valve train components, cylinder head, cylinder, crankshaft or connecting rod components are removed for service, they should be retained in order. At the time of installation, they should be installed in the same locations and with the same mating surfaces as when removed.
- Any time air cleaner, carburetor, or TBI unit is removed, the intake opening must be covered. This will protect against the entrance of foreign material which could follow the intake passage into the cylinder and cause extensive damage when the engine is started.
- When any internal engine parts are serviced, care and cleanliness are important. A liberal coating of engine oil should be applied to friction areas during assembly to protect and lubricate the surfaces on initial operation. Throughout this section, it should be understood that proper cleaning and protection of machined surfaces and friction areas are part of the repair procedure. This is considered standard shop practice even if not specifically stated.

USE OF RTV SEALER AND ANAEROBIC GASKET ELIMINATOR

Two types of sealer are commonly used in engines covered by this manual. These are RTV sealer and anaerobic "gasket eliminator" sealer. It is important that these sealers be applied properly and in the proper place to prevent oil leaks. **THE TWO TYPES OF SEALER ARE NOT INTERCHANGEABLE.** Use the sealer recommended in the procedure.

- RTV (room temperature vulcanizing) sealer is used when a non-rigid part is assembled to a rigid part. Common examples are oil pans and rocker arm covers.
- Anaerobic gasket eliminator hardens in the absence of air. This sealer is used where two rigid parts (such as castings) are assembled together. When two rigid parts

are disassembled and no sealer or gasket is readily noticeable, the parts were probably assembled using gasket eliminator.

USING RTV SEALER

1. Do not use RTV when extreme temperatures are expected, such as exhaust manifold, head gasket or where gasket eliminator is specified.
2. When separating components sealed with RTV, use a rubber mallet and "bump" the part sideways to shear the RTV sealer. "Bumping" should be done at bends or reinforced areas to prevent distortion of parts. RTV is weaker in shear (lateral) strength than in tensile (vertical) strength. *Attempting to pry or pull components apart may result in damage to the part.*
3. Surfaces to be resealed must be clean and dry. Remove all traces of oil and RTV. Clean with a chlorinated solvent such as carburetor spray cleaner. Do not use petroleum cleaners such as mineral spirits; they leave a film onto which RTV will not stick.
4. Apply RTV to one of the clean surfaces. Use a bead size as specified in the procedure. Run the bead to the inside of any bolt holes. Do not allow the sealer in any blind threaded holes, as it may prevent the bolt from seating properly or cause damage when the bolt is tightened.
5. Assemble while RTV is still wet (within 3 minutes). Do not wait for RTV to skin over.
6. Torque bolts to specifications. Do not over-torque.

USING ANAEROBIC GASKET ELIMINATOR

IMPORTANT! Anaerobic sealed joints that are partially torqued and allowed to cure more than five minutes may result in incorrect shimming of the joint.

1. Clean surfaces to be resealed with a chlorinated solvent to remove all oil, grease and old material.
2. Apply a continuous bead of gasket eliminator to one flange.
3. Spread bead evenly with your finger to get a uniform coating on the complete flange.

USING ANAEROBIC GASKET ELIMINATOR (Continued)

- Assemble parts in the normal manner and torque immediately to specifications.

REPLACING ENGINE GASKETS

CAUTION: Composite type gaskets are used in some areas of the engine assembly. These gaskets have a thin metal core. Use caution when removing or handling composite gaskets to help avoid personal injury.

CYLINDER BORES, PISTONS, RINGS AND CONNECTING RODS

MEASURING CYLINDER BORE TAPER AND OUT-OF-ROUND

Tool required:

J-8087 Cylinder Bore Gauge

- If one or more cylinder bores are rough, scored or worn beyond limits, it will be necessary to smooth or true up such bores to fit new pistons.
 - No attempt should be made to cut down oversize pistons to fit cylinder bores as this will destroy the surface treatment and affect the weight. The smallest possible oversize service pistons should be used and the cylinder bores should be honed to size for proper clearances.
- Refer to "Specifications" in the proper section for tolerances.
 - Set the gauge so that the thrust pin must be forced in about 7 mm (1/4") to enter the gauge in the cylinder bore.
 - Center the gauge in the cylinder and turn the dial to "0".
 - Carefully work the gauge up and down the cylinder to determine taper and turn it to different points around the cylinder wall to determine the out-of-round condition (figure 1). Measure the

bore both parallel to and at right angles to the engine centerline. Measure at the top, middle and bottom of the bore and note the readings.

- Recondition the cylinder bore as necessary, as outlined later.

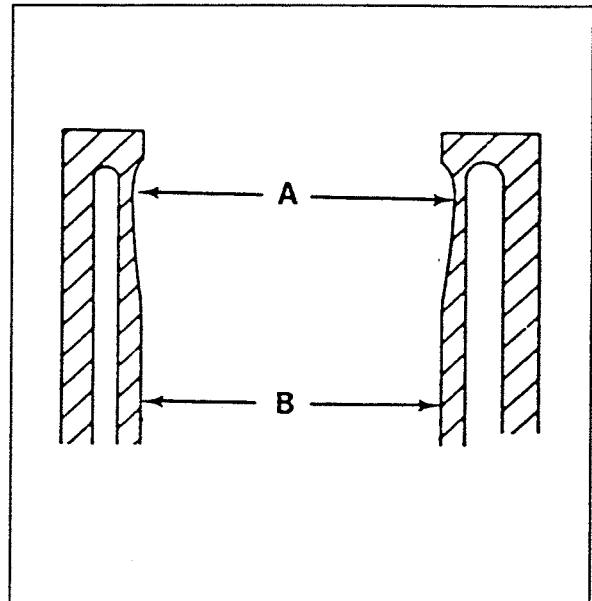

Typical Wear Pattern

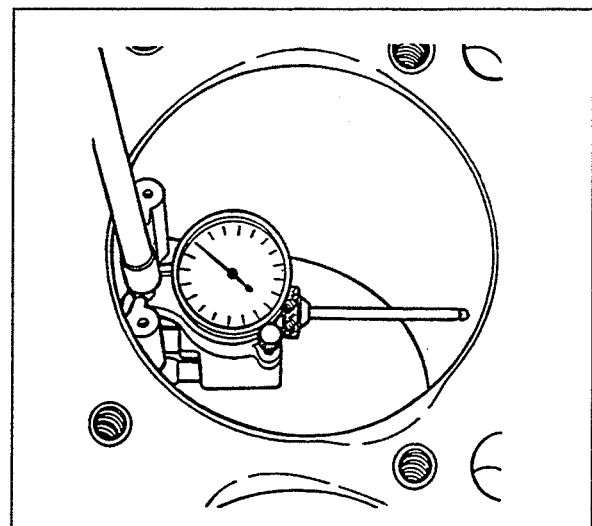

Checking the Cylinder Bore

CYLINDER BORE RECONDITIONING

- Measure the cylinder bore for out of round and taper as outlined previously.

CYLINDER BORE RECONDITIONING (Continued)

2. Measure wear at the top of the bore (point "A") and at the bottom (point "B"). Cylinder bores can be measured by setting the cylinder gauge dial at zero in the cylinder at the point of desired measurement. Lock the dial indicator at zero before removing from the cylinder, and measure across the gauge contact points with outside micrometer, with the gauge at the same zero setting when removed from the cylinder.
3. If the cylinders are found to exceed the specified out-of-round or taper, honing or boring will be necessary. Any cylinders that were found to have less than 0.13mm (0.005 inch) wear or taper may not entirely clean up when fitted to a high limit piston. If it is desired to entirely clean up the bore in these cases, it will be necessary to re bore for an oversize piston. If more than 0.13 mm (0.005 inch) taper or wear, they should be bored and honed to the smallest oversize that will permit complete resurfacing of all cylinders.
4. Fine vertical scratches made by ring ends will not by themselves, cause excessive oil consumption; therefore, honing to remove them is unnecessary.
5. If the bore is glazed but otherwise serviceable, break the glaze lightly with a hone and replace the piston rings. Make sure the honing stones are clean, sharp and straight. Move the hone slowly up and down to produce a 45 to 65 degree cross-hatch pattern. Clean the bore thoroughly with soap and water. Dry and rub in clean engine oil, then remeasure.
6. If honing is not required, the cylinder bores should be cleaned with a hot water and detergent wash. Apply clean engine oil to the bore after cleaning.

BORING

1. Before the honing or reboring operation is started, measure all new pistons with the micrometer contacting at points exactly 90 degrees from the piston pin centerline. Some pistons must be measured at a specified distance from the piston crown. Refer to the proper section for additional instructions. Then select the smallest piston for the first fitting. The slight variation usually found between pistons in a set

may provide for correction in case the first piston is fitted too freely.

2. Before using any type of boring bar, the top of the cylinder block should be filed to remove any dirt or burrs. This is very important. If not checked, the boringbar may be tilted with would result in the rebored cylinder wall not being at right angles to the crankshaft.
3. The instructions furnished by the manufacturer of the equipment being used should be carefully followed.
4. When reboring cylinders, all crankshaft bearing caps must be in place and tightened to the proper torque to avoid distortion of bores in the final assembly. Always be sure the crankshaft is out of the way of the boring cutter when boring each cylinder. Crankshaft bearings and other internal parts must be covered or taped to protect them during the boring or honing operation.
5. When taking the final cut with a boring bar, leave 0.003 mm (0.001 inch) on the diameter for finish honing to give the required position to the cylinder clearance specifications. (The honing or boring operation must be done carefully so that the specified clearance between pistons, rings and cylinder bores is maintained.)

IMPORTANT! Refer to the proper section for additional information.

HONING

1. When the cylinders are to be honed, follow the hone manufacturer's recommendations for the use of the hone and cleaning and lubrication during honing. Use only clean, sharp stones of the proper grade for the amount of material to be removed. Dull, dirty stones cut unevenly and generate excessive heat. When using coarse or medium grade stones use care to leave sufficient metal so that all stone marks may be removed with the fines stones used for finishing to provide proper clearance.
2. Occasionally during the honing operation, the cylinder bore should be thoroughly cleaned and the piston selected for the individual cylinder check for correct fit.

HONING (Continued)

- When honing to eliminate taper in the cylinder, full strokes of the hone in the cylinder should be made in addition to checking measurement at the top, middle and bottom of the bore repeatedly.

NOTICE: Handle the pistons with care and do not attempt to force them through the cylinder until the cylinder has been honed to the correct size as the piston can be distorted through careless handling.

- When finish honing a cylinder bore to fit a piston, the hone should be moved up and down at a sufficient speed to obtain very fine uniform surface finish marks in a cross-hatch pattern of 45 to 65 degrees angle.
- The finish marks should be clean but not sharp, free from imbedded particles and torn or folded metal.
- By measuring the piston to be installed at the sizing point specified in the proper section, and adding the average of the clearance specification, the finish hone cylinder measurement can be determined. It is important that both the block and piston be measured at normal room temperature.
- It is of the greatest importance that refinished cylinder bores are trued up to have the less than specified out-of-round or taper. Each bore must be final honed to remove all stone or cutter marks and provide a smooth surface.
- Refer to "Specifications" in the proper section for piston to bore clearance tolerances.
- After final honing and before the piston is checked for fit, clean the bores with hot water and detergent. Scrub with a stiff bristle brush and rinse thoroughly with hot water. It is essential that a good cleaning operation be performed. If any of the abrasive material is allowed to remain in the cylinder bores, it will wear the new rings and cylinder bores in addition to the bearings lubricated by the contaminated oil. After washing, the dry bore should then be brushed clean with a power-driven fiber brush.
- Permanently mark the piston for the cylinder to which it has been fitted.

- Apply clean engine oil to each bore to prevent rusting.

PISTON AND CONNECTING ROD ASSEMBLIES**DISASSEMBLY****Remove or Disconnect:**

Tools Required:

J-25220 Ring Expander
J-24086-B Piston Pin Remover & Installer

- Piston rings. Use J-25220. In most cases the rings should be discarded and replaced with new ones at assembly.

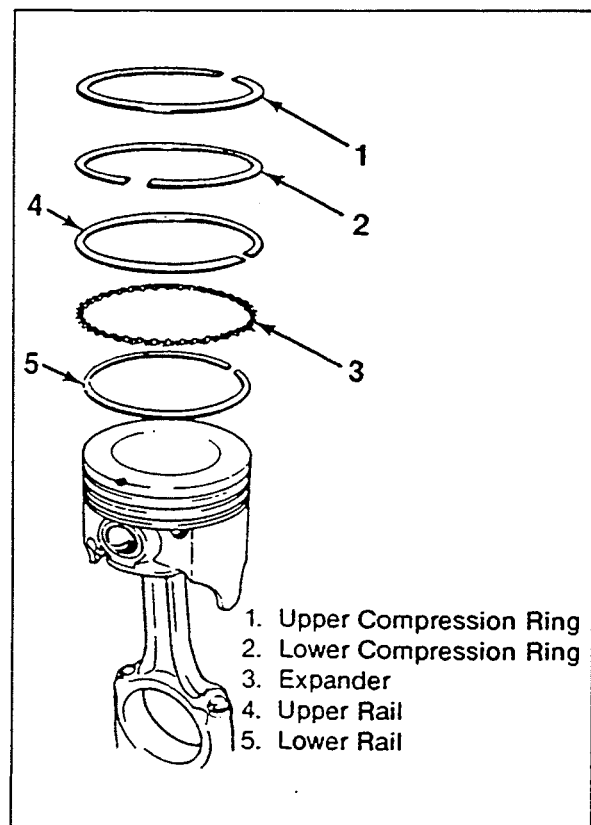

Piston Rings

- Connecting rod bearing inserts. If the inserts are to be reused, place them in a rack so they may be reinstalled in their original connecting rod and cap.

PISTON AND CONNECTING ROD ASSEMBLIES
(Continued)

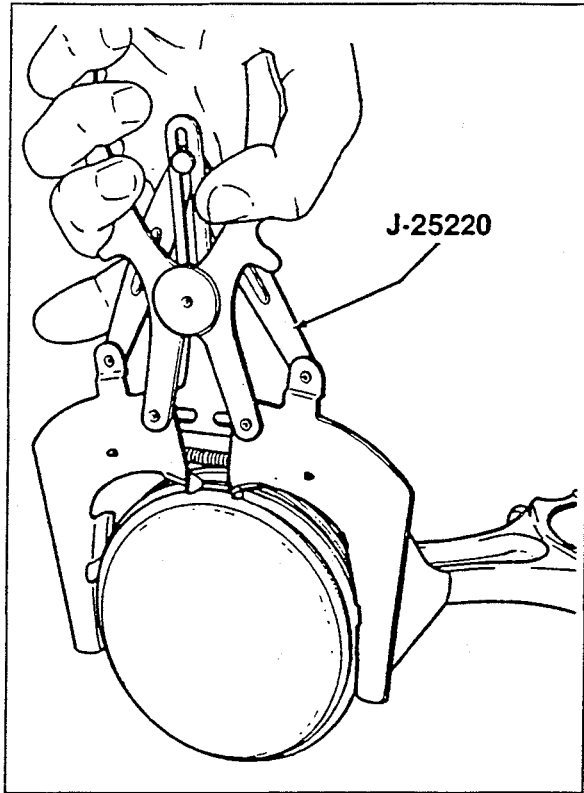

Removing the Piston Rings

3. Piston pin.
 - Place the piston/connecting rod on support fixture J-24086-B. Make sure the connecting rod is fully supported.
 - Place remover J-24086-B on the support fixture.
 - Press out the piston pin.

CLEANING AND INSPECTION

Clean:

- Piston.
 - Remove all varnish and carbon deposits. **DO NOT USE A WIRE BRUSH.**
 - Remove the carbon from the ring grooves. Use a ring groove cleaning tool.
 - Oil control ring groove holes.

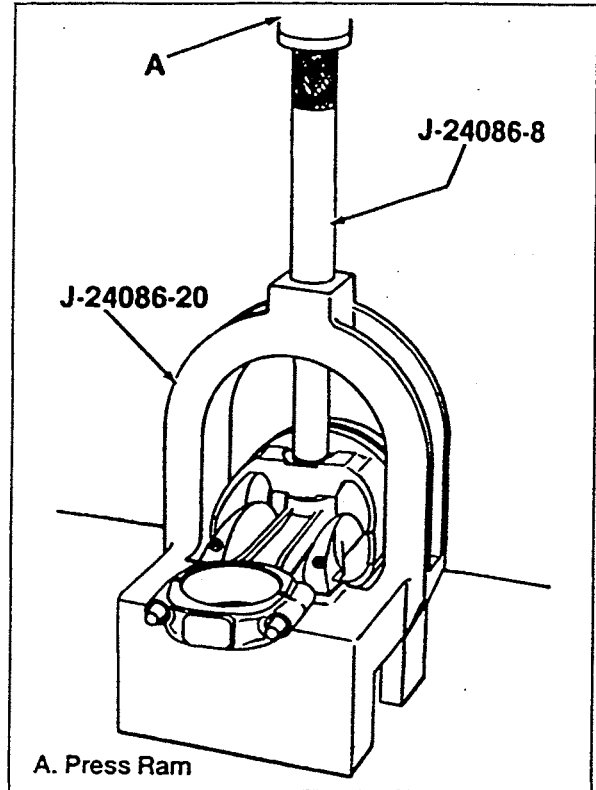

A. Press Ram

Removing the Piston Pin

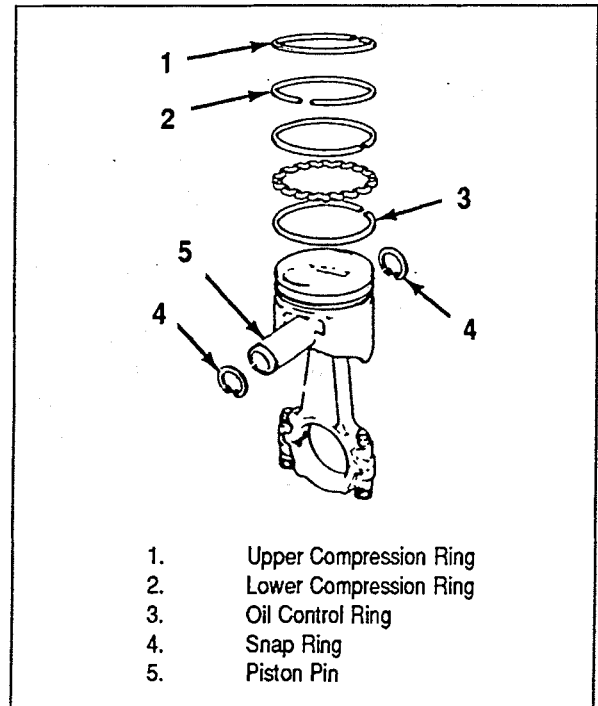

Piston and Components

1. Upper Compression Ring
2. Lower Compression Ring
3. Oil Control Ring
4. Snap Ring
5. Piston Pin

PISTON AND CONNECTING ROD ASSEMBLIES (Continued)

Inspect:

- Piston pin bore in the piston and connecting rod. Check for scuffing, burrs, etc.
- Piston for scratches, wear, etc.
- Connecting rod for cracks, nicks, etc. If a suitable jig is available, check the connecting rod for a bent or twisted condition.
- Piston.
 - Ring land for cracking, wear, etc.
 - Ring grooves for burrs, nicks, etc.
 - Skirts and pin bosses for cracking.
 - Skirts for scuffing.
- Connecting rod bearing inserts for scratches or deep pitting.

MEASURING PISTON PIN TO PISTON CLEARANCE

Measure:

1. Piston pin diameter. Check against "Specifications".
2. Piston pin to piston clearance.
 - Measure the piston pin hole diameter.

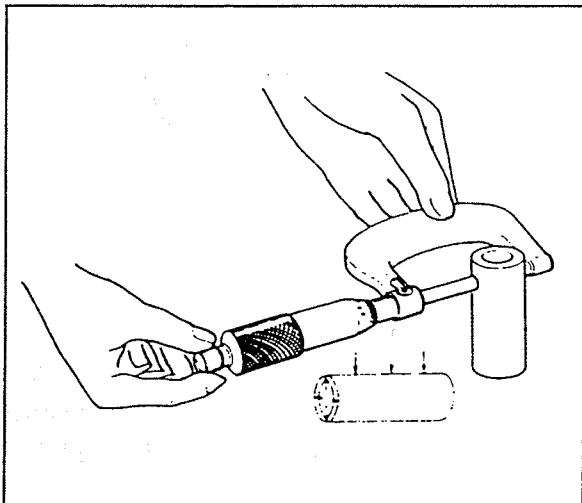

Measuring Piston Pin Diameter

- Subtract the piston pin diameter from the piston pin hole diameter to obtain the clearance.

- Replace the piston and piston pin if the clearance exceeds specifications. The piston and piston pin are a matched set and are not available separately.

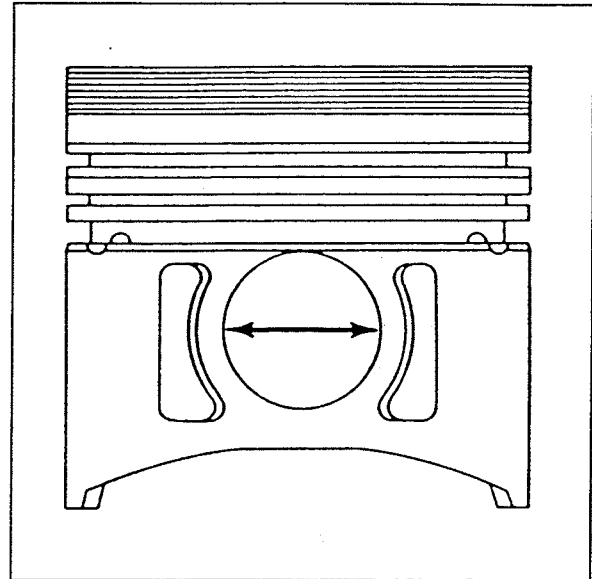

Piston Pin Hole Diameter

PISTON SELECTION

1. Check the used piston to cylinder bore clearance.

Measure:

- Cylinder bore diameter. Use a telescoping bore gauge, located 65 mm (2½") below the top of the cylinder bore.
 - Piston diameter. Measure the piston skirt at a right angle to the piston pin, at the centerline of the piston pin.
 - Subtract the piston diameter from the cylinder bore diameter to determine piston to bore clearance.
 - Refer to "Specifications" in the proper section. Determine if the piston clearance is in the acceptable range.
2. If the used piston is not acceptable, determine if a new piston can fit the cylinder bore.
 3. If a new piston does not bring the clearance within tolerances, the cylinder bore must be reconditioned.

PISTON SELECTION (Continued)

4. Mark the piston to identify the cylinder for which it was fitted.

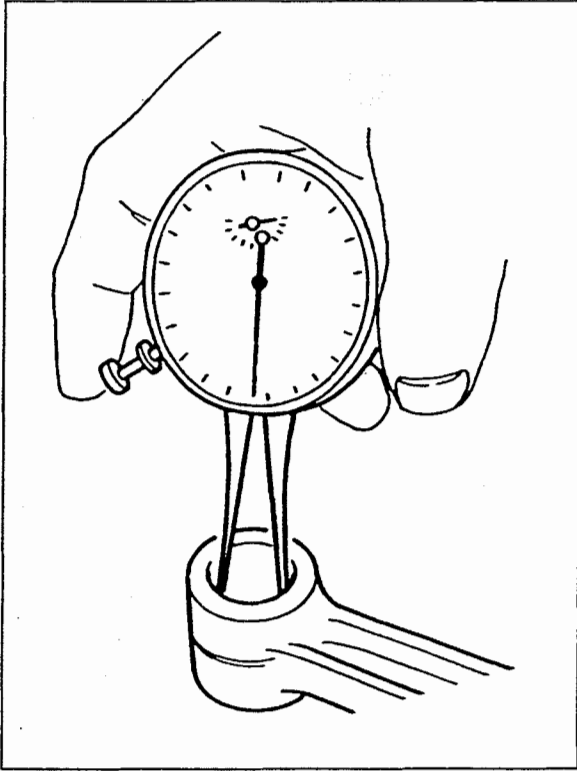
**Measuring Piston Pin Bushing Inside Diameter****ASSEMBLING THE PISTON AND CONNECTING ROD**

Assemble:

Tool required:

J-24086-B Piston Pin Remover and Installer Set

1. Piston and connecting rod.
 - The piston and connecting rod must be installed in the proper position.
 - 3.0L Engines: The raised notch side of the connecting rod must be opposite the notch in the piston crown.
 - All Others: The valve cutouts in the piston crown must be opposite the connecting rod bearing tangs.

- Lubricate the piston pin holes in the piston and connecting rod with engine oil.
- Install the pin guide to hold the piston and connecting rod together. Be sure to use the proper pin guide. Refer to the instructions supplied with the tool.

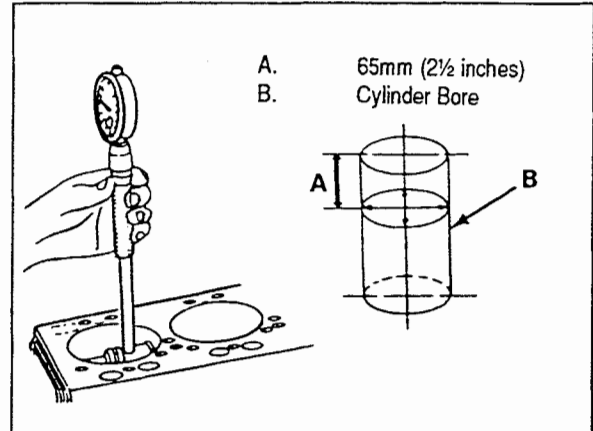
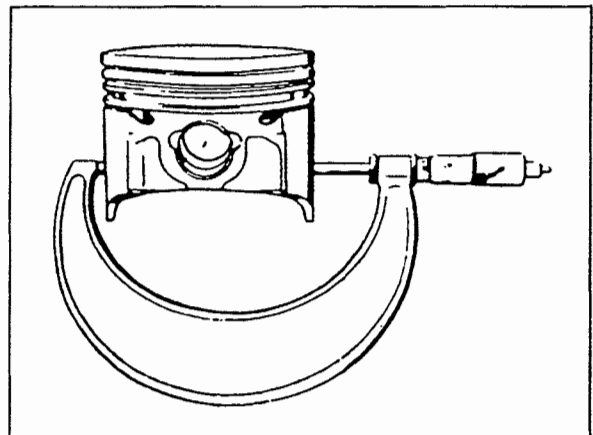
**Measuring Cylinder Bore Diameter****Measuring the Piston Skirt**

2. Piston Pin.
 - Insert the piston pin into the piston pin hole.
 - Place the assembly on the support fixture.
 - Adjust the piston pin installer (J-24086-B) to the correct length, using the letter-number scale on the installer adjuster. This is necessary to insure that the piston pin is pressed into the piston to the correct depth. Refer to the instructions supplied with the tool for the proper setting.
 - Lock the adjuster in place with the lock ring.

ASSEMBLING THE PISTON AND CONNECTING ROD (Continued)

NOTICE: After the installer hub bottoms on the support assembly, do not exceed 35,000 kPa (5000 psi) pressure, as this could cause damage to the tool.

- Place the adjuster in the support fixture. Press the piston pin into place (until the adjustable installer bottoms in the support fixture).
- Remove the piston and connecting rod assembly from the tool and check the piston for freedom of movement on the piston pin.

INSTALLING THE PISTON RINGS

Measure:

- Ring end gap as follows:
 1. Select rings comparable in size to the piston being used.
 2. Slip the compressing ring in the cylinder bore; then press the ring down into the cylinder bore about 7 mm (1/4") above ring travel. Be sure the ring is square with the cylinder wall.
 3. Measure the space or gap between the ends of the ring with a feeler gauge.
 4. Refer to "Specifications" in the proper section for correct gap.
 5. If the gap between the ends of the ring is not as specified, remove the ring and try another for fit.

Inspect:

- Ring fit as follows:
 1. Fit each compression ring to the piston on which it is going to be used.
 2. Slip the outer surface of the top and second compression ring into the respective piston ring groove, to make sure that the ring is free. If binding occurs at any point, the cause should be determined. If binding is caused by the ring groove, correct by depressing the groove with a fine cut file. If the binding

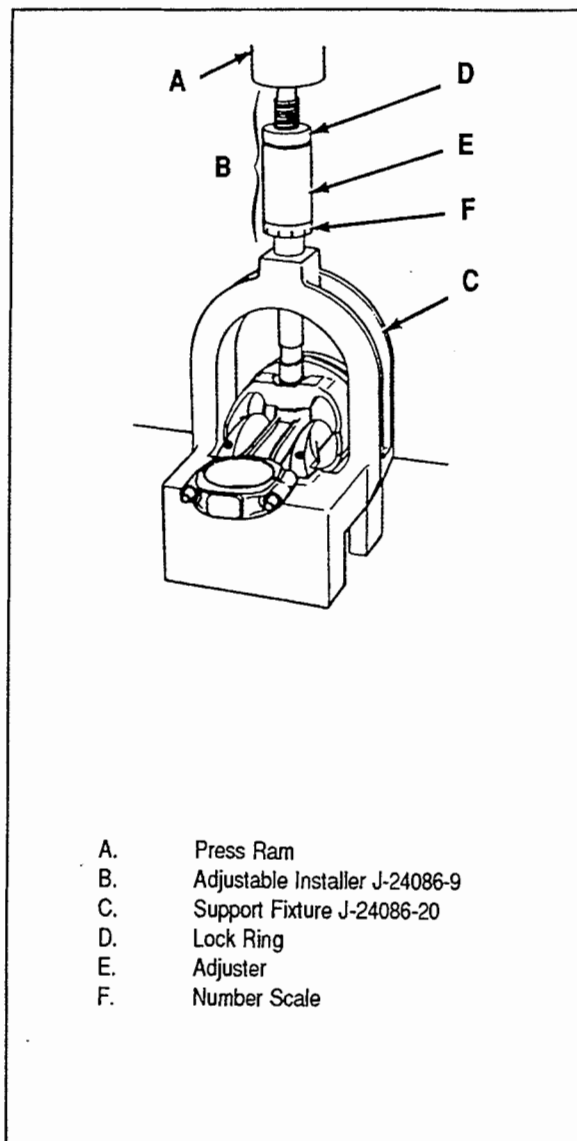

Installing the Piston Pin

is caused by a distorted ring, check a new ring.

Assemble:

Tool required:
J-25220 Ring Expander

- All compression rings are marked on the upper side of the ring. When installing the compression rings, make sure the MARKED SIDE IS TOWARD THE TOP OF THE PISTON.

INSTALLING THE PISTON RINGS (Continued)

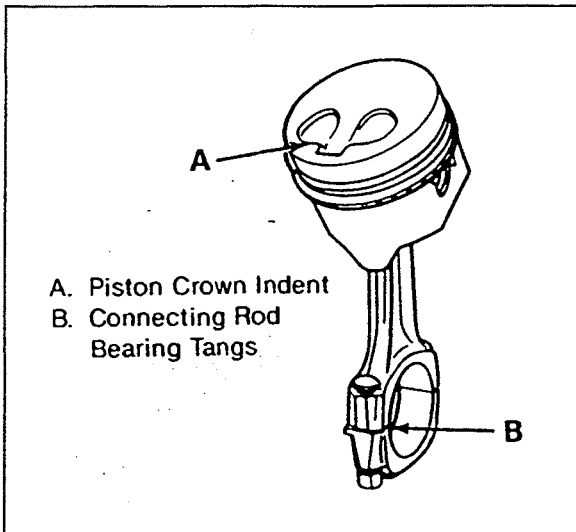
**Aligning the Piston and Connecting Rod**

- The oil control rings are three piece types, consisting of two rails and an expander.

1. Expander.
2. Lower rail.
3. Upper rail.

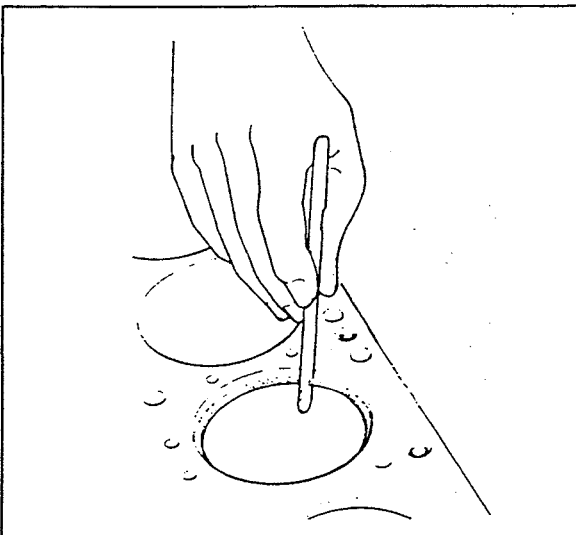
**Measuring Ring End Gap**

4. Upper compression ring. Use J-25220.
5. Lower compression ring. Use J-25220. Flex all rings to make sure the rings are free. If binding occurs at any point the cause should be

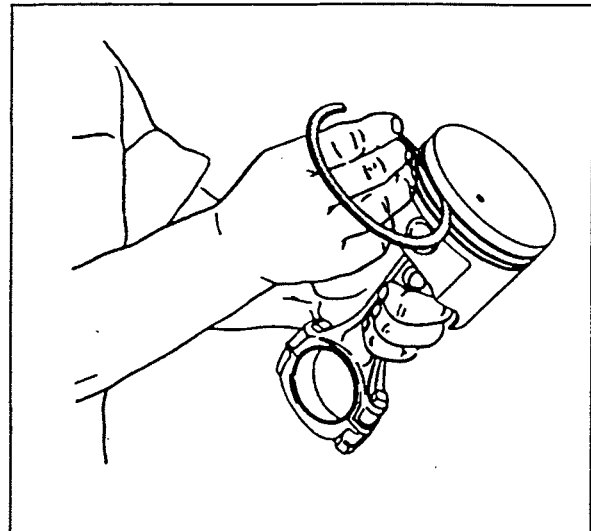
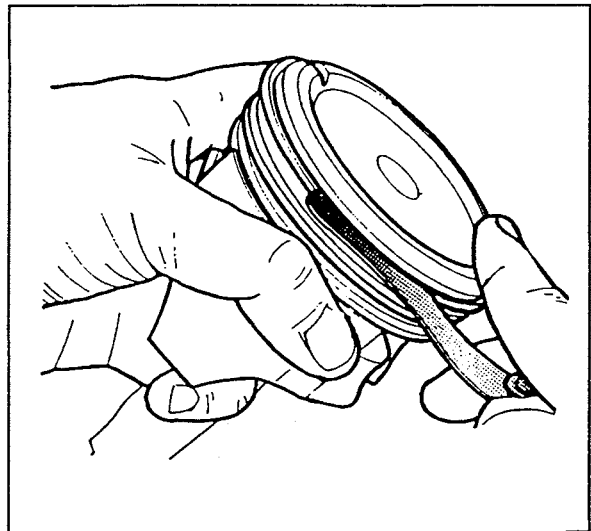
**Checking Ring Fit****Measuring Ring Clearance**

determined. If binding is caused by the ring groove, correct by dressing the groove with a finecut file. If binding is caused by a distorted ring, check a new ring.

Measure:

- Ring clearance. Use a feeler gauge as shown. Compare with "Specifications" in the proper section.

CAMSHAFT BEARINGS

CAMSHAFT BEARING REPLACEMENT

Inspect:

- Camshaft bearings for scratches, pits or loose fit in their bores. Replace the camshaft bearings if necessary.

Disassemble:

Tool required:

J-6098-01 Camshaft Bearing
Remover/Installer

1. Rear camshaft plug or cap.
2. Inner camshaft bearings. Use J-6098-01.
 - Insert the pilot into the front camshaft bearing bore.
 - Slide the puller screw, with the nut and washer, through the pilot.
 - Insert the bearing tool into the inner camshaft bearing bore, with the shoulder of the tool against the bearing.
 - Hold the puller screw with a wrench. Turn the nut with a second wrench to pull the camshaft bearing from its bore.
 - Repeat this procedure to remove the remaining inner camshaft bearings. Note that the rear inner bearing must be removed with the pilot fitted into the rear camshaft bearing.
3. Outer camshaft bearing. Use J-6098-01.
 - Assemble the bearing tool and driver handle.
 - Drive the outer camshaft bearings out of the block.

Clean:

- Camshaft bearing bores in the block.

Assemble:

Tool required:

J-6098-01 Camshaft Bearing
Remover/Installer

- The outer camshaft bearings must be installed first. These bearings serve as guides for the pilot, and help center the inner bearings during the installation process.

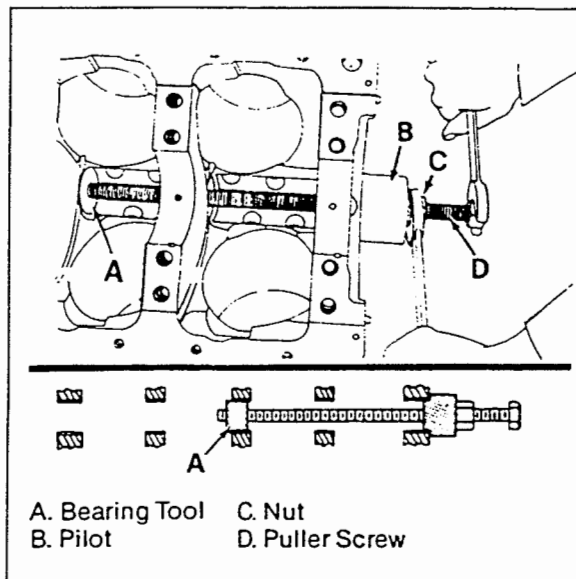

**Removing or Installing the Inner
Camshaft Bearings**

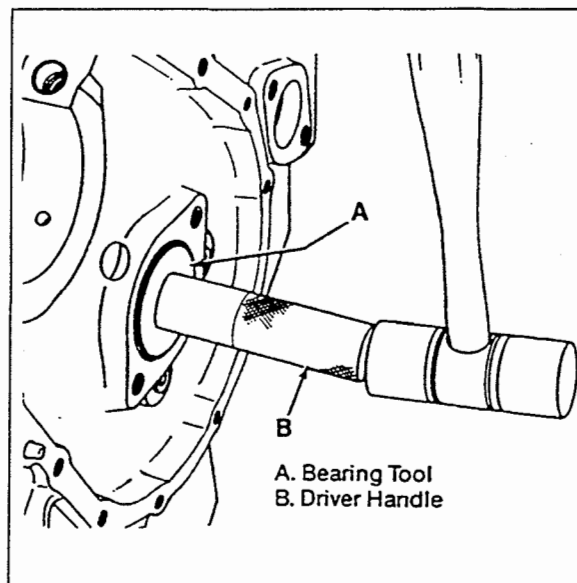

**Removing or Installing the Outer
Camshaft Bearings**

- Be sure to fit the correct cam bearing into the bore. The cam bearing bores vary in size.

CAM BEARING REPLACEMENT (Continued)

1. Outer camshaft bearings. Drive the bearings into place using J-6098-01.

IMPORTANT: Make sure the camshaft bearing hole (or holes) align with the oil hole (or holes) in the block. On some engines, the oil holes may be difficult to see. If so, use a piece of 2 mm (3/32") rod as shown to check alignment.

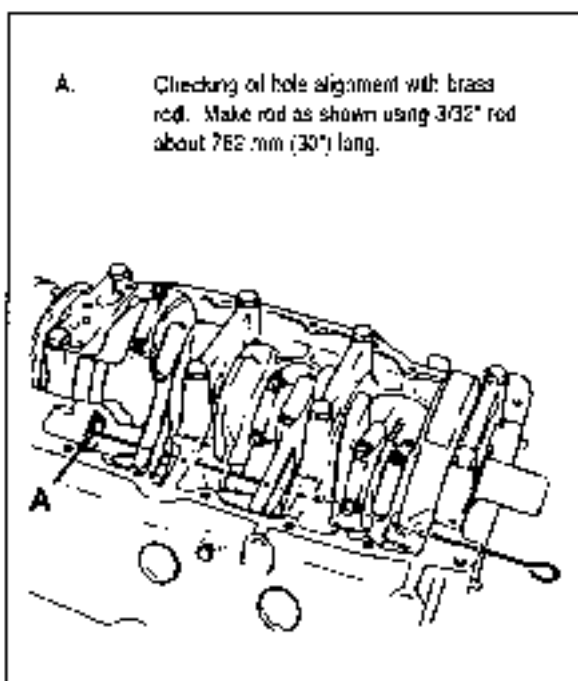

- A. Checking oil hole alignment with brass rod. Make rod as shown using 3/32" rod about 762 mm (30") long.

Checking Camshaft Bearing Oil Hole Alignment (Typical)

2. Inner camshaft bearing. Use tool J-6098-01.
 - Assemble the tool with the pilot engaged in the front bearing and the pilot flange against the front face of the block.
 - Slide the puller screw, with nut and washer, through the pilot.
 - Place the new bearing on the bearing tool. Hold the bearing tool and bearing against the bearing bore. Align the bearing oil hole with the oil hole in the block.
 - Thread the puller screw into the bearing tool enough to hold the tool and bearing in place.

- Holding the puller screw with a wrench, turn the nut with a second wrench to pull the camshaft bearing into place.
- Remove the puller screw, pilot and bearing tool.

IMPORTANT! Make sure the camshaft bearing hole (or holes) align with the oil hole (or holes) in the block. If it is difficult to see the alignment, use a piece of brass rod as described in step #1.

3. Camshaft rear plug or cap.
 - Coat a new camshaft plug with sealer (Loctite #592 or equivalent).
 - Install the plug flush to 0.80 mm (1/32") deep.

CYLINDER HEAD

CYLINDER HEAD DISASSEMBLY

Disassemble:

- Valves and components. Refer to proper section.

CLEANING AND INSPECTION

Clean:

Tools required:

- J-8089 Wire Brush
- J-8101 Valve Guide Cleaning Tool

- Carbon from the combustion chambers. Use J-8089.
- Valve guides. Use J-8101.
- Valve stems and heads on a wire wheel.
- Carbon and old gasket from the cylinder head gasket surface.

Inspect:

- Cylinder head for cracks in the exhaust ports, combustion chambers, or external cracks to

CYLINDER HEAD (Continued)

the coolant chamber. Gasket surfaces should be free of damage.

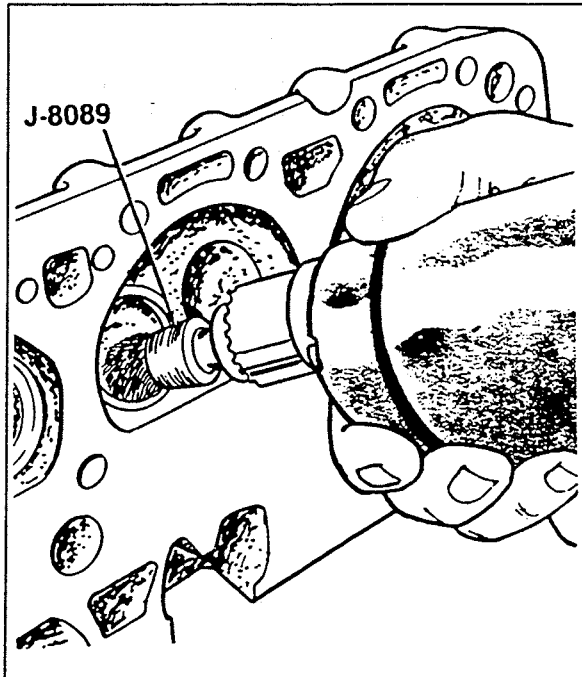

Cleaning the Combustion Chambers (Typical)

- Valves for burning, pitting or warpage. Grind or replace as needed. Refer to "Valve Grinding". Check the valve stems for scoring or excessive wear. Stems must not be bent.
- Rocker arm studs (if used) for wear, damage or improper fit.
- Valve seats for pitting or other damage. Grind or reface as needed.
- Rotators (if used). The rotators should rotate smoothly, without bind.

Measure:**Tools required:**

- J-8520 Dial Indicator
- J-9666 Valve Spring Tester

- Valve stem to guide bore clearance.
- Excessive valve stem to guide bore clearance will cause excessive oil consumption and may cause valve breakage. Insufficient clearance

will result in noisy and sticky functioning of the valve and disturb engines smoothness.

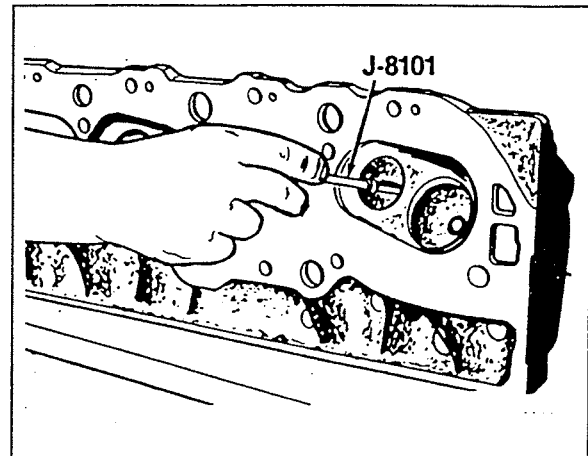

Cleaning the Valve Guides (Typical)

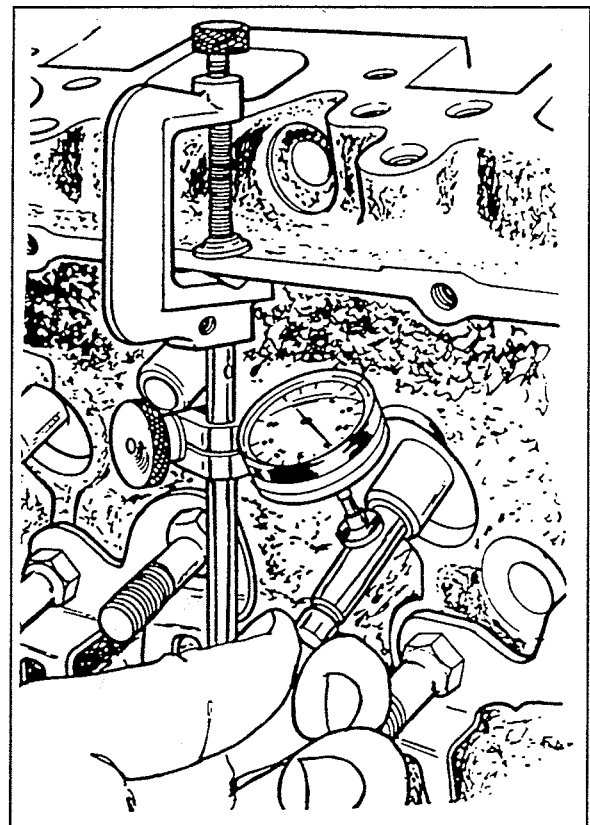

Measuring Stem to Bore Clearance (Typical)

- Clamp a Dial Indicator J-8520 on one side of the cylinder head rocker arm cover gasket rail.

CYLINDER HEAD (Continued)

- Locate the indicator so that movement of the valve stem from side to side (crosswise to the head) will cause a direct movement of the indicator stem. The indicator stem must contact the side of the valve stem just above the valve guide bore.

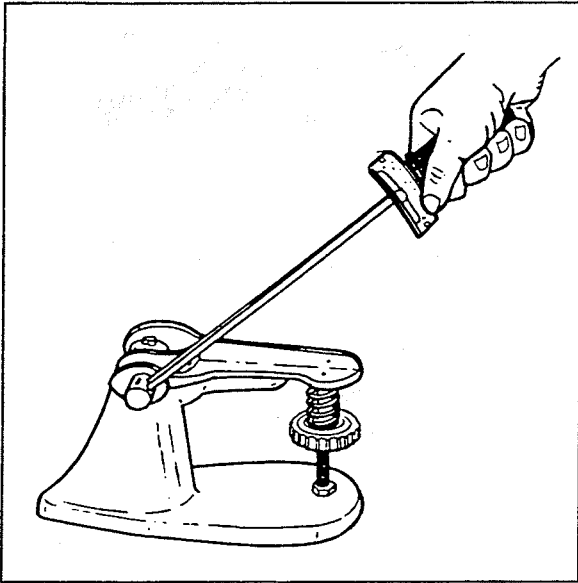
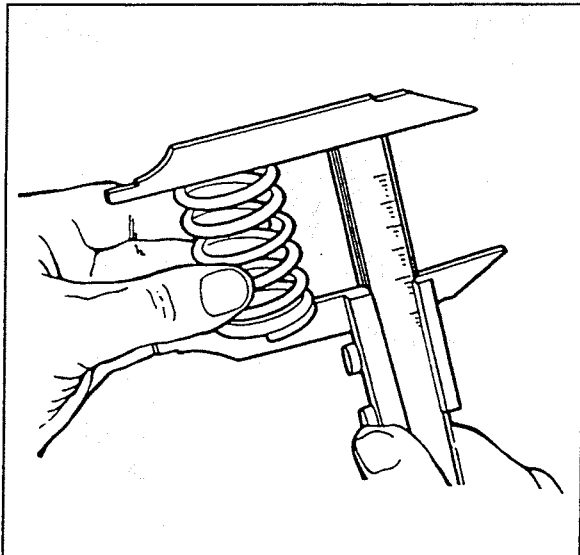
**Measuring Valve Spring Tension****Measuring Valve Spring Length**

- Drop the valve head about 1.6 mm (1/16") off the valve seat.

- Move the stem of the valve from side to side using light pressure to obtain a clearance reading. If clearance exceeds specifications, it will be necessary to ream valve guide bores for oversize valves as outlined later in this manual.
 - Valve spring tension. Use J-9666.
- Compress the springs, with dampers removed, to the specified height and check against the specifications chart. Springs should be replaced if not within 44 N•m (10 lbs.) of the specified load.
 - Valve spring length. Replace the spring if the length is not as specified.

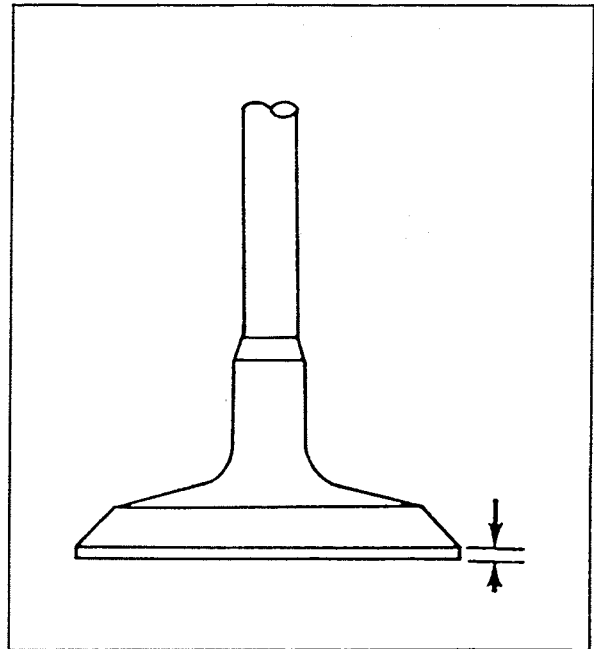
**Valve Head Measurement****CYLINDER HEAD REPAIR****VALVE GRINDING**

Valves that are pitted must be refaced to the proper angle. Valve stems which show excessive wear, or valves that are warped excessively must be replaced. When a valve head which is warped excessively is refaced, a knife edge will be ground on part of all of the valve head due to the amount of metal that must be removed to completely reface. Knife edges lead to breakage, burning or preignition due to heat localizing

CYLINDER HEAD REPAIR (Continued)

on this knife edge. If the edge of the valve head is less than 0.80 mm (1/32") after grinding, replace the valve.

Several different types of equipment are available for refacing valves. The recommendation of the manufacturer of the equipment being used should be carefully followed to attain proper results.

Refer to "Specifications" in the proper section for valve face angle specifications.

VALVE SEAT GRINDING

Reconditioning the valve seats is very important, because the seating of the valves must be perfect for the engine to deliver the power and performance built into it.

Another important factor is the cooling of the valve head. Good contact between each valve and its seat will insure that heat will be properly carried away.

Several different types of equipment are available for reseating valve seats. The recommendations of the manufacturer of the equipment being used should be carefully followed to attain proper results.

Regardless of what type of equipment is used, however, it is essential that valve guide bores be free from carbon or dirt to ensure proper centering of the pilot in the guide. Refer to "Specifications" in the proper section for valve seat angle specifications.

NOTICE: Excessive removal of stock may result in damage to the valve seats.

REAMING VALVE GUIDES

The valve guides used in engines covered by this manual are simply holes bores into the cylinder head. The valve guides are therefore not replaceable.

If the valve stem to bore clearance as measured previously in this manual is excessive, the valve guides

should be reamed and a valve with an oversize stem installed.

Available oversize valve are as follows. Nominal dimensions are given.

- 4.3L:
 - Intake: 0.008 mm (0.003-inch), 0.38 mm (0.015-inch), 0.76 mm (0.030-inch)
 - Exhaust: 0.08 mm (0.003-inch), 0.38 mm (0.015-inch)

Select a ream which will provide a straight, clean bore through the guide's entire length.

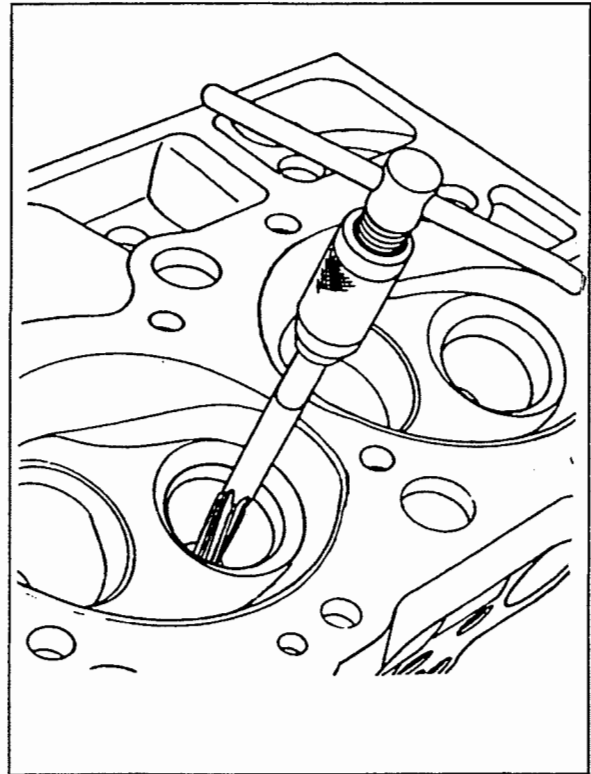

Reaming the Valve Guides (Typical)

Reamer availability is as follows. Sizes given are nominal.

- All engines except 7.4L and 8.2L:
 - 0.08 mm (0.003 inch) oversize.
 - 0.13 mm (0.005 inch) oversize.
 - 0.38 mm (0.015-inch) oversize.
 - 0.76 mm (0.030-inch) oversize.
 - These reamers are available in Reamer Set #J-5830-01.

REAMING VALVES GUIDES (Continued)

- 7.4L and 8.2L engines:
 - 0.008 mm (0.003-inch) oversize.
 - 0.038 mm (0.015-inch) oversize.
 - 0.76 mm (0.030-inch) oversize.
 - These reamers are available in Reamer Set #J-5830-02.

ASSEMBLY**Assemble:**

- Valve and components. Refer to proper section.

MEASURING MAIN BEARING CLEARANCE

Main bearings are of the precision insert type and do not use shims for adjustment. If clearances are found to be excessive, new upper and lower inserts will be required.

The simplest, most accurate way to measure main bearing clearance is with the use of gaging plastic. This wax-like material compresses evenly between the bearing and journal surfaces without damaging them. Proceed as follows:

Clean:

- All oil from the crankshaft journal and main bearing inserts.

Install or Connect:

- Refer to the proper section for additional information.
1. Main bearing inserts and crankshaft, as outlined in the proper section.
 2. Gaging plastic.
 - Begin with the rear main bearing.
 - Wipe the oil from the crankshaft journal and the lower main bearing insert.
 - Place a piece of gaging plastic the full width of the lower bearing insert (parallel to the

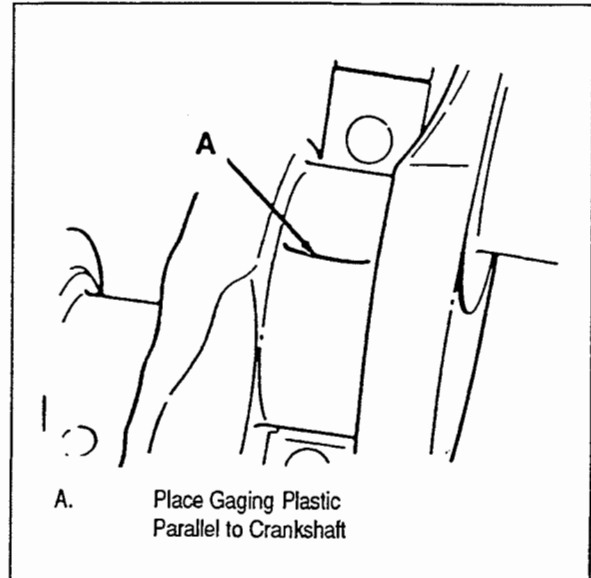

Placing the Gaging Plastic on the Bearing Journal

crankshaft) on the journal. Do not rotate the crankshaft while the gaging plastic is between the bearing and journal.

3. Main bearing cap and bolts.

Tighten:

- Bolts to "Specifications".

Remove or Disconnect:

- Main bearing cap.
DO NOT REMOVE THE GAGING PLASTIC FROM THE JOURNAL OR LOWER MAIN BEARING INSERT.

Measure:

- Gaging plastic as follows:

1. The flattened gaging plastic will be found adhering to either the lower bearing insert or journal.
2. On the edge of the gaging plastic envelope there is a graduated scale. Without removing the gaging plastic, measure its compressed width (at the widest point) with the graduations on the gaging plastic envelope.
3. If the flattened gaging plastic tapers toward the middle or ends, there is a difference in clearance indicating taper, low spot or other irregularity of

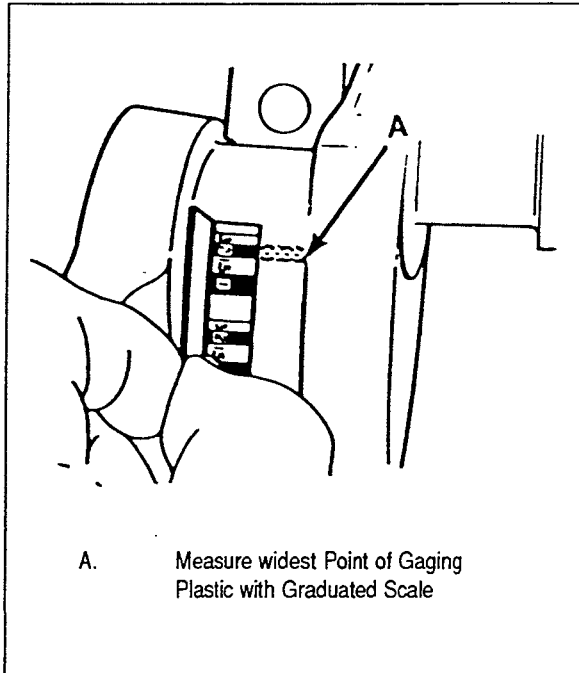

A. Measure widest Point of Gaging Plastic with Graduated Scale

Measuring the Gaging Plastic

- the bearing or journal. Be sure to measure the journal with a micrometer if the flattened gaging plastic indicates more than 0.001 inch difference.
4. Normally main bearing journals wear evenly and are not out-of-round. However, if a bearing is being fitted to an out-of-round journal, be sure to fit to the maximum diameter of the journal. If the bearing is fitted to the minimum diameter and the journal is excessively out-of-round, interference between the bearing and the journal will result in rapid bearing failure.
 5. If the bearing clearance is within specifications, the bearing is satisfactory. If the clearance is not within specifications, replace the bearing. Always replace both upper and lower inserts as a unit.
 6. A standard or undersize bearing may produce the proper clearance. Refer to the proper section for bearing availability. If not, it will be necessary to re-grind the crankshaft journal for use with the next undersize bearing. Do not grind rolled fillet crankshafts, such as used on 3.0L engines. After selecting the new bearing, recheck the clearance.
 7. Remove the flattened gaging plastic.
 8. Perform the preceding steps on the remaining main bearings.

9. The plastic gage should be positioned in the middle of the upper and lower bearing insert. (Bearings are eccentric and false readings could occur if placed elsewhere.)

MEASURING CONNECTING ROD BEARING CLEARANCE

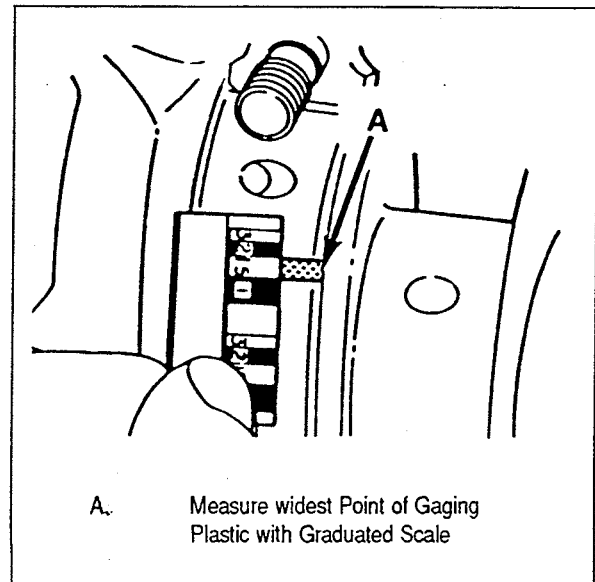

A. Measure widest Point of Gaging Plastic with Graduated Scale

Measuring the Gaging Plastic

IMPORTANT! If a bearing is being fitted to an out-of-round crankpin, be sure to fit the maximum diameter of the crankpin. If the bearing is fitted to the minimum diameter and the crankpin is excessively out-of-round, interference between the bearing and the crankpin will result in rapid bearing failure.

3. Connecting rod cap with the lower connecting rod bearing insert. **DO NOT TURN THE CRANKSHAFT WITH THE GAGING PLASTIC INSTALLED.**
4. Connecting rod cap nuts.

Tighten:

- Nuts to "Specifications". Refer to the proper section.

MEASURING CONNECTING ROD BEARING CLEARANCE (Continued)

Measure:

- Gaging plastic at its widest point, using the scale of the gaging plastic envelope.







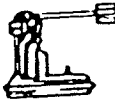

IMPORTANT! The gaging plastic will be found sticking either to the journal or lower connecting rod bearing insert. Do not remove at this time.

- If the clearance exceeds specifications, select a new, correct size, connecting rod bearing and re-measure the clearance.
- A standard or undersize bearing may produce the proper clearance. Refer to the proper section for bearing availability.
- Do not attempt to use shims or file the bearing to obtain the needed clearance.
- If clearance cannot be brought to within specifications, recondition or replace the crankshaft. (Do not recondition a rolled fillet crankshaft, such as used on 3.0L engines.)

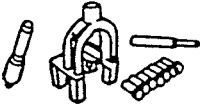
Remove or Disconnect:

- Gaging plastic.

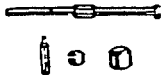
SPECIAL TOOLS

1		J 8087	6		J 5790
2		J 25220	7		J 8089
3		J 24086	8		J 8101
4		J 29134-A	9		J 8001
5		J 6098-01	10		J 8056

1. Cylinder Bore Gage
2. Ring Expander
3. Piston Pin Replacer Set
4. Piston Pin Clip Installer
5. Camshaft Bearing Replacer
6. Hydraulic Lifter Leakdown Tester
7. Wire Brush
8. Valve Guide Cleaning Tool
9. Dial Indicator
10. Valve Spring Tester
11. Intake Opening Cover
12. 0.13 mm (0.005-inch) Oversize Valve Guide Reamer (2.5 L Engines)
13. Valve Guide Reamer Set (All Engines Except 6.2 L and 7.4 L). Consists of:
 - J-5830-1: 0.08 mm (0.003-inch) oversize
 - J-5830-2: 0.38 mm (0.015-inch) oversize
 - J-5830-3: 0.76 mm (0.030-inch) oversize
14. Valve Guide Reamer Set (6.2 L and 7.4 L Engines). Consists of:
 - J-7049-1: 0.08 mm (0.003-inch) oversize
 - J-7049-2: 0.38 mm (0.015-inch) oversize
 - J-7049-3: 0.76 mm (0.030-inch) oversize

11		J 29664
----	--	---------

12		J 6621
13		J 5830-02
14		J 7049

ENGINES: 181/250 CID (3.0-4.1L)

SECTION 10

DESCRIPTION.....	2
ENGINE LUBRICATION.....	2
TOOLS AND SHOP EQUIPMENT.....	2
CLEANING.....	2
INTAKE-EXHAUST MANIFOLD REPLACEMENT.....	3
MANIFOLD RISER REPLACEMENT.....	4
THERMOSTAT HOUSING REMOVAL (FRESH WATER COOLED ENGINES).....	4
THERMOSTAT HOUSING REMOVAL (RAW WATER COOLED ENGINES).....	5
CIRCULATION PUMP REPLACEMENT.....	5
VALVE TRAIN COMPONENT REPLACEMENT.....	6
CYLINDER HEAD REPLACEMENT.....	7
TORSIONAL DAMPER REPLACEMENT.....	10
OIL PAN REPLACEMENT.....	11
OIL PUMP REPLACEMENT.....	11
TIMING GEAR COVER REPLACEMENT.....	13
PISTON AND CONNECTING ROD REPLACEMENT.....	14
FLYWHEEL REPLACEMENT.....	15
CRANKSHAFT REPLACEMENT.....	15
CRANKSHAFT REAR OIL SEAL REPLACEMENT.....	17
ENGINE SPECIFICATIONS CHARTS.....	18
TORQUE SPECIFICATIONS CHARTS.....	20
SPECIAL TOOLS.....	21

DESCRIPTION

The 181 CID (3.0L) engine is an inline four-cylinder engine and the 250 CID (4.1L) engine is an inline six-cylinder engine, both of which have overhead valves, cast iron cylinder blocks and heads.

The 181 CID engine's crankshaft is supported by five (5) main bearings with the thrust taken at the number five (rear) bearing.

The 250 CID engine's crankshaft is supported by seven (7) main bearings with the thrust taken at the number seven (rear) bearing.

Both engine's camshafts are low in the block and are gear driven, i.e., no timing chain is used.

ENGINE LUBRICATION

The oil pump is gear driven from the camshaft. Oil is drawn from the oil pan through a pickup screen and tube. A bypass valve in the pickup screen insures adequate oil flow if the screen becomes restricted. The gear type oil pump has a pressure regulator valve which controls lubrication system pressure by bypassing excess oil back to the oil pan sump.

Pressurized oil from the oil pump flows to the full flow filter. A bypass valve allows oil to bypass the filter if it becomes clogged or restricted. Oil then flows into an oil passage which runs along the right side of the block and intersects the lifter bosses. Oil from this passage is then routed to the crankshaft main bearings and camshaft bearings through smaller drilled passages. Oil is supplied to the connecting rod bearings by holes drilled in the crankshaft. Oil is supplied to the rocker arms through holes in the hydraulic lifters which feel oil up the pushrods to the rocker arms. The oil is metered by discs under the pushrod seat.

Many internal engine parts have no direct oil feed and are supplied by either gravity or splash from other direct feed components. Timing gears are lubricated by oil which is supplied through a passage from the front of the camshaft to a calibrated nozzle above the crankshaft gear.

NOTE: Because of the similarities in the designs of the 181 and 250 engines, this manual will cover both engines. Specific procedures or parameters for each engine will be called out when necessary.

CAUTION! The internal components of an engine have machined surfaces that may have sharp edges. Exercise caution when working with such components and **NEVER** run a hand or fingers along an edge to check for surface imperfections as minor cuts to severe lacerations may occur!

TOOLS AND SHOP EQUIPMENT

A clean, well lit work area should be available. Other necessary aids include: a suitable parts cleaning tank, compressed air supply, trays to keep parts and fasteners organized, and an adequate set of hand tools.

An approved engine repair stand will aid the work and help prevent personal injury or damage to engine components.

Special tools are illustrated throughout this section, and are listed at its end. These tools are specially designed to quickly and safely accomplish the operations for which they are intended. The use of these tools will also minimize possible damage to engine components.

Some precision measuring tools are required for inspection of certain critical components. Torque wrenches will be necessary for correct assembly of various parts.

CLEANING

Remove the engine accessories before cleaning to provide better access to engine exterior surfaces. After removing the carburetor or TBI unit, distributor, fuel pump, oil filter, etc., cover the openings with tape to prevent the entry of water solvent and dirt.

CLEANING (Continued)

Methods used to clean the engine will depend on the aids which are available. Steam cleaning, pressure washing, or solvent cleaning are some acceptable methods.

It is important that the engine be as clean as possible to prevent dirt from entering critical areas during disassembly.

INTAKE-EXHAUST MANIFOLD REPLACEMENT

NOTE: The intake and exhaust manifolds on the 181 CID and 250 CID engines are incorporated into one single unit.

Remove or Disconnect:

1. Battery negative cable
2. Engine coolant (See "Cooling Systems" section in this manual.)
3. For freshwater cooled engines, remove:
 - Fuel pump/filter bracket and fuel lines.
 - Freshwater coolant hose from the exhaust riser.
 - Seawater hose from the exhaust riser downturn.
 - Transmission oil cooler brackets.
4. Crankcase ventilation hose from valve cover.
5. Fuel lines at the carburetor.
6. Alternator wire harness bracket on manifold.
7. Automatic choke wire at the carburetor (the wire coming out of alternator wire harness).
8. Thermostat housing to manifold coolant hose.
9. Throttle linkage from carburetor.
10. Loosen, do not remove, manifold-to-block bolts and bump the engine side of the manifold with a rubber mallet until manifold breaks free from block.
11. Manifold-to-block bolts.
12. Manifold.

13. Cover or plug intake and exhaust ports on the block to keep foreign material out of cylinders.

Clean or Inspect:

1. All gasket material from manifold and block.
2. Engine-to-manifold mating surfaces for nicks or warpage.
3. Coolant hoses for cuts or splits that may have occurred during the removal process and replace if necessary.
4. Threads on manifold bolts.

Install or Replace:

NOTE: Remove any covers or plugs from intake and exhaust ports before installing manifold to block.

1. New manifold gasket with Permatex® sealant or equivalent on both sides to insure proper seal.
2. Manifold-to-block bolts (finger tight). **NOTE:** Position alternator wire harness and bracket at this time.

Tighten:

- Manifold-to-block bolts in the sequence shown

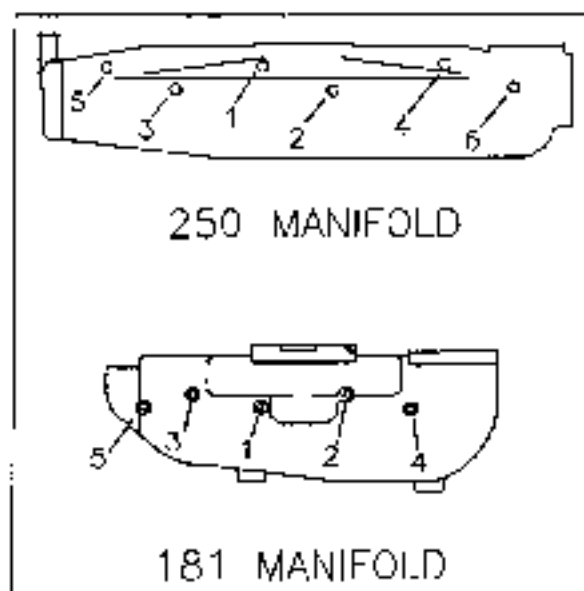

Manifold Torque Sequence

INTAKE-EXHAUST MANIFOLD REPLACEMENT

(Continued)

Tighten:

- Torque bolts in two stages:
 - 1st stage: 20 N·m (15 ft.lb.)
 - Final stage: 34 N·m (25 ft.lb.)
3. Throttle linkage.
 4. Coolant.
 5. Automatic chokewire to carburetor.
 6. Fuel lines to the carburetor.
 7. Crankcase ventilation hose to valve cover.
 8. Freshwater coolant hoses (if equipped).
 9. Thermostat housing-to-manifold coolant hose (seawater cooled).
 10. Engine coolant (See "Cooling Systems" section in this manual.)
 11. Battery negative cable.

MANIFOLD RISER REPLACEMENT**Remove or Disconnect:**

1. Battery negative cable.
2. Partially drain coolant system by removing the rear coolant plug on the manifold.

NOTE: Store drained coolant in a clean, sealable container for reuse; ethylene glycol coolant is highly poisonous to humans and pets and should be kept out of their reach.

3. Coolant hose at riser (freshwater cooled engines only).
4. Riser-to-manifold bolts.
5. Riser.
6. Manifold/riser gasket (raw water cooled engines). **NOTE:** On freshwater cooled engines, remove the freshwater blocking plate.

Clean or Inspect:

1. Gasket material or sealant from both surfaces.
2. Manifold and riser for cracks at the coolant ports and bolt holes. If cracks are found, replace.

IMPORTANT! Avoid getting sealant or gasket particles on coolant parts in manifold as this may cause a blockage in the cooling system, thus overheating the engine.

Install or Replace:

IMPORTANT! On four cylinder, 181 CID engines (freshwater or raw water cooled) if Marine Power aluminum manifold, part #0993-300F4, is used. **DO NOT** apply sealant to the silicone riser gasket!

1. Gasket (raw water cooled engine) or coolant block-off plate (fresh water cooled engine). **NOTE:** On the six-cylinder 250 CID engine, use Permatex® sealant or equivalent on the gasket and coolant block-off plate.
2. Riser to manifold and bolts.

Tighten:

- In diagonal sequence until it is insured that riser is secure and no leaks will exist.
3. Coolant hose at riser (freshwater cooled only).
 4. Coolant (See "Cooling Systems" section in this manual.)
 5. Battery negative cable.

**THERMOSTAT HOUSING REMOVAL
(Freshwater Cooled Engine)****Remove or Disconnect:**

1. Battery negative cable.
2. Coolant (See "Cooling Systems" section in this manual.)
3. Coolant hose at thermostat housing. This hose routes from the thermostat housing to the riser.
4. Temperature sensor protection bracket on top of housing (if equipped).
5. Temperature sensor wires on thermostat housing (if equipped). **NOTE:** Mark the sensor wires for proper installation.

THERMOSTAT HOUSING REMOVAL (Continued)

6. Housing bolts.
7. Thermostat housing.
8. Thermostat.

Clean or Inspect:

1. Gasket material from housing. *NOTE: Insure gasket material and sealant do not enter the coolant system.*
2. Housing for cracks or pitting, replace if necessary.

Install or Connect:

1. Gasket on thermostat housing. *NOTE: Use Permatex® or equivalent sealant on both sides of the gasket to insure proper seal.*
2. Thermostat (if removed).
3. Thermostat housing and bolts.

Tighten:

- Thermostat housing bolts to 20 N•m (15 ft.lbs.)
4. Temperature sensor wires to thermostat housing sensors (if equipped).
 5. Temperature sensor protection bracket on top of thermostat housing.
 6. Coolant hose at thermostat housing.
 7. Coolant (*See "Cooling Systems" section in this manual.*)
 8. Battery negative cable.

**THERMOSTAT HOUSING REMOVAL
(Raw Water Cooled Engines)**

Remove or Disconnect:

1. Battery negative cable.
2. Coolant (*See "Cooling Systems" section in this manual.*)
3. Coolant hose at the thermostat housing; this hose connects the thermostat housing to the intake-exhaust manifold.
4. Thermostat housing bolts.

5. Thermostat housing. *NOTE: It may be necessary to bump the housing with a rubber mallet to free it.*

Clean or Inspect:

1. Gasket material and sealant from thermostat housing surfaces. *NOTE: Insure gasket material and sealant do not enter cooling system.*
2. Thermostat housing for cracks or pitting, replace if necessary.

Install or Connect:

1. Gasket on thermostat housing. *NOTE: Use Permatex® or equivalent sealant on both sides of the gasket to insure a proper seal.*
2. Thermostat (if removed).
3. Thermostat housing and bolts.

Tighten:

- Thermostat housing bolts to 20 N•m (15 ft.lbs.)
4. Coolant hose at the thermostat housing.
 5. Coolant (*See "Cooling Systems" section in this manual.*)
 6. Battery negative cable.

CIRCULATION PUMP REPLACEMENT

Remove or Disconnect:

1. Battery negative cable.
2. Coolant (*See "Cooling Systems" section in this manual.*)
3. Circulation pump drive belt by loosening the alternator bolts and rotating alternator inward toward the block.

NOTE: It is helpful to loosen, not remove, the circulation pump pulley bolts before loosening the pump drive belt.

4. Circulation pump pulley bolts and pulley.
5. Circulation pump-to-block bolts.

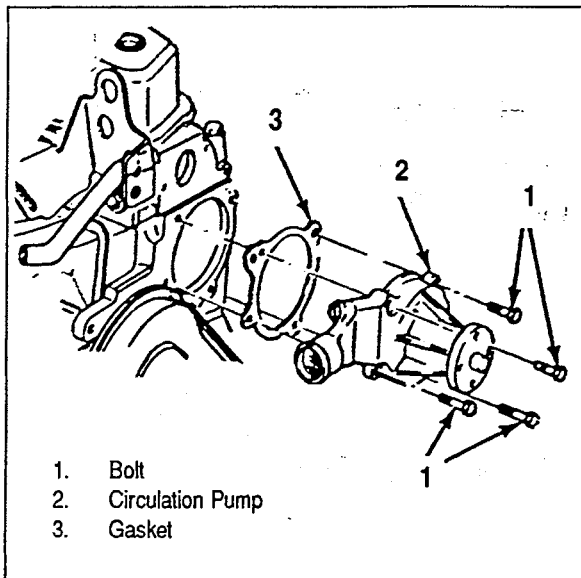
CIRCULATION PUMP REPLACEMENT (Continued)**Circulation Pump Replacement**

6. Circulation pump. *NOTE: It may be necessary to bump the pump with a rubber mallet to free it.*

Clean or Inspect:

1. Gasket material and sealant from pump and engine block. *NOTE: Insure gasket material and sealant do not enter the cooling system.*
2. Pump for roughness in operation.

Install or Connect:

1. Gasket on circulation pump. *NOTE: Use Permatex® sealant or equivalent on both sides of gasket to insure a proper seal.*
2. Circulation pump and bolts.

Tighten:

- Circulation pump bolts to 20 N•m (15 ft.lbs.)

3. Circulation pump pulley and bolts.

Tighten:

- Pulley bolts to 13 N•m (10 ft.lbs.)

4. Circulation pump drive belt.

Tighten:

- Drive belt at alternator to ½" deflection.

5. Coolant (See "Cooling Systems" section in this manual.)
6. Battery negative cable.

VALVE TRAIN COMPONENT REPLACEMENT**Tools Required:**

- J-3049 Valve Lifter Remover (Plier Type)
- J-8062 Valve Spring Compressor

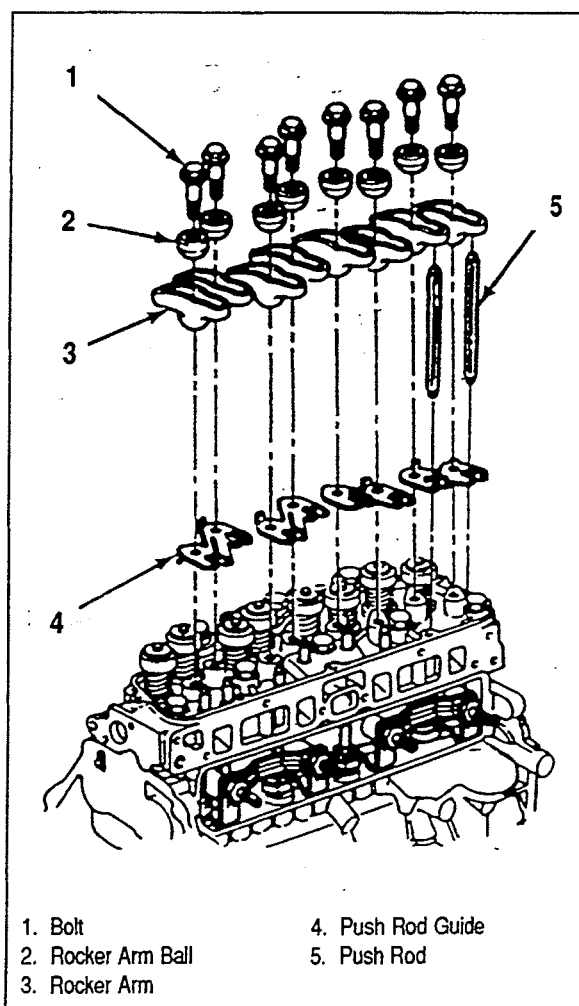
**Valve Train Components**

- | | |
|--------------------|-------------------|
| 1. Bolt | 4. Push Rod Guide |
| 2. Rocker Arm Ball | 5. Push Rod |
| 3. Rocker Arm | |

**VALVE TRAIN COMPONENT REPLACEMENT
(Continued)**

Remove or Disconnect:

1. Battery negative cable.
2. Coolant (See "Cooling System" section in this manual.)
3. Crankcase ventilation hose.
4. Rocker arm cover bolts.
5. Rocker arm cover.
6. (1) Rocker arm bolts, (2) balls, (3) rocker arms, (4) guides and (5) pushrods.

NOTE: It is essential that these mating parts be installed in their original locations during assembly. A simple valve train component organizer rack can be made from a block of wood as shown in the figure below. This figure shows the rack for the four cylinder engine, however, to make a rack for the six cylinder engine, simply make provisions for two more cylinders in the block of wood.

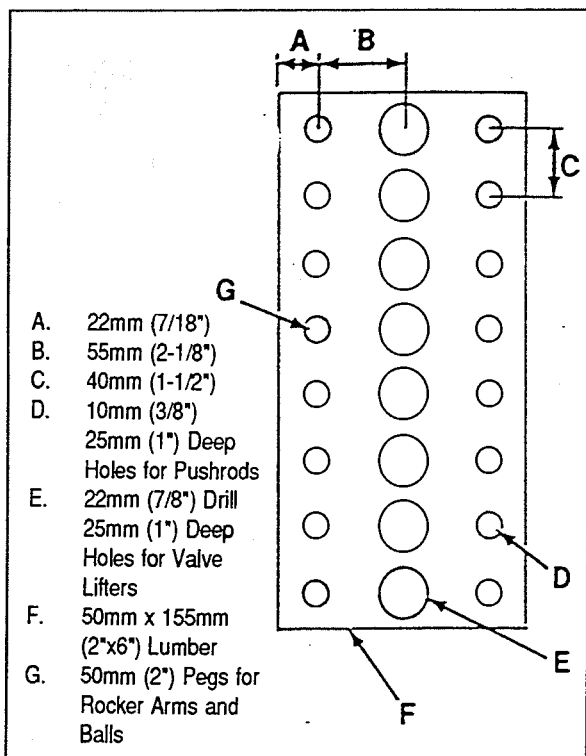

Valve Train Component Rack

7. Pushrod cover bolts, rubber washers, and the pushrod cover. (Located on starboard side of engine.)
8. Hydraulic lifters. **NOTE:** Remove the lifters one at a time and place in the organizer rack. The lifters must be installed in the same bores from which they were removed.
 - A stuck lifter can be removed using the tool: J-3049.
 - Valve train reassembly is covered under cylinder head replacement.

CYLINDER HEAD REPLACEMENT

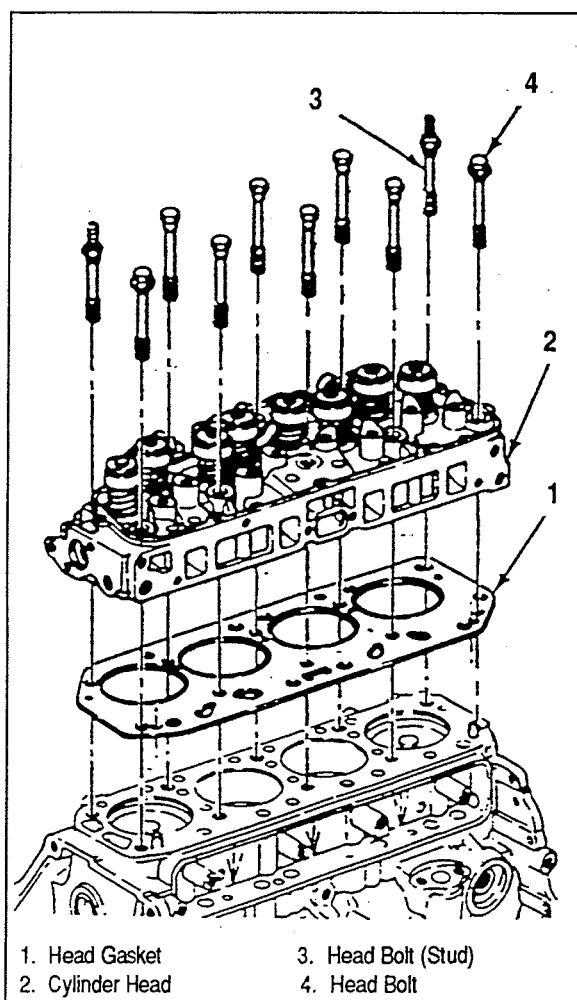

Cylinder Head Components

CYLINDER HEAD REPLACEMENT (Continued)

Remove or Disconnect:

1. Battery negative cable.
2. Coolant (See "Cooling System" section in this manual.)
3. Crankcase ventilation hose.
4. Valve train components. *NOTE: See "Valve Train Component Replacement" for proper procedure.*
5. Cylinder head bolts.
6. Cylinder head. *NOTE: DO NOT allow foreign material to get into cooling system.*
7. Cylinder head gasket. *NOTE: DO NOT allow foreign material to get into cooling system.*

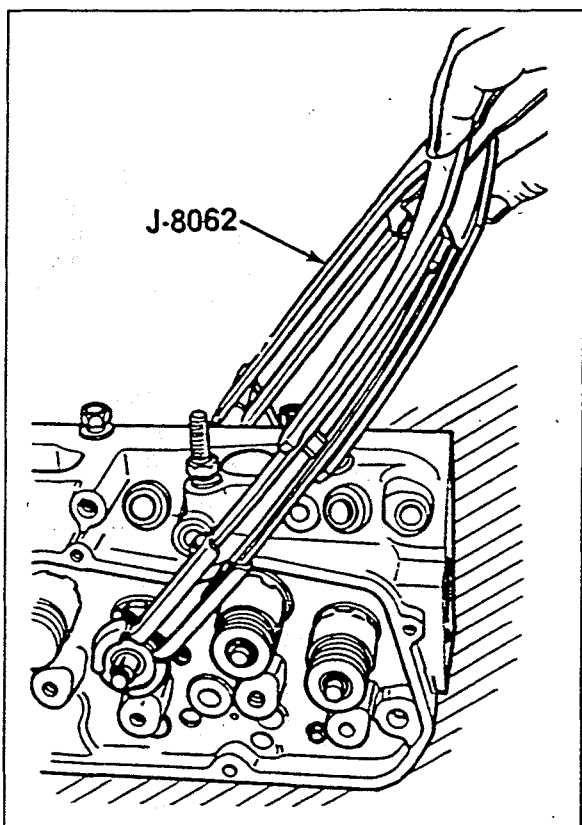

Compressing the Valve Springs

8. Valve keepers.
 - Compress the valve spring using tool J-8062.
 - Remove the valve keepers.
 - Remove the tool.
9. Valve spring cap.

10. Valve stem oil seals.
11. Valves. *NOTE: Place the valves in a valve rack so they can be returned to their original location during assembly.*

Install or Connect:

Tools Required:

- J-8062 Valve Spring Compressor
- J-22330 Valve Stem Seal Checker/Tester

1. New valve stem oil seals. *NOTE: Lubricate the seal to aid assembly.*
 - Push the new valve stem oil seal on to the valve stem. The seal is to be installed on the lower groove of the stem. Insure the seal is flat and not twisted.
2. Intake and exhaust valves into the cylinder head. *NOTE: Lubricate the valve stems with engine oil. Insure the valves are in their proper ports.*
3. Valve stem oil shield.
4. Valve spring cap.

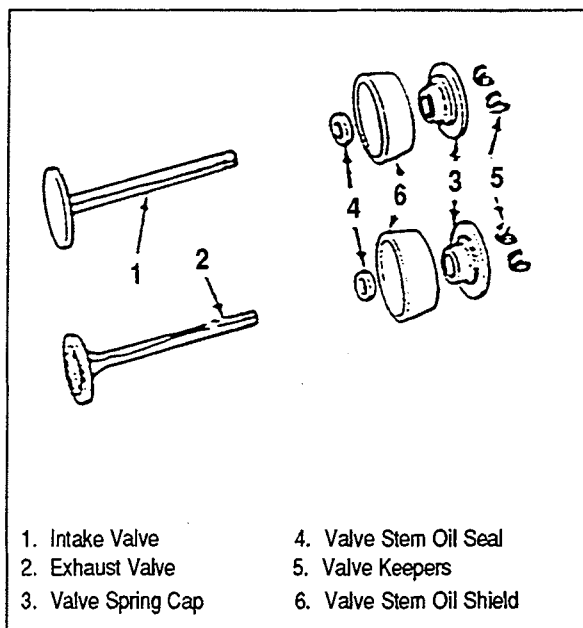

- | | |
|---------------------|--------------------------|
| 1. Intake Valve | 4. Valve Stem Oil Seal |
| 2. Exhaust Valve | 5. Valve Keepers |
| 3. Valve Spring Cap | 6. Valve Stem Oil Shield |

Valves and Components

5. Valve keepers.
 - Compress the valve springs using J-8062. Compress it enough so the lower valve stem groove can be clearly seen.

CYLINDER HEAD REPLACEMENT (Continued)

- Apply grease to the area of the upper valve stem groove. Assemble the two valve keepers, using the groove to hold the keepers in place.
- Insure the keepers are properly seated in the groove on the valve stem.
- Repeat the preceding steps on the remaining valves.
- Check each valve seal using tool J-22330. Wet the suction cup portion of the tool lightly with the engine oil. Place the suction cup over the valve stem cover and push the tool down to create a vacuum. If the vacuum remains at the tool, the seal is properly installed. If a vacuum cannot be obtained, or if the seal will not hold a vacuum, it may have been damaged or improperly installed.

Measure:

- Valve spring installed height.
 - Measure from the valve shim or the spring seat to the top of the valve cap with a thin, narrow scale.
 - If the measurement exceeds the figure given in the "Specifications" section of this manual, it will be necessary to install valve stem spring seat shims of proper thickness between the spring and cylinder head to the desired height. **NOTE:** Never shim the spring to give an installed height of less than the specified figure.

- Head gasket to the block. Install over the dowel pins. **NOTE:** Insure the block and cylinder head sealing surfaces are clean.
- Cylinder head. **NOTE:** Very carefully guide the head into place over the dowel pins. This may require assistance with the six cylinder head.
- Cylinder head bolts. **NOTE:** Cylinder head bolts should be washed in solvent and dried at the time of installation. All residual oil should be wiped from the cylinder head mating surfaces.
 - Coat threads of the head bolts with Permatex® or equivalent.

Tighten:

- All head bolts to 25 N•m (18 ft.lbs.) in the sequence shown in next figure.

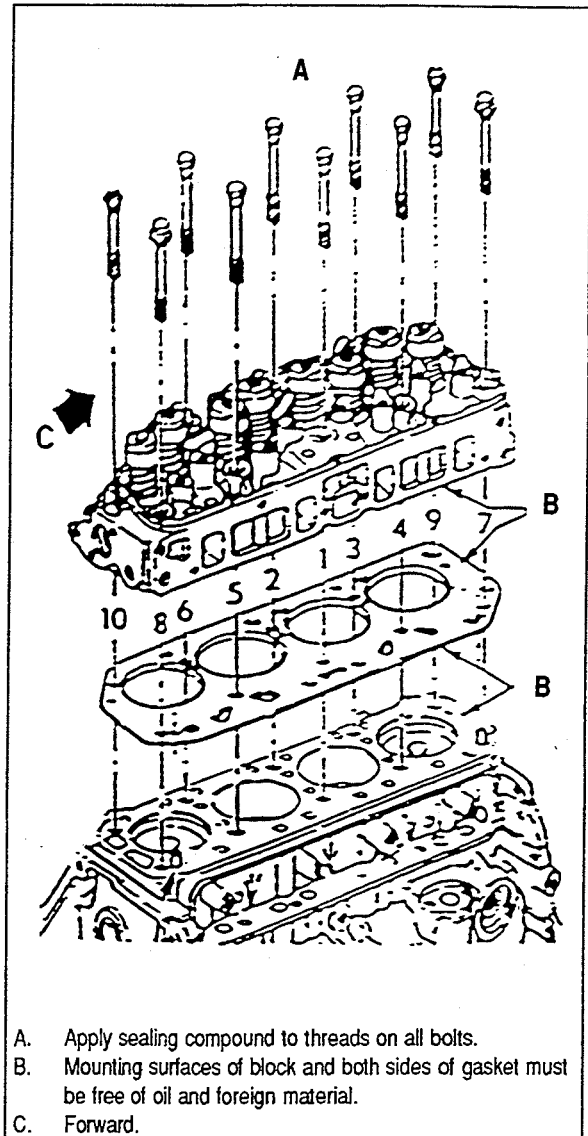
**Cylinder Head Installation**

- All head bolts again to 41 N•m (30 ft.lbs.) in the sequence shown in next figure.
- All head bolts to a final torque of 136 N•m (100 ft.lbs.) in the sequence shown in the next figure.
- Hydraulic lifters into their mating bores in the block. **NOTE:** Lubricate the lifters with an engine oil supplement before installing in the block.
- Pushrod cover to block. **NOTE:** Apply a continuous bead (3/16" wide) of RTV around the perimeter of the pushrod cover mating surface and install cover while RTV is still wet.
- Pushrod cover bolts and rubber washers.

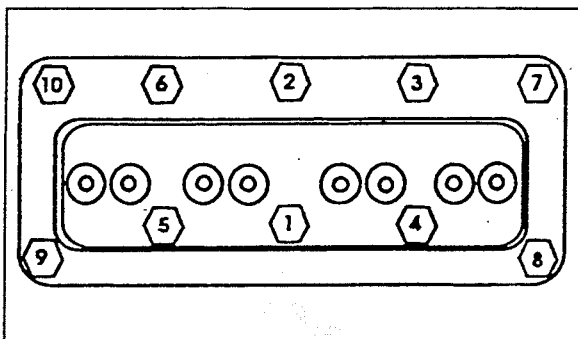
CYLINDER HEAD REPLACEMENT (Continued)

**Four Cylinder Torque Pattern
(Six cylinder is similar)**

12. Pushrods. Seat pushrods into the sockets of the hydraulic lifters.
13. Rocker arms. *NOTE: Coat the mating surfaces of the rocker arms and balls with molybdenum disulfide grease.*
14. Rocker arm balls and bolts.

Tighten:

- Rocker arm bolts to 30 N•m (22 ft. lbs.) **DO NOT OVERTIGHTEN!**

15. Rocker arm cover to the cylinder head. *NOTE: Apply a continuous bead (3/16" wide) of RTV sealant around the perimeter of the rocker arm cover, inboard of all the holes, and install cover while sealant is still wet.*
16. Rocker arm cover bolts.

Tighten:

- Bolts to 8.5 N•m (75 in.lbs.)

17. Crankcase ventilation hose.
18. Coolant. (See "Cooling Systems" section in this manual.)
19. Battery negative cable.

TORSIONAL DAMPER REPLACEMENT

Tools required:

- J-5590 Damper Installation Tool
- J-6978-E Torsional Damper Puller

Remove or Disconnect:

1. Battery negative cable.
2. Alternator drive belt and seawater pump drive belt (if equipped).
3. Seawater pump driver pulley (if equipped). *NOTE: The seawater pump driver pulley is bolted to the torsional damper.*
4. Torsional damper using tool J-6978-E torsional damper puller. *NOTE: Do not use the standard jaw-type pullers as this will break the rubber damping material away from the hub rendering the damper useless.*

Clean or Inspect:

1. Damper surface for cracks or chips and replace if necessary.
2. Crankshaft surface for scoring or nicks.
3. Damper key and keyway for chips or cracks.

Install or Connect:

1. Crankshaft key in crankshaft.
2. Torsional damper using tool J-5590. *NOTE: Coat engine oil seal contact area on the damper with engine oil.*
 - Position damper over crankshaft, aligning the key on the crankshaft with the keyway in the damper.
 - Drive the hub onto the crankshaft using tool J-5590 and a rubber mallet until the damper bottoms on the crankshaft gear.
3. Seawater pump driver pulley to damper (if equipped).
4. Alternator drive belt and seawater pump drive belt (if equipped). *NOTE: Tighten all belts to ½" deflection.*
5. Battery negative cable.

OIL PAN REPLACEMENT**Remove or Disconnect:**

1. Battery negative cable.
2. Oil from engine. *NOTE: See "Oil Drain/Change" section in this manual.*

OIL PAN REPLACEMENT (Continued)

NOTE: It may be necessary to raise the engine slightly. However, in some cases, it may be necessary to remove the engine from its mountings.

3. Flywheel dust cover.
4. Starter and wiring.
5. Oil pan bolts.
6. Oil pan. *NOTE: It may be necessary to bump the end of the oil pan with a rubber mallet to shear the sealant between the block and the oil pan. Very carefully pry the oil pan loose if bumping the pan is unsuccessful. Take extreme care not to distort the sealing flange.*

Clean or Inspect:

1. Sealant or gasket material from both the engine block and oil pan.
2. Inside bottom of oil pan for metal shavings or other signs of internal damage.
 - Investigate further if damage is suspected.
3. Any sludge or varnish build-up.
4. Gasket sealing flange for bends or damage.

Install or Connect:

NOTE: Apply RTV sealant to the oil pan gasket flange, going inboard of bolt holes, in a continuous bead. Also, apply along sides of the rear main bearing cap and on the corners of the front engine cover. Install oil pan while RTV is still wet.

1. Oil pan and bolts.

Tighten:

- Oil pan bolts to 10 N·m (90 in.lbs.)

2. Starter and wiring.
3. Flywheel dust cover.
4. Lower engine, if raised.
5. Engine oil.
6. Battery negative cable.

OIL PUMP REPLACEMENT**Remove or Disconnect:**

1. Oil Pan. *NOTE: See "Oil Pan Replacement" section in this manual for procedure.*
2. Bolt and nut at the oil screen bracket.
3. Oil pump.
 - Disassemble oil pump. (see figure below)
 - Cover screws
 - Cover
 - Gasket
 - Drive gear and shaft *NOTE: Mark the gear teeth so they may be installed with the same gear teeth indexed. Do not score or scratch a mark into gears, use marker or pencil.*
 - Idler gear
 - Spring retaining pin
 - Spring
 - Pressure relief valve
 - Pickup screen and pipe only if necessary and are serviced as an assembly only

Clean or Inspect:

1. All parts in clean solvent and blow dry with compressed air.
2. Pump body and cover for cracks or other damage.
3. Gears for wear.
4. Drive gear and shaft for looseness in the pump body.
5. Inside the cover for wear which would permit oil to leak past the ends of the gears.
6. The pump gears and body are to be serviced together, not separately.
7. Pressure relief valve for fit.
 - Regulator valve should slide freely in its bore without sticking or binding.

Install or Connect:**Tools required:**

J-21882 Oil Suction Pipe Installer

OIL PUMP REPLACEMENT (Continued)

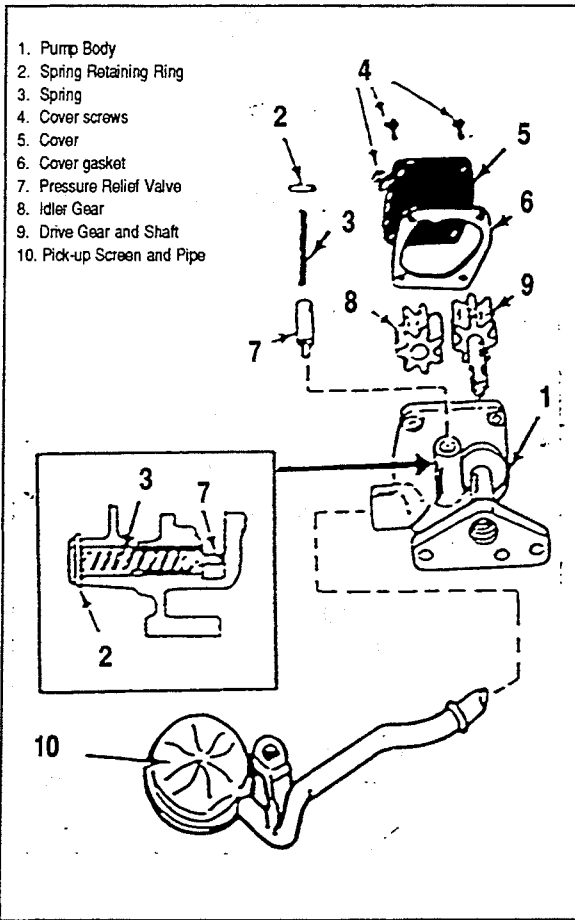

Oil Pump Components

1. Pressure relief valve.
2. Spring.
3. Spring retaining pin.
4. Drive gear and shaft.
5. Idler gear in the pump body. *NOTE: Smooth side of the gear goes toward the pump cover opening. Align the marks previously made on the gears during disassembly.*
6. Gasket.
7. Cover and screws.

Tighten:

- Screws to 14 N·m (10 ft.lbs.)
- Turn pump drive shaft by hand to check for smooth operation.

8. Pick-up screen and pipe (if removed). *NOTE: If the pick-up screen and pipe assembly was removed, it should be replaced with a new part. Loss of press fit condition may result in an air leak and loss of oil pressure.*
 - Mount oil pump in a soft-jawed vise.
 - Apply sealant to the end of the pipe.
 - Tap the pick-up screen and pipe into place using tool J-21882 and a hammer as shown in figure below.
 - The pump screen must be parallel with the bottom of the oil pan when installed.

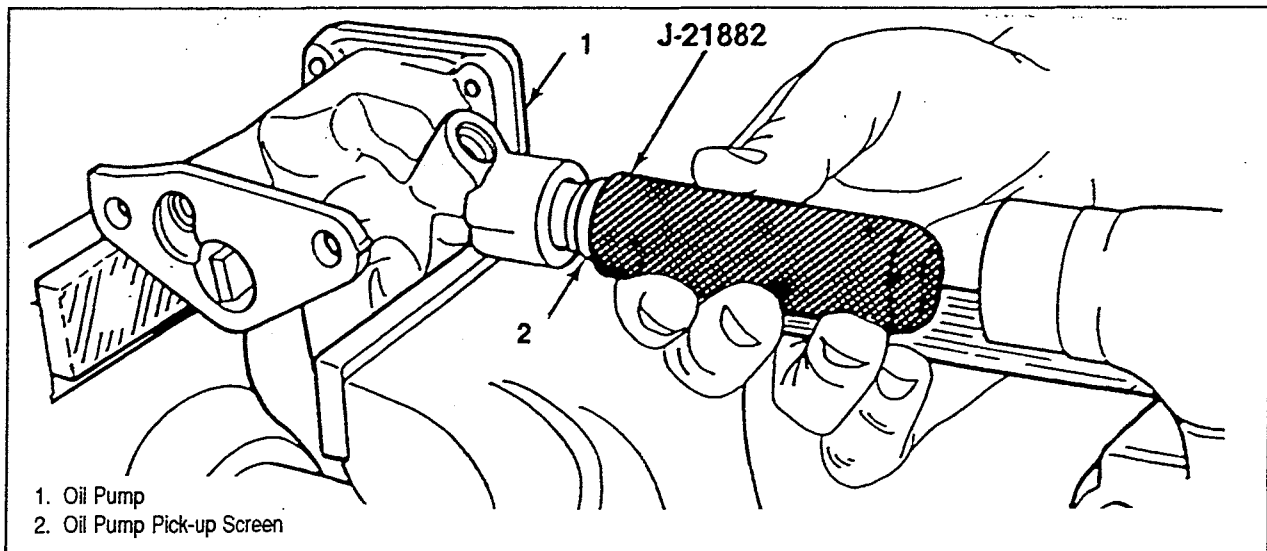

Installing the Oil Suction Pipe

TIMING GEAR COVER REPLACEMENT

Remove or Disconnect:

1. Battery negative cable.
2. Torsional damper. *NOTE: See "Torsional Damper Replacement" section in this manual.*
3. Timing gear cover bolts.
4. Timing gear cover. *NOTE: It may be necessary to pry the cover loose, if so, do not distort the sealing flange.*
5. Cover seal.
 - Pry out with screwdriver.

Clean or Inspect:

1. Sealant from cover sealing flange and engine block.
2. Front cover for cracks, large dents, etc.
3. Sealing flange straightness.

Install or Connect:

Tool required:

J-34995 Crankshaft Front Cover Oil Seal Installer

1. New front cover seal using tool J-34995. *NOTE: Support the inside of the front cover around the seal bore area.*
 - Press seal into place. The open end of the seal faces the inside of the cover.
 - Lubricate the seal lips with grease.
 - Leave tool in place.
2. Timing gear cover, with tool J-34995 in place, to the block. *NOTE: Apply a 10mm (3/8") wide by 5mm (7/16") thick bead of RTV sealer to the oil pan at the timing gear cover sealing surface.*
 - Apply a 6mm (1/4") wide by 3mm (1/8") thick bead of RTV to the timing gear cover at the block sealing surface. See next figure.
3. Timing cover bolts.

Tighten:

- Bolts to 10 N•m (90 in.lbs.)

4. Remove tool J-34995 from timing gear cover.

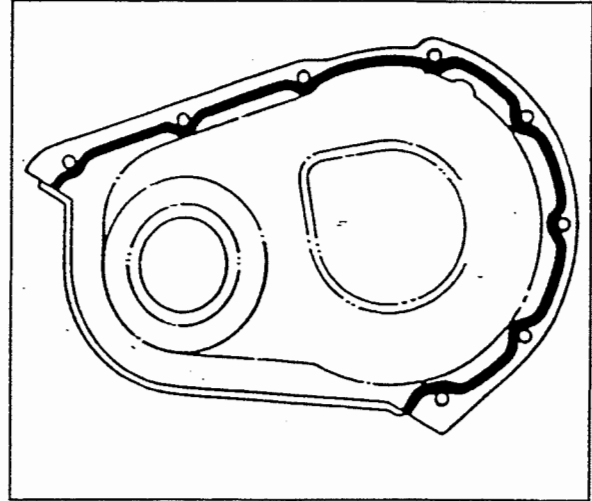

Applying RTV to the Timing Gear Cover

5. Torsional damper. *NOTE: See "Torsional Damper Replacement" section in this manual.*
6. Battery negative cable.

PISTON AND CONNECTING ROD REPLACEMENT

NOTE: It may be necessary to raise the engine slightly. However, in some cases, it may be necessary to remove the engine from its mountings.

Remove or Disconnect:

1. Battery negative cable.
2. Cylinder head. *NOTE: See "Cylinder Head Replacement" section in this manual.*
3. Oil pan. *NOTE: See "Oil Pan Replacement" section in this manual.*
4. Ridge at the top of the cylinder as follows:
 - Turn crankshaft until one piston is at the bottom of its stroke. Place a clean, soft cloth on top of the piston.
 - Following manufacturer's directions, install a ridge reamer into the top of the cylinder and perform the cutting operation.

PISTON AND CONNECTING ROD REPLACEMENT (Continued)

- After the ridge is removed, remove the ridge reamer. Turn the crankshaft until the piston is at the top of its stroke and remove the cloth and the metal shavings.
 - Repeat this procedure for each cylinder.
5. Connecting rod caps as follows:
- **NOTE:** To avoid mismatching the connecting rod caps, remove only one connecting rod cap at a time.
 - Observe the arrangement of the connecting rod markings so they may be reassembled in the same arrangement. Mark them if necessary.
 - Place the piston at the bottom of its stroke.
 - Remove the connecting rod cap nuts and the connecting rod cap. **NOTE:** To avoid scratching or gouging the crankshaft journals or the cylinder bore, place a short section of 3/8" rubber hose over the connecting rod studs.
6. Connecting rod and piston from the block.
- Push the connecting rod and piston from the block. **NOTE:** Do not allow connecting rod to contact the cylinder bore.
 - Loosely assemble the connecting rod cap on to the connecting rod.
 - Take note of the connecting rod and piston assembly and cylinder bore to insure each assembly is returned.
 - Repeat this procedure on the remaining connecting rod assemblies.

Clean or Inspect:

- **NOTE:** For cylinder bore, piston and connecting rod inspection procedures, refer to "Mechanical Procedures" in this manual.

Install or Replace:

Tool required:

J-8037 Piston Ring Compressor

- Insure cylinder walls are clean. Lubricate the cylinder wall lightly with engine oil.
 - Insure the piston and connecting rod assemblies are installed in their matching cylinders.
1. Connecting rod bearing inserts.
- Insure the inserts are the proper size.

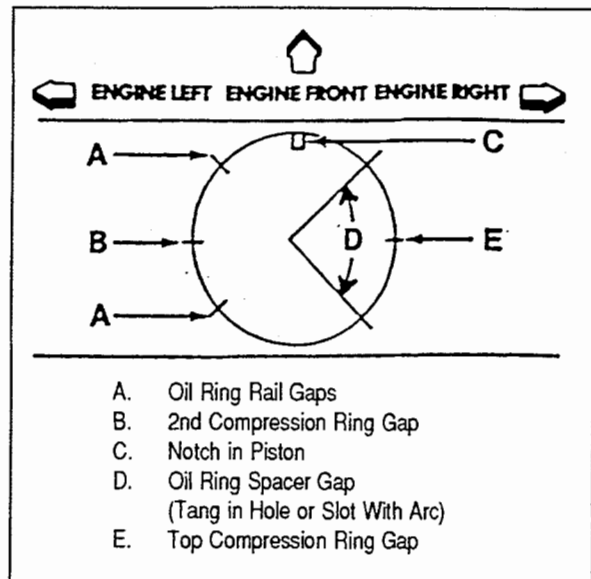

Piston Ring Gap Location

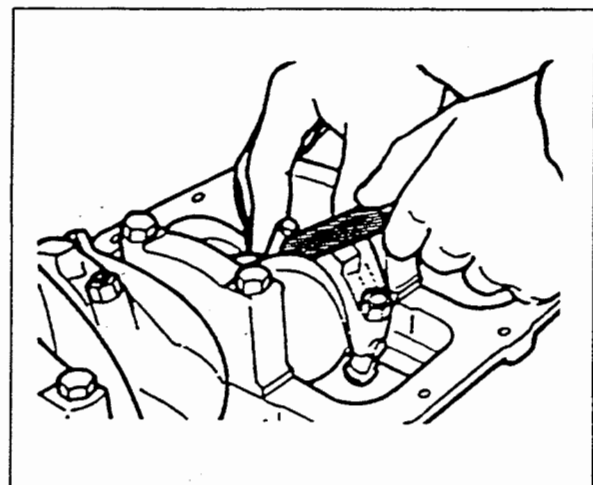

Measuring Connecting Rod Side Clearance

- Install the inserts in the connecting rod and cap.
 - Lubricate the bearings with engine oil.
2. Piston and connecting rod to the proper bore:
- Remove connecting rod cap and install two sections of 3/8" diameter hose on connecting rod studs.
 - Locate the piston ring end gaps as shown in the previous figure. Lubricate the piston and rings with engine oil.
 - Without disturbing the ring end gap location, install tool J-8037 over the piston.
 - Piston must be installed so that the notch in piston faces the front of the engine.

PISTON AND CONNECTING ROD REPLACEMENT (Continued)

- Place the piston in its matching bore (ring compressor should be squarely against the bore). Using light blows with a hammer handle, tap the piston down into the bore. As the piston is being tapped down into the bore, guide the connecting rod down into position on the crankshaft journal. Hold the ring compressor against the block until the piston is completely in the cylinder.
- 3. Connecting rod cap with the lower connecting rod bearing insert. *NOTE: Apply engine oil to the connecting rod bearing inserts and the crankshaft journal.*
- 4. Connecting rod cap nuts.

Tighten:

- Nuts to 40 N•m (30 ft.lbs.)

Measure:

1. Connecting rod side clearance. Use a feeler gauge between the connecting rod and the crankshaft. The correct clearance is 0.15-0.60 mm (0.006-0.022 inch). Refer to next figure.
2. Oil pan. *NOTE: See "Oil Pan Replacement" section in this manual.*
3. Cylinder head. *NOTE: See "Cylinder Head Replacement" section in this manual.*
4. Engine in boat or lower in place, if necessary.
5. Battery negative cable.

FLYWHEEL REPLACEMENT

Remove or Disconnect:

1. Battery negative cable.
2. Transmission oil cooler lines at the transmission. *NOTE: Cap all lines and parts to eliminate contamination.*
3. Shift control linkages and wiring at transmission.
4. Starter. *NOTE: Support rear portion of engine with suitable and stable support device(s).*
5. Transmission and bell housing.
6. Flywheel bolts.
7. Flywheel.

Install or Connect:

1. Flywheel to crankshaft.
2. Flywheel bolts.

Tighten:

- Bolts to 90 N•m (65 ft.lbs.)
3. Transmission and bell housing. *NOTE: Raise rear of engine with suitable, stable jack to ensure a proper line up of engine and transmission.*
 4. Starter.
 5. Shift control linkage and wiring to the transmission.
 6. Transmission oil cooler lines to the transmission. *NOTE: Insure all caps and plugs are removed before installing lines to transmission.*
 7. Battery negative cable.

CRANKSHAFT REPLACEMENT

Remove or Disconnect:

NOTE: Check the main bearing caps' location markings. The caps are numbered 1-5 (on the four cylinder) and 1-7 (on the six cylinder) from the front to the rear of the engine. The caps must be returned to their original locations during assembly.

1. Engine from boat. *NOTE: It is advantageous to place the engine on an acceptable engine stand and rotate it 180° (oil pan facing up).*
2. Front timing cover. *NOTE: See "Front Cover Replacement" section in this manual.*
3. Oil pan. *NOTE: See "Oil Pan Replacement" section in this manual.*
4. Crankshaft timing gear.
5. Main bearing cap bolts.
6. Main bearing caps. *NOTE: Maintain caps in order of removal.*
7. Crankshaft. *NOTE: Lift crankshaft straight up, taking care not to damage the journals or the thrust flange surfaces of the crankshaft.*
8. Rear crankshaft seal.
9. Main bearing inserts. *NOTE: If main bearing inserts are to be reused, mark them to insure they are installed in their original positions before removal.*

CRANKSHAFT REPLACEMENT (Continued)**Clean or Inspect:**

1. Crankshaft with solvent. *NOTE: Take care not to scratch the bearing journals while cleaning.*
2. Crankshaft oil passages of any sludge using compressed air.
3. Main bearing inserts of any dirt or oil.
4. Crankshaft for cracks using magnaflux method, if possible.
5. Crankpins, main bearing journals and thrust surfaces for scoring, nicks, scratches or damage caused by the lack of lubrication.
6. Main bearing inserts for scoring or other damage. *NOTE: Generally, the lower inserts show a greater sign of wear and fatigue. Upon inspection, if the lower insert is found suitable for use, it can be assumed that the upper insert is also suitable. If the lower insert shows evidence of wear or damage, then both upper and lower inserts should be replaced.*
7. Crankshaft timing gear for damaged teeth.

Measure:

- Main bearing and connecting rod journal diameters. Compare with "Specifications" at the end of the section.
- Main bearing and connecting rod journals for taper and out-of-round.
- Crankshaft run-out.

Install or Connect:

NOTE: Lubricate all moving parts with clean engine oil prior to assembly.

1. Upper main bearing inserts to the block. *NOTE: If any previously used or undersized bearings are used, insure that they are fitted to the proper journal.*
2. Crankshaft. *NOTE: Take care not to damage the thrust areas.*
3. Lower bearing inserts to the bearing caps. *NOTE: Apply engine oil to the lower bearing inserts.*
4. Main bearing caps (except the rear cap) with the lower main bearing inserts. *NOTE: Insure the main bearing caps are in their original positions (arrows facing the front of the engine).*

5. Bolts. *NOTE: The special bolt which supports the oil pump pickup tube and screen should be installed on the #4 main bearing cap, camshaft side (#5 main bearing cap, camshaft side on the six cylinder).*

Tighten:

- Main bearing cap bolts to 88 N•m (65 ft.lbs.)

6. Rear main bearing cap to the block.
7. Rear main bearing cap bolts. *NOTE: Temporarily tighten bolts to 14 N•m (10 ft.lbs.)*

Measure:

1. Crankshaft end play as follows:
 - Top the end of the crankshaft first rearward then forward with a lead hammer. This lines up the rear main bearing and crankshaft thrust surfaces.
 - Tighten rear main bearing cap bolts to 88 N•m (65 ft.lbs.)
 - With crankshaft forced forward, measure at the front end of the rear main bearing with a feeler gauge. The clearance should be 0.09-0.20 mm (0.0035-0.0085 inch). See next figure.

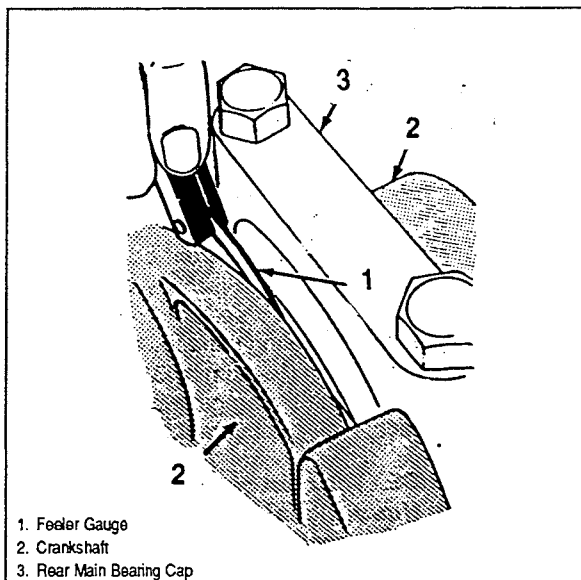

Measuring Crankshaft End Play

Inspect:

1. Crankshaft for binding as follows:
 - Turn crankshaft by hand, if it doesn't turn freely, loosen the main bearing cap bolts one pair at a

CRANKSHAFT REPLACEMENT (Continued)

time, until the tight bearing is located. Burrs on the bearing cap, foreign matter between the insert and the block or bearing cap, or a faulty insert could cause a lack of clearance at the bearing.

2. Rear crankshaft oil seal.
3. Crankshaft timing gear.
4. Oil pan. *NOTE: See "Oil Pan Replacement" section in this manual.*
5. Front timing cover. *NOTE: See "Front Timing Cover Replacement" section in this manual.*
6. Engine in boat.

CRANKSHAFT REAR OIL SEAL REPLACEMENT

Tool Required:

J-34924-A Seal Installer

Remove or Disconnect:

1. Battery negative cable.
2. Engine flywheel. *NOTE: See "Flywheel Replacement" section in this manual.*
3. Rear crankshaft oil seal. *NOTE: Pry out the seal with a screwdriver taking care not to scratch the crankshaft.*

Inspect:

1. Crankshaft surface for nicks and scratches.

Install or Connect:

1. Crankshaft rear oil seal as follows:
 - Lubricate the seal inside diameter with clean engine oil.
 - Slide the seal over the mandrel of the tool until the dust lip (back of seal) mates squarely against the collar.
 - Lubricate the seal outside diameter with engine oil.
 - Position the tool with the seal in place against the crankshaft. Align the dowel with the alignment hole in the crankshaft. Tighten the screws firmly.

- Turn the T-handle of the tool until the collar seats firmly against the crankcase. This will insure that the seal is seated properly.
 - Loosen the T-handle fully. Loosen the screws and remove the tool.
2. Engine flywheel. *NOTE: See "Flywheel Replacement" section in the manual.*
 3. Battery negative cable.

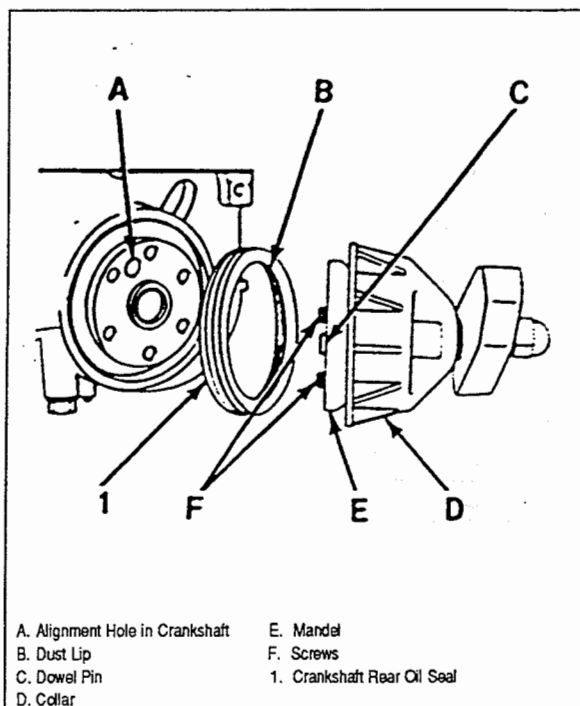

Installing the Rear Crankshaft Oil Seal

ENGINE SPECIFICATIONS

All Specifications are in INCHES unless otherwise noted.

GENERAL DATA:		181 CID (3.0L)	250 CID (4.1L)	
Type		L4	L6	
Displacement		181 CID (3.0L)	250 CID (4.1L)	
Bore		4.00" (101.60mm)	3.87" (98.30mm)	
Stroke		3.60" (91.4mm)	3.53" (89.66mm)	
Compression Ratio		8.5:1	8.5:1	
Firing Order		1 - 3 - 4 - 2	1 - 5 - 3 - 6 - 2 - 4	
Oil Pressure		36-41 psi @ 2000 rpm		
CYLINDER BORE:				
Diameter		3.9995 - 4.0075" (101.9873-101.7905mm)	3.8745 - 3.8775" (98.4123-98.4685mm)	
Out of Round		Desired Allowable	0.0005" Max (0.0127mm) 0.002" Max (0.0508mm)	
Taper - Thrust Side			0.0005" Max (0.0127mm)	
PISTON:				
Clearance		Desired Allowable	0.0005 - 0.0015" (0.0127-0.0381mm) 0.0025" (0.0635mm)	
PISTON RING:				
C O M P R E S S I O N	Groove Clearance	Top	Desired Allowable	0.0012 - 0.0027" (0.0305-0.0686mm) 0.0012 - 0.0037" (0.035-0.0940mm)
		Second	Desired Allowable	0.0012 - 0.0027" (0.0305-0.0686mm) 0.0012 - 0.0037" (0.035-0.0940mm)
	Groove Clearance	Top	Desired Allowable	0.010 - 0.020" (0.254-0.508mm) 0.010 - 0.030" (0.254-0.763mm)
		Second	Desired Allowable	0.010 - 0.020" (0.254-0.508mm) 0.010 - 0.030" (0.254-0.763mm)
O I L	Groove Clearance	Desired Allowable	0.000 - 0.005" (0.000-0.0127mm) 0.000 - 0.016" (0.000-0.152mm)	
	Gap	Desired Allowable	0.015 - 0.055" (0.381-1.397mm) 0.015 - 0.065" (0.381-1.651mm)	
PISTON PIN:				
Diameter		0.9270 - 0.9273" (23.5458-23.5534mm)		

ENGINE SPECIFICATIONS (Continued)

All Specifications are in INCHES unless otherwise noted.

GENERAL DATA:		181 CID (3.0L)	250 CID (4.1L)
PISTON PIN:			
Diameter		0.9270 - 0.9273" (23.5458-23.5534mm)	
Clearance in Piston	Desired Allowable	0.0015 - 0.0025" (0.0381-0.0635mm) 0.001" Max (0.0254mm)	
Fit in Rod	Interference	0.0008 - 0.0016" (0.0203-0.0406mm)	
CRANKSHAFT:			
Main Journal	Diameter	2.2983 - 2.2993" (58.3768-58.4022mm)	
	Taper	Desired Allowable	0.0002" Max (0.0051mm) 0.0010" Max (0.0254mm)
	Out of Round	Desired Allowable	0.0002" Max (0.0051mm) 0.0010" Max (0.0254mm)
Main Bearing Clearance	Desired Allowable	0.0003 - 0.0029" Max (0.0076-0.0737mm) 0.004" (0.1016mm)	
Crankshaft End Play		0.002 - 0.006" (0.0508-0.1524mm)	
Crankpin	Diameter	2.099-2.100" (53.315-53.340mm)	1.999-2.000" (50.7746-50.8000mm)
	Taper	Desired Allowable	0.0003" (0.0076mm) 0.001" (0.0254mm)
	Out of Round	Desired Allowable	0.0002" (0.0051mm) 0.001" (0.0254mm)
Rod Bearing Clearance	Desired Allowable	0.0007 - 0.0028" (0.0178-0.0711mm) 0.004" (0.1016mm)	
Rod Side Clearance		0.0009-0.0013" (0.0229-0.0330mm)	0.0085-0.0135" (0.2159-0.3429mm)
CAMSHAFT:			
Lobe Lift (Intake and Exhaust)		0.2525" Max (6.4135mm)	0.2297" Max (5.8344mm)
End Play		0.002 - 0.005" (0.06-0.1mm)	
Journal Diameter		1.8682 - 1.8692" (47.4523-47.4777mm)	
VALVE SYSTEM:			
Lifter Type		Hydraulic	
Valve Lash		3/4 Turn Past Zero Lash	

ENGINE SPECIFICATIONS (Continued)

All Specifications are in INCHES unless otherwise noted.

GENERAL DATA:		181 CID (3.0L)	250 CID (4.1L)
VALVE SYSTEM (Continued):			
Rocker Arm Ratio		1.75:1	
Face Angle (Intake & Exhaust)		45°	
Seat Angle (Intake & Exhaust)		46°	
Seat Runout (Intake & Exhaust)		0.002" Max (0.0508mm)	
Seat Width	Intake	0.0312 - 0.0625" (0.7925 - 1.5875mm)	
	Exhaust	0.0625 - 0.0937" (1.588-2.380mm)	
Stem Clearance	Intake	Desired Allowable	0.0010 - 0.0027" (0.0254-0.0686mm) 0.0037" Max (0.0940mm)
	Exhaust	Desired Allowable	0.0015 - 0.0032" (0.0381-0.813mm) 0.0052" Max (0.1321mm)

TORQUE SPECIFICATIONS

ENGINE MODEL	181 CID (3.0L)	250 CID (4.1L)
CYLINDER HEAD	90-100 ft.lbs. (122-136 Nm)	95 ft.lbs. (128 Nm)
CONNECTING ROD	30-35 ft.lbs. (40-47 Nm)	35 ft.lbs. (47 Nm)
CAMSHAFT THRUST PLATE	72-90 in.lbs. (40-47 Nm)	80 in.lbs. (9 Nm)
INTAKE/EXHAUST MANIFOLD	20-25 ft.lbs. (27-33 Nm)	25 ft.lbs. (33 Nm)
FLYWHEEL/COUPLER	60-65 ft.lbs. (81-88 Nm)	
MAIN BEARING CAP	60-70 ft.lbs. (81-94 Nm)	65 ft.lbs. (88 Nm)
OIL FILTER	Hand Tight	Hand Tight
OIL PAN 1/4"	72-90 in.lbs. (8-10 Nm)	
OIL PAN 5/16"	120-130 in.lbs. (12-14 Nm)	75 in.lbs. (8 Nm)
OIL PAN DRAIN	20 ft. lbs. (27 Nm)	20 ft. lbs. (27 Nm)
OIL PUMP TO BLOCK	115 in.lbs. (13 Nm)	115 in.lbs. (13 Nm)
OIL PUMP COVER	70 in.lbs. (8 Nm)	70 in.lbs. (8 Nm)
ROCKER ARM COVER	55 in. lbs. (6 Nm)	45 in.lbs. (5 Nm)

SPECIAL TOOLS



1 J-8037



6 J-21882



2 J-34995

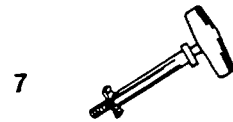

7 J-34144-A



3 J-8080

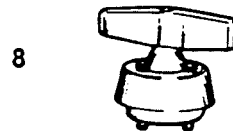

8 J-34924-A



4 J-8062



9 J-22330



5 J-33049



10 J-3049

- 1. Piston Ring Compressor
- 2. Front Crankshaft Seal Installer
- 3. Main Bearing Replacer
- 4. Valve Spring Compressor
- 5. Cam Bearing Replacer
- 6. Oil Pump Pickup Tube Installer
- 7. Rocker Arm Cover Remover
- 8. Rear Crankshaft Oil Seal Installer
- 9. Valve Seal Checker
- 10. Hydraulic Lifter Remover
- 11. Dial Indicator



11 J-7872

ENGINES: 262 CID (4.3L)

SECTION 11

INTRODUCTION.....	2
DESCRIPTION.....	2
ENGINE LUBRICATION.....	2
ENGINE LUBRICATION DIAGRAMS.....	4
ROCKER ARM COVER REPLACEMENT.....	5
ROCKER ARM AND PUSHROD REPLACEMENT.....	5
VALVE STEM SEAL AND VALVE SPRING REPLACEMENT.....	6
INTAKE MANIFOLD REPLACEMENT.....	8
HYDRAULIC LIFTER REPLACEMENT.....	9
ROCKER ARM STUD REPLACEMENT.....	11
EXHAUST MANIFOLD REPLACEMENT.....	12
EXHAUST MANIFOLD RISER REPLACEMENT.....	13
CYLINDER HEAD REPLACEMENT.....	13
TORSIONAL DAMPER AND FRONT CRANKSHAFT SEAL REPLACEMENT.....	14
FRONT COVER REPLACEMENT.....	15
OIL PAN REPLACEMENT.....	16
OIL PUMP REPLACEMENT.....	17
REAR CRANKSHAFT OIL SEAL REPLACEMENT.....	17
REAR CRANKSHAFT OIL SEAL RETAINER REPLACEMENT.....	18
MEASURING CAMSHAFT LOBE LIFT.....	19
CAMSHAFT REPLACEMENT.....	19
CONNECTING ROD AND PISTON REPLACEMENT.....	22
MAIN BEARING REPLACEMENT.....	24
OIL FILTER ADAPTER AND OIL FILTER BYPASS VALVE REPLACEMENT.....	25
CRANKSHAFT REPLACEMENT.....	26
FLYWHEEL REPLACEMENT.....	26
FLYWHEEL RING GEAR REPLACEMENT.....	26
ENGINE REPLACEMENT.....	27
ENGINE SPECIFICATIONS.....	28

INTRODUCTION

The following "Notice" applies to one or more steps in the assembly procedure of components in this portion of the manual as indicated at appropriate locations by the terminology "NOTICE".

NOTICE: When fasteners are removed, always reinstall them at the same location from which they were removed. If a fastener needs to be replaced, use the correct part number fastener for that application. If the correct part number fastener is not available, a fastener of equal size and strength (or stronger) may be used. Fasteners that are not roused, and those requiring thread locking compound will be called out. The correct torque value must be used when installing fasteners that require it. If the above conditions are not followed, parts or systems damage could result.

DESCRIPTION

4.3 L engines are 90° V6 type, overhead valve, water cooled with cast iron block and heads.

The crankshaft is supported by four precision insert main bearings, with crankshaft thrust taken at the number four (rear) bearing.

The camshaft is supported by four plain type bearings and is chain driven. Motion from the camshaft is transmitted to the valves by hydraulic lifters, pushrods, and ball type rocker arms. The valve guides are integral in the cylinder head.

The connecting rods are forged steel, with precision insert type crankpin bearings. The piston pins are a press fit in the connecting rods.

The pistons are cast aluminum alloy. The piston pins are a floating fit in the piston.

ENGINE LUBRICATION

Lubrication schematics are shown on the first figures. The gear type oil pump is driven from the distributor shaft, which is gear driven from the camshaft. Oil is drawn into the oil pump through a pickup screen and pipe.

Pressurized oil is routed to the oil filter. In case of excessive oil pressure, a bypass valve is provided. Filtered oil flows through the engine oil cooler (on Sportpac models) into the main gallery and then to the camshaft and crankshaft bearings. The valve lifter oil gallery supplies oil to the valve lifters. Oil flows from the hydraulic lifters through the hollow pushrods to the rocker arms. Oil from the overhead drains back to the crankcase through oil drain holes.

The timing chain is drop fed from the front camshaft bearing. The piston and piston pins are lubricated by oil splash.

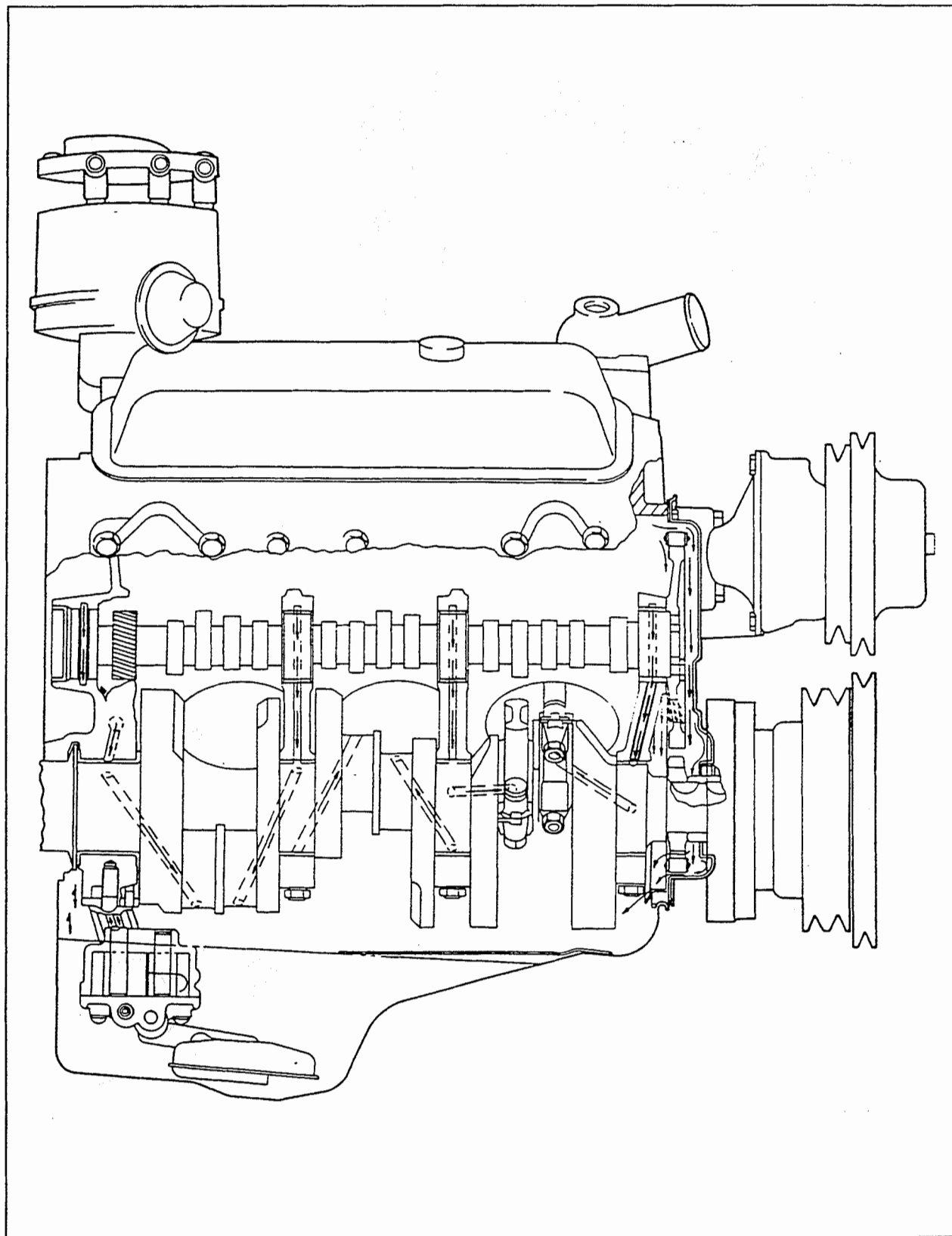

Engine Lubrication Diagram

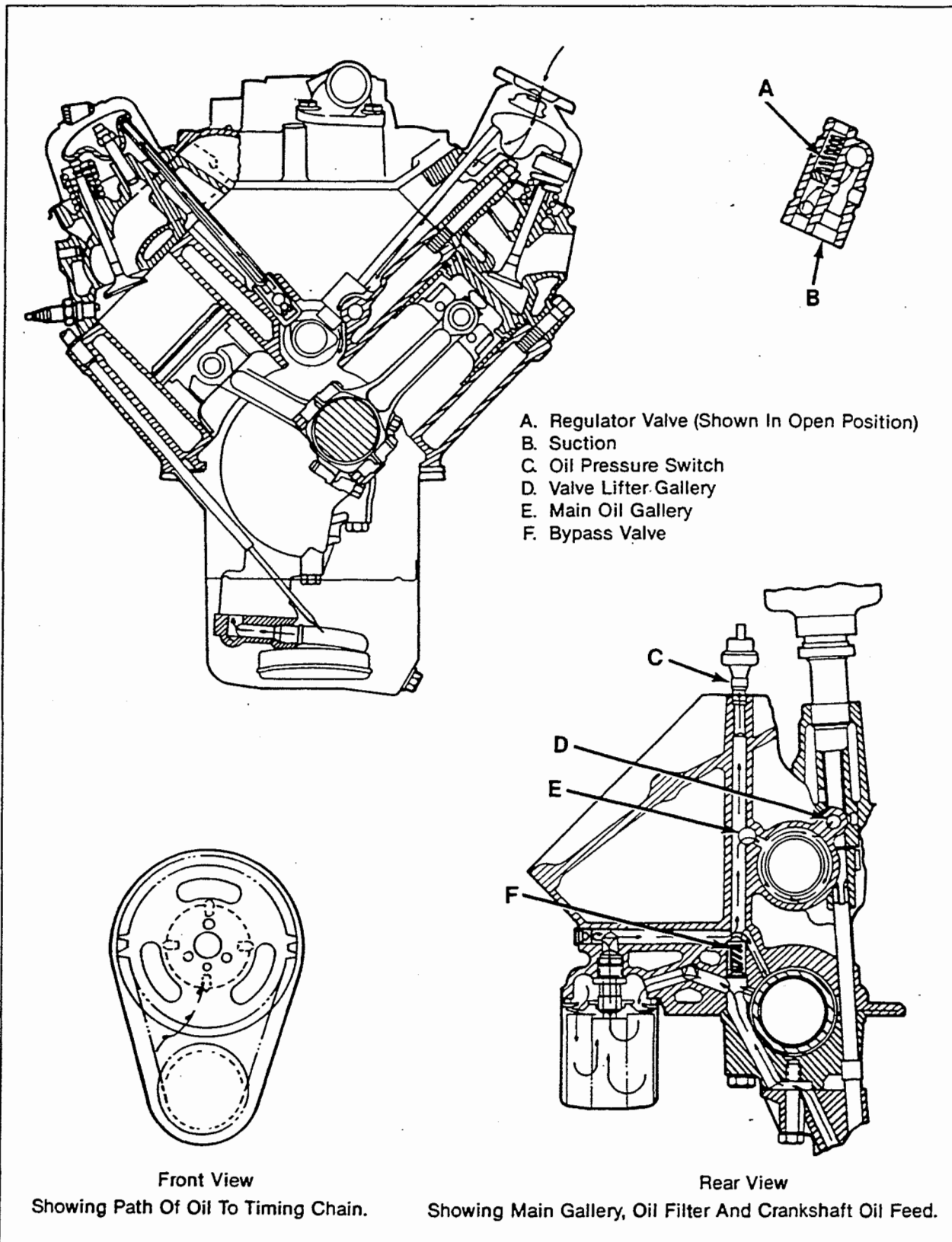

Engine Lubrication Diagram

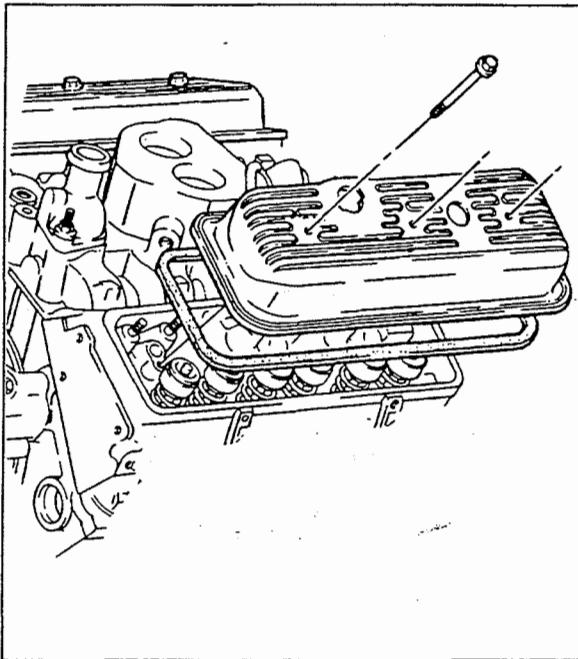
ROCKER ARM COVER REPLACEMENT**Rocker Arm Cover****Remove or Disconnect:**

1. Battery negative cable.
2. Components as follows (if necessary):
 - Exhaust riser
 - Map sensor bracket
 - Electrical component bracket
 - Fresh water cooling hoses (*It may be necessary to partially drain system by removing plugs from bottom of exhaust manifolds. See "Cooling Systems" section in this manual.*)
3. Wiring harnesses from brackets, and move aside.
4. Rocker arm cover bolts.
5. Rocker arm cover and gasket.

Clean:

- All traces of old gasket from the rocker arm cover and cylinder head.

Inspect:

- Rocker arm cover sealing surface for distortion and damage, replace if necessary.

Install or Connect:

1. Rocker arm cover and gasket.
2. Rocker arm cover bolts and washers.

Tighten:

- Rocker arm cover bolts to 11.3 N•m (100 in.lbs.)
3. Components as follows (if removed):
 - Fresh water cooling hoses
 - Electrical component brackets
 - Map sensor bracket
 - Exhaust riser
 4. Crankcase ventilation hoses.
 5. Battery negative cable.

ROCKER ARM AND PUSHROD REPLACEMENT**Remove or Disconnect:**

1. Rocker arm cover, as outlined previously.
2. Rocker arm nut.
 - If only the pushrod is to be replaced, back the rocker arm nut off until the rocker arm can be swung away from the pushrod. Then pull the pushrod out.
3. Rocker arm with ball.
4. Pushrod.

IMPORTANT! Store used components in order so they can be reassembled in the same location.

Inspect:

- Rocker arms and balls at their mating surfaces. These surfaces should be smooth and free from scoring or other damage.
- Rocker arm areas which contact the valve stems and the sockets which contact the pushrods. These areas should be smooth and free of damage and wear.

ROCKER ARM AND PUSHROD REPLACEMENT (Continued)

- Pushrods for bending. Roll the pushrod on a flat surface to determine if it is bent. Replace if necessary.
- Ends of the pushrods for scoring or roughness.

Install or Connect:

1. Pushrod. Make sure the pushrod seats properly in the hydraulic lifter.
2. Rocker arm with ball.

IMPORTANT! When new rocker arms and/or balls are installed, coat their bearing surfaces with "Molykote" or equivalent.

3. Rocker arm nuts.

Tighten:

- Nut to 27-34 N·m (20-25 ft.lbs.)

4. Rocker arm cover, as outlined previously.

VALVE STEM SEAL AND VALVE SPRING REPLACEMENT

Tools required:

- J-23590 Air Adapter
- J-5892-B Spring Compressor

1. Rocker arm cover, as outlined previously.
2. Rocker arms, as outlined previously.
3. Spark plugs.
4. Valve keepers.
 - Install J-23590 into the spark plug hole.
 - Apply compressed air to hold the valves in place.
 - Install a rocker arm nut.
 - Use J-5892-B to compress the valve spring.
 - Remove the valve keepers.
 - Carefully release the spring tension. Remove J-5892-B.

- | | |
|-----------------|-------------------|
| 1. Valve Keeper | 7. Spring |
| 2. Cap | 8. Intake Valve |
| 3. Shield | 9. Rotator |
| 4. O-Ring Seal | 10. Exhaust Valve |
| 5. Seal | |
| 6. Damper | |

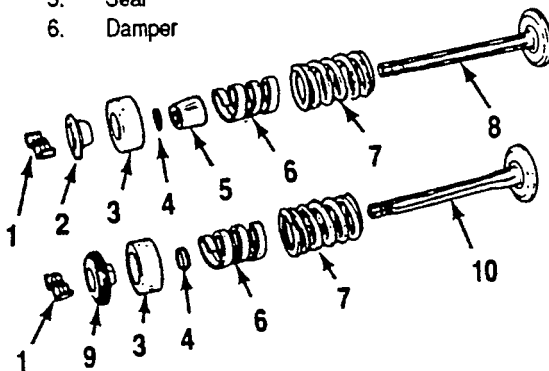

Valves and Components

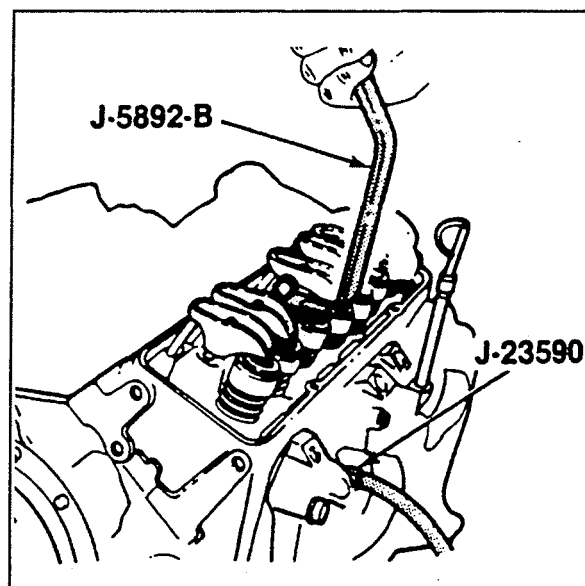

Compressing the Valve Springs

5. Cap and/or rotator, shield and spring with damper.
6. O-ring seal and seal (intake valve only).

Install or Connect:

Tools required:

- J-23590 Air Adapter
- J-5892-B Spring Compressor
- J-23738-A Vacuum Pump

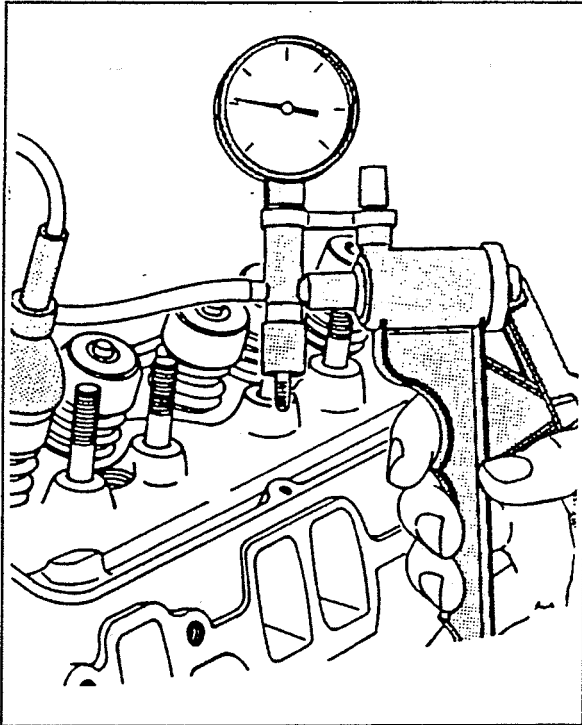

Testing the Valve Seats

1. New seal (intake valve only). Install the seal over the intake valve stem and seat it against the head.
2. Spring with damper, shield and cap and/or rotator.
3. New O-ring seal and valve keepers.
 - With air pressure applied to the cylinder with J-23590, compress the spring with J-5892-B.
 - Lubricate the O-ring seal with engine oil. Install the seal on the valve stem. Make sure the seal is not twisted.
 - Install the valve keepers. Use grease to hold them in place.
 - Carefully release spring pressure. Make sure the valve keepers stay in place.
 - Remove J-5892-B and J-23590.
 - Check each O-ring seal for leakage.
 - Place the suction cup furnished with J-23738-A over the shield.
 - Connect J-23738-A to the suction cup and apply a vacuum. Watch the vacuum pump gauge. No air should be able to leak past the seal. If the seal will not hold a vacuum, it may have been damaged or improperly installed.
4. Spark plugs.
5. Rocker arms, as outlined previously.
6. Rocker arm cover, as outlined previously.

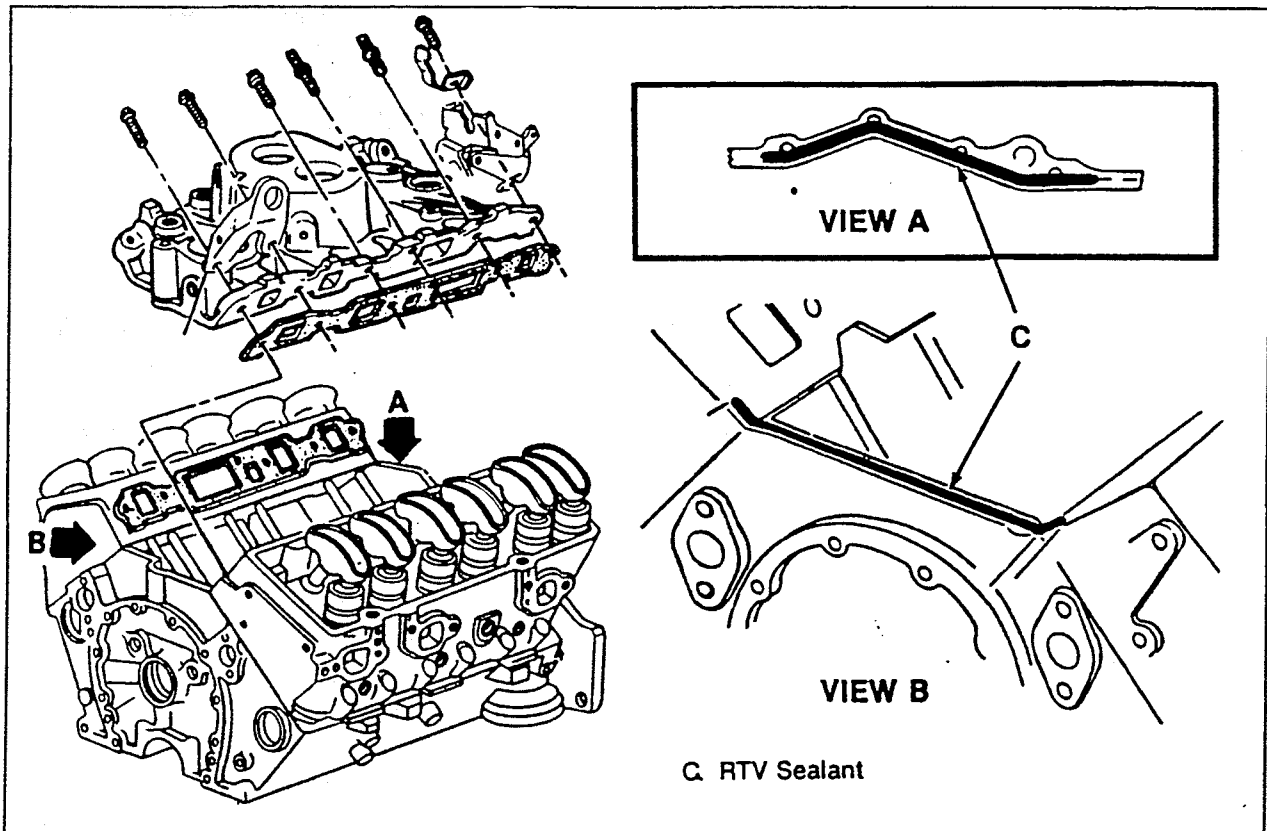

Intake Manifold

INTAKE MANIFOLD REPLACEMENT

Remove or Disconnect:

1. Battery negative cable.
2. Flame arrestor and weather cover. *Drain the cooling system. (See "Cooling Systems" section in this manual.)*
3. Distributor. *(See "Engine Electrical" section in this manual.)*
4. Cooling hoses.
5. Fuel lines.
6. Coil wires.
5. Components as follows (if equipped):
 - Carburetor
 - MAP sensor bracket
 - Electrical component bracket
 - TBI unit
6. Intake manifold bolts.
7. Intake manifold and gaskets.

Clean:

- Old gasket and RTV from the block, heads, and intake manifold. Remove all RTV that is loose or will cause interference at assembly.
- Excessive carbon deposits from the exhaust and EGR passages.
- Excessive scale and deposits from the coolant passages.

Inspect:

- Manifold for cracks and gasket surface damage.

Install or Connect:

1. Gaskets to the cylinder head.
2. RTV to the front and rear sealing surfaces on the block (see above figure). Apply a 5 mm (3/16") bead of RTV to the front and rear of the block as shown. Extend the bead 13 mm (1/2") up each cylinder head to seal and retain the gaskets.
3. Intake manifold to the engine.
4. Intake manifold bolts.

Tighten:

- Intake manifold bolts to 48 N•m (35 ft.lbs.).

Use the tightening sequence shown below.

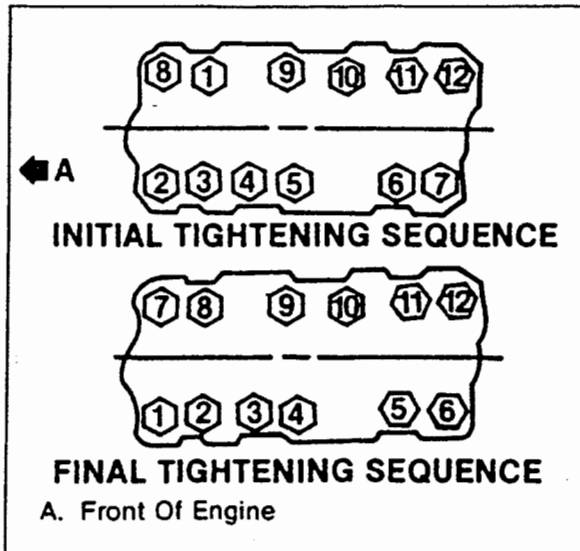
**Intake Manifold Bolt Tightening Sequence**

- Components as follows (if removed):
 - Carburetor
 - MAP sensor bracket
 - Electrical component bracket
 - TBI unit
- Coil wires.
- Fuel lines.
- Cooling hoses.
- Distributor. (See "Engine Electrical" section in this manual.)
- Flame arrestor and weather cover.
- Battery negative cable.
 - Fill the cooling system with the proper coolant (See "Cooling Systems" section in this manual.)

HYDRAULIC LIFTER REPLACEMENT**Tools required:**

- J-3049 Hydraulic Lifter Remover (Plier Type)
- J-9290-01 Hydraulic Lifter Remover (Slide Hammer)

Remove or Disconnect:

- Rocker arm cover, intake manifold and pushrods, as outlined previously.
- Bolts.
- Retainer with restrictors.
- Hydraulic lifters.
 - Remove the hydraulic lifters one at a time and place them in an organizer rack. The lifters must be installed in the same bore from which they were removed.
 - A stuck lifter can be removed using (J-3049 or J-9290-01).

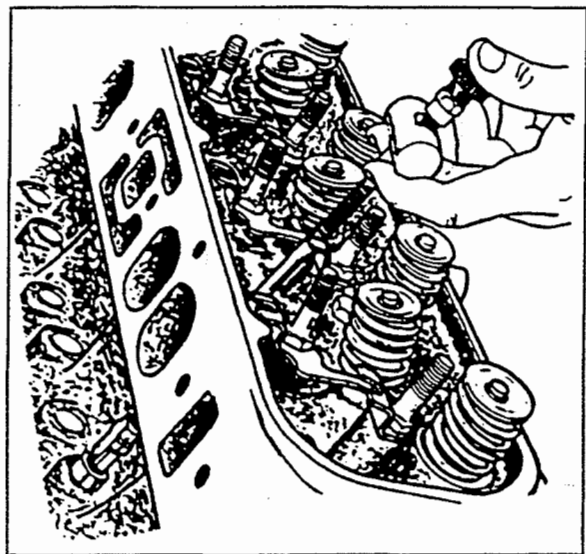
**Removing the Hydraulic Lifter (Typical)****Inspect:**

- Hydraulic lifter body for scuffing or scoring. If the lifter body wall is worn or damaged, the mating bore in the block should also be checked.
- Check the fit of each hydraulic lifter in its mating bore in the block. If the clearance is excessive, try a new lifter.
- Roller for freedom of movement.
- Roller for flat spots, pits and missing or broken needle bearings. If worn, pitted, or damaged, the mating camshaft lobe should also be checked.

Install or Connect:

- Hydraulic lifters in the block. Lubricate the lifter roller and body with Engine Oil Supplement or equivalent.

IMPORTANT! When any new hydraulic lifter or new camshaft is installed, change the engine oil and filter. Engine Oil Supplement (or equivalent) should be added to the engine oil. Replace all hydraulic lifters when a new camshaft is installed.



Removing the Hydraulic Lifter

2. Retainer with restrictors.
3. Bolts.

Tighten:

- Bolts to 16.4 N•m (145 in.lbs.)

4. Intake manifold, as outlined previously.
5. Pushrod, as outlined previously.
6. Rocker arm cover, as outlined previously.

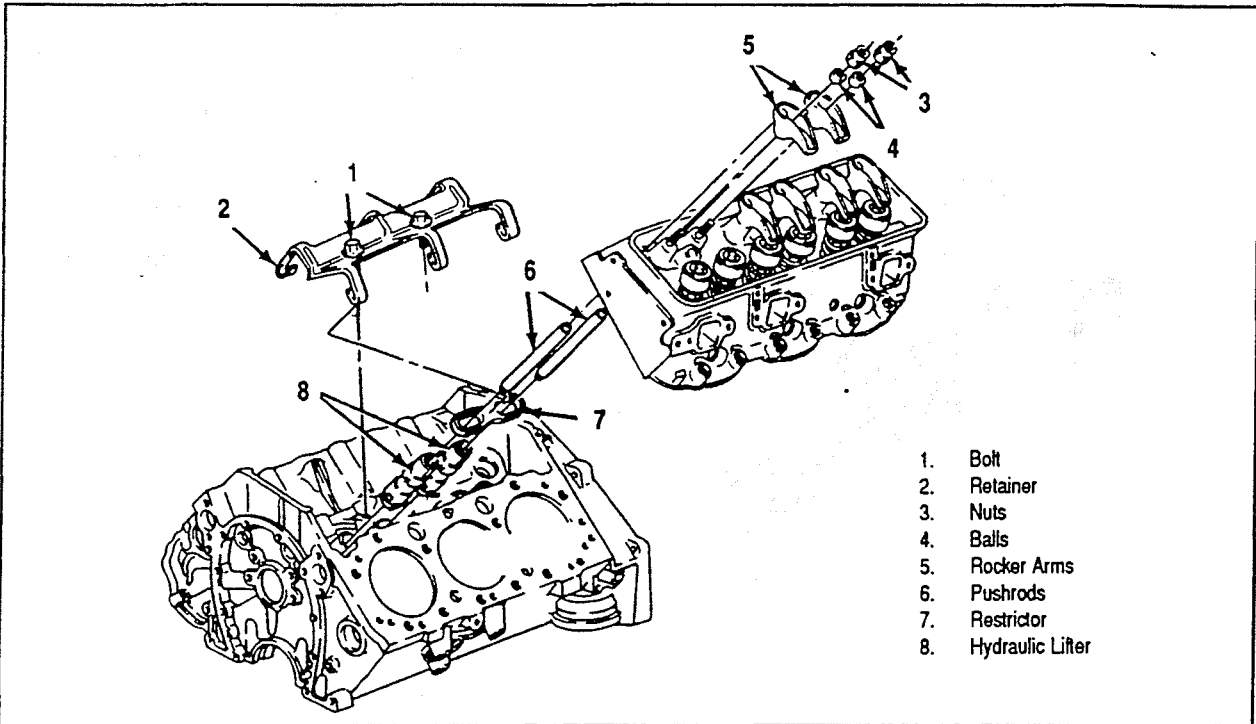

Hydraulic Lifters and Components

ROCKER ARM STUD REPLACEMENT

Tool required:

J-5802-01 Rocker Arm Stud Remover

1. Rocker arm cover and rocker arm, as outlined previously.
2. Rocker arm stud.
 - Place J-5802-01 over the rocker arm stud.
 - Install a nut and flat washer.
 - Turn the nut to remove the stud.

Install or Connect:

Tools required:

J-5715 Reamer (0.003-inch oversize) or

J-6036 Reamer (0.013-inch oversize)

J-6880 Rocker Arm Stud Installer

- Ream the hole to the proper size for the replacement oversize rocker arm stud. Use J-5715 for 0.003-inch oversize studs; J-6036 for 0.013-inch oversize stud (see figure below).

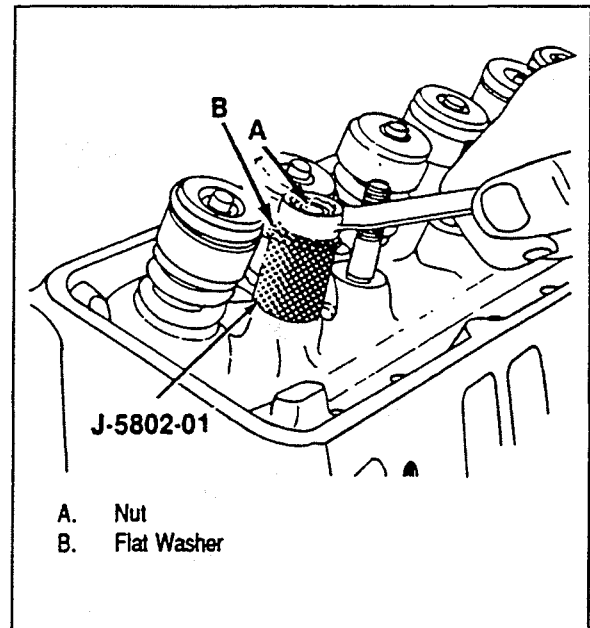

Removing the Rocker Arm Stud

- Coat the lower end (press-fit area) of the rocker arm stud with the hypoid axle lubricant.

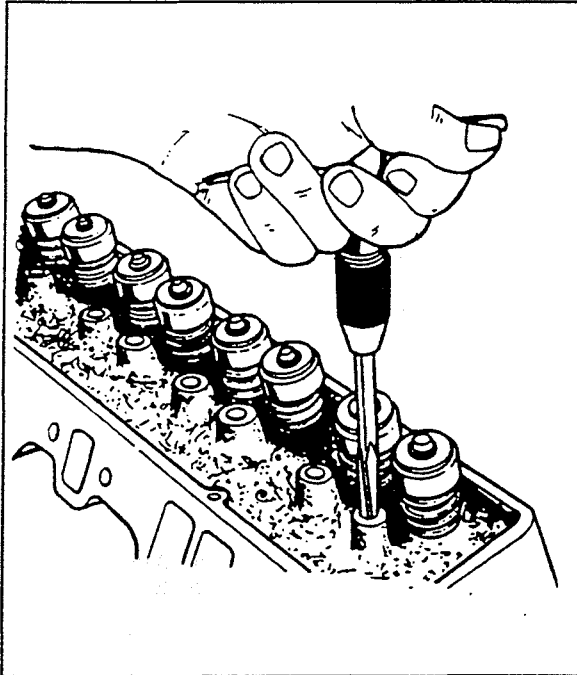

Reaming the Rocker Arm Stud Bore (Typical)

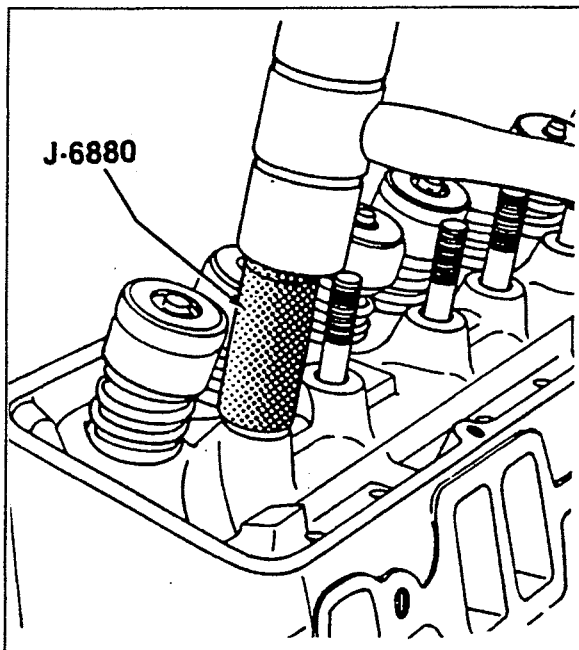

Installing the Rocker Arm Stud

NOTICE: Do not attempt to install an oversize rocker arm stud without reaming the stud hole as this could damage the cylinder head.

1. Rocker arm stud. Use J-6880. Stud is installed to proper depth when the tool bottoms on the cylinder head.
2. Rocker arm, as outlined previously.
3. Rocker arm cover, as outlined previously.

EXHAUST MANIFOLD REPLACEMENT

Remove or Disconnect:

1. Battery negative cable.
2. Coolant (See "Cooling Systems" section in this manual.)
3. Exhaust hose at the manifold and riser.
4. Exhaust manifold bolts and lockwashers, if equipped.
5. Exhaust manifold.

IMPORTANT! New engines are assembled with Permatex® sealant instead of gaskets. Unless mating surfaces are like new, gaskets should be used when replacing the manifold.

Clean:

- Mating surfaces on the manifold and head.
- Threads on the exhaust manifold bolts.

Install or Connect:

1. Exhaust manifold, bolts, washers, heat shield (left side manifold), and tab washers.

Tighten:

- Bolts on center exhaust tube to 36 N•m (26 ft.lbs.).
 - Bolts on front and rear exhaust tubes to 28 N•m (20 ft.lbs.).
 - Bend the tab washers over the heads of all bolts.
2. Exhaust hose to the manifold.
 3. Coolant (See "Cooling Systems") section in this manual).
 4. Battery negative cable.

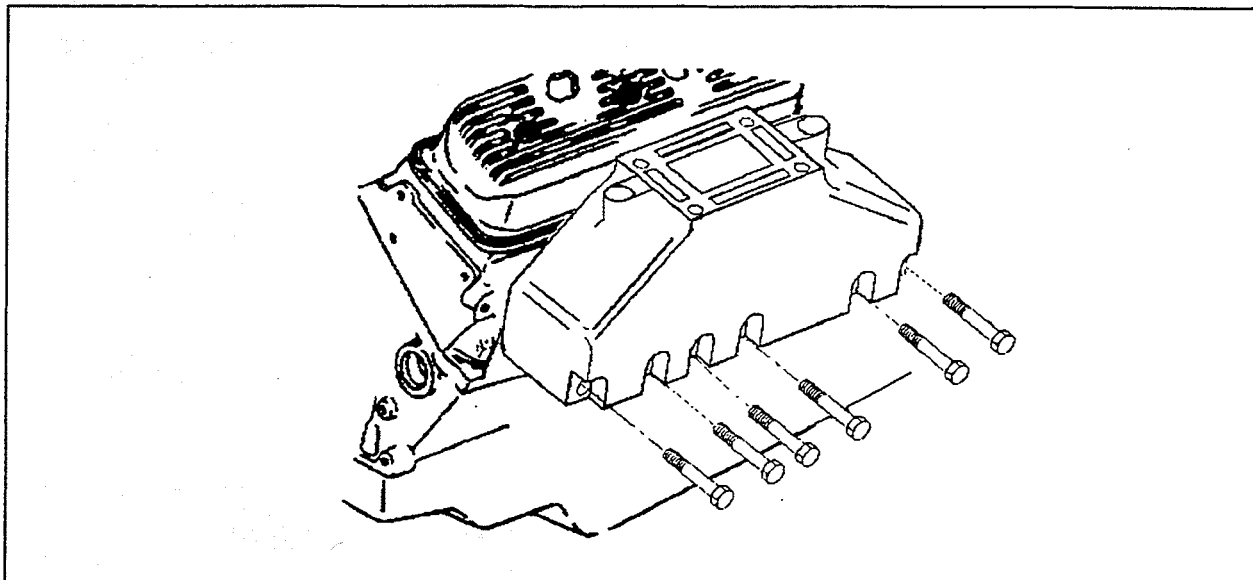

Exhaust Manifold

EXHAUST MANIFOLD RISER REPLACEMENT

Remove or Disconnect:

1. Battery negative cable.
2. Coolant from exhaust manifold. (See "Cooling Systems" section in this manual.)
3. Unbolt electric fuel pump bracket and move to the side (starboard bank only).
4. Exhaust hose.
5. Riser bolts and lockwashers.
6. Riser.

Clean:

- Mating surfaces on the manifold and riser. NOTE: In some cases, sealant was used during original assembly. Gaskets currently available do not require sealant but surfaces must be well cleaned.
- Threads on the riser bolts.

Install or Connect:

1. Riser to exhaust manifold with new gasket.
2. Electric fuel pump bracket (starboard bank only).
3. Riser bolts and lockwashers.

Tighten:

- Diagonally opposite riser bolts to 34 N•m (25 ft.lbs.)
- Remaining two riser bolts to 34 N•m (25 ft.lbs.).

4. Exhaust hose.
5. Coolant. (See "Cooling Systems" section in this manual.)
6. Battery negative cable.

CYLINDER HEAD REPLACEMENT

Remove or Disconnect:

1. Battery negative cable.
2. Intake manifold, as outlined previously.
3. Exhaust manifold, as described previously.
4. Components as follows (if necessary):
 - Alternator bracket
 - Fresh water cooling tank bracket(s)
 - Fuel/water separator
 - Electric fuel pump
5. Spark plug wires at the brackets.
6. Rocker arm cover, as outlined previously.
7. Spark plugs.

CYLINDER HEAD REPLACEMENT (Continued)

8. Pushrods, as outlined previously.
9. Cylinder head bolts.
10. Cylinder head.
11. Gasket.

Clean:

- Carbon deposits from combustion chambers.
- All traces of old head gasket from cylinder head and block.
- Cylinder head bolt threads and threads in the block.

Inspect:

- Sealing surfaces of the block and cylinder head for nicks, heavy scratches or other damage.

Install or Connect:

1. Head gasket.
 - Place the gasket over the block dowel pins with the bead up.
2. Cylinder head. Carefully guide the cylinder head into place over the dowel pins and gasket.
3. Cylinder head bolts. Coat threads of the cylinder head bolts with sealing compound such as Permatex® and install finger-tight.

Tighten:

- Cylinder head bolts, a little a time, using the sequence shown in next figure. Proper torque is 90 N·m (65 ft.lbs.).
4. Pushrods, as outlined previously.
 5. Rocker arm cover, as outlined previously.
 6. Spark plugs.
 7. Spark plug wires.
 8. Components as follows (if removed):
 - Alternator
 - Fresh water cooling tank bracket(s)
 - Fuel/water separator
 - Electric fuel pump
 9. Exhaust manifold, as outlined previously.
 10. Intake manifold, as outlined previously.
 11. Battery negative cable
 - Fill cooling system (See "Cooling System" section in this manual.)

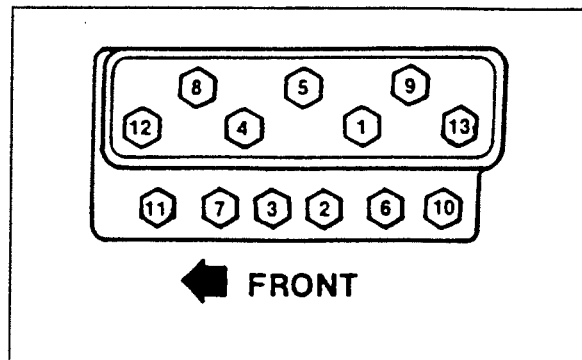
**Cylinder Head Bolt Tightening Sequence****TORSIONAL DAMPER AND FRONT CRANKSHAFT SEAL REPLACEMENT****Remove or Disconnect:**

Tool required:

J-23523-E Torsional Damper Puller and Installer

1. Seawater pump bracket (if equipped).
2. Alternator belt(s) and crankshaft pulley (if equipped).
3. Torsional damper bolt.
4. Torsional damper. Use J-23523-E.
5. Front crankshaft seal. Pry out with a large screwdriver. Take care not to distort the timing cover.
6. Crankshaft key, if necessary.

Inspect:

- Oil seal contact area on the torsional damper shaft for grooving and roughness. Replace if necessary.

Install or Connect:

Tools required:

J-35468 Seal Installer

J-23523-E Torsional Damper Puller and Installer

1. Crankshaft key, if removed.

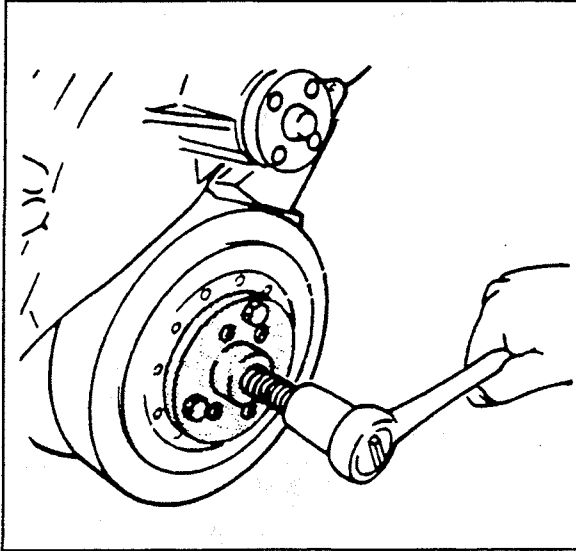

Removing the Torsional Damper

2. Front crankshaft seal. Use J-35468. The open end of the seal faces inside the engine. Coat the seal lips with engine oil.
3. Stud (item A in figure above) to the crankshaft. Thread the stud fully into the tapped hole in the crankshaft.

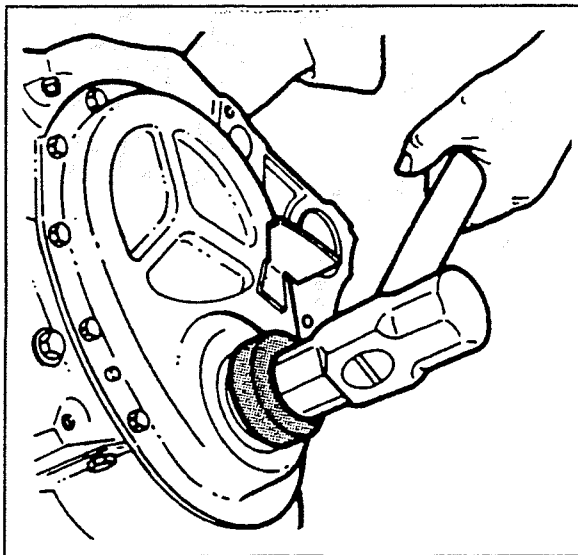

Installing the Front Crankshaft Oil Seal

4. Torsional damper over the end of the stud. Align the keyway in the torsional damper shaft with the crankshaft key.
5. Bearing, washer and nut.
 - Turn the nut to pull the vibration damper into place.

- Remove the tool.
 - Use a small amount of RTV sealant to seal the torsional damper key to crankshaft joint.
6. Torsional damper bolt and washer.

Tighten:

- Bolt to 95 N•m (70 ft.lbs.)

7. Crankshaft pulley and alternator fan belts.

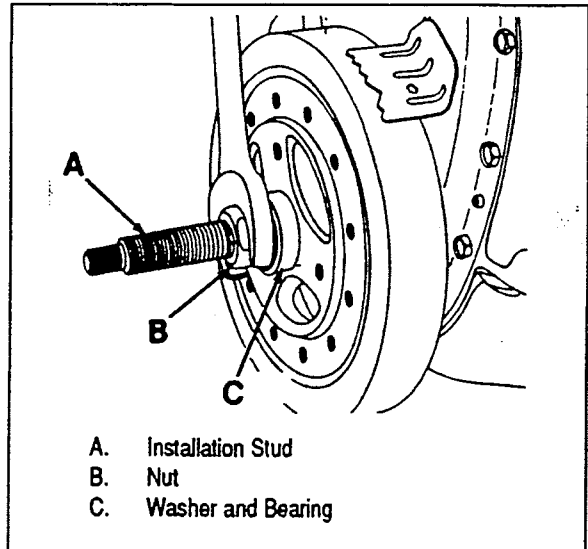

Installing the Torsional Damper

NOTICE: The inertia weight section of the torsional damper is assembled to the hub with a rubber type material. The correct installation procedures (with the proper tool) must be followed or movement of the inertia weight section of the hub will destroy the tuning of the torsional damper.

FRONT COVER REPLACEMENT

Remove or Disconnect:

1. Torsional damper, as outlined previously.
2. Water pump. (See "Cooling Systems" section in this manual.)
3. Oil pan, as outlined later.
4. Front cover bolts.
5. Front cover.
6. Front cover to block gasket.

FRONT COVER REPLACEMENT (Continued)

7. Front crankshaft oil seal from the front cover. Pry out with a screwdriver. Take care not to distort the front cover.

Clean:

- Old gasket from the front cover and block.

Inspect:

- Front cover for distortion and damage. Replace if necessary.

Install or Connect:

Tool required:
J-35468 Seal Installer

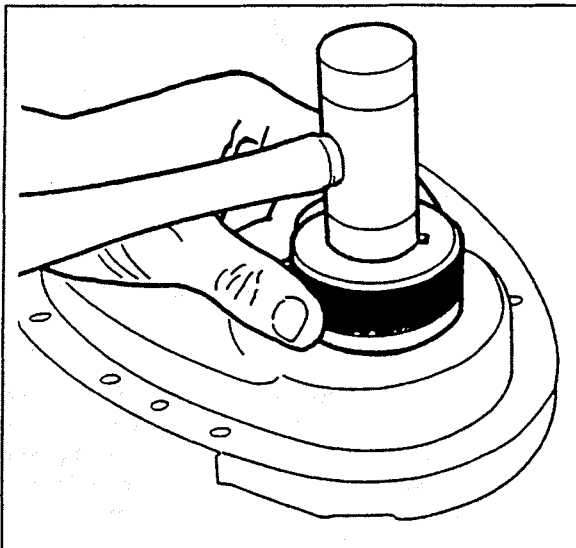

Installing the Front Crankshaft Oil Seal

1. Front crankshaft oil seal. Use J-35468. The open end of the seal faces inside the engine. Coat the seal lips with engine oil.
2. Front cover gasket to the front cover. Use gasket cement to hold them in place.
3. Front cover and bolts.

Tighten:

- Front cover bolts to 11.3 N•m (100 in.lbs.)

4. Oil pan, as outlined later.
5. Water pump. (See "Cooling Systems" section in this manual.)

6. Torsional damper, as outlined previously.

OIL PAN REPLACEMENT

A one piece type oil pan gasket is used.

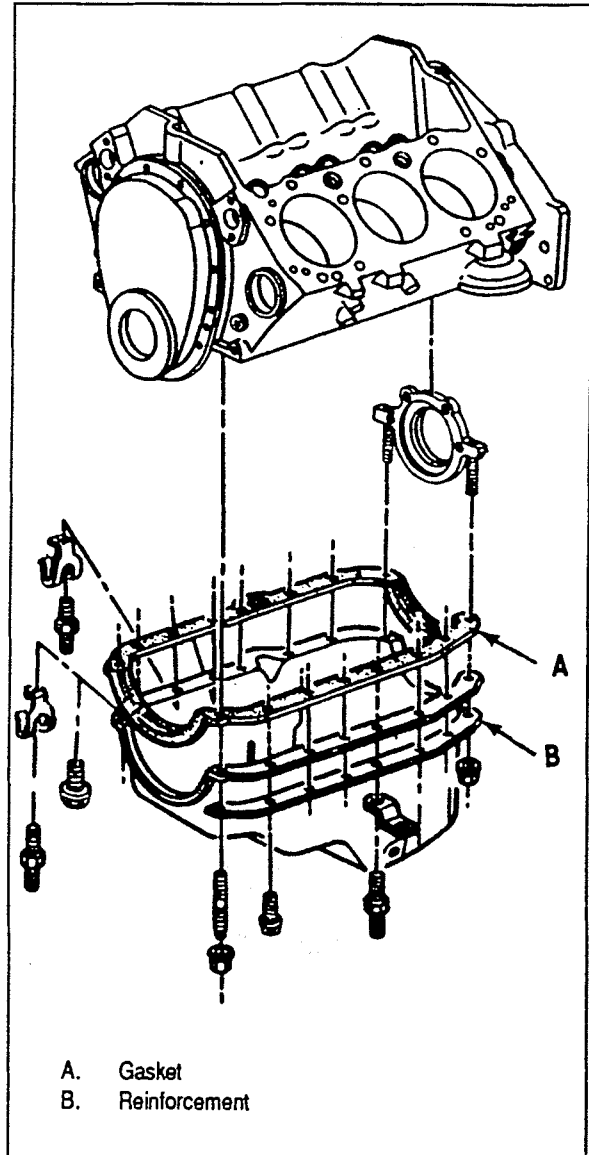

Oil Pan

- A. Gasket
- B. Reinforcement

Remove or Disconnect:

1. Battery negative cable.

OIL PAN REPLACEMENT (Continued)

- Raise the engine if necessary. (In some cases, it may be necessary to remove engine from boat.)
 - Drain the engine oil.
2. Starter. (Bottom mount starters only.)
 3. Oil pan bolts, nuts and reinforcements.
 4. Oil pan and gasket.

Clean:

- Gasket surfaces on the engine and oil pan.

Inspect:

- Oil pan gasket for damage. Replace if necessary.

Install or Connect:

- Apply sealant to the front cover to block joint and to the rear crankshaft seal to block joint. Apply the sealant for about 25 mm (1") in both directions from each of the four corners.

1. Oil pan gasket to the oil pan.
2. Oil pan to the engine.
3. Oil pan bolts, nuts and reinforcements.

Tighten:

- Oil pan bolts to 11.3 N•m (100 in.lbs.)
- Oil pan nuts at corners to 22.6 N•m (200 in.lbs.)

4. Starter. (Bottom mount starters only.)
5. Lower engine if necessary.
6. Proper quantity and grade of engine oil.
7. Battery negative cable.

OIL PUMP REPLACEMENT**Remove or Disconnect:**

1. Oil pan, as outlined previously.
2. Oil pump to main bearing cap bolt.
3. Oil pump.

Inspect:

- Oil pump pickup tube for looseness. If the tube is

loose in the oil pump body, replace it, as outlined in the proper unit repair manual. A loose pickup tube can result in an air leak and loss of oil pressure.

Install or Connect:

1. Oil pump to the engine. Align the slot in the oil pump shaft with the tang on the distributor shaft. The oil pump should slide easily into place. No gasket is used.
2. Oil pump to main bearing cap bolt.
3. Oil pan, as outlined previously.

Tighten:

- Oil pump to main bearing cap bolt to 90 N•m (65 ft.lbs.)

REAR CRANKSHAFT OIL SEAL REPLACEMENT**Remove or Disconnect:**

1. Transmission (if equipped).
2. Damper and flywheel or flexplate, as equipped.

NOTICE: Care should be taken when removing the rear crankshaft oil seal so as not to nick the crankshaft sealing surface.

3. Rear crankshaft oil seal. Insert a screwdriver into the notches provided in the seal retainer and pry the seal out (as shown in figure below). Take care not to damage the crankshaft sealing surface.

Inspect:

- Chamfer on crankshaft for grit, loose rust and burrs. Correct as necessary.

Clean:

- Seal running surface on the crankshaft with a non-abrasive cleaner.

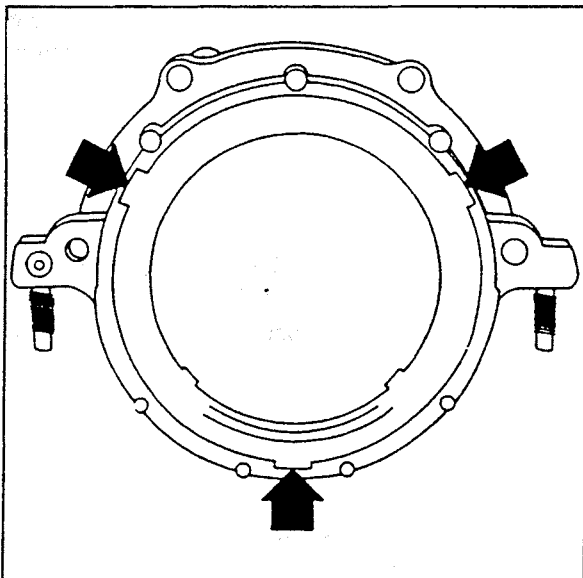

Seal Removal Notches

Install or Connect:

Tool required:
J-35621 Seal Installer

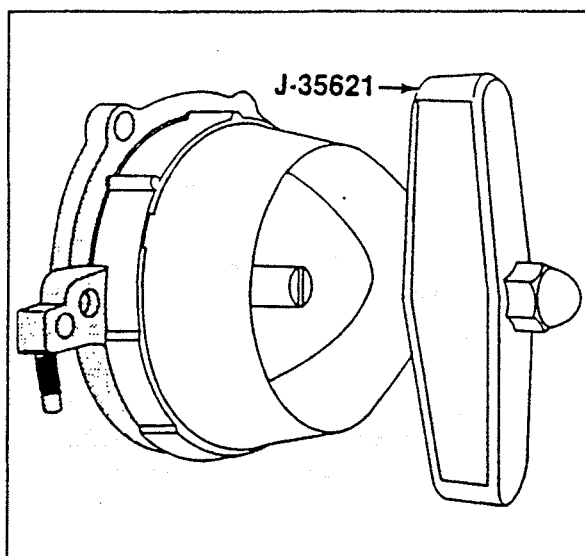

Installing the Rear Crankshaft Oil Seal

1. Rear crankshaft oil seal (as shown in next figure).
 - Lubricate the inner and outer diameter of the seal with engine oil.
 - Install the seal on J-35621.
 - Position J-35621 against the crankshaft. Thread the attaching screws into the tapped holes in the crankshaft.

- Tighten the screws securely with a screwdriver. This will ensure that the seal is installed squarely over the crankshaft.
 - Turn the handle until it bottoms.
 - Remove J-35621.
2. Damper and flywheel or flexplate, as equipped.
 3. Transmission (if equipped).

REAR CRANKSHAFT OIL SEAL RETAINER REPLACEMENT

Remove or Disconnect:

1. Transmission (if equipped).
2. Damper and flywheel or flexplate, as equipped.
3. Oil pan, as outlined previously.
4. Screws and nuts.
5. Seal retainer.
6. Gasket.
7. Rear crankshaft oil seal. Insert a screwdriver into the notches provided in the seal retainer and pry the seal out.

Clean:

- Gasket surfaces on block and seal retainer.

Install or Connect:

- *Whenever the seal retainer is removed, a new retainer gasket and rear crankshaft oil seal must be installed.*

1. Gasket to the block. It is not necessary to use sealant to hold the gasket in place.
2. Seal retainer.
3. Screws and nuts.

Tighten:

- Screws and nuts to 15.3 N•m (135 in.lbs.)

4. Oil pan, as outlined previously.
5. Rear crankshaft oil seal, as outlined previously.
6. Damper and flywheel or flexplate, as equipped.
7. Transmission (if equipped).

MEASURING CAMSHAFT LOBE LIFT

Tool required:

J-8520 Camshaft Lobe Lift Indicator

1. Remove the rocker arm, as outlined previously.
2. Refer to next figure. Position the dial indicator (part of J-8520) so the plunger rests on the pushrod end, as shown. Make sure the pushrod is in the lifter socket.
3. Rotate the crankshaft slowly in the direction of rotation until the lifter is on the heel of the cam lobe. At this point, the pushrod will be in its lowest position.
4. Set dial indicator on zero, then rotate the crankshaft slowly, or attach an auxiliary starter switch and "bump" the engine over, until the pushrod is in fully raised position.
5. Compare the total lift recorded from the dial indicator with specifications.
6. If camshaft readings for all lobes are within specifications, remove dial indicator assembly.

IMPORTANT! Whenever the engine is cranked remotely at the starter, with a special jumper cable or other means, the distributor primary lead should be disconnected from the ignition coil.

7. Install the rocker arm and adjust the valves as previously outlined.

CAMSHAFT REPLACEMENT**Remove or Disconnect:**

Tool required:

J-5825-A Crankshaft Sprocket Puller

1. Battery negative cable.
2. Weather cover and flame arrestor.
3. Drain coolant. (See "Cooling Systems" section in this manual.)
4. Rocker arm covers, as outlined previously.
5. Water pump. (See "Cooling Systems" section in this manual.)

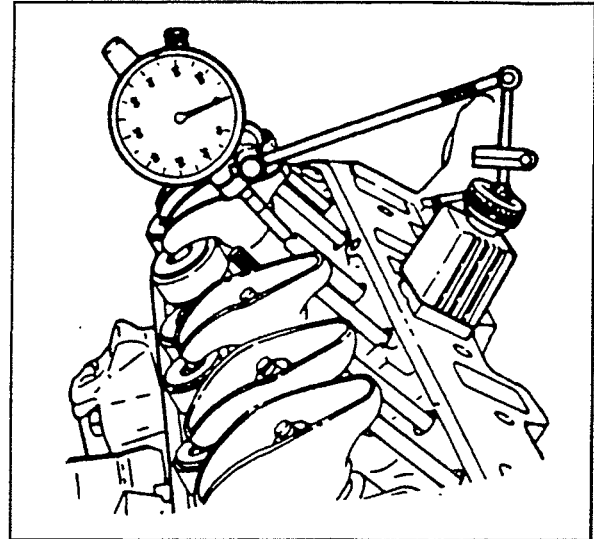

Measuring Camshaft Lobe Lift

6. Torsional damper, as outlined previously.
7. Front cover, as outlined previously.
8. Distributor. (See "Engine Electrical" section in this manual.)
9. Intake manifold, as outlined previously.
10. Pushrods and hydraulic lifters, as outlined previously.
 - Align the timing marks.
11. Camshaft sprocket bolts.
12. Camshaft sprocket and timing chain. The sprocket is a light interference fit on the camshaft. Tap the sprocket on its lower edge to loosen it.
13. Screws and thrust plate.
14. Crankshaft sprocket (if required). Use J-5825-A.
15. Engine mounting nuts if engine is to be raised or removed.
 - Raise engine if forward clearance is insufficient.
16. Camshaft.
 - Install two or three 5/16-18 bolts 100-125 mm (4-5 inches) long into the camshaft threaded holes. Use these bolts to handle the camshaft (see figure below).
 - Pull the camshaft from the block. Use care to prevent damage to the camshaft bearings.

Cleaning, Inspection and Repair:

- Clean, inspect and repair or replace the camshaft and related components.

CAMSHAFT REPLACEMENT (Continued)

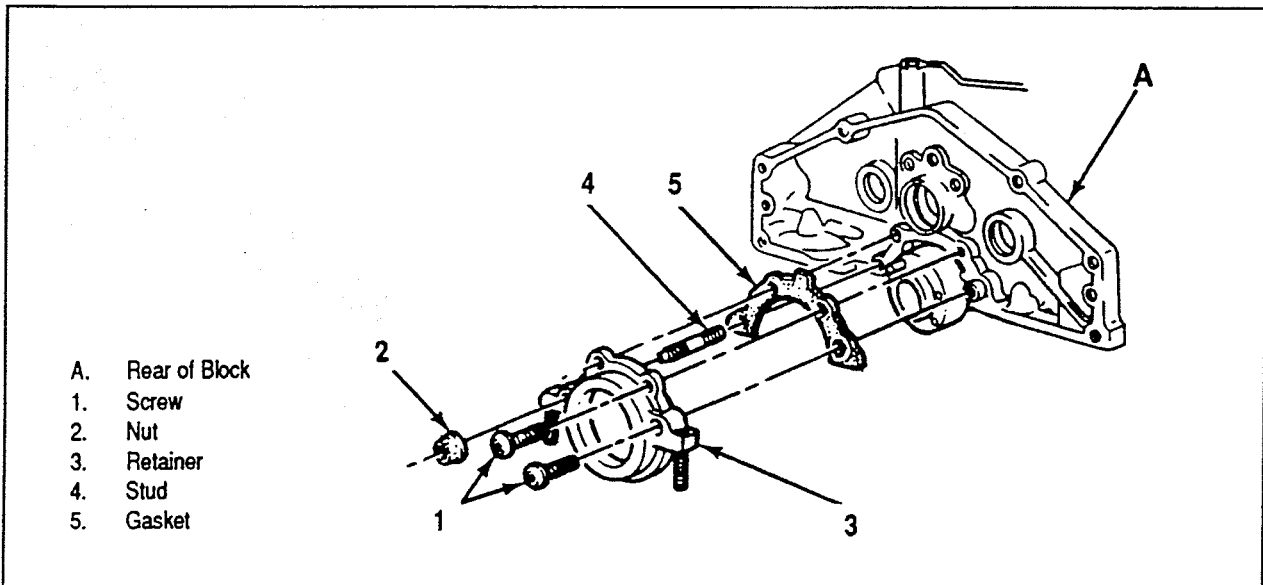

Rear Crankshaft Oil Seal Retainer

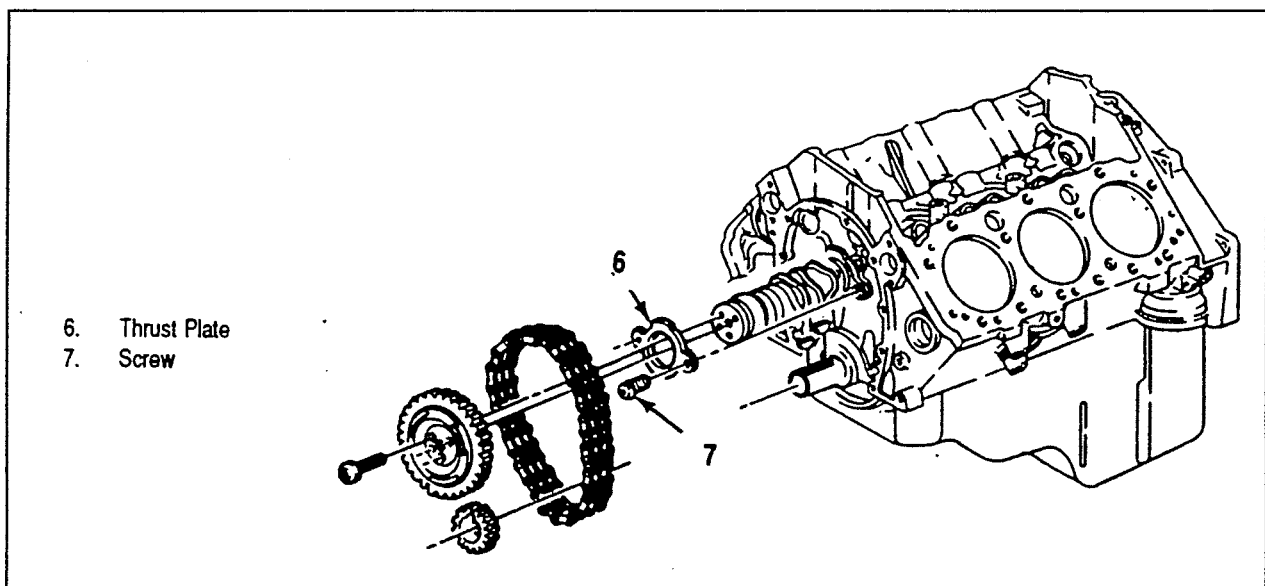

Camshaft and Components

Install or Connect:

Tool required:

J-5590 Crankshaft Sprocket Installer

- Coat the camshaft lobes and journals with a high quality engine oil supplement.

1. Two or three 5/16-18 bolts 100-125 mm (4-5 inches) long into the camshaft threaded holes. Use these bolts to handle the camshaft.
2. Camshaft to the engine (see figure below). Handle the camshaft carefully to prevent damage to the camshaft bearings.
 - Lower engine if previously raised.
 - Align engine.

CAMSHAFT REPLACEMENT (Continued)

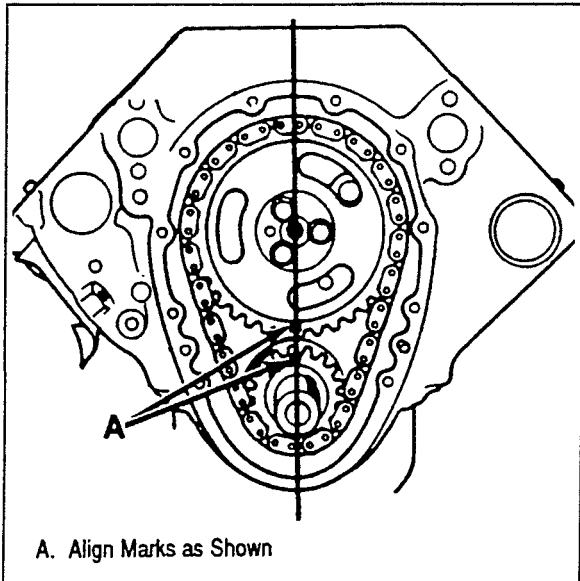

A. Align Marks as Shown

Timing Marks

3. Crankshaft sprocket (if removed). Use J-5590 (see figure below). Make sure the timing mark faces outside.
4. Thrust plate and screws.

Tighten:

- Screws to 11.9 N•m (105 in.lbs.)

5. Camshaft sprocket and timing chain.
6. Camshaft sprocket bolts.

Tighten:

- Bolts to 23 N•m (17 ft.lbs.)

IMPORTANT! Line up the timing marks on the camshaft sprocket and crankshaft sprocket.

7. Hydraulic lifters and pushrods, as outlined previously.
8. Intake manifold, as outlined previously.
9. Distributor. (See "Engine Electrical" section in this manual.)
10. Front cover, as outlined previously.
11. Torsional damper, as outlined previously.
12. Water pump.

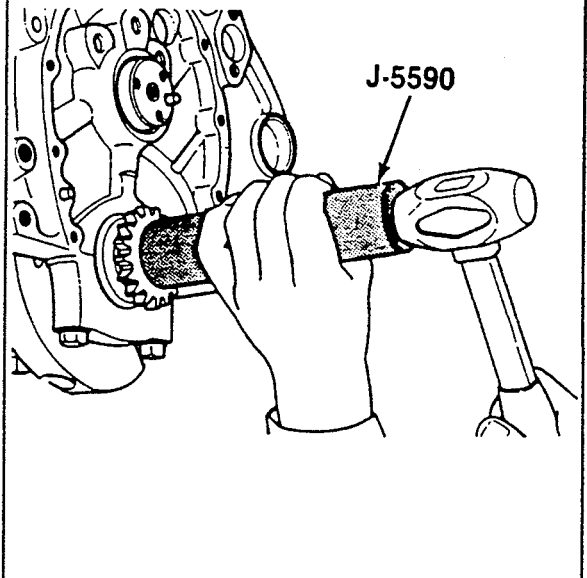
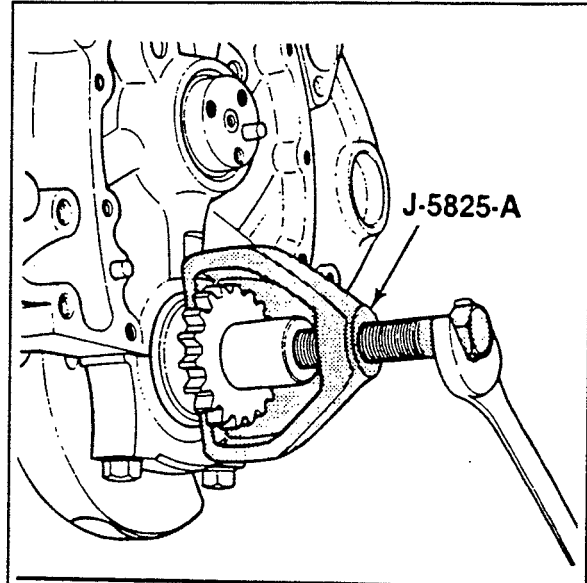

Replacing the Crankshaft Sprocket

IMPORTANT! Replace all hydraulic lifters, change the engine oil and filter, and add engine oil supplement to the engine oil whenever a new camshaft is installed.

13. Rocker arm covers, as outlined previously.
14. Flame arrestor and weather cover.
15. Battery negative cable.
 - Coolant (See "Cooling Systems" section in this manual.)

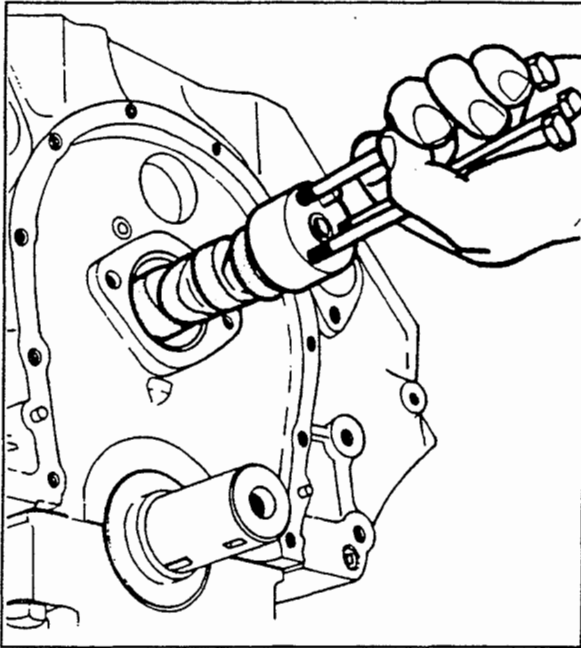
CAMSHAFT REPLACEMENT (Continued)**Replacing the Camshaft****CONNECTING ROD AND PISTON REPLACEMENT****Remove or Disconnect:**

Tool required:
J-5239 Guide Set

1. Engine from boat, as outlined later.
2. Cylinder head, as outlined previously.
3. Oil pump, as outlined previously (if necessary).
4. Ridge or deposits from the upper end of the cylinder bores.
 - Turn the crankshaft until the piston is at BDC.
 - Place a cloth on top of the piston.
 - Perform the cutting operation with a ridge reamer.
 - Turn the crankshaft until the piston is at TDC.
 - Remove the cloth and cuttings.
5. Connecting rod cap. Check the connecting rod and cap for identification marks. Mark the parts if required. The connecting rod and cap must be kept together as mating parts.

6. Connecting rod and piston.
 - Attach J-5239 to the connecting rod bolts (see next figure).
 - Use the long guide rod of J-5239 to push the connecting rod and piston out of the bore.
7. Connecting rod bearing.

Cleaning, Inspection and Repair:

- Clean, inspect and repair or replace the components as necessary. Measure connecting rod bearing clearance, piston clearance, ring clearances, etc.

Install or Connect:

Tools required:
J-5239 Connecting Rod Guide Set
J-8037 Ring Compressor

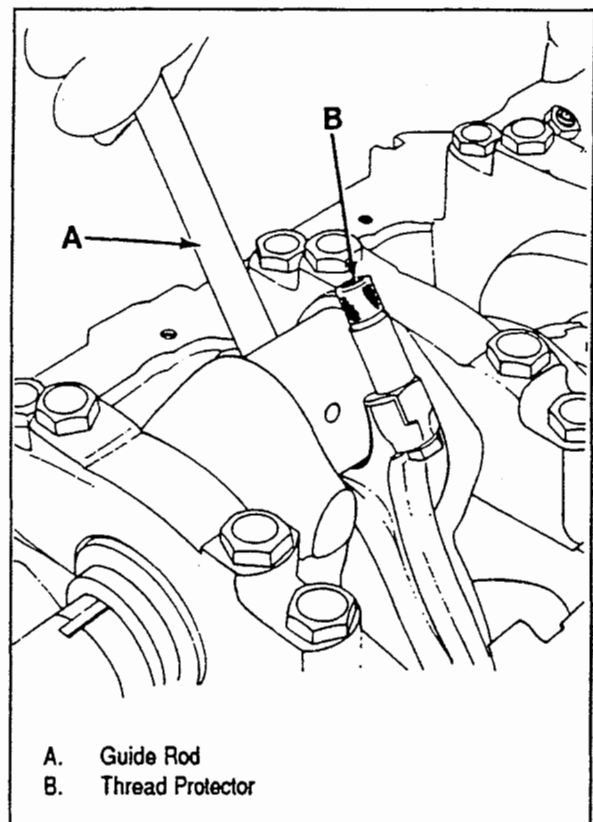
**Replacing the Connecting Rod and Piston (Typical)**

- Make sure the cylinder walls are clean. Lubricate the cylinder wall lightly with engine oil.

CONNECTING ROD AND PISTON REPLACEMENT (Continued)

- Make sure the piston is installed in the matching cylinder.
1. Connecting rod bearings.
 - Be certain that the bearing inserts are of the proper size.
 - Install the bearing inserts in the connecting rod and connecting rod cap.
 - Lubricate the bearings with engine oil.

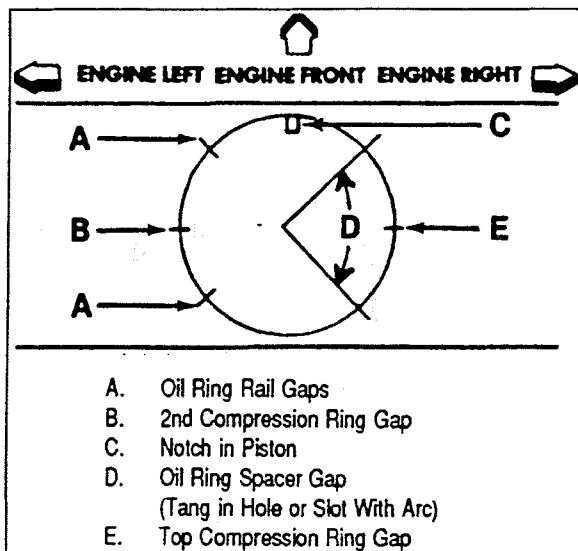

Piston Ring End Gap Locations

2. Piston and connecting rod to the proper bore.
 - With the connecting rod cap removed, install J-5239 onto the connecting rod studs.
 - Locate the piston ring end gaps as shown in figure below. Lubricate the piston and rings with engine oil.
 - Without disturbing the ring end gap location, install J-8037 over the piston (see figure below).
 - The piston must be installed so that the notch in the piston faces the front of the engine (see figure below).
 - Place the piston in its matching bore. The connecting rod bearing tang slots must be on the side opposite the camshaft. Using light blows with a hammer handle, tap the piston down into its bore (see figure below). At the same time, from beneath the engine guide the

connecting rod to the crankpin with J-5239. Hold the ring compressor against the block until all rings have entered the cylinder bore.

- Remove J-5239 from the connecting rod bolts.

IMPORTANT! Each connecting rod and bearing cap should be marked, beginning at the front of the engine. Cylinders 1, 3 and 5 are at the left bank and 2, 4 and 6 are the right bank. The numbers on the connecting rod and bearing cap must be on the same side when installed in the cylinder bore. If a connecting rod is ever transposed from one block or cylinder to another, new connecting rod bearings should be fitted and the connecting rod should be numbered to correspond with the new cylinder number.

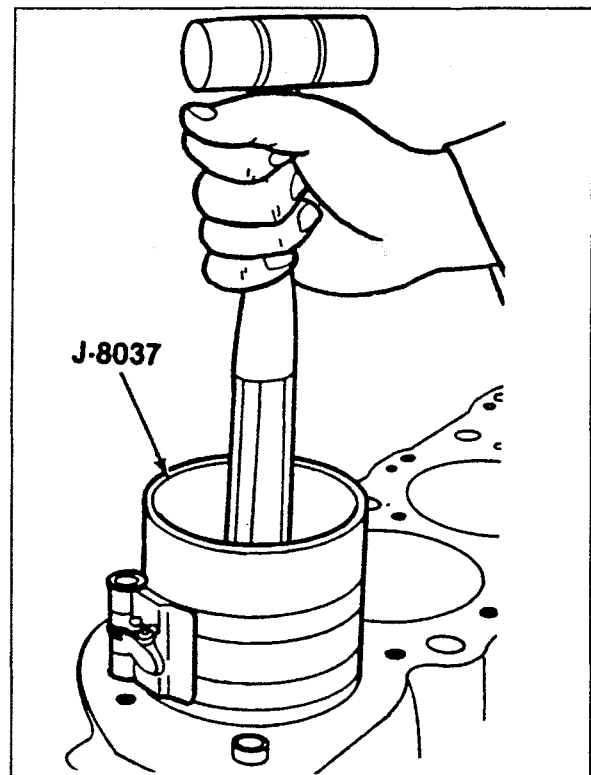

Installing the Piston

Measure:

- Connecting rod bearing clearance.
3. Connecting rod cap and bearing.
 4. Connecting rod cap nuts.

CONNECTING ROD AND PISTON REPLACEMENT (Continued)

Tighten:

- Connecting rod cap nuts to 60 N•m (45 ft.lbs.)

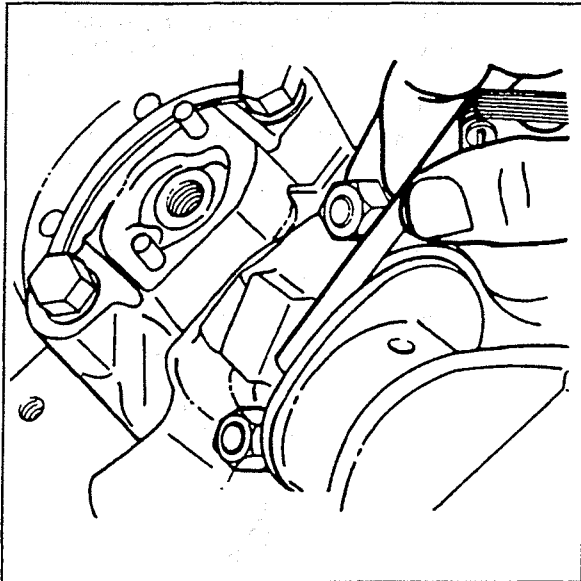

Measuring Connecting Rod Side Clearance

Measure:

- Connecting rod side clearance. Use a feeler gauge between the connecting rod and crankshaft (as shown in figure above). The correct clearance is 0.006-0.014-inch.
5. Oil pump (if removed), as outlined previously.
 6. Oil pan and cylinder head, as outlined previously.

MAIN BEARING REPLACEMENT

Remove or Disconnect:

Tool required:

J-8080 Main Bearing Remover/Installer

1. Spark plugs.
2. Oil pan, as outlined previously.
3. Oil pump, as outlined previously.
4. Main bearing caps.

- Check the main bearing caps for location markings. Mark the caps if necessary. The caps must be returned to their original locations during assembly.
5. Lower main bearing inserts from the main bearing caps.
 6. Upper main bearing inserts.
 - Insert J-8080 into the crankshaft oil hole (see following figure).
 - Rotate the crankshaft to "turn" the bearing insert out of the block.

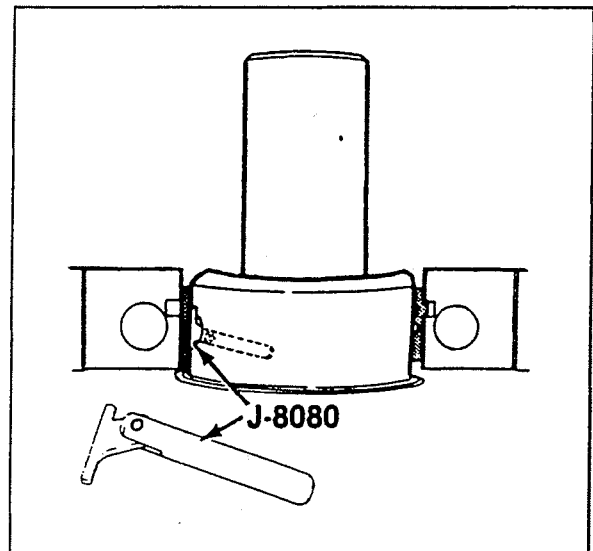

Removing the Main Bearing Insert

Cleaning, Inspection and Repair:

- Clean, inspect and repair or replace the components as required.

Install or Connect:

Tool required:

J-8080 Main Bearing Remover/Installer

1. Upper main bearing inserts.
 - Insert J-8080 into a crankshaft main bearing oil hole.
 - Apply engine oil to inserts of the proper size.
 - Insert the plain end (without the bearing tang) of the insert between the crankshaft and the notched side of the block.

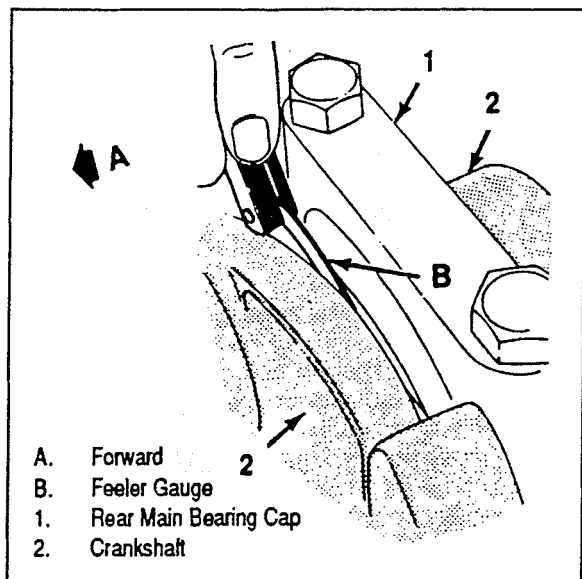
MAIN BEARING REPLACEMENT (Continued)**Measuring Crankshaft End Play**

- Rotate the crankshaft to "roll" the insert into the block.
 - Remove the tool.
- Lower main bearing inserts to the main bearing caps.
 - Make sure the inserts are of the proper size.
 - Apply engine oil to the inserts.

Measure:

- Main bearing clearance.

- Main bearing caps (except rear cap) and bolts to the block.

Tighten:

- Main bearing cap bolts to 100 N•m (75 ft.lbs.)
- Rear main bearing cap.
 - Apply engine oil to the bearing insert.
 - Install the rear main bearing cap and bolts. Tighten the bolts temporarily to 14 N•m (10 ft.lbs.).

Measure:

- Crankshaft end play, as follows:

- Tap the end of the crankshaft first rearward then forward with a lead hammer. This will line up the rear main bearing and crankshaft thrust surfaces.
- Tighten the rear main bearing cap bolts to 100 N•m (75 ft.lbs.).
- With the crankshaft forced forward measure at the front end of the rear main bearing with a feeler gauge. The proper clearance is 0.002-0.006-inch.
- If correct end play cannot be obtained, be certain that the correct size rear main bearing has been installed. Production engines may have rear main bearings that read 0.008-inch wider across the thrust faces than standard.

- Oil pump, as outlined previously.
- Oil pan, as outlined, previously.
- Spark plugs.

OIL FILTER ADAPTER AND OIL FILTER BYPASS VALVE REPLACEMENT (For models with Engine Oil Cooler)

Remove or Disconnect:

- Oil filter or remote bypass.

Inspect:

- Bypass valve spring and fiber valve for proper operation, cracks, or other damage. If replacement is required, the bypass valve and oil filter adapter must be replaced as an assembly, as outlined following.
- Oil cooler lines.
 - Bolts.
 - Oil filter adapter.
 - Gasket and seal.

Install or Connect:

- New gasket, new seal and oil filter adapter to the block.
- Bolts.

OIL FILTER ADAPTER AND OIL FILTER BYPASS VALVE REPLACEMENT (Continued)

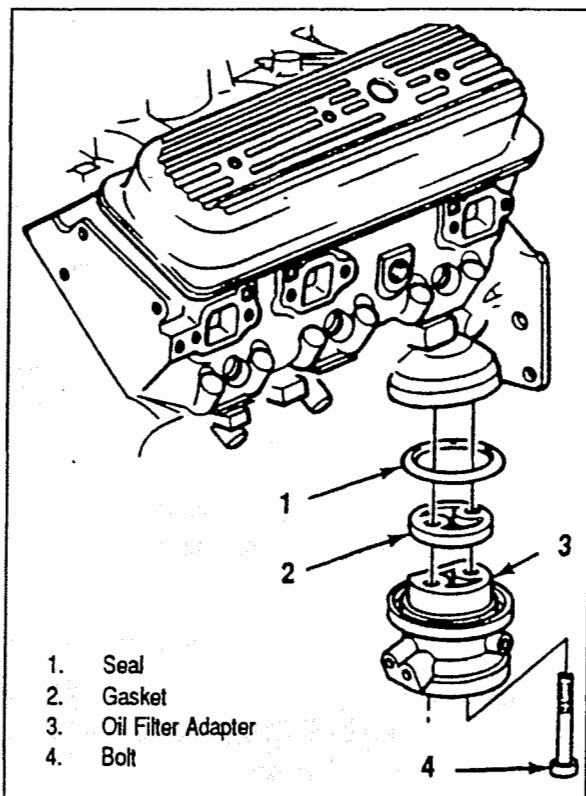

Oil Filter Adapter

Tighten:

- Bolts to 20 N•m (15 ft.lbs.)

3. Oil cooler lines.
4. Oil filter.
 - Add engine oil as needed.

CRANKSHAFT REPLACEMENT

- Remove the engine, as outlined later.

Remove or Disconnect:

1. Oil pan, as outlined previously.
2. Oil pump, as outlined previously (if necessary).
3. Connecting rod caps. **NOTE:** Check the connecting rod and cap for identification marks. Mark the parts if required. The connecting rod and cap must be kept together as mating parts.

4. Main bearing caps. **NOTE:** Check the main bearing caps for location markings. Mark the caps if necessary. The caps must be returned to their original locations during assembly.
5. Remove crankshaft.

Install or Connect:

1. Crankshaft.
2. Main bearing caps.
3. Connecting rod caps.
4. Oil pump.
5. Oil pan.

FLYWHEEL REPLACEMENT

Remove or Disconnect:

1. Transmission (if equipped), bellhousing and damper.
2. Flywheel bolts.
3. Flywheel.

Clean:

- Mating surfaces of crankshaft and flywheel. Remove any burrs.

Inspect:

- Flywheel for burning, scoring, warping and wear. Replace the flywheel if necessary. Do not machine the flywheel.
- Flywheel ring gear for worn or broken teeth.

FLYWHEEL RING GEAR REPLACEMENT

NOTICE: Never heat starter gear to red heat as this will change metal structure.

1. Use a torch to heat the gear around the entire circumference, then drive the gear off the flywheel, using care not to damage the flywheel.

FLYWHEEL RING GEAR REPLACEMENT (Continued)

2. Uniformly heat the flywheel gear to temperature which will expand the gear to permit installation. Temperature must not exceed 204°C (400°F).
3. As soon as the gear has been heated, install on the flywheel.

Install or Connect:

1. Flywheel.
2. Flywheel bolts.

Tighten:

- Flywheel bolts to 100 N•m (75 ft.lbs.)

3. Damper, bellhousing and transmission (if equipped).

ENGINE REPLACEMENT

Remove or Disconnect:

1. Battery cables (negative and positive).
2. Drain cooling system (See "Cooling Systems" section in this manual).
3. Power steering pump (if equipped) and lay aside.
4. Engine wiring harness from the engine.
5. Fuel line.
6. Exhaust hoses from the manifolds.
7. Water inlet hoses.
8. Flywheel cover.
9. Wiring, as necessary.
10. Coupling (if equipped).
11. Front engine trunion mounts from isolators and transmission mount from isolators or stringers.
12. Engine.

Install or Connect:

1. Engine in the boat.
 - Support with suitable safety stands.
 - Align coupling (Sportpac) or engine (Enpac).
2. Engine mounts.
3. Coupling bolts.

NOTICE: See "Notice" on page 11-1.

4. Wiring, as required.
5. Water inlet hoses.
6. Exhaust hoses to the manifolds.
7. Fuel line.
8. Engine wiring harness.
9. Power steering pump connections (if used).
10. Heater hoses.
11. Throttle and shift linkages. *NOTE: Insure throttle and shift linkage is properly adjusted for full travel.*
12. Battery cables.

ENGINE SPECIFICATIONS

All specifications are in INCHES unless otherwise noted.

GENERAL DATA:					
Type		V6			
Displacement		262 CID (4.3L)			
RPO		LB4			
Bore		4.00			
Stroke		3.48			
Compression Ratio		9.3:1			
Firing Order		1 - 6 - 5 - 4 - 3 - 2			
Oil Pressure (Minimum)		6 psi @ 1000 RPM; 18 psi @ 2000 RPM; 24 psi @ 4000 RPM			
CYLINDER BORE:					
Diameter		3.9995 - 4.0025			
Out of Round	Production		0.001 (Maximum)		
	Service		0.002 (Maximum)		
Taper	Production	Thrust Side	0.0005 (Maximum)		
		Relief Side	0.001 (Maximum)		
	Service		0.001 (Maximum)		
PISTON:					
Clearance	Production		0.0007 - 0.0017		
	Service Limit		0.0027 (Maximum)		
PISTON RING:					
C O M P R E S S I O N	Groove Clearance	Production	Top	0.0012 - 0.0032	
			2nd		
		Service Limit		Hi Limit Production + 0.001	
	Gap	Production	Top	0.010 - 0.020	
			2nd	0.010 - 0.025	
		Service Limit		Hi Limit Production + 0.010	

ENGINE SPECIFICATIONS

All specifications are in INCHES unless otherwise noted.

PISTON RING:				
O I L	Groove Clearance	Production	0.002 - 0.007	
		Service Limit	Hi Limit Production + 0.001	
	Gap	Production	0.015 - 0.055	
		Service Limit	Hi Production + 0.010	
PISTON PIN:				
Diameter		0.9270 - 0.09273		
Clearance In Piston	Production	0.0002 - 0.0007		
	Service Limit	0.001 (Maximum)		
Fit In Rod		0.0008 - 0.0016 Interference		
DISPLACEMENT:		4.3L		
CRANKSHAFT:				
Main Journal	Diameter	#1	2.4484 - 2.4493	
		#2, #3	2.4481 - 2.4490	
		#4	2.4479 - 2.4488	
	Taper	Production	0.0002 (Maximum)	
		Service Limit	0.001 (Maximum)	
	Out of Round	Production	0.0002 (Maximum)	
		Service Limit	0.001 (Maximum)	
	Main Bearing Clearance	Production	#1	0.0008 - 0.0020
#2, #3			0.0011 - 0.0023	
#4			0.0017 - 0.0032	
Service Limit		#1	0.0010 - 0.0015	
		#2, #3	0.0010 - 0.0025	
		#4	0.0025 - 0.0035	
Crankshaft End Play		0.002 - 0.006		

ENGINE SPECIFICATIONS (Continued)

All specifications are in INCHES unless otherwise noted.

CRANKSHAFT (Continued):			
Crankpin	Diameter		2.2487 - 2.2497
	Taper	Production	0.0005
		Service Limit	0.001 (Maximum)
	Out of Round	Production	0.0005
		Service Limit	0.001 (Maximum)
	Rod Bearing Clearance	Production	
Service Limit		0.0030	
Rod Side Clearance			0.006 - 0.014
CAMSHAFT:			
Lobe Lift \pm 0.002	Intake		0.357
	Exhaust		0.390
Journal Diameter			1.8682 - 1.8692
Camshaft End Play			0.004 - 0.012
VALVE SYSTEM:			
Lifter			Hydraulic
Rocker Arm Ratio			1.50:1
Valve Lash	Intake	One Turn Down From Zero Lash	
	Exhaust		
Face Angle (Intake & Exhaust)			45°
Seat Angle (Intake & Exhaust)			46°
Seat Runout (Intake & Exhaust)			0.002 (Maximum)
Seat Width	Intake	1/32 - 1/16	
	Exhaust	1/16 - 3/32	
Stem Clearance	Production	Intake	0.0010 - 0.0027
		Exhaust	0.0010 - 0.0027
	Service	Intake	Hi Limit Production + 0.001
		Exhaust	Hi Limit Production + 0.002

ENGINE SPECIFICATIONS (Continued)

All specifications are in INCHES unless otherwise noted.

VALVE SYSTEM (Continued):			
Valve Spring (Outer)	Free Length		2.03
	Pressure lbs. @ in.	Closed	76 - 84 lbs. @ 1.70-in.
		Open	1094 - 206 lbs. @ 1.25-in.
	Installed Height $\pm 1/32$ "		1 23/32
Valve Spring Damper	Free Length		1.86
	Approx. # of Coils		4

TORQUE SPECIFICATIONS

ITEM	N·m	FT. LBS.	IN. LBS.
Rocker Arm Cover Bolts	11.3		100
Intake Manifold Bolts	48	35	
Exhaust Manifold Bolts - Carter Two Bolts	36	26	
Exhaust Manifold Bolts - All Others	26	20	
Cylinder Head Bolts	90	65	
Torsional Damper Bolt	95	70	
Front Cover Bolts	11.3		100
Oil Pan Nuts	22.6		200
Oil Pan Bolts	11.3		100
Oil Pump Bolt	90	65	
Rear Crankshaft Oil Seal Retainer Screws and Nuts	15.3		135
Camshaft Sprocket Bolts	23	17	
Connecting Rod Cap Nuts	60	45	
Oil Filter Adapter Bolts	20	15	
Main Bearing Cap Bolts	100	75	
Oil Pump Cover Bolts	9.0		80
Flywheel Bolts	100	75	
Spark Plugs	30	22	
Water Outlet Bolts	28	21	
Water Pump Bolts	40	30	
Flywheel Housing Bolts	44	32	
Camshaft Thrust Plate Screws	11.9		105
Hydraulic Lifter Restrictor Retainer Bolts	16.4		145
Oil Pan Studs to Oil Seal Retainer or Crankcase	1.7		15

SPECIAL TOOLS



J-23523-E



J-5892-B



J-23590



J-35468



J-8080



J-8037

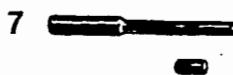

J-5239



J-23738-A



J-5802-01



J-5715



J-6036



J-6880



J-5825-A



J-5590



J-8520



J-35621

1. Torsional Damper Remover and Installer
2. Valve Spring Compressor
3. Air Adapter
4. Crankshaft Seal Installer and Centering Tool
5. Main Bearing Replacer
6. Piston Ring Compressor
7. Guide Set
8. Vacuum Pump

9. Stud Remover
10. Reamer (0.003-inch oversize)
11. Reamer (0.013-inch oversize)
12. Stud Installer
13. Crankshaft Gear Puller
14. Crankshaft Gear Installer
15. Dial Indicator Adapter
16. Rear Crankshaft Seal Installer

ENGINES: 305/350 CID (5.0L-5.7L)

SECTION 12

INTRODUCTION.....	2
DESCRIPTION.....	2
ENGINE LUBRICATION.....	2
ENGINE LUBRICATION DIAGRAMS.....	3
ROCKER ARM REPLACEMENT.....	5
ROCKER ARM AND PUSHROD REPLACEMENT.....	5
VALVE ADJUSTMENT.....	6
VALVE STEM SEAL AND VALVE SPRING REPLACEMENT.....	7
INTAKE MANIFOLD REPLACEMENT.....	8
HYDRAULIC LIFTER REPLACEMENT.....	9
ROCKER ARM STUD REPLACEMENT.....	10
EXHAUST MANIFOLD REPLACEMENT.....	11
EXHAUST MANIFOLD RISER REPLACEMENT.....	12
CYLINDER HEAD REPLACEMENT.....	12
TORSIONAL DAMPER AND FRONT CRANKSHAFT SEAL REPLACEMENT.....	13
FRONT COVER REPLACEMENT.....	14
OIL PAN REPLACEMENT.....	15
OIL PUMP REPLACEMENT.....	15
REAR CRANKSHAFT OIL SEAL REPLACEMENT.....	16
REAR CRANKSHAFT OIL SEAL RETAINER REPLACEMENT.....	17
MEASURING CAMSHAFT LOBE LIFT.....	18
CAMSHAFT REPLACEMENT.....	18
CONNECTING ROD AND PISTON REPLACEMENT.....	20
OIL FILTER ADAPTER AND OIL FILTER BYPASS VALVE REPLACEMENT.....	22
MAIN BEARING REPLACEMENT.....	22
CRANKSHAFT REPLACEMENT.....	24
CRANKSHAFT AND MAIN BEARING INSTALLATION.....	24
FLYWHEEL REPLACEMENT.....	26
FLYWHEEL RING GEAR REPLACEMENT.....	26
ENGINE REPLACEMENT.....	26
ENGINE SPECIFICATIONS CHART.....	28
FASTENER TORQUE SPECIFICATIONS CHART.....	31
SPECIAL TOOLS.....	32

INTRODUCTION

The following "Notice" applies to one or more steps in the assembly procedure of components in this portion of the manual as indicated at appropriate locations by the terminology "NOTICE".

NOTICE: When fasteners are removed, always reinstall them at the same location from which they were removed. If a fastener needs to be replaced, use the correct part number fastener for that application. If the correct part number fastener is not available, a fastener of equal size and strength (or stronger) may be used. Fasteners that are not reused, and those requiring thread locking compound will be called out. The correct torque value must be used when installing fasteners that require it. If the above conditions are not followed, parts or system damage could result.

DESCRIPTION

Small block engines covered by this manual are available in two displacements; 5.0L (305 cu.in.) and 5.7L (350 cu.in.).

Small block engines are 90-degree V8 type, overhead valve, water cooled, with cast iron block and heads. The 350 Premium and Performance models have aluminum cylinder heads.

The camshaft is supported by five plain type bearings and is chain driven. Motion from the camshaft is transmitted to the valves by hydraulic lifters, pushrods, and bail type rocker arms. The 350 Premium and Performance models have roller lifters and a roller profile camshaft. The valve guides are integral in the cylinder head.

The connecting rods are forged steel, with precision insert type crankpin bearings. The piston pins are a press fit in the connecting rods.

The pistons are cast aluminum alloy. The piston pins are a floating fit in the piston.

ENGINE LUBRICATION

Lubrication schematics are shown on pages 12-3 and 12-4. The gear type oil pump is driven from the distributor shaft, which is gear driven from the camshaft. Oil is drawn into the oil pump through a pickup screen and pipe.

Pressurized oil is routed to the oil filter(s). In case of excessive oil pressure, a bypass valve is provided. Filtered oil flows through the engine oil cooler (on Sportpac models) into the main gallery and then to the camshaft and crankshaft bearings. The valve lifter oil gallery supplies oil to the valve lifters. Oil flows from the hydraulic lifters through the hollow pushrods to the rocker arms. Oil from the overhead drains back to the crankcase through oil drain holes.

The timing chain is drip fed from the front camshaft bearing. The pistons and piston pins are lubricated by oil splash.

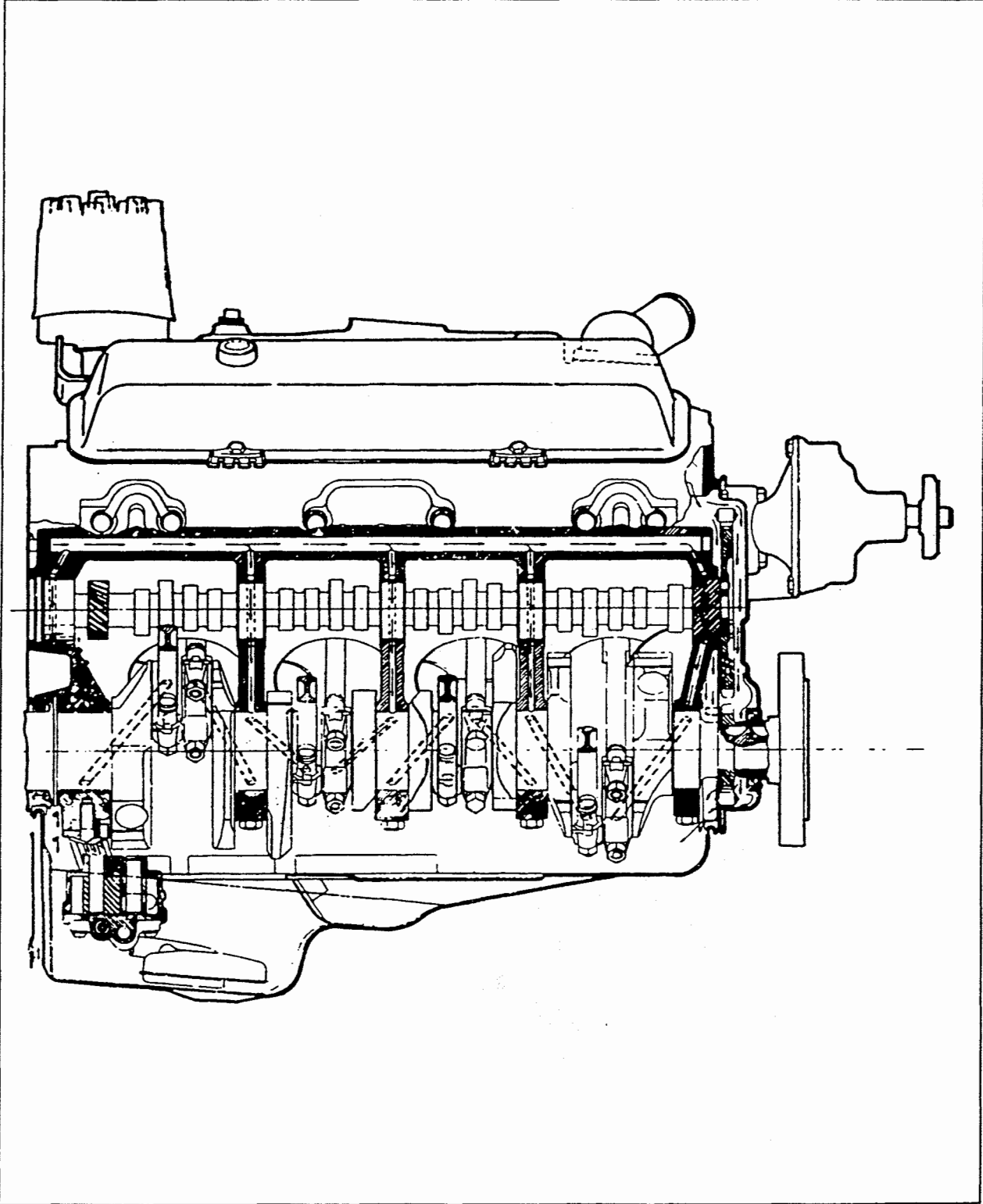

Engine Lubrication Diagram

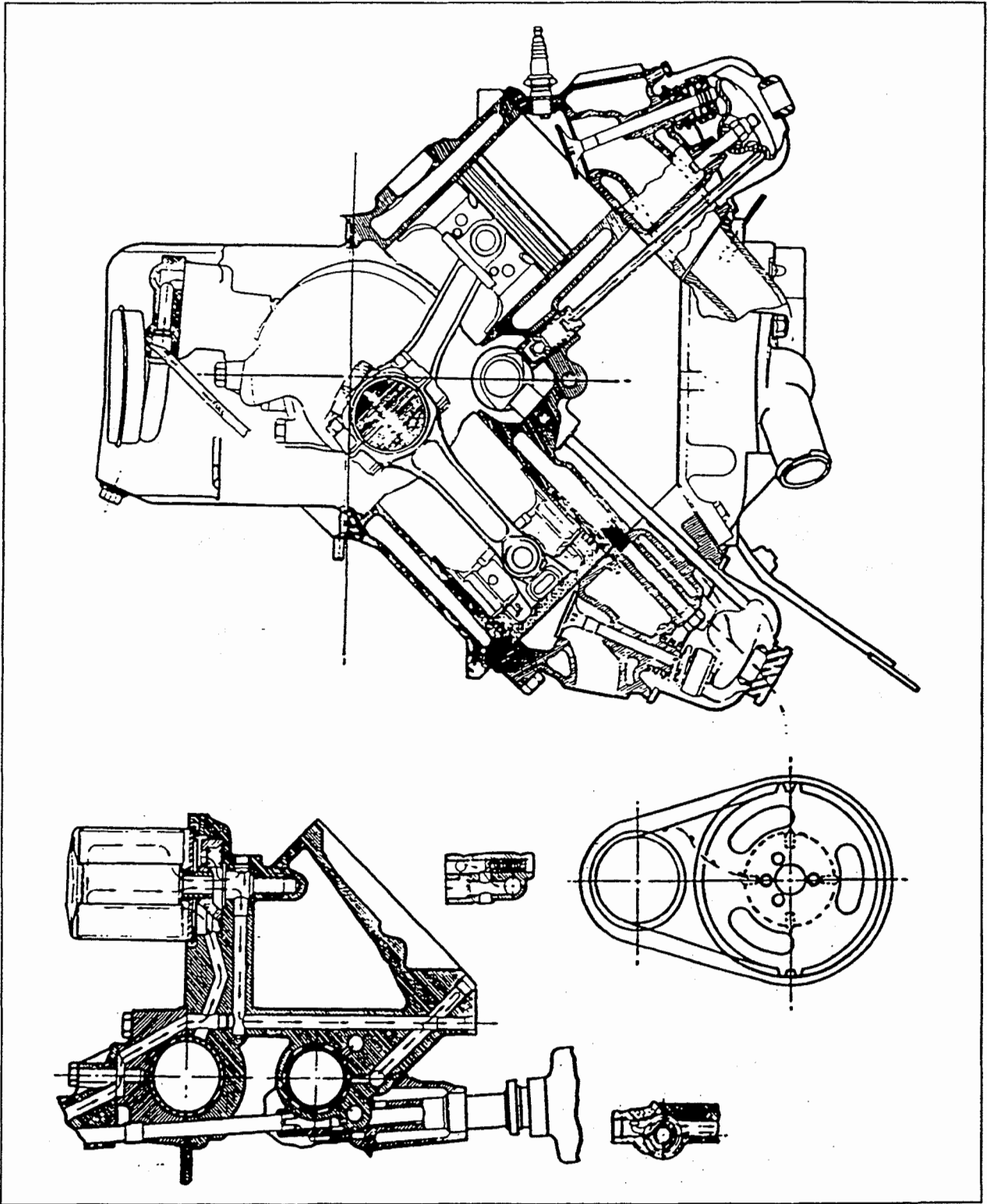

Engine Lubrication Diagram

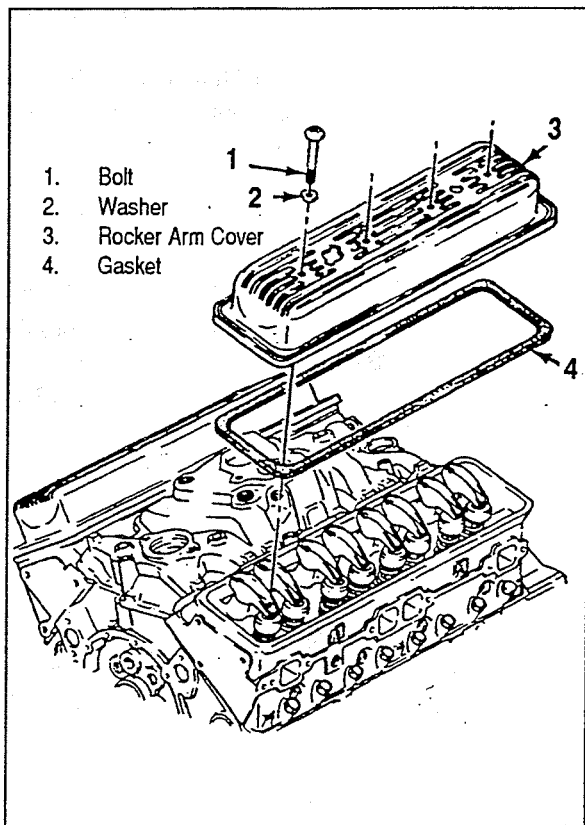
ROCKER ARM COVER REPLACEMENT**Rocker Arm Cover****Remove or Disconnect:**

1. Battery negative cable.
2. Crankcase ventilation hoses at the rocker arm covers.
3. Wiring harnesses from the clips, and move aside.
4. Components as follows (if necessary):
 - Exhaust riser
 - Map sensor bracket
 - Fresh water cooling hoses
(It may be necessary to partially drain system by removing plugs from rear of exhaust manifolds. See "Cooling Systems" section in this manual.)
5. Rocker arm cover bolts and washers.
6. Rocker arm cover and gasket.

Clean:

- All traces of old gasket from the rocker arm cover and cylinder head.

Inspect:

- Rocker arm cover sealing surface for distortion. Replace if necessary.

Install or Connect:

1. Rocker arm cover and new gasket.
2. Rocker arm cover bolts and washers.

Tighten:

- Bolts to 11.3 N•m (100 in.lbs).
3. Components (as removed in preceding steps).
 4. Crankcase ventilation hoses.
 5. Battery negative cable.

ROCKER ARM AND PUSHROD REPLACEMENT**Remove and Disconnect:**

1. Rocker arm cover, as outlined previously
2. Rocker arm nut.
 - If only the pushrod is to be replaced, back the rocker arm nut off until the rocker arm can be swung away from the pushrod. Then pull the pushrod out.
3. Rocker arm with ball.
4. Pushrod.

IMPORTANT! Store used components in order so they can be reassembled in the same location.

Inspect:

- Rocker arms and balls at their mating surfaces. These surfaces should be smooth and free from scoring or other damage.

ROCKER ARM AND PUSHROD REPLACEMENT (Continued)

- Rocker arm areas which contact the valve stems and the sockets which contact the pushrods. These areas should be smooth and free of damage and wear.
- Pushrods for bending. Roll the pushrod on a flat surface to determine if it is bent. Replace if necessary.
- Ends of the pushrods for scoring or roughness.

Install or Connect:

1. Pushrod. Make sure the pushrod seats properly in the hydraulic lifter.
2. Rocker arm with ball.

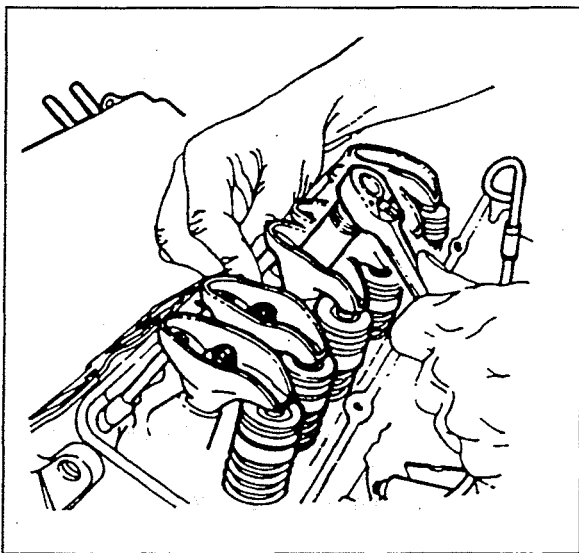

Adjusting the Valves

IMPORTANT! When new rocker arms and/or balls are installed, coat their bearing surfaces with "Molykote" or equivalent.

3. Rocker arm nut.

Adjust:

- Valves as outlined later.
4. Rocker arm cover, as outlined previously.

VALVE ADJUSTMENT

1. Remove the rocker arm cover as outlined previously.
2. Crank the engine until the mark on the vibration damper lines up with the "O" mark on the timing tab and the engine in the number one firing position. This may be determined by placing fingers on the number one valve as the mark on the damper comes near the "O" mark on the timing tab. If the rocker arms are not moving, the engine is in the number one firing position. If the rocker arms move as the mark comes up to the timing tab, the engine is in the number six firing position and should be turned over one more time to reach the number one position.
3. With the engine in the number one firing position as determined above, the following valves may be adjusted:

- Exhaust: 1,3,4,8
- Intake: 1,2,5,7

(Even numbered cylinders are in the right bank; odd numbered cylinders are in the left bank, when viewed from the rear of the engine).

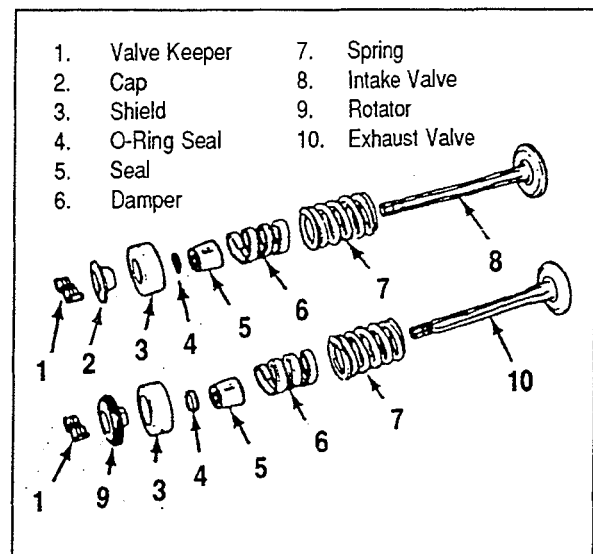

Valves and Components

4. Back out the adjusting nut until lash is felt at the pushrod then turn in the adjusting nut until all lash is removed. This can be determined by rotating the pushrod while turning the adjusting

VALVE ADJUSTMENT (Continued)

nut. When the play has been removed, turn the adjusting nut in one full additional turn (to center the lifter plunger).

5. Crank the engine one revolution until the timing tab "O" mark and vibration damper mark are again in alignment. This is the number six firing position the following valves may be adjusted:
 - Exhaust: 2,5,6,7
 - Intake: 3,4,6,8
6. Install the rocker arm cover as outlined previously.

- Install a rocker arm nut (figure 6).
 - Use J-8062 to compress the valve spring.
 - Remove the valve keepers.
 - Carefully release the spring tension. Remove J-8062.
5. Cap and/or rotor, shield and spring with damper.
 6. O-ring seal.
 7. Seal (intake valve only).

**VALVE STEM SEAL AND
VALVE SPRING REPLACEMENT**

Remove or Disconnect:

Tools required:

- J-23590 Air Adapter
- J-8062 Spring Compressor

1. Rocker arm cover, as outlined previously.
2. Rocker arms, as outlined previously.
3. Spark plugs.
4. Valve keepers.
 - Install J-23590 into the spark plug hole.

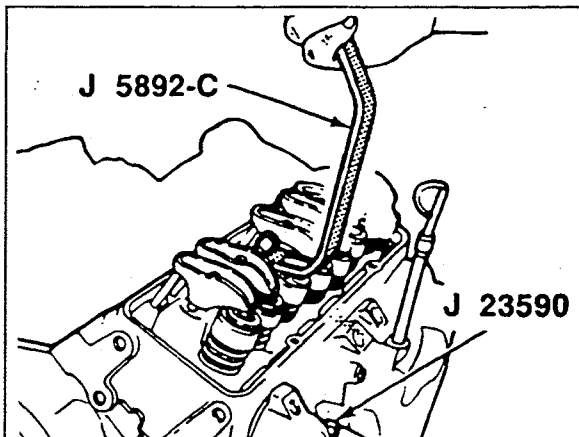
**Compressing the Valve Springs**

- Apply compressed air to hold the valves in place.

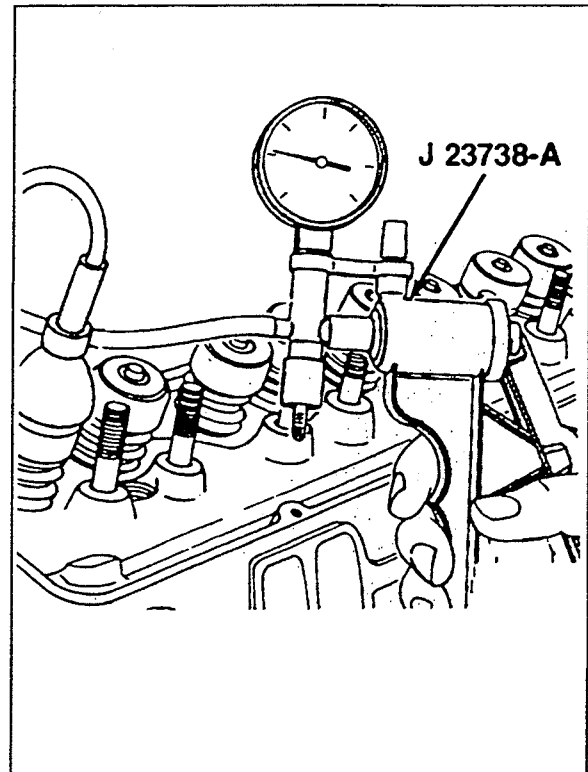
**Testing the Valve Seals****Install or Connect:**

Tools required:

- J-23590 Air Adapter
- J-8062 Spring Compressor
- J-23738-A Vacuum Pump

1. New seal (intake valve only). Install the seal over the valve stem and seat it against the head.
2. Spring with damper, shield and cap and/or rotator.
3. New O-ring seal and valve keepers.
 - With air pressure applied to the cylinder with J-23590, compress the spring with J-8062.

VALVE STEM SEAL AND VALVE SPRING REPLACEMENT (Continued)

- Lubricate the O-ring seal with engine oil.
 - Install the seal on the valve stem. Make sure the seal is not twisted.
 - Install the valve keepers. Use grease to hold them in place.
 - Carefully release spring pressure. Make sure the valve keepers stay in place.
 - Remove J-23590 and J-8062.
 - Check each O-ring seal for leakage.
 - Place the suction cup furnished with J-23738-A over the shield.
 - Connect J-23738-A to the suction cup and apply a vacuum. Watch the vacuum pump gauge. No air should be able to leak past the seal. If the seal will not hold a vacuum, it may have been damaged or improperly installed.
4. Spark plugs.
 5. Rocker arms, as outlined previously.
- Adjust:**
- Valves as outlined previously.
6. Rocker arm cover, as outlined previously.

INTAKE MANIFOLD REPLACEMENT

Remove or Disconnect:

1. Battery negative cable.
2. Flame arrestor.
 - Drain the cooling system. (See "Cooling Systems" section in this manual.)
3. Cooling hoses.
4. Fuel line(s).
5. Components as follows (if equipped):
 - Carburetor or TBI unit
 - Vacuum hoses at the manifold
 - Map sensor bracket
 - Electrical connections at the manifold and TBI unit
 - Electrical component bracket

6. Distributor. (See "Engine Electrical" section in this manual.)
7. Coil wires.
8. Intake manifold bolts.
9. Intake manifold.
10. Gaskets.

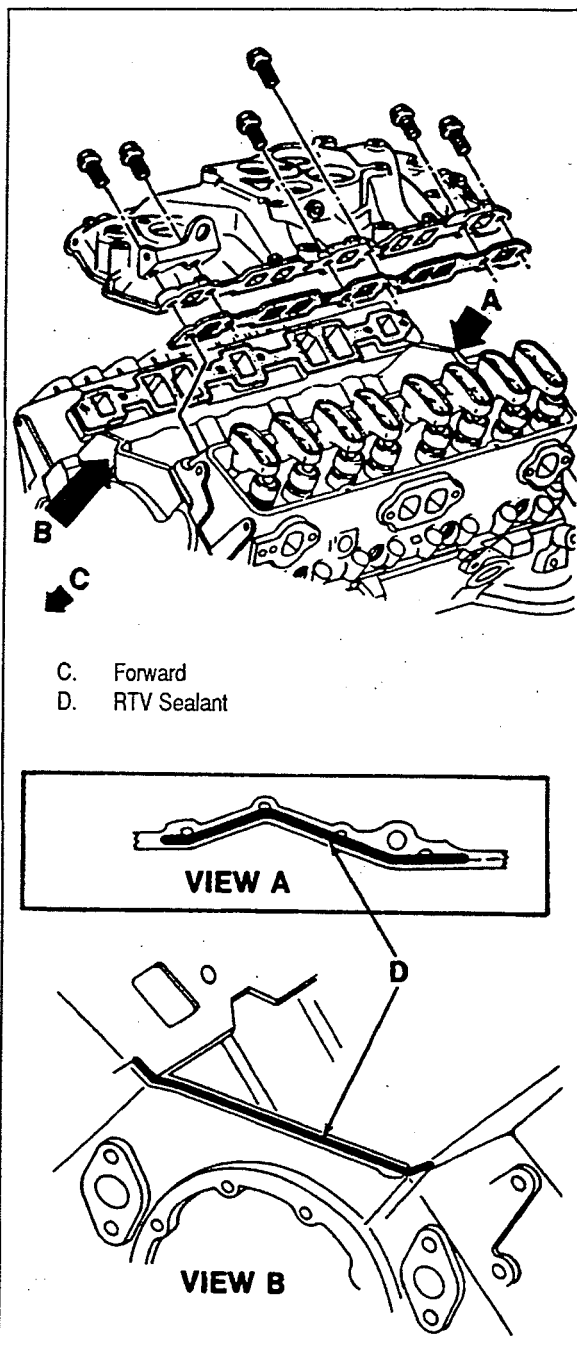

INTAKE MANIFOLD REPLACEMENT (Continued)**Clean:**

- Old gasket and RTV from the block, heads, and intake manifold. Remove all RTV that is loose or will cause interference at assembly.
- Excessive carbon deposits from the exhaust and EGR passages.
- Excessive scale and deposits from the coolant passages.

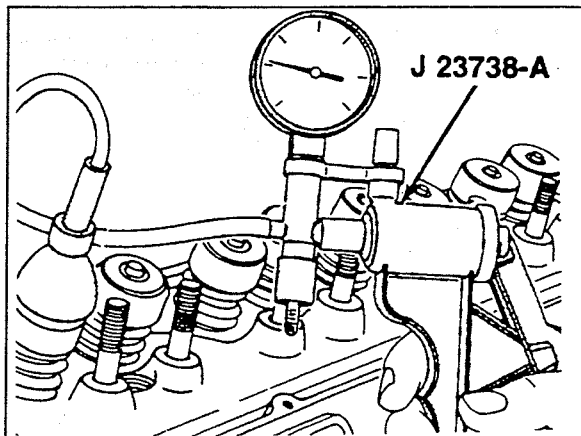
**Inspect:**

- Manifold for cracks and gasket surface damage.

Install or Connect:

1. Gaskets to the cylinder head.
2. RTV to the front and rear sealing surfaces on the block. Apply a 5 mm (3/16") bead of RTV to the front and rear of the block as shown. Extend the bead 13 mm (1/2") up each cylinder head to seal and retain the gaskets.
3. Intake manifold to the engine.
4. Intake manifold bolts.

Tighten:

- Intake manifold bolts to 48 N-m (35 ft.lbs). Use the tightening sequence shown.
5. Carburetor or TBI unit (if removed).
 6. Fuel line(s).
 7. MAP sensor and bracket.
 8. Coil wires.
 9. Distributor. (See "Engine Electrical" section in this manual.)

10. Electrical connections.
11. Vacuum hoses.
12. Cooling hoses.
13. Flame arrestor and weather cover.
14. Battery negative cable.
 - Fill the cooling system with the proper quantity and grade of coolant.

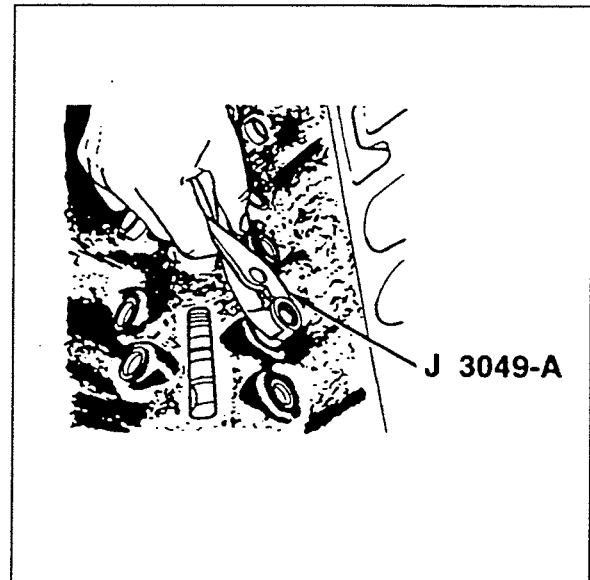
*Removing the Hydraulic Lifter***HYDRAULIC LIFTER REPLACEMENT****Remove and Disconnect:****Tools required:**

- J-3049 Hydraulic Lifter Remover (Plier type) or
- J-9290-01 Hydraulic Lifter Remover (Slide Hammer type)

1. Rocker arm cover, intake manifold, and pushrod, as outlined previously.
2. Hydraulic lifters.
 - Remove the hydraulic lifters one at a time and place them in an organizer rack. The lifters must be installed in the same bore from which they were removed.
 - A stuck hydraulic lifter can be removed using J-3049 or J-9290-01

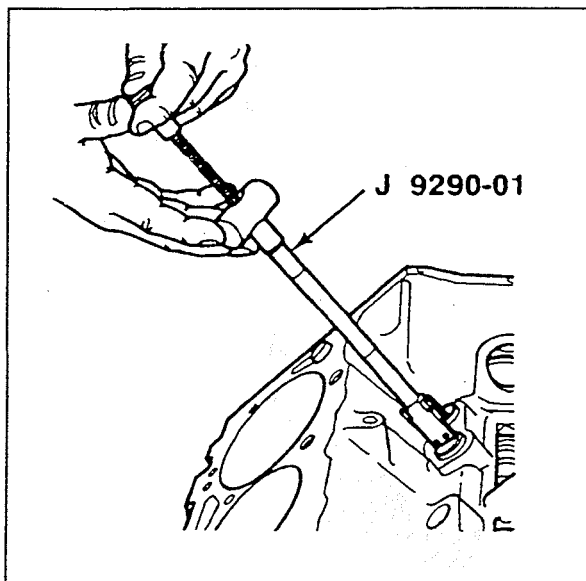
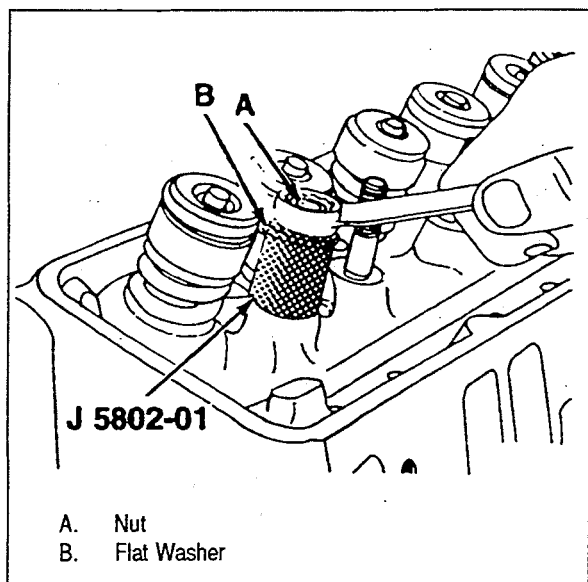
HYDRAULIC LIFTER REPLACEMENT (Continued)**Removing the Hydraulic Lifter (Typical)****Removing the Rocker Arm Stud****Inspect:**

- Hydraulic lifter body for scuffing and scoring. If the lifter body wall is worn or damaged, the mating bore in the block should also be checked.
- Check the fit of each hydraulic lifter in its mating bore in the block. If the clearance is excessive, try a new lifter.

- The hydraulic lifter foot must be smooth and slightly convex. If worn, pitted, or damaged, the mating camshaft lobe should also be checked.

Install or Connect:

1. Hydraulic lifters on the block. Lubricate the lifter foot and body with an engine oil supplement or equivalent.

IMPORTANT! When any new hydraulic lifter or a new camshaft is installed, change the engine oil and filter. Engine oil supplement or equivalent should be added to the crankcase oil. Replace all hydraulic lifters when a new camshaft is installed.

2. Intake Manifold, as outlined previously.
3. Pushrod, as outlined previously.

Adjust:

- Valves, as outlined previously.
4. Rocker arm cover, as outlined previously.

ROCKER ARM STUD REPLACEMENT**Remove or Disconnect:**

Tools required:

J-5802-01 Rocker Arm Stud Remover

1. Rocker arm cover and rocker arm, as outlined previously.
2. Rocker arm stud.
 - Place J-5802-01 over the rocker arm stud.
 - Install a nut and flat washer.
 - Turn the nut to remove the stud.

Install or Connect:

Tools required:

J-5715 Reamer (0.003 inch oversize) or

J-6036 Reamer (0.013 inch oversize)

J-6880 Rocker Arm Stud Installer

ROCKER ARM STUD REPLACEMENT (Continued)

- Ream the hole to the proper size for the replacement oversize rocker arm stud. Use J-5715 for 0.003-inch oversize studs; J-6036 for 0.013-inch oversize studs.

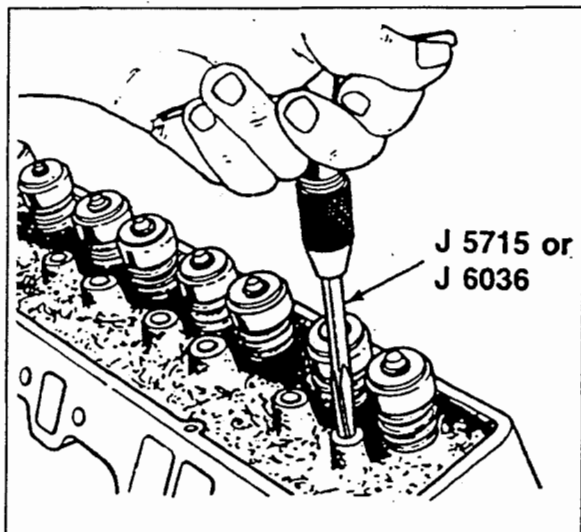
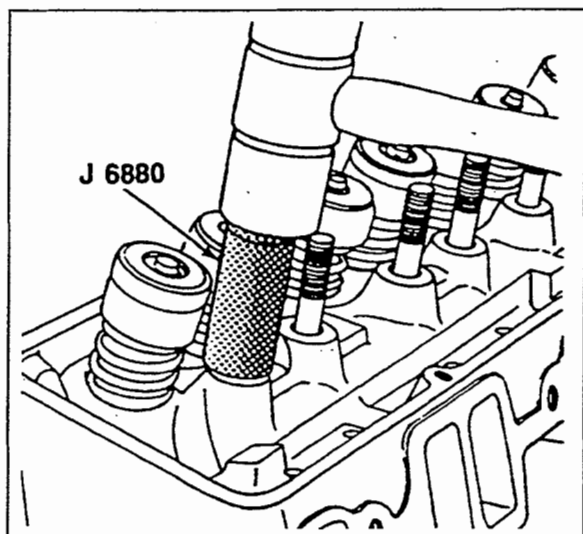
**Reaming the Rocker Arm Stud Bore (Typical)****Installing the Rocker Arm Stud**

- Coat lower end (press-fit area) of rocker arm stud with hypoid axle lubricant.

NOTICE: Do not attempt to install an oversize rocker arm stud without reaming stud hole as this could damage the cylinder head.

1. Rocker arm stud. Use J-6880. Stud is installed to proper depth when the tool bottoms on the cylinder head.
2. Rocker arm, as outlined previously.

Adjust:

- Valves, as outlined previously.

3. Rocker arm cover, as outlined previously.

EXHAUST MANIFOLD REPLACEMENT**Remove or Disconnect:**

1. Battery negative cable.
2. Drain coolant. (See "Cooling Systems" section in this manual.)
3. Exhaust hose(s) at the manifold/riser.
4. Dipstick tube bracket (if necessary).
5. Exhaust manifold bolts and lockwashers, if equipped.
6. Exhaust manifold.

IMPORTANT! New engines are assembled with Permatex® sealant instead of gaskets. Unless mating surfaces are like new, gasket should be used when replacing manifold.

Clean:

- Mating surfaces on the manifold and head.
- Threads on the exhaust manifold bolts.

Install or Connect:

1. Exhaust manifold to the cylinder head.
2. Exhaust manifold fasteners.

Tighten:

- Two center bolts to 36 N-m (26 ft.lbs.)
- Outside bolts to 28 N-m (20 ft.lbs.)

EXHAUST MANIFOLD REPLACEMENT (Continued)

3. Dipstick tube bracket (if necessary).
4. Exhaust hose.
5. Coolant (See "Cooling Systems" section in this manual).
6. Battery negative cable.

EXHAUST MANIFOLD RISER REPLACEMENT

Remove or Disconnect:

1. Battery negative cable.
2. Coolant from exhaust manifold. (See "Cooling Systems" section in this manual.)
3. Exhaust hose.
4. Riser bolts and lockwashers.
5. Riser.

Clean:

- Mating surfaces on the manifold and riser.
NOTE: In some cases, sealant was used during original assembly. Gaskets currently available do not require sealant but surfaces must be well cleaned.
- Threads on the riser bolts.

Install or Connect:

1. Riser to exhaust manifold with new gasket.
2. Riser bolts and lockwashers. *NOTE: Apply Loctite® Threadlocker 242 sealant or equivalent to bolt threads before installations.*

Tighten:

- Diagonally opposite riser bolts to 34 N•m (25 ft.lbs.)
 - Remaining two riser bolts to 34 N•m (25 ft.lbs.)
3. Exhaust hose.
 4. Coolant. (See "Cooling Systems" section in this manual.)
 5. Battery negative cable.

CYLINDER HEAD REPLACEMENT

Remove or Disconnect:

1. Battery negative cable.
 - Drain the cooling system.
2. Intake manifold, as outlined previously.
3. Exhaust manifold, as outlined previously.
4. Components as follows (if necessary):
 - Alternator bracket (port side only)
 - Fresh water cooling tank bracket(s)
 - Fuel water separator
 - Electric fuel pump
 - Spark plug wire brackets at the rear of the cylinder head
5. Rocker arm cover, as outlined previously.
6. Spark plugs.
7. Pushrods, as outlined previously.
8. Cylinder head bolts.
9. Cylinder head.
10. Head gasket.

Clean :

- Carbon deposits from combustion chambers.
- All traces of old head gasket from cylinder head and block.
- Cylinder head bolt threads and threads in the block.

Inspect:

- Sealing surfaces of the block and cylinder head for nicks, heavy scratches, or other damage.

Install or Connect:

1. Head gasket.
 - Use only marine gasket.
 - Place the gasket over the block dowel pins with the bead up.
2. Cylinder head. Carefully guide the cylinder head into place over the dowel pins and gasket.
3. Cylinder head bolts. Coat threads of the cylinder head bolts with sealing compound (Permatex® recommended) and install finger-tight.

CYLINDER HEAD REPLACEMENT (Continued)

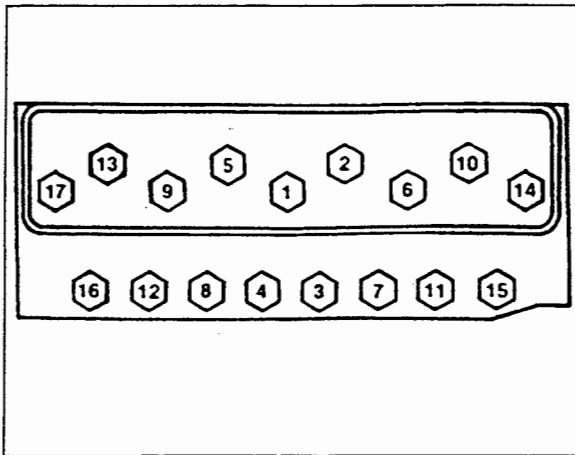

Cylinder Head Bolt Tightening Sequence

Tighten :

- Cylinder head bolts, a little at a time, using the sequence shown in figure 15. Proper torque is 90 N-m (65 ft.lbs.)

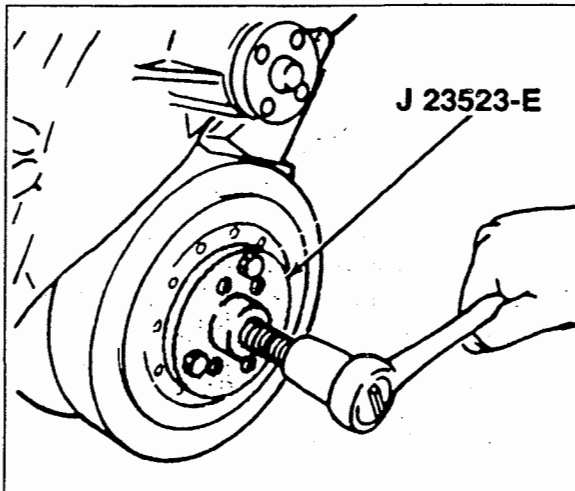

Removing the Torsional Damper

4. Pushrods, as outlined previously.

Adjust:

- Valves, as outlined previously.
5. Rocker arm cover, as outlined previously.
 6. Spark plugs.
 7. Components as follows (if equipped):
 - Alternator bracket

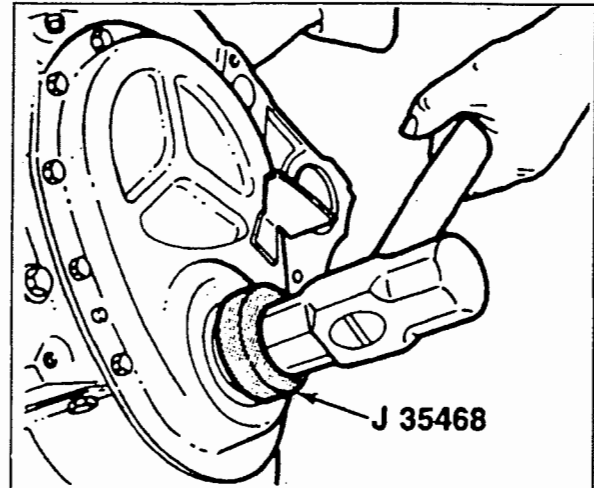

Installing the Front Crankshaft Oil Seal

- Fresh water cooling tank bracket(s)
 - Fuel water separator
 - Electric fuel pump
 - Spark plug wire brackets at the rear of the cylinder head.
8. Exhaust manifold, as outlined previously.
 9. Intake manifold, as outlined previously.
 10. Battery negative cable.
 - Fill the cooling system with the proper quantity and grade of coolant.

TORSIONAL DAMPER AND FRONT CRANKSHAFT SEAL REPLACEMENT

Remove or Disconnect:

Tool required:

J-23523-E Torsional Damper Puller and Installer

1. Seawater pump and bracket (if equipped).
2. Alternator belt(s) and crankshaft pulley.
3. Torsional damper bolt.
4. Torsional damper. Use J-23523-E.
5. Front crankshaft seal. Pry out with a large screwdriver. Take care not to distort the timing cover.

TORSIONAL DAMPER AND FRONT CRANKSHAFT SEAL REPLACEMENT (Continued)

6. Crankshaft key, if necessary.

Inspect:

- Oil seal contact area on the torsional damper shaft for grooving and roughness. Replace if necessary.

Install or Connect:

Tools required:

- J-35468 Seal Installer
- J-23523-E Torsional Damper Puller & Installer

1. Crankshaft key, if removed.
2. Front crankshaft seal. Use J-35468. The open end of the seal faces inside the engine. Coat the seal lips with engine oil.

NOTICE: The inertia weight section of the torsional damper is assembled to the hub with a rubber type material. The correct installation procedures (with the proper tool) must be followed or movement of the inertia weight section of the hub will destroy the tuning of the torsional damper.

3. Stud (item A in previous figure) to the crankshaft. Thread the stud fully into the tapped hole in the crankshaft.
4. Torsional damper over the end of the stud. Align the keyway in the torsional damper shaft with the crankshaft key.
5. Bearing, washer and nut.
 - Turn the nut to pull the vibration damper into place.
 - Remove the tool.
 - Use a small amount of RTV sealant to seal the torsional damper key to crankshaft joint.
6. Torsional damper bolt and washer.

Tighten:

- Bolt to 95 N-m (70 ft.lbs.)
7. Crankshaft pulley and alternator belt(s).

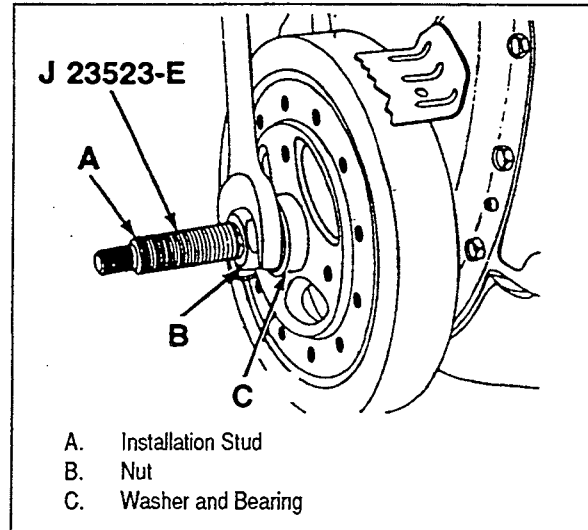

Installing the Torsional Damper

FRONT COVER REPLACEMENT

Remove or Disconnect:

1. Torsional damper, as outlined previously.
2. Water pump.
3. Oil pan, as outlined later.
4. Front cover bolts.
5. Front cover.
6. Front cover to block gasket.
7. Front crankshaft seal from the front cover. Pry out with screwdriver. Take care not to distort the front cover.

Clean:

- Old gasket from the front cover and block.

Inspect:

- Front cover for distortion and damage. Replace if necessary.

Install or Connect:

Tools required:

- J-35468 Seal Installer

1. Front crankshaft seal. Use J-354568. The open end of the seal faces inside the engine. Coat the seal lips with engine oil.

FRONT COVER REPLACEMENT (Continued)

2. Front cover gasket to the front cover. Use gasket cement to hold it in place.
3. Front cover to the engine.

Tighten:

- Front cover to block bolts to 11.3 N•m (100 in.lbs.)
4. Oil pan, as outlined later.
 5. Water pump. (See "Cooling System" section in this manual.)
 6. Torsional damper, as outlined previously.

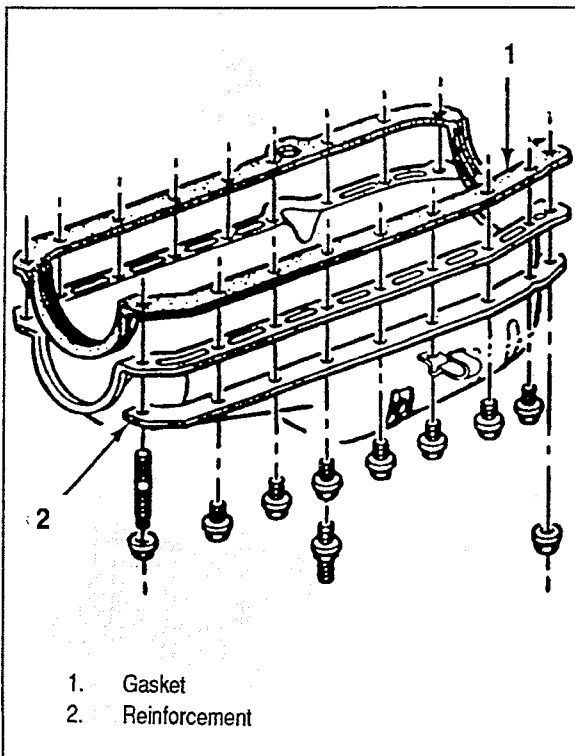
**Oil Pan****OIL PAN REPLACEMENT**

A one piece type oil pan gasket is used.

Remove or Disconnect:

1. Battery negative cable.

2. Raise the engine, if necessary. (In some cases, it may be necessary to remove engine from boat.)
 - Support with suitable safety stands
 - Drain the engine oil
3. Oil pan bolts, nuts and reinforcements. *NOTE: Some engines are equipped with cast aluminum oil pans. These pans do not require reinforcements.*
4. Oil pan and gasket.

Clean:

- Gasket surfaces on the engine and oil pan.

Inspect:

- Oil pan gasket for damage. Replace if necessary.

Install or Connect:

- *NOTE: If cast aluminum pan is to be installed in place of stamped steel pan, stock oil baffle must be replaced with modified baffle with Marine Power part #0007-305 before proceeding.*

1. Oil pan gasket to the oil pan.
2. Oil pan to the engine.
3. Oil pan bolts, nuts and reinforcements.

Tighten:

- Oil pan bolts to 11.3 N•m (100 in.lbs.)
- Oil pan nuts to 22.6 N•m (200 in.lbs.)

4. Lower engine, if necessary.
5. Proper quantity and grade of engine oil.
6. Battery negative cable.

OIL PUMP REPLACEMENT**Remove or Disconnect:**

1. Oil pan, as outlined previously.
2. Oil pump bolt.
3. Oil pump.

OIL PUMP REPLACEMENT (Continued)**Inspect:**

- Oil pump pickup tube for looseness. If the tube is loose in the oil pump body, replace it, as outlined in the proper unit repair manual. A loose pickup tube can result in an air leak and loss of oil pressure.

Install or Connect:

- Oil pump to the engine. Align the slot in the oil pump shaft with the tang on the distributor shaft. The oil pump should slide easily into place. No gasket is used.
- Oil pump bolt.

Tighten:

- Bolt to 90 N•m (65 ft.lbs.)

- Oil pan, as outlined previously.

**REAR CRANKSHAFT OIL SEAL
REPLACEMENT**

Remove or Disconnect:

- Transmission, if equipped.
- Damper and flywheel or flexplate, as equipped.

NOTICE: Care should be taken when removing the rear crankshaft oil seal so as not to nick the crankshaft sealing surface.

- Rear crankshaft oil seal. Insert a screwdriver into the notches provided in the seal retainer and pry the seal out (see figure below). Take care not to damage the crankshaft seal surface.

Inspect:

- Chamfer on crankshaft for grit, loose rust, and burrs. Correct if necessary.

Clean:

- Seal running surface on the crankshaft with a non-abrasive cleaner.

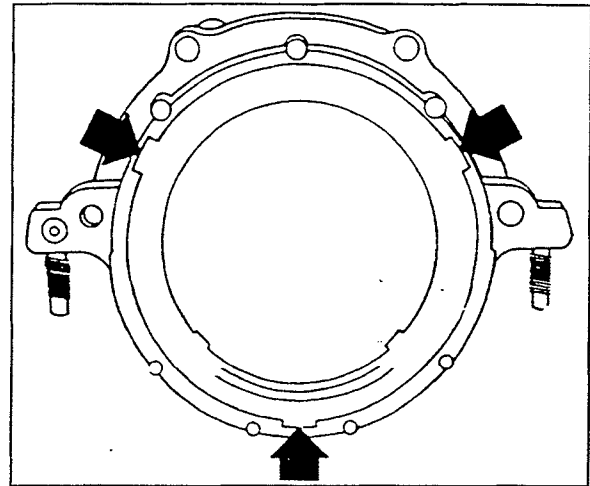
**Seal Removal Notches****Install or Connect:**

Tool required:

J-35621 Seal Installer

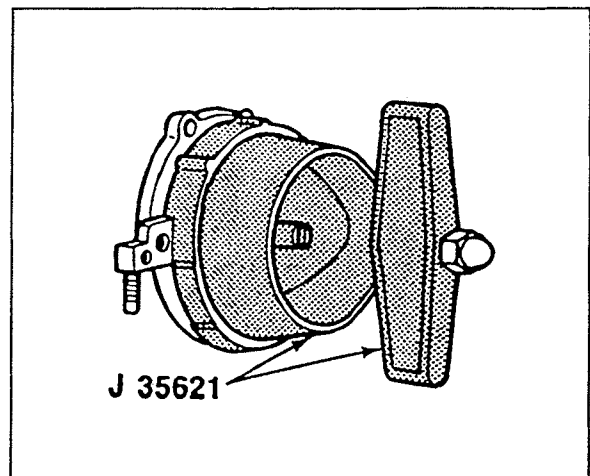
**Installing the Rear Crankshaft Oil Seal**

- Rear crankshaft oil seal (see figure below).
 - Lubricate the inner and outer diameter of the seal with engine oil.
 - Install the seal on J-35621.
 - Position J-35621 against the crankshaft. Thread the attaching screws into the tapped holes in the crankshaft.

REAR CRANKSHAFT OIL SEAL REPLACEMENT (Continued)

- Tighten the screws securely with a screwdriver. This will insure that the seal is installed squarely over the crankshaft.
 - Turn the handle until it bottoms.
 - Remove J-35621.
2. Damper and flywheel or flexplate, as equipped.
 3. Transmission, if equipped.

REAR CRANKSHAFT OIL SEAL RETAINER REPLACEMENT

Remove or Disconnect:

1. Transmission, if equipped.
2. Damper and flywheel or flexplate, as equipped.
3. Oil pan, as outlined previously.
4. Screws and nuts.
5. Seal retainer.

6. Gasket.
7. Rear crankshaft oil seal. Insert a screwdriver into the notches provided in the seal retainer and pry the seal out.

Clean:

- Gasket surfaces on block and seal retainer.

Install or Connect:

- Whenever the seal retainer is removed, a new retainer gasket and rear crankshaft oil seal must be installed.
1. Gasket to the block. It is not necessary to use sealant to hold the gasket in place.
 2. Seal retainer.
 3. Screws and nuts.

Tighten:

- Screws and nuts to 15.3 N•m (135 in.lbs.)
4. Oil pan, as outlined previously.
 5. Rear crankshaft oil seal as outlined previously.

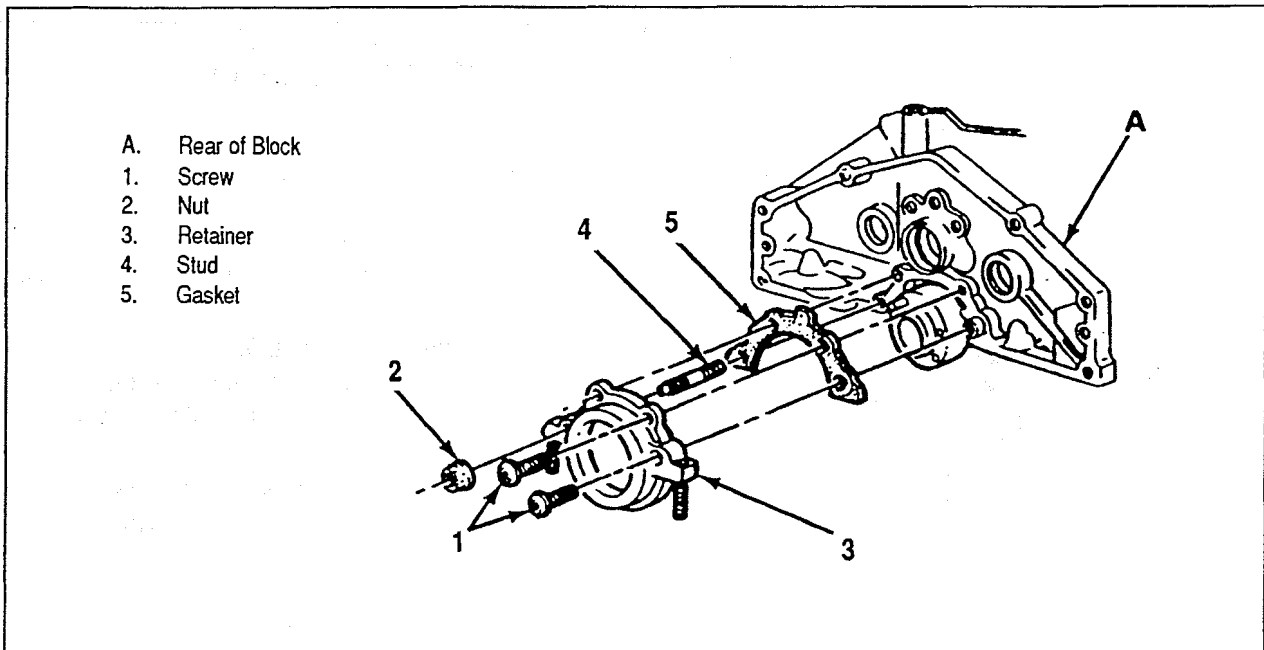

Rear Crankshaft Oil Seal Retainer

REAR CRANKSHAFT OIL SEAL RETAINER REPLACEMENT (Continued)

6. Damper and flywheel or flexplate, as equipped.
7. Transmission, if equipped.

MEASURING CAMSHAFT LOBE LIFT

Tool required:

J-8520 Camshaft Lobe Lift Indicator

1. Remove the rocker arm, as outlined previously.
2. Position the dial indicator so the plunger rests on the pushrod end, as shown in figure below. Make sure the pushrod is in the lifter socket.
3. Rotate the crankshaft slowly in the direction of normal rotation until the lifter is on the heel of the cam lobe. At this point, the pushrod will be in its lowest position.
4. Set dial indicator on zero, then rotate the crankshaft slowly, or attach an auxiliary starter switch and "bump" the engine over, until the pushrod is in fully raised position.

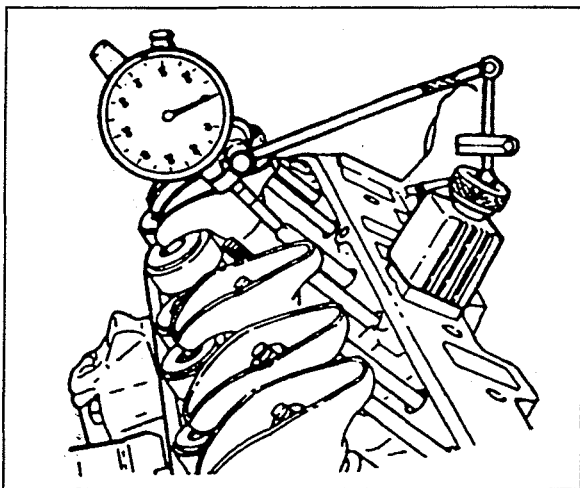

Measuring Camshaft Lobe Lift

5. Compare the total lift recorded from the dial indicator with specifications.
6. If camshaft readings for all lobes are within specifications, remove dial indicator assembly.

IMPORTANT! Whenever the engine is cranked remotely at the starter, with a special jumper cable or other means, the distributor primary lead or coil primary leads should be disconnected.

7. Install the rocker arm and adjust the valves as previously outlined.

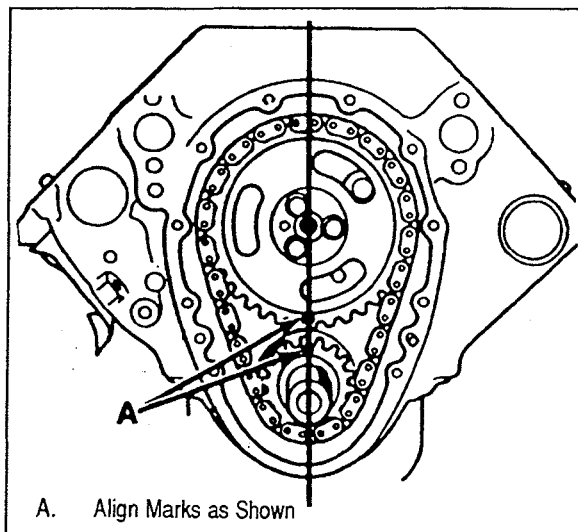

A. Align Marks as Shown

Timing Marks

CAMSHAFT REPLACEMENT

Remove or Disconnect:

Tool required:

J-5825-A Crankshaft Sprocket Puller

1. Battery negative cable.
2. Weather cover and flame arrestor.
3. Rocker arm covers, as outlined previously.
4. Water pump.
5. Torsional damper, as outlined previously.
6. Front cover, as outlined previously.
7. Distributor. (See "Engine Electrical" section in this manual.)
8. Intake manifold, as outlined previously.
9. Pushrods and hydraulic lifters, as outlined previously.
 - Align the timing marks.
10. Camshaft sprocket bolts.

CAMSHAFT REPLACEMENT (Continued)

11. Camshaft sprocket and timing chain. The sprocket is a light interference fit on the camshaft. Tap the sprocket on its lower edge to loosen it.
12. Crankshaft sprocket (if required). Use J-5825-A.
13. Engine mounting nuts. (If engine is to be raised or removed.)
 - Raise the engine if forward clearance is insufficient.
14. Camshaft.
 - Install two or three 5/16-18 bolts 100-125 mm (4-5 inches) long into the camshaft threaded holes. Use these bolts to handle the camshaft.
 - Pull the camshaft from the block. Use care to prevent damage to the camshaft bearings.

Cleaning, Inspection and Repair:

- Clean, inspect and repair or replace the camshaft and related components

Install or Connect:

Tool required:
J-5590 Crankshaft Sprocket Installer

- Coat the camshaft lobes and journals with a high quality engine oil supplement.
1. Two or three 5/16-18 bolts 100-125 mm (4-5 inches) long into the camshaft threaded holes. Use these bolts to handle the camshaft.
 2. Camshaft to the engine. Handle the camshaft carefully to prevent damage to the camshaft bearings.
 3. Lower engine (if previously raised or engine mounting removed).
 4. Align engine.

Tighten:

- Through-bolts to specifications.

5. Crankshaft sprocket (if removed). Use J-5590. Make sure the timing mark faces outside.
6. Camshaft sprocket and timing chain
7. Camshaft sprocket bolts.

8. Hydraulic lifters and pushrods, as outlined previously.

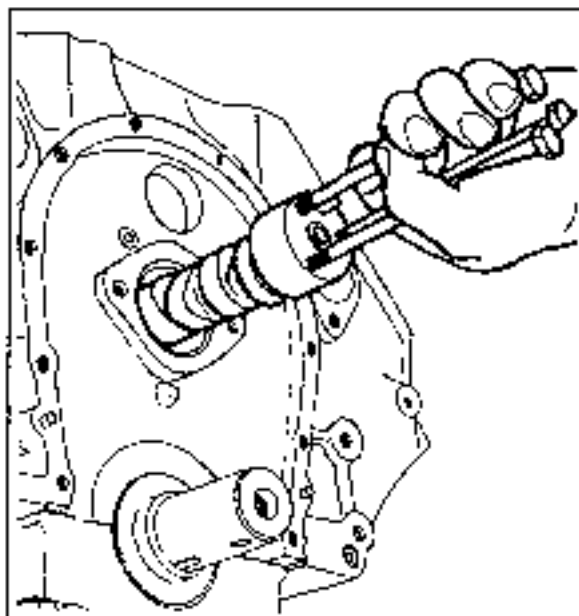

Replacing the Camshaft

IMPORTANT! Line up the timing marks on the camshaft sprocket and crankshaft sprocket as shown in "Timing Marks" figure.

IMPORTANT! Replace all hydraulic lifters, change the engine oil and filter and add a quality engine oil supplement to the engine oil whenever a new camshaft is installed.

Tighten:

- Bolts to 24 N•m (18 ft. lbs.)

Adjust:

- Valves, as outlined previously.

9. Intake manifold, as outlined previously.
10. Distributor. (See "Engine Electrical" section in this manual.)
11. Front cover, as outlined previously.
12. Torsional damper, as outlined previously.
13. Water pump.
14. Frame arrestor and weather cover.
15. Battery negative cable.
 - Fill the cooling system with the proper quantity and grade of coolant.

CONNECTING ROD AND PISTON REPLACEMENT

Remove or Disconnect:

Tool required:
J-5239 Guide Set

1. Engine from boat, as outlined later.
2. Cylinder head, as outlined previously.
3. Oil pan, as outlined previously.
4. Oil pump, as outlined previously (if necessary).
5. Ridge or deposits from the upper end of the cylinder bores.
 - Turn the crankshaft until the piston is at the BDC.
 - Place a cloth on top of the piston.
 - Perform the cutting operation with a ridge reamer.
 - Turn the crankshaft until the piston is at TDC.
 - Remove the cloth and cuttings.
6. Connecting rod cap. Check the connecting rod and cap for identification marks. Mark the parts if required. The connecting rod and cap must be kept together as mating parts.
7. Connecting rod and piston.
 - Attach J-5239 to the connecting rod bolts.
 - Use the long guide rod of J-5239 to push the connecting rod and piston out of the bore.
8. Connecting rod bearing.

Cleaning, Inspection and Repair:

- Clean, inspect and repair or replace the components as necessary. Measure connecting rod bearing clearance, piston clearance, ring clearances, etc.

Install or Connect:

Tools required:
J-5239 Connecting Rod Guide Set
J-8037 Ring Compressor

- Make sure the cylinder walls are clean.

- Lubricate the cylinder wall lightly with engine oil.

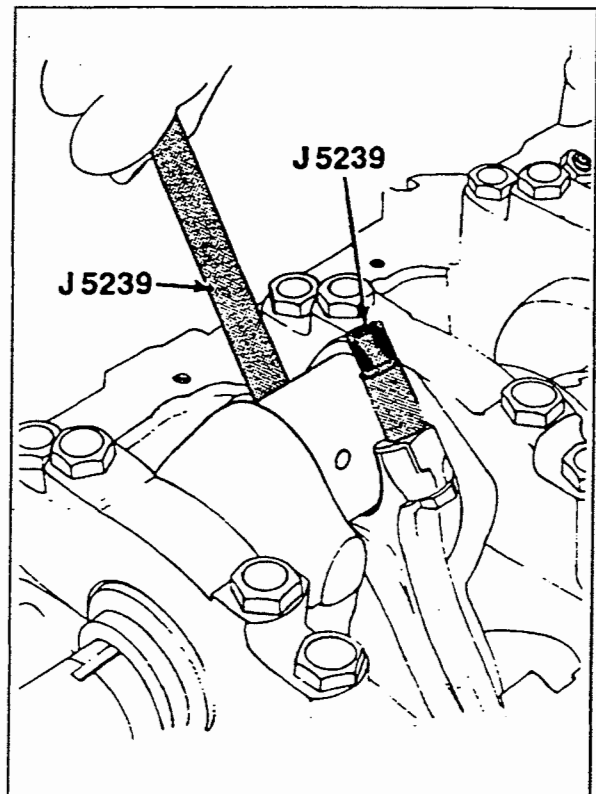

Replacing the Piston and Connecting Rod

- Make sure the piston is installed in the matching cylinder.
1. Connecting rod bearings.
 - Be certain that the bearings are of the proper size.
 - Install the bearings in the connecting rod and connecting rod cap.
 - Lubricate the bearings with engine oil.
 2. Piston and connecting rod to the proper bore.
 - With the connecting rod cap removed, install J-5239 onto the connecting rod studs.
 - Locate the piston ring end gaps as shown in next figure. Lubricate the piston and rings.
 - Without disturbing the ring end gap location, install J-8037 over the piston.
 - The piston must be installed so that the notch in the piston faces the front of the engine.

CONNECTING ROD AND PISTON REPLACEMENT (Continued)

- Place the piston in its matching bore. The connecting rod bearing tang slots must be on the side opposite the camshaft. Using light blows with a hammer handle, tap the piston down into its bore. At the same time, from beneath the vehicle guide the connecting rod to the crankpin with J-5239. Hold the ring compressor against the block until all rings have entered the cylinder bore.

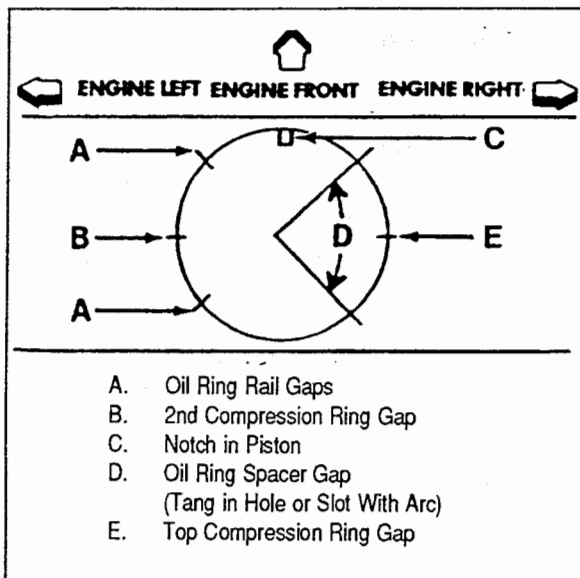

Piston Ring End Gap Locations

- Remove J-5239 from the connecting rod bolts.

IMPORTANT! Each connecting rod and bearing cap should be marked, beginning at the front of the engine. Cylinders 1, 3, 5 and 7 are the left bank and 2, 4, 6 and 8 are the right bank. The numbers on the connecting rod and bearing cap must be on the same side when installed in the cylinder bore. If a connecting rod is ever transposed from one block or cylinder to another, new connecting rod bearings should be fitted and the connecting rod should be numbered to correspond with the new cylinder number.

Measure:

- Connecting rod bearing clearance.

- Connecting rod cap and bearing.
- Connecting rod cap nuts.

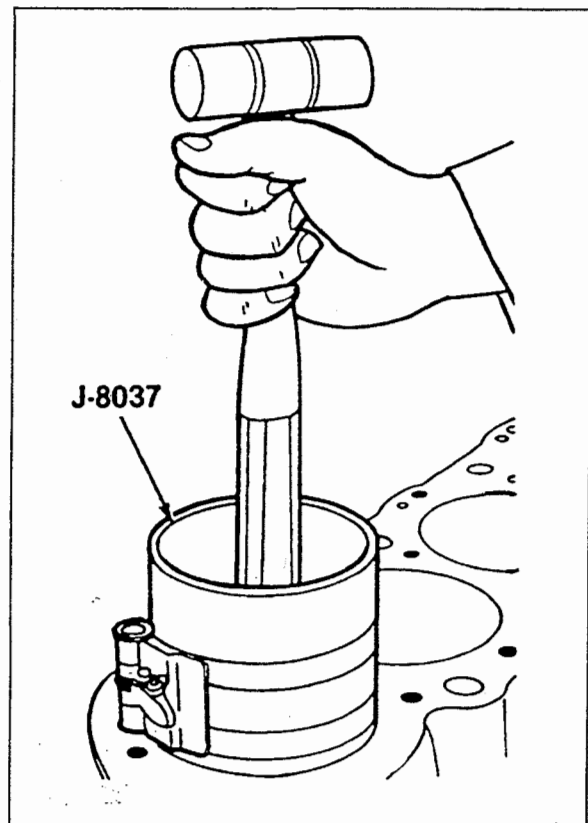

Installing the Piston

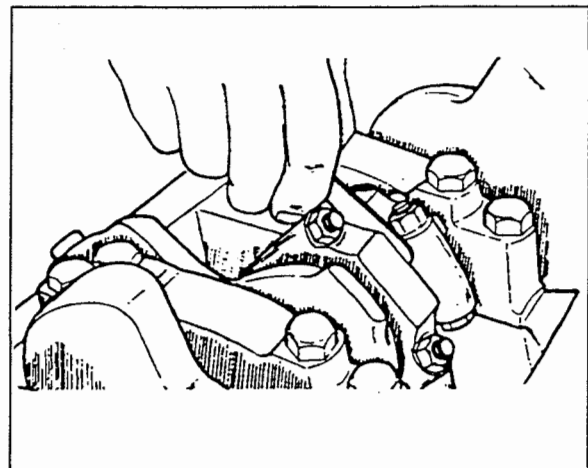

Measuring Connecting Rod Side Clearance

Tighten:

- Connecting rod cap nuts to 60 N·m (45 ft.lbs.)

CONNECTING ROD AND PISTON REPLACEMENT (Continued)

Measure:

- Connecting rod side clearance. Use a feeler gauge between the connecting rods. The correct clearance is 0.006-0.014-inch.
5. Oil pump (if removed), as outlined previously.
 6. Oil pan and cylinder head, as outlined previously.

OIL FILTER ADAPTER AND OIL FILTER BYPASS VALVE REPLACEMENT

Remove or Disconnect:

1. Oil filter or remote bypass.

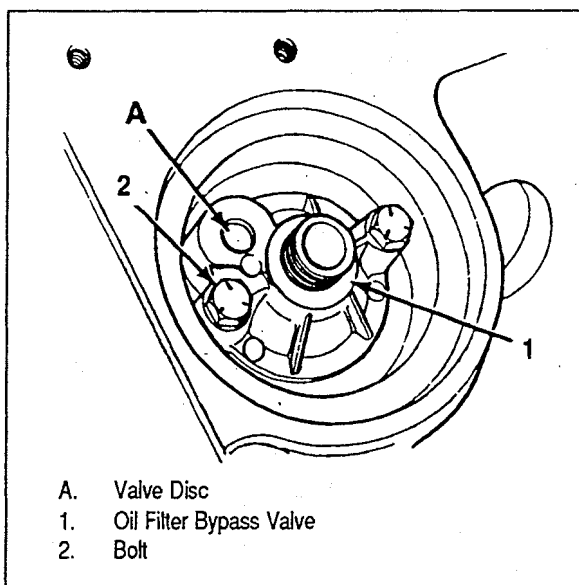

- A. Valve Disc
1. Oil Filter Bypass Valve
2. Bolt

Oil Filter Bypass Valve

Inspect:

- Bypass valve spring and valve disc for proper operation, cracks, and damage. If replacement is needed, the oil filter bypass valve must be replaced, as follows:
2. Bolts.
 3. Oil filter bypass valve.

Clean:

- Valve chamber in the block.

Install or Connect:

1. Oil filter bypass valve.
2. Bolts.

Tighten:

- Bolts to 26 N•m (20 ft.lbs.)
3. Oil filter.
 4. Engine oil, as needed.

MAIN BEARING REPLACEMENT

Remove or Disconnect:

Tool required:

J-8080 Main Bearing Remover/Installer

1. Spark plugs.
2. Oil pan, as outlined previously.
3. Oil pump, as outlined previously.
4. Main bearing caps.

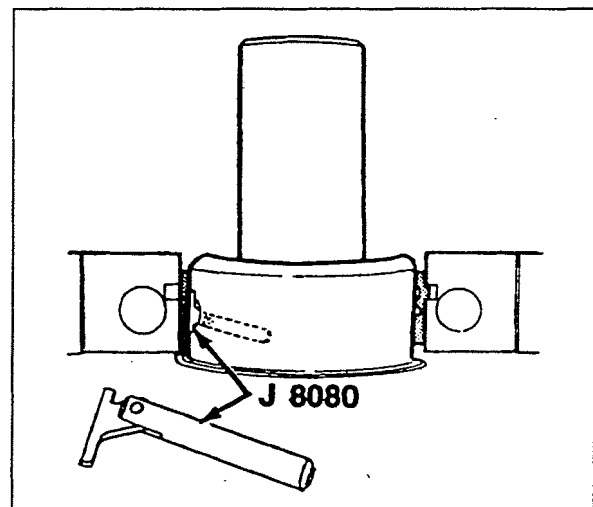

Removing the Main Bearing Insert

- Check the main bearing caps for location markings. Mark the caps if necessary. The caps must be returned to their original locations during assembly.

MAIN BEARING REPLACEMENT (Continued)

5. Lower main bearing inserts from the main bearing caps.
6. Upper main bearing inserts.
 - Insert J-8080 into the crankshaft oil hole.
 - Rotate the crankshaft to "turn" the bearing insert out of the block.

Cleaning, Inspection and Repair:

- Clean, inspect and repair the components as required.

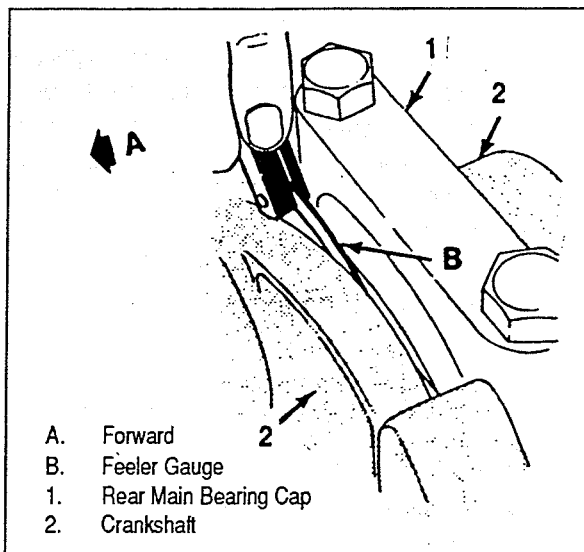
**Measuring Crankshaft End Play****Install or Connect:**

Tool required:

J-8080 Main Bearing
Remover/Installer

1. Upper main bearing inserts.
 - Insert tool J-8080 into a crankshaft main bearing oil hole.
 - Apply engine oil to inserts of the proper size.
 - Insert the plain end (without the bearing tang) of the insert between the crankshaft and the notched side of the block.
 - Rotate the crankshaft to "roll" the insert into the block.
 - Remove the tool.

2. Lower main bearing inserts to the main bearing caps.
 - Make sure the inserts are the proper size.
 - Apply engine oil to the inserts.

Measure:

- Main bearing clearance.

3. Main bearing caps (except rear cap) and bolts to the block.

Tighten:

- Main bearing cap bolts to specifications.
 - Outer bolts on #2, #3 and #4 main bearing caps: 95 N•m (70 ft.lbs.)
 - All others 110 N•m (80 ft.lbs.)

4. Rear main bearing cap and bolts.

Tighten:

- Rear main bearing cap bolts temporarily to 14 N•m (10 ft.lbs.).

Measure:

- Crankshaft end play as follows:
 - Tap the end of the crankshaft first rearward then forward with a lead hammer. This will line up the rear main bearing and crankshaft thrust surfaces.
 - Tighten the rear main bearing cap bolts to 110 N•m (80 ft.lbs.).
 - With the crankshaft forced forward, measure at the front end of the rear main bearing with a feeler gauge. The proper clearance is 0.002-0.006-inch.
 - If correct end play cannot be obtained, be certain that the correct size rear main bearing has been installed. Production engines may have rear main bearings that are 0.008-inch wider across the thrust faces than standard.

8. Oil pump, as outlined previously.
9. Oil pan, as outlined previously.
10. Spark plugs.

CRANKSHAFT REPLACEMENT

1. Remove the engine, as outlined later.
2. Remove engine components, as necessary.

Remove or Disconnect:

1. Oil pan, as outlined previously.
2. Oil pump, as outlined previously (if necessary).
3. Connecting rod caps. Check the connecting rod and cap for identification marks. Mark the parts if required. The connecting rod and cap must be kept together as mating parts.
4. Main bearing caps. Check the main bearing caps for location markings. Mark the caps if necessary. The caps must be returned to their original locations during assembly.
5. Remove crankshaft.

CRANKSHAFT AND MAIN BEARING INSTALLATION

NOTE: PRIOR TO ASSEMBLY, the importance of cleanliness during the assembly procedure cannot be overstressed. Dirt will cause premature wear of the rebuilt engine. Lubricate all moving parts lightly with engine oil or engine assembly lubricant (unless specified otherwise) during assembly. This will provide initial lubrication when the engine is started.

Main bearings are of the precision insert type and do not use shims for adjustment. If clearances are excessive, a new bearing will be required. Service bearings are available in standard size and 0.001 inch, 0.002 inch, 0.010 inch, and 0.020 inch undersize. 0.009 inch is available for 5.0L and 5.7L engines only.

Selective fitting of both rod and main bearing inserts is necessary to obtain close tolerances. For this reason you may use, for example, one half of a 0.001 inch undersize insert which will decrease the clearance 0.0005 inch from using a full standard bearing.

UNDERSIZE MAIN JOURNALS

(5.0L and 5.7L ENGINES)

- On 5.0L and 5.7L engines, when a production crankshaft cannot be precision fit by the method described previously, it is then ground 0.009 inch undersize **ON ONLY THOSE MAIN JOURNALS THAT CANNOT BE PROPERLY FITTED. ALL JOURNALS WILL NOT NECESSARILY BE GROUND.** A 0.009 inch undersize bearing or 0.010 inch undersize bearing will then be used for precision fitting in the same manner as previously described.

OVERSIZE REAR MAIN BEARING THRUST FACES

(5.0L and 5.7L ENGINES)

- Some 5.0L and 5.7L production engines may have rear main bearings that are 0.008 inch wider than standard across the thrust faces.
- The crankshaft on these engines can be identified by ".008" stamped on the rear counterweight.
- If the rear main bearings are replaced, they must have the proper distance between thrust faces to obtain correct crankshaft end play.

Install or Connect:

NOTICE: For steps 4 and 5, see "Notice" on Fasteners on page 12-2.

1. Upper main bearing inserts to the block.

IMPORTANT! If any undersized bearings are used, make sure they are fitted to the proper journals.

2. Crankshaft.
3. Lower main bearing inserts to the main bearing caps.

Measure:

- Main bearing clearance. (See "Mechanical Procedures" section in this manual.)
- Apply engine oil to the main bearing inserts.

**CRANKSHAFT AND MAIN BEARING
INSTALLATION (Continued)**

- 4. Main bearing caps (except rear caps) and bolts to the block.

Tighten:

- Main bearing cap bolts to specifications.
- 5.0L and 5.7L engines:
 - Outer bolts on #2, #3 and #4 main bearing caps: 95 N•m (70 ft.lbs.)
 - All others: 110 N•m (80 ft.lbs.)

- 5. Rear main bearing cap and bolts to the block.

Tighten:

- Rear main bearing cap bolts temporarily to 14 N•m (124 in.lbs.)

Measure:

- Crankshaft end play, as follows:
 - A. Tap the end of the crankshaft first rearward then forward with a lead hammer. This will line up the rear main bearing and crankshaft thrust surfaces.

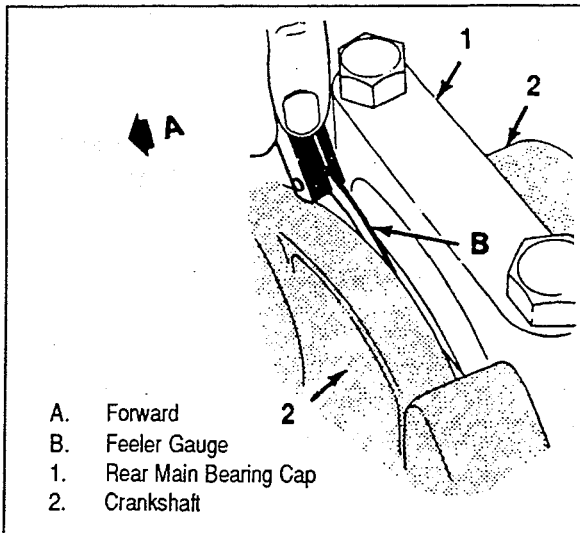

Measuring Crankshaft End Play

Tighten:

- Rear main bearing cap bolts to specifications:

- 5.0L and 5.7L engines: 100 N•m (80 ft.lbs.)
- B. With the crankshaft forced forward, measure at the front end of the rear main bearing with a feeler gauge. The proper clearance is 0.002-0.006 inch.

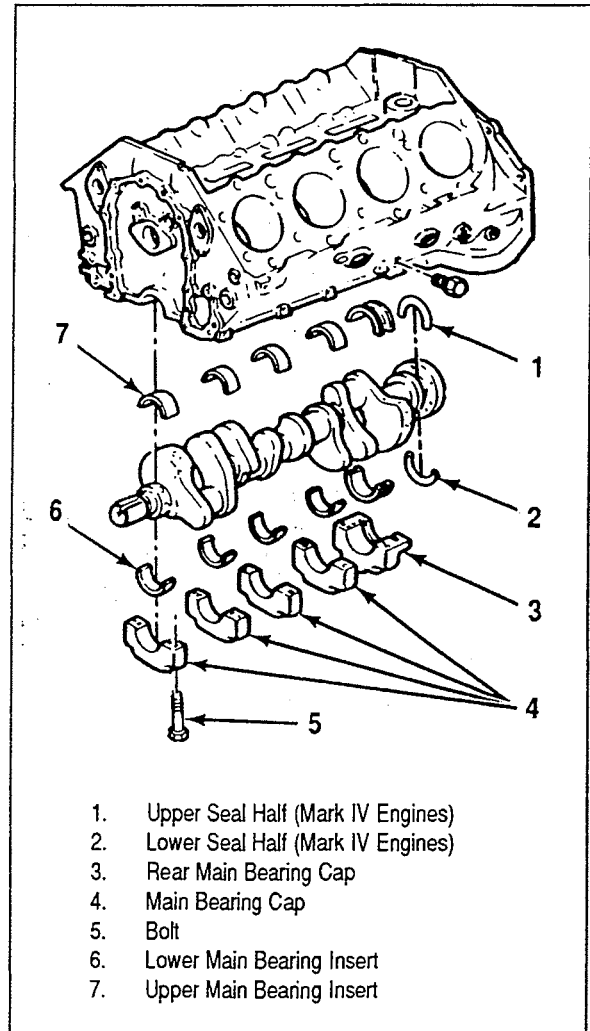

- 1. Upper Seal Half (Mark IV Engines)
- 2. Lower Seal Half (Mark IV Engines)
- 3. Rear Main Bearing Cap
- 4. Main Bearing Cap
- 5. Bolt
- 6. Lower Main Bearing Insert
- 7. Upper Main Bearing Insert

Crankshaft and Components

- C. On 5.0L and 5.7L engines, if correct end play cannot be obtained, make sure the correct size rear main bearing has been installed. Production engines may have rear main bearings that are 0.008 inch wider across the thrust faces than standard, as explained previously.

CRANKSHAFT AND MAIN BEARING INSTALLATION (Continued)

Inspect:

- Crankshaft for binding. Try turning the crankshaft to check for binding. If the crankshaft does not turn freely, loosen the main bearing cap bolts on one cap at a time until the tight bearing is located. Burrs on the bearing cap, foreign matter between the insert and the block or the bearing cap, or a faulty insert could cause a lack of clearance at the bearing.

FLYWHEEL REPLACEMENT

Remove or Disconnect:

1. Transmission, bellhousing and damper.
2. Flywheel bolts.
3. Flywheel.

Clean:

- Mating surfaces of crankshaft and flywheel. Remove any burrs.

Inspect:

- Flywheel for burning, scoring, warping and wear. Replace the flywheel if necessary. Do not machine the flywheel.
- Flywheel ring gear for worn or broken teeth.

FLYWHEEL RING GEAR REPLACEMENT

1. Use a torch to heat the gear around the entire circumference, then drive the gear off the flywheel, using care not to damage the flywheel.

NOTICE: Never heat starter gear to red hot as this will change metal structure.

2. Uniformly heat the flywheel gear to temperature

which will expand the gear to permit installation. Temperature must not exceed 204°C (400°F).

3. As soon as the gear has been heated, install on the flywheel.

Install or Connect:

1. Flywheel.
2. Flywheel bolts.

Tighten:

- Flywheel bolts to 100 N•m (75 ft.lbs.)
3. Damper (if used), bellhousing and transmission.

ENGINE REPLACEMENT

Remove or Disconnect:

1. Battery cables.
2. Heater hoses at the engine.
3. Throttle and shift linkage.
4. Power steering pump (if used) connections.
5. Engine wiring harness from the engine.
6. Fuel lines.
7. Exhaust hoses from the manifolds.
8. Water inlet hose.
9. Wiring, as necessary.
10. Coupling.
11. Front engine trunion mounts from isolators and transmission mount from isolators or stringers.
12. Engine.

Install or Connect:

1. Engine in the boat.
 - Support engine with suitable safety stands. •
- Align couplings (Sportpac) or engine (Enpac).
2. Engine mounts.
3. Coupling.
4. Wiring, as required.
5. Water inlet hose.
6. Exhaust hoses to the manifolds.
7. Fuel line.
8. Engine wiring harness.
9. Power steering pump connections (if used).

ENGINE REPLACEMENT (Continued)

10. Throttle and shift linkages. *NOTE: Make sure throttle and shift linkage is properly adjusted for full travel.*
11. Heater hoses.
12. Battery cables.

ENGINE SPECIFICATIONS

All specifications are in INCHES unless otherwise noted.

GENERAL DATA:					
Type		V8			
Displacement		5.0L (305 Cubic Inches)	5.7L (350 Cubic Inches)		
Bore		3.735	4.00		
Stroke		3.480			
Compressor Ratio		9.3	9.3		
Firing Order - Normal Rotation		1 - 3 - 4 - 3 - 6 - 5 - 7 - 2			
Firing Order - Reverse Rotation		1 - 2 - 7 - 5 - 6 - 3 - 4 - 8			
Oil Pressure		10 psi @ 500 rpm; 30-55 psi @ 2000 rpm			
CYLINDER BORE:					
Diameter		3.7350-3.7395	3.9995-4.0025		
Out of Round	Production	0.001 (Maximum)			
	Service	0.002 (Maximum)			
Taper	Production	Thrust Side	0.0005 (Maximum)		
		Retel Side	0.001 (Maximum)		
	Service	0.001 (Maximum)			
PISTON:					
Clearance	Production	0.0007-0.0017			
	Service Limit	0.0027 (Maximum)			
PISTON RING:					
C O M P R E S S I O N	Groove Clearance	Production	Top	0.0012-0.0032	
			2nd		
		Service Limit	Hi Limit Production +0.001		
	Gap	Production	Top	0.010-0.020	
			2nd	0.010-0.025	
		Service Limit	Hi Limit Production + 0.010		
O I L	Groove Clearance	Production	0.002-0.007		
		Service Limit	Hi Limit Production +0.001		
	Gap	Production	0.015-0.055		
		Service Limit	Hi Production +0.010		
PISTON PIN:					
Diameter		0.9260-0.9271			

ENGINE SPECIFICATIONS

All specifications are in INCHES unless otherwise noted.

PISTON PIN (Continued):				
Clearance In Piston	Production		0.0002-0.0007	
	Service Limit		0.001 (Maximum)	
Fit in Rod		0.0008-0.0016 Interference		
DISPLACEMENT		5.0L (305 Cubic Inches)	5.7L (350 Cubic Inches)	
CRANKSHAFT:				
Main Journal	Diameter	#1	2.4484-2.4493	
		#2, #3, #4	2.4481-2.4490	
		#5	2.4479-2.4488	
	Taper	Production		0.0002 (Maximum)
		Service Limit		0.001 (Maximum)
	Out of Round	Production		0.0002 (Maximum)
Service Limit		0.001 (Maximum)		
Main Bearing Clearance	Production	#1	0.0008-0.0020	
		#2, #3, #4	0.0011-0.0023	
		#5	0.0017-0.0032	
	Service Limit	#1	0.0010-0.0015	
		#2, #3, #4	0.0010-0.0025	
		#5	0.0025-0.0035	
Crankshaft End Play		0.002-0.006		
Crankpin	Diameter		2.0988-2.0998	
	Taper	Production	0.0005 (Maximum)	
		Service Limit	0.001 (Maximum)	
	Cut Round	Production	0.0005 (Maximum)	
Service Limit		0.001 (Maximum)		
Rod Bearing Clearance	Production		0.0013-0.0035	
	Service Limit		0.003 (Maximum)	
Rod Side Clearance		0.006-0.014		
CAMSHAFT:				
Lobe Lift \pm 0.002	Intake		0.2484	
	Exhaust		0.2667	
Journal Diameter		1.8682-1.8692		

ENGINE SPECIFICATIONS (Continued)















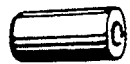

All specifications are in INCHES unless otherwise noted.

CAMSHAFT (Continued):			
Camshaft End Play		0.004-0.012	
VALVE SYSTEM:			
Lifter		Hydraulic	
Rocker Arm Ratio		1.50:1	
Valve Lash	Intake	One Turn Down From Zero Lash	
	Exhaust		
Face Angle (Intake & Exhaust)		45°	
Seat Angle (Intake & Exhaust)		46°	
Seat Runout (Intake & Exhaust)		0.002 (Maximum)	
Seat Width		Intake	1/32 - 1/16
		Exhaust	1/16 - 3/32
Stem Clearance	Production	Intake	0.0010-0.0027
		Exhaust	0.0010-0.0027
	Service	Intake	High Limit Production +0.001
		Exhaust	High Limit Production +0.002
Valve Spring (Outer)	Free Length		2.03
	Pressure lbs @ inch	Closed	76-84 lbs. @ 1.70"
		Open	194-206 lbs. @ 1.25"
	Installed Height \pm 1/32"		1-23/32
Valve Spring Damper	Free Length		1.86
	Approx. # of Coils		4

TORQUE SPECIFICATIONS

ITEM	N-m	Ft.Lbs.	In.Lbs.
Rocker Arm Cover Bolts	11.3		100
Intake Manifold Bolts	48	35	
Exhaust Manifold Bolts		Two Center Bolts	36
Exhaust Manifold Bolts		All Others	28
Cylinder Head Bolts	90	65	
Torsional Damper Bolt	95	70	
Front Cover Bolts	11.3		100
Oil Pan Nuts at Corners	22.6		200
Oil Pan Bolts	11.3		100
Oil Pump Bolt	90	65	
Rear Crankshaft Oil Seal Retainer Screws and Nuts	15.3		135
Camshaft Sprocket Bolts	24	18	
Connecting Rod Cap Nuts	60	45	
Oil Filter Bypass Valve Bolts	26	20	
Main Bearing Cap Bolts		Outer Bolts on #2, #3, #4 Caps	95
Main Bearing Cap Bolts		All Others	110
Oil Pump Cover Bolts	9.0		80
Flywheel Bolts	100	75	
Spark Plugs	30	22	
Water Outlet Bolts	28	21	
Water Pump Bolts	40	30	
Flywheel Housing Bolts	44	32	
Oil Pan Studs to Back or Rear Oil Seal Retainer	1.7		

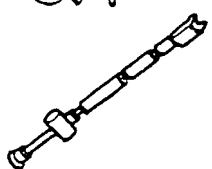
SPECIAL TOOLS

1.		J 23523-E	10.		J 3049-A
2.		J 5892-C	11.		J 5802-01
3.		J 23590	12.		J 5715
4.		J 35468	13.		J 6036
5.		J 8080	14.		J 6880
6.		J 8037	15.		J 5825-A
7.		J 5239	16.		J 5590
8.		J 23738-A	17.		J 8520
9.		J 9290-01	18.		J 35621

- | | |
|---|---|
| 1. Torsional Damper Remover and Installer | 10. Hydraulic Lifter Remover (Plier Type) |
| 2. Valve Spring Compressor | 11. Stud Remover |
| 3. Air Adapter | 12. Reamer (0.003-inch oversize) |
| 4. Crankshaft Seal Installer and Centering Tool | 13. Reamer (0.013-inch oversize) |
| 5. Main Bearing Replacer | 14. Stud Installer |
| 6. Piston Ring Compressor | 15. Crankshaft Gear Puller |
| 7. Guide Set | 16. Crankshaft Gear Installer |
| 8. Vacuum Pump | 17. Dial Indicator Adapter |
| 9. Hydraulic Lifter Remover (Slide Hammer Type) | 18. Rear Crankshaft Seal Installer |

ENGINES: 454/502 CID (7.4L-8.2L)

SECTION 13

INTRODUCTION.....	2
DESCRIPTION.....	2
ENGINE LUBRICATION.....	2
ENGINE LUBRICATION DIAGRAM.....	3
ROCKER ARM COVER REPLACEMENT.....	3
ROCKER ARM AND PUSHROD REPLACEMENT.....	4
VALVE STEM SEAL AND VALVE SPRING REPLACEMENT.....	5
INTAKE MANIFOLD REPLACEMENT.....	6
HYDRAULIC LIFTER REPLACEMENT.....	7
EXHAUST MANIFOLD REPLACEMENT.....	8
EXHAUST MANIFOLD RISER REPLACEMENT.....	9
CYLINDER HEAD REPLACEMENT.....	9
TORSIONAL DAMPER AND CRANKSHAFT FRONT SEAL REPLACEMENT.....	10
FRONT COVER REPLACEMENT.....	12
OIL PAN REPLACEMENT.....	12
OIL PUMP REPLACEMENT.....	13
CRANKSHAFT REAR OIL SEAL REPLACEMENT.....	14
MEASURING CAMSHAFT LOBE LIFT.....	14
CAMSHAFT REPLACEMENT.....	15
CONNECTING ROD AND PISTON REPLACEMENT.....	17
MAIN BEARING REPLACEMENT.....	19
CRANKSHAFT REPLACEMENT.....	20
FLYWHEEL REPLACEMENT.....	21
Flywheel Ring Gear Replacement.....	22
ENGINE REPLACEMENT.....	22
THREAD REPAIR.....	22
ENGINE SPECIFICATIONS CHART.....	24
TORQUE SPECIFICATIONS FOR FASTENER TIGHTENING.....	27
SPECIAL TOOLS.....	28

INTRODUCTION

The following "Notice" applies to one or more steps in the assembly procedure of components in this portion of the manual as indicated at appropriate locations by the terminology "NOTICE".

NOTICE: When fasteners are removed, always reinstall them at the same location from which they were removed. If a fastener needs to be replaced, use the correct part number fastener for that application. If the correct part number fastener is not available, a fastener of equal size and strength (or stronger) may be used. Fasteners that are not reused, and those requiring thread locking compound will be called out. The correct torque value must be used when installing fasteners that require it. If the above conditions are not followed, parts or system damage could result.

DESCRIPTION

454/502 CID (7.4L/8.2L) engines are 90° V8 type, overhead valve, liquid cooled, with cast iron block and heads.

The crankshaft is supported by five precision insert main bearings, with crankshaft thrust taken at the number five (rear) bearing.

The camshaft is supported by five plain type bearings and chain driven. Motion from the camshaft is transmitted to the valves by hydraulic lifters, pushrods, and ball type rocker arms. The valve guides are pressed in the cylinder head.

The pistons are cast aluminum alloy and the connecting rods are forged steel with precision insert type crankpin bearings. The piston pins are a press fit in the connecting rods and a floating fit in the piston.

ENGINE LUBRICATION

The gear type oil pump is driven from the distributor shaft, which is gear driven from the camshaft. Oil is drawn into the oil pump through a pickup screen and pipe.

Pressurized oil is routed to the oil filters. A bypass valve is provided to prevent excessive oil pressure. Filtered oil flows into the main galley and then to the camshaft and crankshaft bearings. The valve lifter oil gallery supplies oil to the valve lifters. Oil flows from the hydraulic lifters through the hollow pushrods to the rocker arms. Oil from the overhead drains back to the crankcase through oil drain holes.

The timing chain is drip fed from the front camshaft bearing. The pistons and piston pins are lubricated by oil splash.

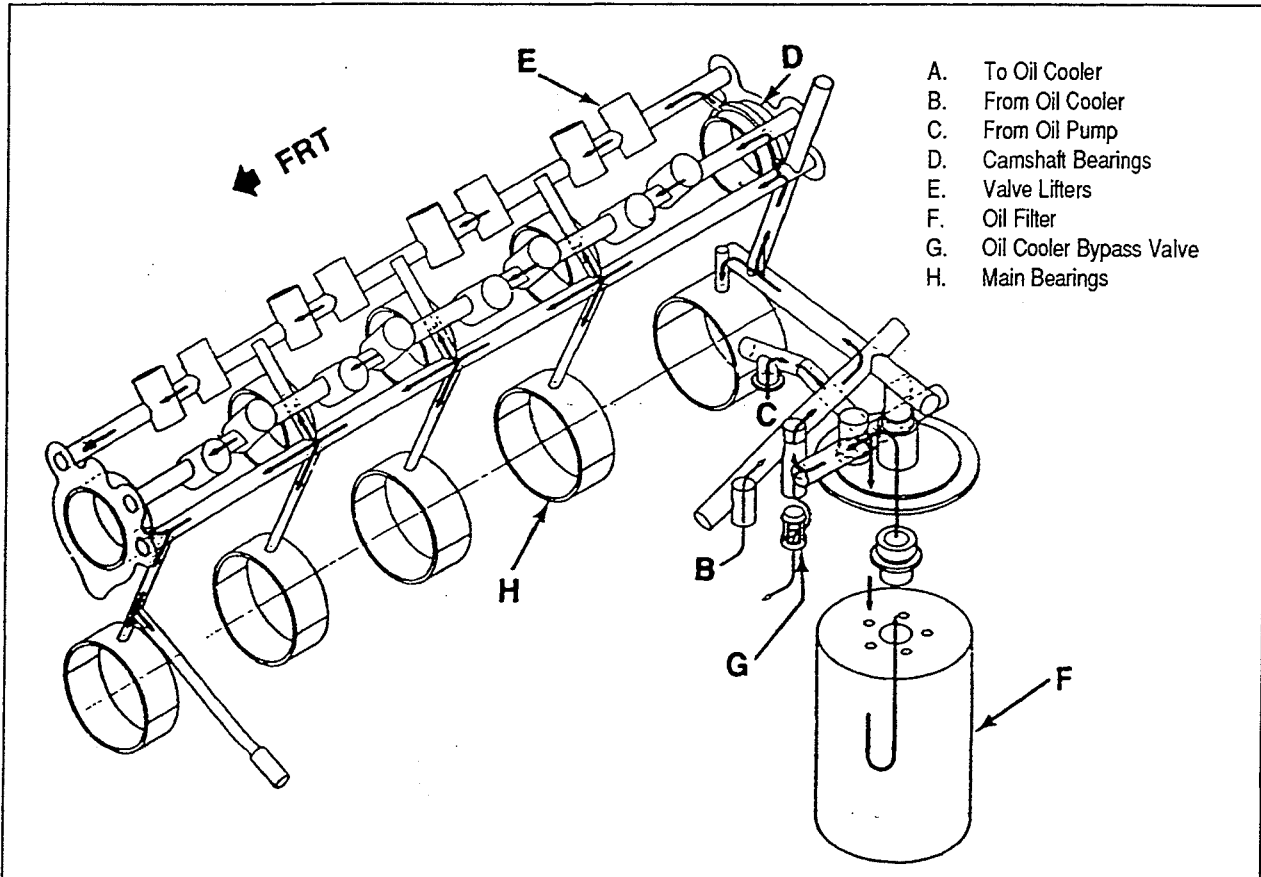

Engine Lubrication Diagram

ROCKER ARM COVER REPLACEMENT

Remove or Disconnect:

1. Battery negative cable.
2. Crankcase ventilation hoses.
3. Wiring harnesses from the clips and move aside.
4. Spark plug wire loom bracket at the rear of the cylinder head. Move the spark plug wire loom out of the way.
5. Components as follows, if necessary:
 - Exhaust riser
 - MAP sensor bracket
 - Fresh water coolant hoses. *NOTE: It may be necessary to partially drain system by removing plugs from rear of exhaust manifolds. (See "Cooling Systems" section in this manual.)*

6. Rocker arm cover bolts and supports.
7. Rocker arm cover and gasket.

Clean:

- All traces of old gasket from the rocker arm cover and cylinder head.

Inspect:

- Rocker arm cover sealing surface for distortion. Replace if necessary.

Install or Connect:

1. Rocker arm cover and new gasket.

NOTICE: See "Notice" on page 13-2.

2. Supports and bolts.

ROCKER ARM COVER REPLACEMENT (Continued)**Tighten:**

- Bolts to 7 N•m (70 in.lbs.)
3. Spark plug wire loom bracket.
 4. Crankcase ventilation hoses.
 5. Refill coolant to proper level if previously drained.
 6. Negative battery cable.

ROCKER ARM AND PUSHROD REPLACEMENT**Remove or Disconnect:**

1. Rocker arm cover, as outlined previously.

2. Rocker arm with ball.

- If only the pushrod is to be replaced, back the rocker arm bolt off until the rocker arm can be swung away from the pushrod. Then pull the pushrod out.

3. Rocker arm with ball.
4. Pushrod and pushrod guide.

IMPORTANT! Store used components in order so they can be reassembled in the same location.

Inspect:

- Rocker arms and balls at their mating surfaces. These surfaces should be smooth and free from scoring or other damage.

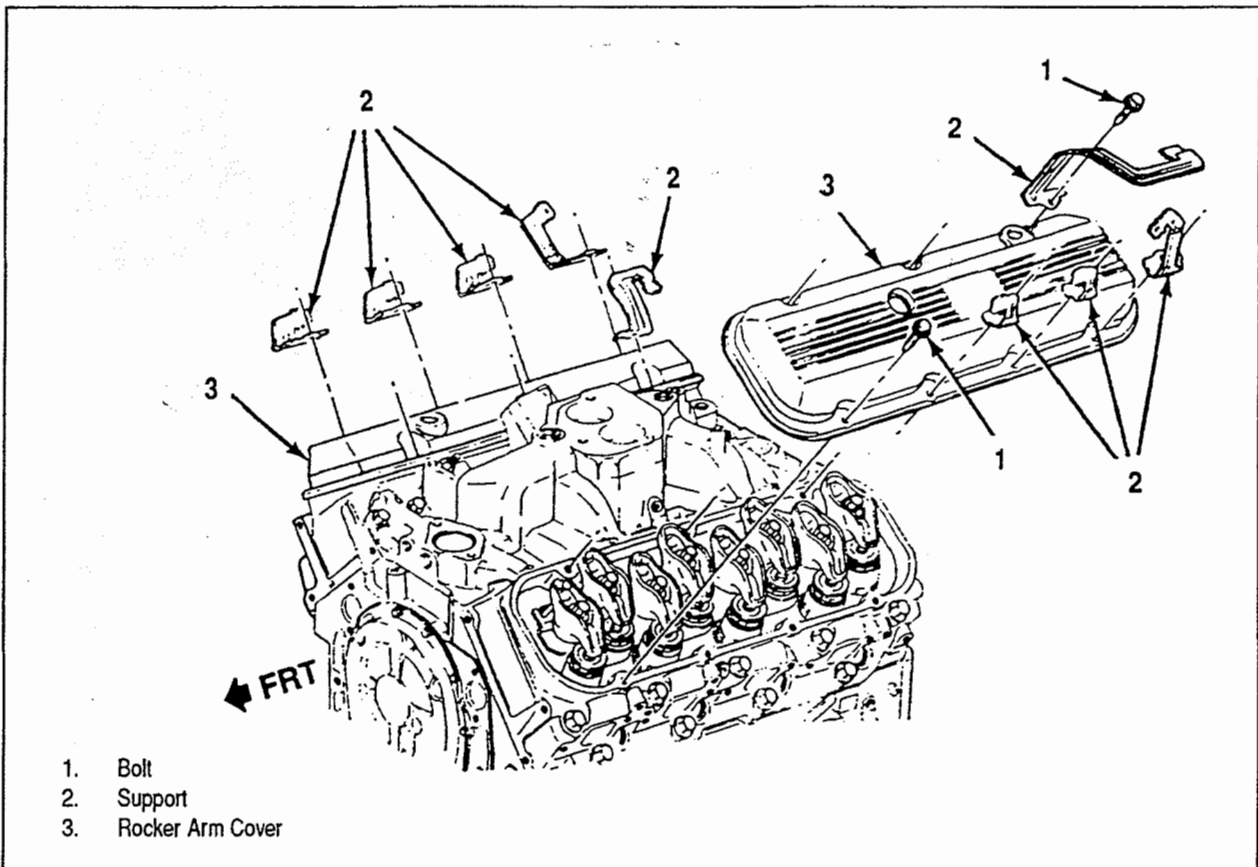
**Rocker Arm Cover**

**ROCKER ARM AND PUSHROD REPLACEMENT
(Continued)**

- Rocker arm areas that contact the valve stems and the sockets that contact the pushrods. These areas should be smooth and free of damage and wear.
- Pushrods for bending. Roll the pushrod on a flat surface to determine if it is bent. Replace if necessary.
- Ends of the pushrods for scoring and roughness.

Install or Connect:

1. Pushrod and pushrod guide. Make sure the pushrod seats properly in the hydraulic lifter.
2. Rocker arm with ball.

IMPORTANT! When new rocker arms and/or balls are installed, coat their bearing surfaces with high viscosity oil with zinc.

NOTICE: See "Notice" on page 13-2.

3. Rocker arm bolt.

Tighten:

- Bolt to 54 N•m (40 ft.lbs.)

4. Rocker arm cover, as outlined previously.

VALVE STEM SEAL AND VALVE SPRING REPLACEMENT

Remove or Disconnect:

Tools required:
 J-23590 Air Adapter
 J-5892-C Spring Compressor

1. Rocker arm cover, as outlined previously.

2. Rocker arms, as outlined previously.
3. Spark plugs.
4. Valve keepers.
 - A. Install J-23590 in the spark plug hole.
 - B. Apply compressed air to hold the valves in place.
 - C. Install a rocker arm bolt (see figure below).

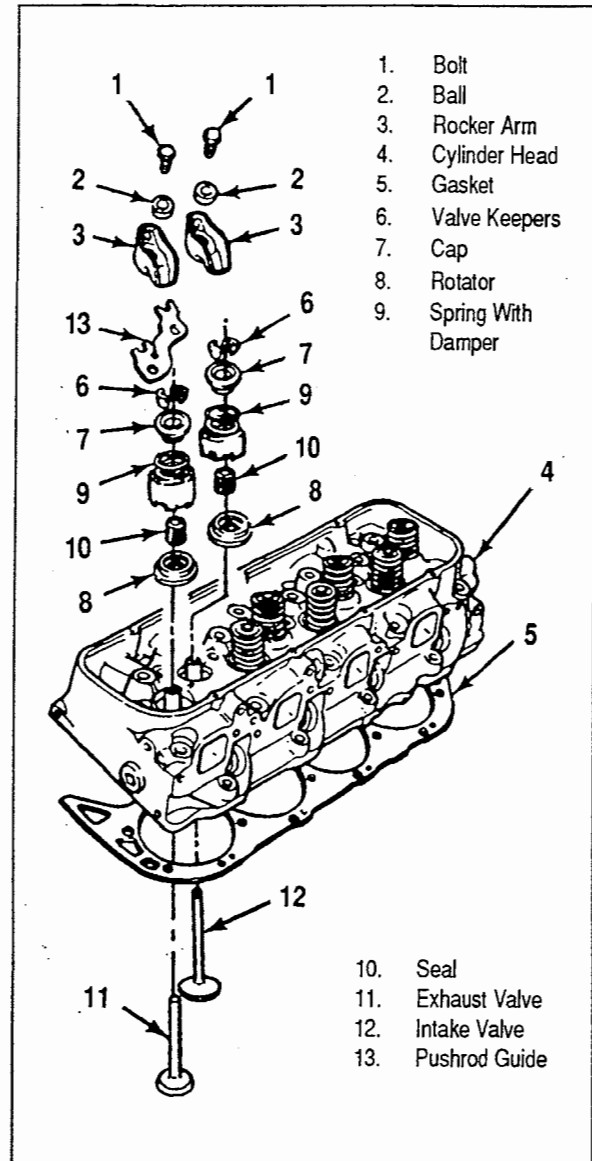

Cylinder Head and Components

- D. Use J-5892-C to compress the valve spring.
- E. Remove the valve keepers.
- F. Carefully release the spring tension. Remove J-5892-C.
5. Cap and spring with damper.

VALVE STEM SEAL AND VALVE SPRING REPLACEMENT (Continued)

6. Seal.

Install or Connect:

Tools required:

J-23590 Air Adapter

J-5892-C Spring Compressor

1. New seal. Install the seal over the valve stem and seat it against the head.
2. Spring with damper, and cap.

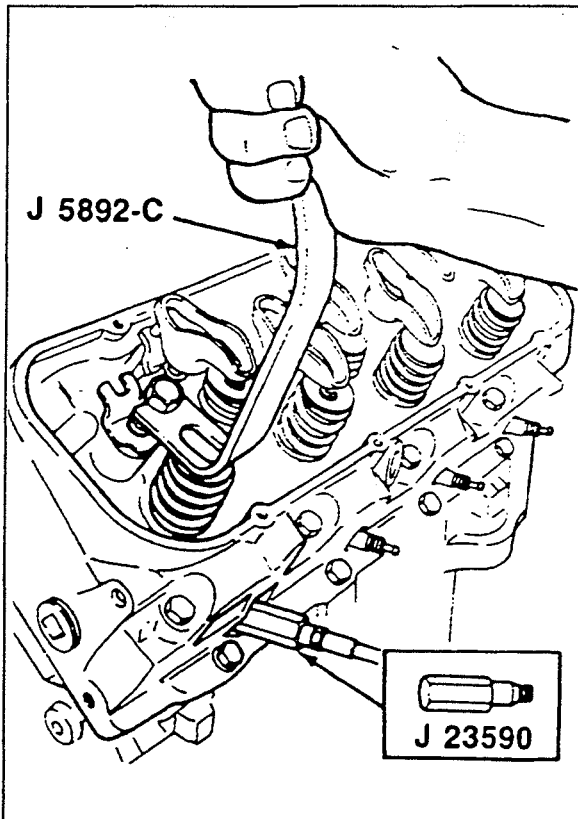
**Compressing the Valve Spring**

3. Valve keepers.
 - A. With air pressure applied to the cylinder with J-23590, compress the spring with J-5892-C.
 - B. Install the valve keepers. Use grease to hold them in place.
 - C. Carefully release spring pressure. Make sure the valve keepers stay in place.
 - D. Remove J-5892-C and J-23590.

4. Spark plugs.
5. Rocker arms, as outlined previously.
6. Rocker arm covers, as outlined previously.

INTAKE MANIFOLD REPLACEMENT**Remove or Disconnect:**

1. Battery negative cable.
2. Weather cover and flame arrestor.
 - Drain the cooling system. (See "Cooling Systems" section in this manual.)
3. Components as follows (if equipped):
 - Carburetor or TBI unit
 - MAP sensor bracket
 - Electrical component bracket
4. Cooling hoses.
5. Fuel lines.
6. Sensor wire at front of intake manifold.
7. Wiring harness from clips and move aside.
8. Crankcase ventilation hoses.
9. Vacuum hoses, as necessary.
10. Distributor. (See "Engine Electrical" section in this manual.)
11. Ignition coil wires.
12. Intake manifold bolts.
13. Intake manifold.
14. Gaskets and seals.

Clean:

- Old gaskets and seals from the block, heads, and intake manifold.
- Excessive carbon deposits from the exhaust and EGR passages.
- Excessive scale and deposits from the coolant passages.

Inspect:

- Manifold for cracks and gasket surface damage.

Install or Connect:

1. Front and rear intake manifold seals to the block.
2. Side gaskets to the cylinder heads.

INTAKE MANIFOLD REPLACEMENT (Continued)

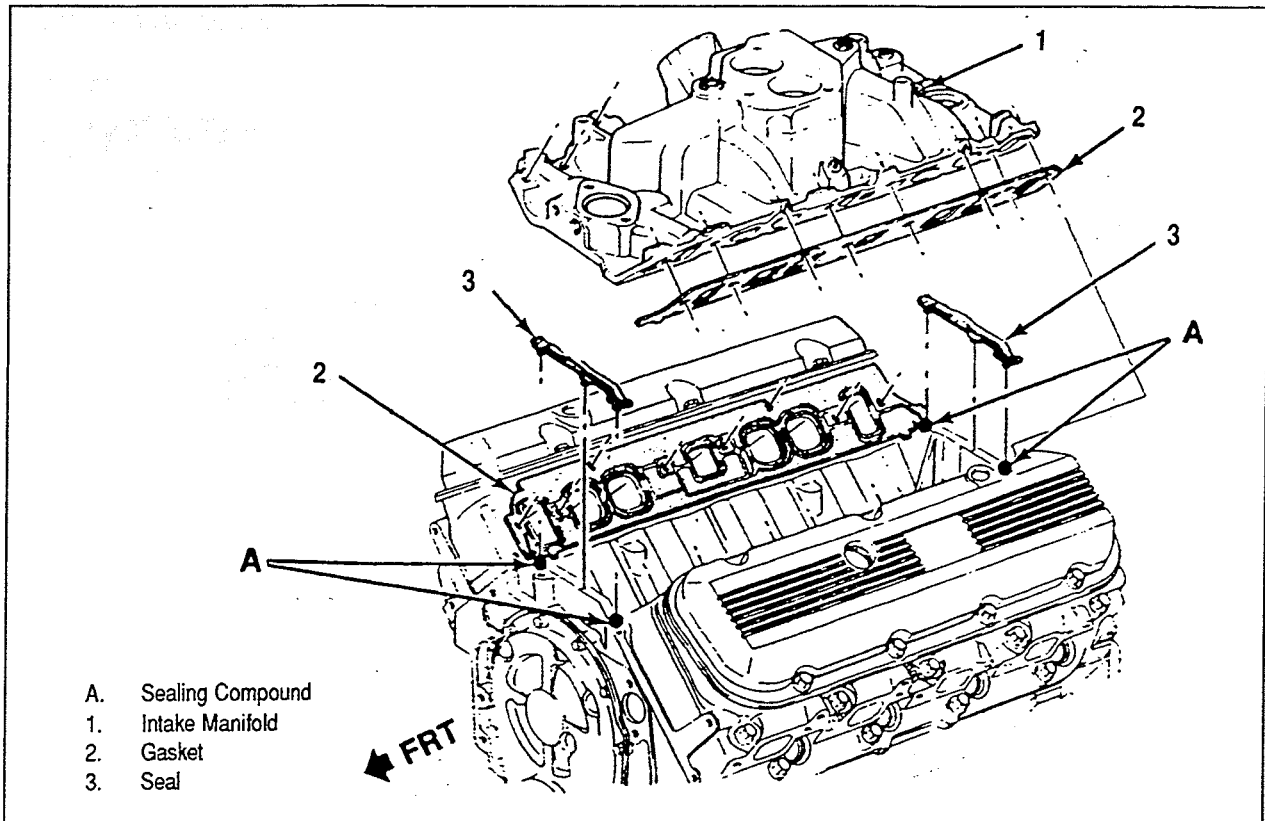

Intake Manifold

- Apply a 5 mm (3/16") spot of RTV sealer to the front and rear of the block in four places as shown in figure above.

NOTICE: See "Notice" on page 13-2.

- Intake manifold and bolts.

Tighten:

- Bolts to 40 N•m (30 ft.lbs.). Use the tightening sequence shown on previous page.
- Ignition coil wires.
 - Distributor.
 - Vacuum hoses, as necessary.
 - Crankcase ventilation hoses.
 - Wiring harness from clips and move aside.
 - Sensor wire at front of intake manifold.

- Fuel lines.
- Cooling hoses.
- Components as follows, if removed:
 - Carburetor or TBI unit
 - MAP sensor bracket
 - Electrical component bracket
- Flame arrestor and weather cover.
- Battery negative cable.
 - Fill the cooling system. (See "Cooling Systems" section in this manual.)

HYDRAULIC LIFTER REPLACEMENT**Remove or Disconnect:**

Tools required:

- J-3049-A Lifter Remover (Plier Type) or
- J-9290-01 Lifter Remover (Slide Hammer Type)

HYDRAULIC LIFTER REPLACEMENT

1. Rocker arm cover, intake manifold, and pushrod, as outlined previously.
2. Hydraulic lifters.
 - Remove the hydraulic lifters one at a time and place them in an organizer rack. The lifters must be installed in the same bore from which they were removed.
 - A stuck hydraulic lifter can be removed using J-3049-A or J-9290-01.

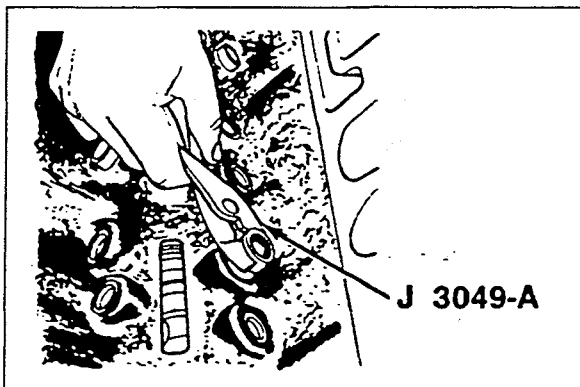

Removing the Valve Lifter

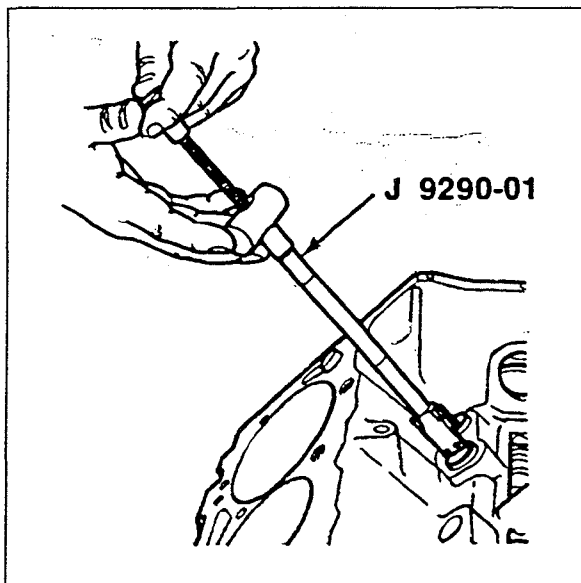

Removing the Valve Lifter

Inspect:

- Hydraulic lifter body for scuffing and scoring. If the lifter body wall is worn or damaged, the mating bore in the block should also be checked.

- Check the fit of each hydraulic lifter in its mating bore in the block. If the clearance is excessive, try a new lifter.
- The hydraulic lifter foot must be smooth and slightly convex. If worn, pitted, or damaged, the mating camshaft lobe should also be checked.

Install or Connect:

1. Hydraulic lifters in the block. Lubricate the lifter foot and body with high viscosity oil with zinc.

IMPORTANT! When any new hydraulic lifters or a new camshaft is installed, replace the engine oil and filter. High viscosity oil with zinc or equivalent should be added to the crankcase oil. Replace all hydraulic lifters when a new camshaft is installed.

2. Intake manifold, as outlined previously.
3. Pushrod, as outlined previously.
4. Rocker arm, ball and bolt, as outlined previously.
5. Rocker arm cover, as outlined previously.

EXHAUST MANIFOLD REPLACEMENT**Remove or Disconnect:**

1. Battery negative cable.
2. Coolant. (See "Cooling Systems" section in this manual.)
3. Dipstick tube.
4. Spark plugs.
5. Exhaust hose at the manifold/riser.
6. Exhaust manifold bolts.
7. Exhaust manifold.

Clean:

- Mating surfaces on the manifold and head.
- Threads on the exhaust manifold bolts.
- **NOTE:** In some cases, Permatex® sealant was used during original assembly. Gaskets currently available do not require sealant but surfaces must be clean.

EXHAUST MANIFOLD REPLACEMENT (Continued)**Install or Connect:**

1. Exhaust manifold.

NOTICE: See "Notice" on page 13-2.

2. Exhaust manifold bolts.

Tighten:

- Exhaust manifolds bolts to 54 N•m (40 ft.lbs.). Tighten the center bolts first, then continue outward each way.

3. Exhaust hose.
4. Spark plugs.
5. Dipstick tube.
6. Coolant. (See "Cooling Systems" section in this manual.)
7. Battery negative cable.

EXHAUST MANIFOLD RISER REPLACEMENT

Remove or Disconnect:

1. Battery negative cable.
2. Coolant from exhaust manifold. (See "Cooling Systems" section in this manual.)
3. Exhaust hose.
4. Riser bolts and lockwashers.
5. Riser.

Clean:

- Mating surfaces on the manifold and riser.
- Threads on the riser bolts.
- **NOTE:** In some cases, sealant was used during original assembly. Currently used gaskets do not require sealant but surfaces must be well cleaned.

Install or Connect:

1. Riser to exhaust manifold with new gasket.

2. Riser bolts and lockwashers. **NOTE:** Apply *Loctite® Threadlocker 242 sealant or equivalent to threads of bolts before installation.*

Tighten:

- Diagonal opposite riser bolts to 34 N•m (25 ft.lbs.)
- Remaining two riser bolts to 34 N•m (25 ft.lbs.)

3. Exhaust hose.
4. Coolant. (See "Cooling Systems" section in this manual.)
5. Battery negative cable.

CYLINDER HEAD REPLACEMENT

Remove or Disconnect:

1. Battery negative cable.
2. Intake manifold, as outlined previously.
3. Components as follows (if necessary):
 - Alternator bracket (port side only)
 - Fresh water cooling tank brackets
 - Fuel/water separator
 - Electric fuel pump.
4. Exhaust manifold, as outlined previously.
5. Rocker arm cover, as outlined previously.
6. Spark plugs.
7. Pushrods, as outlined previously.
8. Cylinder head bolts.
9. Cylinder head.
10. Head gasket.

Clean:

- Carbon deposits from combustion chambers.
- All traces of old head gasket from cylinder head and block.
- Cylinder head bolt threads and threads in the block.

Inspect:

- Sealing surfaces of the block and cylinder head for nicks, heavy scratches or other damage.

CYLINDER HEAD REPLACEMENT (Continued)**Install or Connect:**

1. Head gasket.
 - Use only marine gasket.
 - Place the gasket over the block dowel pins with the bead up.
2. Cylinder head. Carefully guide the cylinder head into place over the dowel pins and gasket.

NOTICE: See "Notice" on page 13-2.

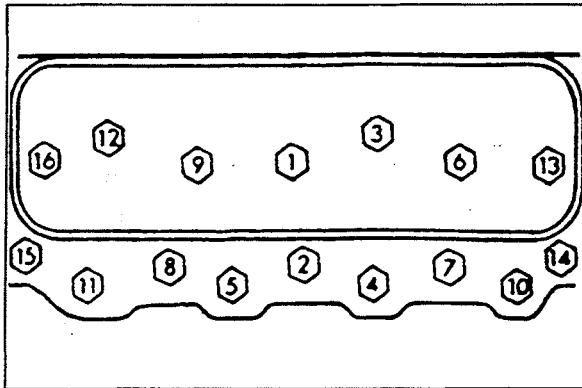

Cylinder Head Bolt Tightening Sequence

3. Cylinder head bolts. Coat threads of the cylinder head bolts with sealing compound and install finger-tight.

Tighten:

- Cylinder head bolts in three steps using the sequence shown above.
 - The first sequence to 40 N•m (30 ft.lbs.)
 - The second sequence to 80 N•m (60 ft.lbs.)
 - The final torque sequence to 110 N•m (80 ft.lbs.)
4. Pushrods, as outlined previously.
 5. Rocker arms, balls, and bolts as outlined previously.
 6. Rocker arm cover, as outlined previously.
 7. Spark plugs.
 8. Exhaust manifold, as outlined previously.

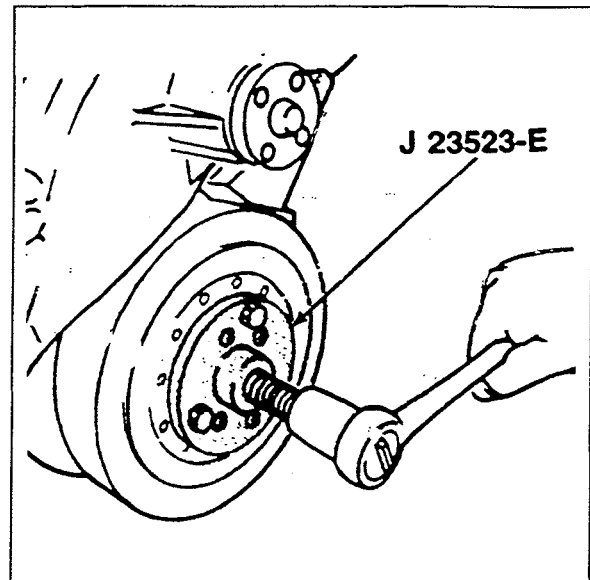

Removing the Torsional Damper

9. Components as follows (if removed):
 - Alternator bracket
 - Fresh water cooling tank bracket(s)
 - Fuel/water separator
 - Electric fuel pump
10. Intake manifold, as outlined previously.
11. Battery negative cable.

**TORSIONAL DAMPER AND
CRANKSHAFT FRONT SEAL
REPLACEMENT**

Remove or Disconnect:

Tool required:

J-23523-E Torsional Damper Puller and Installer

1. Battery negative cable.
2. Alternator belt(s) and crankshaft pulley.
3. Torsional damper bolt.
4. Torsional damper. Use J-23523-E.
5. Crankshaft front seal. Pry out with a large screwdriver. Take care not to distort the front cover.
6. Crankshaft key, if necessary.

TORSIONAL DAMPER AND CRANKSHAFT FRONT SEAL REPLACEMENT (Continued)

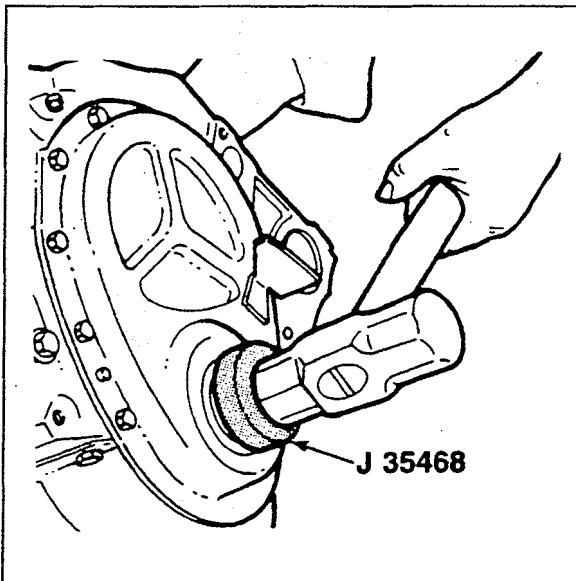

Installing the Crankshaft Front Seal

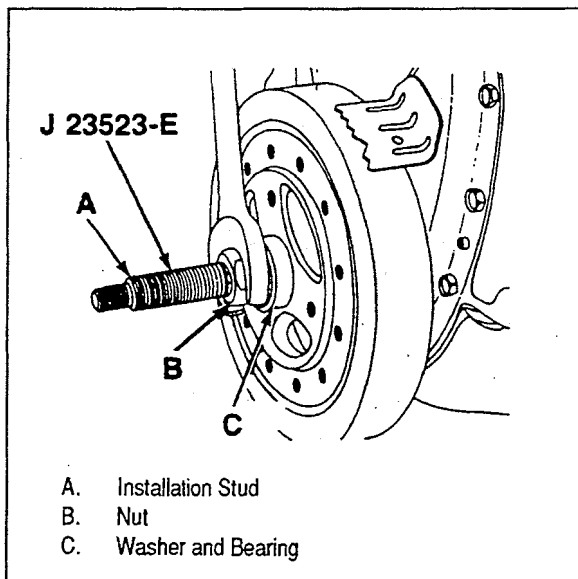

Installing the Torsional Damper

Inspect:

- Oil seal contact area on the torsional damper shaft for grooving and roughness. Replace if necessary.

Install or Connect:

Tools required:

J-22102 Seal Installer

J-23523-E Torsional Damper Puller and Installer

1. Crankshaft key, if removed.
2. Crankshaft front seal. Use J-22102. The open end of the seal faces inside the engine. Coat the seal lips with engine oil.

NOTICE: The inertial weight section of the torsional damper is assembled to the hub with a rubber type material. The correct installation procedures (with the proper tool) must be followed or movement of the inertial weight section of the hub will destroy the tuning of the torsional damper.

3. Stud (item A in previous figure) to the crankshaft. Thread the stud fully into the tapped hole in the crankshaft.
4. Torsional damper over the end of the stud. Align the keyway in the torsional damper shaft with the crankshaft key.
 - Use a small amount of RTV sealer to seal the crankshaft key to crankshaft joint.
5. Bearing, washer, and nut.
 - Turn the nut to pull the vibration damper into place.
 - Remove the tool.

NOTICE: See "Notice" on page 13-2.

6. Torsional damper bolt and washer.

Tighten:

- Bolt to 115 N•m (85 ft.lbs.)

7. Crankshaft pulley and alternator belt(s).
8. Battery negative cable.

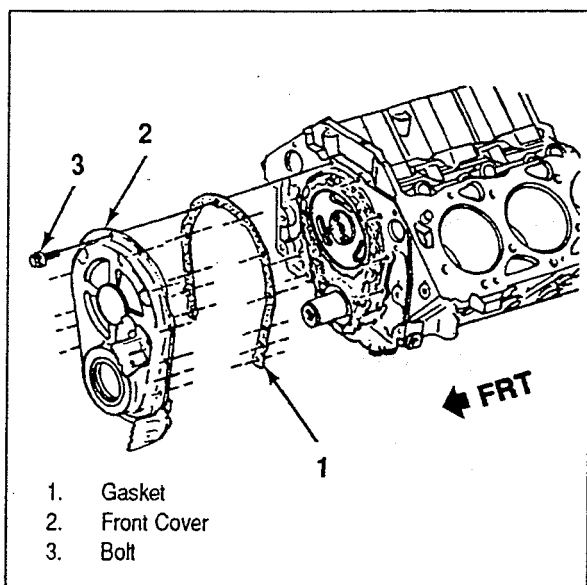
TORSIONAL DAMPER AND CRANKSHAFT FRONT SEAL REPLACEMENT (Continued)

Front Cover

FRONT COVER REPLACEMENT**Remove or Disconnect:**

1. Torsional damper, as outlined previously.
2. Coolant pump.
3. Oil pan, as outlined later in this section.
4. Front cover bolts.
5. Front cover.
6. Front cover to block gasket.
7. Crankshaft front seal from the front cover. Pry out with a screwdriver. Take care not to distort the front cover.

Clean:

- Old gasket from the front cover and block.

Inspect:

- Front cover for distortion and damage. Replace if necessary.

Install or Connect:

Tool required:

J-22102 Seal Installer

1. Crankshaft front seal. Use J-22102. The open end of the seal faces inside the engine. Coat the seal lips with engine oil.
2. Front cover gasket to the front cover. Use gasket cement to hold it in place.

NOTICE: See "Notice" on page 13-2.

3. Front cover and bolts to the engine.

Tighten:

- Front cover to block bolts to 11 N·m (100 in.lbs.)
4. Oil pan, as outlined later in this section.
 5. Coolant pump. (See "Cooling Systems" section in this manual.)
 6. Torsional damper, as outlined previously.

OIL PAN REPLACEMENT**Remove or Disconnect:**

1. Battery negative cable.
2. Distributor cap.
 - Raise the engine if necessary. Support with a suitable lifting fixture. **NOTE:** In some cases, it may be necessary to remove engine from boat.
 - Drain the engine oil.
 - Raise the engine only enough to permit oil pan removal.
3. Oil pan bolts.
4. Oil pan.
5. Gasket.

NOTICE: When raising or supporting the engine for any reason, do not use a jack under the oil pan, any sheet metal or crankshaft pulley. Due to the small clearance between the oil pan and the oil pump screen, jacking against the oil pan may cause it to be bent against the pump screen, resulting in a damaged oil pickup unit.

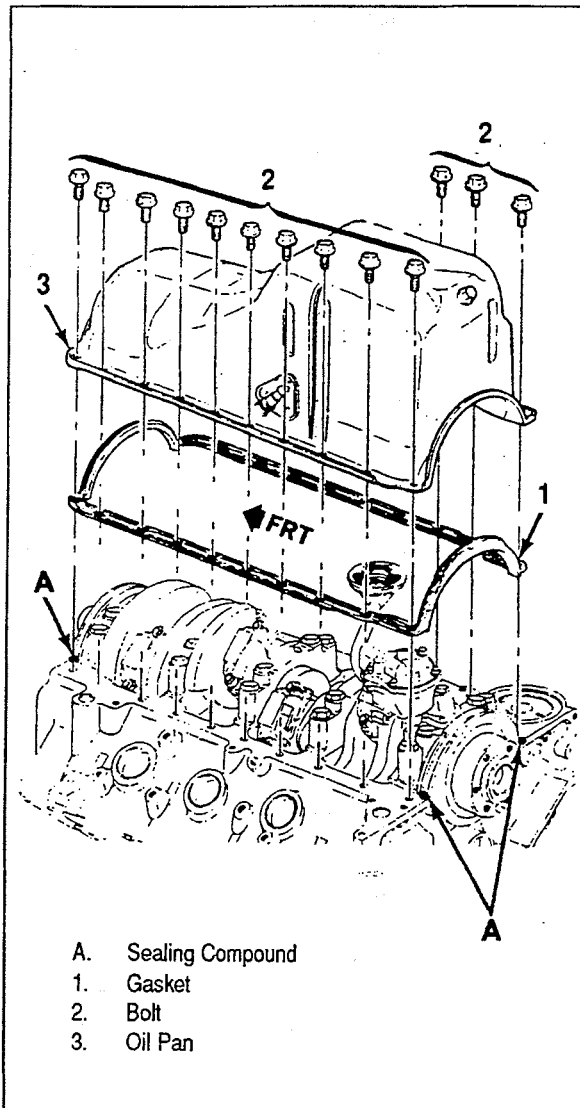
OIL PAN REPLACEMENT (Continued)

- A. Sealing Compound
 1. Gasket
 2. Bolt
 3. Oil Pan

Oil Pan**Clean:**

- Gasket surfaces on the engine and oil pan.

Install or Connect:

NOTICE: For steps 3 and 4, see "Notice" on page 12-2.

- Apply RTV sealer to the front and rear corners of the gasket as shown in previous figure.

- Oil pan gasket to the oil pan.
- Oil pan to the engine.
- Oil pan bolts.

Tighten:

- Oil pan to block bolts to 18 N•m (13 ft.lbs.)
- Lower the engine, if necessary.

- Distributor cap.
- Proper quantity and grade of engine oil.
- Battery negative cable.

OIL PUMP REPLACEMENT**Remove or Disconnect:**

- Oil pan, as outlined previously.
- Oil pump to main bearing cap bolt.
- Oil pump.

Inspect:

- Oil pump pickup tube and screen for damage and looseness. If the tube is loose or damaged, the oil pump must be replaced. The pickup tube and screen are not serviced separately.

Install or Connect:

- Oil pump to the engine.
 - Align the slot in the oil pump shaft with the tang on the distributor shaft. The oil pump should slide easily into place. No gasket is used.

NOTICE: See "Notice" on page 13-2.

- Oil pump to main bearing cap bolt.

Tighten:

- Oil pump bolt to 90 N•m (65 ft.lbs.)

- Oil pan, as outlined previously.

CRANKSHAFT REAR OIL SEAL REPLACEMENT

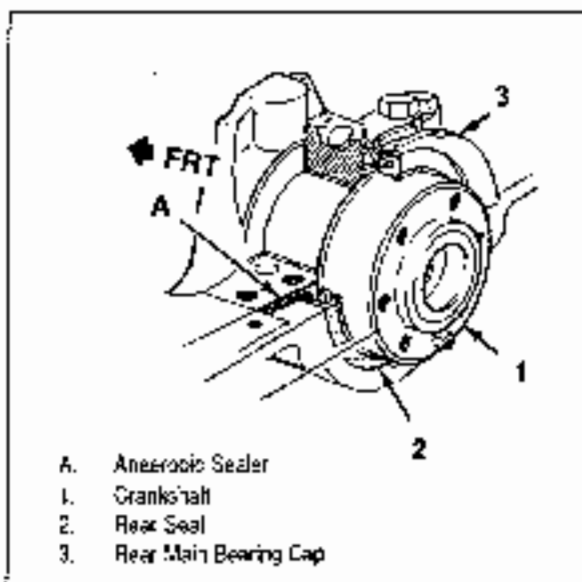

- A. Aneroptic Sealer
 1. Crankshaft
 2. Rear Seal
 3. Rear Main Bearing Cap

Applying Sealer to the Block

Remove or Disconnect:

1. Transmission, if equipped.
2. Damper and flywheel or flexplate, as equipped.

NOTICE: Care should be taken when removing the rear crankshaft oil seal so as not to nick the crankshaft sealing surface.

3. Crankshaft rear oil seal. Use care not to damage the crankshaft seal surface.

Inspect:

- Chamfer on crankshaft for grit, loose rust, and burrs. Correct as necessary.

Clean:

- Seal running surface on the crankshaft with a non-abrasive cleaner.

Install or Connect:

Tool required:

J-38841 Seal Installer

1. Crankshaft rear oil seal.
 - Lubricate the inner and outer diameter of the seal with engine oil.
 - Install the seal or J-38841.
 - Position J-38841 against the crankshaft. Thread the attaching screws into the tapped holes in the crankshaft.
 - Tighten the screws securely with a screwdriver. This will ensure that the seal is installed squarely over the crankshaft.
 - Turn the handle until it bottoms.
 - Remove J-38841.
2. Damper and flywheel or flexplate, as equipped.
3. Transmission, if equipped.

MEASURING CAMSHAFT LOBE LIFT

Tool required:

J-8520 Camshaft Lobe Lift Indicator

1. Remove the rocker arm, as outlined previously.
2. Position the dial indicator (part of J-8520) so the plunger rests on the pushrod end, as shown in next figure. Make sure the pushrod is in the filter socket.
3. Rotate the crankshaft slowly in the direction of rotation until the lifter is on the heel of the cam lobe. At this point, the pushrod will be in its lowest position.
4. Set the dial indicator on zero, then rotate the crankshaft slowly, or attach an auxiliary starter switch and "bump" the engine over, until the pushrod is in fully raised position.

IMPORTANT! Whenever the engine is cranked remotely at the starter, with a special jumper cable, or other means, the primary leads should be disconnected from the distributor or ignition coil.

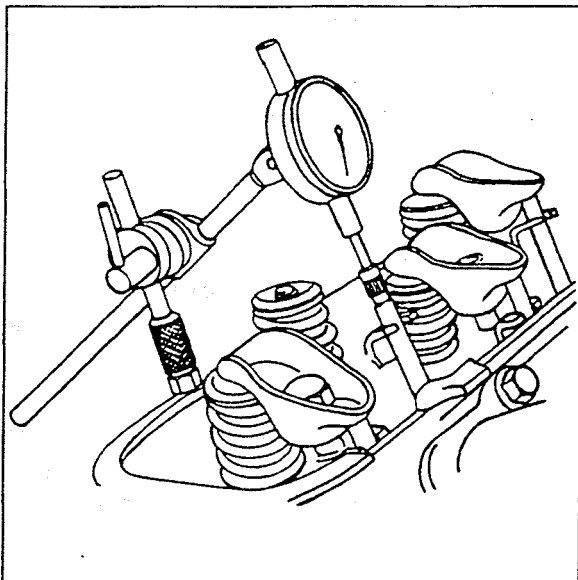
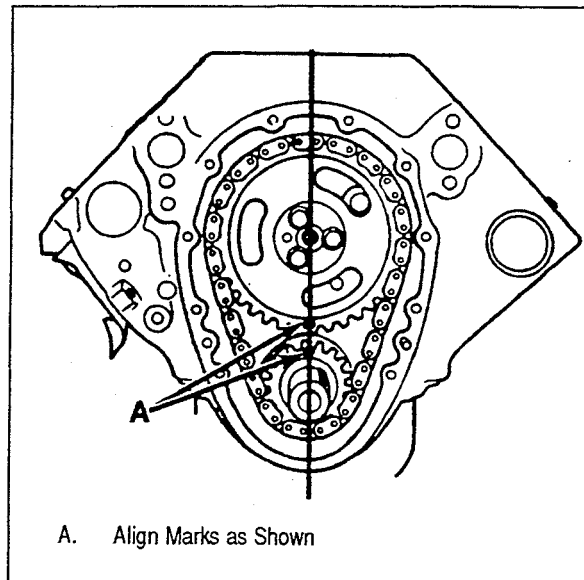
**Measuring Camshaft Lobe Lift**

A. Align Marks as Shown

Timing Marks

5. Compare the total lift recorded from the dial indicator with specifications.
6. If camshaft readings for all lobes are within specifications, remove dial indicator assembly.
7. Install the rocker arm, ball and bolt, as outlined previously.

CAMSHAFT REPLACEMENT

Remove or Disconnect:

Tool required:

J-28509-A Crankshaft Sprocket Puller

1. Battery negative cable.
2. Weather cover and flame arrestor.
3. Rocker arm covers, as outlined previously.
4. Coolant pump. (See "Cooling Systems" section in this manual.)
5. Torsional damper, as outlined previously.
6. Front cover, as outlined previously.
7. Distributor.
8. Intake manifold, as outlined previously.
9. Pushrods and hydraulic lifters, as outlined previously.
 - Align the timing marks as shown in figure above.
10. Camshaft sprocket bolts.

11. Camshaft sprocket and timing chain. The sprocket is a light interference fit on the camshaft. Tap the sprocket on its lower edge to loosen it.
12. Crankshaft sprocket (if required). Use J-28509-A.
13. Camshaft.
 - Install two or three 5/16-18 bolts to 100-125 mm (4-5 inches) long into the camshaft threaded holes. Use these bolts to handle the camshaft as shown in figure below.
 - Pull the camshaft from the block. Use care to prevent damage to the camshaft bearings.

Cleaning, Inspection and Repair:

- Clean, inspect and repair or replace the camshaft and related components.

Install or Connect:

Tool required:

J-22102 Crankshaft Sprocket Installer

- Coat the camshaft lobes and journals with high viscosity oil with zinc.
1. Two or three 5/16-18 bolts 100-125 mm (4-5 inches) long into the camshaft threaded holes. Use these bolts to handle the camshaft.
 2. Camshaft in the engine. Handle the camshaft carefully to prevent damage to the camshaft bearings.

CAMSHAFT REPLACEMENT (Continued)

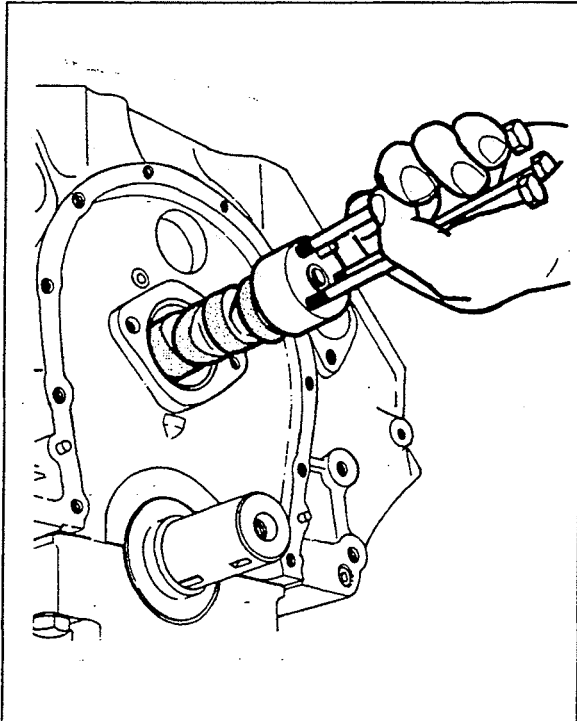

Replacing the Camshaft

3. Crankshaft sprocket (if removed). Use J-22102. Make sure the timing mark faces outside.
4. Camshaft sprocket and timing chain.

IMPORTANT! Line up the timing marks on the camshaft sprocket and crankshaft sprocket.

Tighten:

- Bolts to 27 N•m (20 ft.lbs.)

6. Hydraulic lifters and pushrods, and rocker arms, as outlined previously.

IMPORTANT! Replace all hydraulic lifters, crankcase oil and filter. Add high viscosity oil with zinc to the engine oil any time a new camshaft is installed.

7. Intake manifold, as outlined previously.
8. Distributor.

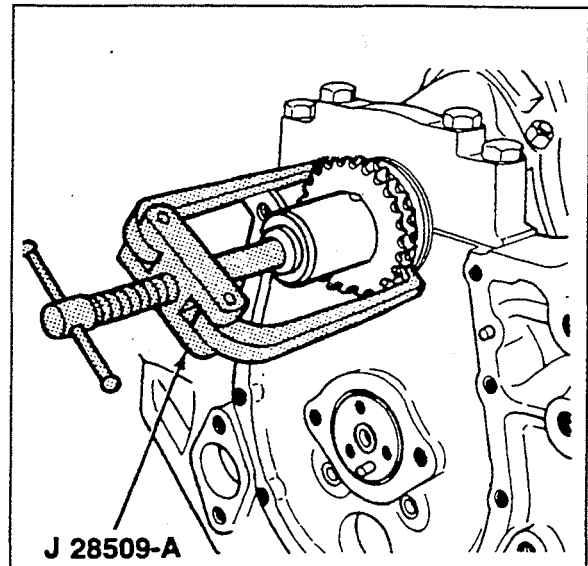

J 28509-A

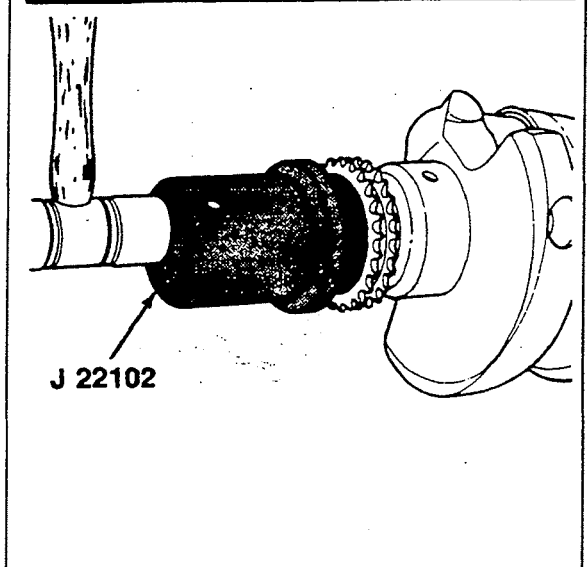

J 22102

Replacing the Crankshaft Sprocket

9. Front cover, as outlined previously.
10. Torsional damper, as outlined previously.
11. Coolant pump.
12. Rocker arm covers, as outlined previously.
13. Flame arrestor and weather cover.
14. Battery negative cable.
 - Fill the cooling system with the proper quantity and grade of coolant. (See "Cooling Systems" section in this manual.)

CONNECTING ROD AND PISTON REPLACEMENT

Tool required:
J-5239 Guide Set

1. Engine from boat.
2. Cylinder head, as outlined previously.
3. Oil pan, as outlined previously.
4. Oil pump, as outlined previously.
5. Ridge or deposits from the upper end of the cylinder bores.
 - Turn the crankshaft until the piston is at BDC.
 - Place a cloth on top of the piston.
 - Perform the cutting operation with a ridge reamer.
 - Turn the crankshaft until the piston is at TDC.
 - Remove the cloth and cuttings.
6. Connecting rod cap. Check the connecting rod and cap for identification marks. Mark the parts if required. The connecting rod and cap must be kept together as mating parts.
7. Connecting rod and piston.
 - Attach J-5239 to the connecting rod bolts.
 - Use the long guide rod of J-5239 to push the connecting rod and piston out of the bore.
8. Connecting rod bearing.

Cleaning, Inspection and Repair:

- Clean, inspect and repair or replace the components as necessary. Measure connecting rod bearing clearance, piston clearance, ring clearances, etc.

Install or Connect:

Tools required:
J-5239 Connecting Rod Guide Set
J-8037 Ring Compressor

- Make sure the cylinder walls are clean. Lubricate the cylinder wall lightly with engine oil.
- Make sure the piston is installed in the matching cylinder for which it was fitted.

Used pistons must be installed in the cylinder they were removed from.

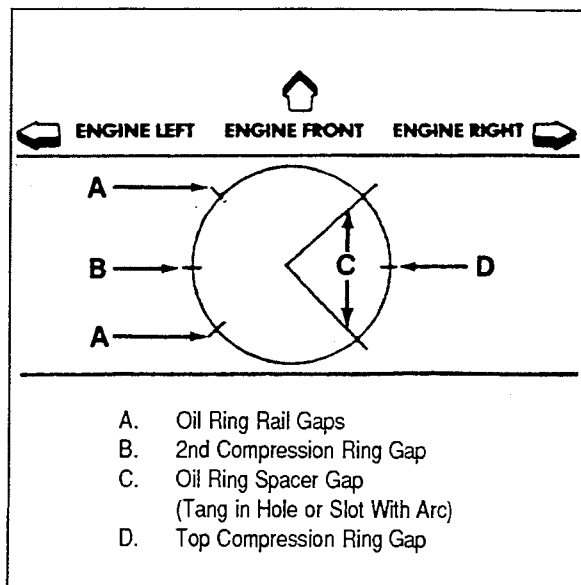

Ring End Gap Location

1. Connecting rod bearings.
 - Make sure the bearings are the proper size.
 - Install the bearings in the connecting rod and connecting rod cap.

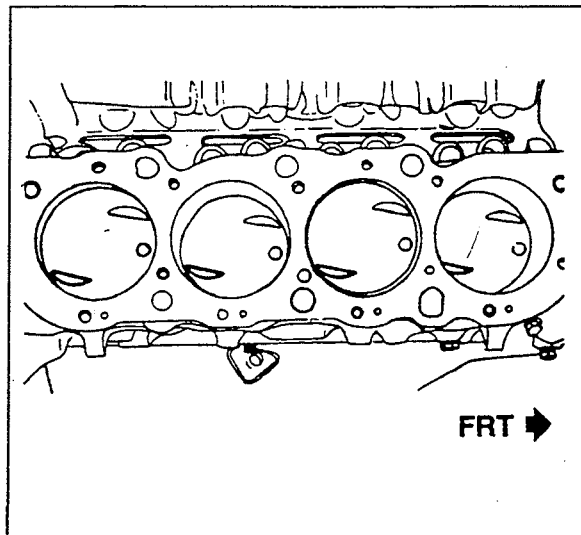

Piston Installed

- Lubricate the bearings with engine oil.
2. Piston and connecting rod to the proper bore.
 - With the connecting rod cap removed, install J-5239 onto the connecting rod studs.

CONNECTING ROD AND PISTON REPLACEMENT (Continued)

- Locate the piston ring end gaps. Lubricate the piston and rings with engine oil.

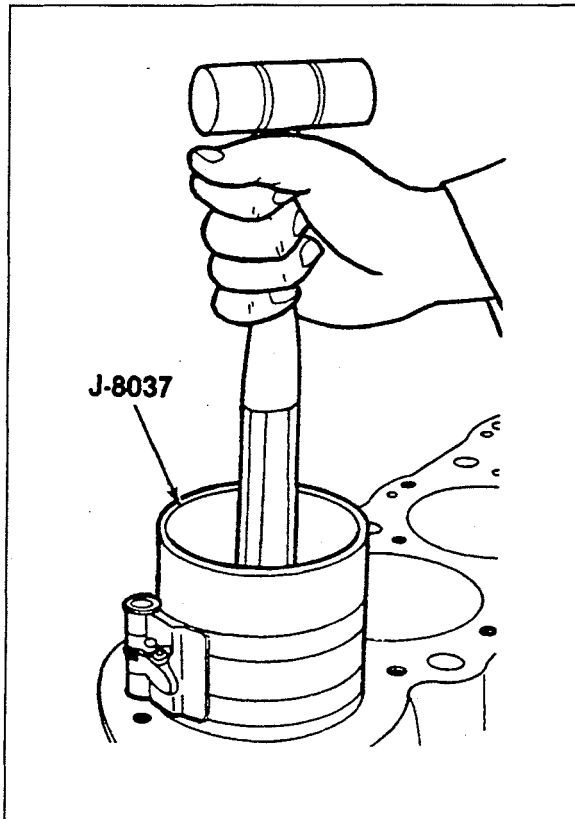

Installing the Piston

- Without disturbing the ring end gap location, install J-8037 over the piston.
- The piston must be installed so that the dimple faces the front of the engine.
- Place the piston in its matching bore. Using light blows with a hammer handle, tap the piston down into its bore. At the same time, from beneath the engine, guide the connecting rod to the crankpin with J-5239. Hold the ring compressor against the block until all rings have entered the cylinder bore.
- Remove J-5239 from the connecting rod bolts.

Measure:

- Connecting rod clearance.

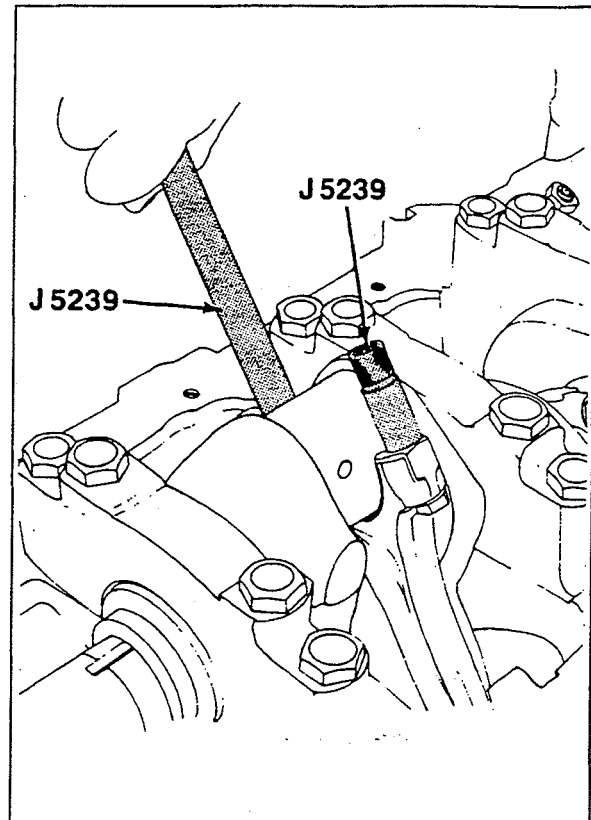

Replacing the Connecting Rod and Piston

3. Connecting rod cap and bearing.

IMPORTANT! Each connecting rod and bearing cap should be marked, beginning at the front of the engine. Cylinders 1, 3, 5 and 7 are the left bank and 2, 4, 6 and 8 are the right bank. The numbers on the connecting rod and bearing cap must be on the same side when installed in the cylinder bore. If a connecting rod is ever transposed from one block or cylinder to another, new connecting rod bearings should be fitted and the

NOTICE: See "Notice" on page 13-2.

4. Connecting rod cap nuts.

Tighten:

- Connecting rod cap nuts to 66 N•m (48 ft.lbs.)

CONNECTING ROD AND PISTON REPLACEMENT (Continued)

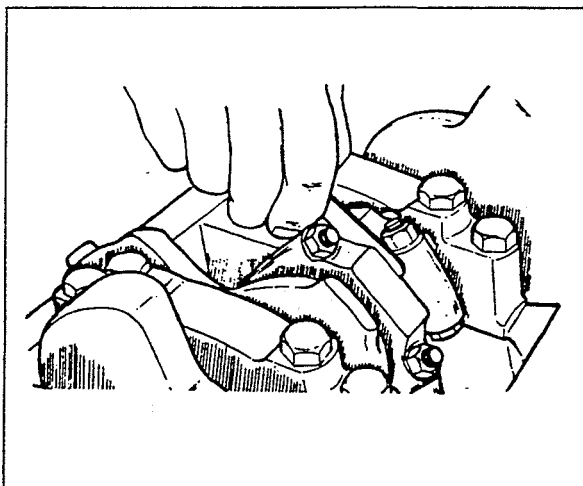

Measuring Connecting Rod Side Clearance

Measure:

- Connecting rod side clearance. Use a feeler gauge between the connecting rod and crankshaft. The correct clearance is 0.013-0.023 inch.
5. Oil pump (if removed), as outlined previously.
 6. Oil pan and cylinder head, as outlined previously.

MAIN BEARING REPLACEMENT

Remove or Disconnect:

Tools required:

J-8080 Main Bearing Remover/Installer

1. Spark plugs.
2. Oil pan, as outlined previously.
3. Oil pump, as outlined previously.
4. Main bearing caps.
 - Check the main bearing caps for location markings. Mark the caps if necessary. The caps must be returned to their original locations during assembly.
5. Lower main bearing inserts from the main bearing caps.

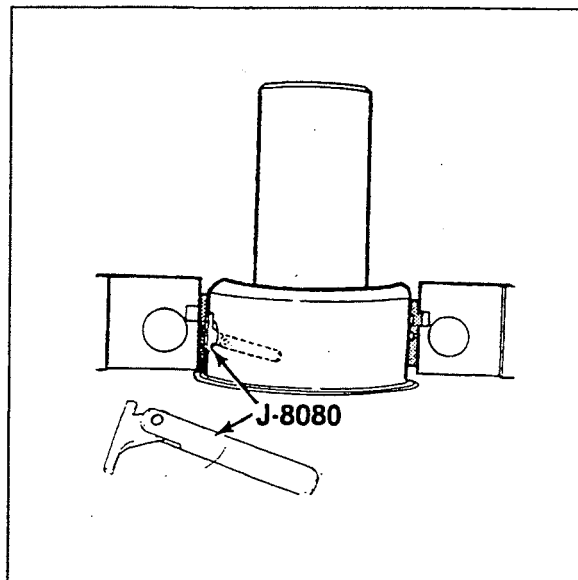

Removing the Main Bearing

6. Crankshaft rear oil seal, if necessary, as outlined previously.
7. Upper main bearing inserts.
 - Insert J-8080 into the crankshaft oil hole.
 - Rotate the crankshaft to "turn" the bearing insert out of the block.

Cleaning, Inspection and Repair:

- Clean, inspect and repair or replace the components as necessary.

Install or Connect:

NOTICE: For steps 3 and 4, see "Notice" on page 13-2.

Tool required:

J-8080 Main Bearing Remover/Installer

1. Upper main bearing inserts.
 - Insert tool J-8080 into a crankshaft main bearing oil hole.
 - Apply engine oil to inserts of the proper size.
 - Insert the plain end (without the bearing tang) of the insert between the crankshaft and the notched side of the block.
 - Rotate the crankshaft to "roll" the insert into the block.
 - Remove the tool.

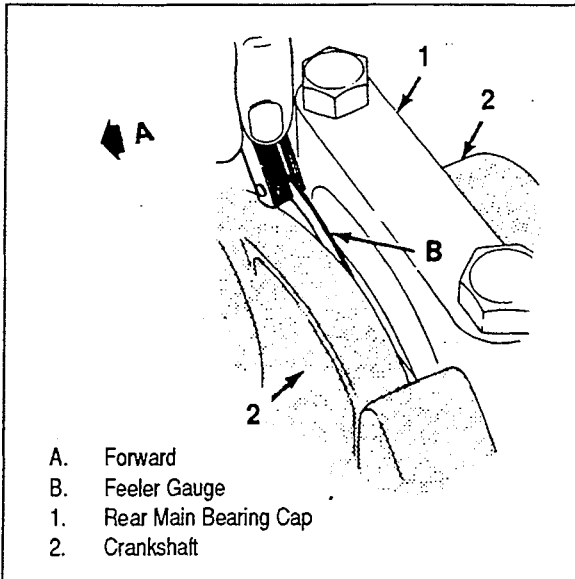
MAIN BEARING REPLACEMENT (Continued)**Measuring Crankshaft End Play**

2. Lower main bearing inserts to the main bearing caps.
 - Make sure the inserts are of the proper size.
 - Apply engine oil to the inserts.

Measure:

- Main bearing clearance.

3. Main bearing caps (except rear cap) and bolts to the block.

Tighten:

- Main bearing cap bolts to 135 N•m (100 ft.lbs.)

4. Rear main bearing cap.
 - Apply a brush-on type oil sealing compound to the mating surface of the block and cap. Do not allow any sealant on either crankshaft or rear oil seal.
 - Apply engine oil to the bearing insert.
 - Install the rear main bearing cap and bolts. Tighten the bolts temporarily to 14 N•m (10 ft.lbs.)

Measure:

- Crankshaft end play, as follows:
 - Tap the end of the crankshaft first

rearward then forward with a lead hammer. This will line up the rear main bearing and crankshaft thrust surfaces.

- Tighten the rear main bearing cap bolts to 135 N•m (100 ft.lbs.)
- With the crankshaft forced forward, measure at the front end of the rear main bearing with a feeler gauge. The proper clearance is 0.005-0.011 inch.

5. Oil pump, as outlined previously.
6. Oil pan, as outlined previously.
7. Spark plugs.

CRANKSHAFT REPLACEMENT

1. Remove the engine, as outlined later in this section.

Remove or Disconnect:

1. Oil pan, as outlined previously.
2. Oil pump (if necessary), as outlined previously.
3. Connecting rod caps. *NOTE: Check the connecting rod and cap for identification marks. Mark the parts if required. The connecting rod and cap must be kept together as mating parts.*
4. Main bearing caps. *NOTE: Check the main bearing caps for location markings. Mark the caps if necessary. The caps must be returned to their original locations during assembly.*
5. Remove crankshaft.

Install or Connect:

1. Upper main bearing inserts to the block.

IMPORTANT! If only undersized bearings are used, make sure they are fitted to the proper journals.

2. Crankshaft.
3. Lower main bearing inserts to the main bearing caps.

CRANKSHAFT REPLACEMENT (Continued)**Measure:**

- Main bearing clearance. (See "Mechanical Procedures" section in this manual.)
4. Main bearing caps (except rear cap) and bolt to the block.

Tighten:

- Main bearing cap bolts to 150 N•m (110 ft.lbs.)
5. Rear main bearing cap and bolts to the block.

Tighten:

- Rear main bearing cap bolts to 14 N•m (12 in.lbs.)

Measure:

- Crankshaft end play as follows:
 - Tap the end of the crankshaft first rearward then forward with a lead hammer. This lines up the rear main bearing and crankshaft thrust surfaces.

Tighten:

- Rear main bearing caps to 150 N•m (110 ft.lbs.)
- With crankshaft forced forward, measure at the front end of the rear main bearing with a feeler gauge. The proper clearance is 0.002-0.010 inch.

Inspect:

- Crankshaft for binding. Try turning the crankshaft to check for binding. If the crankshaft does not turn freely, loosen the main bearing cap bolts on one cap at a time until the tight bearing is located. Burrs on the bearing cap, foreign matter between the insert and the block or the bearing cap, or a faulty insert could cause a lack of clearance at the bearing.

FLYWHEEL REPLACEMENT**Remove or Disconnect:**

1. Transmission (if equipped), bellhousing and damper.

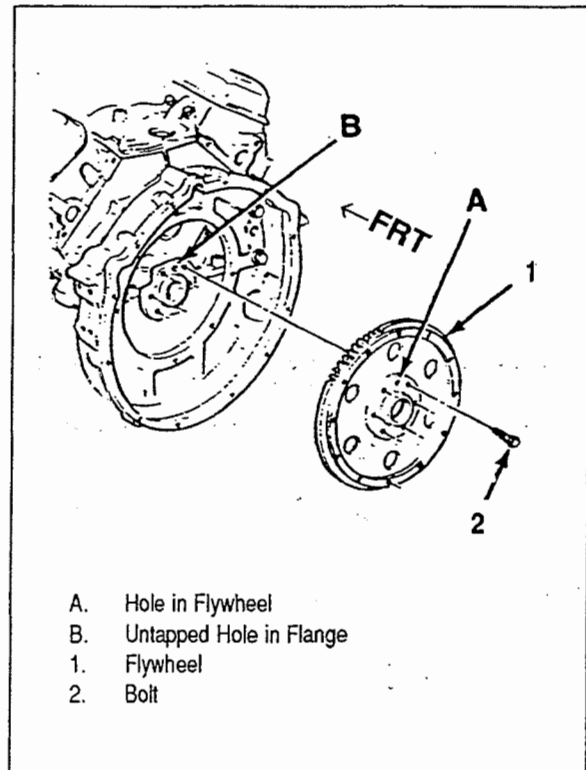
**Flywheel**

2. Flywheel bolts.
3. Flywheel.

Clean:

- Mating surfaces of crankshaft and flywheel. Remove any burrs.

Inspect:

- Flywheel for burning, scoring, warping and wear. Replace the flywheel if necessary. Do not machine the flywheel.
- Flywheel ring gear for worn or broken teeth.

FLYWHEEL RING GEAR REPLACEMENT

1. Use a torch to heat the gear around the entire circumference. Then drive the gear off the flywheel, using care not to damage the flywheel.
2. Uniformly heat the flywheel gear to a temperature which will expand the gear to permit installation. Temperature must not exceed 200°C (400°F).
3. As soon as the gear has been heated, install on the flywheel.

NOTICE: Never heat starter to red hot as this will change metal structure.

Install or Connect:

1. Flywheel.
2. Flywheel bolts.

NOTICE: See "Notice" on page 13-2.

Tighten:

- Flywheel bolts to 90 N•m (65 ft. lbs.)
3. Damper, bellhousing and transmission (if equipped).

ENGINE REPLACEMENT**Remove or Disconnect:**

1. Battery negative cable.
2. Throttle and shift linkages.
3. Necessary engine wiring.
 - Starter or solenoid wires
 - Alternator wires
 - Temperature sensor wire
 - Oil pressure sender wire
 - Distributor or coil wires
 - Any other necessary wiring
4. Fuel supply lines.
5. Power steering pump (if equipped).
6. Exhaust hoses at the manifolds.

7. Water inlet hose.
8. Coupling.
9. Front engine trunion mounts, from isolators and transmission mount from isolators or stringers.
10. Engine.

Install or Connect:

1. Engine in the boat.
 - A/igr coupling (Sportpac) or engine (Enpac).

NOTICE: See "Notice" on page 13-2.

2. Engine mounts.
3. Coupling.
4. Exhaust hoses at the manifolds.
5. Power steering pump connections (if used).
6. Fuel line.
7. Engine wiring
8. Battery negative cable.
 - Proper quantity and grade of coolant.

THREAD REPAIR

Damaged threads may be reconditioned by drilling out, retreading, and installing a suitable thread insert.

Tools required:

General purpose thread repair kits are available commercially.

CAUTION: Wear safety glasses to avoid eye damage.

1. Determine size, pitch and depth of damaged thread. If necessary, adjust stop collars on cutting tool and tap to required depth.
2. Drill out damaged thread. Clean out chips.
3. Tap hole. Lubricate tap with light engine oil. Clean the thread.
4. Thread the thread insert on the mandrel of the installer. Engage the tang of the insert onto the end of the mandrel.

THREAD REPAIR (Continued)

IMPORTANT! When correctly installed, the insert should be flush to one turn below the surface.

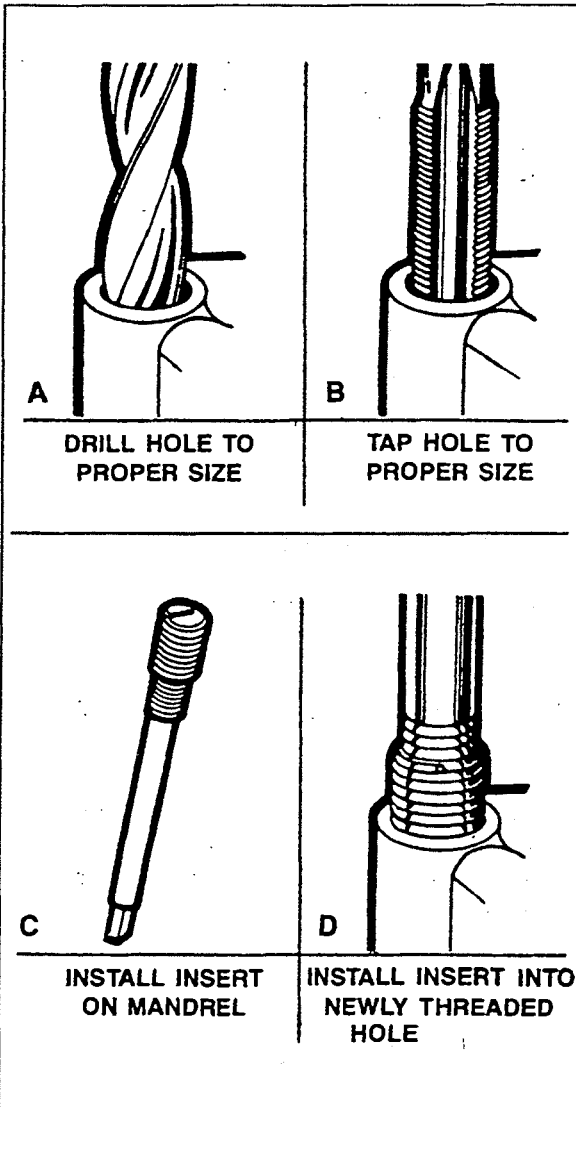

Repairing Thread Holes

IMPORTANT! Refer to the kit manufacturer's instructions regarding the size of drill and tap to be used.

5. Lubricate the insert with light engine oil (except when installing in aluminum) and install.
6. If the tang of the insert does not break off when backing out the installer, break the tang off with a drift.

ENGINE SPECIFICATIONS

All specifications are in INCHES unless otherwise noted.

GENERAL DATA:				
Type		V8		
Displacement		454 CID (7.4L)	502 CID (8.2L)	
Bore		4.25		
Stroke		4.00		
Compression Ratio		8.6:1	8.75:1	
Firing Order		1-8-4-3-6-5-7-2		
Oil Pressure (Minimum)		10 psi # 500 RPM Min.; 40-60 psi @ 2000 RPM		
CYLINDER BORE:				
Diameter		4.2500-4.2507	4.4700-4.4707	
Out of Round	Production	0.001 (Maximum)		
	Service	0.002 (Maximum)		
Taper	Production	Thrust Side	0.0005 (Maximum)	
		Relief Side	0.001 (Maximum)	
	Service	0.001 (Maximum)		
PISTON:				
Clearance	Production	0.0030-0.0042		
	Service Limit	0.005 (Maximum)		
PISTON RING:				
C O M P R E S S I O N	Groove Clearance	Production	Top	0.0012-0.0029
			2nd	0.0012-0.0029
		Service Limit	Hi-Limit Production +0.001	
	Gap	Production	Top	0.0010-0.018
			2nd	0.016-0.024
		Service Limit	Hi-Limit Production +0.010	
O I L	Groove Clearance	Production	0.0050-0.0065	
		Service Limit	Hi-Limit Production +0.001	
	Gap	Production	0.010-0.030	
		Service Limit	Hi-Limit Production +0.010	

ENGINE SPECIFICATIONS

All specifications are in INCHES unless otherwise noted.

PISTON PIN:			454 CID (7.4L)	502 CID (8.2L)
Diameter			0.98945-0.98965	
Clearance In Piston	Production		0.0002-0.0007	
	Service Limit		0.001 (Maximum)	
Fit In Rod			0.0031-0.0021 Interference	
CRANKSHAFT:				
Main Journal	Diameter	#1, #2, #3, #4, #5	2.7482-2.7489	
	Taper	Production	0.0004 (Maximum)	
		Service Limit	0.001 (Maximum)	
	Out Of Round	Production	0.0004 (Maximum)	
		Service Limit	0.001 (Maximum)	
	Main Bearing Clearance	Production	#1, #2, #3, #4	0.0017-0.0030
#5			0.0025-0.0038	
Service Limit		#1, #2, #3, #4	0.0010-0.0030	
		#5	0.0025-0.0040	
Crankshaft End Play			0.005-0.011	
Crankpin	Diameter	2.1990-2.1996		
	Taper	Production	0.0005	
		Service Limit	0.001	
	Out of Round	Production	0.0005	
		Service Limit	0.001	
	Rod Bearing Clearance	Production	0.0011-0.0029	
Service Limit		0.003 (Maximum)		
Rod Side Clearance			0.0013-0.023	
CAMSHAFT:				
Lobe Lift \pm 0.002	Intake	0.2343		
	Exhaust	0.2530		
Journal Diameter			1.9482-1.9492	
VALVE SYSTEM:				
Lifter			Hydraulic	
Rocker Arm Ratio			1.70:1	

ENGINE SPECIFICATIONS









All specifications are in INCHES unless otherwise noted.

VALVE SYSTEM (CONTINUED):			454 CID (7.4L)	502 CID (8.2L)
Valve Lash	Intake		One Turn Down From Zero Lash	
	Exhaust			
Face Angle (Intake & Exhaust)			45°	
Seat Angle (Intake & Exhaust)			46°	
Seat Runout (Intake & Exhaust)			0.002 (Maximum)	
Seat Width	Intake		1/32-1/16	
	Exhaust		1/16-3/32	
Stem Clearance	Production	Intake	0.0010-0.0027	
		Exhaust	0.0012-0.0029	
	Service	Intake	Hi-Limit Production +0.001	
		Exhaust	Hi-Limit Production +0.002	
Valve Spring	Free Length		2.12	
	Pressure lbs. @ in.	Closed	74-86 lbs. @ 1.80 in.	
		Open	195-215 lbs. @ 1.40 in.	
	Installed Height \pm 1/32"			1 51/64 (1.80 in.)
Valve Spring Fit In Damper			0.042-0.094 Interference	

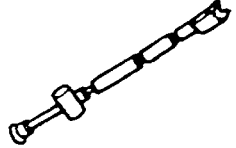
TORQUE SPECIFICATIONS FOR FASTENER TIGHTENING

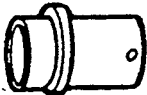
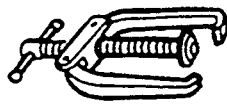
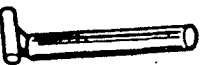
Item	N·m	Ft.Lbs.	In.Lbs.
Rocker Arm Cover Bolts	7		70
Rocker Arm Bolts	54	40	
Intake Manifold Bolts	54	40	
Exhaust Manifold Bolts	54	40	
Cylinder Head Bolts	110	80	
Torsional Damper Bolts	115	85	
Front Cover to Block Bolts	10		96
Oil Pan to Block Bolts	18		160
Oil Pump Bolt	90	65	
Main Bearing Caps	135	100	
Camshaft Sprocket bolts	26	20	
Connecting Rod Cap Nuts	66	48	
Flywheel Bolts	90	65	
Oil Pump Cover Bolts	9		80
Flywheel Housing Bolts	40	30	
Coolant Pump Bolts	40	30	
Coolant Outlet Bolts	40	30	
Spark Plugs	30	22	
Oil Pan Drain Plug	28	20	
Block Drain Plug	12		112

SPECIAL TOOLS

1.		J 23523-E	7.		J 5239
2.		J 5892-C	8.		J 9290-01
3.		J 23590	9.		J 3049-A
4.		J 22102	10.		J 28509-A
5.		J 8080	11.		J 8520
6.		J 8037	12.		J 38841

1. Torsional Damper Remover And Installer
2. Valve Spring Compressor
3. Air Adapter
4. Crankshaft Seal Installer And Centering Tool
5. Main Bearing Replacer
6. Piston Ring Compressor
7. Guide Set
8. Hydraulic Lifter Remover (Slide Hammer Type)
9. Hydraulic Lifter Remover (Plier Type)
10. Crankshaft Sprocket Puller
11. Dial Indicator Adapter
12. Crankshaft Rear Seal Installer