

Engine Mechanical - 4.8L, 5.3L, and 6.0L

Specifications

SIE-ID = 890258 LMD = 07-jun-2002

Fastener Tightening Specifications

Application	Specification	
	Metric	English
Air Cleaner Outlet Duct Clamp	7 N·m	62 lb in
Air Conditioning Belt Tensioner Bolt	50 N·m	37 lb ft
Battery Cable Channel Bolt	12 N·m	106 lb in
Camshaft Retainer Bolts	25 N·m	18 lb ft
Camshaft Sensor Bolt	25 N·m	18 lb ft
Camshaft Sprocket Bolts	35 N·m	26 lb ft
Connecting Rod Bolts – First Pass	20 N·m	15 lb ft
Connecting Rod Bolts – Final Pass	75 degrees	
Coolant Temperature Gage Sensor	20 N·m	15 lb ft
Crankshaft Balancer Bolt – Installation Pass – to Ensure the Balancer is Completely Installed	330 N·m	240 lb ft
Crankshaft Balancer Bolt – First Pass – Install a NEW Bolt After the Installation Pass and Tighten as Described in the First and Final Passes	50 N·m	37 lb ft
Crankshaft Balancer Bolt – Final Pass	140 degrees	
Crankshaft Bearing Cap Bolts – Inner Bolts – First Pass in Sequence	20 N·m	15 lb ft
Crankshaft Bearing Cap Bolts – Inner Bolts – Final Pass in Sequence	80 degrees	
Crankshaft Bearing Cap Bolts – Outer Bolts – First Pass in Sequence	20 N·m	15 lb ft
Crankshaft Bearing Cap Bolts – Outer Bolts – Final Pass in Sequence	51 degrees	
Crankshaft Bearing Cap Side Bolts	25 N·m	18 lb ft
Crankshaft Oil Deflector Nuts	25 N·m	18 lb ft
Crankshaft Position Sensor Bolt	25 N·m	18 lb ft
Crossbar Bolt	100 N·m	74 lb ft
Cylinder Head Bolts – First Pass all M11 Bolts in Sequence	30 N·m	22 lb ft
Cylinder Head Bolts – Second Pass all M11 Bolts in Sequence	90 degrees	
Cylinder Head Bolts – Final Pass all M11 Bolts in Sequence – Excluding the Medium Length Bolts at the Front and Rear of Each Cylinder Head	90 degrees	
Cylinder Head Bolts – Final Pass M11 Medium Length Bolts at the Front and Rear of Each Cylinder Head in Sequence	50 degrees	
Cylinder Head Bolts – M8 Inner Bolts in Sequence	30 N·m	22 lb ft
Cylinder Head Coolant Plug	20 N·m	15 lb ft
Differential Carrier Lower Mounting Bolt/Nut	100 N·m	74 lb ft
Drive Belt Idler Pulley Bolt	50 N·m	37 lb ft
Drive Belt Tensioner Bolt	50 N·m	37 lb ft
Engine Block Coolant Drain Plugs	60 N·m	44 lb ft
Engine Block Heater	40 N·m	30 lb ft
Engine Block Oil Gallery Plugs	60 N·m	44 lb ft
Engine Coolant Air Bleed Pipe and Cover Bolts	12 N·m	106 lb in
Engine Flywheel Bolts – First Pass	20 N·m	15 lb ft
Engine Flywheel Bolts – Second Pass	50 N·m	37 lb ft
Engine Flywheel Bolts – Final Pass	100 N·m	74 lb ft
Engine Front Cover Bolts	25 N·m	18 lb ft
Engine Harness Ground Bolt – Right Rear	16 N·m	12 lb ft

Fastener Tightening Specifications (cont'd)

Application	Specification	
	Metric	English
Engine Harness Ground Bolt to Block	25 N·m	18 lb ft
Engine Rear Cover Bolts	25 N·m	18 lb ft
Engine Service Lift Bracket M10 Bolts	50 N·m	37 lb ft
Engine Service Lift Bracket M8 Bolt	25 N·m	18 lb ft
Engine Shield Bolt	20 N·m	15 lb ft
Engine Valley Cover Bolts	25 N·m	18 lb ft
Engine Wiring Harness Bracket Nut	5 N·m	44 lb in
Evaporative Emission (EVAP) Purge Solenoid Bolt	10 N·m	89 lb in
Exhaust Manifold Bolts – First Pass	15 N·m	11 lb ft
Exhaust Manifold Bolts – Final Pass	25 N·m	18 lb ft
Exhaust Manifold Heat Shield Bolts	9 N·m	80 lb in
Fuel Rail Bolts	10 N·m	89 lb in
Fuel Rail Cover Bolt	9 N·m	80 lb in
Fuel Rail Crossover Tube Bolts	3.8 N·m	34 lb in
Fuel Rail Stop Bracket Bolt	50 N·m	37 lb ft
Generator Bracket Bolt	50 N·m	37 lb ft
Generator Cable Nut	9 N·m	80 lb in
Heater Hose Bracket Nut	9 N·m	80 lb in
Hood Hinge Bolt	25 N·m	18 lb ft
Ignition Coil-to-Bracket Bolts	8 N·m	71 lb in
Ignition Coil Bracket-to-Valve Rocker Arm Cover Bolts	12 N·m	106 lb in
Inner Axle Housing Nut	100 N·m	74 lb ft
Intake Manifold Bolts – First Pass in Sequence	5 N·m	44 lb in
Intake Manifold Bolts – Final Pass in Sequence	10 N·m	89 lb in
Intake Manifold Sight Shield Bolts	10 N·m	89 lb in
Intake Manifold Sight Shield Bracket Bolts	5 N·m	45 lb in
Intake Manifold Sight Shield Retainer Bolt	5 N·m	44 lb in
Intake Manifold Wiring Harness Stud	10 N·m	89 lb in
Knock Sensors	20 N·m	15 lb ft
Oil Filter	30 N·m	22 lb ft
Oil Filter Fitting	55 N·m	40 lb ft
Oil Level Indicator Tube Bolt	25 N·m	18 lb ft
Oil Level Sensor	13 N·m	115 lb in
Oil Pan Baffle Bolts	12 N·m	106 lb in
Oil Pan Closeout Cover Bolt – Left Side	9 N·m	80 lb in
Oil Pan Closeout Cover Bolt – Right Side	9 N·m	80 lb in
Oil Pan Cover Bolts	12 N·m	106 lb in
Oil Pan Drain Plug	25 N·m	18 lb ft
Oil Pan M8 Bolts – Oil Pan-to-Engine Block and Oil Pan-to-Front Cover	25 N·m	18 lb ft
Oil Pan M6 Bolts – Oil Pan-to-Rear Cover	12 N·m	106 lb in
Oil Pan Skid Plate Bolt	20 N·m	15 lb ft
Oil Pressure Sensor	20 N·m	15 lb ft
Oil Pump-to-Engine Block Bolts	25 N·m	18 lb ft
Oil Pump Cover Bolts	12 N·m	106 lb in
Oil Pump Relief Valve Plug	12 N·m	106 lb in
Oil Pump Screen Nuts	25 N·m	18 lb ft
Oil Pump Screen-to-Oil Pump Bolt	12 N·m	106 lb in

Fastener Tightening Specifications (cont'd)

Application	Specification	
	Metric	English
Positive Battery Cable Clip Bolt	9 N·m	80 lb in
Power Steering Pump Rear Bolt	50 N·m	37 lb ft
Spark Plugs – New Cylinder Heads	20 N·m	15 lb ft
Spark Plugs – All Subsequent Installations	15 N·m	11 lb ft
Throttle Body Nuts	10 N·m	89 lb in
Throttle Body Studs	6 N·m	53 lb in
Torque Converter Bolt – 4L60-E/4L65-E	63 N·m	47 lb ft
Torque Converter Bolt – 4L80-E/4L85-E	60 N·m	44 lb ft
Transmission Bolt/Stud	50 N·m	37 lb ft
Transmission Cover Bolt	12 N·m	106 lb in
Transmission Oil Level Indicator Tube Nut	18 N·m	13 lb ft
Valve Lifter Guide Bolts	12 N·m	106 lb in
Valve Rocker Arm Bolts	30 N·m	22 lb ft
Valve Rocker Arm Cover Bolts	12 N·m	106 lb in
Water Inlet Housing Bolts	15 N·m	11 lb ft
Water Pump Bolts – First Pass	15 N·m	11 lb ft
Water Pump Bolts – Final Pass	30 N·m	22 lb ft
Water Pump Cover Bolts	15 N·m	11 lb ft

SIE-ID = 823792 LMD = 03-jun-2002

Engine Mechanical Specifications (LR4 VIN V)

Application	Specification	
	Metric	English
General		
Engine Type	V 8	
Displacement	4.8L	293 CID
RPO	LR4	
VIN	V	
Bore	96.0–96.018 mm	3.779–3.78 in
Stroke	83.0 mm	3.268 in
Compression Ratio	9.47:1	
Firing Order	1–8–7–2–6–5–4–3	
Spark Plug Gap	1.524 mm	0.06 in
Block		
Camshaft Bearing Bore Diameter	55.063–55.088 mm	2.168–2.169 in
Crankshaft Main Bearing Bore Diameter	69.871–69.889 mm	2.75–2.751 in
Crankshaft Main Bearing Bore Out-of-Round	0.006 mm	0.0002 in
Cylinder Bore Diameter	96.0–96.018 mm	3.779–3.78 in
Cylinder Bore Taper – Thrust Side	0.018 mm	0.0007 in
Cylinder Head Deck Height – Measuring from the Centerline of Crankshaft to the Deck Face	234.57–234.82 mm	9.235–9.245 in
Cylinder Head Deck Surface Flatness – Measured Within a 152.4 mm (6.0 in) Area	0.11 mm	0.004 in
Cylinder Head Deck Surface Flatness – Measuring the Overall Length of the Block Deck	0.22 mm	0.008 in
Valve Lifter Bore Diameter	21.417–21.443 mm	0.843–0.844 in
Camshaft		
Camshaft End Play	0.025–0.305 mm	0.001–0.012 in

Engine Mechanical Specifications (LR4 VIN V) (cont'd)

Application	Specification	
	Metric	English
Camshaft Journal Diameter	54.99–55.04 mm	2.164–2.166 in
Camshaft Journal Out-of-Round	0.025 mm	0.001 in
Camshaft Lobe Lift – Exhaust	6.96 mm	0.274 in
Camshaft Lobe Lift – Intake	6.82 mm	0.268 in
Camshaft Runout – Measured at the Intermediate Journals	0.05 mm	0.002 in
Connecting Rod		
Connecting Rod Bearing Clearance – Production	0.023–0.065 mm	0.0009–0.0025 in
Connecting Rod Bearing Clearance – Service	0.023–0.076 mm	0.0009–0.003 in
Connecting Rod Bore Diameter – Bearing End	56.505–56.525 mm	2.224–2.225 in
Connecting Rod Bore Out-of-Round – Bearing End – Production	0.004–0.008 mm	0.00015–0.0003 in
Connecting Rod Bore Out-of-Round – Bearing End – Service	0.004–0.008 mm	0.00015–0.0003 in
Connecting Rod Side Clearance	0.11–0.51 mm	0.00433–0.02 in
Crankshaft		
Connecting Rod Journal Diameter – Production	53.318–53.338 mm	2.0991–2.0999 in
Connecting Rod Journal Diameter – Service	53.308 mm	2.0987 in
Connecting Rod Journal Out-of-Round – Production	0.005 mm	0.0002 in
Connecting Rod Journal Out-of-Round – Service	0.01 mm	0.0004 in
Connecting Rod Journal Taper – Maximum for 1/2 of Journal Length – Production	0.005 mm	0.0002 in
Connecting Rod Journal Taper – Maximum for 1/2 of Journal Length – Service	0.02 mm	0.00078 in
Crankshaft End Play	0.04–0.2 mm	0.0015–0.0078 in
Crankshaft Main Bearing Clearance – Production	0.02–0.052 mm	0.0008–0.0021 in
Crankshaft Main Bearing Clearance – Service	0.02–0.065 mm	0.0008–0.0025 in
Crankshaft Main Journal Diameter – Production	64.993–65.007 mm	2.558–2.559 in
Crankshaft Main Journal Diameter – Service	64.993 mm	2.558 in
Crankshaft Main Journal Out-of-Round – Production	0.003 mm	0.000118 in
Crankshaft Main Journal Out-of-Round – Service	0.008 mm	0.0003 in
Crankshaft Main Journal Taper – Production	0.01 mm	0.0004 in
Crankshaft Main Journal Taper – Service	0.02 mm	0.00078 in
Crankshaft Rear Flange Runout	0.05 mm	0.002 in
Crankshaft Reluctor Ring Runout – Measured 1.0 mm (0.04 in) Below Tooth Diameter	0.7 mm	0.028 in
Crankshaft Thrust Surface – Production	26.14–26.22 mm	1.029–1.0315 in
Crankshaft Thrust Surface – Service	26.22 mm	1.0315 in
Crankshaft Thrust Surface Runout	0.025 mm	0.001 in
Cylinder Head		
Cylinder Head Height/Thickness – Measured from the Cylinder Head Deck to the Valve Rocker Arm Cover Seal Surface	120.2 mm	4.732 in
Surface Flatness – Block Deck – Measured Within a 152.4 mm (6.0 in) Area	0.08 mm	0.003 in
Surface Flatness – Block Deck – Measuring the Overall Length of the Cylinder Head	0.1 mm	0.004 in
Surface Flatness – Exhaust Manifold Deck	0.13 mm	0.005 in
Surface Flatness – Intake Manifold Deck	0.08 mm	0.0031 in
Valve Guide Installed Height – Measured from the Spring Seat Surface to the Top of the Guide	17.32 mm	0.682 in
Intake Manifold		

Engine Mechanical Specifications (LR4 VIN V) (cont'd)

Application	Specification	
	Metric	English
Surface Flatness – Measured at Gasket Sealing Surfaces and Measured Within a 200 mm (7.87 in) Area that Includes Two Runner Port Openings	0.3 mm	0.118 in
Lubrication System		
Oil Capacity – with Filter	5.68 Liters	6.0 Quarts
Oil Capacity – without Filter	4.73 Liters	5.0 Quarts
Oil Pressure – Minimum – Hot	41 kPa at 1,000 engine RPM 124 kPa at 2,000 engine RPM 165 kPa at 4,000 engine RPM	6 psig at 1,000 engine RPM 18 psig at 2,000 engine RPM 24 psig at 4,000 engine RPM
Oil Pan		
Front Cover Alignment – at Oil Pan Surface	0.0–0.5 mm	0.0–0.02 in
Rear Cover Alignment – at Oil Pan Surface	0.0–0.5 mm	0.0–0.02 in
Oil Pan Alignment – to Rear of Engine Block at Transmission Bell Housing Mounting Surface	0.0–0.25 mm	0.0–0.01 in
Piston Rings		
Piston Ring End Gap – First Compression Ring – Measured in Cylinder Bore – Production	0.23–0.44 mm	0.009–0.017 in
Piston Ring End Gap – First Compression Ring – Measured in Cylinder Bore – Service	0.23–0.5 mm	0.009–0.0196 in
Piston Ring End Gap – Second Compression Ring – Measured in Cylinder Bore – Production	0.44–0.7 mm	0.017–0.027 in
Piston Ring End Gap – Second Compression Ring – Measured in Cylinder Bore – Service	0.44–0.76 mm	0.0173–0.03 in
Piston Ring End Gap – Oil Control Ring – Measured in Cylinder Bore – Production	0.18–0.75 mm	0.007–0.029 in
Piston Ring End Gap – Oil Control Ring – Measured in Cylinder Bore – Service	0.18–0.81 mm	0.007–0.032 in
Piston Ring to Groove Clearance – First Compression Ring – Production	0.04–0.085 mm	0.00157–0.00335 in
Piston Ring to Groove Clearance – First Compression Ring – Service	0.04–0.085 mm	0.00157–0.00335 in
Piston Ring to Groove Clearance – Second Compression Ring – Production	0.04–0.078 mm	0.00157–0.0031 in
Piston Ring to Groove Clearance – Second Compression Ring – Service	0.04–0.078 mm	0.00157–0.0031 in
Piston Ring to Groove Clearance – Oil Control Ring – Production	0.012–0.2 mm	0.0005–0.0078 in
Piston Ring to Groove Clearance – Oil Control Ring – Service	0.012–0.2 mm	0.0005–0.0078 in
Pistons and Pins		
Piston – Piston Diameter – Measured Over Skirt Coating	96.002–96.036 mm	3.779–3.78 in
Piston – Piston to Bore Clearance – Production	–0.036 to 0.016 mm	–0.0014 to 0.0006 in
Piston – Piston to Bore Clearance – Service Limit with Skirt Coating Worn Off	0.071 mm	0.0028 in
Pin – Piston Pin Fit in Connecting Rod Bore	0.02–0.043 mm – interference	0.00078–0.00169 in – interference
Pin – Piston Pin Clearance to Piston Pin Bore – Production	0.007–0.02 mm	0.00027–0.00078 in
Pin – Piston Pin Clearance to Piston Pin Bore – Service	0.007–0.021 mm	0.00027–0.00082 in
Pin – Piston Pin Diameter	23.997–24.0 mm	0.9447–0.9448 in
Valve System		
Valves – Valve Face Angle	45 degrees	
Valves – Valve Face Width	1.25 mm	0.05 in

Engine Mechanical Specifications (LR4 VIN V) (cont'd)

Application	Specification	
	Metric	English
Valves – Valve Lash	Net Lash – No Adjustment	
Valves – Valve Lift – Intake	11.6 mm	0.457 in
Valves – Valve Lift – Exhaust	11.85 mm	0.466 in
Valves – Valve Seat Angle	46 degrees	
Valves – Valve Seat Runout	0.05 mm	0.002 in
Valves – Valve Seat Width – Exhaust	1.78 mm	0.07 in
Valves – Seat Width – Intake	1.02 mm	0.04 in
Valves – Valve Stem Diameter – Production	7.955–7.976 mm	0.313–0.314 in
Valves – Valve Stem Diameter – Service	7.95 mm	0.313 in
Valves – Stem-to-Guide Clearance – Production – Intake	0.025–0.066 mm	0.001–0.0026 in
Valves – Stem-to-Guide Clearance – Service – Intake	0.093 mm	0.0037 in
Valves – Stem-to-Guide Clearance – Production – Exhaust	0.025–0.066 mm	0.001–0.0026 in
Valves – Stem-to-Guide Clearance – Service – Exhaust	0.093 mm	0.0037 in
Rocker Arms – Valve Rocker Arm Ratio	1.70:1	
Valve Springs – Valve Spring Free Length	52.9 mm	2.08 in
Valve Springs – Installed Height	45.75 mm	1.8 in
Valve Springs – Valve Spring Load – Closed	340 N at 45.75 mm	76 lb at 1.8 in
Valve Springs – Valve Spring Load – Open	980 N at 33.55 mm	220 lb at 1.32 in

SIE-ID = 823794 LMD = 03-jun-2002

Engine Mechanical Specifications (LM7 VIN T)

Application	Specification	
	Metric	English
General		
Engine Type	V 8	
Displacement	5.3L	325 CID
RPO	LM7	
VIN	T	
Bore	96.0–96.018 mm	3.779–3.78 in
Stroke	92.0 mm	3.622 in
Compression Ratio	9.49:1	
Firing Order	1–8–7–2–6–5–4–3	
Spark Plug Gap	1.524 mm	0.06 in
Block		
Camshaft Bearing Bore Diameter	55.063–55.088 mm	2.168–2.169 in
Crankshaft Main Bearing Bore Diameter	69.871–69.889 mm	2.75–2.751 in
Crankshaft Main Bearing Bore Out-of-Round	0.006 mm	0.0002 in
Cylinder Bore Diameter	96.0–96.018 mm	3.779–3.78 in
Cylinder Bore Taper – Thrust Side	0.018 mm	0.0007 in
Cylinder Head Deck Height – Measuring from the Centerline of Crankshaft to the Deck Face	234.57–234.82 mm	9.235–9.245 in
Cylinder Head Deck Surface Flatness – Measured Within a 152.4 mm (6.0 in) Area	0.11 mm	0.004 in
Cylinder Head Deck Surface Flatness – Measuring the Overall Length of the Block Deck	0.22 mm	0.008 in
Valve Lifter Bore Diameter	21.417–21.443 mm	0.843–0.844 in
Camshaft		
Camshaft End Play	0.025–0.305 mm	0.001–0.012 in

Engine Mechanical Specifications (LM7 VIN T) (cont'd)

Application	Specification	
	Metric	English
Camshaft Journal Diameter	54.99–55.04 mm	2.164–2.166 in
Camshaft Journal Out-of-Round	0.025 mm	0.001 in
Camshaft Lobe Lift – Exhaust	6.96 mm	0.274 in
Camshaft Lobe Lift – Intake	6.82 mm	0.268 in
Camshaft Runout – Measured at the Intermediate Journals	0.05 mm	0.002 in
Connecting Rod		
Connecting Rod Bearing Clearance – Production	0.023–0.065 mm	0.0009–0.0025 in
Connecting Rod Bearing Clearance – Service	0.023–0.076 mm	0.0009–0.003 in
Connecting Rod Bore Diameter – Bearing End	56.505–56.525 mm	2.224–2.225 in
Connecting Rod Bore Out-of-Round – Bearing End – Production	0.004–0.008 mm	0.00015–0.0003 in
Connecting Rod Bore Out-of-Round – Bearing End – Service	0.004–0.008 mm	0.00015–0.0003 in
Connecting Rod Side Clearance	0.11–0.51 mm	0.00433–0.02 in
Crankshaft		
Connecting Rod Journal Diameter – Production	53.318–53.338 mm	2.0991–2.0999 in
Connecting Rod Journal Diameter – Service	53.308 mm	2.0987 in
Connecting Rod Journal Out-of-Round – Production	0.005 mm	0.0002 in
Connecting Rod Journal Out-of-Round – Service	0.01 mm	0.0004 in
Connecting Rod Journal Taper – Maximum for 1/2 of Journal Length – Production	0.005 mm	0.0002 in
Connecting Rod Journal Taper – Maximum for 1/2 of Journal Length – Service	0.02 mm	0.00078 in
Crankshaft End Play	0.04–0.2 mm	0.0015–0.0078 in
Crankshaft Main Bearing Clearance – Production	0.02–0.052 mm	0.0008–0.0021 in
Crankshaft Main Bearing Clearance – Service	0.02–0.065 mm	0.0008–0.0025 in
Crankshaft Main Journal Diameter – Production	64.993–65.007 mm	2.558–2.559 in
Crankshaft Main Journal Diameter – Service	64.993 mm	2.558 in
Crankshaft Main Journal Out-of-Round – Production	0.003 mm	0.000118 in
Crankshaft Main Journal Out-of-Round – Service	0.008 mm	0.0003 in
Crankshaft Main Journal Taper – Production	0.01 mm	0.0004 in
Crankshaft Main Journal Taper – Service	0.02 mm	0.00078 in
Crankshaft Rear Flange Runout	0.05 mm	0.002 in
Crankshaft Reluctor Ring Runout – Measured 1.0 mm (0.04 in) Below Tooth Diameter	0.7 mm	0.028 in
Crankshaft Thrust Surface – Production	26.14–26.22 mm	1.029–1.0315 in
Crankshaft Thrust Surface – Service	26.22 mm	1.0315 in
Crankshaft Thrust Surface Runout	0.025 mm	0.001 in
Cylinder Head		
Cylinder Head Height/Thickness – Measured from the Cylinder Head Deck to the Valve Rocker Arm Cover Seal Surface	120.2 mm	4.732 in
Surface Flatness – Block Deck – Measured Within a 152.4 mm (6.0 in) Area	0.08 mm	0.003 in
Surface Flatness – Block Deck – Measuring the Overall Length of the Cylinder Head	0.1 mm	0.004 in
Surface Flatness – Exhaust Manifold Deck	0.13 mm	0.005 in
Surface Flatness – Intake Manifold Deck	0.08 mm	0.0031 in
Valve Guide Installed Height – Measured from the Spring Seat Surface to the Top of the Guide	17.32 mm	0.682 in
Intake Manifold		

Engine Mechanical Specifications (LM7 VIN T) (cont'd)

Application	Specification	
	Metric	English
Surface Flatness – Measured at Gasket Sealing Surfaces and Measured Within a 200 mm (7.87 in) Area that Includes Two Runner Port Openings	0.3 mm	0.118 in
Lubrication System		
Oil Capacity – with Filter	5.68 Liters	6.0 Quarts
Oil Capacity – without Filter	4.73 Liters	5.0 Quarts
Oil Pressure – Minimum – Hot	41 kPa at 1,000 engine RPM 124 kPa at 2,000 engine RPM 165 kPa at 4,000 engine RPM	6 psig at 1,000 engine RPM 18 psig at 2,000 engine RPM 24 psig at 4,000 engine RPM
Oil Pan		
Front Cover Alignment – at Oil Pan Surface	0.0–0.5 mm	0.0–0.02 in
Rear Cover Alignment – at Oil Pan Surface	0.0–0.5 mm	0.0–0.02 in
Oil Pan Alignment – to Rear of Engine Block at Transmission Bell Housing Mounting Surface	0.0–0.25 mm	0.0–0.01 in
Piston Rings		
Piston Ring End Gap – First Compression Ring – Measured in Cylinder Bore – Production	0.23–0.44 mm	0.009–0.017 in
Piston Ring End Gap – First Compression Ring – Measured in Cylinder Bore – Service	0.23–0.5 mm	0.009–0.0196 in
Piston Ring End Gap – Second Compression Ring – Measured in Cylinder Bore – Production	0.44–0.7 mm	0.017–0.027 in
Piston Ring End Gap – Second Compression Ring – Measured in Cylinder Bore – Service	0.44–0.76 mm	0.0173–0.03 in
Piston Ring End Gap – Oil Control Ring – Measured in Cylinder Bore – Production	0.18–0.75 mm	0.007–0.029 in
Piston Ring End Gap – Oil Control Ring – Measured in Cylinder Bore – Service	0.18–0.81 mm	0.007–0.032 in
Piston Ring to Groove Clearance – First Compression Ring – Production	0.04–0.085 mm	0.00157–0.00335 in
Piston Ring to Groove Clearance – First Compression Ring – Service	0.04–0.085 mm	0.00157–0.00335 in
Piston Ring to Groove Clearance – Second Compression Ring – Production	0.04–0.078 mm	0.00157–0.0031 in
Piston Ring to Groove Clearance – Second Compression Ring – Service	0.04–0.078 mm	0.00157–0.0031 in
Piston Ring to Groove Clearance – Oil Control Ring – Production	0.012–0.2 mm	0.0005–0.0078 in
Piston Ring to Groove Clearance – Oil Control Ring – Service	0.012–0.2 mm	0.0005–0.0078 in
Pistons and Pins		
Piston – Piston Diameter – Measured Over Skirt Coating	96.002–96.036 mm	3.779–3.78 in
Piston – Piston to Bore Clearance – Production	–0.036 to 0.016 mm	–0.0014 to 0.0006 in
Piston – Piston to Bore Clearance – Service Limit with Skirt Coating Worn Off	0.071 mm	0.0028 in
Pin – Piston Pin Fit in Connecting Rod Bore	0.02–0.043 mm – interference	0.00078–0.00169 in – interference
Pin – Piston Pin Clearance to Piston Pin Bore – Production	0.007–0.02 mm	0.00027–0.00078 in
Pin – Piston Pin Clearance to Piston Pin Bore – Service	0.007–0.021 mm	0.00027–0.00082 in
Pin – Piston Pin Diameter	23.997–24.0 mm	0.9447–0.9448 in
Valve System		
Valves – Valve Face Angle	45 degrees	
Valves – Valve Face Width	1.25 mm	0.05 in

Engine Mechanical Specifications (LM7 VIN T) (cont'd)

Application	Specification	
	Metric	English
Valves – Valve Lash	Net Lash – No Adjustment	
Valves – Valve Lift – Intake	11.6 mm	0.457 in
Valves – Valve Lift – Exhaust	11.85 mm	0.466 in
Valves – Valve Seat Angle	46 degrees	
Valves – Valve Seat Runout	0.05 mm	0.002 in
Valves – Valve Seat Width – Exhaust	1.78 mm	0.07 in
Valves – Seat Width – Intake	1.02 mm	0.04 in
Valves – Valve Stem Diameter – Production	7.955–7.976 mm	0.313–0.314 in
Valves – Valve Stem Diameter – Service	7.95 mm	0.313 in
Valves – Valve Stem-to-Guide Clearance – Production – Intake	0.025–0.066 mm	0.001–0.0026 in
Valves – Valve Stem-to-Guide Clearance – Service – Intake	0.093 mm	0.0037 in
Valves – Valve Stem-to-Guide Clearance – Production – Exhaust	0.025–0.066 mm	0.001–0.0026 in
Valves – Valve Stem-to-Guide Clearance – Service – Exhaust	0.093 mm	0.0037 in
Rocker Arms – Valve Rocker Arm Ratio	1.70:1	
Valve Springs – Valve Spring Free Length	52.9 mm	2.08 in
Valve Springs – Valve Spring Installed Height	45.75 mm	1.8 in
Valve Springs – Valve Spring Load – Closed	340 N at 45.75 mm	76 lb at 1.8 in
Valve Springs – Valve Spring Load – Open	980 N at 33.55 mm	220 lb at 1.32 in

SIE-ID = 824401 LMD = 03-jun-2002

Engine Mechanical Specifications (L59 VIN Z)

Application	Specification	
	Metric	English
General		
Engine Type	V 8	
Displacement	5.3L	325 CID
RPO	L59	
VIN	Z	
Bore	96.0–96.018 mm	3.779–3.78 in
Stroke	92.0 mm	3.622 in
Compression Ratio	9.45:1	
Firing Order	1–8–7–2–6–5–4–3	
Spark Plug Gap	1.524 mm	0.06 in
Block		
Camshaft Bearing Bore Diameter	55.063–55.088 mm	2.168–2.169 in
Crankshaft Main Bearing Bore Diameter	69.871–69.889 mm	2.75–2.751 in
Crankshaft Main Bearing Bore Out-of-Round	0.006 mm	0.0002 in
Cylinder Bore Diameter	96.0–96.018 mm	3.779–3.78 in
Cylinder Bore Taper – Thrust Side	0.018 mm	0.0007 in
Cylinder Head Deck Height – Measuring from the Centerline of Crankshaft to the Deck Face	234.57–234.82 mm	9.235–9.245 in
Cylinder Head Deck Surface Flatness – Measured Within a 152.4 mm (6.0 in) Area	0.11 mm	0.004 in
Cylinder Head Deck Surface Flatness – Measuring the Overall Length of the Block Deck	0.22 mm	0.008 in
Valve Lifter Bore Diameter	21.417–21.443 mm	0.843–0.844 in
Camshaft		
Camshaft End Play	0.025–0.305 mm	0.001–0.012 in

Engine Mechanical Specifications (L59 VIN Z) (cont'd)

Application	Specification	
	Metric	English
Camshaft Journal Diameter	54.99–55.04 mm	2.164–2.166 in
Camshaft Journal Out-of-Round	0.025 mm	0.001 in
Camshaft Lobe Lift – Exhaust	6.96 mm	0.274 in
Camshaft Lobe Lift – Intake	6.82 mm	0.268 in
Camshaft Runout – Measured at the Intermediate Journals	0.05 mm	0.002 in
Connecting Rod		
Connecting Rod Bearing Clearance – Production	0.023–0.065 mm	0.0009–0.0025 in
Connecting Rod Bearing Clearance – Service	0.023–0.076 mm	0.0009–0.003 in
Connecting Rod Bore Diameter – Bearing End	56.505–56.525 mm	2.224–2.225 in
Connecting Rod Bore Out-of-Round – Bearing End – Production	0.004–0.008 mm	0.00015–0.0003 in
Connecting Rod Bore Out-of-Round – Bearing End – Service	0.004–0.008 mm	0.00015–0.0003 in
Connecting Rod Side Clearance	0.11–0.51 mm	0.00433–0.02 in
Crankshaft		
Connecting Rod Journal Diameter – Production	53.318–53.338 mm	2.0991–2.0999 in
Connecting Rod Journal Diameter – Service	53.308 mm	2.0987 in
Connecting Rod Journal Out-of-Round – Production	0.005 mm	0.0002 in
Connecting Rod Journal Out-of-Round – Service	0.01 mm	0.0004 in
Connecting Rod Journal Taper – Maximum for 1/2 of Journal Length – Production	0.005 mm	0.0002 in
Connecting Rod Journal Taper – Maximum for 1/2 of Journal Length – Service	0.02 mm	0.00078 in
Crankshaft End Play	0.04–0.2 mm	0.0015–0.0078 in
Crankshaft Main Bearing Clearance – Production	0.02–0.052 mm	0.0008–0.0021 in
Crankshaft Main Bearing Clearance – Service	0.02–0.065 mm	0.0008–0.0025 in
Crankshaft Main Journal Diameter – Production	64.993–65.007 mm	2.558–2.559 in
Crankshaft Main Journal Diameter – Service	64.993 mm	2.558 in
Crankshaft Main Journal Out-of-Round – Production	0.003 mm	0.000118 in
Crankshaft Main Journal Out-of-Round – Service	0.008 mm	0.0003 in
Crankshaft Main Journal Taper – Production	0.01 mm	0.0004 in
Crankshaft Main Journal Taper – Service	0.02 mm	0.00078 in
Crankshaft Rear Flange Runout	0.05 mm	0.002 in
Crankshaft Reluctor Ring Runout – Measured 1.0 mm (0.04 in) Below Tooth Diameter	0.7 mm	0.028 in
Crankshaft Thrust Surface – Production	26.14–26.22 mm	1.029–1.0315 in
Crankshaft Thrust Surface – Service	26.22 mm	1.0315 in
Crankshaft Thrust Surface Runout	0.025 mm	0.001 in
Cylinder Head		
Cylinder Head Height/Thickness – Measured from the Cylinder Head Deck to the Valve Rocker Arm Cover Seal Surface	120.2 mm	4.732 in
Surface Flatness – Block Deck – Measured Within a 152.4 mm (6.0 in) Area	0.08 mm	0.003 in
Surface Flatness – Block Deck – Measuring the Overall Length of the Cylinder Head	0.1 mm	0.004 in
Surface Flatness – Exhaust Manifold Deck	0.13 mm	0.005 in
Surface Flatness – Intake Manifold Deck	0.08 mm	0.0031 in
Valve Guide Installed Height – Measured from the Spring Seat Surface to the Top of the Guide	17.32 mm	0.682 in
Intake Manifold		

Engine Mechanical Specifications (L59 VIN Z) (cont'd)

Application	Specification	
	Metric	English
Surface Flatness – Measured at Gasket Sealing Surfaces and Measured Within a 200 mm (7.87 in) Area that Includes Two Runner Port Openings	0.3 mm	0.118 in
Lubrication System		
Oil Capacity – with Filter	5.68 Liters	6.0 Quarts
Oil Capacity – without Filter	4.73 Liters	5.0 Quarts
Oil Pressure – Minimum – Hot	41 kPa at 1,000 engine RPM 124 kPa at 2,000 engine RPM 165 kPa at 4,000 engine RPM	6 psig at 1,000 engine RPM 18 psig at 2,000 engine RPM 24 psig at 4,000 engine RPM
Oil Pan		
Front Cover Alignment – at Oil Pan Surface	0.0–0.5 mm	0.0–0.02 in
Rear Cover Alignment – at Oil Pan Surface	0.0–0.5 mm	0.0–0.02 in
Oil Pan Alignment – to Rear of Engine Block at Transmission Bell Housing Mounting Surface	0.0–0.25 mm	0.0–0.01 in
Piston Rings		
Piston Ring End Gap – First Compression Ring – Measured in Cylinder Bore – Production	0.23–0.44 mm	0.009–0.017 in
Piston Ring End Gap – First Compression Ring – Measured in Cylinder Bore – Service	0.23–0.5 mm	0.009–0.0196 in
Piston Ring End Gap – Second Compression Ring – Measured in Cylinder Bore – Production	0.44–0.7 mm	0.017–0.027 in
Piston Ring End Gap – Second Compression Ring – Measured in Cylinder Bore – Service	0.44–0.76 mm	0.0173–0.03 in
Piston Ring End Gap – Oil Control Ring – Measured in Cylinder Bore – Production	0.18–0.75 mm	0.007–0.029 in
Piston Ring End Gap – Oil Control Ring – Measured in Cylinder Bore – Service	0.18–0.81 mm	0.007–0.032 in
Piston Ring to Groove Clearance – First Compression Ring – Production	0.04–0.085 mm	0.00157–0.00335 in
Piston Ring to Groove Clearance – First Compression Ring – Service	0.04–0.085 mm	0.00157–0.00335 in
Piston Ring to Groove Clearance – Second Compression Ring – Production	0.04–0.078 mm	0.00157–0.0031 in
Piston Ring to Groove Clearance – Second Compression Ring – Service	0.04–0.078 mm	0.00157–0.0031 in
Piston Ring to Groove Clearance – Oil Control Ring – Production	0.012–0.2 mm	0.0005–0.0078 in
Piston Ring to Groove Clearance – Oil Control Ring – Service	0.012–0.2 mm	0.0005–0.0078 in
Pistons and Pins		
Piston – Piston Diameter – Measured Over Skirt Coating	96.002–96.036 mm	3.779–3.78 in
Piston – Piston to Bore Clearance – Production	–0.036 to 0.016 mm	–0.0014 to 0.0006 in
Piston – Piston to Bore Clearance – Service Limit with Skirt Coating Worn Off	0.071 mm	0.0028 in
Pin – Piston Pin Fit in Connecting Rod Bore	0.02–0.043 mm – interference	0.00078–0.00169 in – interference
Pin – Piston Pin Clearance to Piston Pin Bore – Production	0.007–0.02 mm	0.00027–0.00078 in
Pin – Piston Pin Clearance to Piston Pin Bore – Service	0.007–0.021 mm	0.00027–0.00082 in
Pin – Piston Pin Diameter	23.997–24.0 mm	0.9447–0.9448 in
Valve System		
Valves – Valve Face Angle	45 degrees	
Valves – Valve Face Width	1.25 mm	0.05 in

Engine Mechanical Specifications (L59 VIN Z) (cont'd)

Application	Specification	
	Metric	English
Valves – Valve Lash	Net Lash – No Adjustment	
Valves – Valve Lift – Intake	11.6 mm	0.457 in
Valves – Valve Lift – Exhaust	11.85 mm	0.466 in
Valves – Valve Seat Angle	46 degrees	
Valves – Valve Seat Runout	0.05 mm	0.002 in
Valves – Valve Seat Width – Exhaust	1.78 mm	0.07 in
Valves – Seat Width – Intake	1.02 mm	0.04 in
Valves – Valve Stem Diameter – Production	7.955–7.976 mm	0.313–0.314 in
Valves – Valve Stem Diameter – Service	7.95 mm	0.313 in
Valves – Valve Stem-to-Guide Clearance – Production – Intake	0.025–0.066 mm	0.001–0.0026 in
Valves – Valve Stem-to-Guide Clearance – Service – Intake	0.093 mm	0.0037 in
Valves – Valve Stem-to-Guide Clearance – Production – Exhaust	0.025–0.066 mm	0.001–0.0026 in
Valves – Valve Stem-to-Guide Clearance – Service – Exhaust	0.093 mm	0.0037 in
Rocker Arms – Valve Rocker Arm Ratio	1.70:1	
Valve Springs – Valve Spring Free Length	52.9 mm	2.08 in
Valve Springs – Valve Spring Installed Height	45.75 mm	1.8 in
Valve Springs – Valve Spring Load – Closed	340 N at 45.75 mm	76 lb at 1.8 in
Valve Springs – Valve Spring Load – Open	980 N at 33.55 mm	220 lb at 1.32 in

SIE-ID = 823797 LMD = 03-jun-2002

Engine Mechanical Specifications (LQ4 VIN U)

Application	Specification	
	Metric	English
General		
Engine Type	V 8	
Displacement	6.0L	364 CID
RPO	LQ4	
VIN	U	
Bore	101.618–101.636 mm	4.0007–4.0014 in
Stroke	92.0 mm	3.622 in
Compression Ratio	9.40:1	
Firing Order	1–8–7–2–6–5–4–3	
Spark Plug Gap	1.524 mm	0.06 in
Block		
Camshaft Bearing Bore Diameter	55.063–55.088 mm	2.168–2.169 in
Crankshaft Main Bearing Bore Diameter	69.871–69.889 mm	2.75–2.751 in
Crankshaft Main Bearing Bore Out-of-Round	0.006 mm	0.0002 in
Cylinder Bore Diameter	101.618–101.636 mm	4.0007–4.0017 in
Cylinder Bore Taper – Thrust Side	0.018 mm	0.0007 in
Cylinder Head Deck Height – Measuring from the Centerline of Crankshaft to the Deck Face	234.57–234.82 mm	9.235–9.245 in
Cylinder Head Deck Surface Flatness – Measured within a 152.4 mm (6.0 in) Area	0.11 mm	0.004 in
Cylinder Head Deck Surface Flatness – Measuring the Overall Length of the Block Deck	0.22 mm	0.008 in
Valve Lifter Bore Diameter	21.417–21.443 mm	0.843–0.844 in
Camshaft		
Camshaft End Play	0.025–0.305 mm	0.001–0.012 in

Engine Mechanical Specifications (LQ4 VIN U) (cont'd)

Application	Specification	
	Metric	English
Camshaft Journal Diameter	54.99–55.04 mm	2.164–2.166 in
Camshaft Journal Out-of-Round	0.025 mm	0.001 in
Camshaft Lobe Lift – Exhaust	7.13 mm	0.281 in
Camshaft Lobe Lift – Intake	6.96 mm	0.274 in
Camshaft Runout – Measured at the Intermediate Journals	0.05 mm	0.002 in
Connecting Rod		
Connecting Rod Bearing Clearance – Production	0.023–0.065 mm	0.0009–0.0025 in
Connecting Rod Bearing Clearance – Service	0.023–0.076 mm	0.0009–0.003 in
Connecting Rod Bore Diameter – Bearing End	56.505–56.525 mm	2.224–2.225 in
Connecting Rod Bore Out-of-Round – Bearing End – Production	0.006 mm	0.0002 in
Connecting Rod Bore Out-of-Round – Bearing End – Service	0.006 mm	0.0002 in
Connecting Rod Side Clearance	0.11–0.51 mm	0.00433–0.02 in
Crankshaft		
Connecting Rod Journal Diameter – Production	53.318–53.338 mm	2.0991–2.0999 in
Connecting Rod Journal Diameter – Service	53.308 mm	2.0987 in
Connecting Rod Journal Out-of-Round – Production	0.005 mm	0.0002 in
Connecting Rod Journal Out-of-Round – Service	0.01 mm	0.0004 in
Connecting Rod Journal Taper – Maximum for 1/2 of Journal Length – Production	0.005 mm	0.0002 in
Connecting Rod Journal Taper – Maximum for 1/2 of Journal Length – Service	0.02 mm	0.00078 in
Crankshaft End Play	0.04–0.2 mm	0.0015–0.0078 in
Crankshaft Main Bearing Clearance – Production	0.02–0.052 mm	0.0008–0.0021 in
Crankshaft Main Bearing Clearance – Service	0.02–0.065 mm	0.0008–0.0025 in
Crankshaft Main Journal Diameter – Production	64.993–65.007 mm	2.558–2.559 in
Crankshaft Main Journal Diameter – Service	64.993 mm	2.558 in
Crankshaft Main Journal Out-of-Round – Production	0.003 mm	0.000118 in
Crankshaft Main Journal Out-of-Round – Service	0.008 mm	0.0003 in
Crankshaft Main Journal Taper – Production	0.01 mm	0.0004 in
Crankshaft Main Journal Taper – Service	0.02 mm	0.00078 in
Crankshaft Rear Flange Runout	0.05 mm	0.002 in
Crankshaft Reluctor Ring Runout – Measured 1.0 mm (0.04 in) Below Tooth Diameter	0.7 mm	0.028 in
Crankshaft Thrust Surface – Production	26.14–26.22 mm	1.029–1.0315 in
Crankshaft Thrust Surface – Service	26.22 mm	1.0315 in
Crankshaft Thrust Surface Runout	0.025 mm	0.001 in
Cylinder Head		
Cylinder Head Height/Thickness – Measured from the Cylinder Head Deck to the Valve Rocker Arm Cover Seal Surface	120.2 mm	4.732 in
Surface Flatness – Block Deck – Measured Within a 152.4 mm (6.0 in) Area	0.08 mm	0.003 in
Surface Flatness – Block Deck – Measuring the Overall Length of the Cylinder Head	0.1 mm	0.004 in
Surface Flatness – Exhaust Manifold Deck	0.13 mm	0.005 in
Surface Flatness – Intake Manifold Deck	0.08 mm	0.0031 in
Valve Guide Installed Height – Measured from the Spring Seat Surface to the Top of the Guide	17.32 mm	0.682 in
Intake Manifold		

Engine Mechanical Specifications (LQ4 VIN U) (cont'd)

Application	Specification	
	Metric	English
Surface Flatness – Measured at Gasket Sealing Surfaces and Measured Within a 200 mm (7.87 in) Area that Includes Two Runner Port Openings	0.3 mm	0.118 in
Lubrication System		
Oil Capacity – with Filter	5.68 Liters	6.0 Quarts
Oil Capacity – without Filter	4.73 Liters	5.0 Quarts
Oil Pressure – Minimum – Hot	41 kPa at 1,000 engine RPM 124 kPa at 2,000 engine RPM 165 kPa at 4,000 engine RPM	6 psig at 1,000 engine RPM 18 psig at 2,000 engine RPM 24 psig at 4,000 engine RPM
Oil Pan		
Front Cover Alignment – at Oil Pan Surface	0.0–0.5 mm	0.0–0.02 in
Rear Cover Alignment – at Oil Pan Surface	0.0–0.5 mm	0.0–0.02 in
Oil Pan Alignment – to Rear of Engine Block at Transmission Bell Housing Mounting Surface	0.0–0.25 mm	0.0–0.01 in
Piston Rings		
Piston Ring End Gap – First Compression Ring – Measured in Cylinder Bore – Production	0.31–0.52 mm	0.012–0.02 in
Piston Ring End Gap – First Compression Ring – Measured in Cylinder Bore – Service	0.31–0.59 mm	0.0122–0.023 in
Piston Ring End Gap – Second Compression Ring – Measured in Cylinder Bore – Production	0.51–0.77 mm	0.02–0.03 in
Piston Ring End Gap – Second Compression Ring – Measured in Cylinder Bore – Service	0.51–0.84 mm	0.02–0.033 in
Piston Ring End Gap – Oil Control Ring – Measured in Cylinder Bore – Production	0.31–0.87 mm	0.0122–0.034 in
Piston Ring End Gap – Oil Control Ring – Measured in Cylinder Bore – Service	0.31–0.94 mm	0.0122–0.037 in
Piston Ring to Groove Clearance – First Compression Ring – Production	0.04–0.08 mm	0.00157–0.0031 in
Piston Ring to Groove Clearance – First Compression Ring – Service	0.04–0.08 mm	0.00157–0.0031 in
Piston Ring to Groove Clearance – Second Compression Ring – Production	0.039–0.079 mm	0.0015–0.0031 in
Piston Ring to Groove Clearance – Second Compression Ring – Service	0.039–0.079 mm	0.0015–0.0031 in
Piston Ring to Groove Clearance – Oil Control Ring – Production	0.015–0.199 mm	0.0006–0.0078 in
Piston Ring to Groove Clearance – Oil Control Ring – Service	0.015–0.199 mm	0.0006–0.0078 in
Pistons and Pins		
Piston – Piston Diameter – Measured Over Skirt Coating	101.606–101.640 mm	4.0002–4.0016 in
Piston – Piston to Bore Clearance – Production	0.022–0.03 mm – interference	0.0009–0.0012 in – interference
Piston – Piston to Bore Clearance – Service Limit with Skirt Coating Worn Off	0.07 mm	0.0028 in
Pin – Piston Pin Fit in Connecting Rod Bore	0.02–0.043 mm – interference	0.00078–0.00169 in – interference
Pin – Piston Pin Clearance to Piston Pin Bore – Production	0.011–0.018 mm	0.0004–0.0007 in
Pin – Piston Pin Clearance to Piston Pin Bore – Service	0.011–0.02 mm	0.0004–0.0008 in
Pin – Piston Pin Diameter	23.997–24.0 mm	0.9447–0.9448 in
Valve System		
Valves – Valve Face Angle	45 degrees	

Engine Mechanical Specifications (LQ4 VIN U) (cont'd)

Application	Specification	
	Metric	English
Valves – Valve Face Width	1.25 mm	0.05 in
Valves – Valve Lash	Net Lash – No Adjustment	
Valves – Valve Lift – Intake	11.79 mm	0.464 in
Valves – Valve Lift – Exhaust	12.16 mm	0.479 in
Valves – Valve Seat Angle	46 degrees	
Valves – Valve Seat Runout	0.05 mm	0.002 in
Valves – Valve Seat Width – Exhaust	1.78 mm	0.07 in
Valves – Valve Seat Width – Intake	1.02 mm	0.04 in
Valves – Valve Stem Diameter – Production	7.955–7.976 mm	0.313–0.314 in
Valves – Valve Stem Diameter – Service	7.95 mm	0.313 in
Valves – Valve Stem-to-Guide Clearance – Production – Intake	0.025–0.066 mm	0.001–0.0026 in
Valves – Valve Stem-to-Guide Clearance – Service – Intake	0.093 mm	0.0037 in
Valves – Valve Stem-to-Guide Clearance – Production – Exhaust	0.025–0.066 mm	0.001–0.0026 in
Valves – Valve Stem-to-Guide Clearance – Service – Exhaust	0.093 mm	0.0037 in
Rocker Arms – Valve Rocker Arm Ratio	1.70:1	
Valve Springs – Valve Spring Free Length	52.9 mm	2.08 in
Valve Springs – Valve Spring Installed Height	45.75 mm	1.8 in
Valve Springs – Valve Spring Load – Closed	340 N at 45.75 mm	76 lb at 1.8 in
Valve Springs – Valve Spring Load – Open	980 N at 33.55 mm	220 lb at 1.32 in

SIE-ID = 824402 LMD = 03-jun-2002

Engine Mechanical Specifications (LQ9 VIN N)

Application	Specification	
	Metric	English
General		
Engine Type	V 8	
Displacement	6.0L	364 CID
RPO	LQ9	
VIN	N	
Bore	101.618–101.636 mm	4.0007–4.0014 in
Stroke	92.0 mm	3.622 in
Compression Ratio	10.0:1	
Firing Order	1–8–7–2–6–5–4–3	
Spark Plug Gap	1.524 mm	0.06 in
Block		
Camshaft Bearing Bore Diameter	55.063–55.088 mm	2.168–2.169 in
Crankshaft Main Bearing Bore Diameter	69.871–69.889 mm	2.75–2.751 in
Crankshaft Main Bearing Bore Out-of-Round	0.006 mm	0.0002 in
Cylinder Bore Diameter	101.618–101.636 mm	4.0007–4.0017 in
Cylinder Bore Taper – Thrust Side	0.018 mm	0.0007 in
Cylinder Head Deck Height – Measuring from the Centerline of Crankshaft to the Deck Face	234.57–234.82 mm	9.235–9.245 in
Cylinder Head Deck Surface Flatness – Measured within a 152.4 mm (6.0 in) Area	0.11 mm	0.004 in
Cylinder Head Deck Surface Flatness – Measuring the Overall Length of the Block Deck	0.22 mm	0.008 in
Valve Lifter Bore Diameter	21.417–21.443 mm	0.843–0.844 in
Camshaft		

Engine Mechanical Specifications (LQ9 VIN N) (cont'd)

Application	Specification	
	Metric	English
Camshaft End Play	0.025–0.305 mm	0.001–0.012 in
Camshaft Journal Diameter	54.99–55.04 mm	2.164–2.166 in
Camshaft Journal Out-of-Round	0.025 mm	0.001 in
Camshaft Lobe Lift – Exhaust	7.13 mm	0.281 in
Camshaft Lobe Lift – Intake	6.96 mm	0.274 in
Camshaft Runout – Measured at the Intermediate Journals	0.05 mm	0.002 in
Connecting Rod		
Connecting Rod Bearing Clearance – Production	0.023–0.065 mm	0.0009–0.0025 in
Connecting Rod Bearing Clearance – Service	0.023–0.076 mm	0.0009–0.003 in
Connecting Rod Bore Diameter – Bearing End	56.505–56.525 mm	2.224–2.225 in
Connecting Rod Bore Out-of-Round – Bearing End – Production	0.006 mm	0.00023 in
Connecting Rod Bore Out-of-Round – Bearing End – Service	0.004–0.008 mm	0.00015–0.0003 in
Connecting Rod Side Clearance	0.11–0.51 mm	0.00433–0.02 in
Crankshaft		
Connecting Rod Journal Diameter – Production	53.318–53.338 mm	2.0991–2.0999 in
Connecting Rod Journal Diameter – Service	53.308 mm	2.0987 in
Connecting Rod Journal Out-of-Round – Production	0.005 mm	0.0002 in
Connecting Rod Journal Out-of-Round – Service	0.01 mm	0.0004 in
Connecting Rod Journal Taper – Maximum for 1/2 of Journal Length – Production	0.005 mm	0.0002 in
Connecting Rod Journal Taper – Maximum for 1/2 of Journal Length – Service	0.02 mm	0.00078 in
Crankshaft End Play	0.04–0.2 mm	0.0015–0.0078 in
Crankshaft Main Bearing Clearance – Production	0.02–0.052 mm	0.0008–0.0021 in
Crankshaft Main Bearing Clearance – Service	0.02–0.065 mm	0.0008–0.0025 in
Crankshaft Main Journal Diameter – Production	64.993–65.007 mm	2.558–2.559 in
Crankshaft Main Journal Diameter – Service	64.993 mm	2.558 in
Crankshaft Main Journal Out-of-Round – Production	0.003 mm	0.000118 in
Crankshaft Main Journal Out-of-Round – Service	0.008 mm	0.0003 in
Crankshaft Main Journal Taper – Production	0.01 mm	0.0004 in
Crankshaft Main Journal Taper – Service	0.02 mm	0.00078 in
Crankshaft Rear Flange Runout	0.05 mm	0.002 in
Crankshaft Reluctor Ring Runout – Measured 1.0 mm (0.04 in) Below Tooth Diameter	0.7 mm	0.028 in
Crankshaft Thrust Surface – Production	26.14–26.22 mm	1.029–1.0315 in
Crankshaft Thrust Surface – Service	26.22 mm	1.0315 in
Crankshaft Thrust Surface Runout	0.025 mm	0.001 in
Cylinder Head		
Cylinder Head Height/Thickness – Measured from the Cylinder Head Deck to the Valve Rocker Arm Cover Seal Surface	120.2 mm	4.732 in
Surface Flatness – Block Deck – Measured Within a 152.4 mm (6.0 in) Area	0.08 mm	0.003 in
Surface Flatness – Block Deck – Measuring the Overall Length of the Cylinder Head	0.1 mm	0.004 in
Surface Flatness – Exhaust Manifold Deck	0.13 mm	0.005 in
Surface Flatness – Intake Manifold Deck	0.08 mm	0.0031 in
Valve Guide Installed Height – Measured from the Spring Seat Surface to the Top of the Guide	17.32 mm	0.682 in
Intake Manifold		

Engine Mechanical Specifications (LQ9 VIN N) (cont'd)

Application	Specification	
	Metric	English
Surface Flatness – Measured at Gasket Sealing Surfaces and Measured Within a 200 mm (7.87 in) Area that Includes Two Runner Port Openings	0.3 mm	0.118 in
Lubrication System		
Oil Capacity – with Filter	5.68 Liters	6.0 Quarts
Oil Capacity – without Filter	4.73 Liters	5.0 Quarts
Oil Pressure – Minimum – Hot	41 kPa at 1,000 engine RPM 124 kPa at 2,000 engine RPM 165 kPa at 4,000 engine RPM	6 psig at 1,000 engine RPM 18 psig at 2,000 engine RPM 24 psig at 4,000 engine RPM
Oil Pan		
Front Cover Alignment – at Oil Pan Surface	0.0–0.5 mm	0.0–0.02 in
Rear Cover Alignment – at Oil Pan Surface	0.0–0.5 mm	0.0–0.02 in
Oil Pan Alignment – to Rear of Engine Block at Transmission Bell Housing Mounting Surface	0.0–0.25 mm	0.0–0.01 in
Piston Rings		
Piston Ring End Gap – First Compression Ring – Measured in Cylinder Bore – Production	0.31–0.52 mm	0.012–0.02 in
Piston Ring End Gap – First Compression Ring – Measured in Cylinder Bore – Service	0.31–0.59 mm	0.0122–0.023 in
Piston Ring End Gap – Second Compression Ring – Measured in Cylinder Bore – Production	0.51–0.77 mm	0.02–0.03 in
Piston Ring End Gap – Second Compression Ring – Measured in Cylinder Bore – Service	0.51–0.84 mm	0.02–0.033 in
Piston Ring End Gap – Oil Control Ring – Measured in Cylinder Bore – Production	0.31–0.87 mm	0.0122–0.034 in
Piston Ring End Gap – Oil Control Ring – Measured in Cylinder Bore – Service	0.31–0.94 mm	0.0122–0.037 in
Piston Ring to Groove Clearance – First Compression Ring – Production	0.035–0.08 mm	0.0014–0.0031 in
Piston Ring to Groove Clearance – First Compression Ring – Service	0.035–0.08 mm	0.0014–0.0031 in
Piston Ring to Groove Clearance – Second Compression Ring – Production	0.034–0.079 mm	0.0013–0.003 in
Piston Ring to Groove Clearance – Second Compression Ring – Service	0.034–0.079 mm	0.0013–0.003 in
Piston Ring to Groove Clearance – Oil Control Ring – Production	0.012–0.2 mm	0.00047–0.00078 in
Piston Ring to Groove Clearance – Oil Control Ring – Service	0.012–0.2 mm	0.00047–0.00078 in
Pistons and Pins		
Piston – Piston Diameter – Measured Over Coating – at Size Point	101.611–101.642 mm	4.0–4.001 in
Piston – Piston to Bore Clearance – Production	–0.022 to 0.030 mm	–0.0009 to 0.0012 in
Piston – Piston to Bore Clearance – With Skirt Coating Worn Off – Service	0.024–0.08 mm	0.00094–0.0031 in
Pin – Piston Pin Fit in Connecting Rod Bore – Production	0.007–0.02 mm	0.00027–0.00078 in
Pin – Piston Pin Fit in Connecting Rod Bore – Service	0.007–0.022 mm	0.00027–0.00086 in
Pin – Piston Pin Clearance to Piston Pin Bore – Production	0.002–0.01 mm	0.00008–0.0004 in
Pin – Piston Pin Clearance to Piston Pin Bore – Service	0.002–0.015 mm	0.0008–0.0006 in
Pin – Piston Pin Diameter	23.952–23.955 mm	0.943–0.943 in
Valve System		
Valves – Valve Face Angle	45 degrees	
Valves – Valve Face Width	1.25 mm	0.05 in

Engine Mechanical Specifications (LQ9 VIN N) (cont'd)

Application	Specification	
	Metric	English
Valves – Valve Lash	Net Lash – No Adjustment	
Valves – Valve Lift – Intake	11.79 mm	0.464 in
Valves – Valve Lift – Exhaust	12.16 mm	0.479 in
Valves – Valve Seat Angle	46 degrees	
Valves – Valve Seat Runout	0.05 mm	0.002 in
Valves – Valve Seat Width – Exhaust	1.78 mm	0.07 in
Valves – Valve Seat Width – Intake	1.02 mm	0.04 in
Valves – Valve Stem Diameter – Production	7.955–7.976 mm	0.313–0.314 in
Valves – Valve Stem Diameter – Service	7.95 mm	0.313 in
Valves – Valve Stem-to-Guide Clearance – Production – Intake	0.025–0.066 mm	0.001–0.0026 in
Valves – Valve Stem-to-Guide Clearance – Service – Intake	0.093 mm	0.0037 in
Valves – Valve Stem-to-Guide Clearance – Production – Exhaust	0.025–0.066 mm	0.001–0.0026 in
Valves – Valve Stem-to-Guide Clearance – Service – Exhaust	0.093 mm	0.0037 in
Rocker Arms – Valve Rocker Arm Ratio	1.70:1	
Valve Springs – Valve Spring Free Length	52.9 mm	2.08 in
Valve Springs – Valve Spring Installed Height	45.75 mm	1.8 in
Valve Springs – Valve Spring Load – Closed	340 N at 45.75 mm	76 lb at 1.8 in
Valve Springs – Valve Spring Load – Open	980 N at 33.55 mm	220 lb at 1.32 in

SIE-ID = 279678 LMD = 07-aug-2001

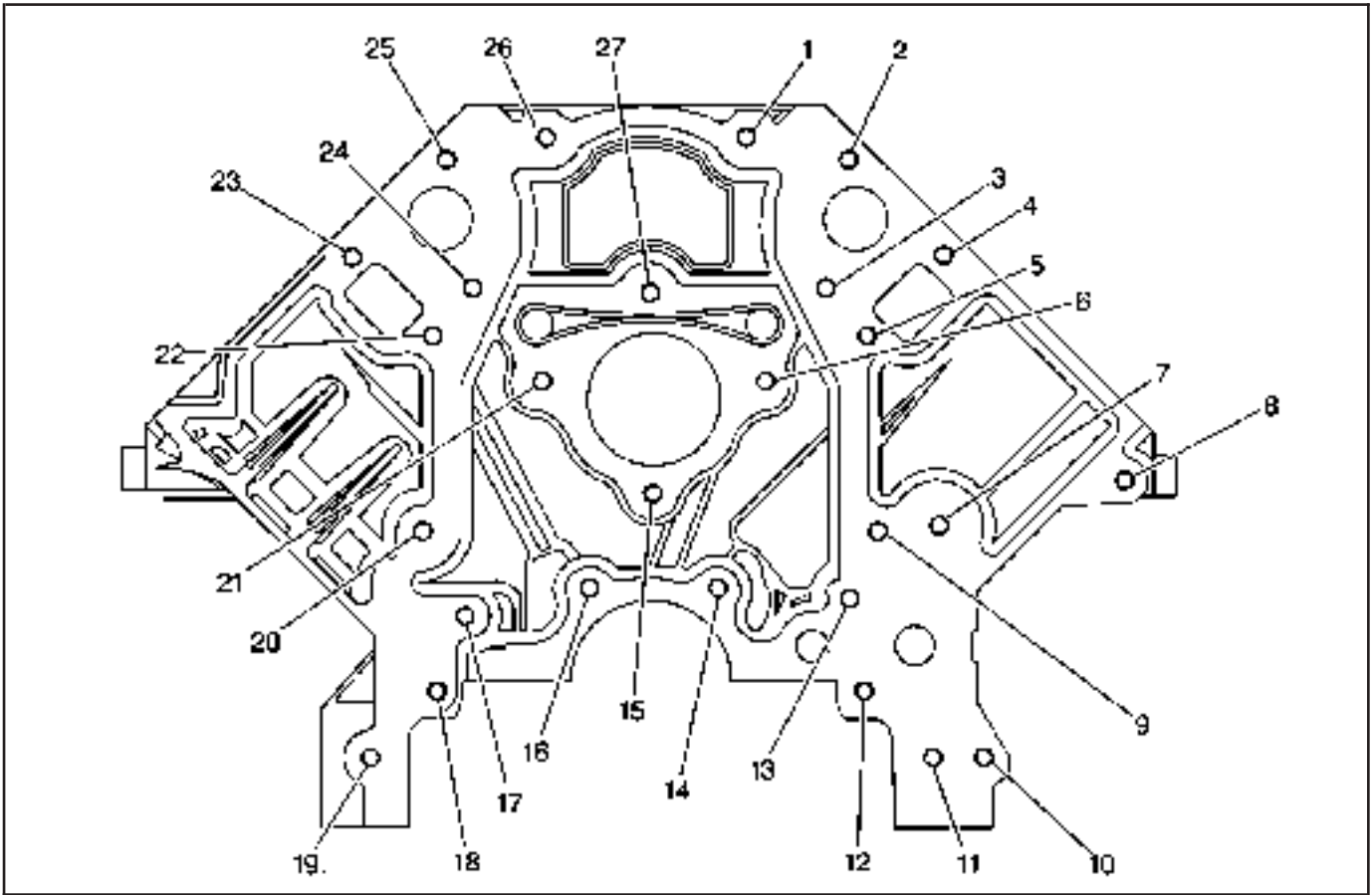
Sealers, Adhesives, and Lubricants

Application	Type of Material	GM Part Number	
		United States	Canada
Coolant Sensor Threads	Sealant	12346004	10953480
Cylinder Head Core Hole Plugs	Threadlock	12345382	10953489
Cylinder Head Expansion Plugs – Aluminum	Threadlock	12345382	10953489
Engine Block Front Oil Gallery Plug	Threadlock	12345382	10953489
Engine Block Plug Sealing Washers	Sealant	12346004	10953480
Engine Flywheel Bolt Threads	Threadlock	12345382	10953489
Engine Oil	5W-30 Oil	12345610	993193
Engine Oil Supplement	Fluorescent Dye	12345795	10953470
Exhaust Manifold Bolt Threads	Threadlock	12345493	10953488
Fuel Rail Bolt Threads	Threadlock	12345382	10953489
Ignition Coil and Bracket Bolts	Threadlock	12345382	10953489
Ignition Coil Bracket Bolts	Threadlock	12345382	10953489
Intake Manifold Bolt Threads	Threadlock	12345382	10953489
Oil Pan Surface at Front and Rear Covers	Sealant	12378190	—
Oil Pressure Sensor Threads	Sealant	12346004	10953480
Thread Repair Component Cleaner	Cleaner	12346139	10953463
Thread Repair Component Cleaner	Cleaner	12377981	10953463
Thread Repair Cutting Oil	Lubricant	1052864	992881

Thread Repair Specifications

SIE-ID = 741672 LMD = 08-aug-2000

Engine Block-Front View

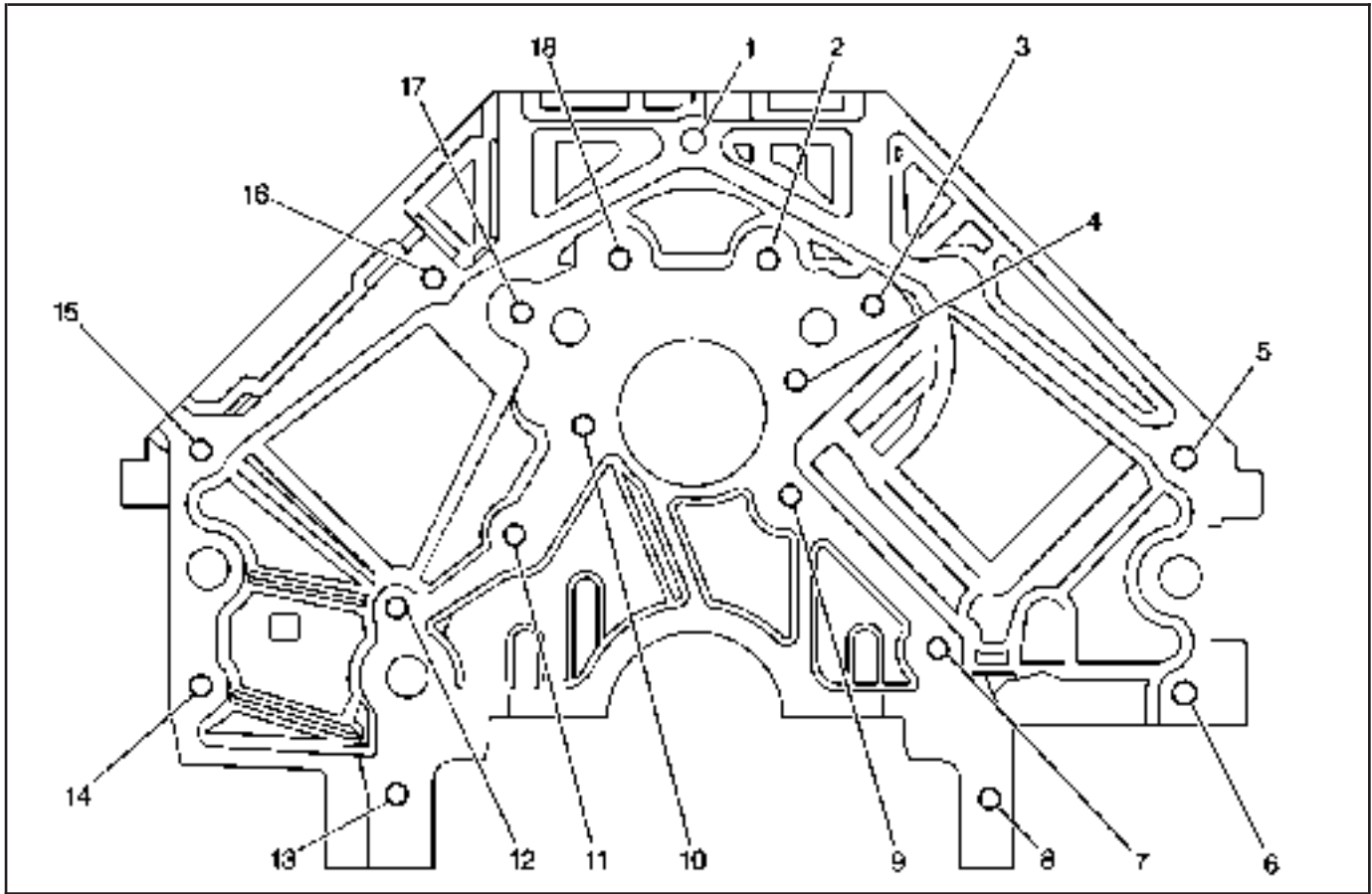


64583

Engine Block-Front View

Hole	Thread Size	Insert	Drill	Counterbore Tool	Tap	Driver	Drill Depth (Maximum) mm (in)	Tap Depth (Maximum) mm (in)
1-6	M8 x 1.25	J 42385-210	J 42385-206	J 42385-207	J 42385-208	J 42385-209	22.5 (0.885)	17.5 (0.688)
7	—	—	—	—	—	—	—	—
8	M10 x 1.5	J 42385-215	J 42385-211	J 42385-212	J 42385-213	J 42385-214	32.5 (1.28)	25.0 (0.984)
9	M8 x 1.25	J 42385-210	J 42385-206	J 42385-207	J 42385-208	J 42385-209	22.5 (0.885)	17.5 (0.688)
10	M10 x 1.5	J 42385-215	J 42385-211	J 42385-212	J 42385-213	J 42385-214	Thru	Thru
11-13	M8 x 1.25	J 42385-210	J 42385-206	J 42385-207	J 42385-208	J 42385-209	22.5 (0.885)	17.5 (0.688)
14	M8 x 1.25	J 42385-210	J 42385-206	J 42385-207	J 42385-208	J 42385-209	Thru	18.0 (0.708)
15	M8 x 1.25	J 42385-210	J 42385-206	J 42385-207	J 42385-208	J 42385-209	22.5 (0.885)	17.5 (0.688)
16	M8 x 1.25	J 42385-210	J 42385-206	J 42385-207	J 42385-208	J 42385-209	Thru	18.0 (0.708)
17-27	M8 x 1.25	J 42385-210	J 42385-206	J 42385-207	J 42385-208	J 42385-209	22.5 (0.885)	17.5 (0.688)

Engine Block-Rear View

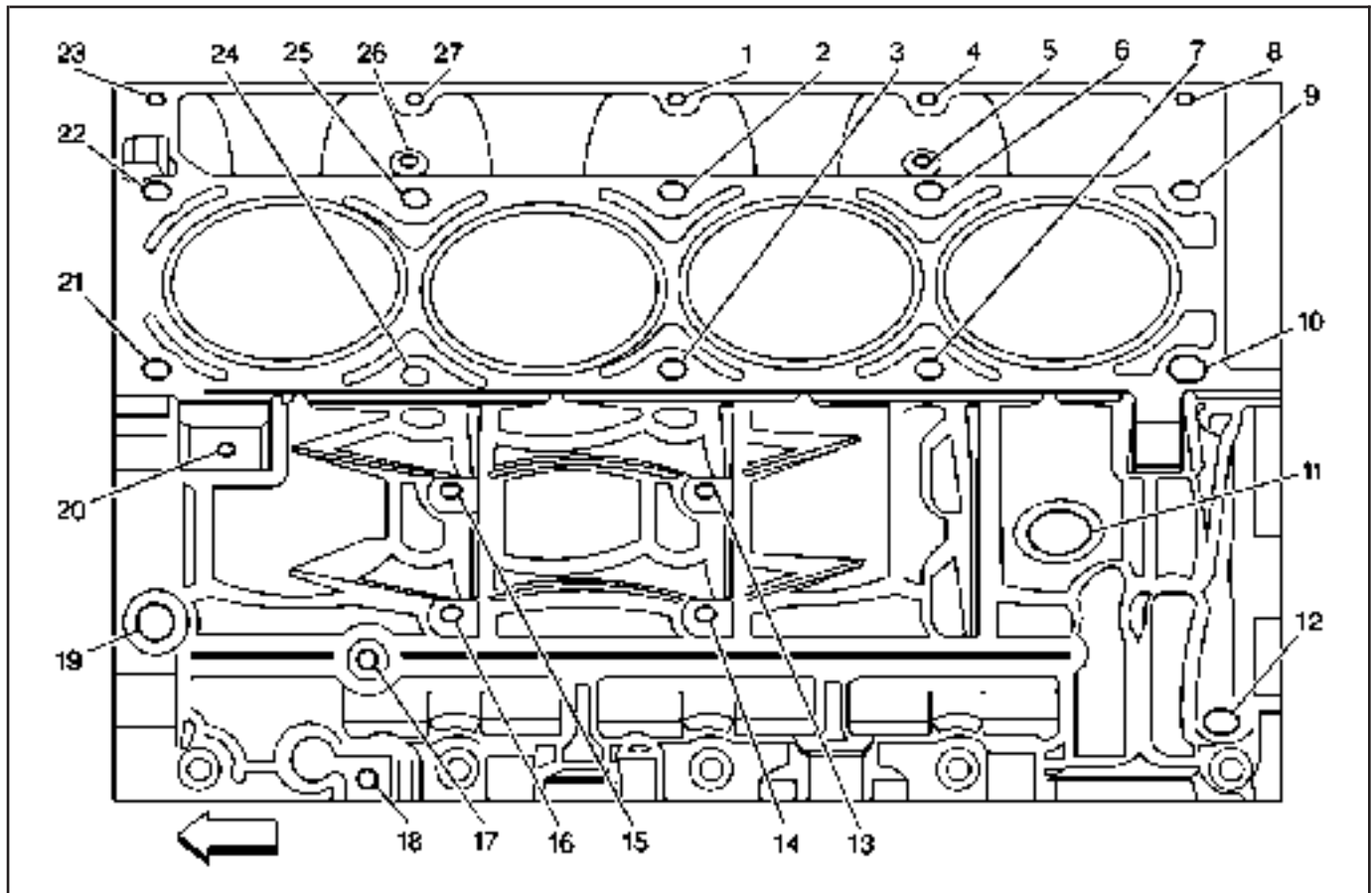


64590

Engine Block-Rear View

Hole	Thread Size	Insert	Drill	Counterbore Tool	Tap	Driver	Drill Depth (Maximum) mm (in)	Tap Depth (Maximum) mm (in)
1	M10 x 1.5	J 42385-215	J 42385-211	J 42385-212	J 42385-213	J 42385-214	27.0 (1.06)	21.5 (0.846)
2-4	M8 x 1.25	J 42385-210	J 42385-206	J 42385-207	J 42385-208	J 42385-209	22.5 (0.885)	17.5 (0.688)
5-6	M10 x 1.5	J 42385-215	J 42385-211	J 42385-212	J 42385-213	J 42385-214	27.0 (1.06)	21.5 (0.846)
7-13	M8 x 1.25	J 42385-210	J 42385-206	J 42385-207	J 42385-208	J 42385-209	22.5 (0.885)	17.5 (0.688)
14-16	M10 x 1.5	J 42385-215	J 42385-211	J 42385-212	J 42385-213	J 42385-214	27.0 (1.06)	21.5 (0.846)
17-18	M8 x 1.25	J 42385-210	J 42385-206	J 42385-207	J 42385-208	J 42385-209	22.5 (0.885)	17.5 (0.688)

Engine Block-Left Side View



260170

Engine Block-Left Side View

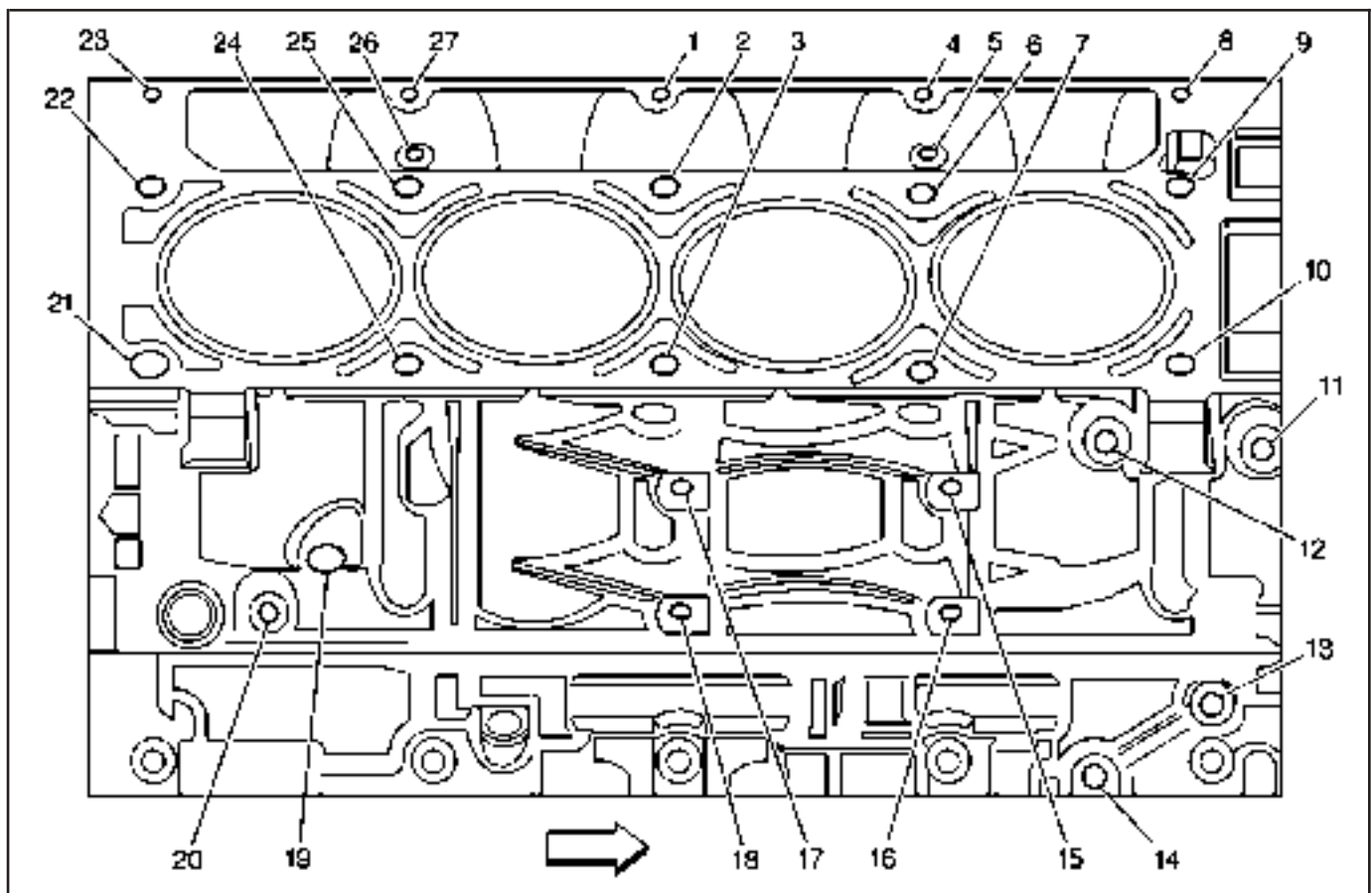
Hole	Thread Size	Insert	Drill	Counterbore Tool	Tap	Driver	Drill Depth (Maximum) mm (in)	Tap Depth (Maximum) mm (in)
1	M8 x 1.25	J 42385-210	J 42385-206	J 42385-207	J 42385-208	J 42385-209	26.5 (1.04)	19.0 (0.784)
2-3	M11 x 2.0	J 42385-108	J 42385-105	—	J 42385-106	J 42385-107	124.0 (4.88)	115.0 (4.52)
4	M8 x 1.25	J 42385-210	J 42385-206	J 42385-207	J 42385-208	J 42385-209	26.5 (1.04)	19.0 (0.784)
5	M6 x 1.0	J 42385-205	J 42385-201	J 42385-202	J 42385-203	J 42385-204	22.5 (0.885)	16.0 (0.629)
6-7	M11 x 2.0	J 42385-108	J 42385-105	—	J 42385-106	J 42385-107	124.0 (4.88)	115.0 (4.52)
8	M8 x 1.25	J 42385-210	J 42385-206	J 42385-207	J 42385-208	J 42385-209	26.5 (1.04)	19.0 (0.784)
9	M11 x 2.0	J 42385-108	J 42385-105	—	J 42385-106	J 42385-107	69.0 (2.72)	60.0 (2.36)
10	M11 x 2.0	J 42385-108	J 42385-105	—	J 42385-106	J 42385-107	124.0 (4.88)	115.0 (4.52)
11	M28 x 1.25	—	—	—	—	—	—	—
12	M16 x 1.5	—	—	—	—	—	—	—
13-16	M10 x 1.5	J 42385-215	J 42385-211	J 42385-212	J 42385-213	J 42385-214	29.0 (1.14)	23.0 (0.905)
17-18	M8 x 1.25	J 42385-210	J 42385-206	J 42385-207	J 42385-208	J 42385-209	21.0 (0.826)	16.0 (0.629)

Engine Block-Left Side View (cont'd)

Hole	Thread Size	Insert	Drill	Counterbore Tool	Tap	Driver	Drill Depth (Maximum) mm (in)	Tap Depth (Maximum) mm (in)
19	M16 x 1.5	—	—	—	—	—	—	—
20	M10 x 1.5	J 42385-215	J 42385-211	J 42385-212	J 42385-213	J 42385-214	27.0 (1.06)	21.5 (0.846)
21	M11 x 2.0	J 42385-108	J 42385-105	—	J 42385-106	J 42385-107	124.0 (4.88)	115.0 (4.52)
22	M11 x 2.0	J 42385-108	J 42385-105	—	J 42385-106	J 42385-107	69.0 (2.72)	60.0 (2.36)
23	M8 x 1.25	J 42385-210	J 42385-206	J 42385-207	J 42385-208	J 42385-209	26.5 (1.04)	19.0 (0.784)
24-25	M11 x 2.0	J 42385-108	J 42385-105	—	J 42385-106	J 42385-107	124.0 (4.88)	115.0 (4.52)
26	M6 x 1.0	J 42385-205	J 42385-201	J 42385-202	J 42385-203	J 42385-204	22.5 (0.885)	16.0 (0.629)
27	M8 x 1.25	J 42385-210	J 42385-206	J 42385-207	J 42385-208	J 42385-209	26.5 (1.04)	19.0 (0.784)

- Bolt holes 2, 3, 6, 7, 10, 21, 24, and 25 have a 85 mm (3.34 in) counterbore included in the 124.0 mm (4.88 in) drill depth.
- Bolt holes 9 and 22 have a 30 mm (1.18 in) counterbore included in the 69.0 mm (2.72 in) drill depth. Use sleeve J 42385-315 with the drill and tap.

Engine Block-Right Side View



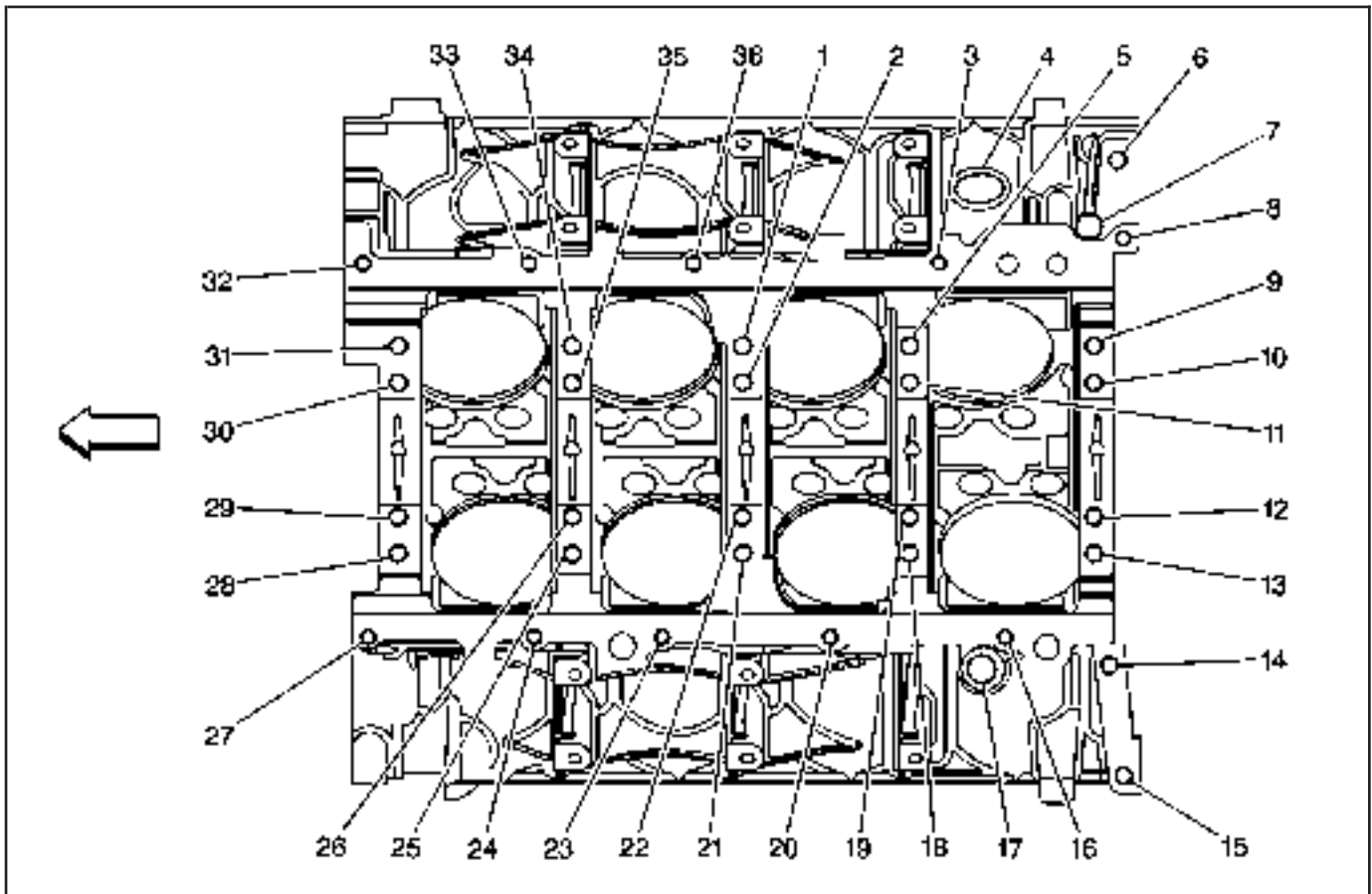
384700

Engine Block-Right Side View

Hole	Thread Size	Insert	Drill	Counterbore Tool	Tap	Driver	Drill Depth (Maximum) mm (in)	Tap Depth (Maximum) mm (in)
1	M8 x 1.25	J 42385-210	J 42385-206	J 42385-207	J 42385-208	J 42385-209	26.5 (1.04)	19.0 (0.784)
2-3	M11 x 2.0	J 42385-108	J 42385-105	—	J 42385-106	J 42385-107	124.0 (4.88)	115.0 (4.52)
4	M8 x 1.25	J 42385-210	J 42385-206	J 42385-207	J 42385-208	J 42385-209	26.5 (1.04)	19.0 (0.784)
5	M6 x 1.0	J 42385-205	J 42385-201	J 42385-202	J 42385-203	J 42385-204	22.5 (0.885)	15.0 (0.590)
6-7	M11 x 2.0	J 42385-108	J 42385-105	—	J 42385-106	J 42385-107	124.0 (4.88)	115.0 (4.52)
8	M8 x 1.25	J 42385-210	J 42385-206	J 42385-207	J 42385-208	J 42385-209	26.5 (1.04)	19.0 (0.784)
9	M11 x 2.0	J 42385-108	J 42385-105	—	J 42385-106	J 42385-107	69.0 (2.72)	60.0 (2.36)
10	M11 x 2.0	J 42385-108	J 42385-105	—	J 42385-106	J 42385-107	124.0 (4.88)	115.0 (4.52)
11-14	M10 x 1.5	J 42385-215	J 42385-211	J 42385-212	J 42385-213	J 42385-214	27.0 (1.06)	21.5 (0.846)
15-18	M10 x 1.5	J 42385-215	J 42385-211	J 42385-212	J 42385-213	J 42385-214	29.0 (1.14)	23.0 (0.905)
19	M16 x 1.5	—	—	—	—	—	—	—
20	M8 x 1.25	J 42385-210	J 42385-206	J 42385-207	J 42385-208	J 42385-209	22.5 (0.885)	17.5 (0.688)
21	M11 x 2.0	J 42385-108	J 42385-105	—	J 42385-106	J 42385-107	124.0 (4.88)	115.0 (4.52)
22	M11 x 2.0	J 42385-108	J 42385-105	—	J 42385-106	J 42385-107	69.0 (2.72)	60.0 (2.36)
23	M8 x 1.25	J 42385-210	J 42385-206	J 42385-207	J 42385-208	J 42385-209	26.5 (1.04)	19.0 (0.784)
24-25	M11 x 2.0	J 42385-108	J 42385-105	—	J 42385-106	J 42385-107	124.0 (4.88)	115.0 (4.52)
26	M6 x 1.0	J 42385-205	J 42385-201	J 42385-202	J 42385-203	J 42385-204	22.5 (0.885)	15.0 (0.590)
27	M8 x 1.25	J 42385-210	J 42385-206	J 42385-207	J 42385-208	J 42385-209	26.5 (1.04)	19.0 (0.784)

- Bolt holes 2, 3, 6, 7, 10, 21, 24, and 25 have a 85 mm (3.34 in) counterbore included in the 124.0 mm (4.88 in) drill depth.
- Bolt holes 9 and 22 have a 29 mm (1.18 in) counterbore included in the 69.0 mm (2.72 in) drill depth. Use sleeve J 42385-315 with the drill and tap.

Engine Block-Bottom View



260172

Engine Block-Bottom View

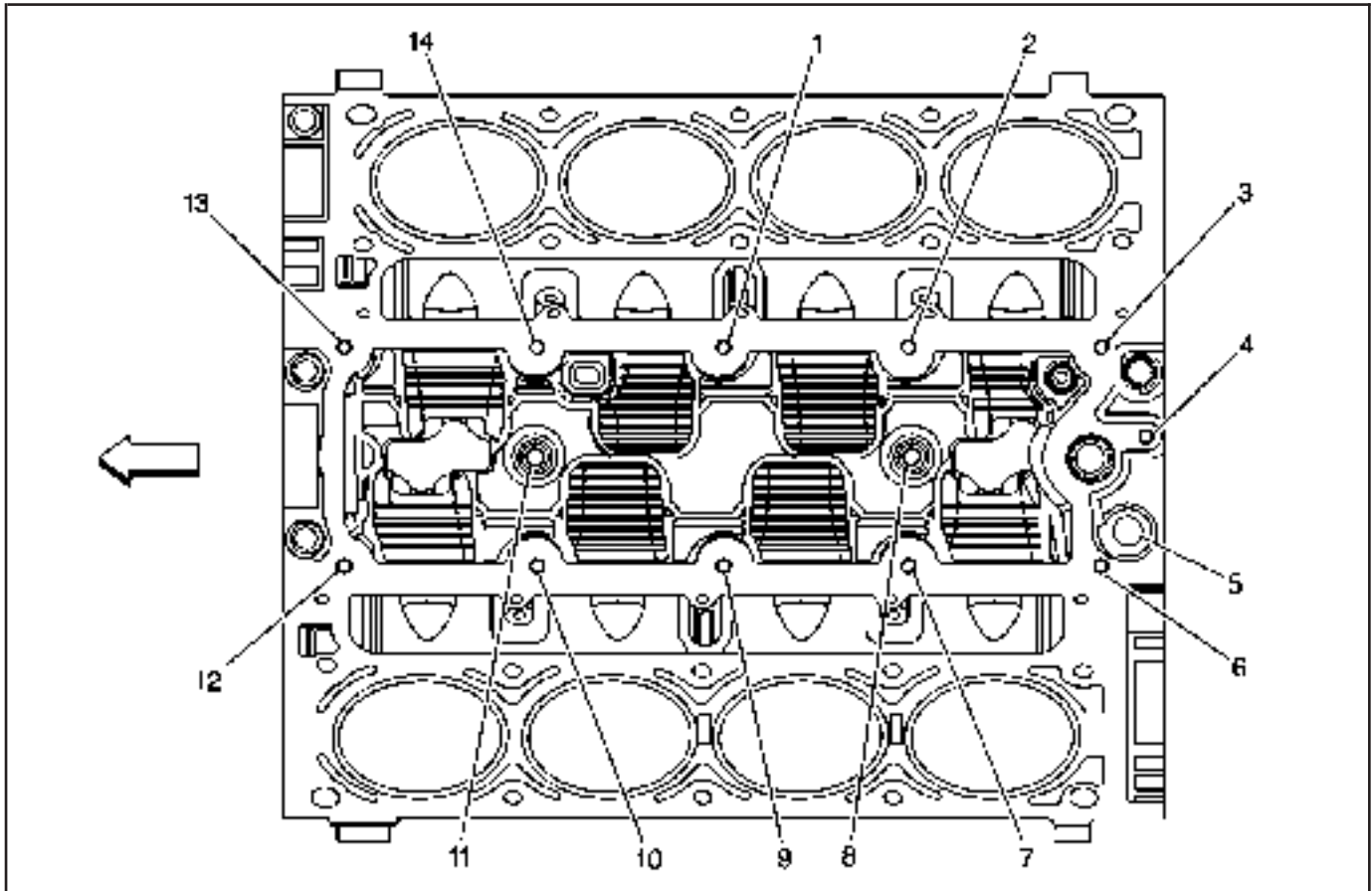
Hole	Thread Size	Insert	Drill	Counterbore Tool	Tap	Driver	Drill Depth (Maximum) mm (in)	Tap Depth (Maximum) mm (in)
1	M10 x 2.0	J 42385-104	J 42385-101	—	J 42385-102	J 42385-103	31.0 (1.22)	25.5 (1.0)
2	M10 x 2.0	J 42385-104	J 42385-101	—	J 42385-102	J 42385-103	53.5 (2.10)	44.0 (1.73)
3	M8 x 1.25	J 42385-210	J 42385-206	J 42385-207	J 42385-208	J 42385-209	22.5 (0.885)	17.5 (0.688)
4	M28 x 1.25	—	—	—	—	—	—	—
5	M10 x 2.0	J 42385-104	J 42385-101	—	J 42385-102	J 42385-103	53.5 (2.10)	44.0 (1.73)
6	N/A	—	—	—	—	—	—	—
7	M16 x 1.5	—	—	—	—	—	—	—
8	M8 x 1.25	J 42385-210	J 42385-206	J 42385-207	J 42385-208	J 42385-209	22.5 (0.885)	17.5 (0.688)
9	M10 x 2.0	J 42385-104	J 42385-101	—	J 42385-102	J 42385-103	31.0 (1.22)	25.5 (1.0)
10-12	M10 x 2.0	J 42385-104	J 42385-101	—	J 42385-102	J 42385-103	53.5 (2.10)	44.0 (1.73)
13	M10 x 2.0	J 42385-104	J 42385-101	—	J 42385-102	J 42385-103	31.0 (1.22)	25.5 (1.0)
14-15	M10 x 1.5	J 42385-215	J 42385-101	—	J 42385-213	J 42385-214	42.5 (1.67)	37.0 (1.45)

Engine Block-Bottom View (cont'd)

Hole	Thread Size	Insert	Drill	Counterbore Tool	Tap	Driver	Drill Depth (Maximum) mm (in)	Tap Depth (Maximum) mm (in)
16	M8 x 1.25	J 42385-210	J 42385-206	J 42385-207	J 42385-208	J 42385-209	22.5 (0.885)	17.5 (0.688)
17	M16 x 1.5	—	—	—	—	—	—	—
18	M10 x 2.0	J 42385-104	J 42385-101	—	J 42385-102	J 42385-103	31.0 (1.22)	25.5 (1.0)
19	M10 x 2.0	J 42385-104	J 42385-101	—	J 42385-102	J 42385-103	53.5 (2.10)	44.0 (1.73)
20	M8 x 1.25	J 42385-210	J 42385-206	J 42385-207	J 42385-208	J 42385-209	22.5 (0.885)	17.5 (0.688)
21	M10 x 2.0	J 42385-104	J 42385-101	—	J 42385-102	J 42385-103	31.0 (1.22)	25.5 (1.0)
22	M10 x 2.0	J 42385-104	J 42385-101	—	J 42385-102	J 42385-103	53.5 (2.10)	44.0 (1.73)
23-24	M8 x 1.25	J 42385-210	J 42385-206	J 42385-207	J 42385-208	J 42385-209	22.5 (0.885)	17.5 (0.688)
25	M10 x 2.0	J 42385-104	J 42385-101	—	J 42385-102	J 42385-103	31.0 (1.22)	25.5 (1.0)
26	M10 x 2.0	J 42385-104	J 42385-101	—	J 42385-102	J 42385-103	53.5 (2.10)	44.0 (1.73)
27	M8 x 1.25	J 42385-210	J 42385-206	J 42385-207	J 42385-208	J 42385-209	22.5 (0.885)	17.5 (0.688)
28	M10 x 2.0	J 42385-104	J 42385-101	—	J 42385-102	J 42385-103	31.0 (1.22)	25.5 (1.0)
29-30	M10 x 2.0	J 42385-104	J 42385-101	—	J 42385-102	J 42385-103	53.5 (2.10)	44.0 (1.73)
31	M10 x 2.0	J 42385-104	J 42385-101	—	J 42385-102	J 42385-103	31.0 (1.22)	25.5 (1.0)
32-33	M8 x 1.25	J 42385-210	J 42385-206	J 42385-207	J 42385-208	J 42385-209	22.5 (0.885)	17.5 (0.688)
34	M10 x 2.0	J 42385-104	J 42385-101	—	J 42385-102	J 42385-103	31.0 (1.22)	25.5 (1.0)
35	M10 x 2.0	J 42385-104	J 42385-101	—	J 42385-102	J 42385-103	53.5 (2.10)	44.0 (1.73)
36	M8 x 1.25	J 42385-210	J 42385-206	J 42385-207	J 42385-208	J 42385-209	22.5 (0.885)	17.5 (0.688)

- Bolt holes 2, 10, 11, 12, 19, 22, 26, 29, 30, and 35 have a 20.5 mm (0.807 in) counterbore included in the 53.5 mm (2.10 in) drill depth.
- Bolt holes 1, 5, 9, 13, 18, 21, 25, 28, 31, and 34 have a 1.5 mm (0.059 in) counterbore included in the 31.0 mm (1.22 in) drill depth. Use sleeve J 42385-316 with the drill and tap.
- Bolt holes 14 and 15 have a 11.5 mm (0.452 in) counterbore included in the 42.5 mm (1.67 in) drill depth. Use sleeve J 42385-311 with the drill and tap.

Engine Block-Top View

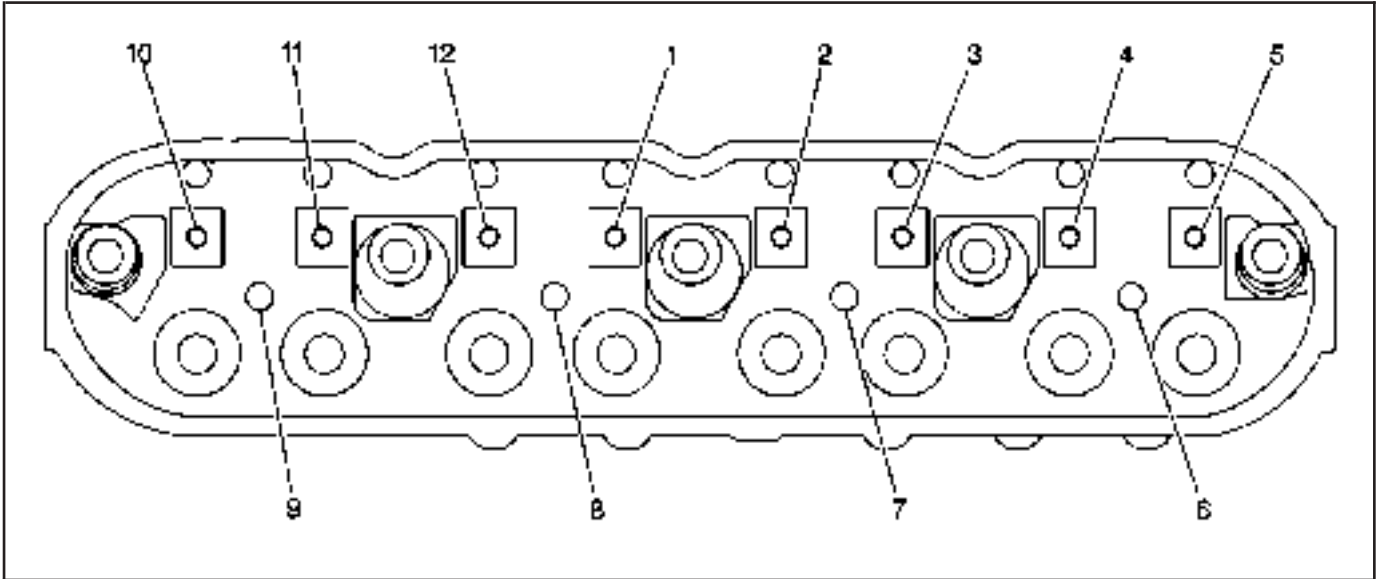


64573

Engine Block-Top View

Hole	Thread Size	Insert	Drill	Counterbore Tool	Tap	Driver	Drill Depth (Maximum) mm (in)	Tap Depth (Maximum) mm (in)
1-4	M8 x 1.25	J 42385-210	J 42385-206	J 42385-207	J 42385-208	J 42385-209	26.5 (1.04)	19.0 (0.784)
5	M16 x 1.5	—	—	—	—	—	—	—
6-7	M8 x 1.25	J 42385-210	J 42385-206	J 42385-207	J 42385-208	J 42385-209	26.5 (1.04)	19.0 (0.784)
8	M10 x 1.5	J 42385-216	J 42385-211	J 42385-212	J 42385-213	J 42385-214	22.5 (0.885)	17.0 (0.669)
9-10	M8 x 1.25	J 42385-210	J 42385-206	J 42385-207	J 42385-208	J 42385-209	26.5 (1.04)	19.0 (0.784)
11	M10 x 1.5	J 42385-216	J 42385-211	J 42385-212	J 42385-213	J 42385-214	22.5 (0.885)	17.0 (0.669)
12-14	M8 x 1.25	J 42385-210	J 42385-206	J 42385-207	J 42385-208	J 42385-209	26.5 (1.04)	19.0 (0.784)

Cylinder Head-Top View

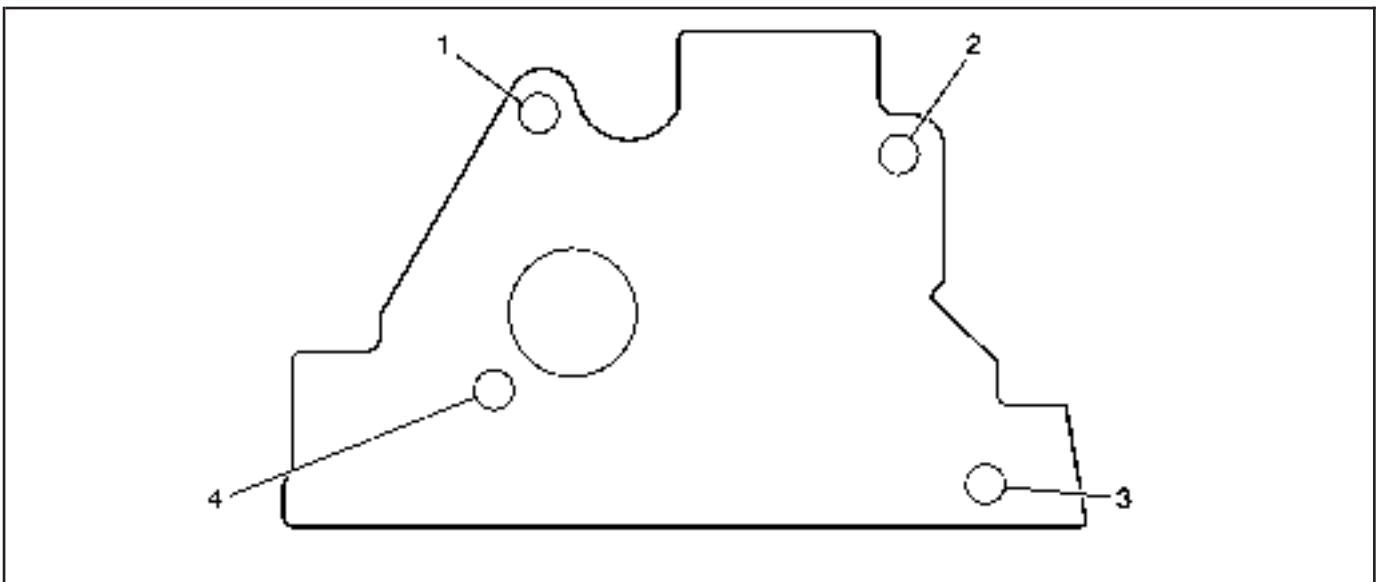


260168

Cylinder Head-Top View

Hole	Thread Size	Insert	Drill	Counterbore Tool	Tap	Driver	Drill Depth (Maximum) mm (in)	Tap Depth (Maximum) mm (in)
1-5	M8 x 1.25	J 42385-210	J 42385-206	J 42385-207	J 42385-208	J 42385-209	26.5 (1.04)	19.0 (0.784)
6-9	M6 x 1.0	J 42385-205	J 42385-201	J 42385-202	J 42385-203	J 42385-204	20.05 (0.789)	16.05 (0.632)
10-12	M8 x 1.25	J 42385-210	J 42385-206	J 42385-207	J 42385-208	J 42385-209	26.5 (1.04)	19.0 (0.784)

Cylinder Head-End View

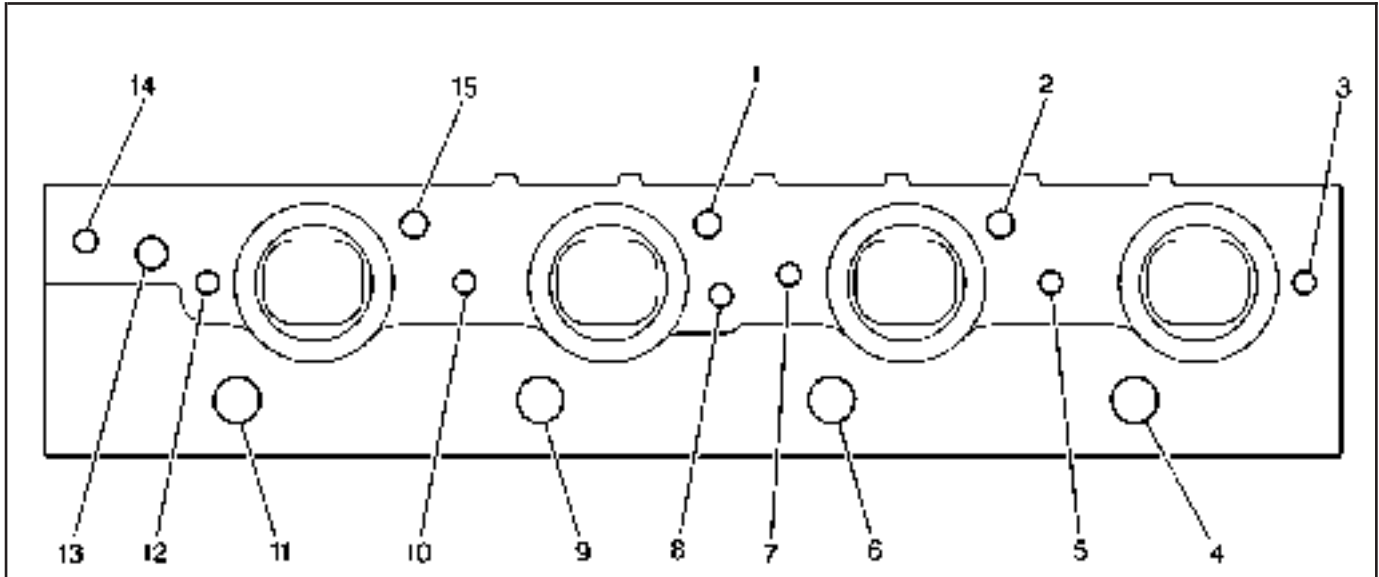


741550

Cylinder Head-End View

Hole	Thread Size	Insert	Drill	Counterbore Tool	Tap	Driver	Drill Depth (Maximum) mm (in)	Tap Depth (Maximum) mm (in)
1	M10 x 1.5	J 42385-215	J 42385-211	J 42385-212	J 42385-213	J 42385-214	28.0 (1.10)	20.0 (0.787)
2	M10 x 1.5	J 42385-215	J 42385-211	J 42385-212	J 42385-213	J 42385-214	28.0 (1.10)	20.0 (0.787)
3-4	M10 x 1.5	J 42385-215	J 42385-211	J 42385-212	J 42385-213	J 42385-214	28.0 (1.10)	20.0 (0.787)

Cylinder Head-Exhaust Manifold Deck View



64555

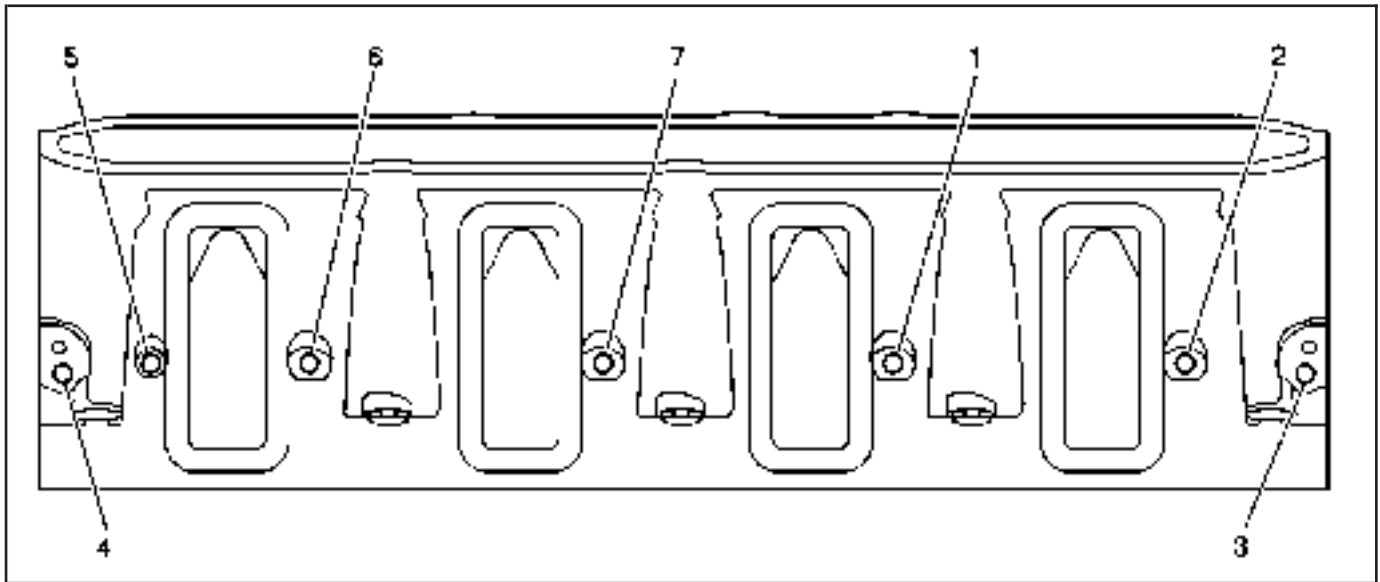
Cylinder Head-Exhaust Manifold Deck View

Hole	Thread Size	Insert	Drill	Counterbore Tool	Tap	Driver	Drill Depth (Maximum) mm (in)	Tap Depth (Maximum) mm (in)
1-2	M10 x 1.5	J 42385-215	J 42385-211	J 42385-212	J 42385-213	J 42385-214	28.0 (1.10)	20.0 (0.787)
3	M8 x 1.25	J 42385-210	J 42385-206	J 42385-207	J 42385-208	J 42385-209	21.0 (0.826)	16.0 (0.629)
4	M14 x 1.25	—	—	—	—	—	—	—
5	M8 x 1.25	J 42385-210	J 42385-206	J 42385-207	J 42385-208	J 42385-209	21.0 (0.826)	16.0 (0.629)
6	M14 x 1.25	—	—	—	—	—	—	—
7-8	M8 x 1.25	J 42385-210	J 42385-206	J 42385-207	J 42385-208	J 42385-209	21.0 (0.826)	16.0 (0.629)
9	M14 x 1.25	—	—	—	—	—	—	—
10	M8 x 1.25	J 42385-210	J 42385-206	J 42385-207	J 42385-208	J 42385-209	21.0 (0.826)	16.0 (0.629)
11	M14 x 1.25	—	—	—	—	—	—	—
12	M8 x 1.25	J 42385-210	J 42385-206	J 42385-207	J 42385-208	J 42385-209	21.0 (0.826)	16.0 (0.629)
13	M12 x 1.5	—	—	—	—	—	—	—

Cylinder Head-Exhaust Manifold Deck View (cont'd)

Hole	Thread Size	Insert	Drill	Counterbore Tool	Tap	Driver	Drill Depth (Maximum) mm (in)	Tap Depth (Maximum) mm (in)
14-15	M10 x 1.5	J 42385-215	J 42385-211	J 42385-212	J 42385-213	J 42385-214	28.0 (1.10)	20.0 (0.787)

Cylinder Head-Intake Manifold Deck View



260169

Cylinder Head-Intake Manifold Deck View

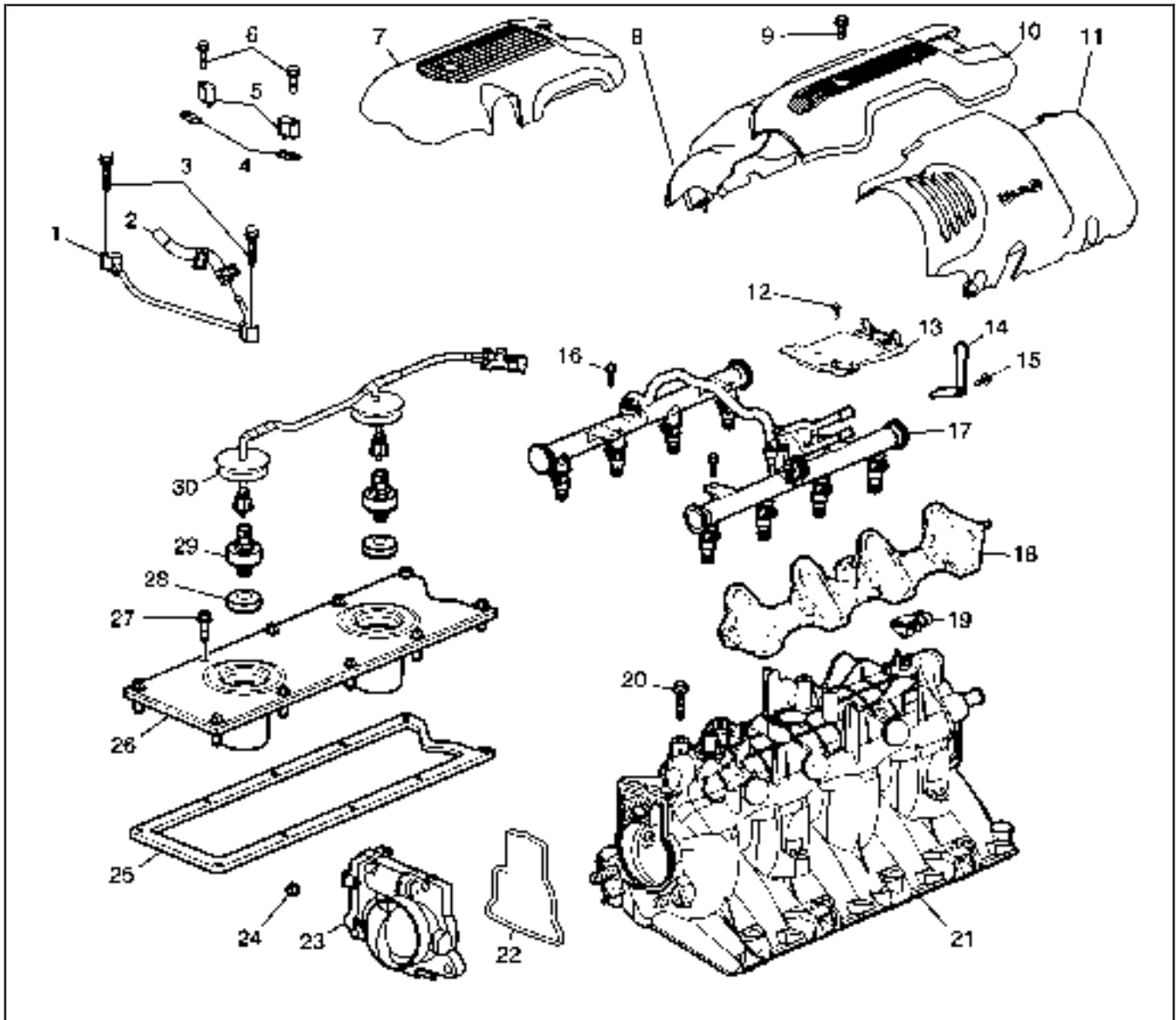
Hole 5	Thread Size	Insert	Drill	Counterbore Tool	Tap	Driver	Drill Depth (Maximum) mm (in)	Tap Depth (Maximum) mm (in)
1-2	M6 x 1.0	J 42385-205	J 42385-201	J 42385-202	J 42385-203	J 42385-204	Thru	Thru
3-4	M6 x 1.0	J 42385-205	J 42385-201	J 42385-202	J 42385-203	J 42385-204	22.5 (0.885)	15.0 (0.688)
5-7	M6 x 1.0	J 42385-205	J 42385-201	J 42385-202	J 42385-203	J 42385-204	Thru	Thru

Component Locator

Disassembled Views

SIE-ID = 825969 LMD = 18-mar-2002

Intake Manifold/Upper Engine SIO-ID = 869571 LMD = 25-mar-2002



869515

Legend

- | | |
|--|--|
| (1) Engine Coolant Air Bleed Pipe | (12) Engine Sight Shield Bracket Bolt |
| (2) Engine Coolant Air Bleed Pipe Hose | (13) Engine Sight Shield Bracket |
| (3) Engine Coolant Air Bleed Pipe Bolt | (14) Fuel Rail Stop Bracket |
| (4) Engine Coolant Air Bleed Pipe/Cover Gasket | (15) Fuel Rail Stop Bracket Bolt |
| (5) Engine Coolant Air Bleed Pipe Cover | (16) Fuel Rail Bolt |
| (6) Engine Coolant Air Bleed Pipe/Cover Bolt | (17) Fuel Rail – with Injectors |
| (7) Engine Sight Shield – 4.8/5.3L | (18) Intake Manifold Gasket |
| (8) Engine Sight Shield – Right Side 6.0L | (19) Manifold Absolute Pressure (MAP) Sensor |
| (9) Engine Sight Shield Bolt | (20) Intake Manifold Bolt |
| (10) Engine Sight Shield – Center 6.0L | (21) Intake Manifold |
| (11) Engine Sight Shield – Left Side 6.0L | (22) Throttle Body Gasket |

Engine**Engine Mechanical - 4.8L, 5.3L, and 6.0L 6-31**

(23) Throttle Body

(24) Throttle Body Nut

(25) Valley Cover Gasket

(26) Valley Cover

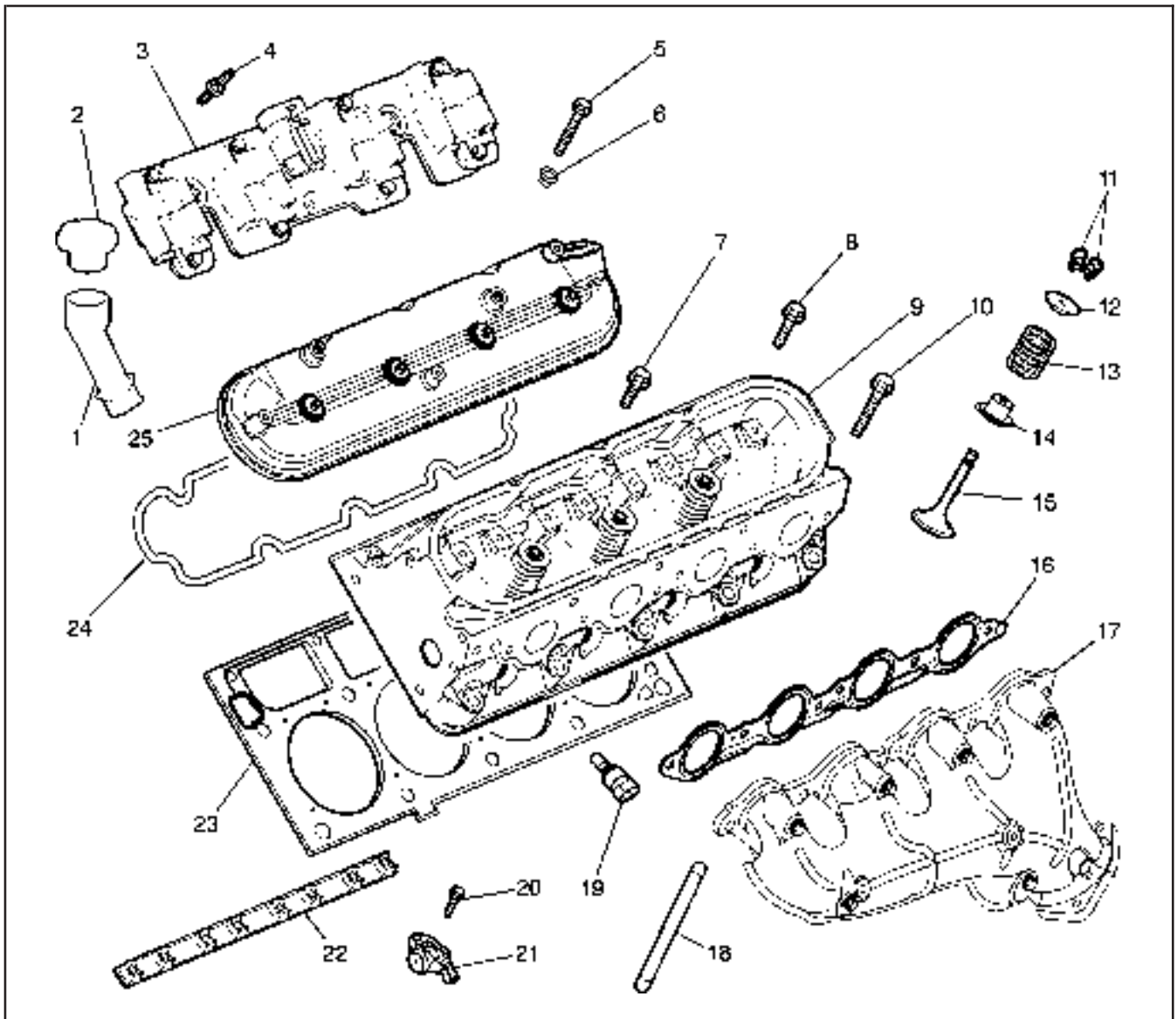
(27) Valley Cover Bolt

(28) Knock Sensor Oil Seal

(29) Knock Sensor

(30) Knock Sensor Wire Harness

Cylinder Head/Upper Engine SIO-ID = 823400 LMD = 02-oct-2001



823310

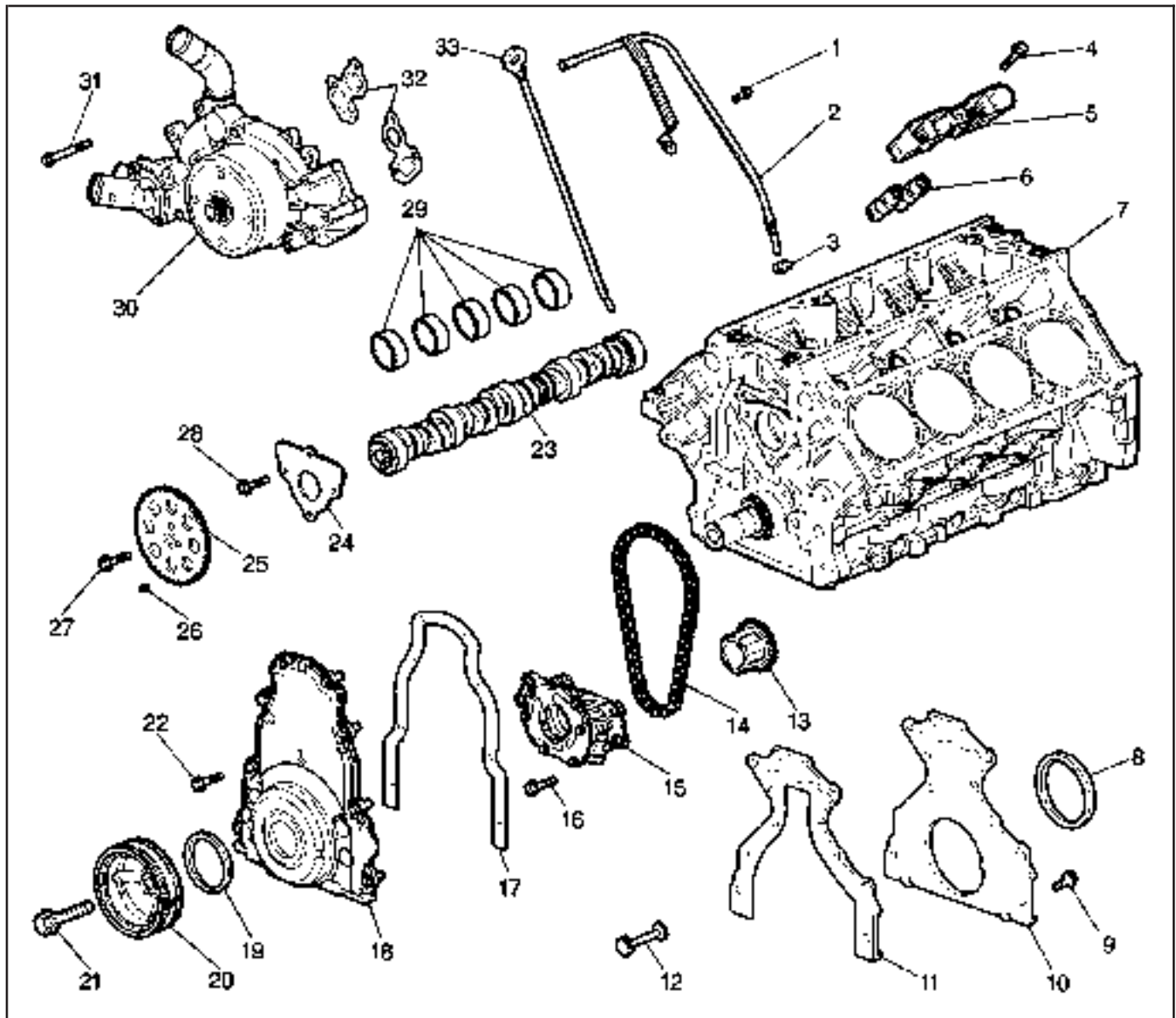
Legend

- | | |
|---|--|
| (1) Oil Fill Tube | (14) Valve Stem Oil Seal and Shim Assembly |
| (2) Oil Fill Tube Cap | (15) Valve |
| (3) Ignition Coil and Bracket Assembly | (16) Exhaust Manifold Gasket |
| (4) Ignition Coil and Bracket Assembly Bolt | (17) Exhaust Manifold – with Heat Shield |
| (5) Valve Rocker Arm Cover Bolt | (18) Pushrod |
| (6) Valve Rocker Arm Cover Bolt Grommet | (19) Coolant Temperature Sensor |
| (7) Cylinder Head Bolt – Short | (20) Valve Rocker Arm Bolt |
| (8) Cylinder Head Bolt – Medium | (21) Valve Rocker Arm |
| (9) Cylinder Head | (22) Valve Rocker Arm Pivot Support |
| (10) Cylinder Head Bolt – Long | (23) Cylinder Head Gasket |
| (11) Valve Stem Keys | (24) Valve Rocker Arm Cover Gasket |
| (12) Valve Spring Cap | (25) Valve Rocker Arm Cover |
| (13) Valve Spring | |

Lower Front of Engine

SIO-ID = 279693

LMD = 09-mar-1998



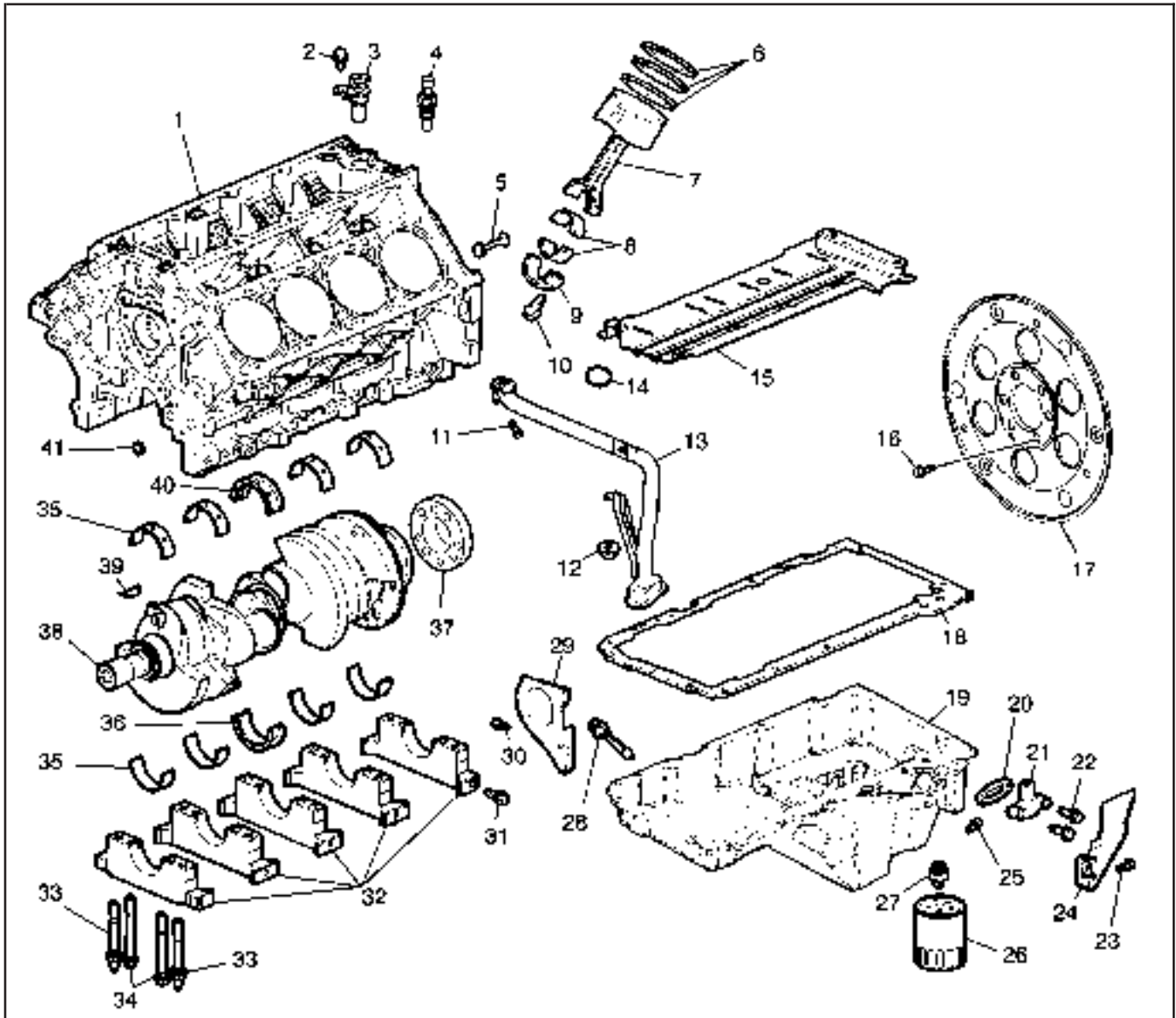
260163

Legend

- | | |
|--|-------------------------------------|
| (1) Oil Level Indicator Tube Bolt | (17) Engine Front Cover Gasket |
| (2) Oil Level Indicator Tube | (18) Engine Front Cover |
| (3) Oil Level Indicator Tube O-Ring Seal | (19) Crankshaft Front Oil Seal |
| (4) Valve Lifter Guide Bolt | (20) Crankshaft Balancer |
| (5) Valve Lifter Guide | (21) Crankshaft Balancer Bolt |
| (6) Valve Lifter | (22) Engine Front Cover Bolt |
| (7) Engine Block | (23) Camshaft |
| (8) Crankshaft Rear Oil Seal | (24) Camshaft Retainer |
| (9) Engine Rear Cover Bolt | (25) Camshaft Sprocket |
| (10) Engine Rear Cover | (26) Camshaft Sprocket Locating Pin |
| (11) Engine Rear Cover Gasket | (27) Camshaft Sprocket Bolt |
| (12) Engine Block Rear Oil Gallery Plug | (28) Camshaft Retainer Bolt |
| (13) Crankshaft Sprocket | (29) Camshaft Bearings |
| (14) Camshaft Timing Chain | (30) Water Pump |
| (15) Oil Pump Assembly | (31) Water Pump Bolt |
| (16) Oil Pump Bolt | (32) Water Pump Gaskets |

(33) Oil Level Indicator

Lower Engine Assembly SIO-ID = 825968 LMD = 19-apr-2002



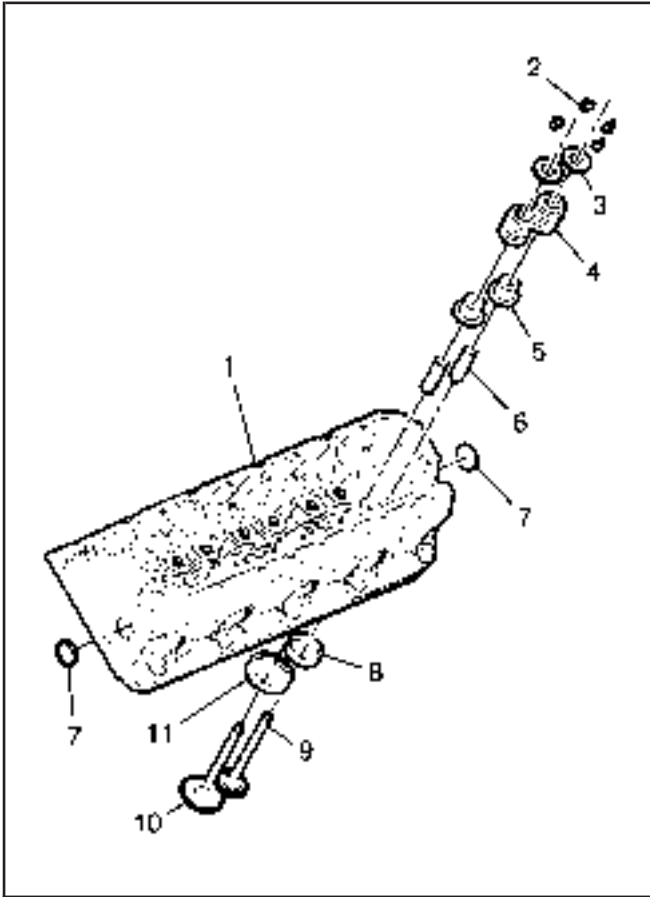
824385

Legend

- | | |
|--|---|
| (1) Engine Block | (17) Flywheel |
| (2) Camshaft Position Sensor Bolt | (18) Oil Pan Gasket |
| (3) Camshaft Position Sensor | (19) Oil Pan |
| (4) Oil Pressure Sensor | (20) Oil Pan Cover Gasket |
| (5) Engine Block Rear Oil Gallery Plug | (21) Oil Pan Cover |
| (6) Piston Rings | (22) Oil Pan Cover Bolt |
| (7) Piston and Connecting Rod Assembly | (23) Oil Pan Closeout Cover Bolt – Left Side |
| (8) Connecting Rod Bearings | (24) Oil Pan Closeout Cover – Left Side |
| (9) Connecting Rod Cap | (25) Oil Pan Drain Plug |
| (10) Connecting Rod Bolt | (26) Oil Filter |
| (11) Oil Pump Screen Bolt | (27) Oil Filter Adapter |
| (12) Oil Pump Screen Nut | (28) Oil Level Sensor |
| (13) Oil Pump Screen | (29) Oil Pan Closeout Cover – Right Side |
| (14) Oil Pump Screen O-ring Seal | (30) Oil Pan Closeout Cover Bolt – Right Side |
| (15) Crankshaft Oil Deflector | (31) Crankshaft Bearing Cap Side Bolt |
| (16) Flywheel Bolt | (32) Crankshaft Bearing Caps |

-
- | | |
|--|--|
| (33) Crankshaft Bearing Cap Bolt/Stud | (38) Crankshaft |
| (34) Crankshaft Bearing Cap Bolt | (39) Crankshaft Sprocket Key |
| (35) Crankshaft Bearing | (40) Crankshaft Thrust Bearing – Upper |
| (36) Crankshaft Thrust Bearing – Lower | (41) Engine Block Front Oil Gallery Plug |
| (37) Spacer | |
-

Cylinder Head Assembly – Aluminum SIO-ID = 822904 LMD = 05-oct-2001

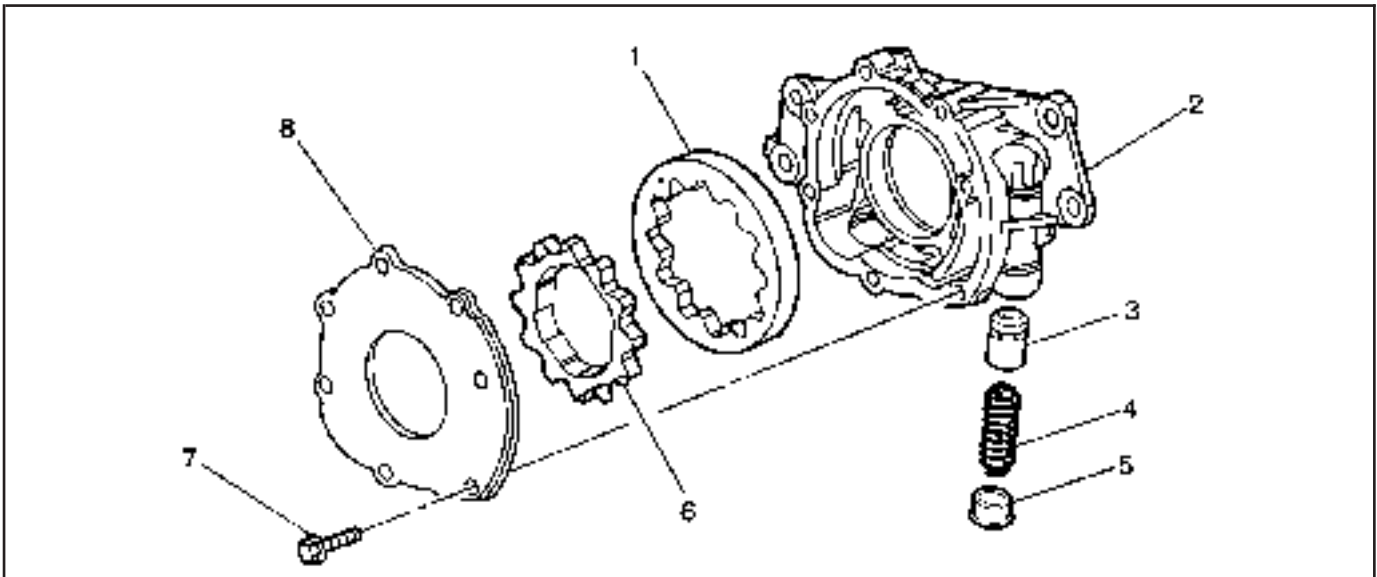


822537

Legend

- (1) Cylinder Head
- (2) Valve Stem Keys
- (3) Valve Spring Cap
- (4) Valve Spring
- (5) Valve Stem Oil Seal and Shim Assembly
- (6) Valve Guide
- (7) Cylinder Head Expansion Plugs
- (8) Exhaust Valve Seat
- (9) Exhaust Valve
- (10) Intake Valve
- (11) Intake Valve Seat

Oil Pump Assembly SIO-ID = 101820 LMD = 13-aug-1996



64190

Legend

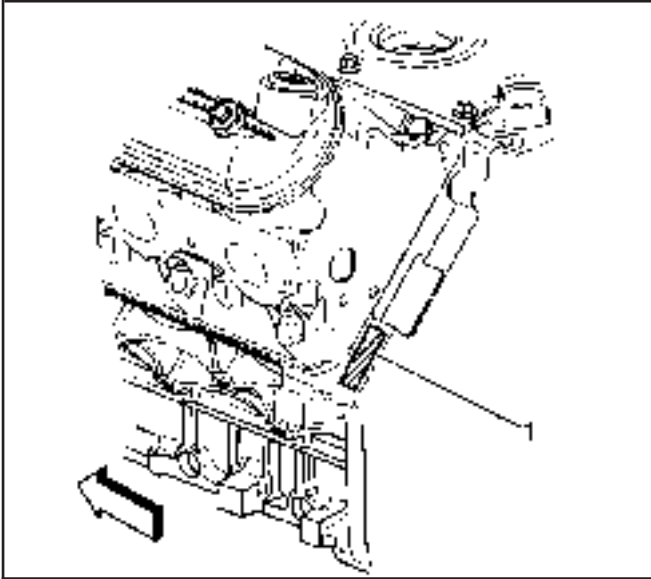
- (1) Driven Gear
- (2) Oil Pump Housing
- (3) Pressure Relief Valve
- (4) Pressure Relief Valve Spring
- (5) Plug
- (6) Drive Gear

(7) Cover Bolt

(8) Cover

Engine Identification

SIE-ID = 768218 LMD = 18-mar-2002



260136

The vehicle identification number (VIN) is located on the left side rear of the engine block (1) and is typically a nine digit number stamped or laser-etched onto the engine at the vehicle assembly plant.

- The first digit identifies the division.
- The second digit identifies the model year.
- The third digit identifies the assembly plant.
- The fourth through ninth digits are the last six digits of the VIN.

Diagnostic Information and Procedures

Diagnostic Starting Point - Engine Mechanical

SIE-ID = 823800 LMD = 03-oct-2001

Begin the system diagnosis by reviewing the *Disassembled Views, Engine Component Description, Lubrication Description, New Product Information, and Drive Belt System Description*. Reviewing the description and operation information will help you determine the correct symptom diagnostic procedure when a malfunction exists. Reviewing the description and operation information will also help you determine if the condition described by the customer is normal operation. Refer to *Symptoms - Engine Mechanical* in order to identify the correct procedure for diagnosing the system and where the procedure is located.

Symptoms - Engine Mechanical

SIE-ID = 823803 LMD = 04-apr-2002

Strategy Based Diagnostics

1. Perform the *Diagnostic System Check - Engine Controls* in Engine Controls – 4.8L, 5.3L, and 6.0L before using the symptom tables, if applicable.
2. Review the system operations in order to familiarize yourself with the system functions. Refer to *Disassembled Views, Engine Component Description, Lubrication Description, New Product Information, and Drive Belt System Description*.

All diagnosis on a vehicle should follow a logical process. Strategy based diagnostics is a uniform approach for repairing all systems. The diagnostic flow may always be used in order to resolve a system condition. The diagnostic flow is the place to start when repairs are necessary. For a detailed explanation, refer to *Strategy Based Diagnosis* in General Information.

Visual/Physical Inspection

- Inspect for aftermarket devices which could affect the operation of the Engine. Refer to *Checking Aftermarket Accessories* in Wiring Systems.
- Inspect the easily accessible or visible system components for obvious damage or conditions which could cause the symptom.
- Check for the correct oil level, proper oil viscosity, and correct filter application.

- Verify the exact operating conditions under which the concern exists. Note factors such as engine RPM, ambient temperature, engine temperature, amount of engine warm-up time, and other specifics.
- Compare the engine sounds, if applicable, to a known good engine and make sure you are not trying to correct a normal condition.

Intermittent

Test the vehicle under the same conditions that the customer reported in order to verify the system is operating properly.

Symptom List

Refer to a symptom diagnostic procedure from the following list in order to diagnose the symptom:

- *Base Engine Misfire without Internal Engine Noises*
- *Base Engine Misfire with Abnormal Internal Lower Engine Noises*
- *Base Engine Misfire with Abnormal Valve Train Noise*
- *Base Engine Misfire with Coolant Consumption*
- *Base Engine Misfire with Excessive Oil Consumption*
- *Engine Compression Test*
- *Engine Noise on Start-Up, but Only Lasting a Few Seconds*
- *Upper Engine Noise, Regardless of Engine Speed*
- *Lower Engine Noise, Regardless of Engine Speed*
- *Engine Noise Under Load*
- *Engine Will Not Crank - Crankshaft Will Not Rotate*
- *Coolant in Combustion Chamber*
- *Coolant in Engine Oil*
- *Oil Consumption Diagnosis*
- *Oil Pressure Diagnosis and Testing*
- *Oil Leak Diagnosis*
- *Cylinder Leakage Test*
- *Drive Belt Chirping Diagnosis*
- *Drive Belt Squeal Diagnosis*
- *Drive Belt Whine Diagnosis*
- *Drive Belt Rumbling Diagnosis*
- *Drive Belt Vibration Diagnosis*
- *Drive Belt Falls Off Diagnosis*
- *Drive Belt Excessive Wear Diagnosis*
- *Drive Belt Tensioner Diagnosis*

SIE-ID = 863420 LMD = 26-feb-2002

Base Engine Misfire without Internal Engine Noises

Cause	Correction
<p>Abnormalities, such as severe cracking, bumps, or missing areas in the accessory drive belt</p> <p>Abnormalities in the accessory drive system and/or components may cause engine RPM variations and lead to a misfire DTC. A misfire code may be present without an actual misfire condition.</p>	<p>Replace the drive belt. Refer to <i>Drive Belt Replacement - Accessory</i>.</p>
<p>Worn, damaged, or mis-aligned accessory drive components or excessive pulley runout and may lead to a misfire DTC.</p> <p>A misfire code may be present without an actual misfire condition.</p>	<p>Inspect the components, and repair or replace as required.</p>
<p>Loose or improperly installed engine flywheel or crankshaft balancer</p> <p>A misfire code may be present without an actual misfire condition.</p>	<p>Repair or replace the flywheel and/or balancer as required. Refer to <i>Engine Flywheel Replacement</i> or <i>Crankshaft Balancer Replacement</i>.</p>
<p>Restricted exhaust system</p> <p>A severe restriction in the exhaust flow can cause significant loss of engine performance and may set a DTC. Possible causes of restrictions include collapsed or dented pipes or plugged mufflers and/or catalytic converters.</p>	<p>Repair or replace as required.</p>
<p>Improperly installed or damaged vacuum hoses</p>	<p>Repair or replace as required.</p>
<p>Improper sealing between the intake manifold and cylinder heads or throttle body.</p>	<p>Replace the intake manifold, gaskets, cylinder heads, and/or throttle body as required.</p>
<p>Improperly installed or damaged MAP sensor</p> <p>The sealing grommet of the MAP sensor should not be torn or damaged.</p>	<p>Repair or replace the MAP sensor as required.</p>
<p>Worn or loose rocker arms</p> <p>The rocker arm bearing end caps and/or needle bearings should be intact and in the proper position.</p>	<p>Replace the valve rocker arms as required.</p>
<p>Worn or bent pushrods</p>	<ul style="list-style-type: none"> • Replace the pushrods. • Inspect the top of the pistons for valve contact. If the top of the piston shows valve contact, replace the piston and pin assembly.
<p>Stuck valves</p> <p>Carbon buildup on the valve stem can cause the valve not to close properly.</p>	<p>Repair or replace as required.</p>
<p>Excessively worn or mis-aligned timing chain</p>	<p>Replace the timing chain and sprockets as required.</p>
<p>Worn camshaft lobes</p>	<p>Replace the camshaft and valve lifters.</p>
<p>Excessive oil pressure</p> <p>A lubrication system with excessive oil pressure may lead to excessive valve lifter pump-up and loss of compression.</p>	<ul style="list-style-type: none"> • Perform an oil pressure test. Refer to <i>Oil Pressure Diagnosis and Testing</i>. • Repair or replace the oil pump as required.
<p>Faulty cylinder head gaskets and/or cracking or other damage to the cylinder heads and engine block cooling system passages. Refer to <i>Diagnostic Starting Point - Engine Cooling</i> in Engine Cooling.</p> <p>Coolant consumption may or may not cause the engine to overheat.</p>	<ul style="list-style-type: none"> • Inspect for spark plugs saturated by coolant. Refer to <i>Spark Plug Inspection</i> in Engine Controls – 4.8L, 5.3L, and 6.0L. • Inspect the cylinder heads, engine block, and/or head gaskets. Refer to <i>Coolant in Combustion Chamber</i>. • Repair or replace as required.
<p>Worn piston rings</p> <p>Oil consumption may or may not cause the engine to misfire.</p>	<ul style="list-style-type: none"> • Inspect the spark plugs for oil deposits. Refer to <i>Spark Plug Inspection</i> in Engine Controls – 4.8L, 5.3L, and 6.0L. • Inspect the cylinders for a loss of compression. Refer to <i>Engine Compression Test</i>. • Perform cylinder leak down and compression testing to identify the cause. Refer to <i>Cylinder Leakage Test</i>. • Repair or replace as required.

Base Engine Misfire without Internal Engine Noises (cont'd)

Cause	Correction
<p>A damaged crankshaft reluctor wheel</p> <p>A damaged crankshaft reluctor wheel can result in different symptoms depending on the severity and location of the damage.</p> <ul style="list-style-type: none"> Systems with electronic communications, DIS or coil per cylinder, and severe reluctor ring damage may exhibit periodic loss of crankshaft position, stop delivering a signal, and then sync the crankshaft position. Systems with electronic communication, DIS or coil per cylinder, and slight reluctor ring damage may exhibit no loss of crankshaft position and no misfire may occur. However, a P0300 DTC may be set. Systems with mechanical communications, high voltage switch, and severe reluctor ring damage may cause additional pulses and effect fuel and spark delivery to the point of generating a P0300 DTC or P0336. 	<p>Replace the sensor and/or crankshaft as required.</p>

SIE-ID = 863423 LMD = 26-feb-2002

Base Engine Misfire with Abnormal Internal Lower Engine Noises

Cause	Correction
<p>Abnormalities, such as severe cracking, bumps or missing areas in the accessory drive belt</p> <p>Abnormalities in the accessory drive system and/or components may cause engine RPM variations, noises similar to a faulty lower engine and also lead to a misfire condition. A misfire code may be present without an actual misfire condition.</p>	<p>Replace the drive belt. Refer to <i>Drive Belt Replacement - Accessory</i>.</p>
<p>Worn, damaged, or mis-aligned accessory drive components or excessive pulley runout</p> <p>A misfire code may be present without an actual misfire condition.</p>	<p>Inspect the components, repair or replace as required.</p>
<p>Loose or improperly installed engine flywheel or crankshaft balancer</p> <p>A misfire code may be present without an actual misfire condition.</p>	<p>Repair or replace the flywheel and/or balancer as required. Refer to <i>Engine Flywheel Replacement</i> or <i>Crankshaft Balancer Replacement</i>.</p>
<p>Worn piston rings</p> <p>Oil consumption may or may not cause the engine to misfire.</p>	<ul style="list-style-type: none"> Inspect the spark plugs for oil deposits. Refer to <i>Spark Plug Inspection</i> in Engine Controls – 4.8L, 5.3L, and 6.0L. Inspect the cylinders for a loss of compression. Refer to <i>Engine Compression Test</i>. Perform cylinder leak down and compression testing to determine the cause. Refer to <i>Cylinder Leakage Test</i>. Repair or replace as required.
<p>Worn crankshaft thrust bearings</p> <p>Severely worn thrust surfaces on the crankshaft and/or thrust bearing may permit fore and aft movement of the crankshaft and create a DTC without an actual misfire condition.</p>	<p>Replace the crankshaft and bearings as required.</p>

SIE-ID = 643952 LMD = 02-oct-2001

Base Engine Misfire with Abnormal Valve Train Noise

Cause	Correction
<p>Worn or loose rocker arms</p> <p>The rocker arm bearing end caps and/or needle bearings should be intact within the rocker arm assembly.</p>	<p>Replace the valve rocker arms as required.</p>
<p>Worn or bent pushrods</p>	<ul style="list-style-type: none"> Replace the pushrods. Inspect the top of the pistons for valve contact. If the top of the piston shows valve contact, replace the piston and pin assembly.

Base Engine Misfire with Abnormal Valve Train Noise (cont'd)

Cause	Correction
Stuck valves Carbon buildup on the valve stem can cause the valve not to close properly.	Repair or replace as required.
Excessively worn or mis-aligned timing chain	Replace the timing chain and sprockets as required.
Worn camshaft lobes	Replace the camshaft and valve lifters.
Sticking lifters	Replace as required.

SIE-ID = 863424 LMD = 26-feb-2002

Base Engine Misfire with Coolant Consumption

Cause	Correction
Faulty cylinder head gaskets and/or cracking or other damage to the cylinder heads and engine block cooling system passages. Refer to <i>Diagnostic Starting Point - Engine Cooling</i> in Engine Cooling. Coolant consumption may or may not cause the engine to overheat.	<ul style="list-style-type: none"> Inspect for spark plugs saturated by coolant. Refer to <i>Spark Plug Inspection</i> in Engine Controls – 4.8L, 5.3L, and 6.0L. Perform a cylinder leak down test. Refer to <i>Cylinder Leakage Test</i>. Inspect the cylinder heads and engine block for damage to the coolant passages and/or a faulty head gasket. Refer to <i>Coolant in Combustion Chamber</i>. Repair or replace as required.

SIE-ID = 863427 LMD = 26-feb-2002

Base Engine Misfire with Excessive Oil Consumption

Cause	Correction
Worn valves, valve guides and/or valve stem oil seals	<ul style="list-style-type: none"> Inspect the spark plugs for oil deposits. Refer to <i>Spark Plug Inspection</i> in Engine Controls – 4.8L, 5.3L, and 6.0L. Repair or replace as required.
Worn piston rings Oil consumption may or may not cause the engine to misfire.	<ul style="list-style-type: none"> Inspect the spark plugs for oil deposits. Refer to <i>Spark Plug Inspection</i> in Engine Controls – 4.8L, 5.3L, and 6.0L. Inspect the cylinders for a loss of compression. Refer to <i>Engine Compression Test</i>. Perform cylinder leak down and compression testing to determine the cause. Refer to <i>Cylinder Leakage Test</i>. Repair or replace as required.

SIE-ID = 643955 LMD = 02-oct-2001

Engine Noise on Start-Up, but Only Lasting a Few Seconds

Cause	Correction
<p>Important: A cold piston knock which disappears in 1.5 minutes should be considered acceptable. A cold engine knock usually disappears when the specific cylinder's secondary ignition circuit is grounded out during diagnosis. A light rattle/tapping noise may indicate a valve train, upper engine, concern, or a low rumble/knocking may indicate a crankshaft or piston, lower engine concern.</p>	
Incorrect oil filter without anti-drainback feature	Install the correct oil filter.
Incorrect oil viscosity	<ol style="list-style-type: none"> Drain the oil. Install the correct viscosity oil.
High valve lifter leak down rate	Replace the lifters as required.
Worn crankshaft thrust bearing	<ol style="list-style-type: none"> Check the crankshaft end play. Inspect the thrust bearing and crankshaft. Repair or replace as required.
Damaged or faulty oil filter by-pass valve	<ul style="list-style-type: none"> Inspect the oil filter by-pass valve for proper operation. Repair or replace as required.

SIE-ID = 643956 LMD = 02-oct-2001

Upper Engine Noise, Regardless of Engine Speed

Cause	Correction
<p>Important: A cold piston knock which disappears in 1.5 minutes should be considered acceptable. A cold engine knock usually disappears when the specific cylinder's secondary ignition circuit is grounded out during diagnosis.</p> <p>A light rattle/tapping noise may indicate a valve train, upper engine concern.</p> <p>During certain conditions, the evaporative emission solenoid and the fuel injectors may also create a sound similar to valve train noise.</p>	
Low oil pressure	<ul style="list-style-type: none"> Perform an oil pressure test. Refer to <i>Oil Pressure Diagnosis and Testing</i>. Repair or replace as required.
Loose and/or worn valve rocker arm attachments	<ul style="list-style-type: none"> Inspect the valve rocker arm, bolt, and pedestal. Repair or replace as required.
Worn or damaged valve rocker arm	<ul style="list-style-type: none"> Inspect the rocker arm for wear or missing needle bearings Replace the valve rocker arms as required.
Bent or damaged push rod	<p>Inspect the following components and replace as required:</p> <ul style="list-style-type: none"> The valve rocker arm The valve push rod The valve lifter The valve lifter guide The piston <p>Inspect the top of the pistons for valve contact. If the top of the piston shows valve contact, replace the piston and pin assembly.</p>
Improper lubrication to the valve rocker arms	<p>Inspect the following components and repair or replace as required:</p> <ul style="list-style-type: none"> The valve rocker arm The valve push rod The valve lifter The oil filter bypass valve The oil pump and pump screen The engine block oil galleries
Broken valve spring	Replace the valve spring and spring shim.
Worn or dirty valve lifters	Replace the valve lifters.
Stretched or broken timing chain and/or damaged sprocket teeth	Replace the timing chain and sprockets.
Worn engine camshaft lobes	<ul style="list-style-type: none"> Inspect the engine camshaft lobes. Replace the camshaft and valve lifters as required.
Worn valve guides or valve stems	<p>Inspect the following components and repair as required:</p> <ul style="list-style-type: none"> The valves The valve guides
Stuck valves Carbon on the valve stem or valve seat may cause the valve to stay open.	<p>Inspect the following components and repair as required:</p> <ul style="list-style-type: none"> The valves The valve guides

SIE-ID = 751578 LMD = 26-feb-2002

Lower Engine Noise, Regardless of Engine Speed

Cause	Correction
<p>Important: A cold piston knock which disappears in 1.5 minutes should be considered acceptable. A cold engine knock usually disappears when the specific cylinder's secondary ignition circuit is grounded out during diagnosis.</p> <p>A low rumble/knocking may indicate a crankshaft or piston, lower engine, concern.</p>	
Low oil pressure	<ul style="list-style-type: none"> Perform an oil pressure test. Refer to <i>Oil Pressure Diagnosis and Testing</i>. Repair or replace damaged components as required.

Lower Engine Noise, Regardless of Engine Speed (cont'd)

Cause	Correction
Worn accessory drive components Abnormalities such as severe cracking, bumps or missing areas in the accessory drive belt and/or misalignment of system components.	<ul style="list-style-type: none"> Inspect the accessory drive system. Repair or replace as required.
Loose or damaged crankshaft balancer	<ul style="list-style-type: none"> Inspect the crankshaft balancer. Repair or replace as required.
Detonation or spark knock	Verify the correct operation of the ignition controls system. Refer to <i>Detonation/Spark Knock</i> in Engine Controls – 4.8L, 5.3L, and 6.0L.
Loose torque converter bolts	<ul style="list-style-type: none"> Inspect the torque converter bolts and flywheel. Repair or replace as required.
Loose or damaged flywheel	Repair or replace the flywheel.
Oil pump screen loose, damaged or restricted	<ul style="list-style-type: none"> Inspect the oil pump screen. Repair or replace as required.
Excessive piston-to-cylinder bore clearance	<ul style="list-style-type: none"> Inspect the piston and cylinder bore. Repair as required.
Excessive piston pin-to-bore clearance	<ul style="list-style-type: none"> Inspect the piston, piston pin, and the connecting rod. Repair or replace as required.
Excessive connecting rod bearing clearance	Inspect the following components, and repair as required: <ul style="list-style-type: none"> The connecting rod bearings The connecting rods The crankshaft The crankshaft journals
Excessive crankshaft bearing clearance	Inspect the following components, and repair as required: <ul style="list-style-type: none"> The crankshaft bearings The crankshaft journals
Incorrect piston, piston pin and connecting rod installation Pistons must be installed with the mark or dimple on the top of the piston facing the front of the engine. Piston pins must be centered in the connecting rod pin bore.	<ul style="list-style-type: none"> Verify the pistons, piston pins and connecting rods are installed correctly. Refer to <i>Piston, Connecting Rod, and Bearing Installation</i>. Repair as required.

SIE-ID = 643958 LMD = 26-feb-2002

Engine Noise Under Load

Cause	Correction
<p>Important: A cold piston knock which disappears in 1.5 minutes should be considered acceptable. A cold engine knock usually disappears when the specific cylinder's secondary ignition circuit is grounded out during diagnosis.</p> <p>A low rumble/knocking may indicate a crankshaft or piston, lower engine concern.</p>	
Low oil pressure	<ul style="list-style-type: none"> Perform an oil pressure test. Refer to <i>Oil Pressure Diagnosis and Testing</i>. Repair or replace as required.
Detonation or spark knock	Verify the correct operation of the ignition controls. Refer to <i>Detonation/Spark Knock</i> in Engine Controls – 4.8L, 5.3L, and 6.0L.
Loose torque converter bolts	<ul style="list-style-type: none"> Inspect the torque converter bolts and flywheel. Repair as required.
Cracked flywheel – automatic transmission	<ul style="list-style-type: none"> Inspect the flywheel bolts and flywheel. Repair as required.
Excessive connecting rod bearing clearance	Inspect the following components, and repair as required: <ul style="list-style-type: none"> The connecting rod bearings The connecting rods The crankshaft

Engine Noise Under Load (cont'd)

Cause	Correction
Excessive crankshaft bearing clearance	Inspect the following components, and repair as required: <ul style="list-style-type: none"> • The crankshaft bearings • The crankshaft journals • The cylinder block crankshaft bearing bore

SIE-ID = 863428 LMD = 26-feb-2002

Engine Will Not Crank - Crankshaft Will Not Rotate

Cause	Correction
Seized accessory drive system component	<ol style="list-style-type: none"> 1. Remove the accessory drive belts. 2. Confirm that the engine will rotate. Rotate the crankshaft by hand at the crankshaft balancer or flywheel location. 3. Repair or replace the components as required.
Seized automatic transmission torque converter	<ol style="list-style-type: none"> 1. Remove the torque converter-to-flywheel bolts. 2. Confirm that the engine will rotate. Rotate the crankshaft by hand at the crankshaft balancer or flywheel location. 3. Repair or replace the components as required.
Broken timing chain	<ul style="list-style-type: none"> • Inspect the timing chain and gears. • Repair or replace the components as required.
Seized timing chain or timing gears	<ul style="list-style-type: none"> • Inspect the timing chain and gears for foreign material or a seized chain. • Repair or replace the components as required.
Seized or broken camshaft	<ul style="list-style-type: none"> • Inspect the camshaft and the camshaft bearings. • Repair or replace the components as required.
Bent valve in the cylinder head	<ul style="list-style-type: none"> • Inspect the valves and the cylinder heads. • Repair or replace the components as required.
Seized oil pump	<ul style="list-style-type: none"> • Inspect the oil pump assembly. • Repair or replace as required.
Hydraulically locked cylinder <ul style="list-style-type: none"> • Coolant/antifreeze in the cylinder • Oil in the cylinder • Fuel in the cylinder 	<ol style="list-style-type: none"> 1. Remove spark plugs and check for fluid in the cylinder. When rotating the engine with the spark plugs removed, the piston, on compression stroke, will push fluid from the combustion chamber. Refer to <i>Coolant in Combustion Chamber</i>. 2. Inspect for failed/broken head gaskets. 3. Inspect for a cracked engine block or cylinder head. 4. Inspect for a sticking fuel injector. 5. Repair or replace the components as required.
Material in the cylinder <ul style="list-style-type: none"> • Broken valve • Broken piston rings • Piston material • Foreign material 	<ul style="list-style-type: none"> • Inspect the cylinder for damaged components and/or foreign materials. • Repair or replace the components as required.
Seized crankshaft or connecting rod bearings	<ul style="list-style-type: none"> • Inspect crankshaft and connecting rod bearings. • Repair or replace the components as required.
Bent or broken connecting rod	<ul style="list-style-type: none"> • Inspect the connecting rods. • Repair or replace the components as required.
Broken crankshaft	<ul style="list-style-type: none"> • Inspect the crankshaft. • Repair or replace the components as required.

SIE-ID = 825557 LMD = 18-mar-2002

Coolant in Combustion Chamber

Cause	Correction
<p>DEFINITION: Excessive white smoke and/or coolant type odor coming from the exhaust pipe may indicate coolant in the combustion chamber. Low coolant levels, an inoperative cooling fan, or a faulty thermostat may lead to an "overtemperature" condition which may cause engine component damage.</p> <ol style="list-style-type: none"> 1. A slower than normal cranking speed may indicate coolant entering the combustion chamber. Refer to <i>Engine Will Not Crank - Crankshaft Will Not Rotate</i>. 2. Remove the spark plugs and inspect for spark plugs saturated by coolant or coolant in the cylinder bore. 3. Inspect by performing a cylinder leak-down test. During this test, excessive air bubbles within the coolant may indicate a faulty gasket or damaged component. 4. Inspect by performing a cylinder compression test. Two cylinders "side-by-side" on the engine block, with low compression, may indicate a failed cylinder head gasket. Refer to <i>Engine Compression Test</i>. 	
Cracked intake manifold or failed gasket	Replace the components as required.
Faulty cylinder head gasket	Replace the head gasket and components as required. Refer to <i>Cylinder Head Cleaning and Inspection</i> and <i>Cylinder Head Replacement - Left</i> or <i>Cylinder Head Replacement - Right</i> .
Warped cylinder head	Machine the cylinder head to the proper flatness, if applicable and replace the cylinder head gasket. Refer to <i>Cylinder Head Cleaning and Inspection</i> .
Cracked cylinder head	Replace the cylinder head and gasket.
Cracked cylinder liner or engine block	Replace the components as required.
Cylinder head or engine block porosity	Replace the components as required.

SIE-ID = 825558 LMD = 18-mar-2002

Coolant in Engine Oil

Cause	Correction
<p>DEFINITION: Foamy or discolored oil or an engine oil "overfill" condition may indicate coolant entering the engine crankcase. Low coolant levels, an inoperative cooling fan, or a faulty thermostat may lead to an "overtemperature" condition which may cause engine component damage. Contaminated engine oil and oil filter should be changed.</p> <ol style="list-style-type: none"> 1. Inspect the oil for excessive foaming or an overfill condition. Oil diluted by coolant may not properly lubricate the crankshaft bearings and may lead to component damage. Refer to <i>Lower Engine Noise, Regardless of Engine Speed</i>. 2. Inspect by performing a cylinder leak-down test. During this test, excessive air bubbles within the cooling system may indicate a faulty gasket or damaged component. 3. Inspect by performing a cylinder compression test. Two cylinders "side-by-side" on the engine block with low compression may indicate a failed cylinder head gasket. Refer to <i>Engine Compression Test</i>. 	
Faulty external engine oil cooler	Replace the components as required.
Faulty cylinder head gasket	Replace the head gasket and components as required. Refer to <i>Cylinder Head Cleaning and Inspection</i> and <i>Cylinder Head Replacement - Left</i> or <i>Cylinder Head Replacement - Right</i> .
Warped cylinder head	Machine the cylinder head to proper flatness, if applicable, and replace the cylinder head gasket. Refer to <i>Cylinder Head Cleaning and Inspection</i> .
Cracked cylinder head	Replace the cylinder head and gasket.
Cracked cylinder liner or engine block	Replace the components as required.
Cylinder head, block, or manifold porosity	Replace the components as required.

Engine Compression Test

SIE-ID = 863430 LMD = 26-feb-2002

1. Charge the battery if the battery is not fully charged.
2. Disable the ignition system.
3. Disable the fuel injection system.
4. Remove all the spark plugs.
5. Turn the ignition to the ON position.
6. Depress the accelerator pedal to position the throttle plate wide open.
7. Start with the compression gauge at zero and crank the engine through four compression strokes, four puffs.
8. Check the compression for each cylinder. Record the readings.
9. If a cylinder has low compression, inject approximately 15 ml (1 tablespoon) of engine oil into the combustion chamber through the spark plug hole. Recheck the compression and record the reading.
10. The minimum compression in any one cylinder should not be less than 70 percent of the highest cylinder. No cylinder should read less than

690 kPa (100 psi). For example, if the highest pressure in any one cylinder is 1 035 kPa (150 psi), the lowest allowable pressure for any other cylinder would be 725 kPa (105 psi). (1 035 x 70% = 725) (150 x 70% = 105).

- Normal — Compression builds up quickly and evenly to the specified compression for each cylinder.
- Piston Rings Leaking — Compression is low on the first stroke. Then compression builds up with the following strokes but does not reach normal. Compression improves considerably when you add oil.
- Valves Leaking — Compression is low on the first stroke. Compression usually does not build up on the following strokes. Compression does not improve much when you add oil.
- If two adjacent cylinders have lower than normal compression, and injecting oil into the cylinders does not increase the compression, the cause may be a head gasket leaking between the cylinders.

Cylinder Leakage Test

SIE-ID = 863439 LMD = 26-feb-2002

Tools Required

J 35667-A Cylinder Head Leakdown Tester or equivalent

Important: A leakage test may be performed in order to measure cylinder/combustion chamber leakage. High cylinder leakage may indicate one or more of the following:

- Worn or burnt valves
- Broken valve springs
- Stuck valve lifters
- Incorrect valve lash
- Damaged piston
- Worn piston rings
- Worn or scored cylinder bore

- Damaged cylinder head gasket
- Cracked or damaged cylinder head
- Cracked or damaged engine block

Caution: Refer to Battery Disconnect Caution in Cautions and Notices.

1. Disconnect the battery ground negative cable.
2. Remove the spark plugs. Refer to *Spark Plug Replacement* in Engine Controls – 4.8L, 5.3L, and 6.0L.
3. Rotate the crankshaft to place the piston in the cylinder being tested at top dead center (TDC) of the compression stroke.
4. Install the J 35667-A or equivalent.

Important: It may be necessary to hold the crankshaft balancer bolt to prevent the crankshaft from rotating.

5. Apply shop air pressure to the J 35667-A and adjust according to the manufacturers instructions.
6. Record the cylinder leakage value. Cylinder leakage that exceeds 25 percent is considered excessive and may require component service. In excessive leakage situations, inspect for the following conditions:

- Air leakage noise at the throttle body or air inlet hose that may indicate a worn or burnt intake valve or a broken valve spring.
- Air leakage noise at the exhaust system tailpipe that may indicate a worn or burnt exhaust valve or a broken valve spring.
- Air leakage noise from the crankcase, oil level indicator tube, or oil fill tube that may indicate worn piston rings, a damaged piston, a worn or scored cylinder bore, a damaged engine block or a damaged cylinder head.
- Air bubbles in the cooling system may indicate a damaged cylinder head or a damaged cylinder head gasket.

7. Perform the leakage test on the remaining cylinders and record the values.

SIE-ID = 740685 LMD = 10-jun-2002

Oil Consumption Diagnosis

Checks	Causes
Excessive oil consumption, not due to leaks, is the use of 1 L (1 qt) or more of engine oil within 3,200 kilometers (2,000 miles).	

Oil Consumption Diagnosis (cont'd)

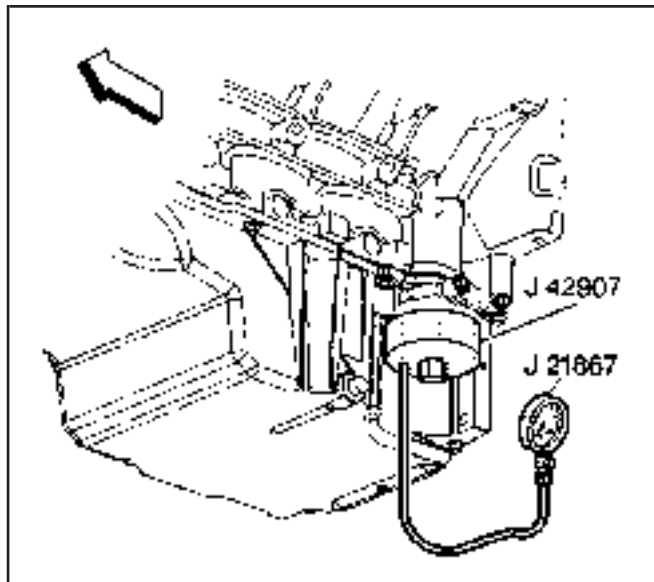
Checks	Causes
Preliminary	<p>The causes of excessive oil consumption may include the following conditions:</p> <ul style="list-style-type: none"> • External oil leaks Refer to <i>Oil Leak Diagnosis</i>. • Incorrect oil level or improper reading of the oil level indicator With the vehicle on a level surface, run the engine for a few minutes, allow adequate drain down time, 2–3 minutes, and check for the correct engine oil level. • Improper oil viscosity Refer to the vehicle owners manual and use the recommended SAE grade and viscosity for the prevailing temperatures. • Continuous high speed driving and/or severe usage • Crankcase ventilation system restrictions or malfunctioning components • Worn valve guides and/or valve stems • Worn or improperly installed valve stem oil seals • Piston rings broken, worn, or not seated properly Allow adequate time for the rings to seat. Replace worn piston rings as necessary. • Piston and rings improperly installed or not fitted to the cylinder bore

Oil Pressure Diagnosis and Testing

SIE-ID = 751579 LMD = 21-mar-2002

Tools Required

- J 21867 Pressure Gage
- J 42907 Oil Pressure Testing Tool



416607

1. With the vehicle on a level surface, run the vehicle for a few minutes. Allow adequate drain down time, 2–3 minutes, and measure the oil level.
2. If required, add the recommended grade engine oil and fill the crankcase until the oil level measures full on the oil level indicator.
3. Run the engine briefly, 10–15 seconds, and verify low or no oil pressure on the vehicle gage or light.
4. Listen for a noisy valve train or a knocking noise.
5. Inspect for the following:

- Oil diluted by water or glycol anti freeze
 - Foamy oil
6. Remove the oil filter and install the J 42907.
 7. Install J 21867 or equivalent to the J 42907.
 8. Run the engine and measure the engine oil pressure.
 9. Compare the readings to *Engine Mechanical Specifications (LR4 VIN V)* or *Engine Mechanical Specifications (LM7 VIN T)* or *Engine Mechanical Specifications (L59 VIN Z)* or *Engine Mechanical Specifications (LQ4 VIN U)* or *Engine Mechanical Specifications (LQ9 VIN N)*.
 10. If the engine oil pressure is below specifications, inspect the engine for one or more of the following:
 - Oil pump worn or dirty
Refer to *Oil Pump Cleaning and Inspection*.
 - Oil pump-to-engine block bolts loose
Refer to *Oil Pump, Pump Screen and Deflector Installation*.
 - Oil pump screen loose, plugged, or damaged
 - Oil pump screen O-ring seal missing or damaged
 - Malfunctioning oil pump pressure regulator valve
 - Excessive bearing clearance
 - Cracked, porous, or restricted oil galleries
 - Oil gallery plugs missing or incorrectly installed
Refer to *Engine Block Plug Installation*.
 - Broken valve lifters
Repair as necessary.
 11. If the oil pressure reading on the J 21867 or equivalent is within specifications, inspect for the following:
 - Plugged or incorrect oil filter and/or malfunctioning oil bypass valve

- Malfunctioning oil pressure gage or sensor
Repair as necessary.

SIE-ID = 204344 LMD = 01-jun-2001

Oil Leak Diagnosis

Step	Action	Yes	No
<p>Important: You can repair most fluid leaks by first visually locating the leak, repairing or replacing the component, or by resealing the gasket surface. Once the leak is identified, determine the cause of the leak. Repair the cause of the leak as well as the leak itself.</p>			
1	<ol style="list-style-type: none"> 1. Operate the vehicle until it reaches normal operating temperature. 2. Park the vehicle on a level surface, over a large sheet of paper or other clean surface. 3. Wait 15 minutes. 4. Check for drippings. <p>Are drippings present?</p>	Go to <i>Step 2</i>	System OK
2	Can you identify the type of fluid and the approximate location of the leak?	Go to <i>Step 10</i>	Go to <i>Step 3</i>
3	<ol style="list-style-type: none"> 1. Visually inspect the suspected area. Use a small mirror to assist in looking at hard to see areas. 2. Check for leaks at the following locations: <ul style="list-style-type: none"> • Sealing surfaces • Fittings • Cracked or damaged components <p>Can you identify the type of fluid and the approximate location of the leak?</p>	Go to <i>Step 10</i>	Go to <i>Step 4</i>
4	<ol style="list-style-type: none"> 1. Completely clean the entire engine and surrounding components. 2. Operate the vehicle for several kilometers – miles at normal operating temperature and at varying speeds. 3. Park the vehicle on a level surface, over a large sheet of paper or other clean surface. 4. Wait 15 minutes. 5. Identify the type of fluid, and the approximate location of the leak. <p>Can you identify the type of fluid and the approximate location of the leak?</p>	Go to <i>Step 10</i>	Go to <i>Step 5</i>
5	<ol style="list-style-type: none"> 1. Visually inspect the suspected area. Use a small mirror to assist in looking at hard to see areas. 2. Check for leaks at the following locations: <ul style="list-style-type: none"> • Sealing surfaces • Fittings • Cracked or damaged components <p>Can you identify the type of fluid and the approximate location of the leak?</p>	Go to <i>Step 10</i>	Go to <i>Step 6</i>
6	<ol style="list-style-type: none"> 1. Completely clean the entire engine and surrounding components. 2. Apply an aerosol-type powder, baby powder, foot powder, etc., to the suspected area. 3. Operate the vehicle for several kilometers (miles) at normal operating temperature and at varying speeds. 4. Identify the type of fluid, and the approximate location of the leak, from the discolorations in the powder surface. <p>Can you identify the type of fluid and the approximate location of the leak?</p>	Go to <i>Step 10</i>	Go to <i>Step 7</i>

Oil Leak Diagnosis (cont'd)

Step	Action	Yes	No
7	1. Visually inspect the suspected area. Use a small mirror to assist in looking at hard to see areas. 2. Check for leaks at the following locations: <ul style="list-style-type: none"> • Sealing surfaces • Fittings • Cracked or damaged components Can you identify the type of fluid and the approximate location of the leak?	Go to Step 10	Go to Step 8
8	Use J 28428-E High Intensity Black Light Kit in order to identify the type of fluid, and the approximate location of the leak. Refer to the manufacturer's instructions when using the tool. Can you identify the type of fluid and the approximate location of the leak?	Go to Step 10	Go to Step 9
9	1. Visually inspect the suspected area. Use a small mirror to assist in looking at hard to see areas. 2. Check for leaks at the following locations: <ul style="list-style-type: none"> • Sealing surfaces • Fittings • Cracked or damaged components Can you identify the type of fluid and the approximate location of the leak?	Go to Step 10	System OK
10	1. Inspect the engine for mechanical damage. Special attention should be shown to the following areas: <ul style="list-style-type: none"> • Higher than recommended fluid levels • Higher than recommended fluid pressures • Plugged or malfunctioning fluid filters or pressure bypass valves • Plugged or malfunctioning engine ventilation system • Improperly tightened or damaged fasteners • Cracked or porous components • Improper sealants or gaskets where required • Improper sealant or gasket installation • Damaged or worn gaskets or seals • Damaged or worn sealing surfaces 2. Inspect the engine for customer modifications. Is there mechanical damage, or customer modifications to the engine?	Go to Step 11	System OK
11	Repair or replace all damaged or modified components. Does the engine still leak oil?	Go to Step 1	System OK

SIE-ID = 718028 LMD = 20-apr-2001

Crankcase Ventilation System Inspection/Diagnosis

Symptom	Correction
External oil leak	Inspect for any of the following conditions: <ul style="list-style-type: none"> • Restricted positive crankcase ventilation (PCV) valve • Restricted or kinked PCV hose or engine vent hose • Damaged, incorrect, or incorrectly installed PCV valve or hose • Excessive crankcase pressure
Rough Idle	Inspect for any of the following conditions: <ul style="list-style-type: none"> • Restricted PCV valve • Restricted or kinked PCV hose or engine vent hose • Leaking (damaged) PCV valve or hose • Vacuum hoses worn or not properly installed

Crankcase Ventilation System Inspection/Diagnosis (cont'd)

Symptom	Correction
Stalling or slow idle speed	Inspect for any of the following conditions: <ul style="list-style-type: none"> • Restricted PCV valve • Restricted or kinked PCV hose or engine vent hose • Leaking (damaged) PCV valve or hose
High idle speed	Inspect for a leaking (damaged) PCV valve or hose
Sludge in the engine	Inspect for any of the following conditions: <ul style="list-style-type: none"> • Restricted PCV valve • Restricted or kinked PCV hose or engine vent hose

Drive Belt Chirping Diagnosis

SIE-ID = 669743 LMD = 18-oct-2000

Diagnostic Aids

The chirping noise may be intermittent due to moisture on the drive belt(s) or the accessory drive pulley(s). In order to duplicate the customer's concern, it may be necessary to spray a small amount of water onto the drive belt(s). If spraying water onto the drive belt(s) duplicates the symptom, cleaning the accessory drive pulley(s) may be the most probable solution.

A loose or improper installation of a body or suspension component, or other item(s) on the vehicle may also cause the chirping noise.

Test Description

The number(s) below refer to the step(s) in the diagnostic table.

- The chirping noise may not be engine related. This step is to verify that the engine is making the noise. If the engine is not making the noise do not proceed any further in this table.
- The noise may be an internal engine noise. Remove the drive belt(s) and operate the engine for a few seconds, this will verify if the chirping noise is related to the drive belt(s) or not. With the drive belt(s) removed the water pump will not operate and the engine may overheat. Also diagnostic trouble codes (DTCs) may set when the engine is operated with the drive belt(s) removed.

- Inspect the drive belt(s) for signs of pilling. Pilling is the small balls, pills, or strings in the drive belt grooves caused by the accumulation of rubber dust.
- Misalignment of the accessory drive pulley(s) may be caused from improper mounting or incorrect installation of an accessory drive component, or the pulley may be bent inward or outward from a previous repair. Test for a misaligned accessory drive pulley using a straight edge in the pulley grooves across two or three pulleys. If a misaligned pulley is found, refer to that accessory drive component for the proper removal and installation procedure for that pulley.
- Inspection of the fasteners can eliminate the possibility that a incorrect bolt, nut, spacer, or washer was installed.
- Inspection of the accessory drive pulley(s) should include inspecting for bends, dents, or other damage to the pulley(s) that would prevent the drive belt(s) from seating properly in the pulley grooves or on the smooth surface of the pulley when the back side of the drive belt is used to drive the pulley.
- Replacing the drive belt(s) when it is not damaged or there is not excessive pilling will only be a temporary repair.

Drive Belt Chirping Diagnosis

Step	Action	Yes	No
<p>Notice: Refer to <i>Belt Dressing Notice</i> in Cautions and Notices.</p> <p>DEFINITION: The following items are indications of chirping:</p> <ul style="list-style-type: none"> • A high pitched noise that is heard once per revolution of the drive belt(s) or a accessory drive pulley. • Chirping may occur on cold damp startup conditions and will subside once the vehicle reaches normal operating temperature. 			
1	Did you review the Symptoms - Engine Mechanical diagnostic information, and perform the necessary inspections?	Go to Step 2	Go to <i>Symptoms - Engine Mechanical</i>
2	Verify that there is a chirping noise. Does the engine make the chirping noise?	Go to Step 3	Go to Diagnostic Aids
3	1. Remove the drive belt(s). Refer to <i>Drive Belt Replacement - Accessory</i> or <i>Drive Belt Replacement - Air Conditioning</i> . 2. Operate the engine for no longer than 30 to 40 seconds. Does the chirping noise still exist?	Go to <i>Engine Noise on Start-Up, but Only Lasting a Few Seconds</i>	Go to Step 4

Drive Belt Chirping Diagnosis (cont'd)

Step	Action	Yes	No
4	Inspect for severe drive belt pilling exceeding 1/3 of the drive belt groove depth. Do the drive belt grooves have pilling?	Go to Step 5	Go to Step 6
5	Clean the accessory drive pulley(s) with a suitable wire brush. Were the accessory drive pulley(s) cleaned?	Go to Step 15	—
6	Inspect for a misaligned accessory drive pulley(s). Is there a misaligned accessory drive pulley(s)?	Go to Step 7	Go to Step 8
7	Replace and/or repair the misaligned accessory drive pulley(s). Were the misaligned accessory drive pulley(s) replaced and/or repaired?	Go to Step 15	—
8	Inspect for a bent or cracked accessory drive bracket(s). Did you find any bent or cracked accessory drive bracket(s)?	Go to Step 9	Go to Step 10
9	Replace the bent and/or cracked accessory drive bracket(s). Was the bent and/or cracked accessory drive bracket(s) replaced?	Go to Step 15	—
10	Inspect for incorrect, loose and/or missing fasteners. Were there any incorrect, loose, and/or missing fasteners found?	Go to Step 11	Go to Step 12
11	1. Replace any incorrect and/or missing fasteners. 2. Tighten any loose fasteners. Refer to <i>Fastener Tightening Specifications</i> . Were the fasteners replaced and/or tightened?	Go to Step 15	—
12	Inspect for a bent accessory drive pulley(s). Was a bent accessory drive pulley(s) found?	Go to Step 13	Go to Step 14
13	Replace the bent accessory drive pulley(s). Was the bent accessory drive pulley(s) replaced?	Go to Step 15	—
14	Replace the drive belt(s). Refer to <i>Drive Belt Replacement - Accessory or Drive Belt Replacement - Air Conditioning</i> . Was the drive belt(s) replaced?	Go to Step 15	—
15	1. Clear any codes. 2. Run the engine in order to verify the repair. Does the chirping noise still exist?	—	System OK

Drive Belt Squeal Diagnosis

SIE-ID = 669744 LMD = 18-oct-2000

Diagnostic Aids

A loose or improper installation of a body, or suspension component, or other item(s) on the vehicle may cause the squeal noise.

If the squeal is intermittent, verify that it is not the accessory drive component(s) by varying their load(s), making sure they are operating to their maximum capacity. An overcharged air conditioning (A/C) system, a power steering system restriction or the incorrect fluid, or a failing generator are suggested items to inspect.

Test Description

The number(s) below refer to the step(s) in the diagnostic table.

- 2. The squeal may not be engine related. This step is to verify that the engine is making the noise. If the engine is not making the noise do not proceed further in this table

- 3. The squeal may be an internal engine noise. Remove the drive belt(s) and operate the engine for a few seconds, this will verify if the squealing noise is related to the drive belt(s) or an accessory drive component. With the drive belt(s) removed the water pump will not operate and the engine may overheat. Also diagnostic trouble codes (DTCs) may set when the engine is operated with the drive belt(s) removed.
- 4. This test is to verify that an accessory drive component(s) does not have a seized bearing. With the belt(s) removed, test the bearings in the accessory drive component(s) for smooth operation. Also test the accessory drive component(s) with the engine operating by varying the load on the accessory drive component(s) to verify that the component(s) is operating properly.
- 5. This test is to verify that the drive belt(s) tensioner(s) are not operating properly. If the drive belt tensioner(s) are not operating properly,

proper belt tension may not be achieved to keep the drive belt(s) from slipping which could cause a squealing noise.

6. This test is to verify that the drive belt(s) is not too long, which would prevent the drive belt tensioner(s) from operating properly. Also if the incorrect length drive belt(s) was installed, it may not be routed correctly and may be turning an accessory drive component in the incorrect direction.
7. Misalignment of the accessory drive pulley(s) may be caused from improper mounting or incorrect installation of a accessory drive component, or the

pulley may be bent inward or outward from a previous repair. Test for a misaligned pulley using a straight edge in the pulley grooves across two or three pulleys. If a misaligned pulley is found, refer to that accessory drive component for the proper removal and installation procedure for that pulley.

8. Inspect the accessory drive pulley(s) to verify that they are the correct diameter or width. Using a known good vehicle, compare the accessory drive pulleys.

Drive Belt Squeal Diagnosis

Step	Action	Yes	No
<p>Notice: Refer to <i>Belt Dressing Notice</i> in Cautions and Notices. DEFINITION: The following items are indications of drive belt squeal:</p> <ul style="list-style-type: none"> • A loud screeching noise that is caused by a slipping drive belt(s) (this is unusual for a drive belt with multiple ribs) • The squeal occurs when a heavy load is applied to the drive belt(s), such as an A/C compressor engagement, snapping the throttle, slipping on a seized pulley, or a faulty accessory drive component. 			
1	Did you review the Symptoms - Engine Mechanical diagnostic information, and perform the necessary inspections?	Go to Step 2	Go to Symptoms - Engine Mechanical
2	Verify that there is a squealing noise. Does the engine make the squeal noise?	Go to Step 3	Go to Diagnostic Aids
3	1. Remove the drive belt(s). Refer to <i>Drive Belt Replacement - Accessory</i> or <i>Drive Belt Replacement - Air Conditioning</i> . 2. Operate the engine for no longer than 30 to 40 seconds. Does the squealing noise still exist?	Go to Engine Noise on Start-Up, but Only Lasting a Few Seconds	Go to Step 4
4	Inspect for a seized accessory drive component bearing or a faulty accessory drive component. Did you find and correct the condition?	Go to Step 9	Go to Step 5
5	Inspect the drive belt tensioner for proper operation. Refer to <i>Drive Belt Tensioner Diagnosis</i> . Did you find and correct the condition?	Go to Step 9	Go to Step 6
6	Check for the correct length drive belt(s). Did you find and correct the condition?	Go to Step 9	Go to Step 7
7	Inspect for a misaligned pulley. Did you find and correct the condition?	Go to Step 9	Go to Step 8
8	Inspect for an incorrect size pulley. Did you find and correct the condition?	Go to Step 9	—
9	1. Install the drive belt(s). Refer to <i>Drive Belt Replacement - Accessory</i> or <i>Drive Belt Replacement - Air Conditioning</i> . 2. Clear any codes. 3. Run the engine in order to verify the repair. Does the squealing noise still exist?	—	System OK

Drive Belt Whine Diagnosis

SIE-ID = 669748 LMD = 18-oct-2000

Diagnostic Aids

The drive belt(s) will not cause the whine.
If the whine is intermittent, verify that it is not the accessory drive component(s) by varying their loads, making sure they are operating to their maximum capacity. An overcharged air conditioning (A/C)

system, a power steering system restriction or the incorrect fluid, or a failing generator are suggested items to inspect.

Test Description

The number(s) below refer to the step(s) in the diagnostic table.
3. This test is to verify that the whine is being caused by the accessory drive component(s). Remove the drive belt(s) and operate the engine for a few seconds, this will verify if the whining

noise is related to the accessory drive component. With the drive belt(s) removed the water pump will not operate and the engine may overheat. Also diagnostic trouble codes (DTCs) may set when the engine is operated with the drive belt(s) removed.

installed and the accessory drive components operated separately by varying their loads. Refer to the suspected accessory drive component for the proper removal and installation procedure.

- This inspection should include checking the drive belt tensioner and the drive belt idler pulley bearings. The drive belt(s) may have to be

Drive Belt Whine Diagnosis

Step	Action	Yes	No
Notice: Refer to <i>Belt Dressing Notice</i> in Cautions and Notices.			
DEFINITION: A high pitched continuous noise that may be caused by an accessory drive component failed bearing.			
1	Did you review the Symptoms - Engine Mechanical diagnostic information, and perform the necessary inspections?	Go to Step 2	Go to <i>Symptoms - Engine Mechanical</i>
2	Verify that there is a whining noise. Does the engine make the whining noise?	Go to Step 3	Go to Diagnostic Aids
3	1. Remove the drive belt(s). Refer to <i>Drive Belt Replacement - Accessory</i> or <i>Drive Belt Replacement - Air Conditioning</i> . 2. Operate the engine for no longer than 30 to 40 seconds. Does the whining noise still exist?	Go to <i>Engine Noise on Start-Up, but Only Lasting a Few Seconds</i>	Go to Step 4
4	1. Inspect for a failed accessory drive component bearing. 2. Install the drive belt(s). Refer to <i>Drive Belt Replacement - Accessory</i> or <i>Drive Belt Replacement - Air Conditioning</i> . Did you find and correct the condition?	Go to Step 5	—
5	1. Clear any codes. 2. Run the engine in order to verify the repair. Does the whining still exist?	—	System OK

Drive Belt Rumbling Diagnosis

SIE-ID = 669750 LMD = 18-oct-2000

Diagnostic Aids

Vibration from the engine operating may cause a body component or another part of the vehicle to make rumbling noise.

The drive belt(s) may have a condition that can not be seen or felt. Sometimes replacing the drive belt(s) may be the only repair for the symptom.

If after replacing the drive belt(s) and completing the diagnostic table, the rumbling is only heard with the drive belt(s) installed, there might be an accessory drive component failure. Varying the load on the accessory drive component(s) may aid in identifying which component is causing the rumbling noise.

Test Description

The number(s) below refer to the step(s) in the diagnostic table.

- This test is to verify that the symptom is present during diagnosing. Other vehicle components may cause a similar symptom.

- This test is to verify that the drive belt(s) is causing the rumbling. Rumbling may be confused with an internal engine noise due to the similarity in the description. Remove only one drive belt at a time if the vehicle has multiple drive belts. Operate the engine for a few seconds, this will verify if the rumbling noise is related to the drive belt(s) or not. With the drive belt(s) removed the water pump will not operate and the engine may overheat. Also diagnostic trouble codes (DTCs) may set when the engine is operated with the drive belt(s) removed.

- Inspect the drive belt(s) to ensure that the drive belt(s) is not the cause of the noise. Small cracks across the ribs of the drive belt(s) will not cause the noise. Belt separation is identified by the plys of the belt separating, this may be seen at the edge of the belt or felt as a lump in the belt.
- Small amounts of pilling is a normal condition and acceptable. When the pilling is severe the drive belt(s) does not have a smooth surface for proper operation.

Drive Belt Rumbling Diagnosis

Step	Action	Yes	No
<p>Notice: Refer to <i>Belt Dressing Notice</i> in Cautions and Notices.</p> <p>DEFINITION:</p> <ul style="list-style-type: none"> A low pitch tapping, knocking, or thumping noise heard at or just above idle. Heard once per revolution of the drive belt(s) or pulley(s). Rumbling may be caused from: <ul style="list-style-type: none"> Pilling, the accumulation of rubber dust that forms small balls (pills) or strings in the drive belt(s) pulley groove The separation of the drive belt(s) A damaged drive belt(s) 			
1	Did you review the Symptoms - Engine Mechanical diagnostic information, and perform the necessary inspections?	Go to Step 2	Go to <i>Symptoms - Engine Mechanical</i>
2	Verify that there is a rumbling noise. Does the engine make the rumbling noise?	Go to Step 3	Go to Diagnostic Aids
3	1. Remove the drive belt(s). Refer to <i>Drive Belt Replacement - Accessory</i> or <i>Drive Belt Replacement - Air Conditioning</i> . 2. Operate the engine for no longer than 30 to 40 seconds. Does the rumbling noise still exist?	Go to <i>Engine Noise on Start-Up, but Only Lasting a Few Seconds</i>	Go to Step 4
4	Inspect the drive belt(s) for damage, separation, or sections of missing ribs. Were any of these conditions found?	Go to Step 7	Go to Step 5
5	Inspect for severe pilling of more than 1/3 of the drive belt groove depth. Do the drive belt grooves have pilling?	Go to Step 6	Go to Step 7
6	1. Clean the drive belt pulleys using a suitable wire brush. 2. Reinstall the drive belt(s). Refer to <i>Drive Belt Replacement - Accessory</i> or <i>Drive Belt Replacement - Air Conditioning</i> . Did you complete the repair?	Go to Step 8	—
7	Install a new drive belt(s). Refer to <i>Drive Belt Replacement - Accessory</i> or <i>Drive Belt Replacement - Air Conditioning</i> . Did you complete the replacement?	Go to Step 8	—
8	1. Clear any codes. 2. Run the engine in order to verify the repair. Does the rumbling noise still exist?	—	System OK

Drive Belt Vibration Diagnosis

SIE-ID = 669754 LMD = 18-oct-2000

Diagnostic Aids

The accessory drive components may have an affect on engine vibration. An overcharged air conditioning (A/C) system, a power steering system restriction, or the incorrect fluid, or an extra load placed on the generator are suggested items to inspect. To help identify an intermittent or an improper condition, vary the loads on the accessory drive components.

Test Description

The number(s) below refer to the step(s) in the diagnostic table.

- This test is to verify that the vibration is present during diagnosing. Other vehicle components may cause a similar symptom such as the exhaust system, or the drivetrain.
- This test is to verify that the drive belt(s) or accessory drive components may be causing the vibration. Remove the drive belt(s) and operate

the engine for a few seconds, this will verify if the vibration is related to the drive belt(s) or not. With the drive belt(s) removed the water pump will not operate and the engine may overheat. Also diagnostic trouble codes (DTCs) may set when the engine is operated with the drive belt(s) removed.

- The drive belt(s) may cause a vibration. While the drive belt(s) is removed this is the best time to inspect the condition of the drive belt(s).
- Inspection of the fasteners can eliminate the possibility that a incorrect bolt, nut, spacer, or washer was installed.
- This step should only be performed if the fan is driven by the drive belt. Inspect the engine cooling fan for bent, twisted, loose, or cracked blades. Inspect the fan clutch for smooth operation. Inspect for a bent fan shaft or bent mounting flange.
- Inspect the water pump drive shaft for being bent. Also inspect the water pump bearings for smooth operation and excessive play. Compare the water pump with a known, good water pump.

- Accessory drive component brackets that are bent, cracked, or loose may put an extra strain on that accessory drive component causing it to vibrate.

Drive Belt Vibration Diagnosis

Step	Action	Yes	No
<p>Notice: Refer to <i>Belt Dressing Notice</i> in Cautions and Notices. DEFINITION: The following items are indications of drive belt vibration:</p> <ul style="list-style-type: none"> The vibration is engine-speed related. The vibration may be sensitive to accessory load. 			
1	Did you review the Symptoms - Engine Mechanical diagnostic information, and perform the necessary inspections?	Go to <i>Step 2</i>	Go to <i>Symptoms - Engine Mechanical</i>
2	Verify that the vibration is engine related. Does the engine make the vibration?	Go to <i>Step 3</i>	Go to Diagnostic Aids
3	1. Remove the drive belt(s). Refer to <i>Drive Belt Replacement - Accessory</i> or <i>Drive Belt Replacement - Air Conditioning</i> . 2. Operate the engine for no longer than 30 to 40 seconds. Does the engine still make the vibration?	Go to <i>Diagnostic Starting Point - Vibration Diagnosis and Correction</i> in <i>Vibration Diagnosis and Correction</i>	Go to <i>Step 4</i>
4	Inspect the drive belt(s) for wear, damage, debris build-up and missing drive belt ribs. Were any of these conditions found?	Go to <i>Step 5</i>	Go to <i>Step 6</i>
5	Install a new drive belt(s). Refer to <i>Drive Belt Replacement - Accessory</i> or <i>Drive Belt Replacement - Air Conditioning</i> . Did you complete the replacement?	Go to <i>Step 11</i>	—
6	Inspect for incorrect, loose, and/ or missing fasteners. Were any of these conditions found?	Go to <i>Step 7</i>	Go to <i>Step 8</i>
7	Replace any incorrect and/or missing fastener. Tighten any loose fasteners. Refer to <i>Fastener Tightening Specifications</i> . Were the fasteners replaced and/or tightened?	Go to <i>Step 11</i>	—
8	Inspect for damaged fan blades or a bent fan clutch shaft. Did you find and correct the condition?	Go to <i>Step 11</i>	Go to <i>Step 9</i>
9	Inspect for a bent water pump drive shaft. Did you find and correct the condition?	Go to <i>Step 11</i>	Go to <i>Step 10</i>
10	Inspect for a bent or cracked accessory drive bracket(s). Did you find and correct the condition?	Go to <i>Step 11</i>	—
11	1. Clear any codes. 2. Run the engine in order to verify the repair. Does the vibration still exist?	—	System OK

Drive Belt Falls Off Diagnosis

SIE-ID = 669757 LMD = 07-feb-2001

Diagnostic Aids

If the drive belt(s) repeatedly falls off the accessory drive pulley(s), this may be caused by a pulley misalignment.

An extra load that is quickly applied or released by an accessory drive component may also cause the drive belt(s) to fall off. Verify that the accessory drive component(s) are operating properly.

If the drive belt(s) is the incorrect length, the drive belt tensioner may not maintain the proper tension on the drive belt(s).

Test Description

The number(s) below refer to the step(s) in the diagnostic table.

- This inspection is to verify the condition of the drive belt(s). Damage may have occurred to the drive belt(s) when the drive belt(s) fell off the pulley. Inspect the drive belt(s) for cuts, tears, sections of ribs missing, or damaged belt plys.
- Misalignment of the accessory drive pulley(s) may be caused from improper mounting or incorrect installation of a accessory drive component, or the pulley may be bent inward or outward from a previous repair. Test for a misaligned pulley using a straight edge in the pulley grooves across two or three pulleys. If a misaligned pulley is

- found, refer to that accessory drive component for the proper removal and installation procedure of that pulley.
5. Inspection of the accessory drive pulley(s) should include inspecting for bends, dents, or other damage that would prevent the drive belt from seating properly in the pulley grooves or on the smooth surface of a pulley when the back side of the drive belt(s) is used to drive the pulley.
 6. Accessory drive component brackets that are bent or cracked will also cause the drive belt(s) to fall off.
 7. Inspection of the fasteners can eliminate the possibility that a incorrect bolt, nut, spacer, or washer was installed. Missing, loose, or incorrect fasteners may cause pulley misalignment from the accessory drive bracket(s) moving under load. Over tightening the fasteners may cause misalignment of the accessory component bracket(s).

Drive Belt Falls Off Diagnosis

Step	Action	Yes	No
Notice: Refer to <i>Belt Dressing Notice</i> in Cautions and Notices.			
DEFINITION: The drive belt(s) falls off the pulleys or may not ride correctly on the pulleys.			
1	Did you review the Symptoms - Engine Mechanical diagnostic information, and perform the necessary inspections?	Go to Step 2	Go to Symptoms - Engine Mechanical
2	Inspect for a damaged drive belt(s). Was a damaged drive belt(s) found?	Go to Step 3	Go to Step 4
3	Install a new drive belt(s). Refer to <i>Drive Belt Replacement - Accessory</i> or <i>Drive Belt Replacement - Air Conditioning</i> . Does the drive belt(s) continue to fall off?	Go to Step 4	System OK
4	Inspect for a misaligned accessory drive pulley(s). Did you find and correct the condition?	Go to Step 12	Go to Step 5
5	Inspect for a bent or dented accessory drive pulley(s). Did you find and correct the condition?	Go to Step 12	Go to Step 6
6	Inspect for a bent or a cracked accessory drive bracket(s). Did you find and correct the condition?	Go to Step 12	Go to Step 7
7	Inspect for incorrect, loose and/or missing fasteners. Were there any incorrect, loose and/or missing fasteners?	Go to Step 8	Go to Step 9
8	1. Replace any incorrect and/or missing fasteners. 2. Tighten any loose fasteners. Refer to <i>Fastener Tightening Specifications</i> . Does the drive belt continue to fall off?	Go to Step 9	System OK
9	Test the drive belt tensioner for correct operation. Refer to <i>Drive Belt Tensioner Diagnosis</i> . Does the drive belt tensioner operate correctly?	Go to Step 11	Go to Step 10
10	Replace the drive belt tensioner. Refer to <i>Drive Belt Tensioner Replacement - Accessory</i> or <i>Drive Belt Tensioner Replacement - Air Conditioning</i> . Does the drive belt continue to fall off?	Go to Step 11	System OK
11	Inspect for a failed drive belt idler and/or tensioner pulley bearing. Did you find and repair the condition?	Go to Step 12	—
12	Run the engine in order to verify the repair. Does the drive belt still fall off?	—	System OK

Drive Belt Excessive Wear Diagnosis

SIE-ID = 669759 LMD = 18-oct-2000

Diagnostic Aids

Excessive wear on a drive belt(s) is usually caused by incorrect installation or the incorrect drive belt(s) for the application.

Minor misalignment of the accessory drive pulley(s) will not cause excessive wear, but will probably cause the drive belt(s) to make a noise or fall off.

Excessive misalignment of the accessory drive pulley(s) will cause excessive wear and may also make the drive belt(s) fall off.

Test Description

The number(s) below refer to the step(s) in the diagnostic table.

2. This inspection is to verify that the drive belt(s) is correctly installed on all of the accessory drive pulleys. Wear on the drive belt(s) may be caused by mis-positioning the drive belt(s) by one or more grooves on a pulley(s).
3. The installation of a drive belt(s) that is too wide or too narrow will cause wear on the drive belt(s). The drive belt(s) ribs should match all of the grooves on the pulleys.

4. This inspection is to verify that the drive belt(s) is not contacting any part of the engine or body while the engine is operating. There should be sufficient clearance when the accessory drive components load varies. The drive belt(s) should not come in contact with an engine or a body component when snapping the throttle.

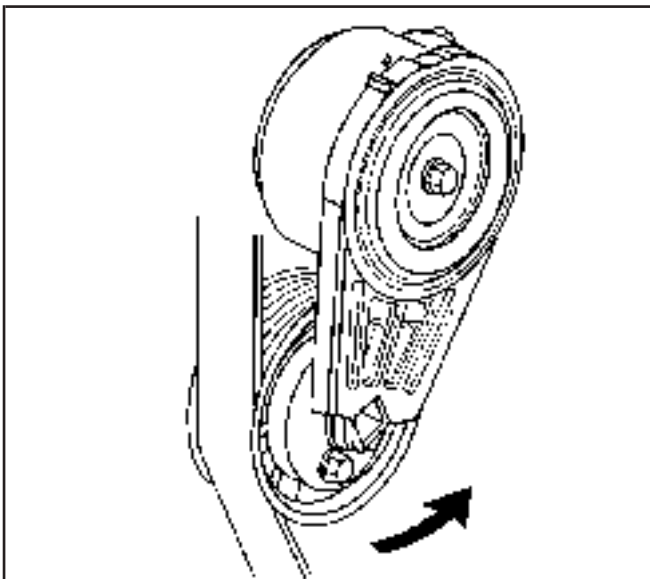
Drive Belt Excessive Wear Diagnosis

Step	Action	Yes	No
Notice: Refer to <i>Belt Dressing Notice</i> in Cautions and Notices.			
DEFINITION: Wear at the outside ribs of the drive belt(s) due to incorrect installation of the drive belt(s).			
1	Did you review the Symptoms - Engine Mechanical diagnostic information, and perform the necessary inspections?	Go to <i>Step 2</i>	Go to <i>Symptoms - Engine Mechanical</i>
2	Inspect the drive belt(s) for proper installation. Is the drive belt(s) installed properly?	Go to <i>Step 5</i>	Go to <i>Step 3</i>
3	Inspect for the correct drive belt(s). Is the correct drive belt installed?	Go to <i>Step 5</i>	Go to <i>Step 4</i>
4	Inspect the drive belt(s) for signs of rubbing against a bracket, hose, or wiring harness. Was the drive belt(s) rubbing against anything?	Go to <i>Step 5</i>	Go to Diagnostic Aids
5	Replace the drive belt(s). Refer to <i>Drive Belt Replacement - Accessory</i> or <i>Drive Belt Replacement - Air Conditioning</i> . Did you complete the replacement?	Go to <i>Step 6</i>	—
6	Run the engine in order to verify the repair. Is there still excessive drive belt wear?	—	System OK

Drive Belt Tensioner Diagnosis

SIE-ID = 669763 LMD = 17-aug-2000

Inspection Procedure



374176

Important: When the engine is operating the drive belt tensioner arm will move. Do not replace the drive belt tensioner because of movement in the drive belt tensioner arm.

1. Remove the drive belt. Refer to *Drive Belt Replacement - Accessory* or *Drive Belt Replacement - Air Conditioning*.
2. Move the drive belt tensioner through its full travel.
 - The movement should feel smooth.
 - There should be no binding.
 - The tensioner should return freely.
3. If any binding is observed, replace the drive belt tensioner. Refer to *Drive Belt Tensioner Replacement - Accessory* or *Drive Belt Tensioner Replacement - Air Conditioning*.
4. Install the drive belt. Refer to of *Drive Belt Replacement - Accessory* or *Drive Belt Replacement - Air Conditioning*.

Notice: SIO-ID = 3753 LMD = 18-aug-1995 Allowing the drive belt tensioner to snap into the free position may result in damage to the tensioner.

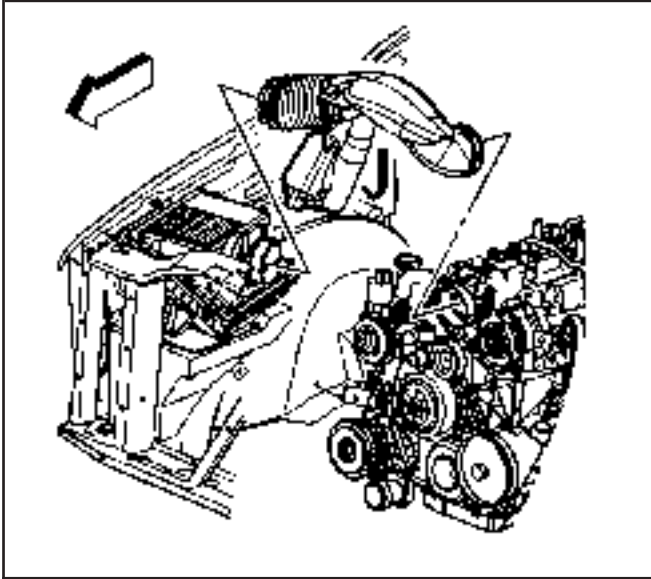
Repair Instructions

Drive Belt Replacement - Accessory

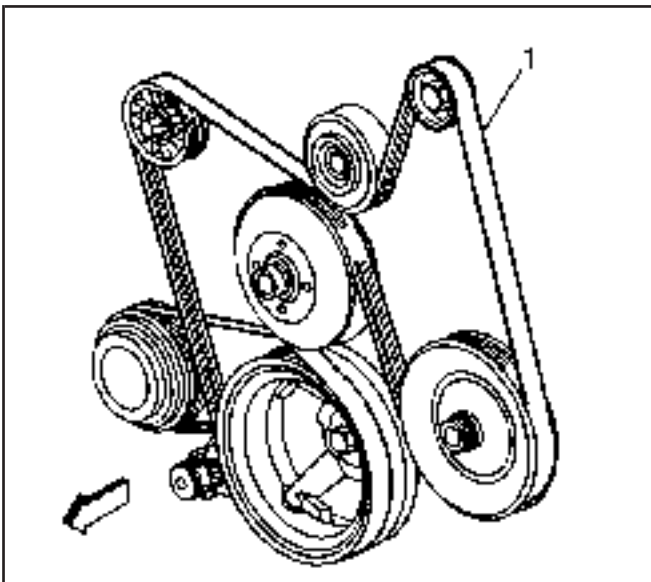
SIE-ID = 831036 LMD = 19-mar-2002

Removal Procedure

1. Loosen the air cleaner outlet duct clamps at the following locations:
 - The throttle body
 - The mass airflow/intake air temperature (MAF/IAT) sensor
 2. Disconnect the radiator inlet hose clip from the outlet duct.
 3. Remove the air cleaner outlet duct.
-
4. Install a breaker bar with hex-head socket to the drive belt tensioner bolt.
 5. Rotate the drive belt tensioner clockwise in order to relieve tension on the belt (1).
 6. Remove the belt (1) from the pulleys and the drive belt tensioner.
 7. Slowly release the tension on the drive belt tensioner.
 8. Remove the breaker bar and socket and from the drive belt tensioner bolt.
 9. Clean and inspect the belt surfaces of all the pulleys.



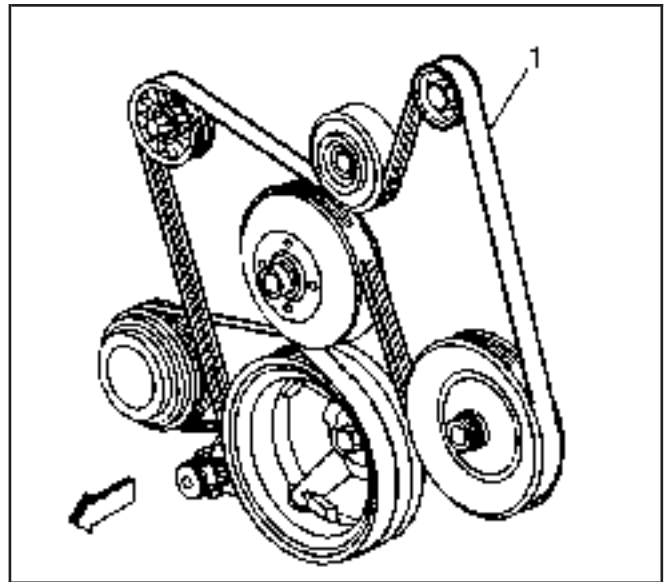
832066



833370

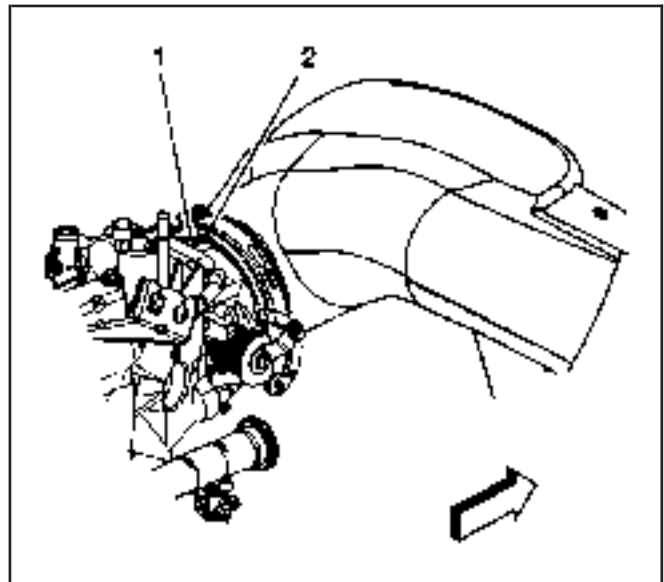
Installation Procedure

1. Route the drive belt (1) around all the pulleys except the idler pulley.
2. Install the breaker bar with hex-head socket to the belt tensioner bolt.
3. Rotate the belt tensioner clockwise in order to relieve the tension on the tensioner.
4. Install the drive belt (1) under the idler pulley.
5. Slowly release the tension on the belt tensioner.
6. Remove the breaker bar and socket from the belt tensioner bolt.
7. Inspect the drive belt (1) for proper installation and alignment.



833370

8. Align the arrow (2) at the throttle body end of the duct with the throttle body attaching stud (1).



832068

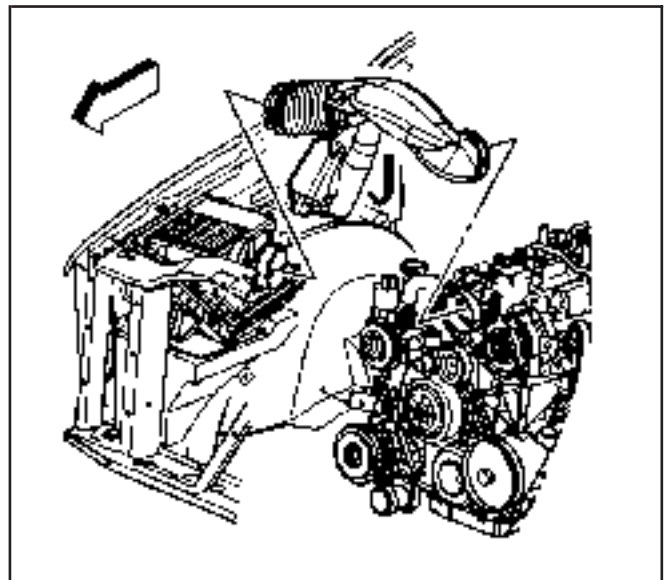
9. Install the air cleaner outlet duct.
10. Connect the radiator inlet hose clip to the outlet duct.

Notice: Refer to *Fastener Notice* in Cautions and Notices.

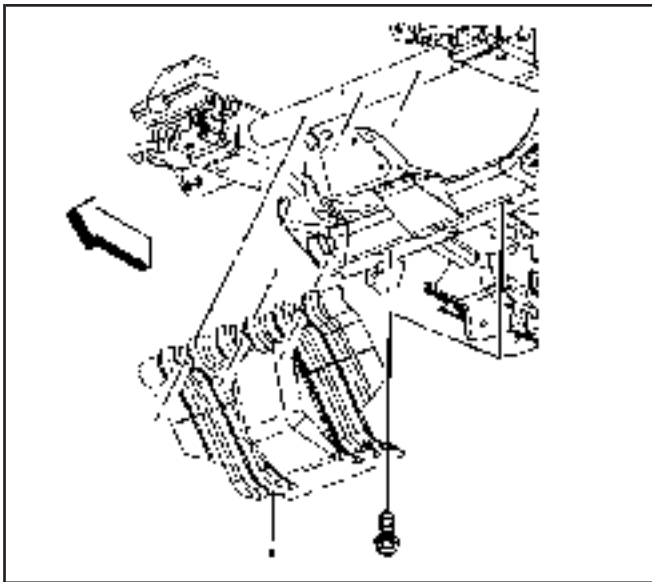
11. Tighten the air cleaner outlet duct clamp screws at the following locations:
 - The throttle body
 - The MAF/IAT sensor

Tighten

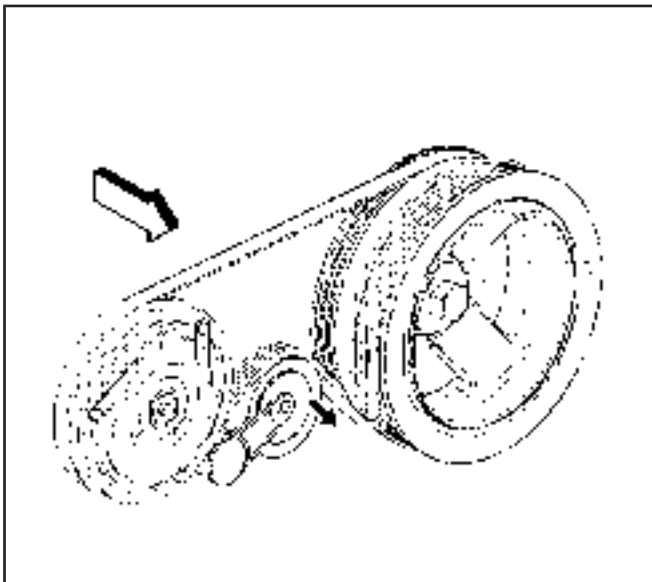
Tighten the screws to 7 N-m (62 lb in).



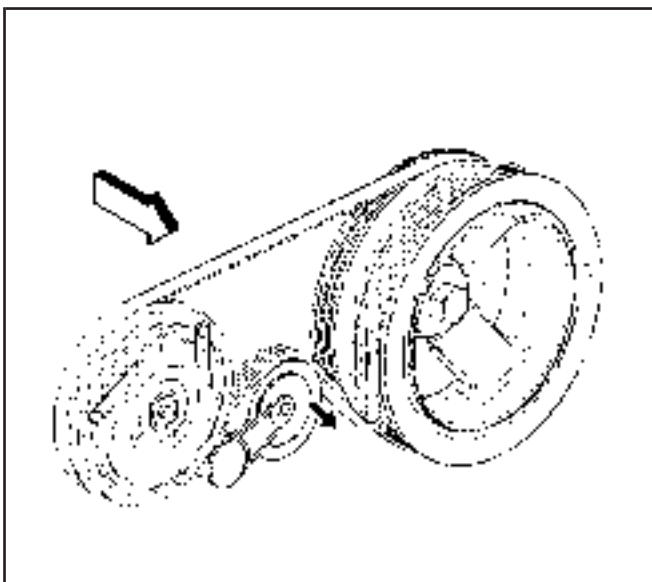
832066



349061



370869



370869

Drive Belt Replacement - Air Conditioning

SIE-ID = 642539 LMD = 28-may-2002

Removal Procedure

1. Remove the accessory drive belt. Refer to *Drive Belt Replacement - Accessory*.
2. Raise and suitably support the vehicle. Refer to *Lifting and Jacking the Vehicle* in General Information.
3. Remove the engine shield bolts.
4. Remove the engine shield.

5. Install a ratchet into the air conditioning (A/C) belt tensioner adapter opening.
6. Rotate the A/C belt tensioner clockwise in order to relieve tension on the belt.
7. Remove the A/C belt from the pulleys.
8. Slowly release the tension on the A/C belt tensioner.
9. Remove the ratchet from the A/C belt tensioner.
10. Clean and inspect the belt surfaces of all the pulleys.

Installation Procedure

1. Install the A/C belt around the crankshaft balancer.
2. Install a ratchet into the A/C drive belt tensioner adapter opening.
3. Rotate the A/C belt tensioner clockwise in order to relieve tension on the tensioner.
4. Install the A/C belt over the idler pulley.
5. Install the A/C belt around the A/C compressor pulley.
6. Slowly release the tension on the A/C belt tensioner.
7. Remove the ratchet from the A/C belt tensioner.
8. Inspect the A/C belt for proper installation and alignment.

9. Install the engine shield.

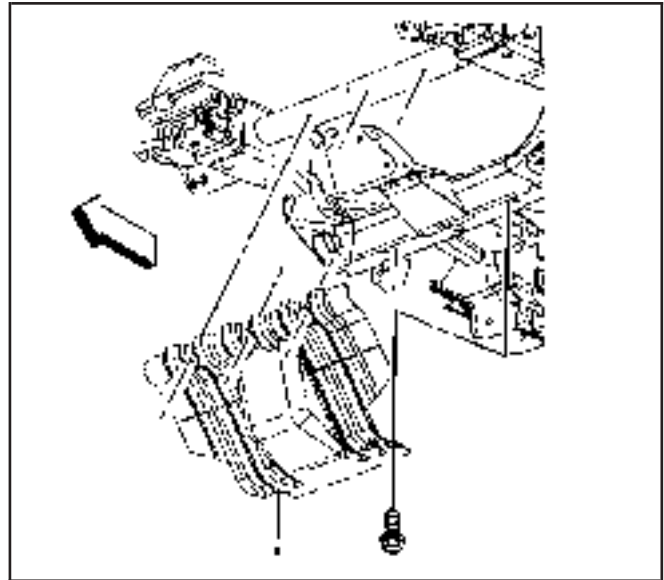
Notice: Refer to *Fastener Notice* in Cautions and Notices.

10. Install the engine shield bolts.

Tighten

Tighten the bolts to 20 N·m (15 lb ft).

11. Lower the vehicle.
12. Install the accessory drive belt. Refer to *Drive Belt Replacement - Accessory*.



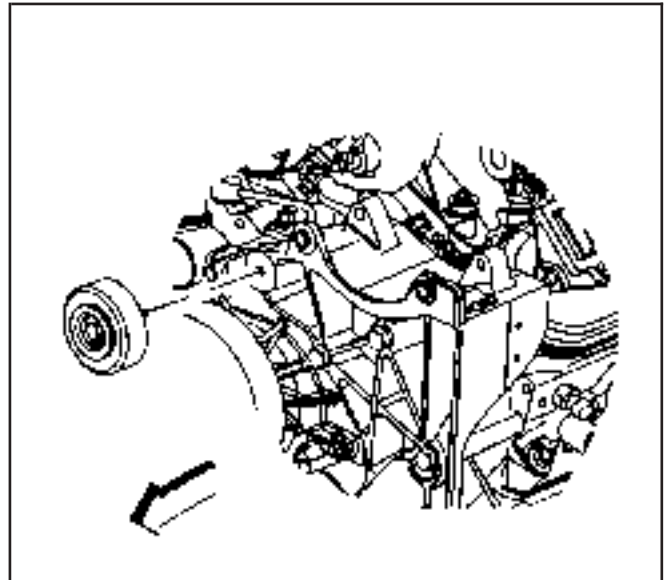
349061

Drive Belt Idler Pulley Replacement

SIE-ID = 642541 LMD = 28-may-2002

Removal Procedure

1. Loosen the drive belt idler pulley bolt.
2. Remove the accessory drive belt. Refer to *Drive Belt Replacement - Accessory*.
3. Remove the drive belt idler pulley and bolt.



678804

Installation Procedure

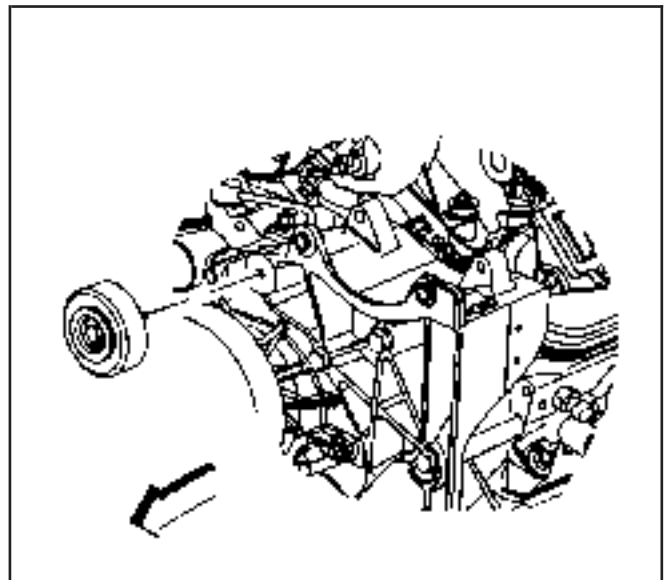
1. Install the drive belt idler pulley and bolt to the generator bracket.
Snug the bolt finger tight.
2. Install the drive belt. Refer to *Drive Belt Replacement - Accessory*.

Notice: Refer to *Fastener Notice* in Cautions and Notices.

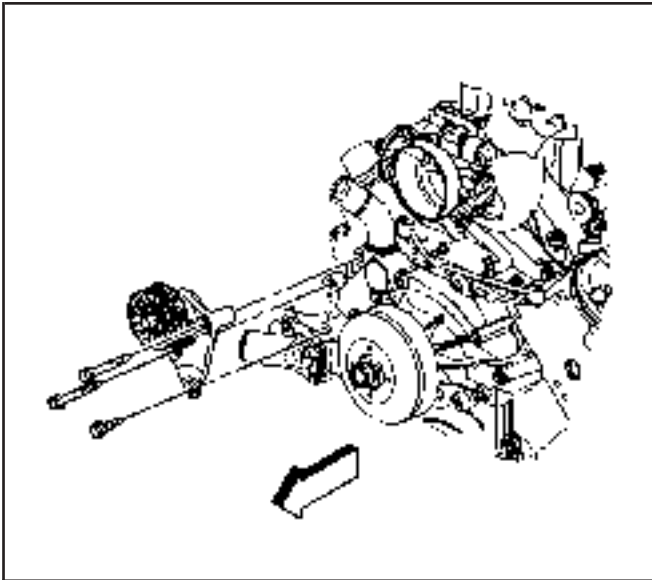
3. Tighten the drive belt idler pulley bolt.

Tighten

Tighten the bolt to 50 N·m (37 lb ft).



678804



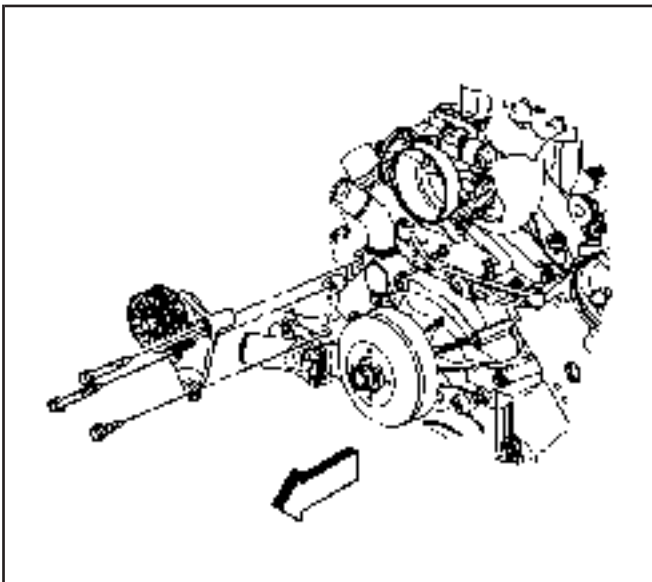
647789

Drive Belt Tensioner Replacement - Accessory

SIE-ID = 824710 LMD = 28-may-2002

Removal Procedure

1. Remove the accessory drive belt. Refer to *Drive Belt Replacement - Accessory*.
2. Remove the drive belt tensioner bolts.
3. Remove the drive belt tensioner.



647789

Installation Procedure

1. Install the drive belt tensioner.
2. Install the drive belt tensioner bolts.

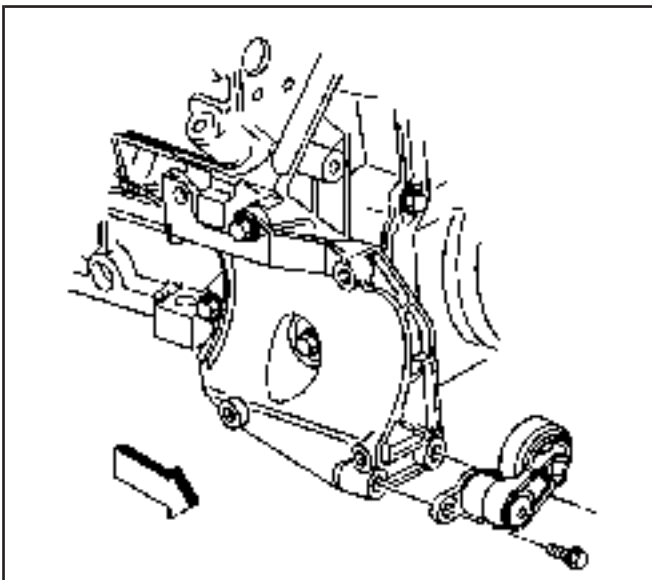
Notice: Refer to *Fastener Notice* in Cautions and Notices.

3. Tighten the drive belt tensioner bolts.

Tighten

Tighten the bolts to 50 N·m (37 lb ft).

4. Install the accessory drive belt. Refer to *Drive Belt Replacement - Accessory*.



678806

Drive Belt Tensioner Replacement - Air Conditioning

SIE-ID = 854307 LMD = 28-jan-2002

Removal Procedure

1. Remove the air conditioning (A/C) drive belt. Refer to *Drive Belt Replacement - Air Conditioning*.
2. Remove the A/C belt tensioner bolts.
3. Remove the A/C belt tensioner.

Installation Procedure

1. Install the A/C belt tensioner.

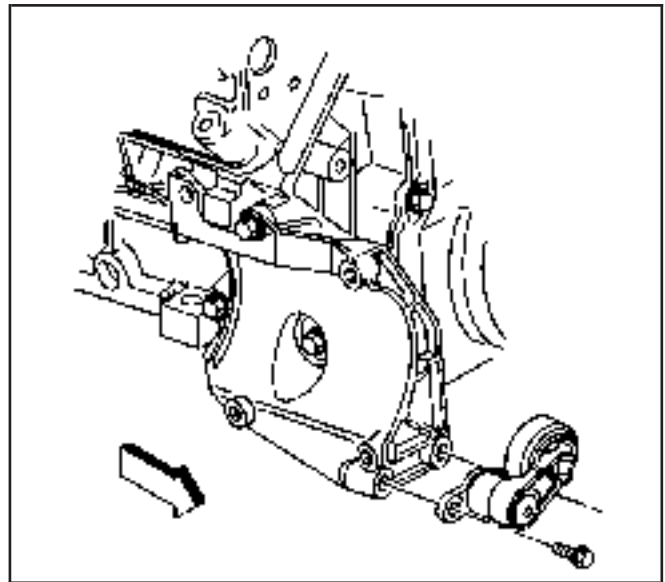
Notice: Refer to *Fastener Notice* in Cautions and Notices.

2. Install the A/C belt tensioner bolts.

Tighten

Tighten the bolts to 50 N·m (37 lb ft).

3. Install the A/C drive belt. Refer to *Drive Belt Replacement - Air Conditioning*.



678806

Engine Mount Inspection

SIE-ID = 642546 LMD = 20-oct-1999

Notice: SIO-ID = 5167 LMD = 22-may-1996 Broken or deteriorated mounts can cause misalignment and destruction of certain drive train components. When a single mount breaks, the remaining mounts are subjected to abnormally high stresses.

Notice: SIO-ID = 5168 LMD = 22-may-1996 When raising or supporting the engine for any reason, do not use a jack under the oil pan, any sheet metal, or the crankshaft pulley. Due to the small clearance between the oil pan and the oil pump screen, jacking against the oil pan may cause the pan to be bent against the pump screen. This will result in a damaged oil pickup unit.

1. Measure the engine movement at the engine mount in order to check for damage to the rubber portions of the mount.
 - 1.1. Apply the park brake.
 - 1.2. Start the engine.

- 1.3. Firmly apply and hold the primary brakes.
 - 1.4. Have an assistant stand to the side of the vehicle in order to observe for engine movement.
 - 1.5. Slightly load the engine shifting from drive to reverse a few times.
 - 1.6. If the engine moves more than 24 mm (0.945 in) from the at rest position, in either direction, check for loose engine mount bolts.
2. If the engine mount bolt torque is within specifications, check the condition of the engine mount.
 3. Replace the engine mount if any of the following conditions exist:
 - Heat check cracks cover the rubber cushion surface.
 - The rubber cushion is separated from the metal plate of the mount.
 - There is a split through the rubber cushion.

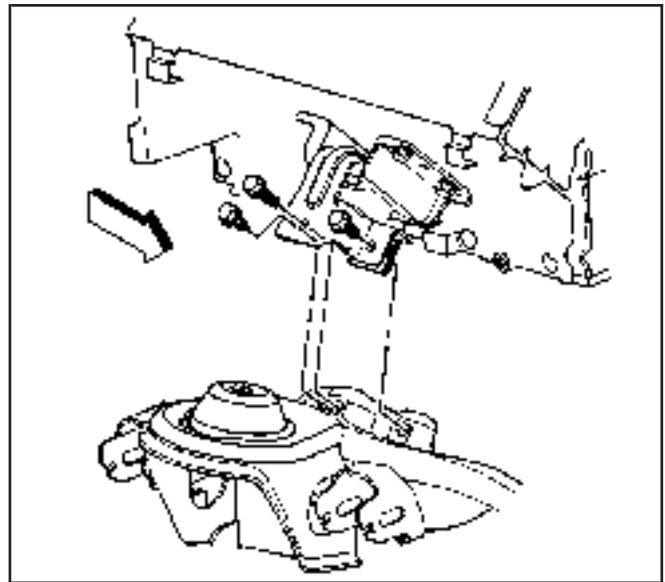
Engine Mount Replacement - Left

SIE-ID = 642547 LMD = 07-jan-2002

Removal Procedure

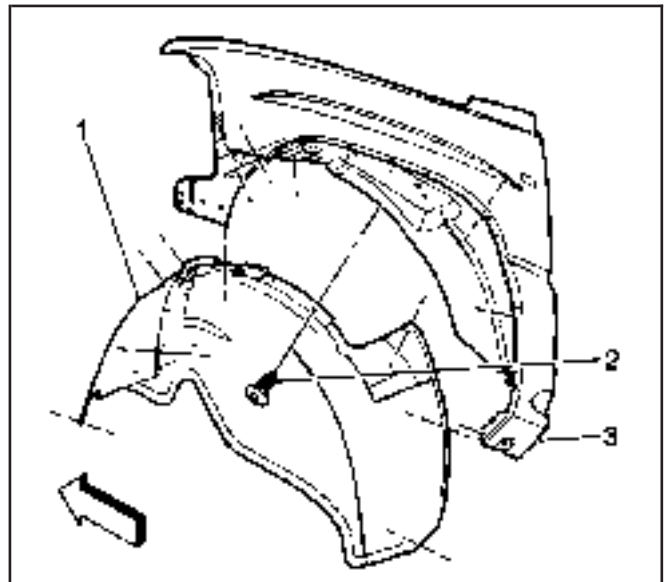
Notice: SIO-ID = 5168 LMD = 22-may-1996 When raising or supporting the engine for any reason, do not use a jack under the oil pan, any sheet metal, or the crankshaft pulley. Due to the small clearance between the oil pan and the oil pump screen, jacking against the oil pan may cause the pan to be bent against the pump screen. This will result in a damaged oil pickup unit.

1. Remove the engine mount-to-engine mount bracket bolts. (Right side shown, left side similar).



307275

2. If vehicle is a 2 wheel drive (2WD), raise the vehicle to a height to work through the front wheelhouse opening.
3. If vehicle is a 4 wheel drive (4WD), raise the vehicle in order to remove the front tires and wheels.
4. Remove the left front tire and wheel. Refer to *Tire and Wheel Removal and Installation* in Tires and Wheels.
5. Remove the wheelhouse inner panel push pin retainers (2).
6. Remove the wheelhouse inner panel (1).

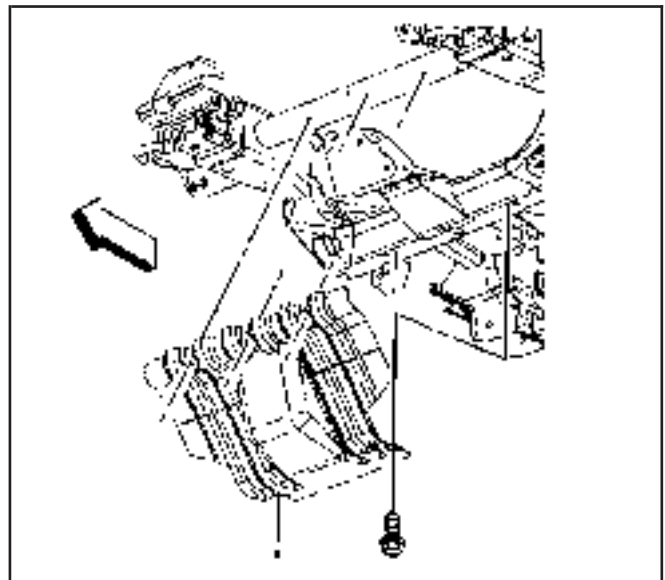


401885

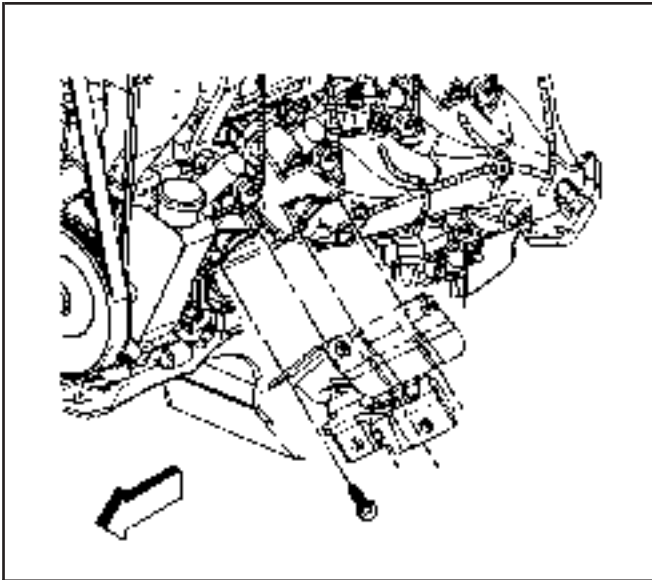
7. Remove the engine shield bolts.
8. Remove the engine shield.

Important: DO NOT raise and/or support the engine by the crankshaft balancer, or oil pan.

9. Raise and suitably support the engine using adjustable (screw type) jack stands.

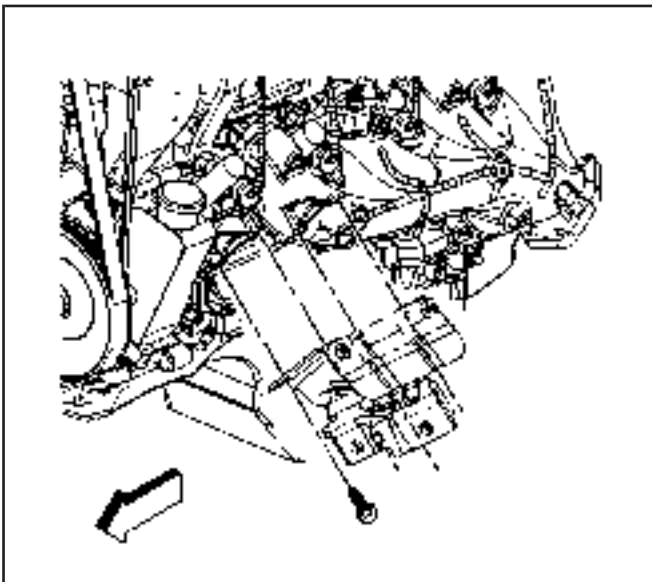


349061



679415

10. Remove the engine mount bolts.
11. For vehicles with 4WD, remove the front propeller shaft. Refer to *Propeller Shaft Replacement - Front* in Propeller Shaft.
12. Remove the left engine mount.



679415

Installation Procedure

1. Position the left engine mount to the engine.

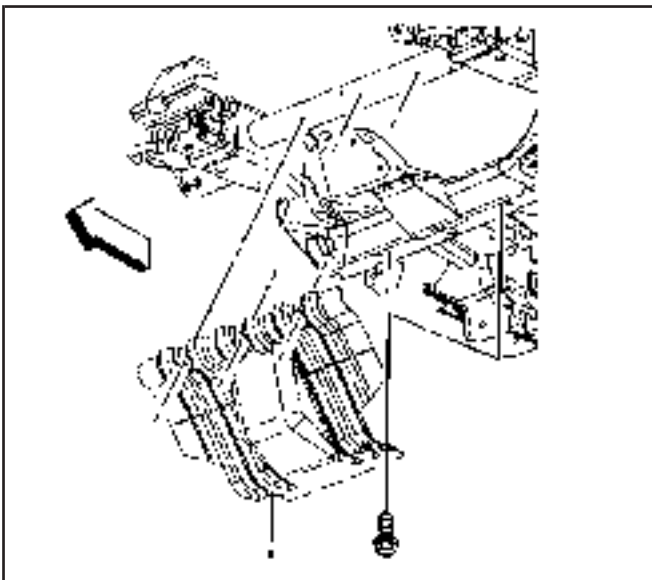
Notice: Refer to *Fastener Notice* in Cautions and Notices.

2. Install the engine mount bolts.

Tighten

Tighten the engine mount bolts to 50 N·m (37 lb ft).

3. Lower the engine.
4. Remove the adjustable jack stands.
5. Install the front propeller shaft. Refer to *Propeller Shaft Replacement - Front* in Propeller Shaft.



349061

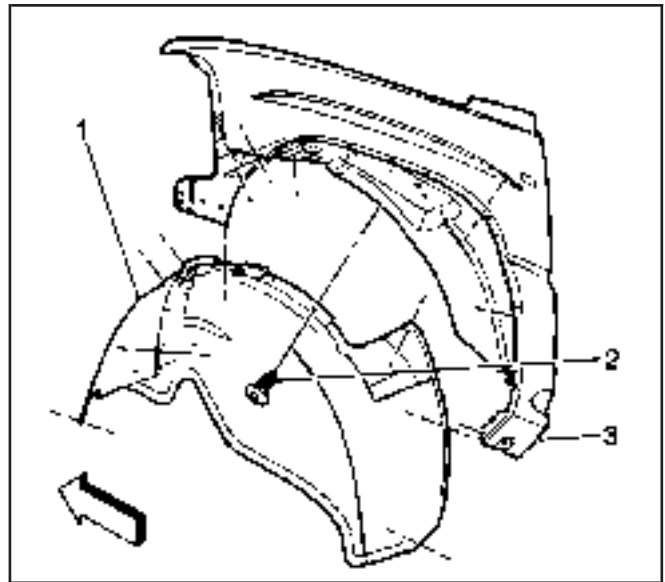
6. Position the engine shield to the vehicle.
7. Install the engine shield bolts.

Tighten

Tighten the engine shield bolts to 20 N·m (15 lb ft).

8. Lower the vehicle.

9. Install the left front tire and wheel. Refer to *Tire and Wheel Removal and Installation* in Tires and Wheels.
10. Install the wheelhouse inner panel push pin retainers (2).
11. Install the wheelhouse inner panel (1).

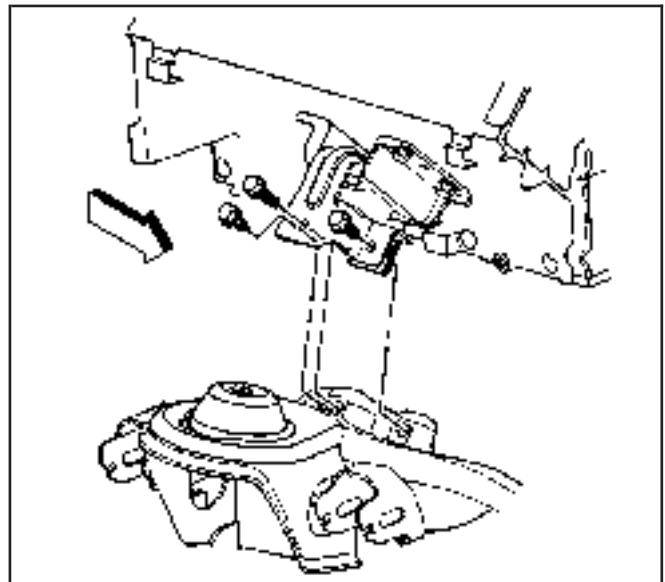


401885

12. Install the engine mount-to-engine mount bracket bolts. (Right side shown, left side similar).

Tighten

Tighten the engine mount-to-engine mount bracket bolts to 65 N·m (48 lb ft).



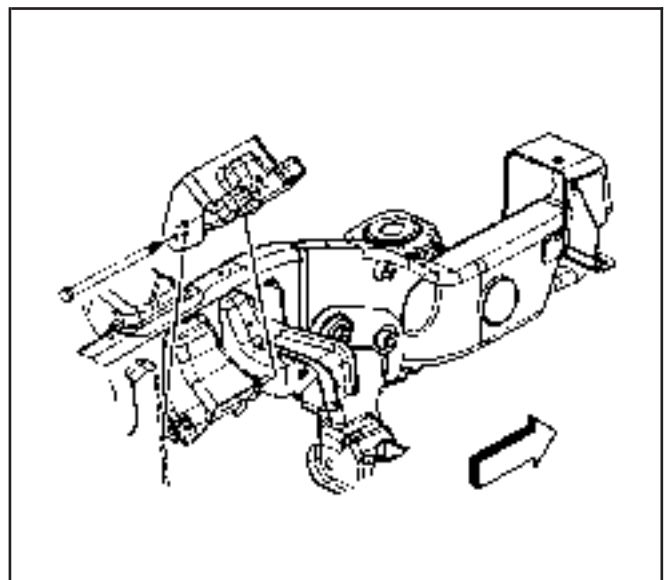
307275

Engine Mount Bracket Replacement - Left

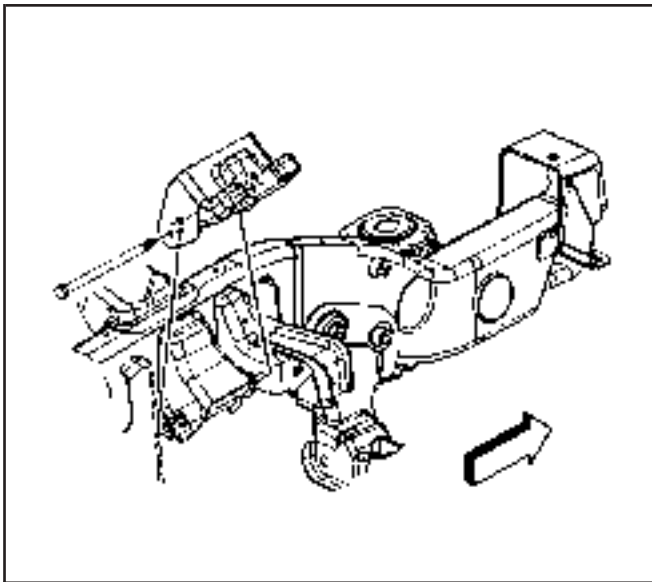
SIE-ID = 686681 LMD = 28-feb-2000

Removal Procedure

1. Remove the engine mount. Refer to *Engine Mount Replacement - Left*.
2. Remove the engine mount bracket bolts.
3. Remove the engine mount bracket.



678843



678843

Installation Procedure

1. Install the engine mount bracket.

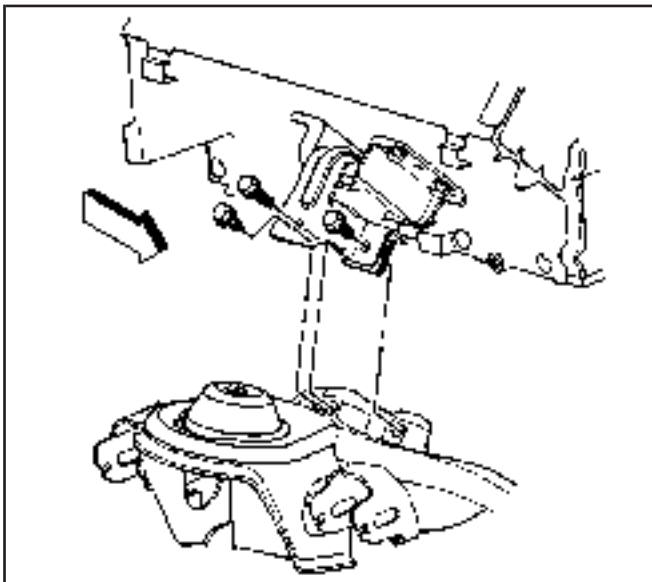
Notice: Refer to *Fastener Notice* in Cautions and Notices.

2. Install the engine mount bracket bolts.

Tighten

Tighten the engine mount bracket bolts to 75 N·m (55 lb ft).

3. Install the engine mount. Refer to *Engine Mount Replacement - Left*.



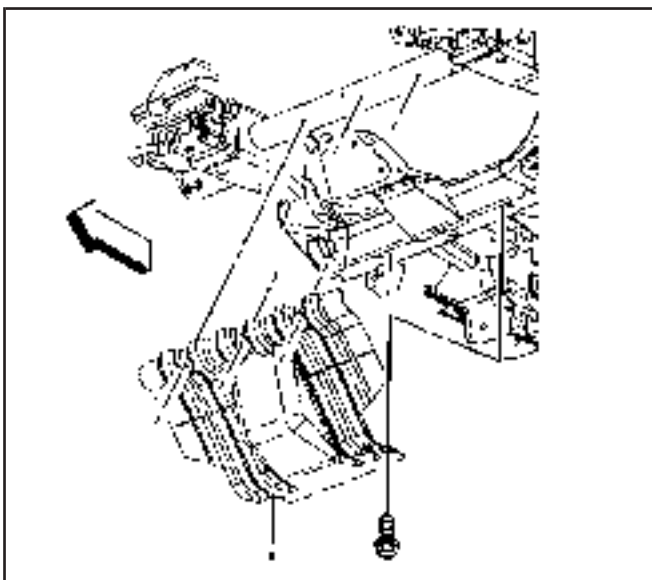
307275

Engine Mount Replacement - Right

SIE-ID = 642548 LMD = 15-nov-2000

Removal Procedure

1. Remove the engine mount-to-engine mount bracket bolts.
2. Raise and suitably support the vehicle. Refer to *Lifting and Jacking the Vehicle* in General Information.



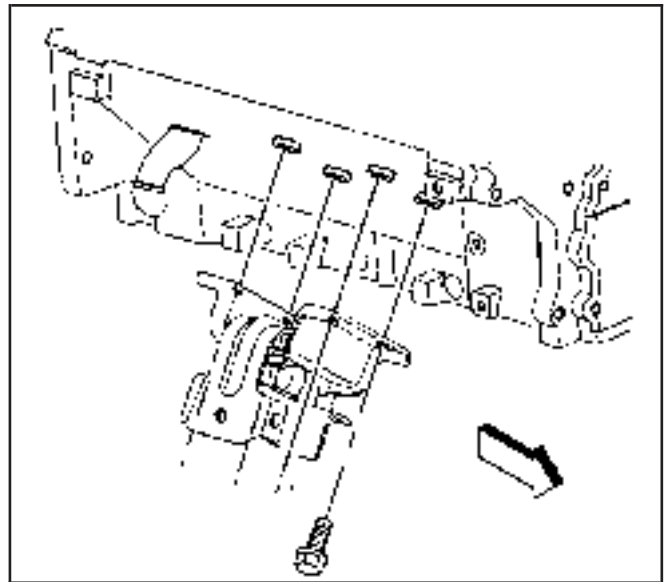
349061

3. Remove the engine shield bolts.
4. Remove the engine shield.
5. Remove the air conditioning (A/C) compressor. Refer to *Compressor Replacement* in Heating, Ventilation, and Air Conditioning.
6. Remove the starter motor. Refer to *Starter Motor Replacement (4.8L, 5.3L, and 6.0L Engines)* or *Starter Motor Replacement (8.1L Engine)* in Engine Electrical.

Important: DO NOT raise and/or support the engine by the crankshaft balancer, or oil pan.

7. Raise and suitably support the engine using adjustable (screw type) jack stands.

8. Remove the engine mount bolts.
9. Remove the right engine mount.



307279

Installation Procedure

1. Position the right engine mount to the engine.

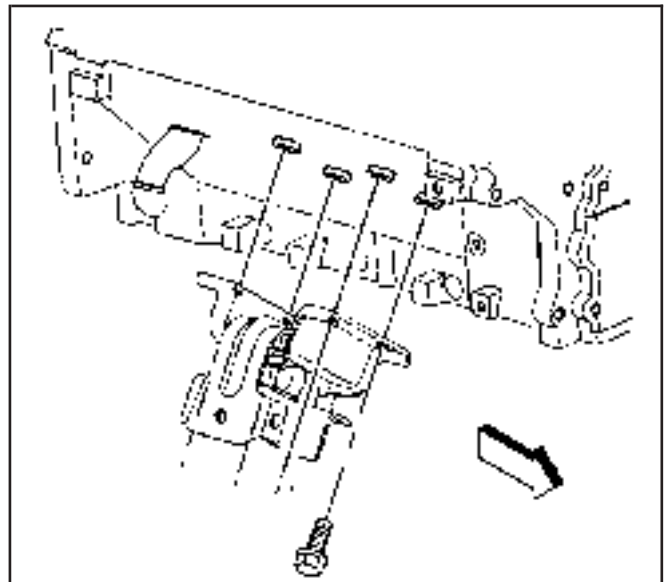
Notice: Refer to *Fastener Notice* in Cautions and Notices.

2. Install the engine mount bolts.

Tighten

Tighten the engine mount bolts to 50 N·m (37 lb ft).

3. Lower the engine.
4. Remove the adjustable jack stands.
5. Install the starter motor. Refer to *Starter Motor Replacement (4.8L, 5.3L, and 6.0L Engines)* or *Starter Motor Replacement (8.1L Engine)* in Engine Electrical.
6. Install the A/C compressor. Refer to *Compressor Replacement* in Heating, Ventilation, and Air Conditioning.



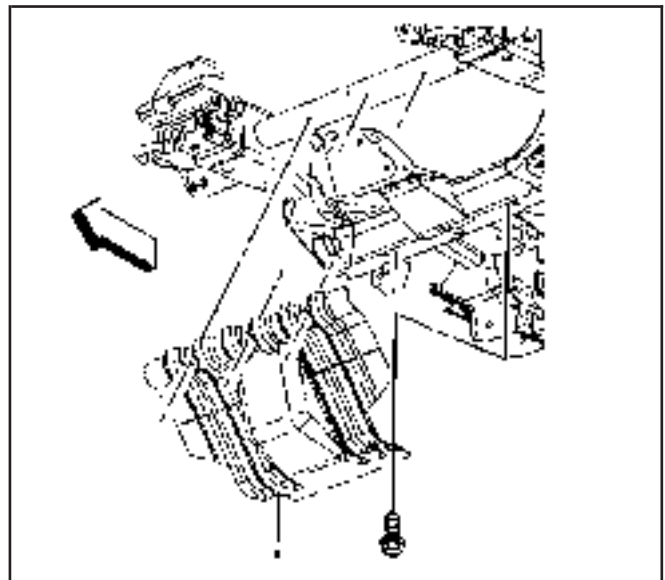
307279

7. Position the engine shield to the vehicle.
8. Install the engine shield bolts.

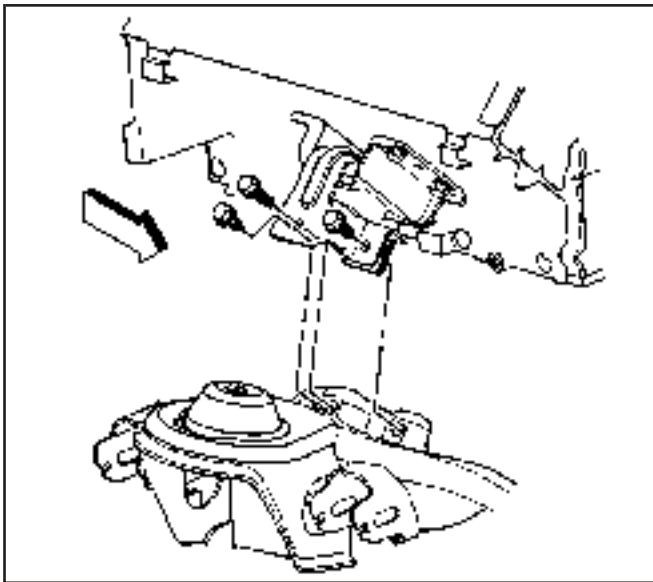
Tighten

Tighten the engine shield bolts to 20 N·m (15 lb ft).

9. Lower the vehicle.



349061

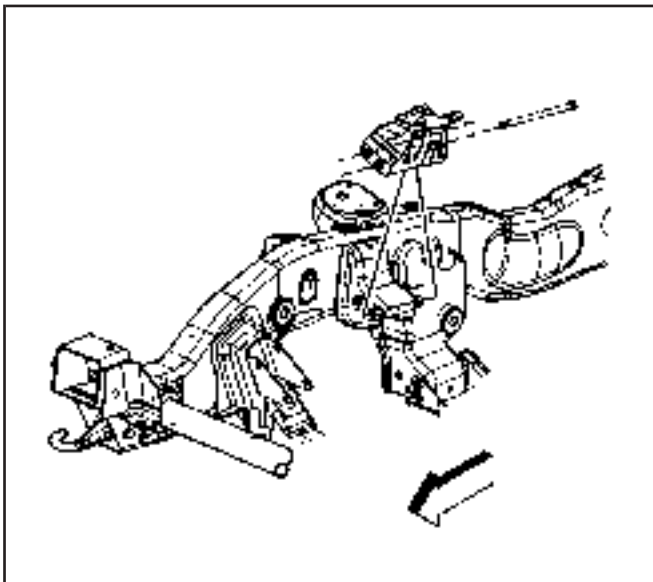


307275

10. Install the engine mount-to-engine mount bracket bolts.

Tighten

Tighten the engine mount-to-engine mount bracket bolts to 65 N·m (48 lb ft).



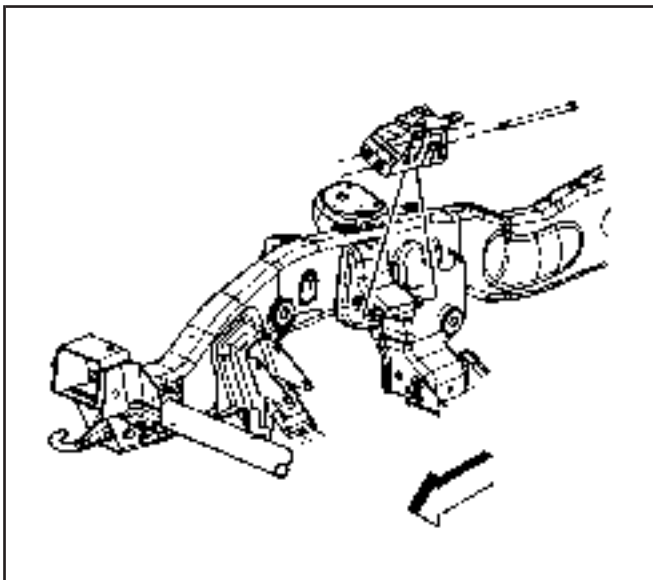
678846

Engine Mount Bracket Replacement - Right

SIE-ID = 686682 LMD = 28-feb-2000

Removal Procedure

1. Remove the engine mount. Refer to *Engine Mount Replacement - Right*.
2. Remove the engine mount bracket bolts.
3. Remove the engine mount bracket.



678846

Installation Procedure

1. Install the engine mount bracket.

Notice: Refer to *Fastener Notice* in Cautions and Notices.

2. Install the engine mount bracket bolts.

Tighten

Tighten the engine mount bracket bolts to 75 N·m (55 lb ft).

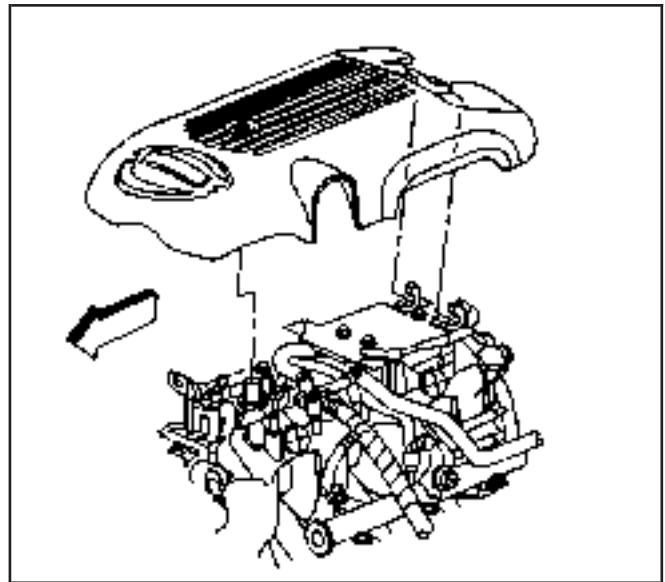
3. Install the engine mount. Refer to *Engine Mount Replacement - Right*.

Engine Sight Shield Replacement (4.8L, 5.3L, and 6.0L (RPO LQ4))

SIE-ID = 824711 LMD = 19-mar-2002

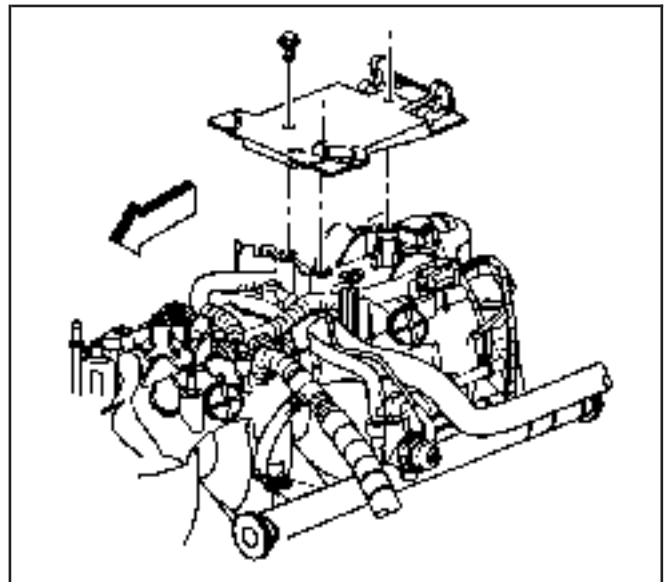
Removal Procedure

1. Loosen the intake manifold sight shield bolt.
2. Remove the sight shield from the sight shield retainer.



832094

3. Remove the sight shield retainer bolts and the retainer, if required.



832095

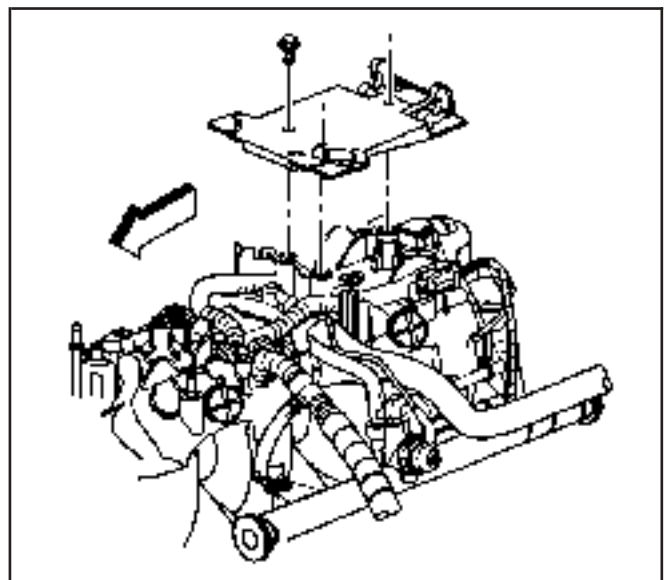
Installation Procedure

Notice: Refer to *Fastener Notice* in Cautions and Notices.

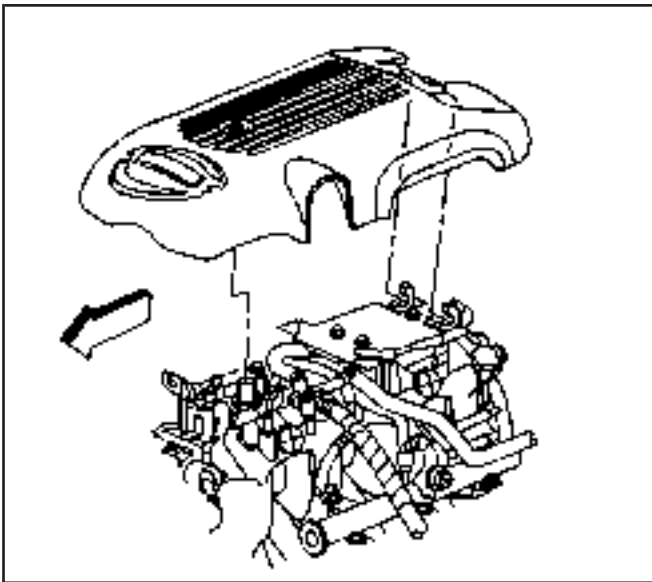
1. Install the sight shield retainer and the bolts, if required.

Tighten

Tighten the bolts to 5 N·m (44 lb in).



832095



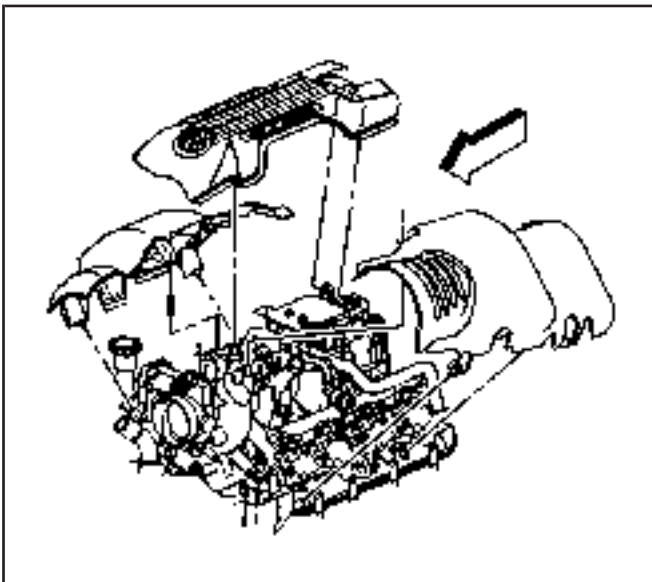
832094

Notice: SIO-ID = 310596 LMD = 14-apr-1998 Use care when installing the engine sight shield to avoid contacting the manifold absolute pressure (MAP) sensor wire harness connector. Loss of engine performance or engine damage may result.

2. Install the intake manifold sight shield to the retainer.

Tighten

Tighten the bolt to 10 N-m (89 lb in).



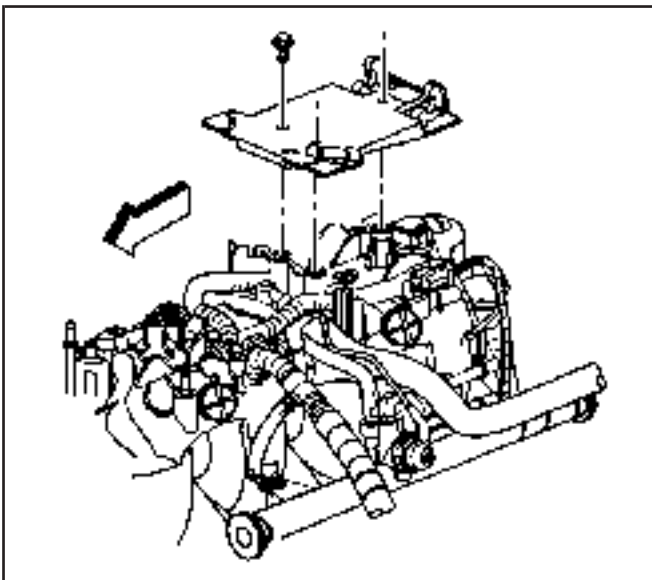
832097

Engine Sight Shield Replacement (6.0L (RPO LQ9))

SIE-ID = 824713 LMD = 19-mar-2002

Removal Procedure

1. Loosen the intake manifold sight shield bolt.
2. Remove the sight shield from the sight shield retainer.
3. Loosen the left fuel rail cover bolts.
4. Remove the left fuel rail cover.
5. Remove the surge tank/heater hoses from the clip on the right fuel rail cover.
6. Loosen the right fuel rail cover bolts.
7. Remove the right fuel rail cover.
8. Remove the sight shield retainer bolts and retainer, if required.



832095

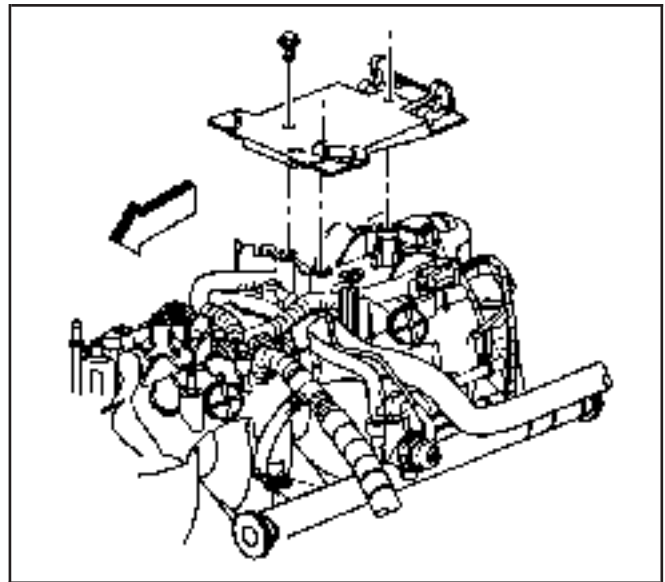
Installation Procedure

Notice: Refer to *Fastener Notice* in Cautions and Notices.

1. Install the sight shield retainer and bolts, if required.

Tighten

Tighten the bolts to 5 N·m (44 lb in).



832095

2. Install the right fuel rail cover.
3. Tighten the right fuel rail cover bolts.

Tighten

Tighten the bolts to 9 N·m (80 lb in)

4. Install the surge tank/heater hoses to the clip on the right fuel rail cover.
5. Install the left fuel rail cover.
6. Tighten the left fuel rail cover bolts.

Tighten

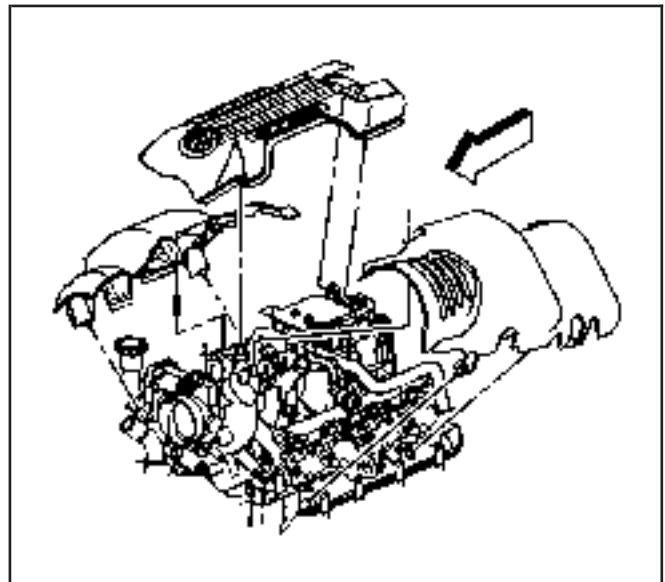
Tighten the bolts to 9 N·m (80 lb in)

Notice: SIO-ID = 310596 LMD = 14-apr-1998 Use care when installing the engine sight shield to avoid contacting the manifold absolute pressure (MAP) sensor wire harness connector. Loss of engine performance or engine damage may result.

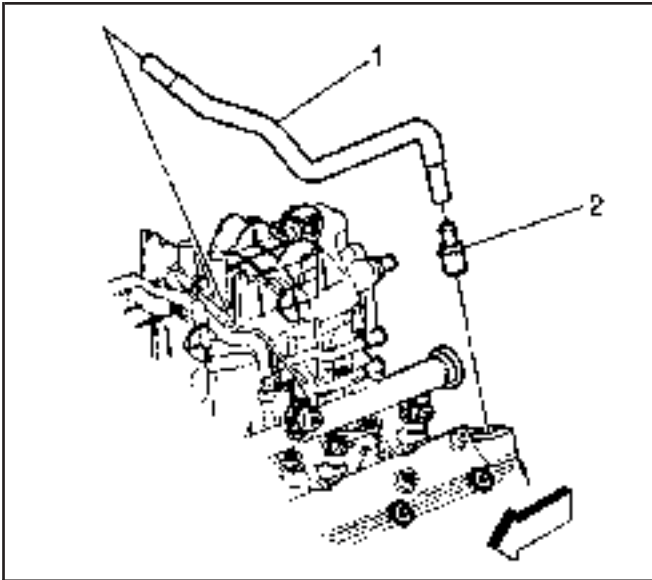
7. Install the sight shield to the sight shield retainer.
8. Tighten the intake manifold sight shield bolt.

Tighten

Tighten the bolt to 9 N·m (80 lb in)



832097



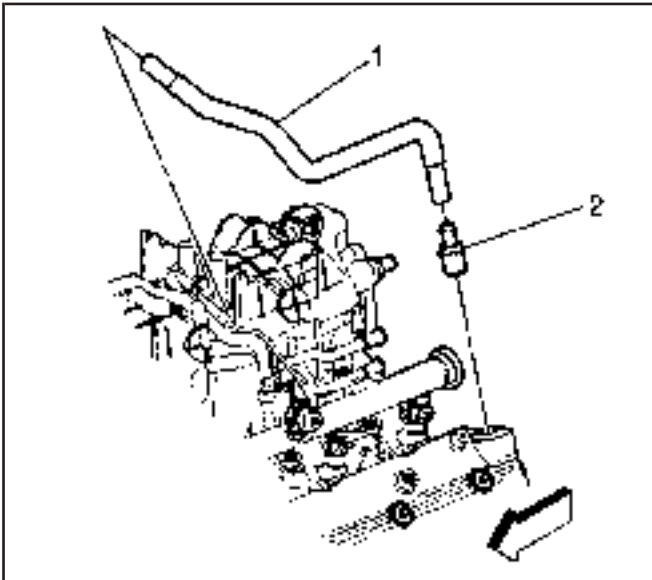
260078

Positive Crankcase Ventilation (PCV) Valve Replacement

SIE-ID = 696323 LMD = 11-oct-2000

Removal Procedure

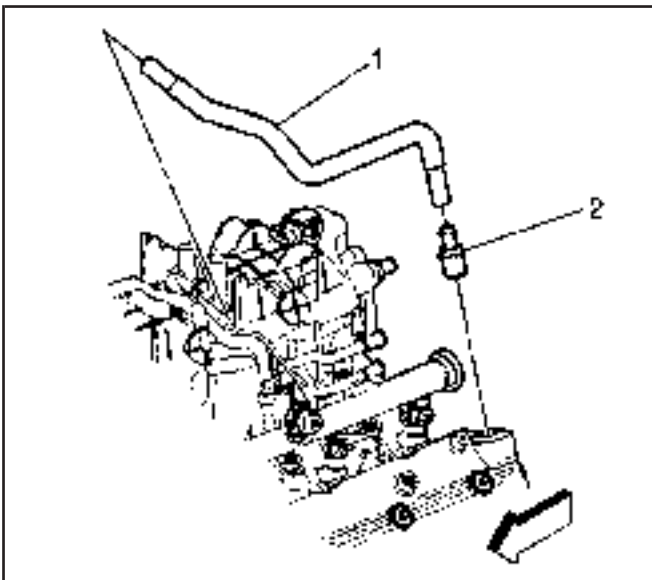
1. Remove the engine sight shield, if required. Refer to *Engine Sight Shield Replacement (4.8L, 5.3L, and 6.0L (RPO LQ4))* or *Engine Sight Shield Replacement (6.0L (RPO LQ9))*.
2. Remove the positive crankcase ventilation (PCV) tube (1) from the rocker arm cover.
3. Remove the PCV valve (2) from the PCV tube (1).



260078

Installation Procedure

1. Install a new PCV valve (2) to the PCV tube (1).
2. Install the PCV tube (1) to the rocker arm cover.
3. Install the engine sight shield, if required. Refer to *Engine Sight Shield Replacement (4.8L, 5.3L, and 6.0L (RPO LQ4))* or *Engine Sight Shield Replacement (6.0L (RPO LQ9))*.



260078

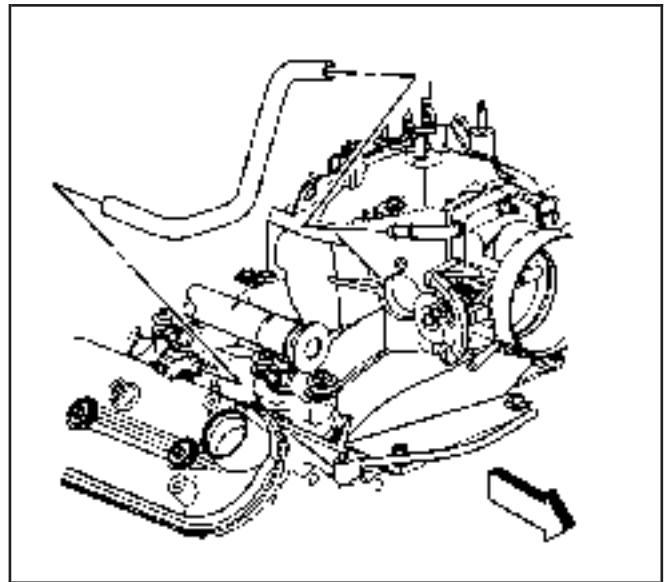
Crankcase Ventilation Hoses/Pipes Replacement

SIE-ID = 824715 LMD = 28-jan-2002

Removal Procedure

1. Remove the engine sight shield. Refer to *Engine Sight Shield Replacement (4.8L, 5.3L, and 6.0L (RPO LQ4))* or *Engine Sight Shield Replacement (6.0L (RPO LQ9))*.
2. Remove the positive crankcase ventilation (PCV) tube (1) from the intake manifold and valve rocker arm cover.
3. Remove the PCV valve (2) from the PCV tube (1).

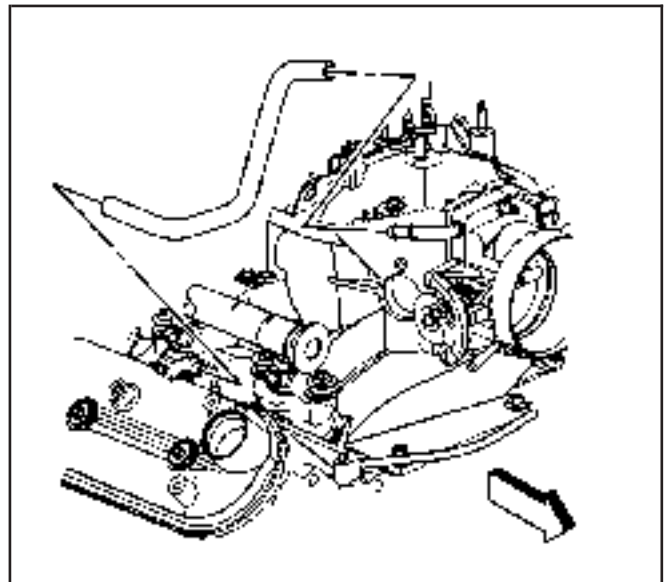
4. Remove the vent hose from the throttle body and the valve rocker arm cover.
5. Replace the hose/tube as necessary.



647795

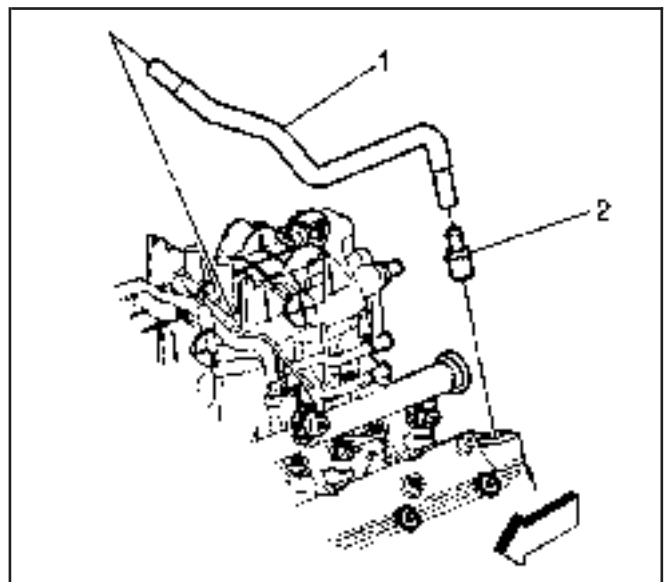
Installation Procedure

1. Install the hose/tube as necessary.
2. Install the vent hose to the throttle body and the valve rocker arm cover.

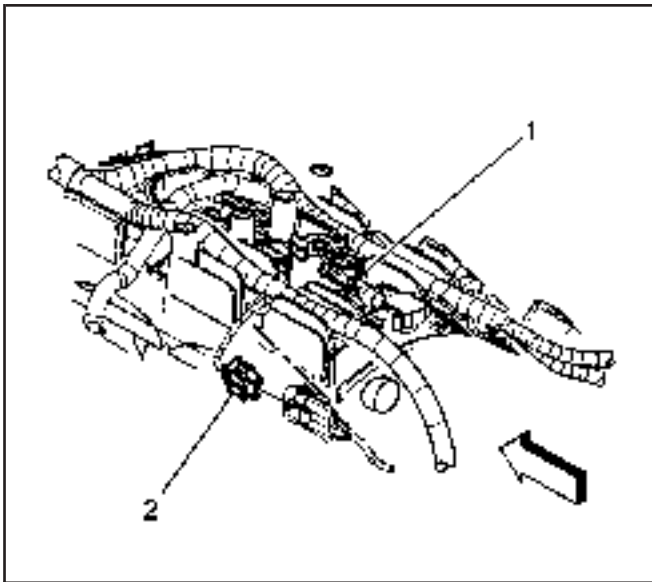


647795

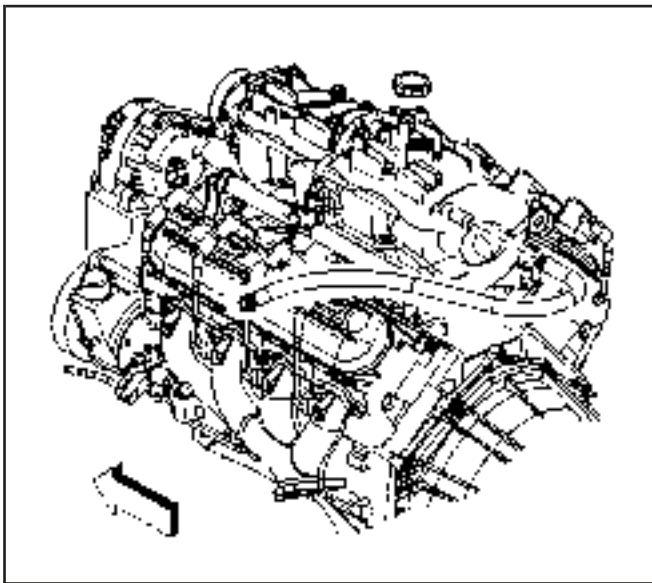
3. Install the PCV valve (2) to the tube (1).
4. Install the PCV tube (1) to the intake manifold and valve rocker arm cover.
5. Install the engine sight shield. Refer to *Engine Sight Shield Replacement (4.8L, 5.3L, and 6.0L (RPO LQ4))* or *Engine Sight Shield Replacement (6.0L (RPO LQ9))*.



260078



679510



382483

Intake Manifold Replacement

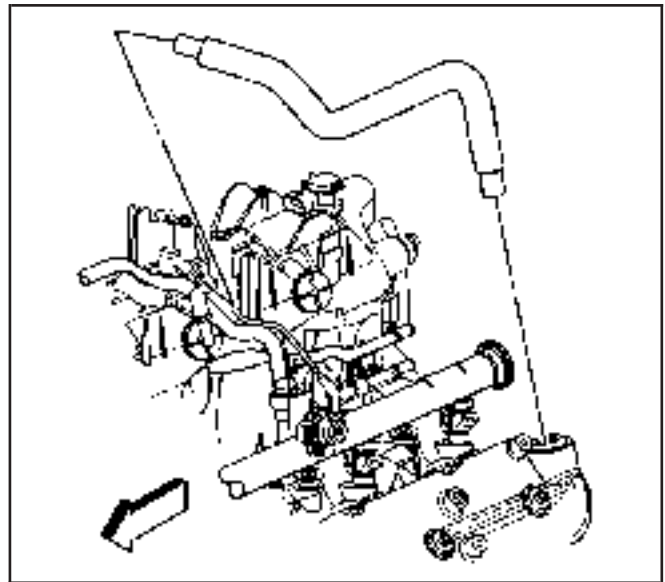
SIE-ID = 824716 LMD = 16-may-2002

Removal Procedure

Important: The intake manifold, throttle body, fuel rail, and injectors may be removed as a complete assembly. If not servicing the individual components, remove the manifold as a complete assembly.

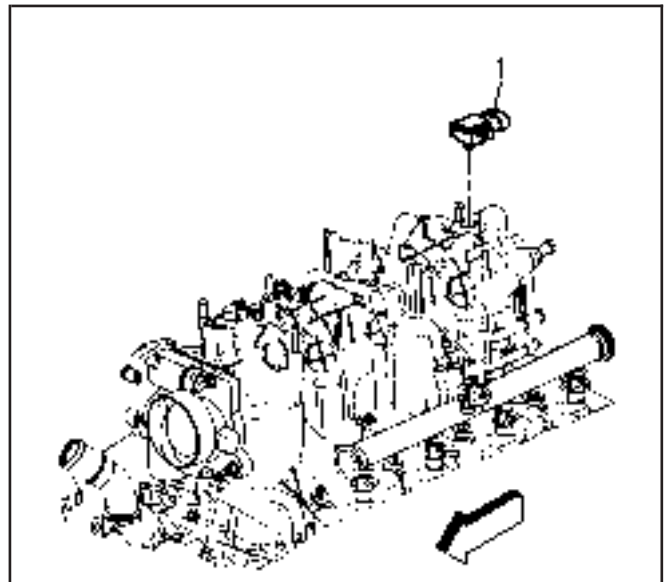
1. Remove the throttle body. Refer to *Throttle Body Assembly Replacement* in Engine Controls – 4.8L, 5.3L, and 6.0L.
2. Remove the fuel injectors. Refer to *Fuel Injector Replacement* in Engine Controls – 4.8L, 5.3L, and 6.0L.
3. Disconnect the following electrical connectors:
 - The manifold absolute pressure (MAP) sensor (1)
 - The knock sensor (2)
4. Remove the knock sensor harness electrical connector from the intake manifold.
5. Set the electrical harness aside.
6. If equipped with vacuum assisted brakes, remove the vacuum brake booster hose from the rear of the intake manifold.

7. Remove the positive crankcase ventilation (PCV) hose with valve.



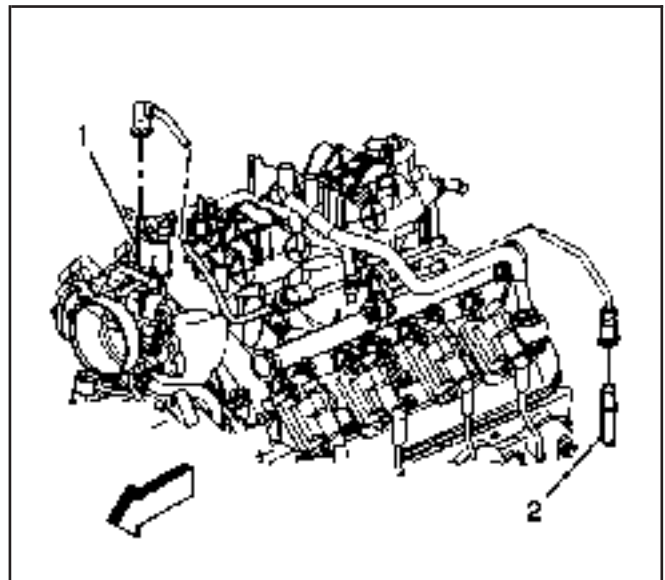
647793

8. Remove the MAP sensor (1) from the intake manifold.

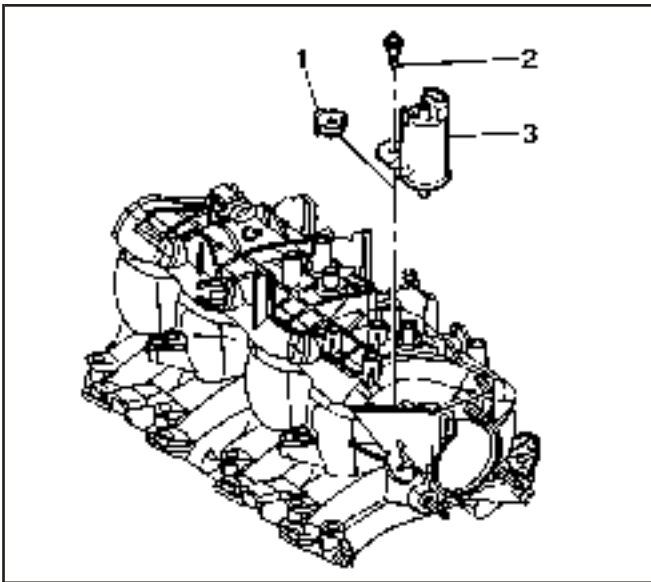


863068

9. Remove the evaporative emission (EVAP) purge solenoid vent tube by performing the following:
 - 9.1. Remove the EVAP tube end from the solenoid (1).
 - 9.2. Remove the EVAP tube end from the vapor pipe (2).

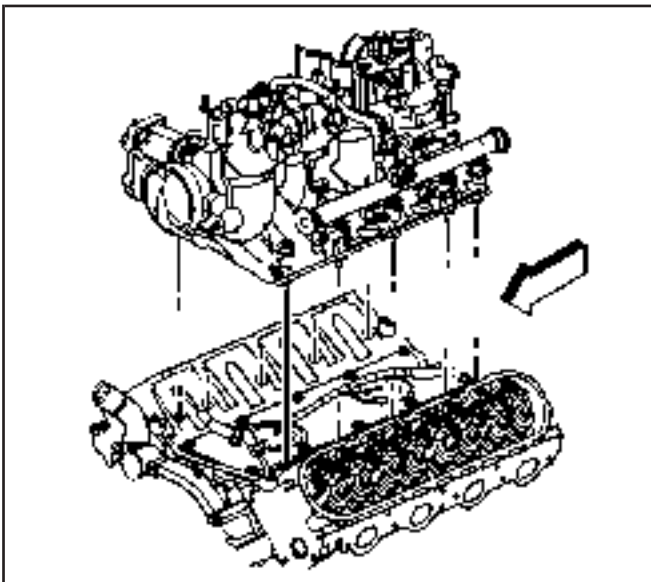


832127



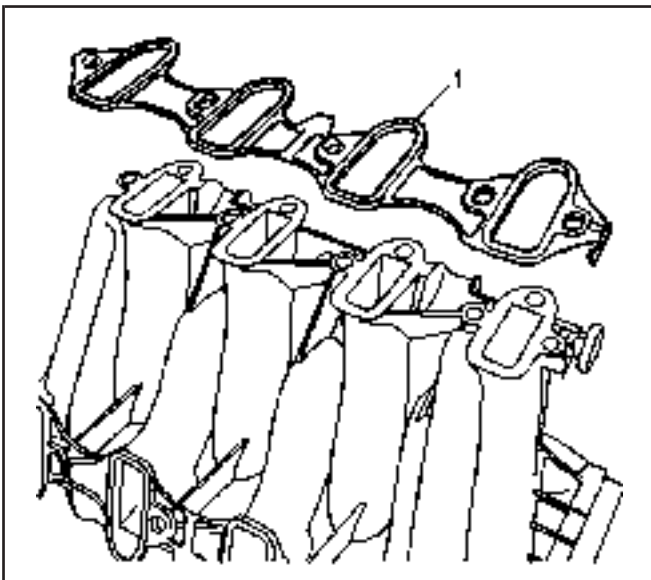
389993

10. Remove the EVAP purge solenoid bolt (2), solenoid (3), and isolator (1) from the intake manifold.



832132

11. Loosen the intake manifold bolts.
12. Remove the intake manifold.

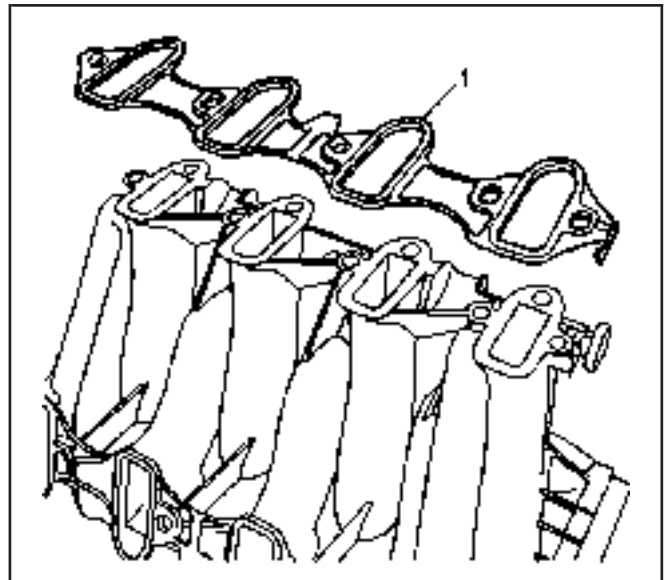


492770

13. Remove the intake manifold gaskets (1) from the intake manifold.
14. Discard the old intake manifold gaskets.
15. If required, clean and inspect the intake manifold. Refer to *Intake Manifold Cleaning and Inspection*.

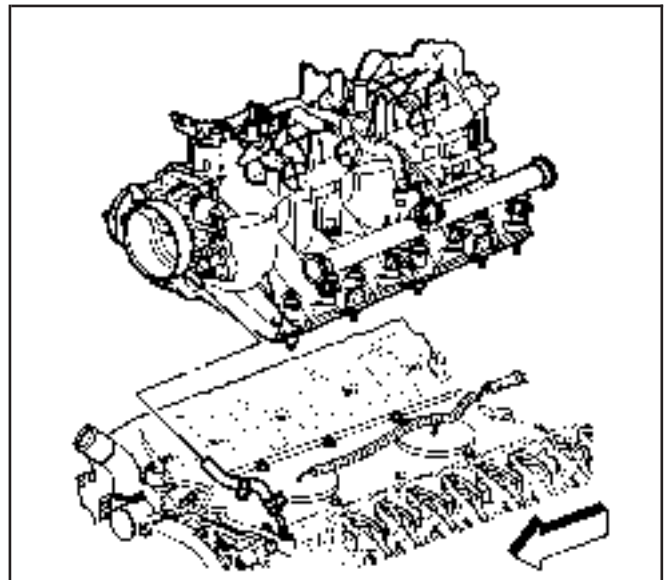
Installation Procedure

1. Install NEW intake manifold gaskets (1) to the intake manifold.



492770

2. Install the intake manifold.
3. Apply a 5 mm (0.20 in) band of threadlock GM P/N 12345382 (Canadian P/N 10953489), or equivalent to the threads of the intake manifold bolts.



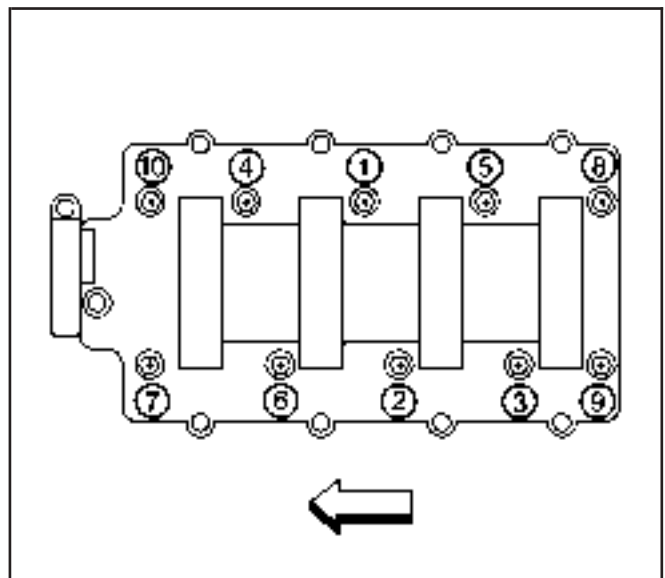
642285

Notice: Refer to *Fastener Notice* in Cautions and Notices.

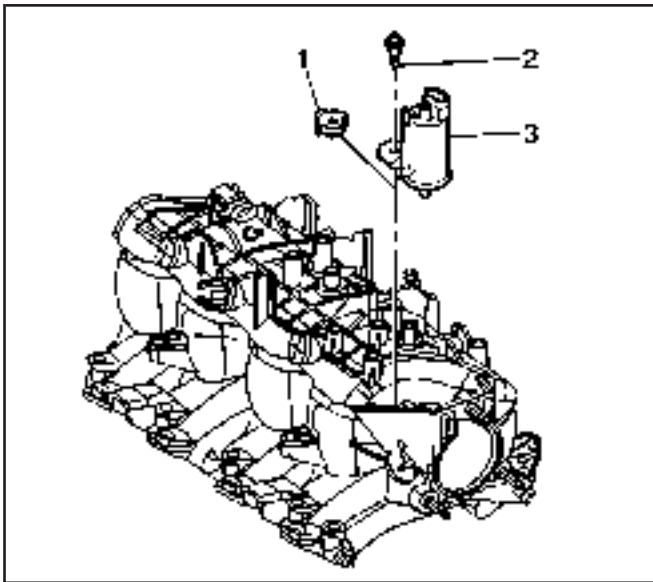
4. Tighten the intake manifold bolts.

Tighten

- 4.1. Tighten the bolts a first pass in sequence to 5 N·m (44 lb in).
- 4.2. Tighten the bolts a final pass in sequence to 10 N·m (89 lb in).



63222

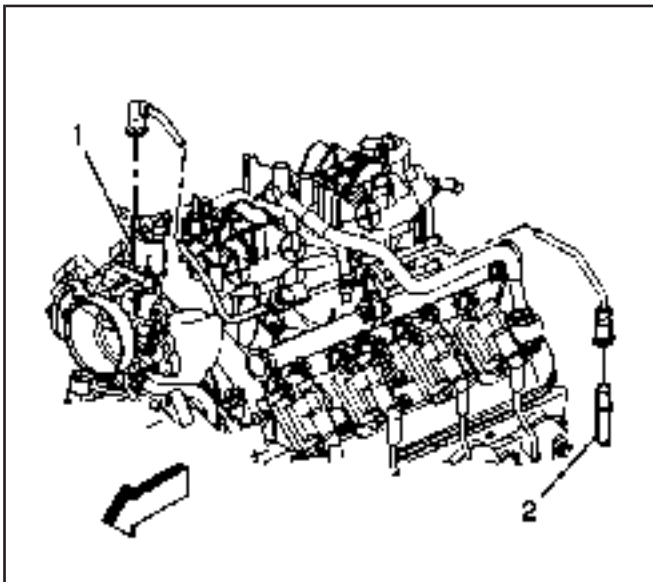


389993

5. Install the EVAP purge solenoid (3), isolator (1), and bolt (2) to the intake manifold.

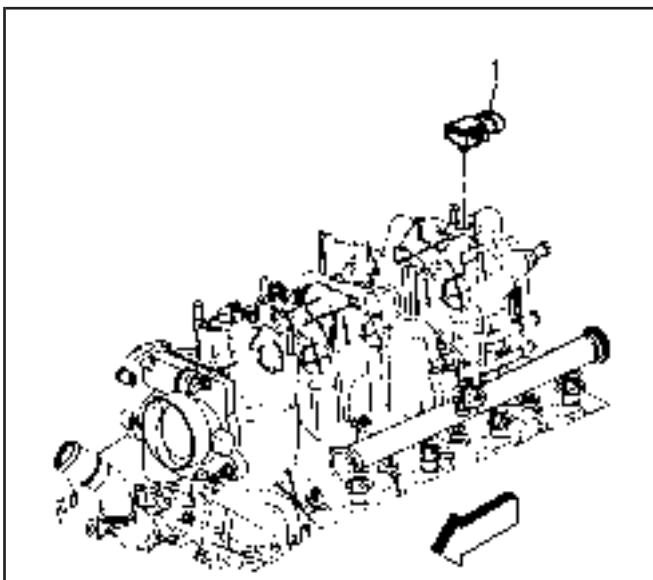
Tighten

Tighten the bolt to 10 N·m (89 lb in).



832127

6. Install the EVAP purge solenoid vent tube to the solenoid (1) and vapor pipe (2).

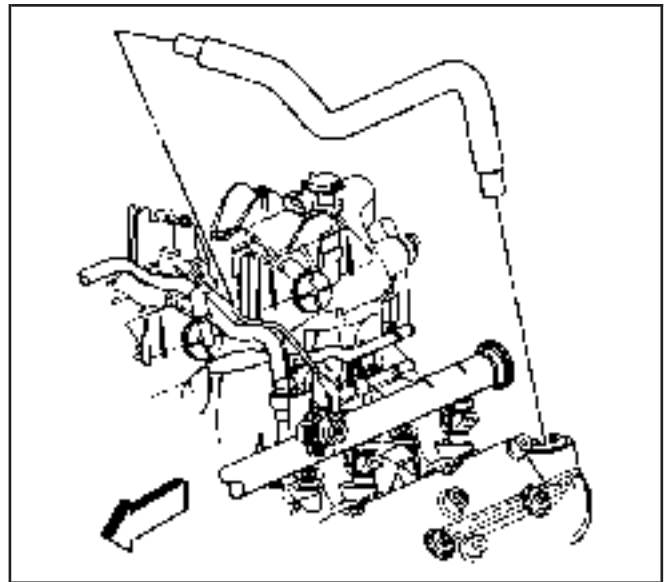


863068

Important: Lightly coat the MAP sensor seal with clean engine oil before installing.

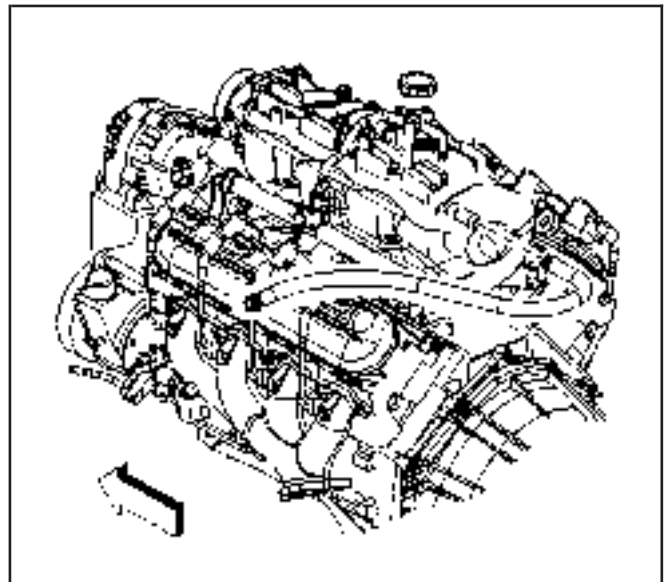
7. Install the MAP sensor (1) to the intake manifold.

8. Install the PCV hose with valve.



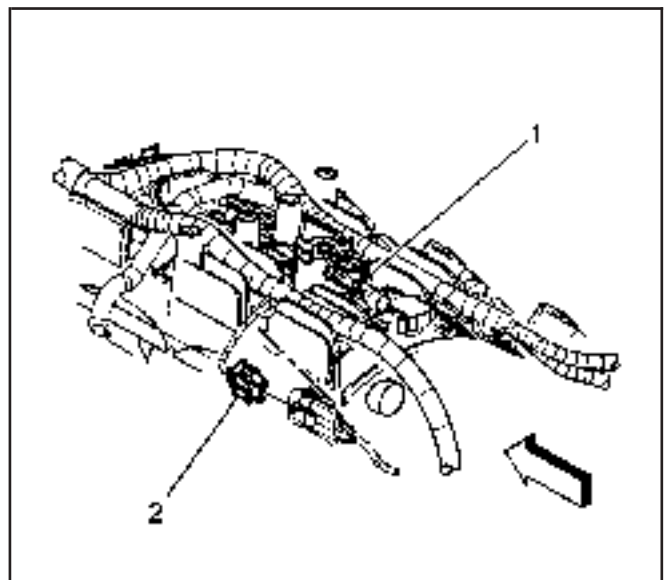
647793

9. If equipped with vacuum assisted brakes, install the vacuum brake booster hose to the rear of the intake manifold.
10. Route the electrical harness into position over the engine.



382483

11. Connect the knock sensor harness electrical connector to the intake manifold.
12. Connect the following electrical connectors.
 - The MAP sensor (1)
 - The knock sensor (2)
13. Install the fuel injectors. Refer to *Fuel Injector Replacement* in Engine Controls – 4.8L, 5.3L, and 6.0L.
14. Install the throttle body. Refer to *Throttle Body Assembly Replacement* in Engine Controls – 4.8L, 5.3L, and 6.0L.



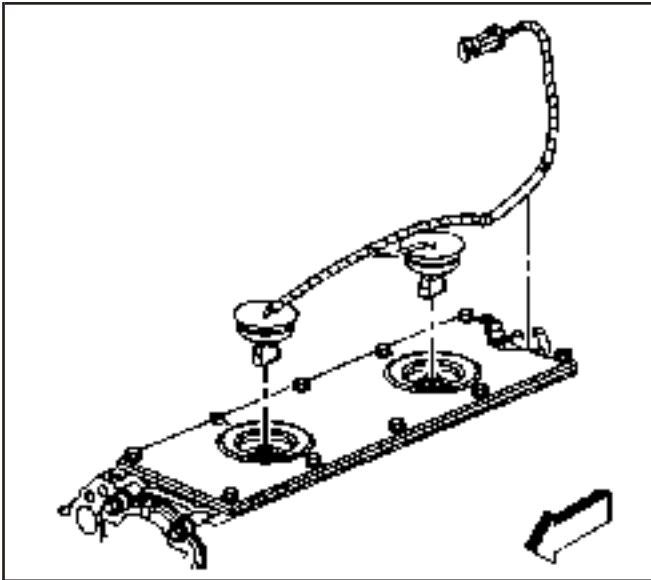
679510

Engine Valley Cover Replacement

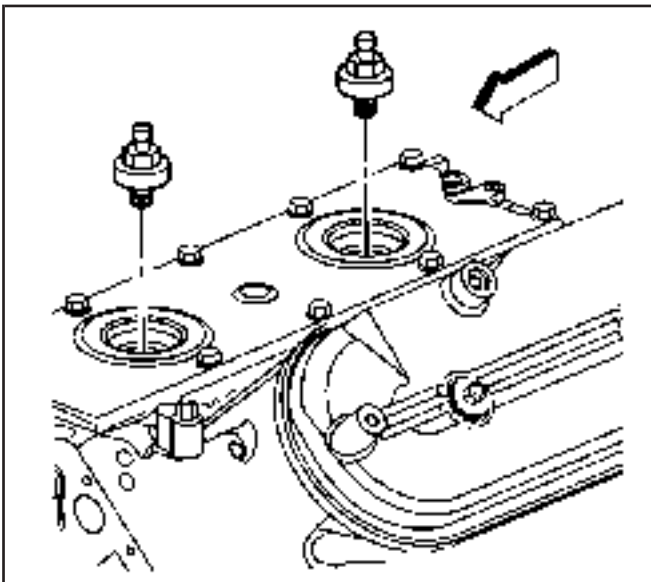
SIE-ID = 824806 LMD = 19-mar-2002

Removal Procedure

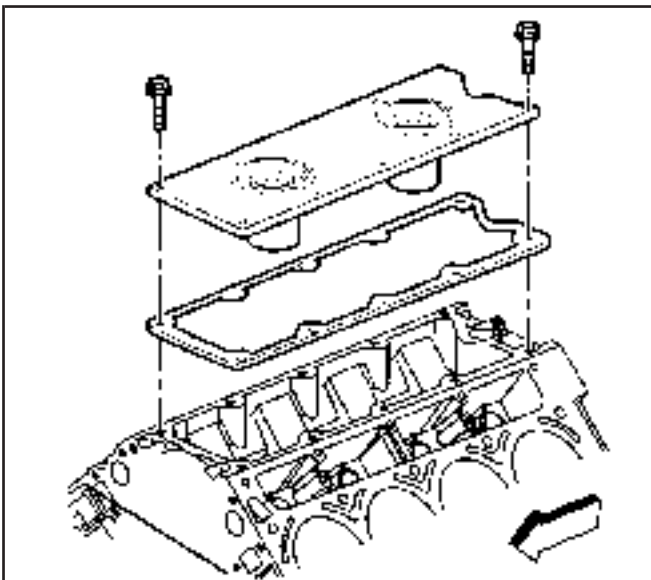
1. Remove the intake manifold. Refer to *Intake Manifold Replacement*.
2. Gently pry up the rubber covers.
3. Disconnect the knock sensor electrical connectors.



832149



309864

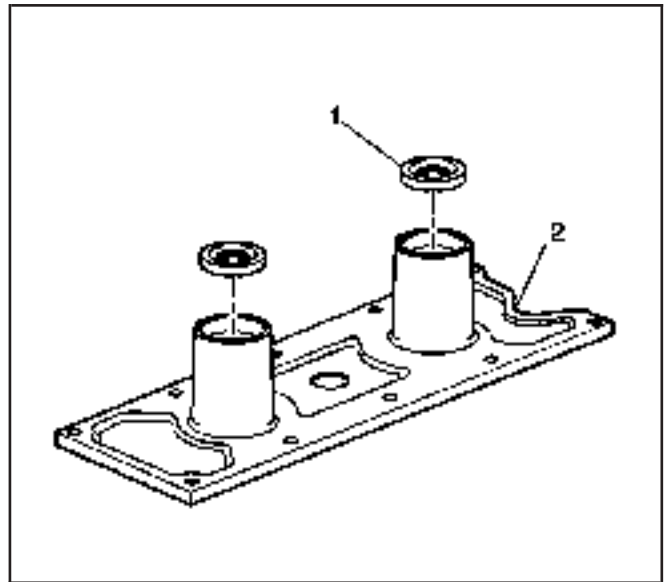


65048

4. Remove the knock sensors.

5. Remove the engine valley cover bolts.
6. Remove the engine valley cover and gasket.
7. Discard the old gasket.

8. Remove the knock sensor oil seals (1) from the cover (2).
9. If required, clean and inspect the engine valley cover. Refer to *Engine Valley Cover Cleaning and Inspection*.

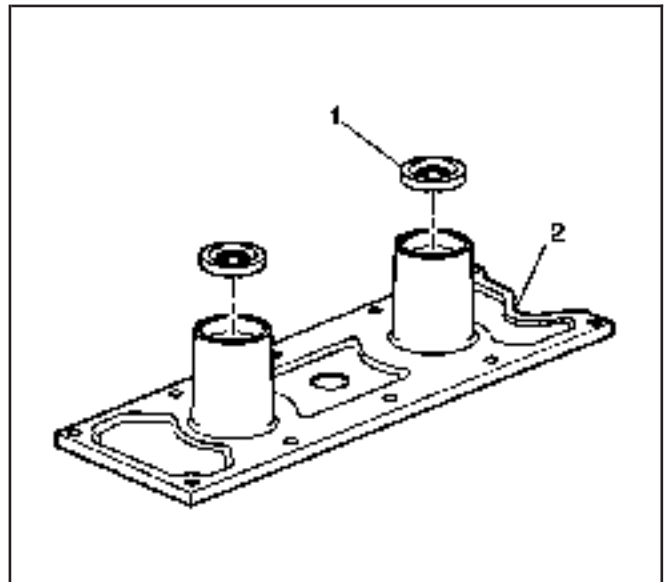


490851

Installation Procedure

Important: All gasket surfaces should be free of oil or other foreign material during assembly.

1. Lubricate the NEW knock sensor seals (1) with clean engine oil.
2. Install the knock sensor oil seals (1) into the engine valley cover (2).



490851

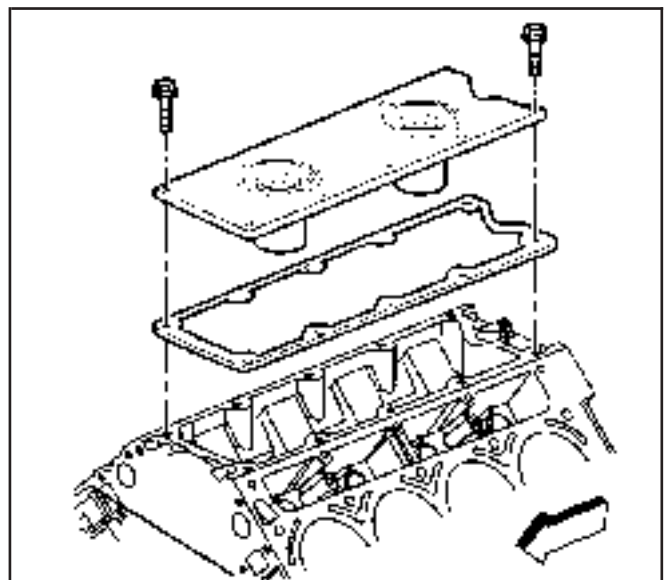
3. Install the engine valley cover with a NEW gasket onto the engine block.

Notice: Refer to *Fastener Notice* in Cautions and Notices.

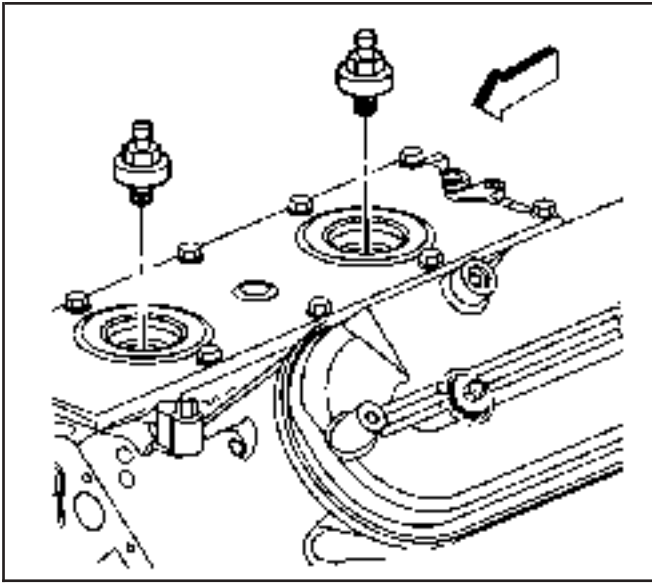
4. Install the engine valley cover bolts.

Tighten

Tighten the bolts to 25 N-m (18 lb ft).



65048

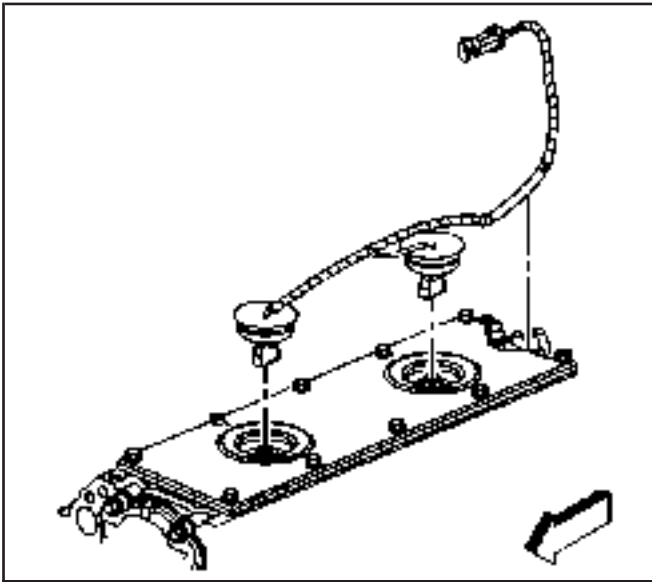


309864

5. Install the knock sensors.

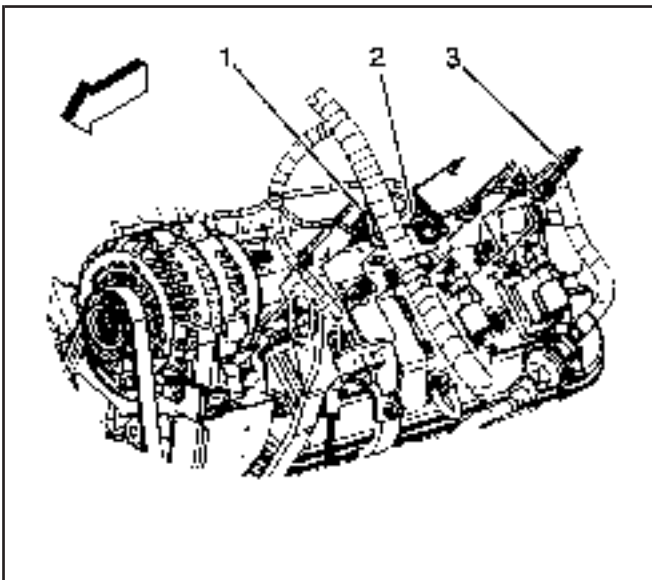
Tighten

Tighten the sensors to 20 N·m (15 lb ft).



832149

6. Connect the knock sensor electrical connectors.
7. Push down on the rubber covers.
8. Install the intake manifold. Refer to *Intake Manifold Replacement*.



679597

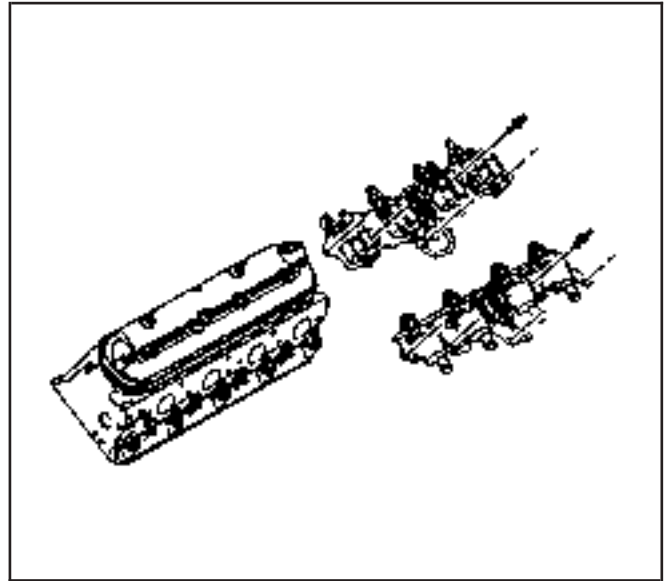
Valve Rocker Arm Cover Replacement - Left

SIE-ID = 824718 LMD = 19-mar-2002

Removal Procedure

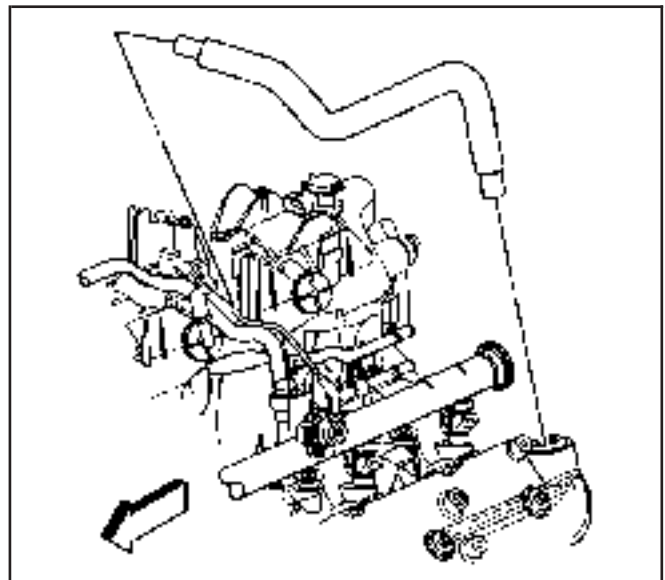
1. Remove the engine sight shield, if required. Refer to *Engine Sight Shield Replacement (4.8L, 5.3L, and 6.0L (RPO LQ4))* or *Engine Sight Shield Replacement (6.0L (RPO LQ9))*.
2. Remove the connector position assurance (CPA) lock.
3. Disconnect the main electrical connector (2) feeding the ignition coils.
4. Remove the harness clips (1).
5. Reposition the engine harness, if necessary.
6. Remove the spark plug wires from the ignition coils.

- Twist each plug wire 1/2 turn.
 - Pull only on the boot in order to remove the wire from the ignition coil.
7. Remove the ignition coil bracket studs.
 8. Remove the ignition bracket.

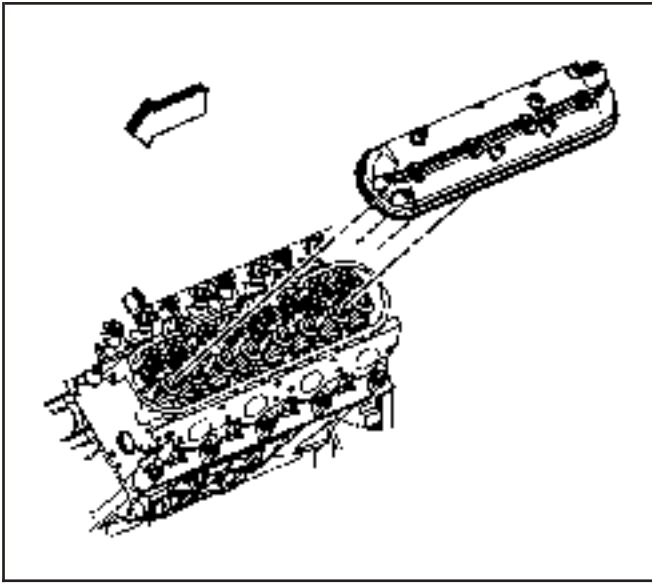


832184

9. Remove the positive crankcase ventilation (PCV) hose.

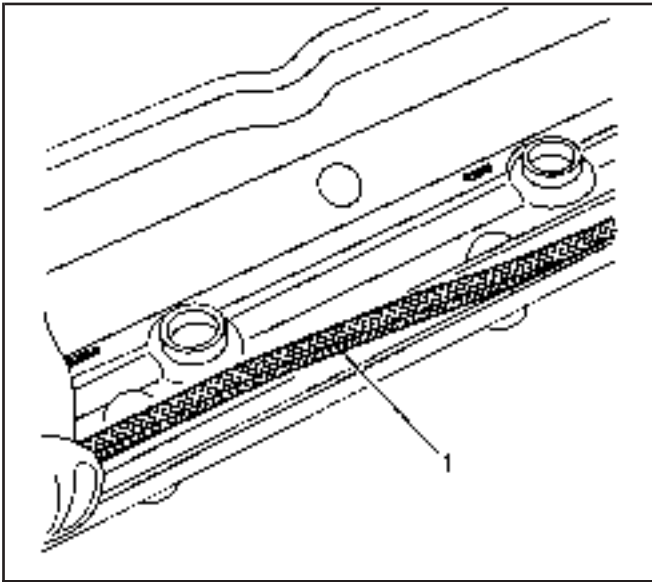


647793



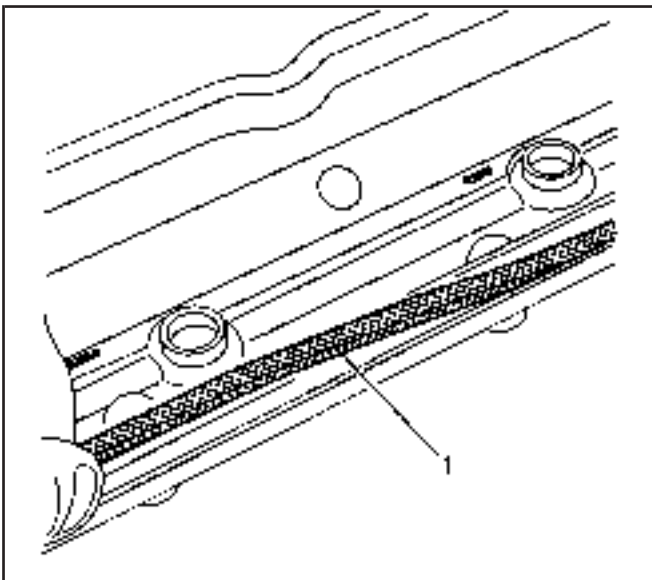
832209

10. Loosen the valve rocker arm cover bolts.
11. Remove the valve rocker arm cover.



490696

12. Remove and discard the old gasket (1).
13. If required, clean and inspect the rocker arm cover. Refer to *Valve Rocker Arm Cover Cleaning and Inspection*.



490696

Installation Procedure

Important:

- All gasket surfaces should be free of oil an/or other foreign material during assembly.
- DO NOT reuse the valve rocker arm cover gasket.
- If the PCV valve grommet has been removed from the rocker cover, install a NEW grommet during assembly.

1. Install a NEW rocker cover gasket (1).

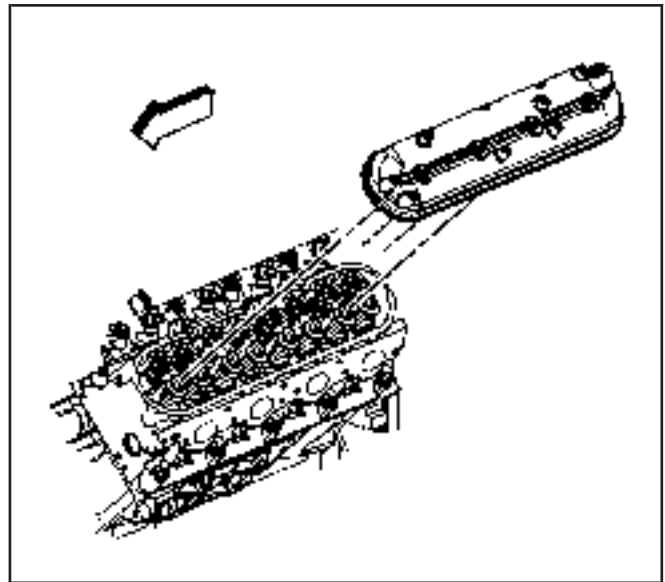
2. Install the valve rocker arm cover.

Notice: Refer to *Fastener Notice* in Cautions and Notices.

3. Tighten the rocker arm cover bolts.

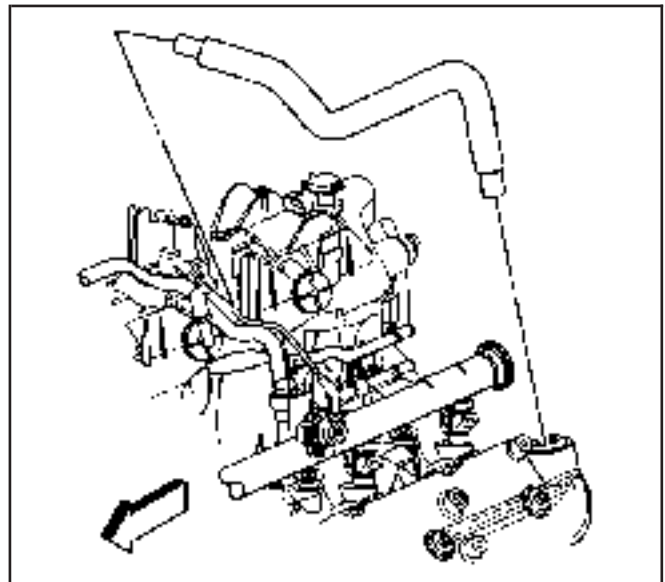
Tighten

Tighten the bolts to 12 N·m (106 lb in).



832209

4. Install the PCV hose to the rocker arm cover.

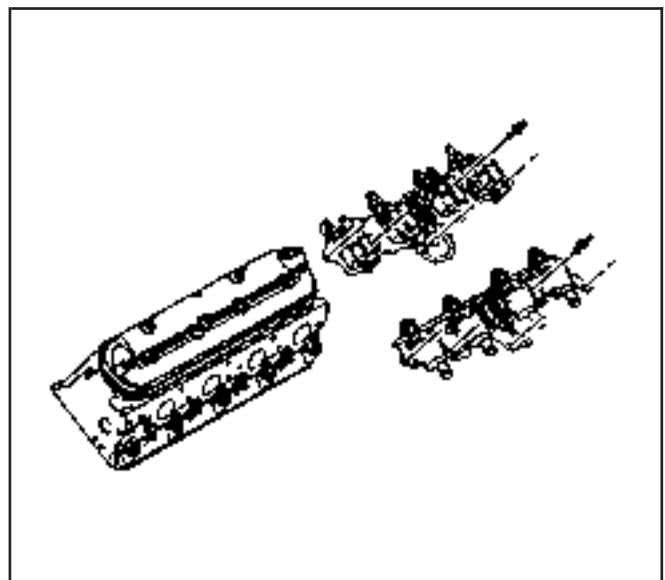


647793

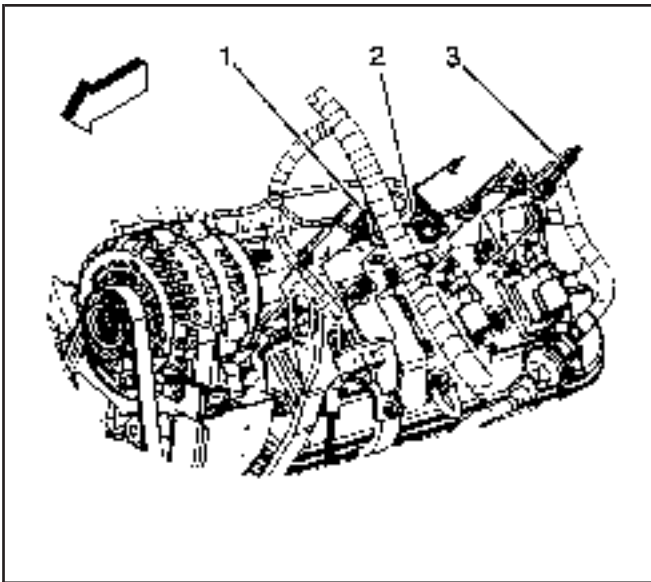
5. Apply threadlock GM P/N 12345382 (Canadian P/N 10953489) or equivalent to the threads of the coil bracket studs.
6. Install the ignition coil bracket.
7. Install the ignition coil bracket studs.

Tighten

Tighten the studs to 12 N·m (106 lb in).

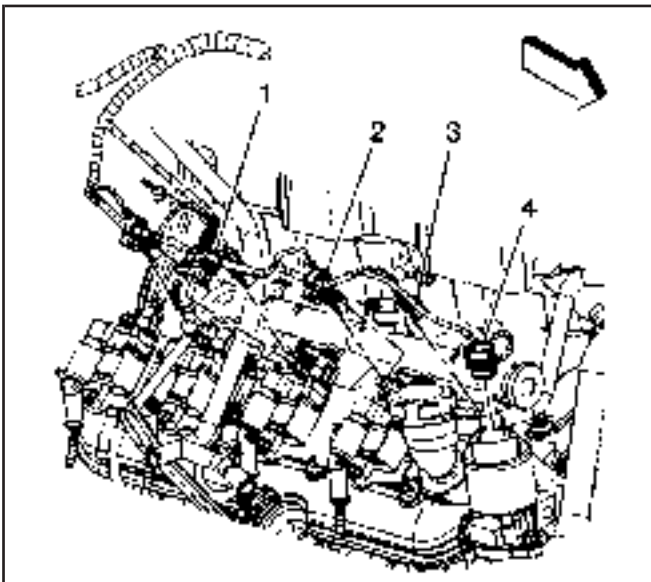


832184



679597

8. Install the spark plug wires to the ignition coils.
9. Position the engine harness, if necessary.
10. Install the harness clips (1).
11. Connect the main electrical connector (2) feeding the ignition coils.
12. Install the CPA lock.
13. Install the engine sight shield, if required. Refer to *Engine Sight Shield Replacement (4.8L, 5.3L, and 6.0L (RPO LQ4))* or *Engine Sight Shield Replacement (6.0L (RPO LQ9))*.



679598

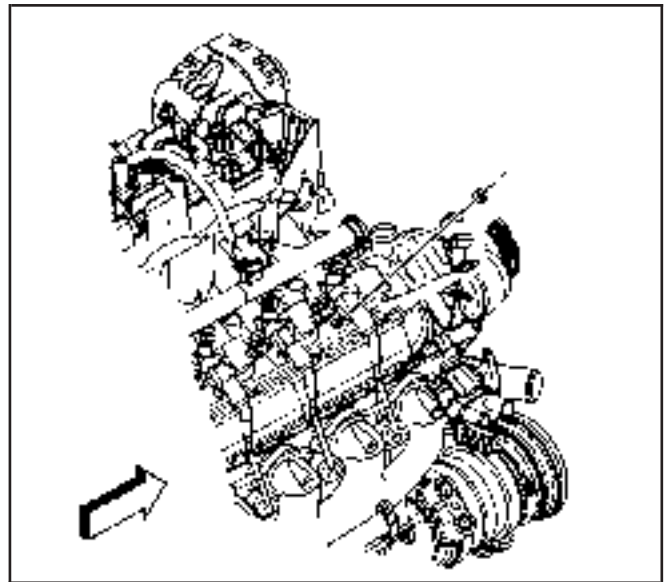
Valve Rocker Arm Cover Replacement - Right

SIE-ID = 824719 LMD = 19-mar-2002

Removal Procedure

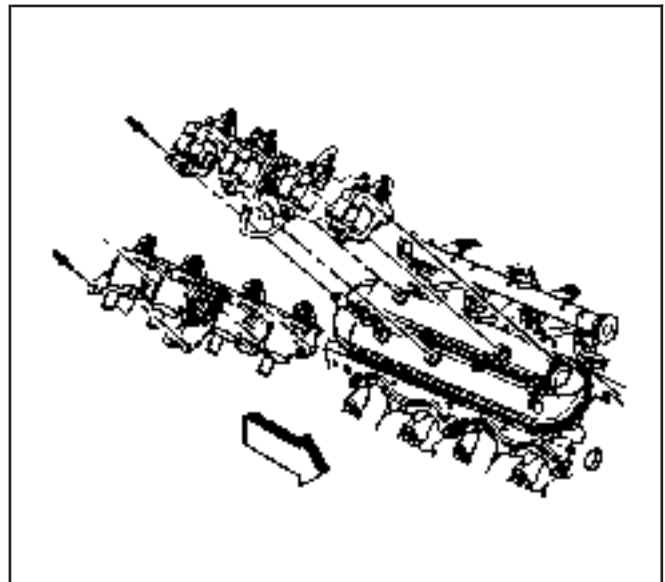
1. Remove the engine sight shield, if required. Refer to *Engine Sight Shield Replacement (4.8L, 5.3L, and 6.0L (RPO LQ4))* or *Engine Sight Shield Replacement (6.0L (RPO LQ9))*.
2. Remove the connector position assurance (CPA) lock.
3. Disconnect the main electrical connector (1) feeding the ignition coils.
4. Remove the harness clips (2).
5. Reposition the engine harness, if necessary.
6. Remove the spark plug wires from the ignition coils.
 - Twist each plug wire 1/2 turn.
 - Pull only on the boot in order to remove the wire from the ignition coil.

7. If equipped with the 4.8L, 5.3L, or 6.0L (LQ4) engine, perform the following:
 - 7.1. Reposition the surge tank/heater hoses from the heater hose bracket.
 - 7.2. Remove the heater hose bracket nut and bracket.



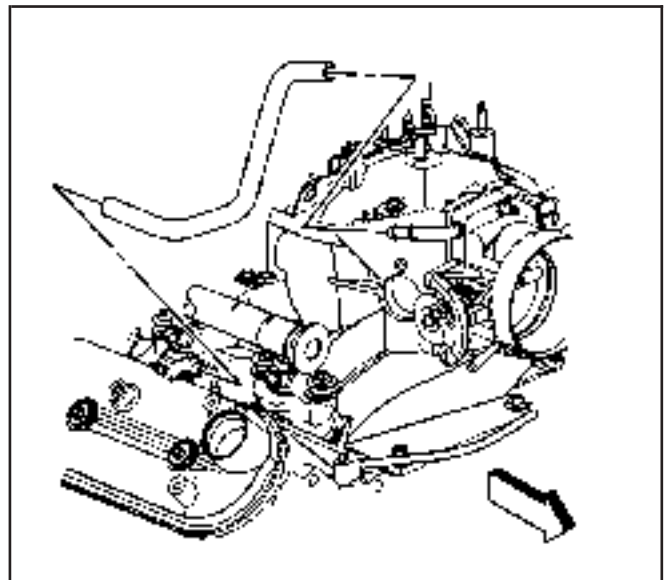
688018

8. Remove the ignition coil bracket studs.
9. Remove the ignition coil bracket.

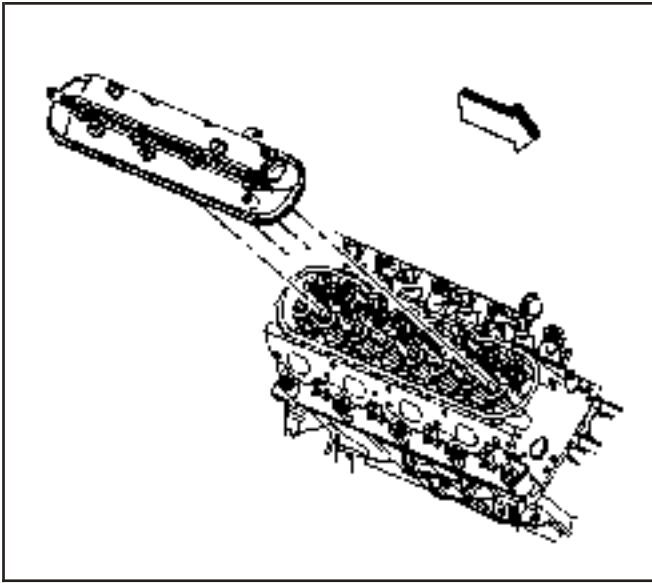


832187

10. Remove the positive crankcase ventilation (PCV) hose.

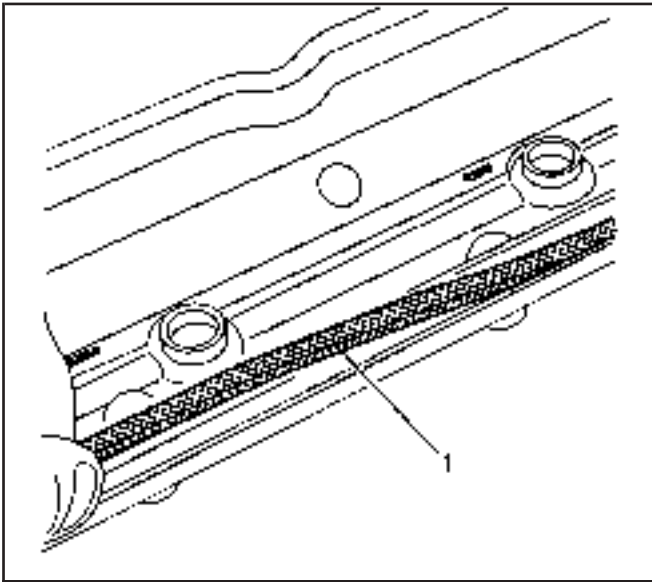


647795



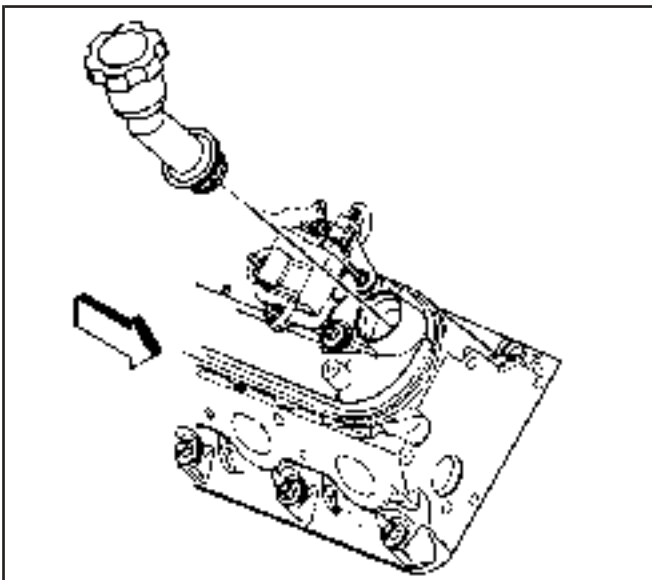
832211

11. Loosen the valve rocker arm cover bolts.
12. Remove the valve rocker arm cover.



490696

13. Remove and discard the old gasket (1).



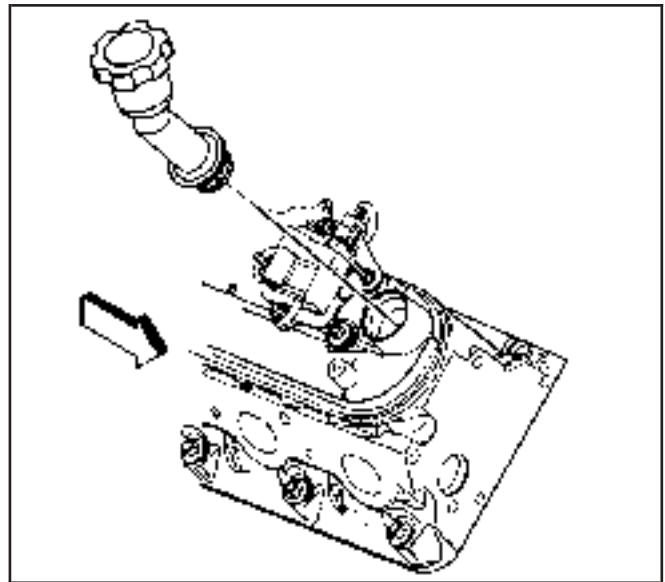
647798

14. Remove the oil fill tube from the rocker cover, if required.
15. If required, clean and inspect the rocker arm cover. Refer to *Valve Rocker Arm Cover Cleaning and Inspection*.

Installation Procedure

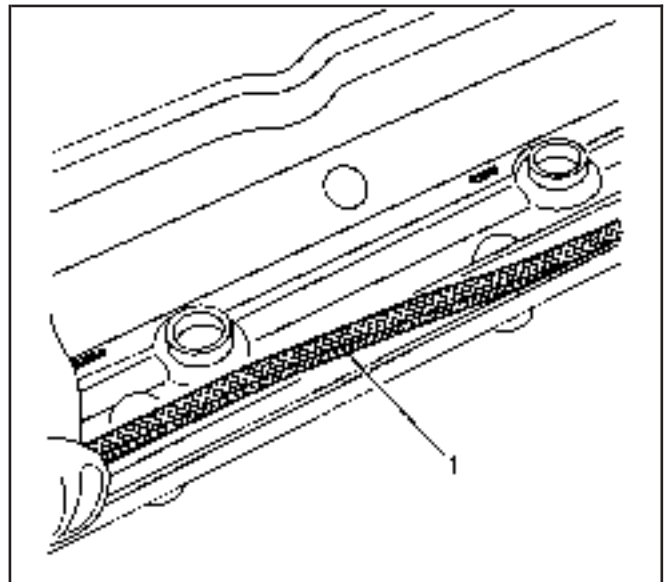
Important:

- All gasket surfaces should be free of oil or other foreign material during assembly.
 - DO NOT reuse the valve rocker arm cover gasket.
1. Lubricate the O-ring seal of the NEW oil fill tube with clean engine oil.
 2. Insert the NEW oil fill tube into the rocker arm cover.
 - Rotate the tube clockwise until locked in the proper position.
 3. Install the oil fill cap into the tube.
 - Rotate the cap clockwise until locked in the proper position.



647798

4. Install a NEW rocker cover gasket (1) into the valve rocker cover lip.



490696

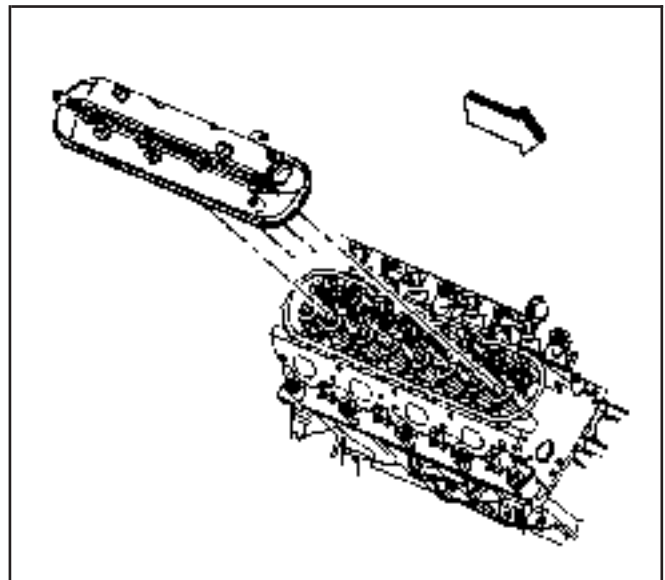
5. Install the valve rocker arm cover.

Notice: Refer to *Fastener Notice* in Cautions and Notices.

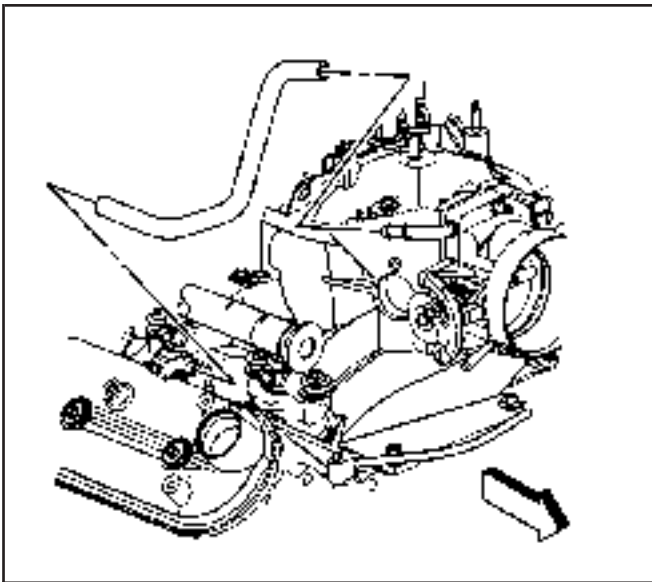
6. Tighten the rocker arm cover bolts.

Tighten

Tighten the bolts to 12 N·m (106 lb in).

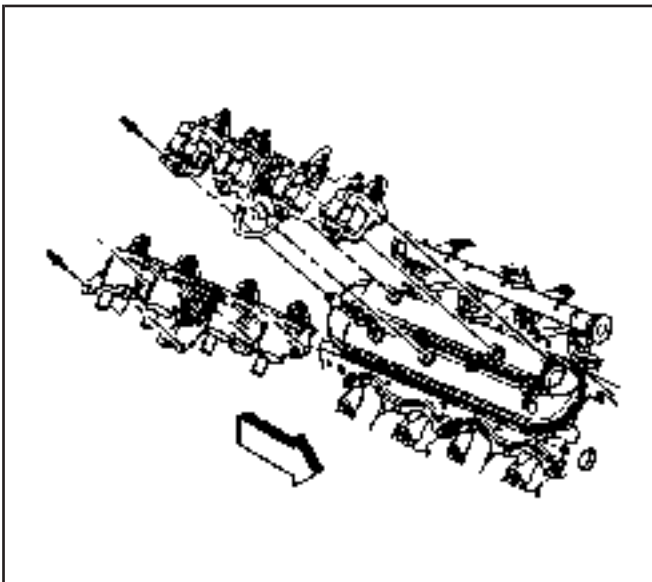


832211



647795

7. Install the PCV hose.

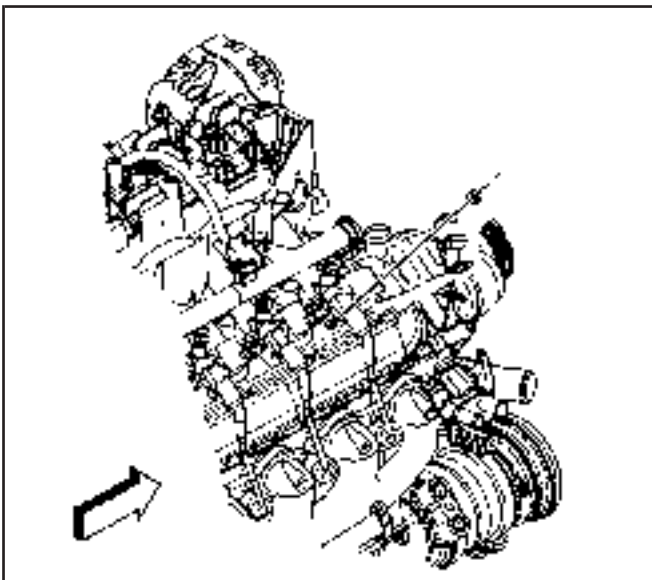


832187

8. Apply threadlock GM P/N 12345382 (Canadian P/N 10953489) or equivalent to the threads of the coil bracket studs.
9. Install the ignition coil bracket.
10. Install the ignition coil bracket studs.

Tighten

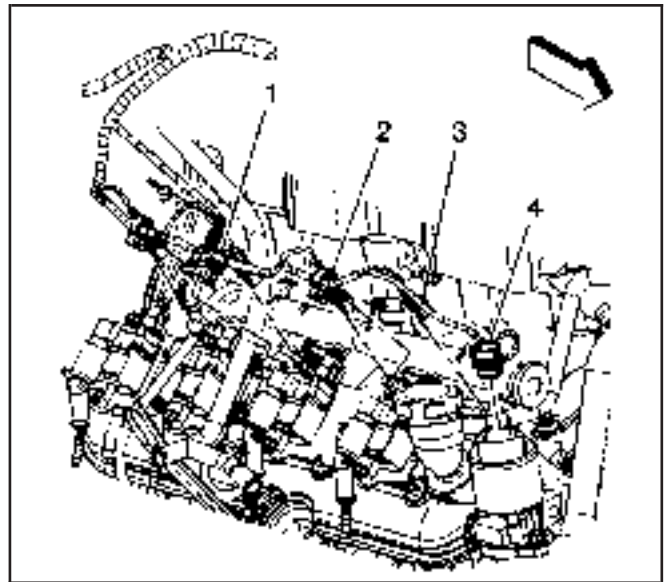
Tighten the studs to 12 N·m (106 lb in).



688018

11. If equipped with the 4.8L, 5.3L, or 6.0L (LQ4) engine, perform the following:
- 11.1. Install the heater hose bracket and nut.
- Tighten**
Tighten the nut to 9 N·m (80 lb in).
- 11.2. Position the surge tank/heater hoses to the heater hose bracket.

12. Install the spark plug wires to the ignition coils.
13. Position the engine harness, if necessary.
14. Install the harness clips (2).
15. Connect the main electrical connector (1) feeding the ignition coils.
16. Install the CPA lock.
17. Install the engine sight shield, if required. Refer to *Engine Sight Shield Replacement (4.8L, 5.3L, and 6.0L (RPO LQ4))* or *Engine Sight Shield Replacement (6.0L (RPO LQ9))*.



679598

Valve Rocker Arm and Push Rod Replacement

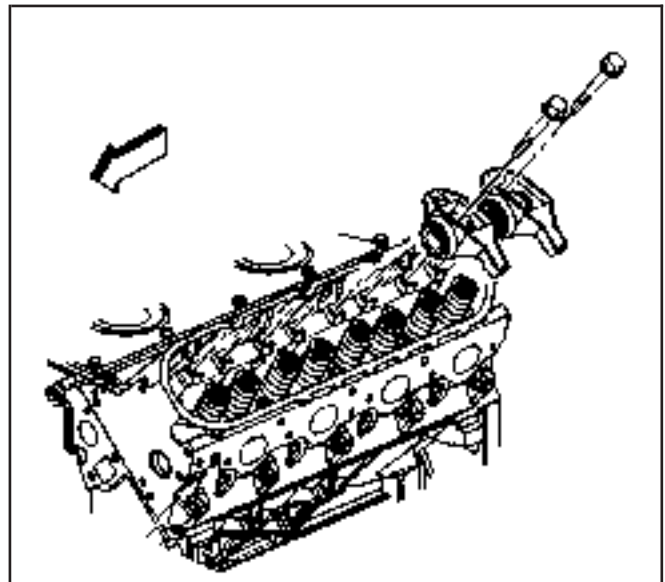
SIE-ID = 824721 LMD = 16-may-2002

Removal Procedure

1. Remove the rocker arm cover. Refer to *Valve Rocker Arm Cover Replacement - Left* or *Valve Rocker Arm Cover Replacement - Right*.

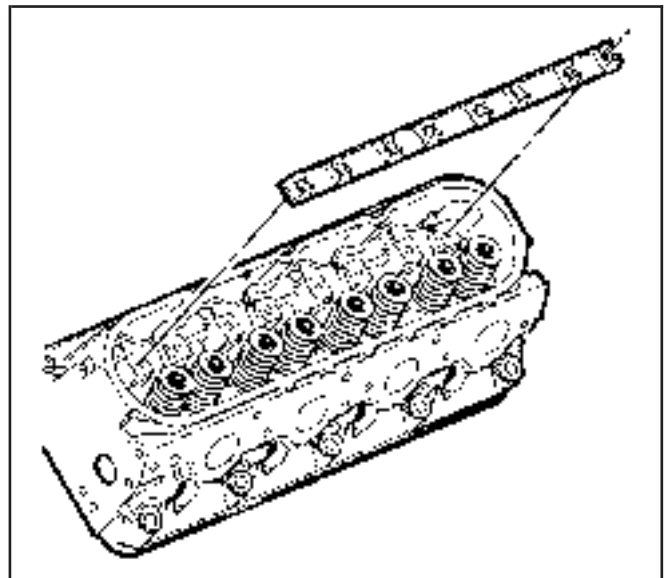
Important: Place the rocker arms, pushrods, and pivot support, in a rack so that they can be installed in the same location from which they were removed.

2. Remove the rocker arm bolts.
3. Remove the rocker arms.

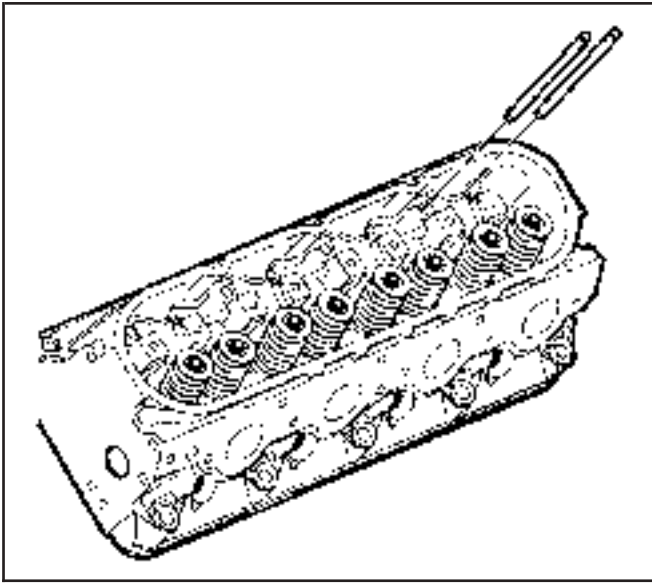


832221

4. Remove the rocker arm pivot support.

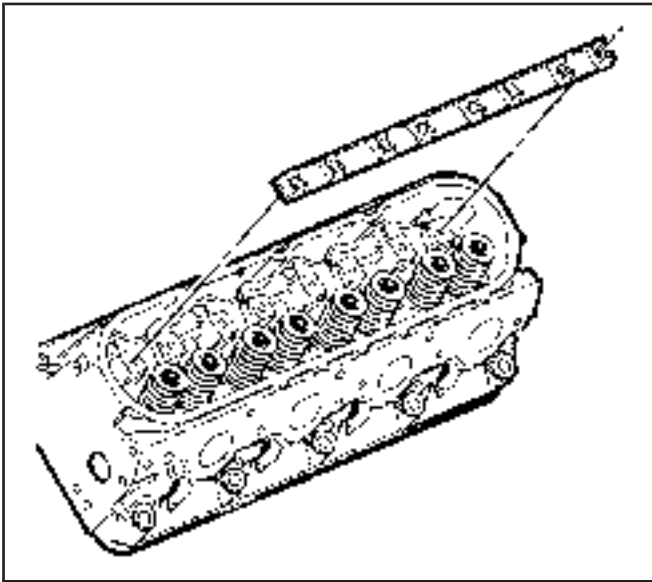


260141



260142

5. Remove the pushrods.
6. If required, clean and inspect the rocker arms and pushrods. Refer to *Valve Rocker Arm and Push Rods Cleaning and Inspection*.



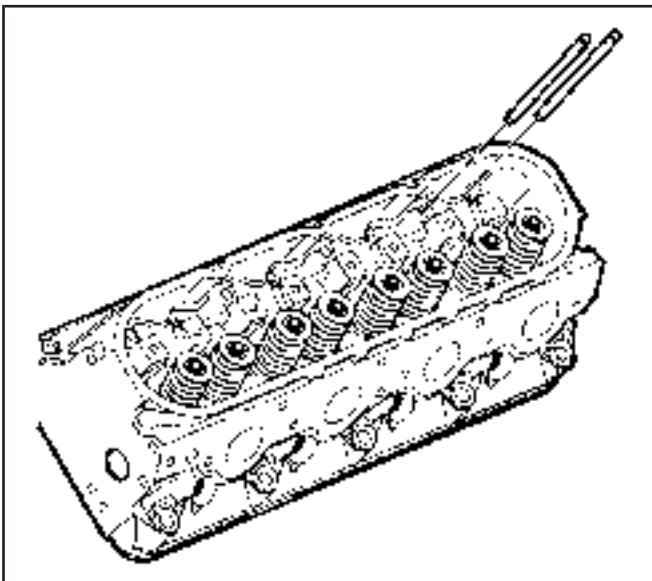
260141

Installation Procedure

Important: When reusing the valve train components, always install the components to the original location and position.

Valve lash is net build, no valve adjustment is required.

1. Lubricate the rocker arms and pushrods with clean engine oil.
2. Lubricate the flange of the rocker arm bolts with clean engine oil.
Lubricate the flange or washer surface of the bolt that will contact the rocker arm.
3. Install the rocker arm pivot support.



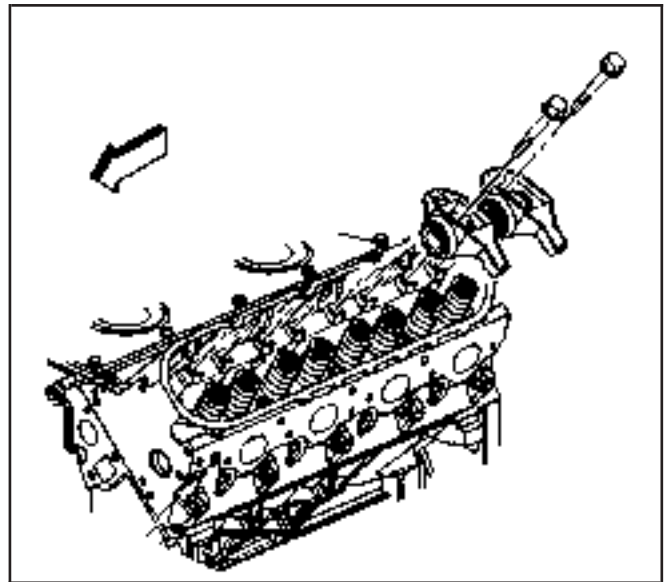
260142

Important: Make sure that the pushrods seat properly to the valve lifter sockets.

4. Install the pushrods.

Important: Make sure that the pushrods seat properly to the ends of the rocker arms. DO NOT tighten the rocker arm bolts at this time.

5. Install the rocker arms and bolts.



832221

6. Rotate the crankshaft until the number one piston is at top dead center (TDC) of the compression stroke.

In this position, cylinder number one rocker arms will be off lobe lift, and the crankshaft sprocket key will be at the 1:30 position.

The engine firing order is 1, 8, 7, 2, 6, 5, 4, 3.

Cylinders 1, 3, 5 and 7 are the left bank.

Cylinder 2, 4, 6 and 8 are the right bank.

Notice: Refer to *Fastener Notice* in Cautions and Notices.

7. With the engine in the number one firing position, tighten the following rocker arm bolts:

Tighten

- Tighten cylinders 1,2,7 and 8 exhaust valve rocker arm bolts to 30 N-m (22 lb ft).
- Tighten cylinders 1,3,4 and 5 intake valve rocker arm bolts to 30 N-m (22 lb ft).

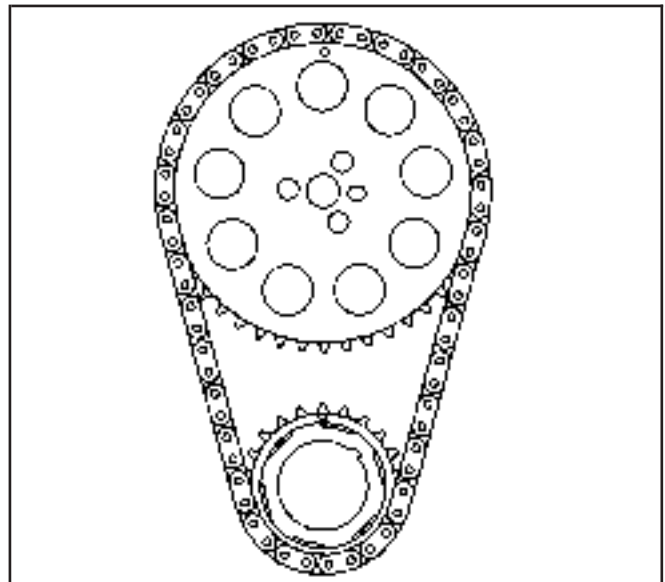
8. Rotate the crankshaft 360 degrees.

9. Tighten the following rocker arm bolts:

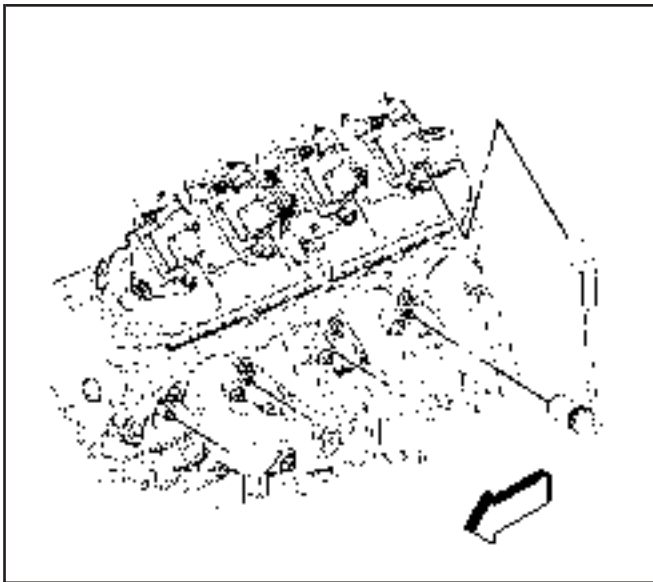
Tighten

- Tighten cylinders 3, 4, 5 and 6 exhaust valve rocker arm bolts to 30 N-m (22 lb ft).
- Tighten cylinders 2, 6, 7 and 8 intake valve rocker arm bolts to 30 N-m (22 lb ft).

10. Install the rocker arm cover. Refer to *Valve Rocker Arm Cover Replacement - Left* or *Valve Rocker Arm Cover Replacement - Right*.



661566



343699

Valve Stem Oil Seal and Valve Spring Replacement

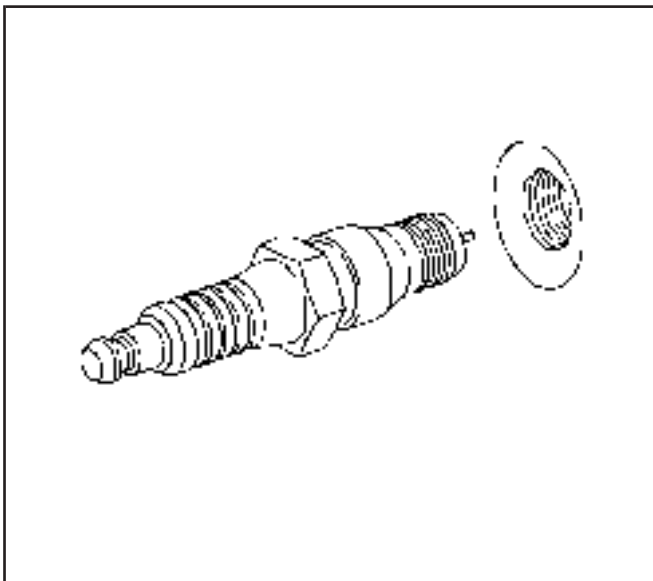
S/E-ID = 824722 LMD = 16-may-2002

Tools Required

- J 22794 Spark Plug Port Adapter
- J 38606 Valve Spring Compressor

Removal Procedure

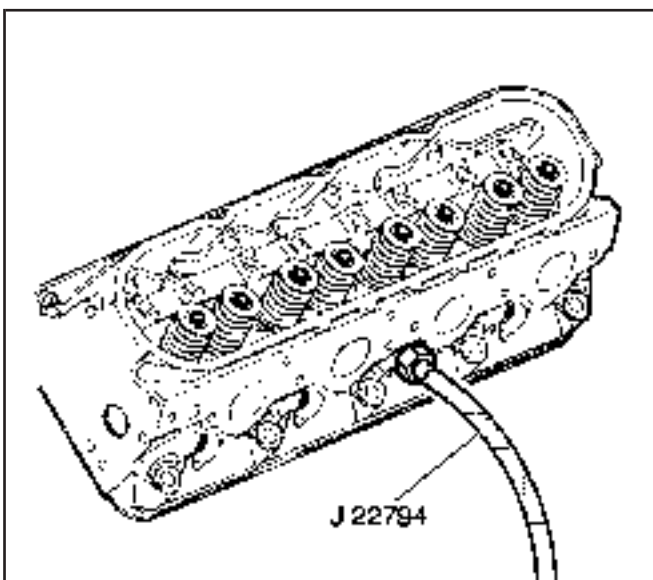
1. Remove the rocker arm. Refer to *Valve Rocker Arm and Push Rod Replacement*.
2. Disconnect the spark plug wire at the spark plug.
 - Twist each plug wire boot 1/2 turn.
 - Pull only on the boot in order to remove the wire from the spark plug.



14824

Important: Remove the spark plugs from the cylinder head with the engine at room temperature.

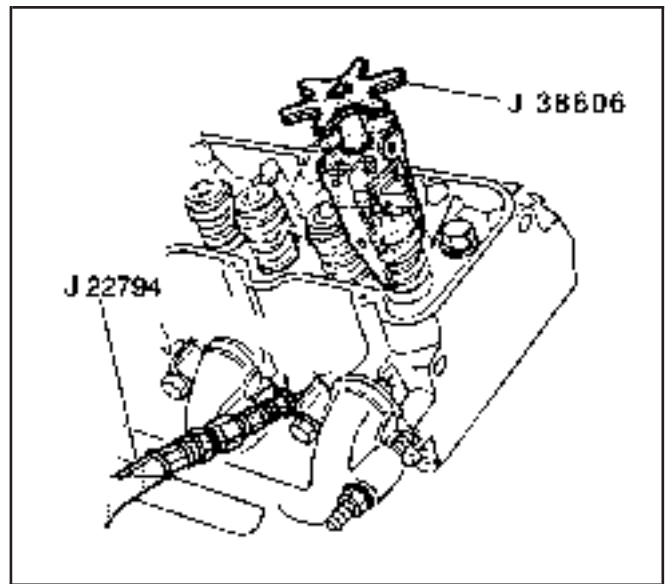
3. Loosen the spark plug 1 or 2 turns.
4. Brush or air blast away any dirt or debris from around the spark plug.
5. Remove the spark plug.



310140

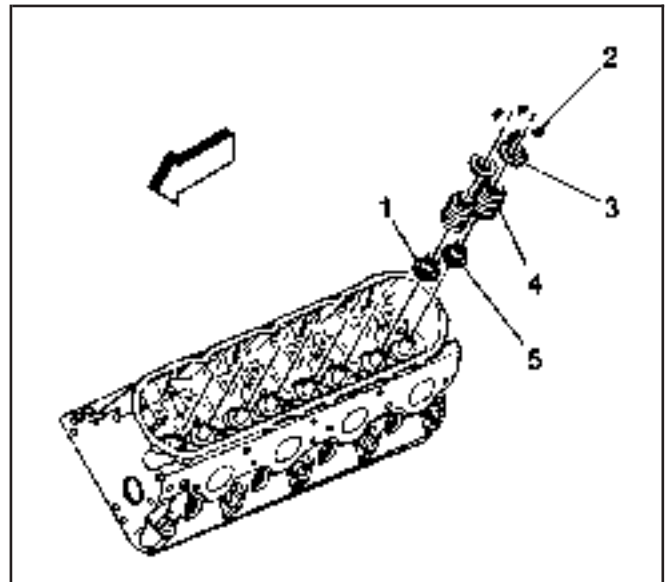
6. Install the J 22794 into the spark plug hole.
7. Attach an air hose to the J 22794.
8. Apply compressed air to the J 22794 in order to hold the valves in place.

9. Use the *J 38606* in order to compress the valve spring.



218211

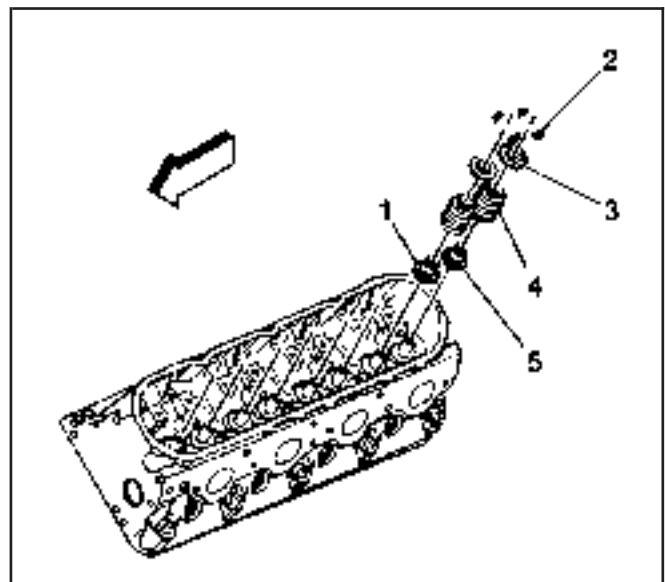
10. Remove the valve stem keys (2).
11. Carefully release the valve spring tension.
12. Remove the *J 38606*.
13. Remove the valve spring cap (3).
14. Remove the valve spring (4).
15. Remove the valve stem oil seal and shim (1, 5)



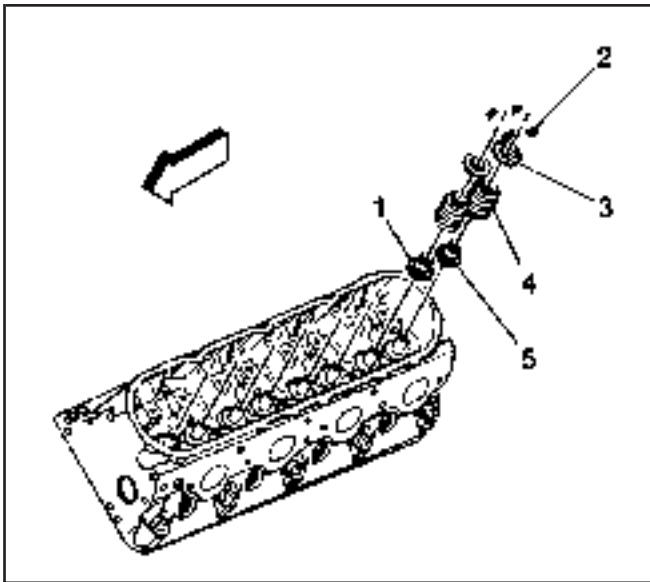
832259

Installation Procedure

1. Clean the cylinder head valve spring seat and/or shim area.
2. Lubricate the valve guide and valve stem oil seal with clean engine oil.
3. Install the valve stem oil seal and shim (1, 5).

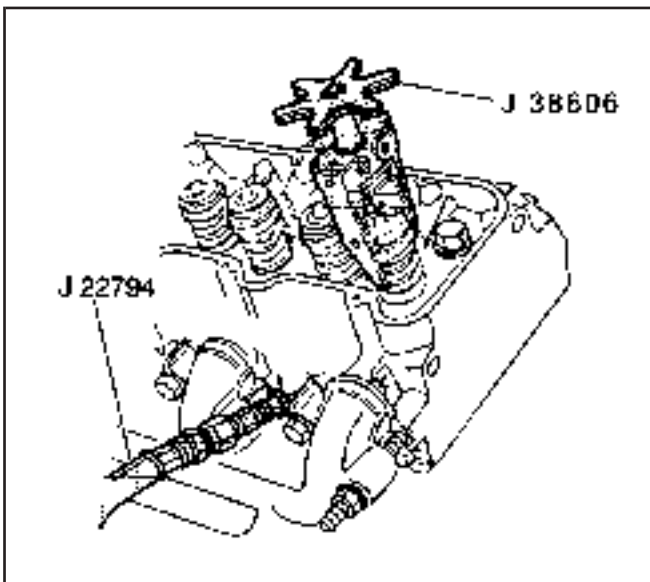


832259



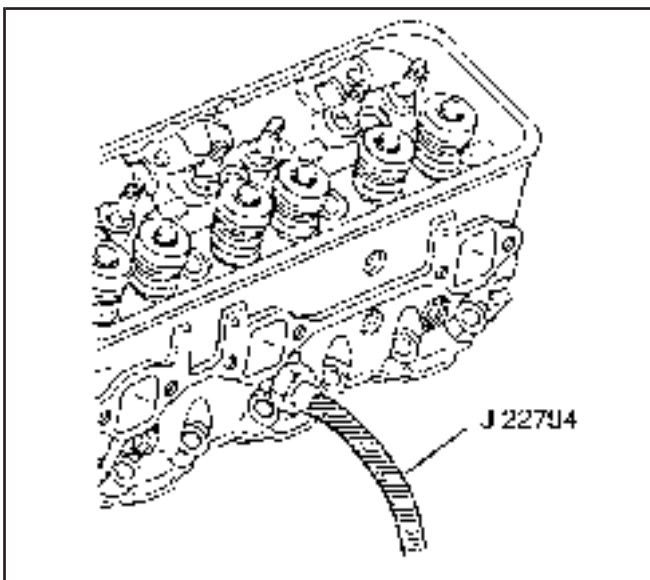
832259

4. Install the valve spring (4).
5. Install the valve spring cap (3).



218211

6. Compress the valve spring using the *J 38606*.
7. Install the valve keys.
 - Use grease in order to hold the valve keys in place.
 - Make sure the keys seat properly in the groove of the valve stem.
 - Carefully release the valve spring pressure, making sure the valve keys stay in place.
 - Remove the *J 38606*.
 - Tap the end of the valve stem with a plastic faced hammer to seat the keys, if necessary.



65039

8. Remove the *J 22794* from the spark plug port.

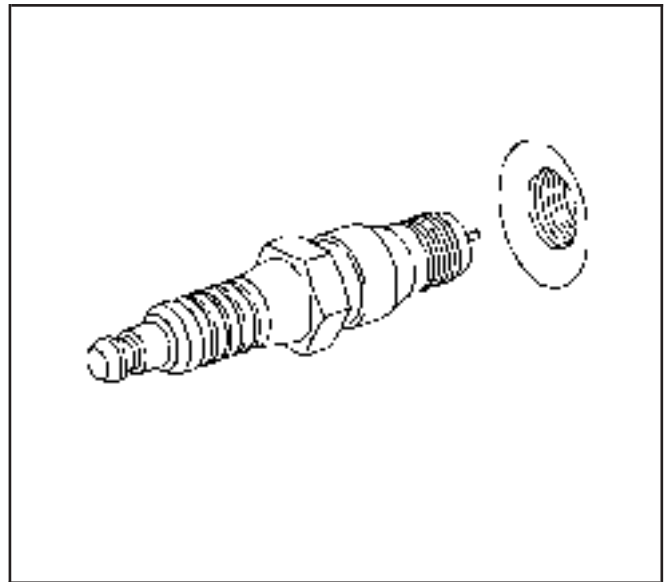
Notice: Refer to *Fastener Notice* in Cautions and Notices.

9. Hand start the spark plug.

Tighten

Tighten the spark plug to 15 N·m (11 lb ft).

10. Install the spark plug wires at the ignition coil.
11. Install the spark plug wire to the spark plug.
12. Inspect the wires for proper installation:
 - Push sideways on each boot in order to check for proper installation.
 - Reinstall any loose boot.
13. Install the rocker arm. Refer to *Valve Rocker Arm and Push Rod Replacement*.



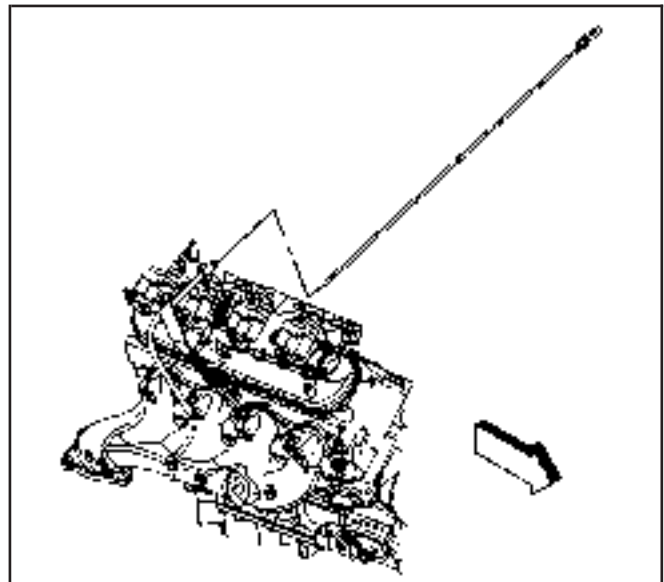
14824

Oil Level Indicator and Tube Replacement

SIE-ID = 824727 LMD = 19-mar-2002

Removal Procedure

1. Remove the oil level indicator.

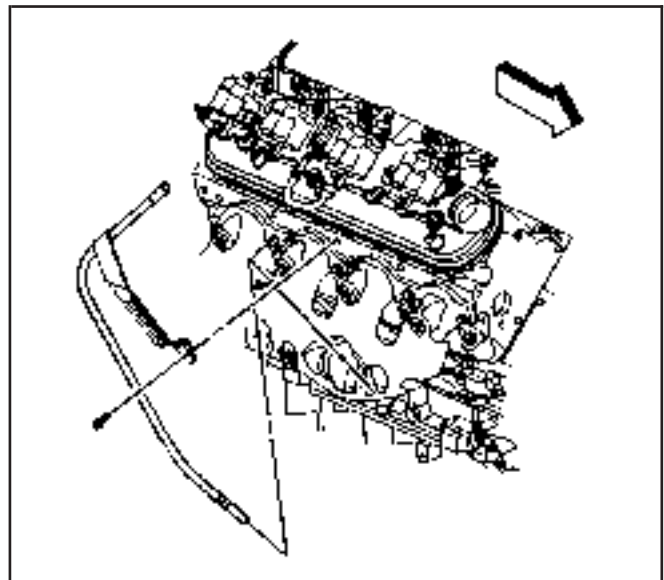


647796

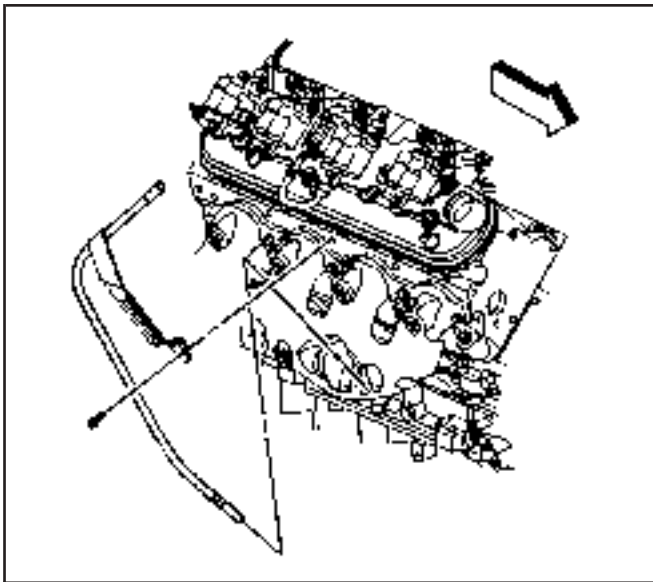
2. Remove the oil level indicator tube bolt.
3. Remove the oil level indicator tube.

Important: The O-ring seal may be reused if not cut or damaged.

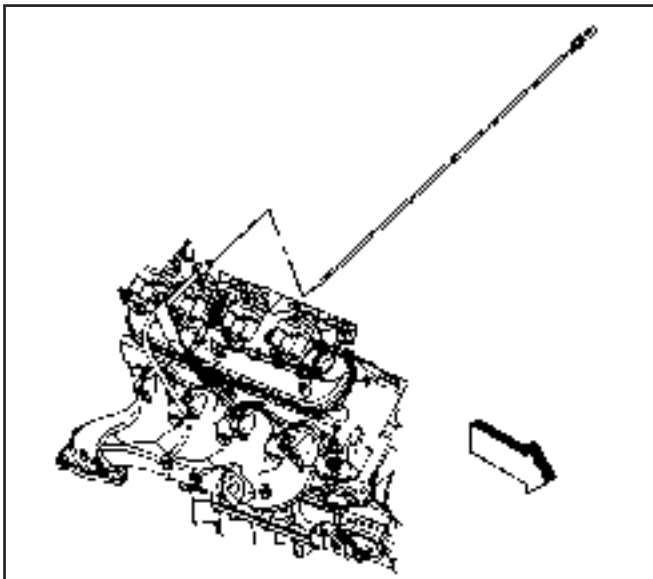
4. Inspect the O-ring seal for cuts or damage.
5. Remove the O-ring seal from the tube, if required.



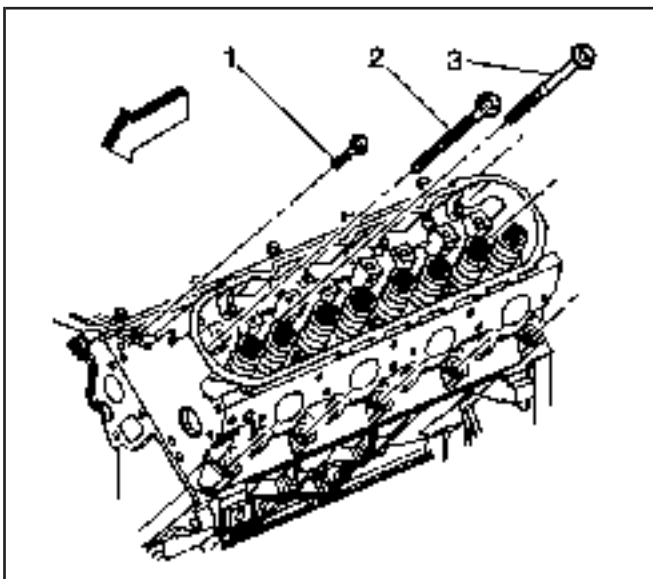
832260



832260



647796



832957

Installation Procedure

1. Lubricate the O-ring seal with clean engine oil.
2. Install a NEW O-ring seal onto the oil level indicator tube, if required.
3. Install the oil level indicator tube between the exhaust manifold and engine block.
4. Raise and suitably support the vehicle. Refer to *Lifting and Jacking the Vehicle* in General Information.
5. Install the oil level indicator tube into the block. The tube must be installed with the collar flush to the block.
6. Lower the vehicle.

Notice: Refer to *Fastener Notice* in Cautions and Notices.

7. Install the oil level indicator tube bolt

Tighten

Tighten the bolt to 25 N·m (18 lb ft).

8. Install the oil level indicator.

Cylinder Head Replacement - Left

SIE-ID = 824728 LMD = 16-may-2002

Tools Required

- J 36660-A Torque Angle Meter
- J 42385-200 Thread Repair Kit

Removal Procedure

1. Remove the generator bracket. Refer to *Generator Replacement (4.8L, 5.3L, and 6.0L Engines)* or *Generator Replacement (8.1L Engine)* in Engine Electrical.
2. Remove the coolant air bleed pipe. Refer to *Coolant Air Bleed Pipe Assembly Replacement (4.8L, 5.3L, and 6.0L Engines)* in Engine Cooling.

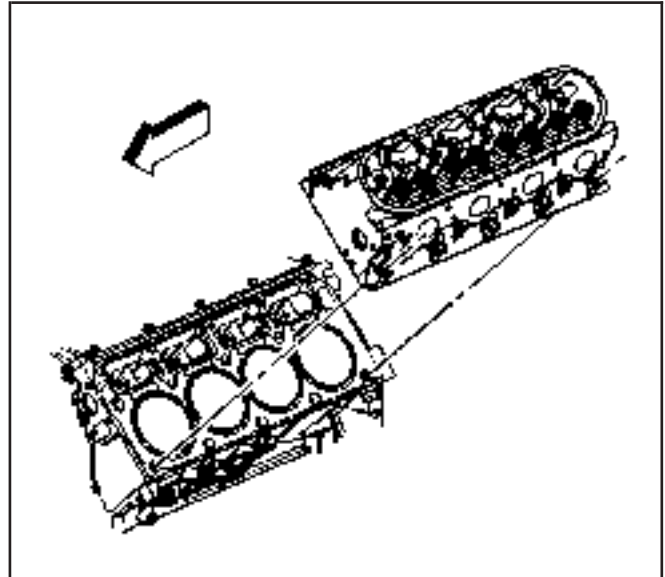
3. Remove the left exhaust manifold. Refer to *Exhaust Manifold Replacement - Left (4.8L, 5.3L, and 6.0L Engines)* or *Exhaust Manifold Replacement - Left (8.1L Engine)* in Engine Exhaust.
4. Remove the pushrods. Refer to *Valve Rocker Arm and Push Rod Replacement*.

Important: The cylinder head bolts are NOT reusable.

5. Remove and discard the cylinder head bolts (1, 2, 3).

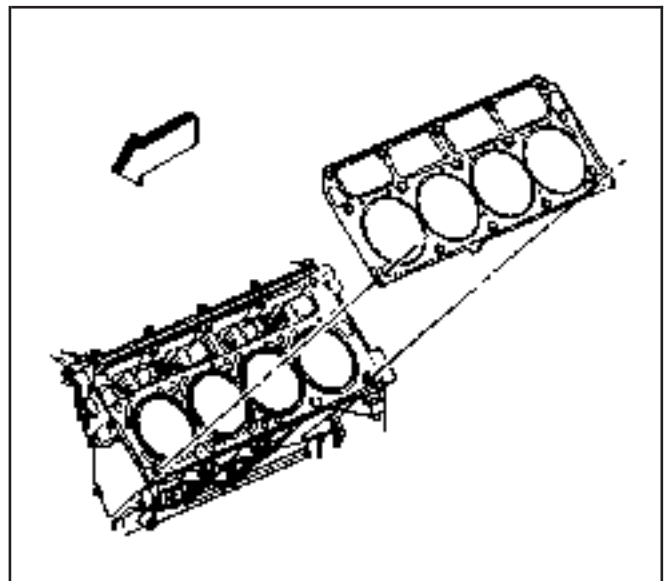
Notice: SIO-ID = 13838 LMD = 11-oct-1995 After removal, place the cylinder head on two wood blocks to prevent damage.

6. Remove the cylinder head.

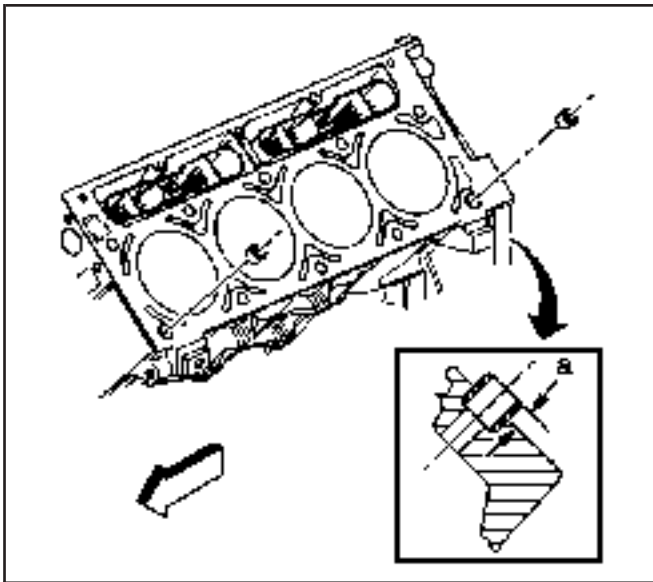


832958

7. Remove and discard the cylinder head gasket.
8. If required, clean and inspect the cylinder head. Refer to *Cylinder Head Cleaning and Inspection*.



832962



832969

Installation Procedure

Caution: SIO-ID = 5011 LMD = 04-dec-1994 **Wear safety glasses in order to avoid eye damage.**

Notice: SIO-ID = 96999 LMD = 13-aug-1996 Clean all dirt, debris, and coolant from the engine block cylinder head bolt holes. Failure to remove all foreign material may result in damaged threads, improperly tightened fasteners or damage to components.

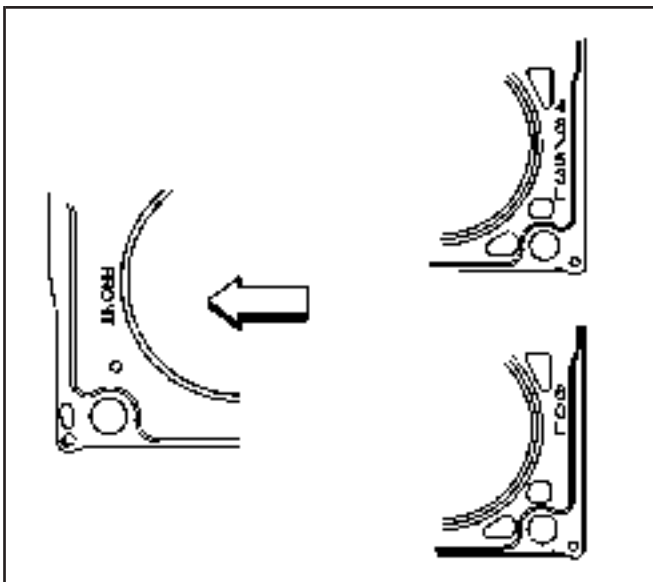
Important:

- Do not reuse the cylinder head bolts. Install NEW cylinder head bolts during assembly.
- Do not use any type of sealant on the cylinder head gasket, unless specified.
- The cylinder head gaskets must be installed in the proper direction and position.

1. Clean the engine block cylinder head bolt holes (if required).

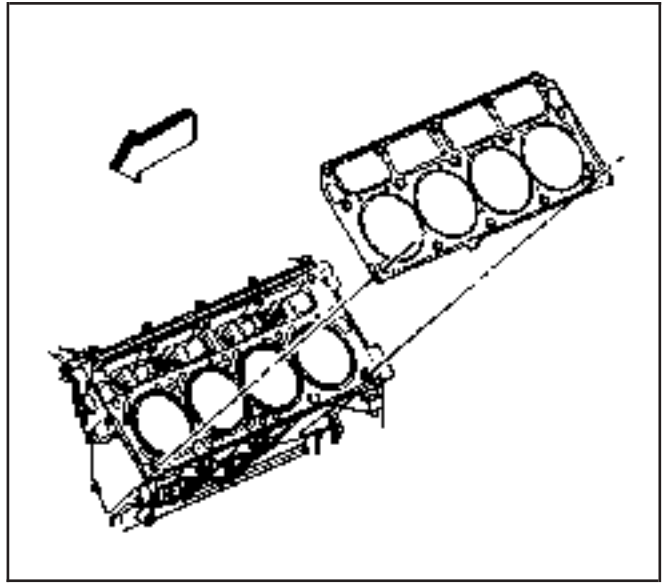
Thread repair tool J 42385-107, found in J 42385-200 may be used to clean the threads of old threadlocking material.

2. Use spray cleaner GM P/N 12346139, P/N 12377981, (Canadian P/N 10953463) or equivalent into the hole.
3. Clean the cylinder head bolt holes with compressed air.
4. Check the cylinder head locating pins for proper installation, location (a) 8.3 mm (0.327 in).
5. When properly installed, with FRONT on the left side, the tab on the cylinder head gasket should be located left of center or closer to the front of the engine.



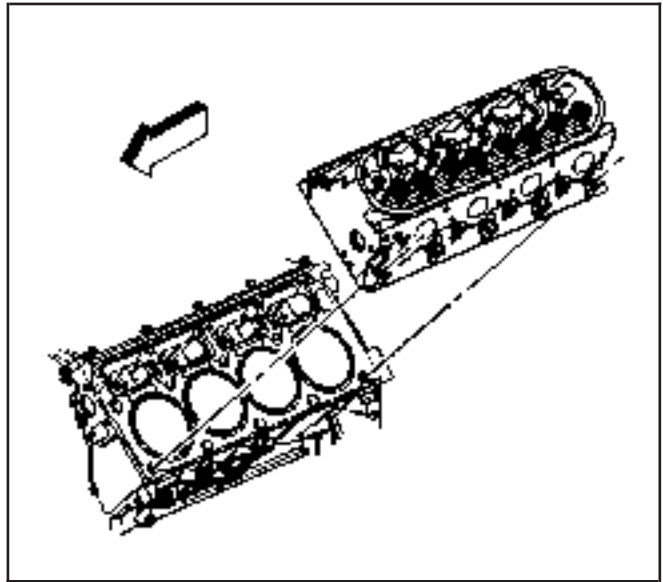
832963

6. Install the NEW cylinder head gasket.



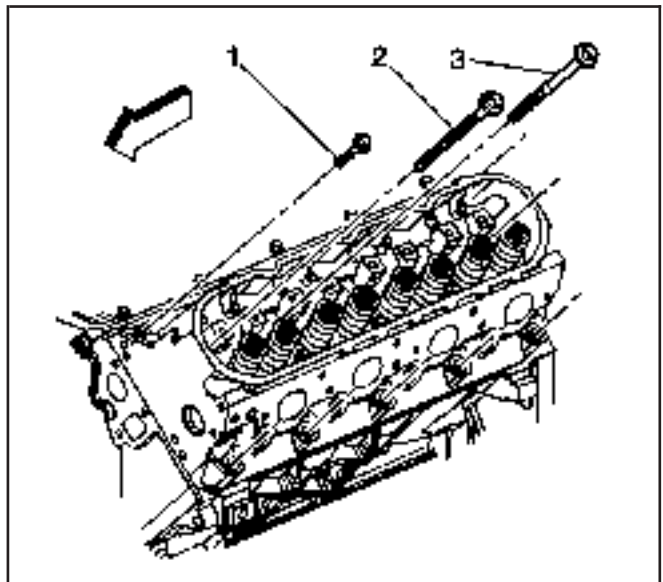
832962

7. Install the cylinder head.

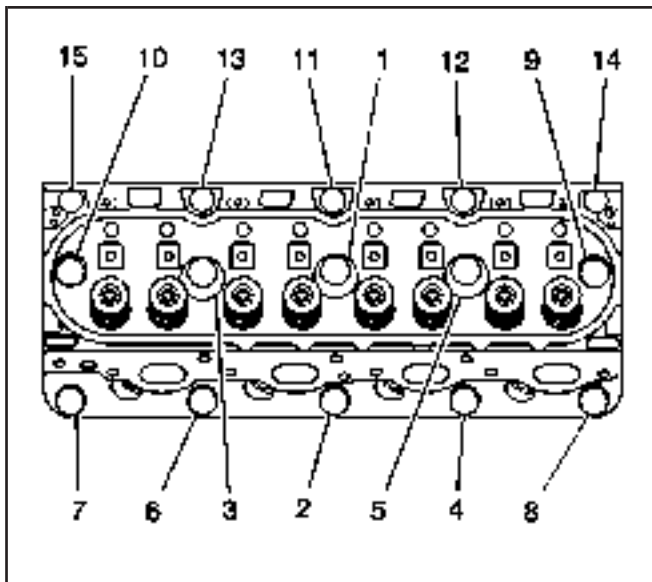


832958

8. Install NEW cylinder head bolts (1, 2, 3).



832957



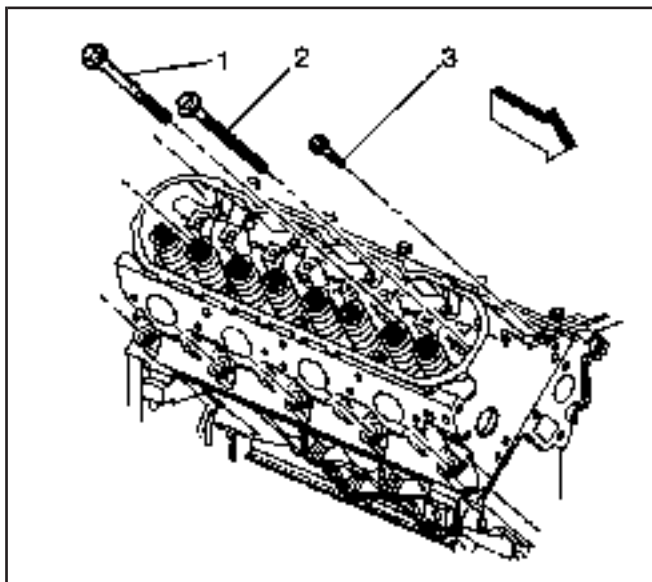
832971

Notice: Refer to *Fastener Notice* in Cautions and Notices.

9. Tighten the cylinder head bolts.

Tighten

- 9.1. Tighten the M11 bolts a first pass in sequence to 30 N·m (22 lb ft).
 - 9.2. Tighten the M11 bolts a second pass in sequence to 90 degrees using *J 36660-A*.
 - 9.3. Tighten the M11 bolts (1, 2, 3, 4, 5, 6, 7, 8) to 90 degrees and the M11 bolts (9 and 10) to 50 degrees a final pass in sequence using *J 36660-A*.
 - 9.4. Tighten the M8 bolts (11, 12, 13, 14, 15) to 30 N·m (22 lb ft). Begin with the center bolt (11) and alternating side-to-side, work outward tightening all of the bolts.
10. Install the pushrods. Refer to *Valve Rocker Arm and Push Rod Replacement*.
 11. Install the left exhaust manifold. Refer to *Exhaust Manifold Replacement - Left (4.8L, 5.3L, and 6.0L Engines)* or *Exhaust Manifold Replacement - Left (8.1L Engine)* in Engine Exhaust.
 12. Install the coolant air bleed pipe. Refer to *Coolant Air Bleed Pipe Assembly Replacement (4.8L, 5.3L, and 6.0L Engines)* in Engine Cooling.
 13. Install the generator bracket. Refer to *Generator Replacement (4.8L, 5.3L, and 6.0L Engines)* or *Generator Replacement (8.1L Engine)* in Engine Electrical.



832959

Cylinder Head Replacement - Right

SIE-ID = 824732 LMD = 16-may-2002

Tools Required

- *J 36660-A* Torque Angle Meter
- *J 42385-200* Thread Repair Kit

Removal Procedure

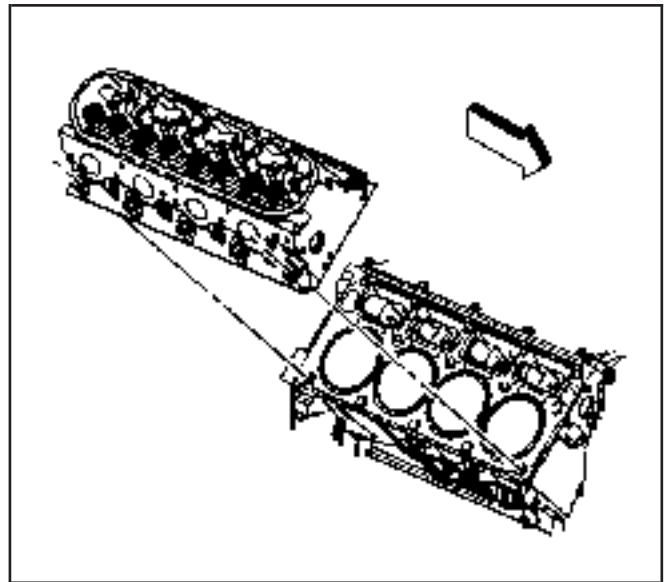
1. Remove the oil level indicator. Refer to *Oil Level Indicator and Tube Replacement*.
2. Remove the coolant air bleed pipe. Refer to *Coolant Air Bleed Pipe Assembly Replacement (4.8L, 5.3L, and 6.0L Engines)* in Engine Cooling.
3. Remove the right exhaust manifold. Refer to *Exhaust Manifold Replacement - Right (4.8L, 5.3L, and 6.0L Engines)* or *Exhaust Manifold Replacement - Right (8.1L Engine)* in Engine Exhaust.
4. Remove the pushrods. Refer to *Valve Rocker Arm and Push Rod Replacement*.

Important: The cylinder head bolts are NOT reusable.

5. Remove and discard the cylinder head bolts (1, 2, 3).

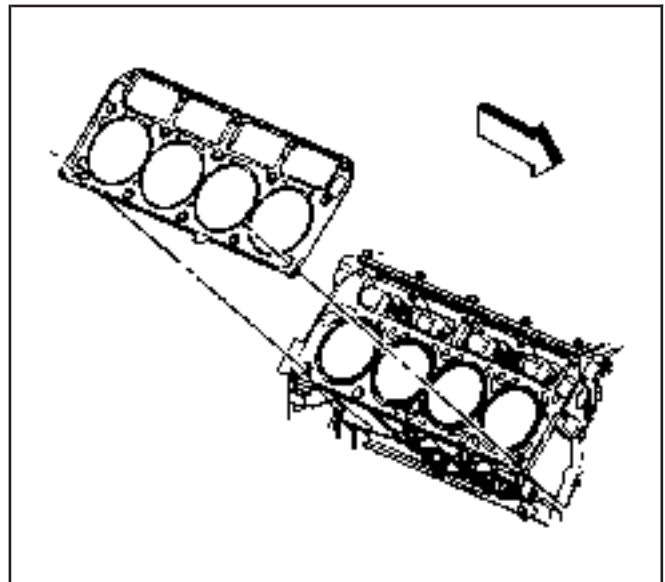
Notice: SIO-ID = 13838 LMD = 11-oct-1995 After removal, place the cylinder head on two wood blocks to prevent damage.

6. Remove the cylinder head.



832960

- 7. Remove and discard the cylinder head gasket.
- 8. If required, clean and inspect the cylinder head. Refer to *Cylinder Head Cleaning and Inspection*.



832965

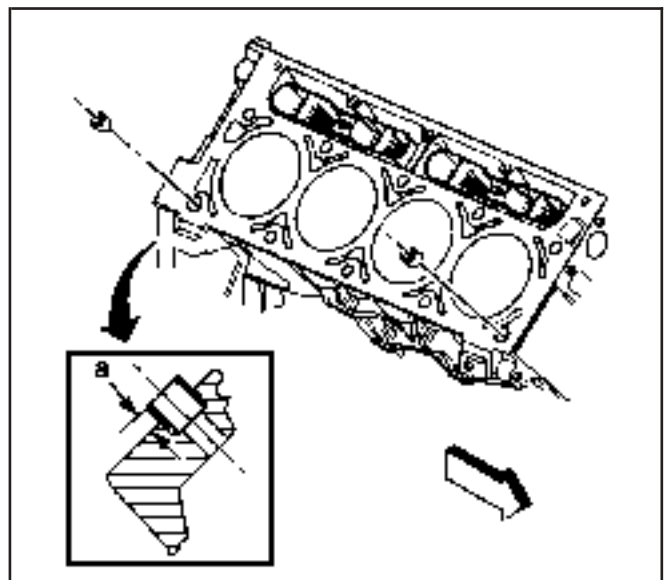
Installation Procedure

Caution: SIO-ID = 5011 LMD = 04-dec-1994 **Wear safety glasses in order to avoid eye damage.**

Notice: SIO-ID = 96999 LMD = 13-aug-1996 Clean all dirt, debris, and coolant from the engine block cylinder head bolt holes. Failure to remove all foreign material may result in damaged threads, improperly tightened fasteners or damage to components.

Important:

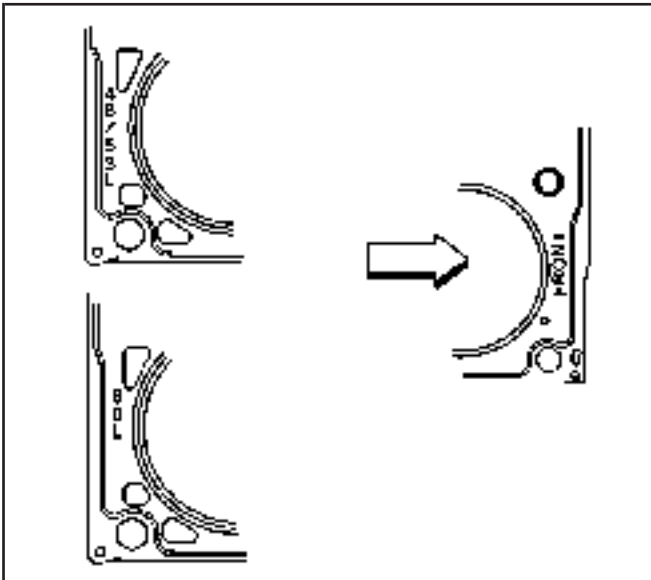
- Do not reuse the cylinder head bolts. Install NEW cylinder head bolts during assembly.
 - Do not use any type of sealant on the cylinder head gasket, unless specified.
 - The cylinder head gaskets must be installed in the proper direction and position.
1. Clean the engine block cylinder head bolt holes, if required.



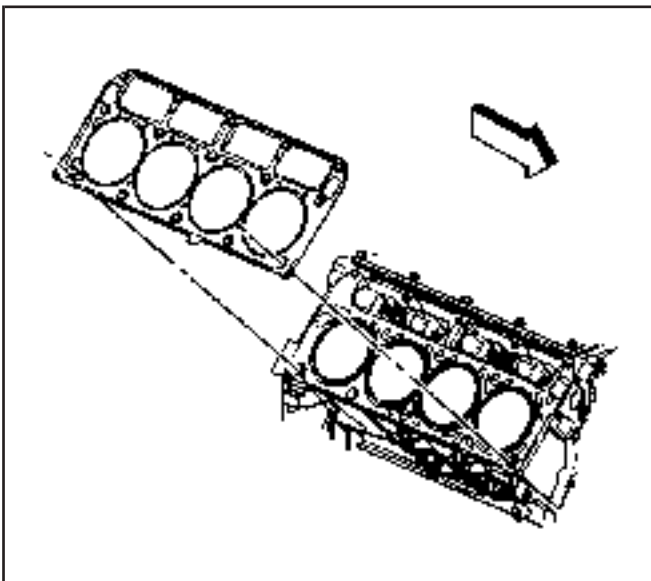
832970

Thread repair tool J 42385-107, found in J 42385-200 may be used to clean the threads of old threadlocking material.

2. Use spray cleaner GM P/N 12346139, P/N 12377981, (Canadian P/N 10953463) or equivalent into the hole.
3. Clean the cylinder head bolt holes with compressed air.
4. Check the cylinder head locating pins for proper installation, location (a) 8.3 mm (0.327 in).
5. When properly installed, with FRONT on the right side, the tab on the cylinder head gasket should be located right of center or closer to the front of the engine.



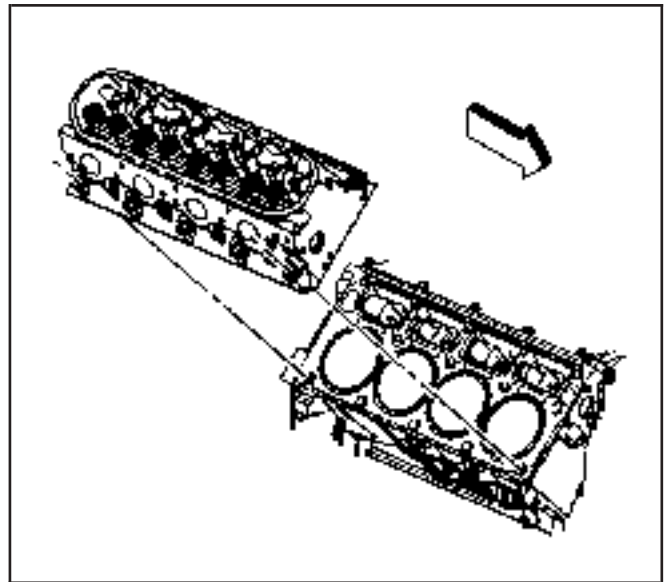
832967



832965

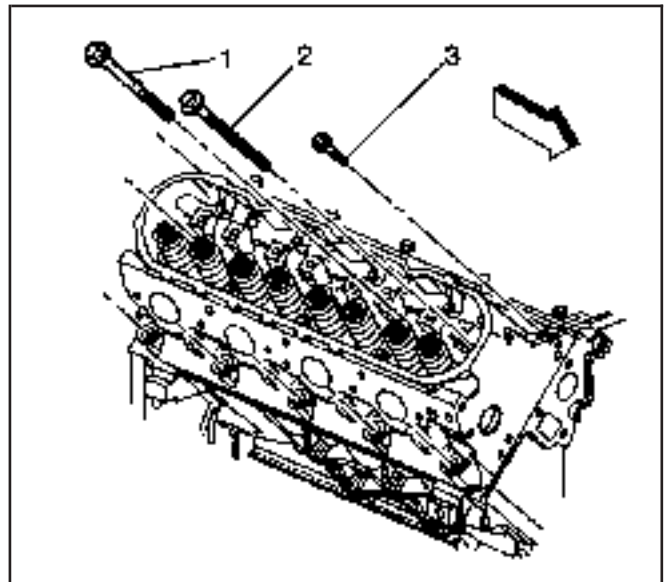
6. Install the NEW cylinder head gasket.

7. Install the cylinder head.



832960

8. Install the NEW cylinder head bolts.



832959

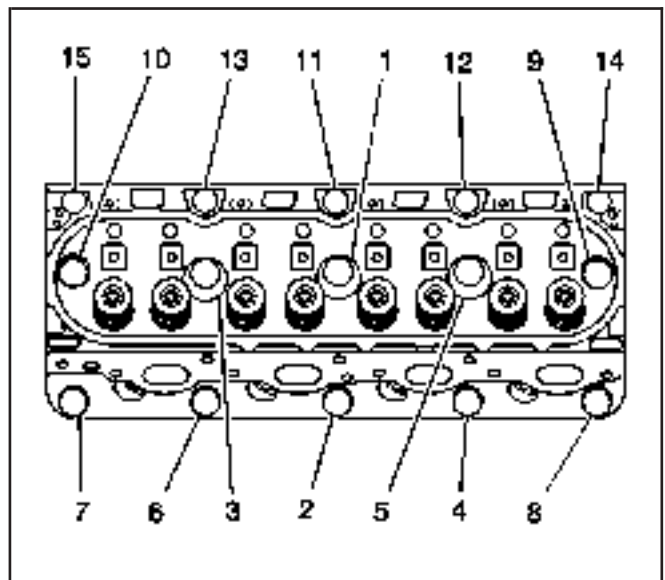
Notice: Refer to *Fastener Notice* in Cautions and Notices.

9. Tighten the cylinder head bolts.

Tighten

- 9.1. Tighten the M11 bolts a first pass in sequence to 30 N·m (22 lb ft).
- 9.2. Tighten the M11 bolts a second pass in sequence to 90 degrees using *J 36660-A*.
- 9.3. Tighten the M11 bolts (1, 2, 3, 4, 5, 6, 7, 8) to 90 degrees and the M11 bolts (9 and 10) to 50 degrees a final pass in sequence using *J 36660-A*.
- 9.4. Tighten the M8 bolts (11, 12, 13, 14, 15) to 30 N·m (22 lb ft). Begin with the center bolt (11) and alternating side-to-side, work outward tightening all of the bolts.

10. Install the pushrods. Refer to *Valve Rocker Arm and Push Rod Replacement*.



832971

11. Install the right exhaust manifold. Refer to *Exhaust Manifold Replacement - Right (4.8L, 5.3L, and 6.0L Engines)* or *Exhaust Manifold Replacement - Right (8.1L Engine)* in Engine Exhaust.
12. Install the coolant air bleed pipe. Refer to *Coolant Air Bleed Pipe Assembly Replacement (4.8L, 5.3L, and 6.0L Engines)* in Engine Cooling.
13. Install the oil level indicator. Refer to *Oil Level Indicator and Tube Replacement*.

Valve Lifter Replacement

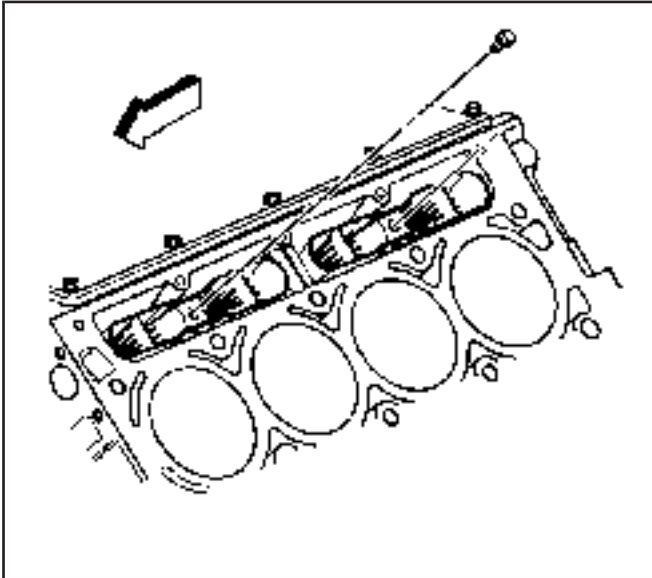
SIE-ID = 824733 LMD = 28-may-2002

Tools Required

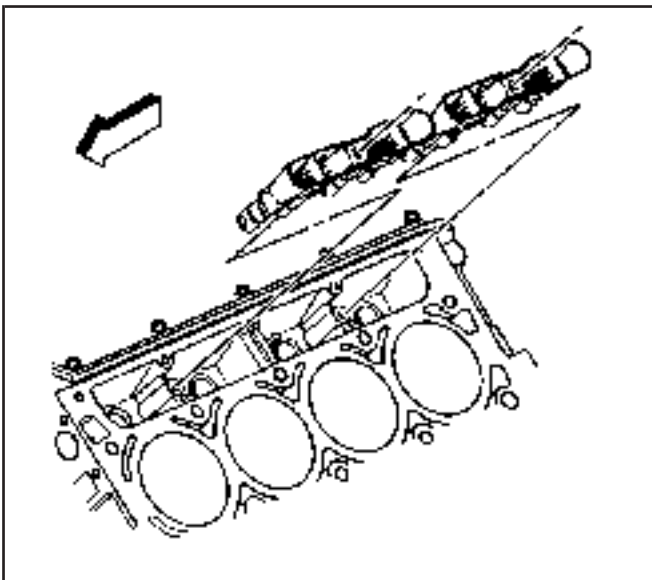
J 3049-A Valve Lifter Remover

Removal Procedure

1. Remove the cylinder head and gasket. Refer to *Cylinder Head Replacement - Left* or *Cylinder Head Replacement - Right*.
2. Remove the valve lifter guide bolts.
3. Remove the valve lifters and guide.



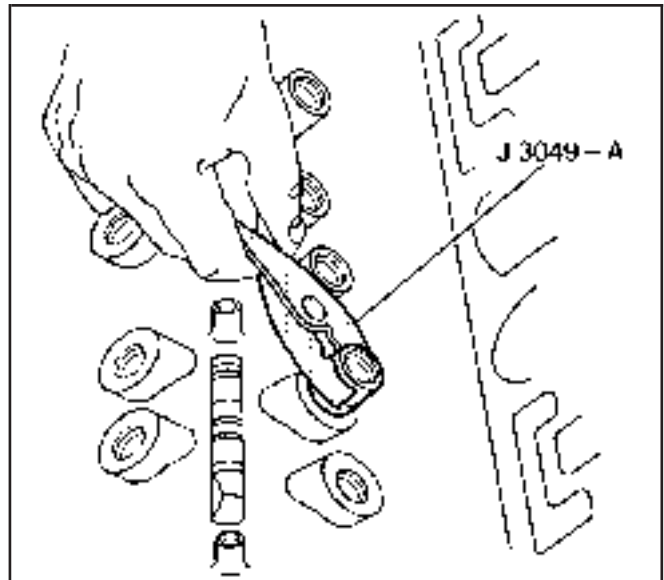
832972



832973

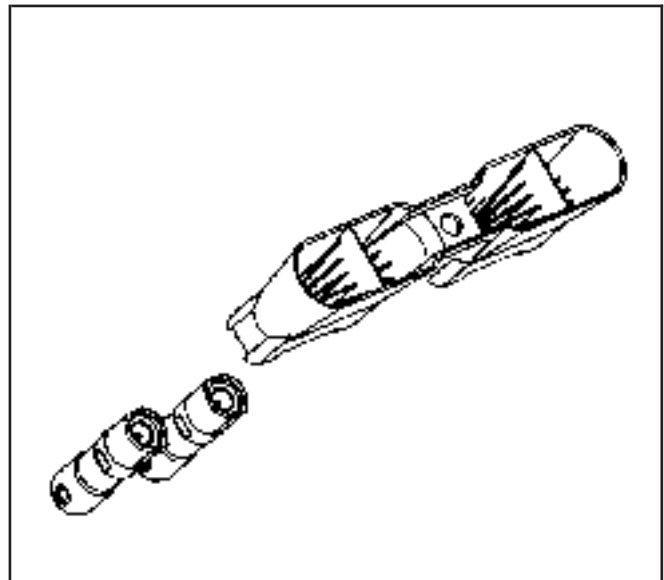
Important: Some valve lifters may be stuck in their bores because of gum or varnish deposits.

4. Use *J 3049-A* or equivalent in order to remove the valve lifters, if required.



31350

5. Remove the valve lifters from the guide.
6. Organize or mark the components so that they can be installed in the same location from which they were removed.
7. If required, clean and inspect the valve lifters. Refer to *Valve Lifters and Guides Cleaning and Inspection*.

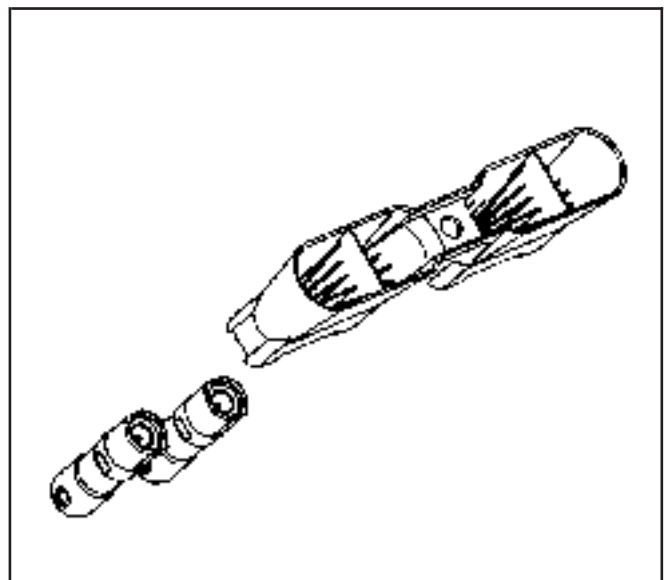


63233

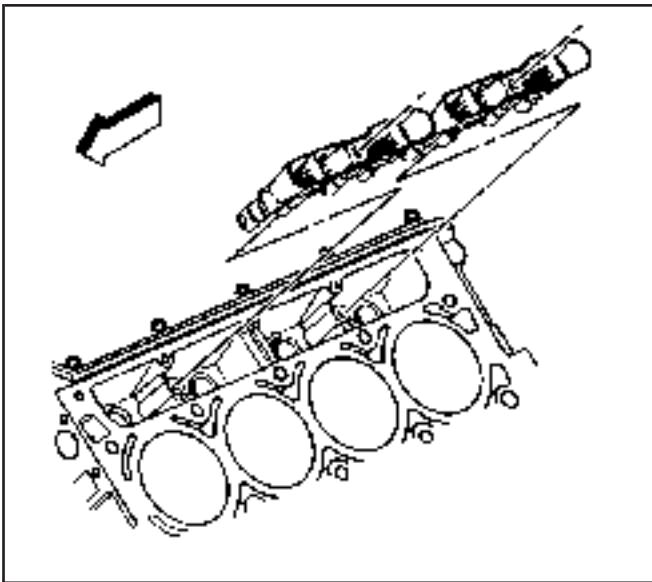
Installation Procedure

Important: When reusing valve lifters, install the lifters to their original locations.

1. Lubricate the valve lifters and engine block valve lifter bores with clean engine oil.
2. Insert the valve lifters into the lifter guides.
Align the flat area on the top of the lifter with the flat area in the lifter guide bore. Push the lifter completely into the guide bore.

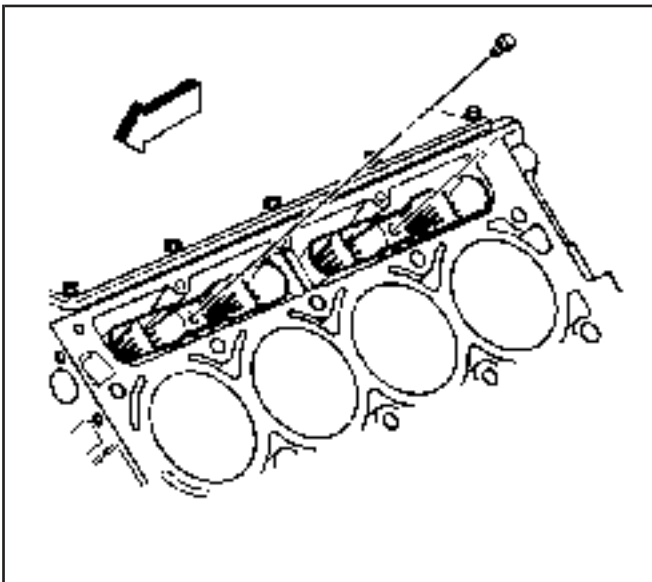


63233



832973

3. Install the valve lifters and guide to the engine block.



832972

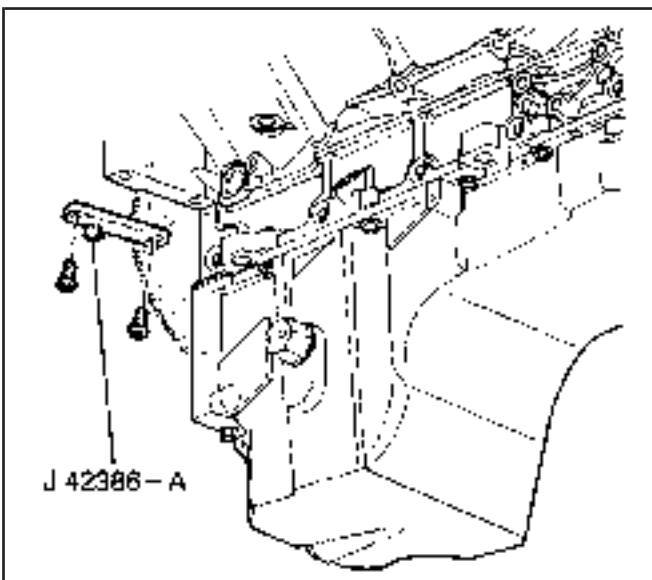
Notice: Refer to *Fastener Notice* in Cautions and Notices.

4. Install the valve lifter guide bolts.

Tighten

Tighten the bolt to 12 N·m (106 lb in).

5. Install the cylinder head and gasket. Refer to *Cylinder Head Replacement - Left* or *Cylinder Head Replacement - Right*.



260126

Crankshaft Balancer Replacement

SIE-ID = 824734 LMD = 28-jan-2002

Tools Required

- J 41816 Crankshaft Balancer Remover
- J 41816-2 Crankshaft End Protector
- J 42386-A Flywheel Holding Tool
- J 41665 Crankshaft Balancer and Sprocket Installer
- J 36660-A Torque Angle Meter

Removal Procedure

1. Remove the air conditioning (A/C) drive belt, if equipped. Refer to *Drive Belt Replacement - Air Conditioning*.
2. Remove the accessory drive belt, if not equipped with A/C. Refer to *Drive Belt Tensioner Replacement - Air Conditioning*.

3. Remove the fan shroud - lower. Refer to *Fan Shroud Replacement - Lower* in Engine Cooling.
4. Remove the starter motor. Refer to *Starter Motor Replacement (4.8L, 5.3L, and 6.0L Engines)* or *Starter Motor Replacement (8.1L Engine)* in Engine Electrical.

Important:

- Make sure that the teeth of the *J 42386-A* mesh with the teeth of the engine flywheel.
- The crankshaft balancer is balanced as an individual component. It is not necessary to mark the balancer prior to removal.

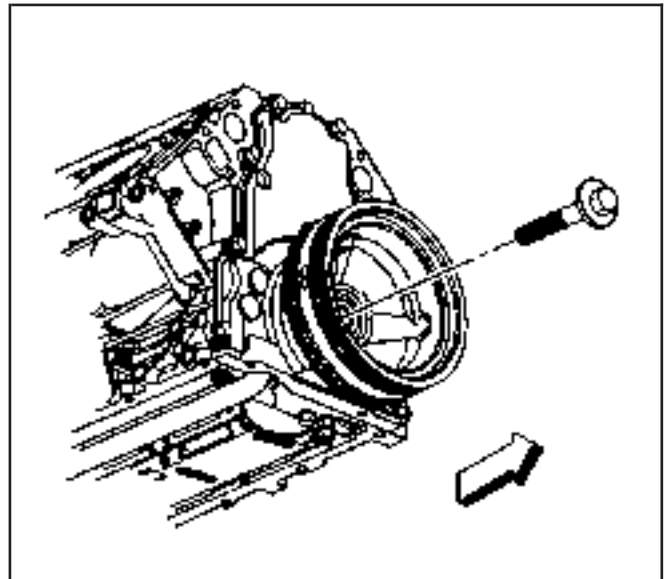
Notice: Refer to *Fastener Notice* in Cautions and Notices.

5. Install the *J 42386-A* and bolts.
Use one M10-1.5 x 120 mm and one M10-1.5 x 45 mm bolt for proper tool operation.

Tighten

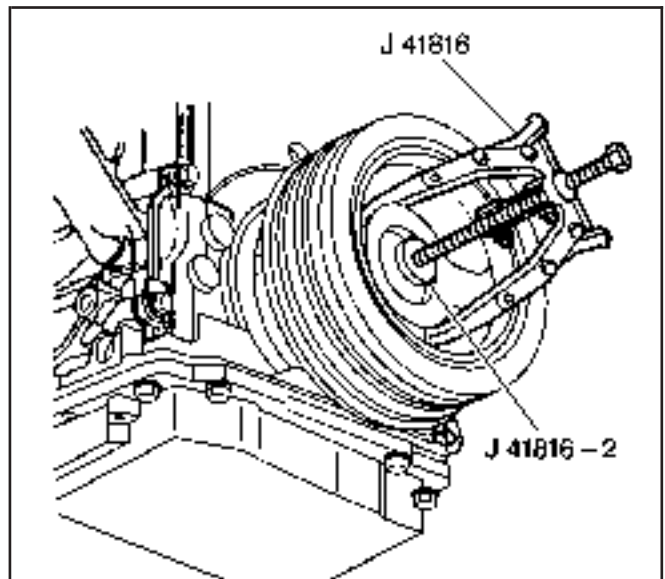
Tighten the *J 42386-A* bolts to 50 N·m (37 lb ft).

6. Remove the crankshaft balancer bolt.
Do not discard the crankshaft balancer bolt. The balancer bolt will be used during the balancer installation procedure.

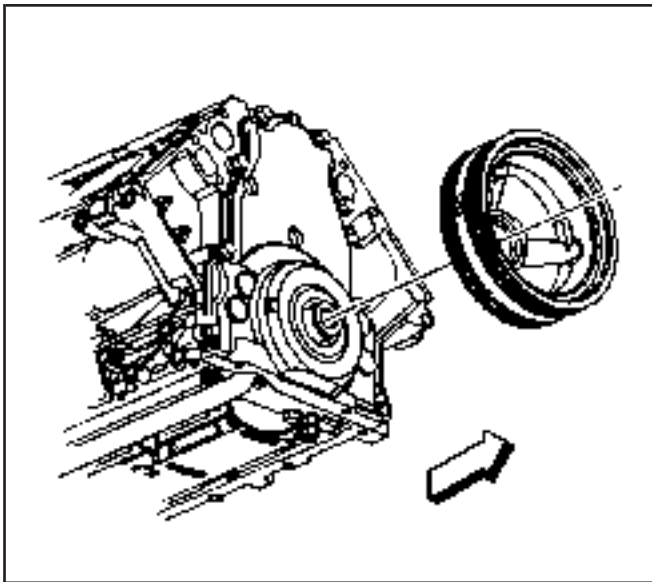


832974

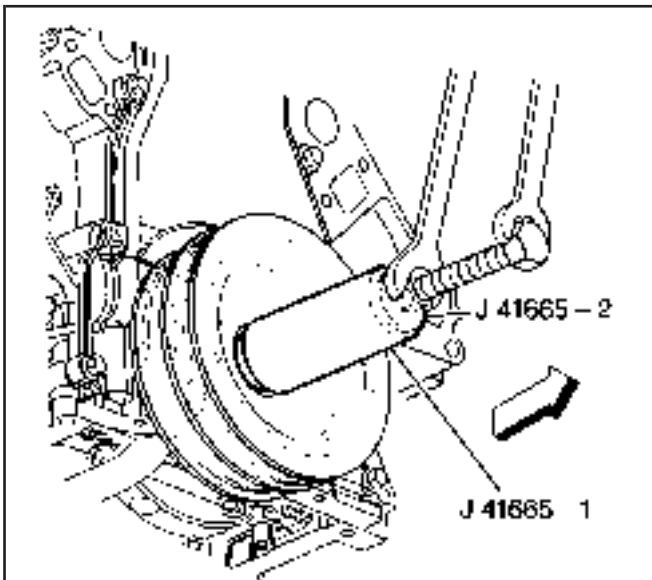
7. Install the *J 41816* and *J 41816-2* in order to remove the crankshaft balancer.
8. Remove the *J 41816* and the *J 41816-2* from the crankshaft balancer.
9. If required, clean and inspect the crankshaft balancer. Refer to *Crankshaft Balancer Cleaning and Inspection*.



156164



832975



63187

Installation Procedure

Important:

- Make sure that the teeth of *J 42386-A* mesh with the teeth of the engine flywheel.
- The used crankshaft balancer bolt will be used only during the first pass of the balancer installation procedure. Install a NEW bolt and tighten as described in the second, third and fourth passes of the balancer bolt tightening procedure.
- The crankshaft balancer installation and bolt tightening involves a four stage tightening process. The first pass ensures that the balancer is installed completely onto the crankshaft. The second, third, and fourth passes tighten the new bolt to the proper torque.

Important: The balancer should be positioned onto the end of the crankshaft as straight as possible prior to tool installation.

1. Install the crankshaft balancer onto the end of the crankshaft.
2. Use the *J 41665* in order to install the crankshaft balancer.
 - 2.1. Assemble the threaded rod, nut, washer and installer.
 - Insert the smaller end of the installer into the front of the balancer.
 - 2.2. Use a wrench and hold the hex end of the threaded rod.
 - 2.3. Use a second wrench and rotate the installation tool nut clockwise until the balancer is started onto the crankshaft.
 - 2.4. Remove the tool and reverse the installation tool.
 - Position the larger end of the installer against the front of the balancer.
 - 2.5. Use a wrench and hold the hex end of the threaded rod.
 - 2.6. Use a second wrench and rotate the installation tool nut clockwise until the balancer is installed onto the crankshaft.
 - 2.7. Remove the balancer installation tool.

3. Install the used crankshaft balancer bolt.

Tighten

Tighten the USED bolt to 330 N·m (240 lb ft).

4. Remove the used crankshaft balancer bolt.

Important: The nose of the crankshaft should be recessed 2.4–4.48 mm (0.094-0.176 in) into the balancer bore.

5. Measure for a correctly installed balancer.

If the balancer is not installed to the proper dimensions, install the *J 41665* and repeat the installation procedure.

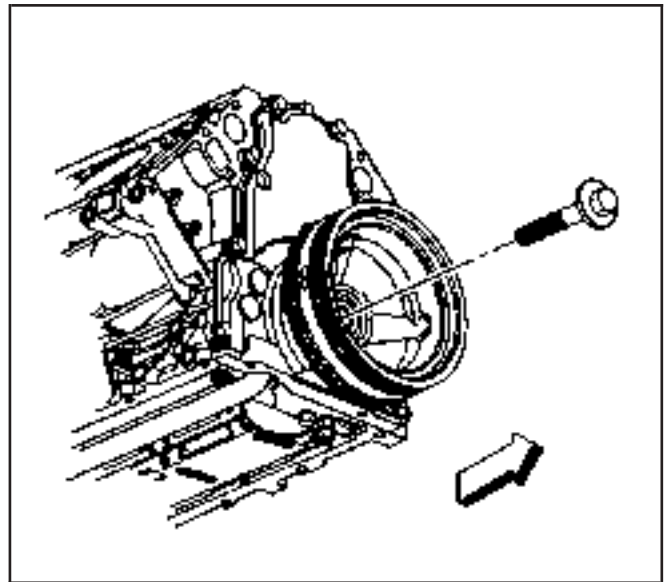
6. Install a NEW crankshaft balancer bolt.

Tighten

6.1. Tighten the bolt a first pass to 50 N·m (37 lb ft).

6.2. Tighten the bolt a second pass to 140 degrees using *J 36660-A*.

7. Remove the *J 42386-A* and bolts.
8. Install the starter motor. Refer to *Starter Motor Replacement (4.8L, 5.3L, and 6.0L Engines)* or *Starter Motor Replacement (8.1L Engine)* in Engine Electrical.
9. Install the fan shroud - lower. Refer to *Fan Shroud Replacement - Lower* in Engine Cooling.
10. Install the accessory drive belt (if not equipped with A/C). Refer to *Drive Belt Replacement - Accessory*.
11. Install the A/C drive belt (if equipped). Refer to *Drive Belt Replacement - Air Conditioning*.
12. Perform the crankshaft position (CKP) system variation learn procedure. Refer to *CKP System Variation Learn Procedure* in Engine Controls – 4.8L, 5.3L, and 6.0L.



832974

Crankshaft Front Oil Seal Replacement

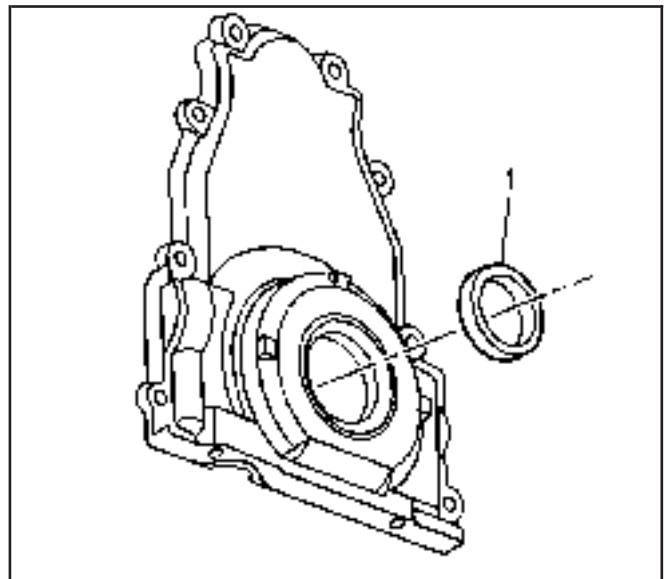
SIE-ID = 642570 LMD = 28-feb-2000

Tools Required

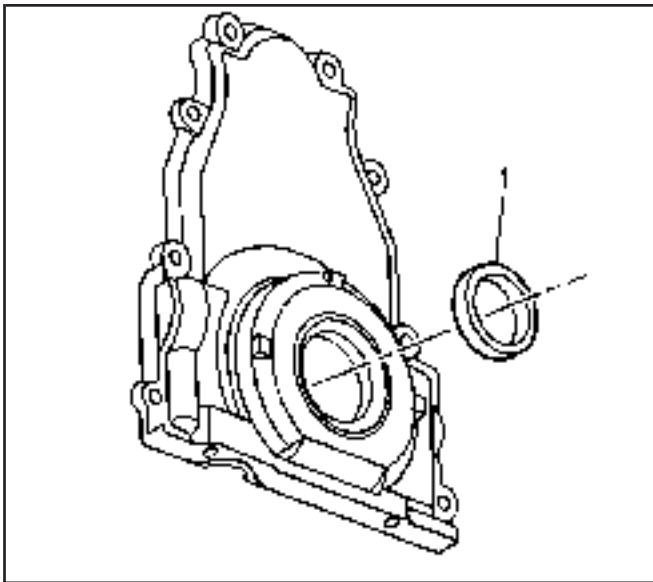
J 41478 Crankshaft Front Oil Seal Installer

Removal Procedure

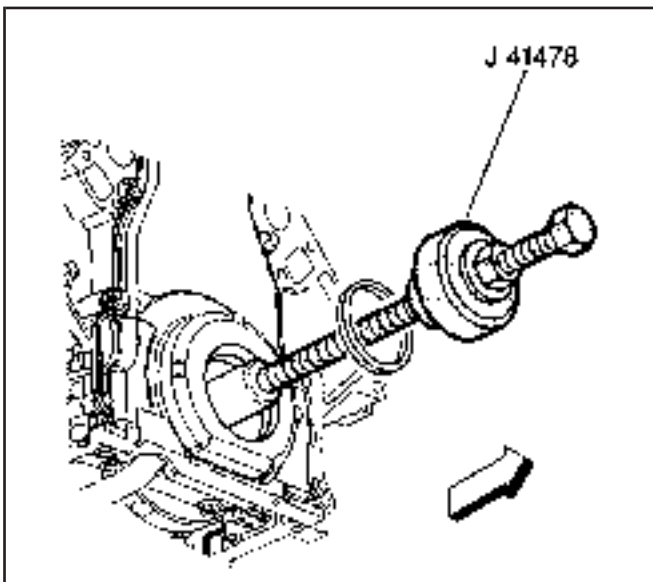
1. Remove the crankshaft balancer. Refer to *Crankshaft Balancer Replacement*.
2. Remove the crankshaft oil seal (1) from the front cover.



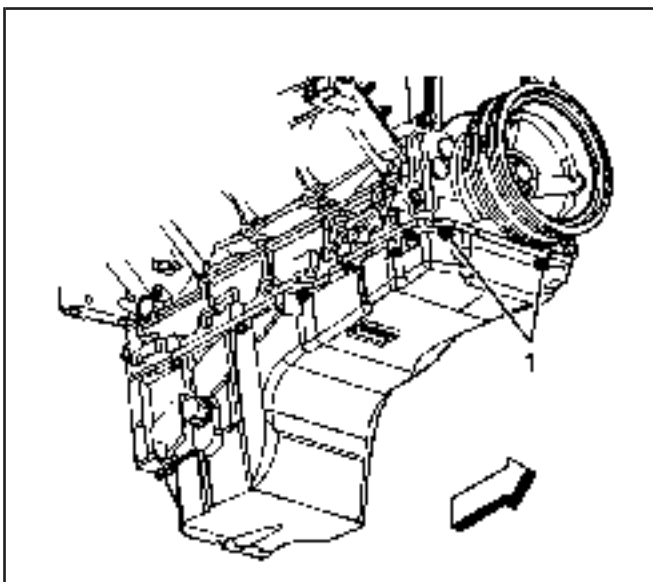
490689



490689



63177



832976

Installation Procedure

Important:

- Do not lubricate the oil seal sealing surface.
- Do not reuse the crankshaft oil seal.

1. Lubricate the outer edge of the oil seal (1) with clean engine oil.
2. Lubricate the front cover oil seal bore with clean engine oil.
3. Install the crankshaft front oil seal onto the *J 41478* guide.
4. Install the *J 41478* threaded rod (with nut, washer, guide, and oil seal) into the end of the crankshaft.
5. Use the *J 41478* in order to install the oil seal into the cover bore.
 - 5.1. Use a wrench and hold the hex on the installer bolt.
 - 5.2. Use a second wrench and rotate the installer nut clockwise until the seal bottoms in the cover bore.
 - 5.3. Remove the *J 41478*.
 - 5.4. Inspect the oil seal for proper installation. The oil seal should be installed evenly and completely into the front cover bore.
6. Install the crankshaft balancer. Refer to *Crankshaft Balancer Replacement*.

Engine Front Cover Replacement

SIE-ID = 824736 LMD = 11-feb-2002

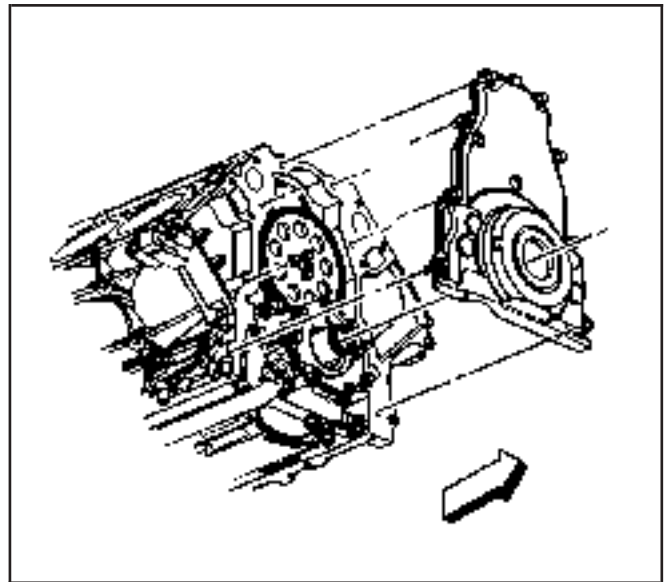
Tools Required

J 41476 Front and Rear Cover Alignment—at crankshaft seal area

Removal Procedure

1. Remove the water pump. Refer to *Water Pump Replacement (4.8L, 5.3L, and 6.0L Engines)* or *Water Pump Replacement (8.1L Engine)* in Engine Cooling.
2. Remove the crankshaft balancer. Refer to *Crankshaft Balancer Replacement*.
3. Remove the oil pan-to-front cover bolts (1).

4. Remove the front cover bolts.
5. Remove the front cover and gasket.
6. Discard the front cover gasket.
7. If required, clean and inspect the engine front cover. Refer to *Engine Front Cover Cleaning and Inspection*.

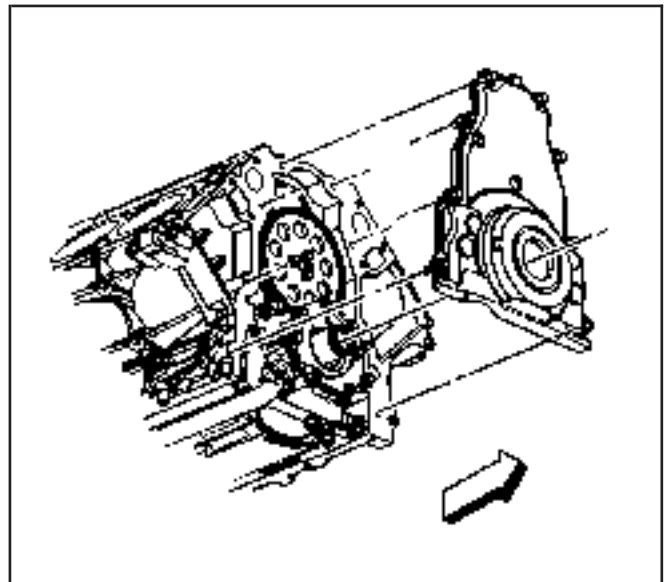


832977

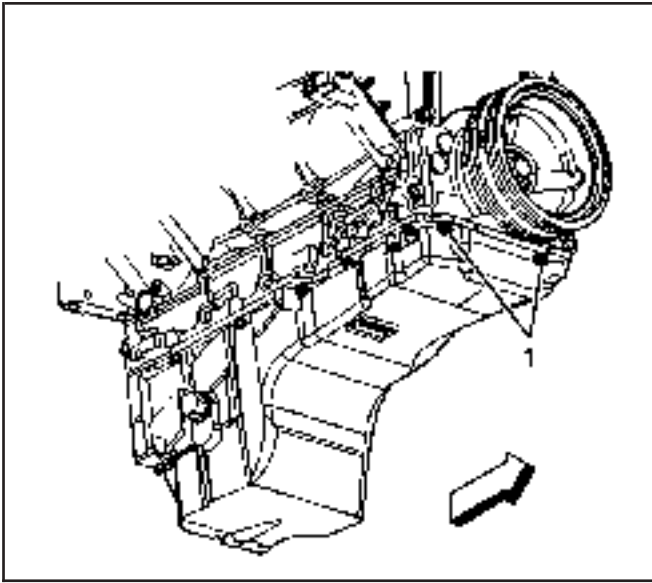
Installation Procedure

Important:

- Do not reuse the crankshaft oil seal or front cover gasket.
 - Do not apply any type of sealant to the front cover gasket, unless specified.
 - The special tool in this procedure is used to properly center the front crankshaft front oil seal.
 - All gasket surfaces should be free of oil or other foreign material during assembly.
 - The crankshaft front oil seal **MUST** be centered in relation to the crankshaft.
 - An improperly aligned front cover may cause premature front oil seal wear and/or engine oil leaks.
1. Apply a 5 mm (0.20 in) bead of sealant GM P/N 12378190, or equivalent 20 mm (0.80 in) long to the oil pan to engine block junction.
 2. Install the front cover gasket and cover.
 3. Install the front cover bolts until snug. Do not overtighten.

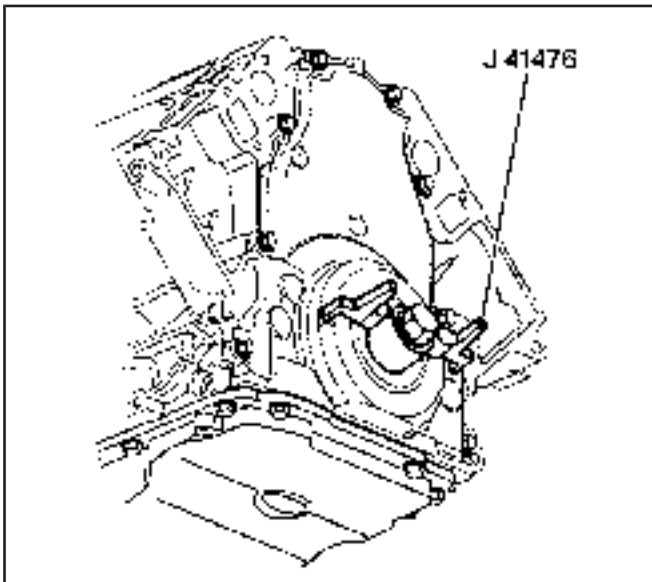


832977



832976

4. Install the oil pan-to-front cover bolts (1) until snug. Do not over tighten.



451712

5. Install *J 41476* to the front cover.
6. Align the tapered legs of the *J 41476* with the machined alignment surfaces on the front cover.

Notice: Refer to *Fastener Notice* in Cautions and Notices.

7. Install the crankshaft balancer bolt until snug. Do not overtighten.

Tighten

- 7.1. Tighten the oil pan to front cover bolts to 25 N·m (18 lb ft).
- 7.2. Tighten the engine front cover bolts to 25 N·m (18 lb ft).
8. Remove the *J 41476*.
9. Install a NEW crankshaft front oil seal. Refer to *Crankshaft Front Oil Seal Replacement*.
10. Install the water pump. Refer to *Water Pump Replacement (4.8L, 5.3L, and 6.0L Engines)* or *Water Pump Replacement (8.1L Engine)* in Engine Cooling.

Crankshaft Rear Oil Seal Replacement

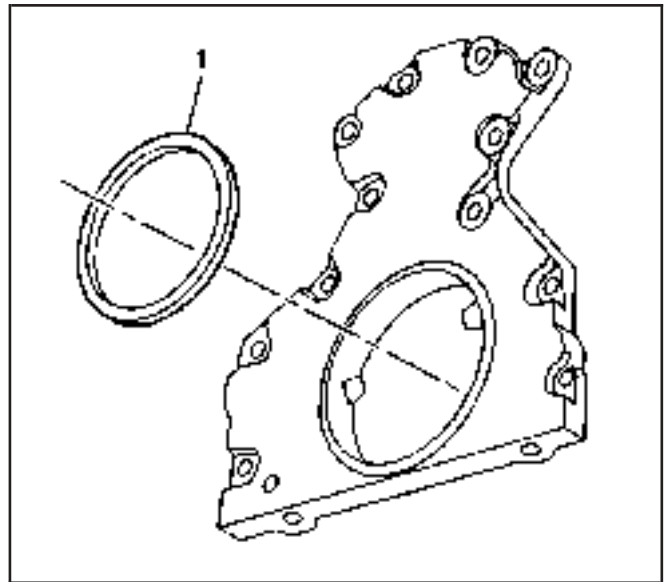
SIE-ID = 642572 LMD = 07-feb-2001

Tools Required

J 41479 Crankshaft Rear Oil Seal Installer

Removal Procedure

1. Remove the engine flywheel. Refer to *Engine Flywheel Replacement*.
2. Remove the crankshaft rear oil seal (1) from the rear cover.

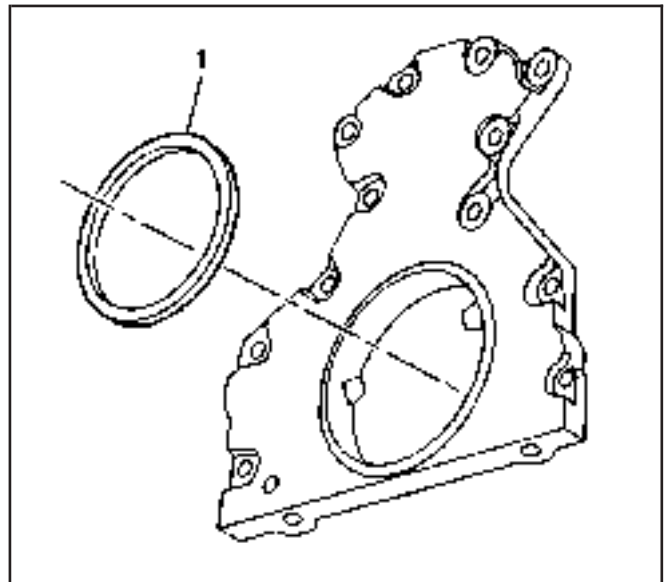


490692

Installation Procedure

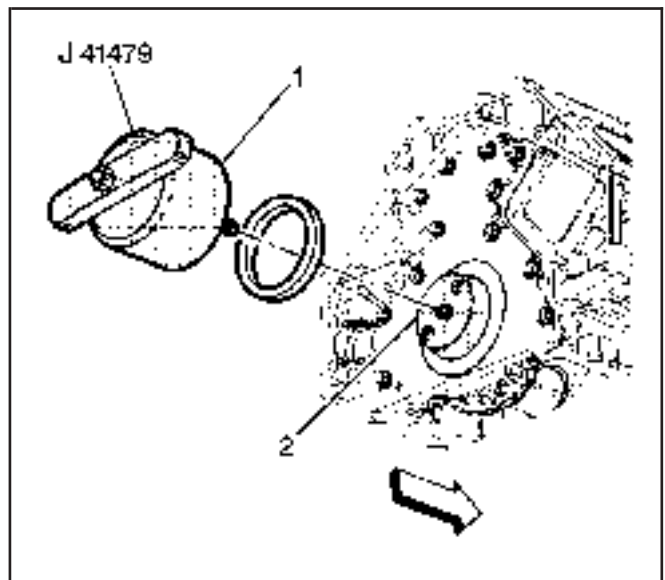
Important:

- The flywheel spacer (if applicable) must be removed prior to oil seal installation.
 - Do not lubricate the oil seal inside diameter (ID) or the crankshaft surface.
 - Do not reuse the crankshaft rear oil seal.
1. Lubricate the outside diameter (OD) of the oil seal (1) with clean engine oil.
DO NOT allow oil or other lubricants to contact the seal surface.
 2. Lubricate the rear cover oil seal bore with clean engine oil.
DO NOT allow oil or other lubricants to contact the crankshaft surface.

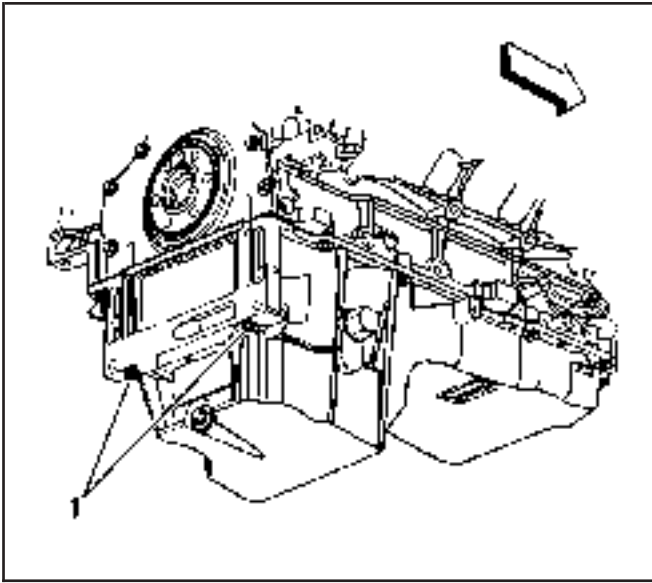


490692

3. Install the J 41479 tapered cone (2) and bolts onto the rear of the crankshaft.
4. Tighten the bolts until snug. Do not overtighten.
5. Install the rear oil seal onto the tapered cone (2) and push the seal to the rear cover bore.
6. Thread the J 41479 threaded rod into the tapered cone until the tool (1) contacts the oil seal.
7. Align the oil seal into the tool (1).
8. Rotate the handle of the tool (1) clockwise until the seal enters the rear cover and bottoms into the cover bore.
9. Remove the J 41479.
10. Install the engine flywheel. Refer to *Engine Flywheel Replacement*.



63200



680413

Engine Rear Cover Replacement

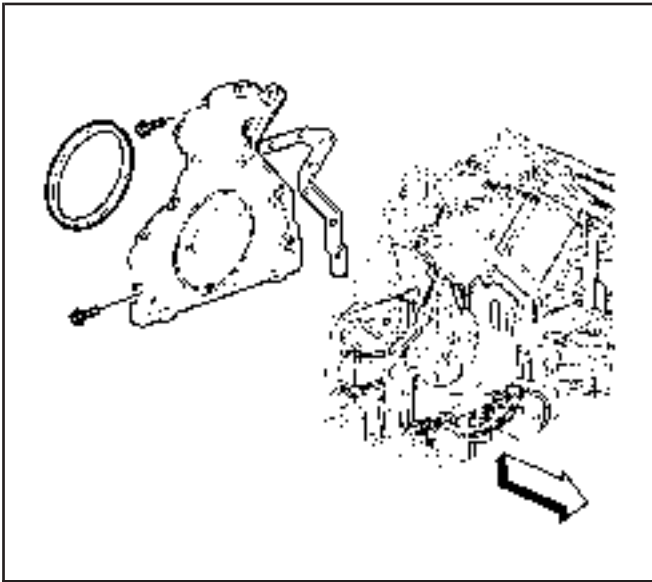
SIE-ID = 824740 LMD = 11-feb-2002

Tools Required

J 41476 Front and Rear Cover Alignment—at crankshaft seal area

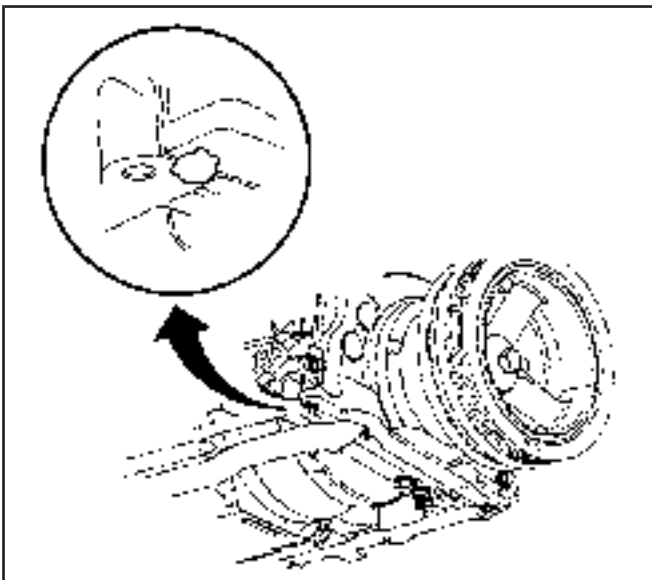
Removal Procedure

1. Remove the engine flywheel. Refer to *Engine Flywheel Replacement*.
2. Remove the oil pan-to-rear cover bolts (1).



64282

3. Remove the rear cover bolts.
4. Remove the rear cover and gasket.
5. Discard the rear cover gasket.
6. If required, clean and inspect the rear cover. Refer to *Engine Rear Cover Cleaning and Inspection*.



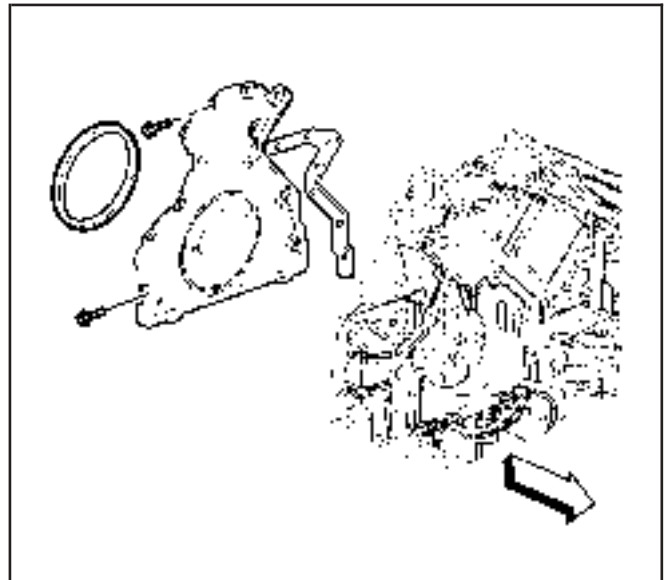
451897

Installation Procedure

Important:

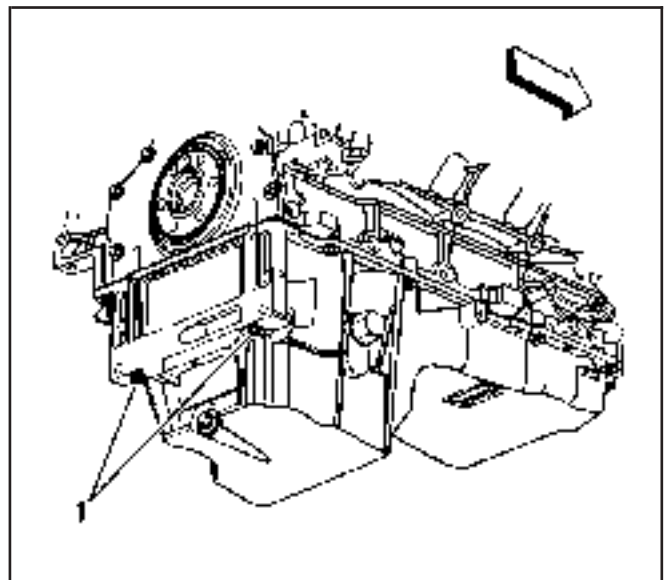
- Do not reuse the crankshaft oil seal or rear cover gasket.
 - Do not apply any type of sealant to the rear cover gasket, unless specified.
 - The special tool in this procedure is used to properly center the crankshaft rear oil seal.
 - The crankshaft rear oil seal will be installed after the rear cover has been installed and aligned.
- Install the rear cover without the crankshaft oil seal.
- All gasket surfaces should be free of oil or other foreign material during assembly.
 - The crankshaft rear oil seal **MUST** be centered in relation to the crankshaft.

- An improperly aligned rear cover may cause premature rear oil seal wear and/or engine assembly oil leaks.
1. Apply a 5 mm (0.20 in) bead of sealant GM P/N 12378190, or equivalent 20 mm (0.80 in) long to the oil pan to engine block junction.
 2. Install the rear cover gasket and cover.
 3. Install the rear cover bolts until snug. Do not overtighten.

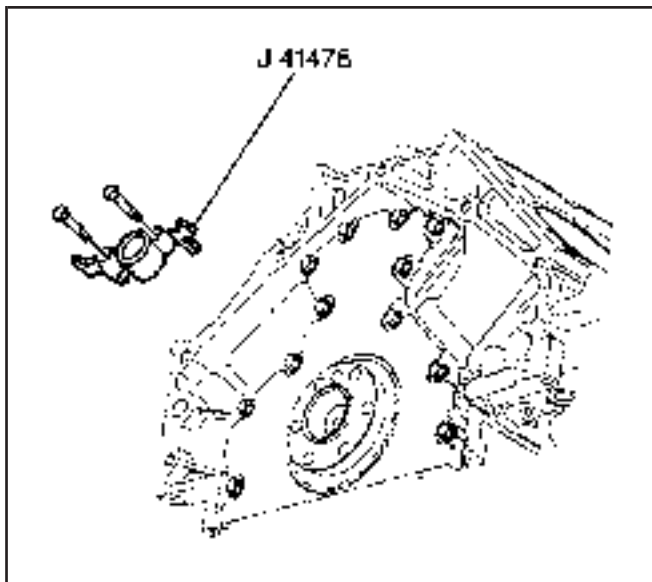


64282

4. Install the oil pan-to-rear cover bolts (1) until snug. Do not overtighten.



680413



451716

5. Rotate the crankshaft until two opposing flywheel bolt holes are parallel to the oil pan surface.

Important: The tapered legs of the alignment tool must enter the rear cover oil seal bore.

6. Install the *J 41476* and bolts onto the rear of the crankshaft.

Notice: Refer to *Fastener Notice* in Cautions and Notices.

7. Tighten the *J 41476* mounting bolts until snug. Do not overtighten.

Tighten

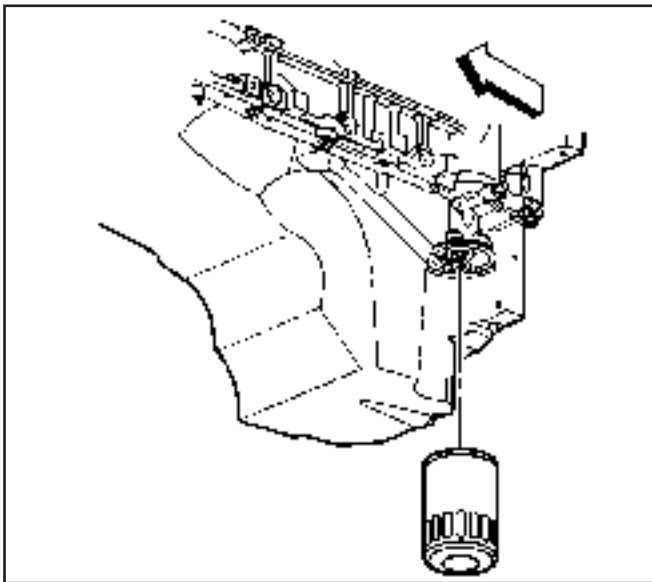
- 7.1. Tighten the oil pan-to-rear cover bolts to 12 N·m (106 lb in).
- 7.2. Tighten the engine rear cover bolts to 25 N·m (18 lb ft).
8. Remove the *J 41476*.
9. Install a NEW crankshaft rear oil seal. Refer to *Crankshaft Rear Oil Seal Replacement*.
10. Install the engine flywheel. Refer to *Engine Flywheel Replacement*.

Oil Filter Adapter Replacement

SIE-ID = 738760 LMD = 28-may-2002

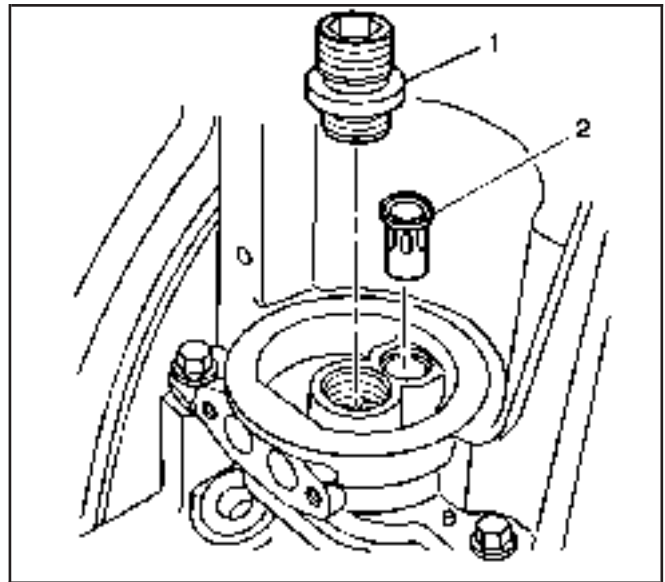
Removal Procedure

1. Drain the engine oil.
2. Remove the oil filter.



260117

3. Remove the oil filter adapter (1).



490699

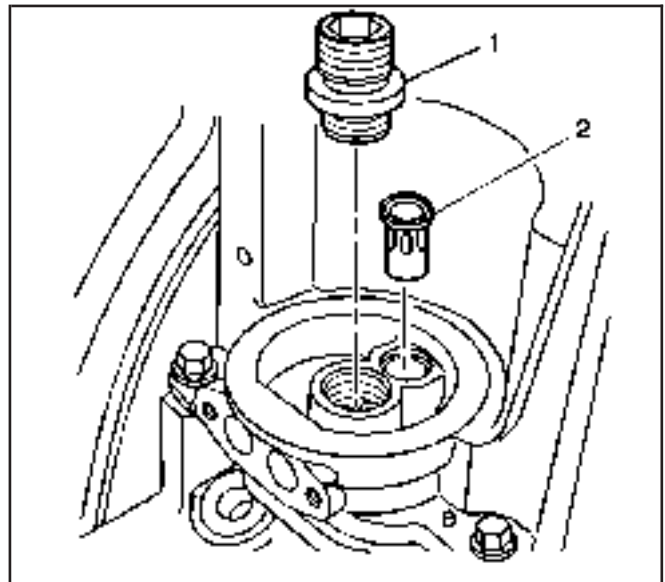
Installation Procedure

Notice: Refer to *Fastener Notice* in Cautions and Notices.

1. Install the oil filter adapter (1).

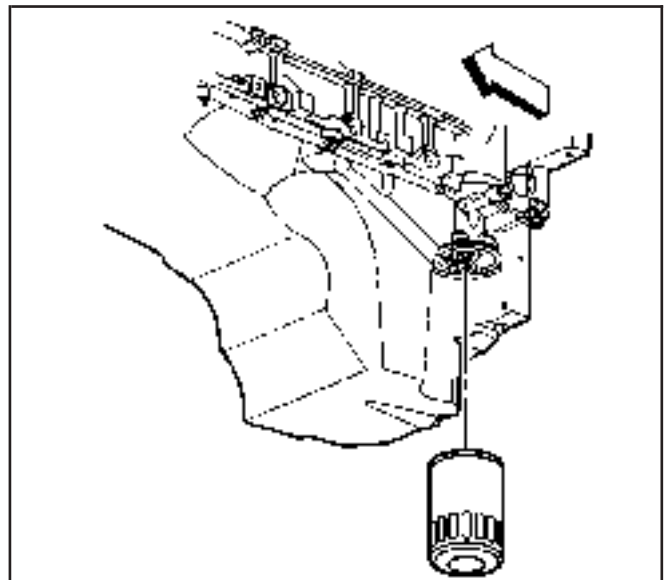
Tighten

Tighten the adapter to 55 N·m (40 lb ft).

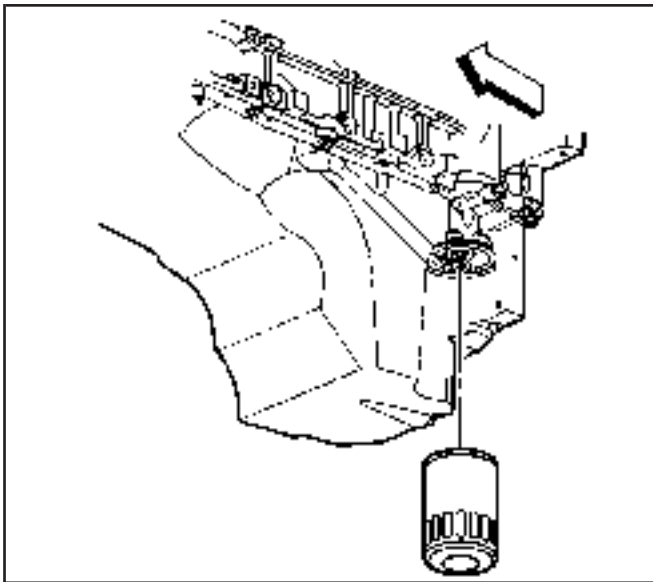


490699

2. Install the oil filter.
3. Refill the engine oil. Refer to *Capacities - Approximate Fluid and/or Fluid and Lubricant Recommendations* in Maintenance and Lubrication.



260117



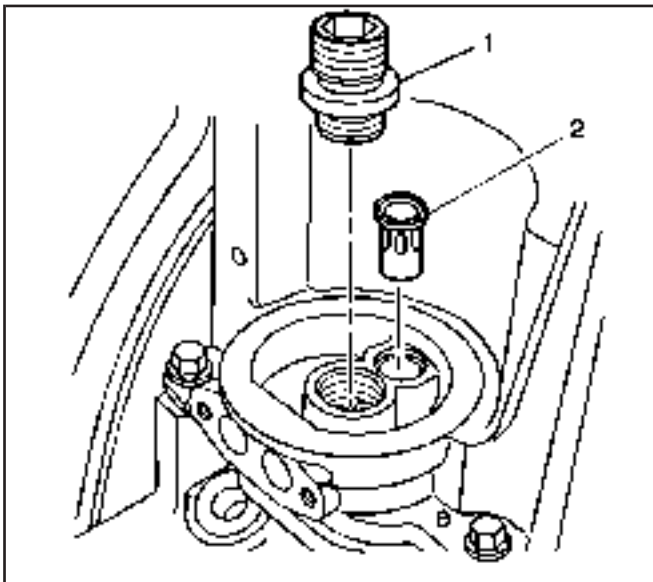
260117

Oil Filter Bypass Valve Replacement

SIE-ID = 738761 LMD = 20-jun-2001

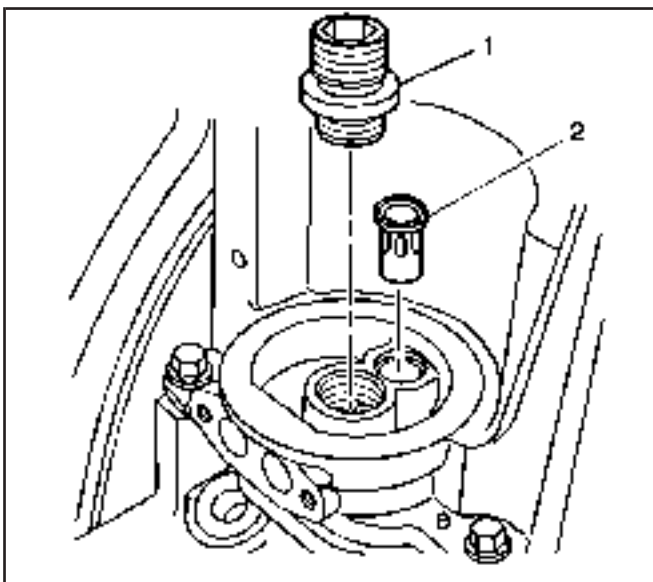
Removal Procedure

1. Drain the engine oil.
2. Remove the oil filter.



490699

3. Remove the oil filter adapter (1).
4. Remove the oil filter bypass valve (2).



490699

Installation Procedure

1. Install the oil filter bypass valve (2).

Notice: Refer to *Fastener Notice* in Cautions and Notices.

2. Install the oil filter adapter (1).

Tighten

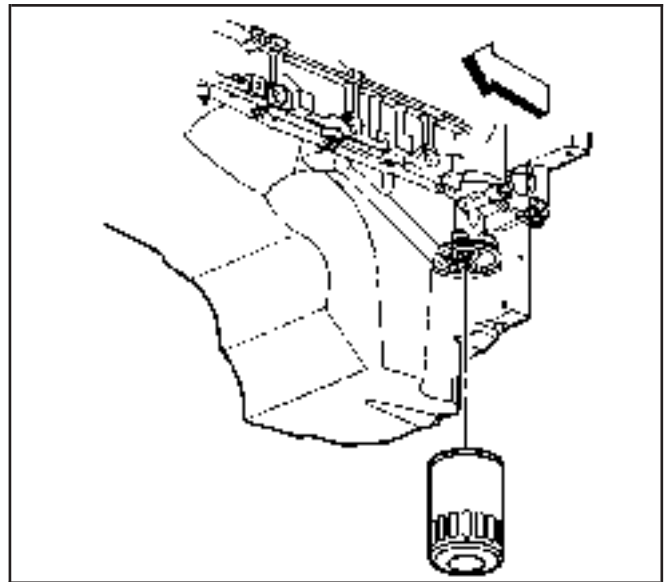
Tighten the oil filter adapter to 55 N·m (40 lb ft).

3. Install the oil filter.

Tighten

Tighten the oil filter to 30 N·m (22 lb ft).

4. Refill the engine oil. Refer to *Capacities - Approximate Fluid and/or Fluid and Lubricant Recommendations* in Maintenance and Lubrication.



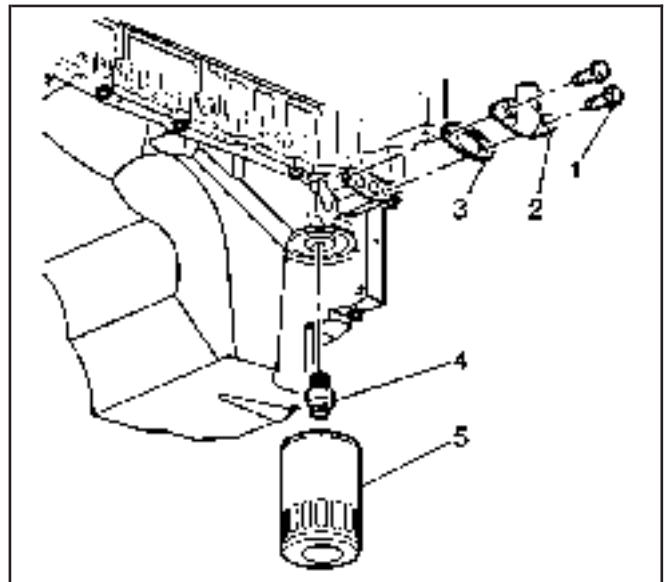
260117

Oil Pan Cover Replacement

SIE-ID = 738762 LMD = 28-may-2002

Removal Procedure

1. Drain the engine oil.
2. Remove the oil pan cover bolts (1), cover (2), and gasket (3).
3. Discard the gasket.



260125

Installation Procedure

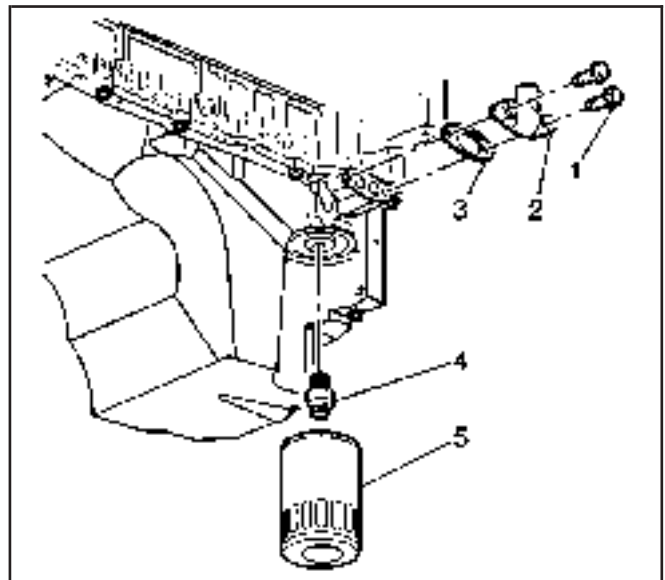
Notice: Refer to *Fastener Notice* in Cautions and Notices.

1. Install a new oil pan cover gasket (3), the cover (2) and bolts (1).

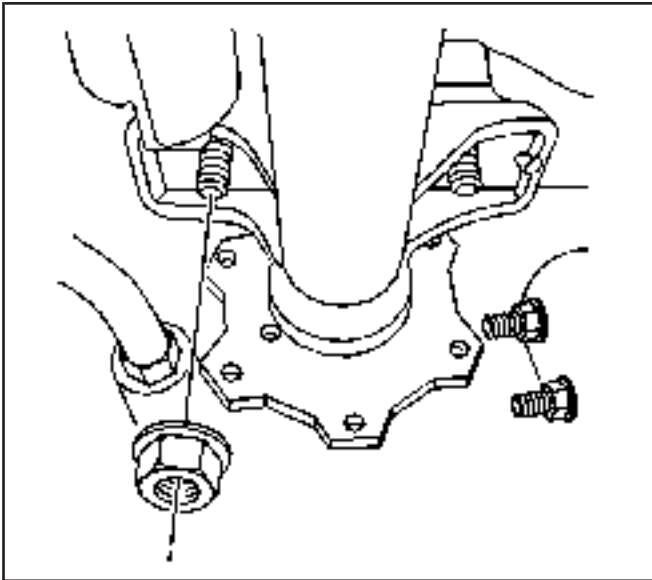
Tighten

Tighten the bolts to 12 N·m (106 lb in).

2. Refill the engine oil. Refer to *Capacities - Approximate Fluid and/or Fluid and Lubricant Recommendations* in Maintenance and Lubrication.



260125



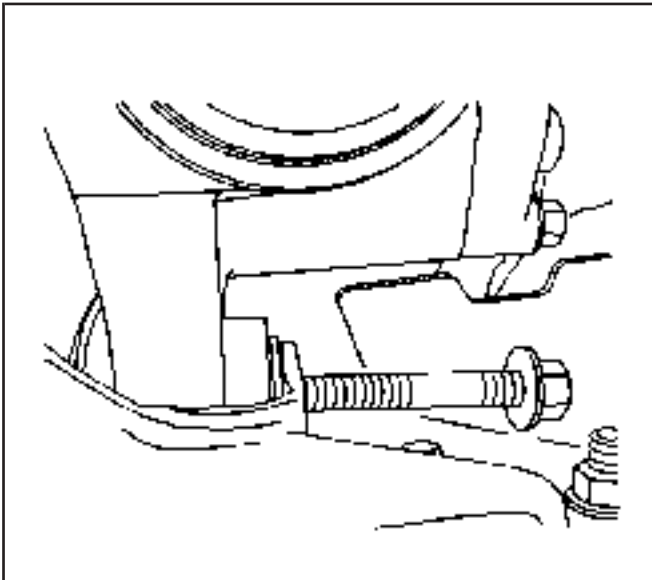
834241

Oil Pan Replacement

SIE-ID = 824744 LMD = 16-may-2002

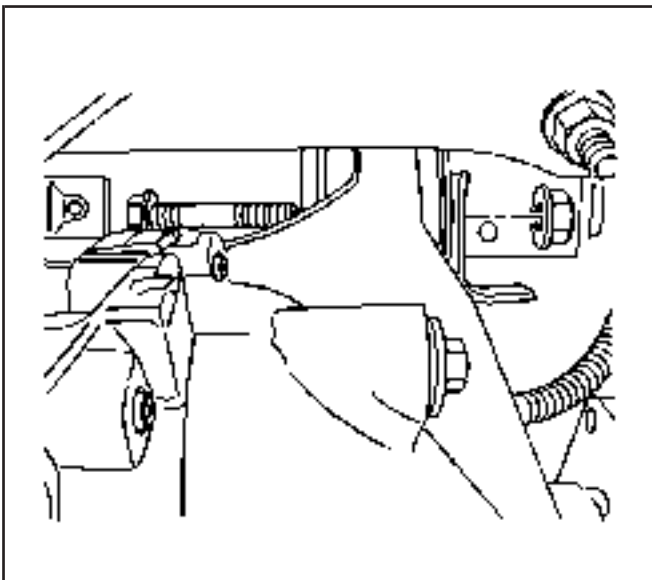
Removal Procedure

1. If equipped with four wheel drive (4WD), remove the inner axle housing nuts and washers from the bracket.
2. Support the front drive axle with a suitable jack.



834278

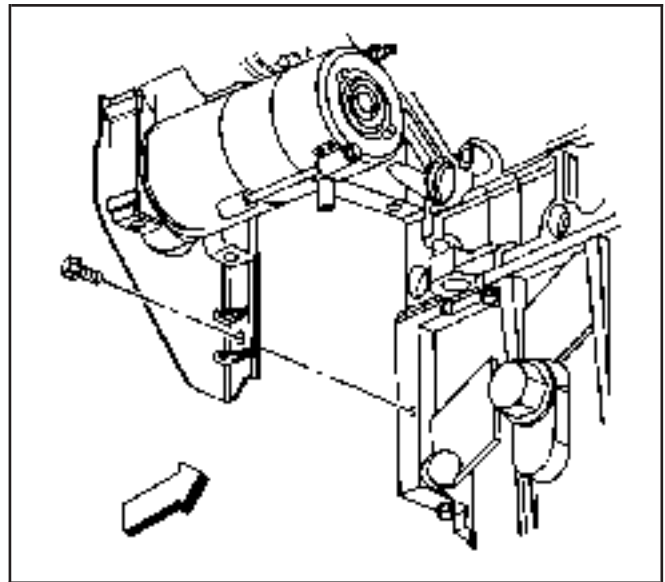
3. If equipped with 4WD, remove the differential carrier lower mounting bolt and nut.



834276

4. If equipped with 4WD, remove the differential carrier upper mounting bolt and nut.
5. Lower the front drive axle.

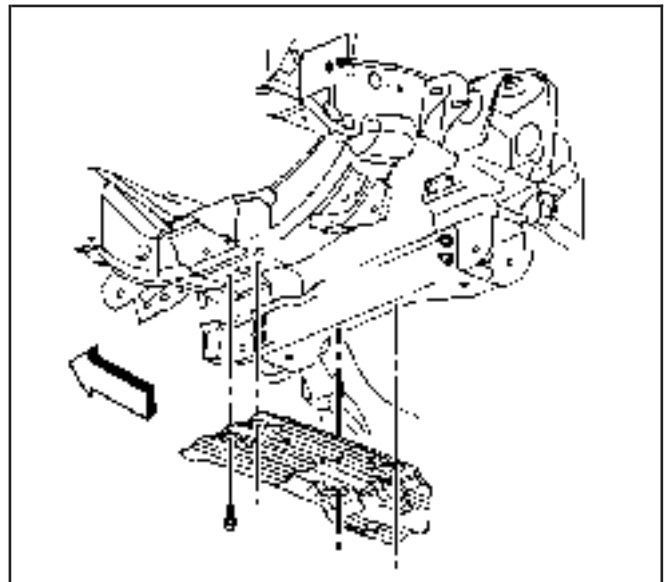
6. Remove the transmission cover bolt.



663487

7. If equipped, remove the oil pan skid plate bolts.

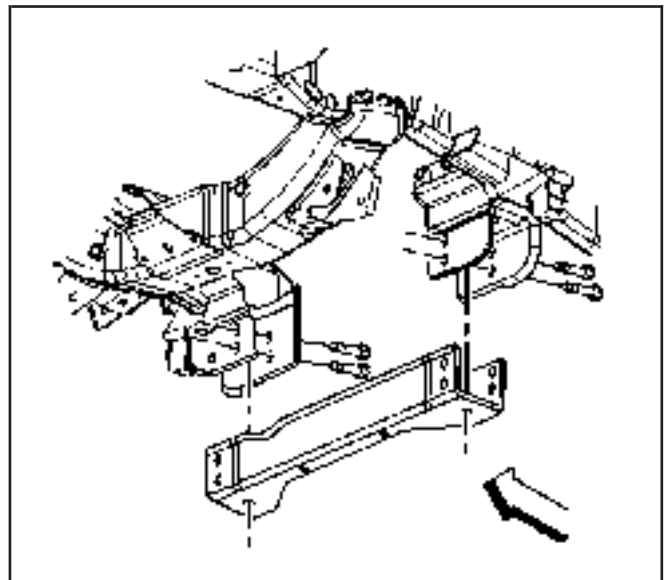
8. Remove the oil pan skid plate.



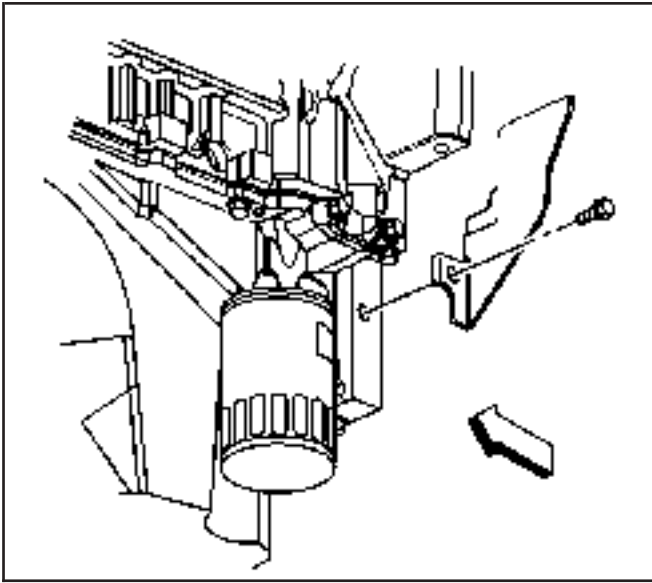
309158

9. Remove the crossbar bolts.

10. Remove the crossbar.

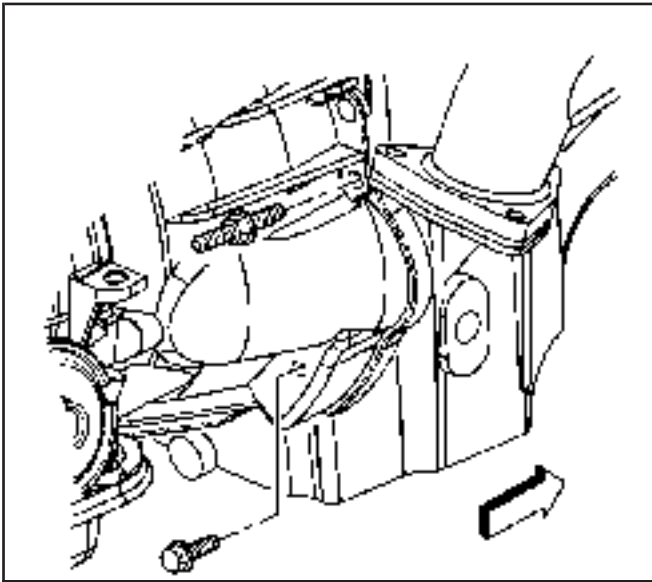


328107



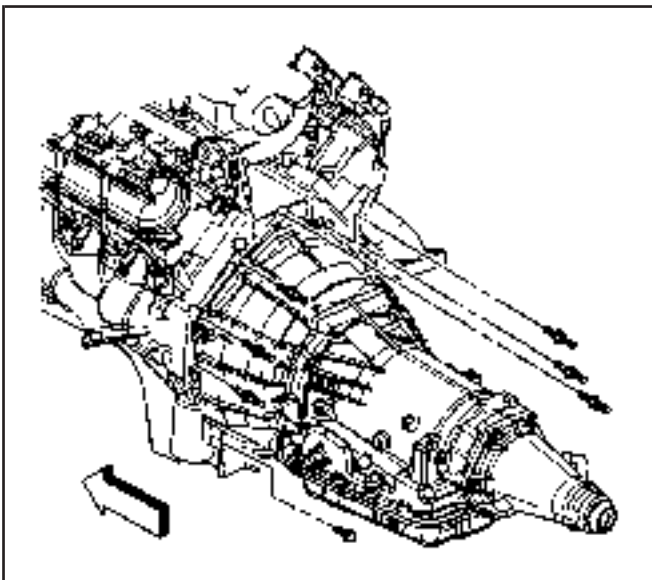
832978

11. Remove the transmission cover bolt and cover.
12. Drain the engine oil and remove the engine oil filter.
13. Re-install the drain plug and oil filter until snug.



394448

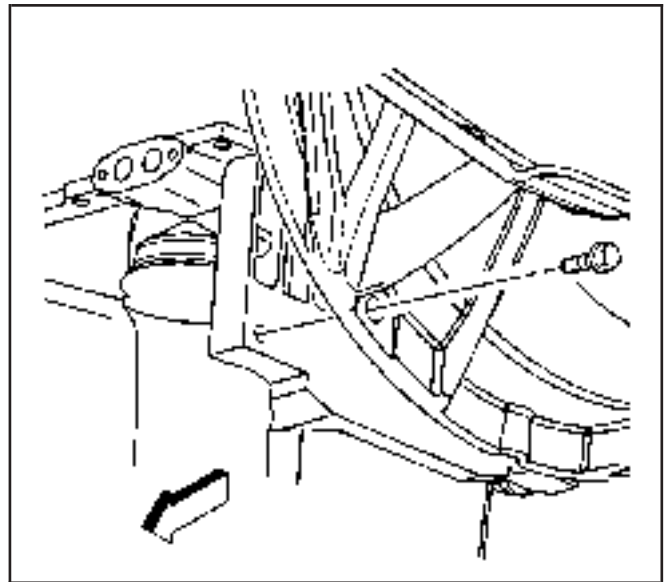
14. If equipped with the 4L60-E automatic transmission, remove the transmission bolt and stud on the right side.



394446

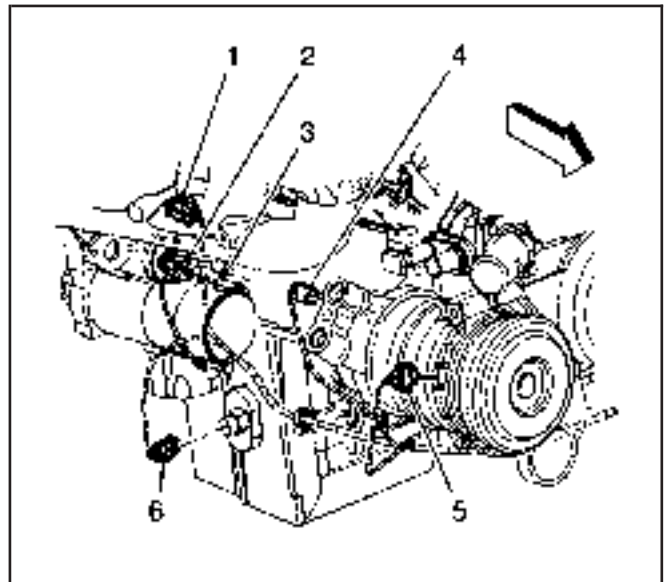
15. Remove the bottom bolt on the left side.

- 16. If equipped with the 4L80-E automatic transmission, remove the transmission converter cover bolts.



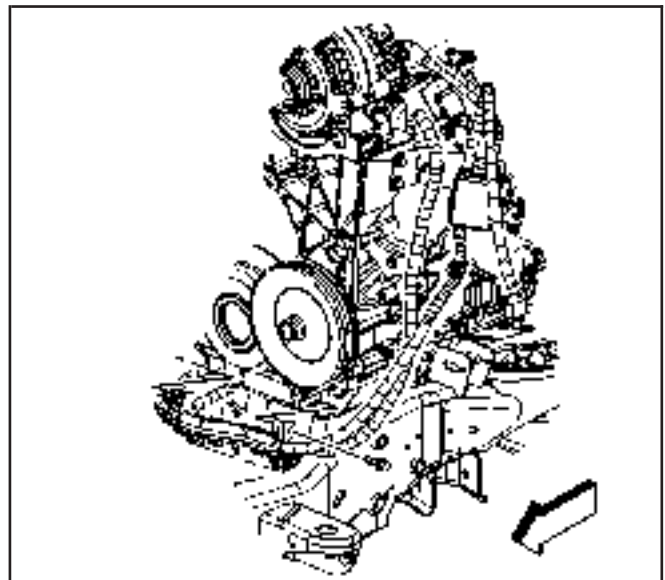
396795

- 17. Disconnect the oil level sensor electrical connector (6).

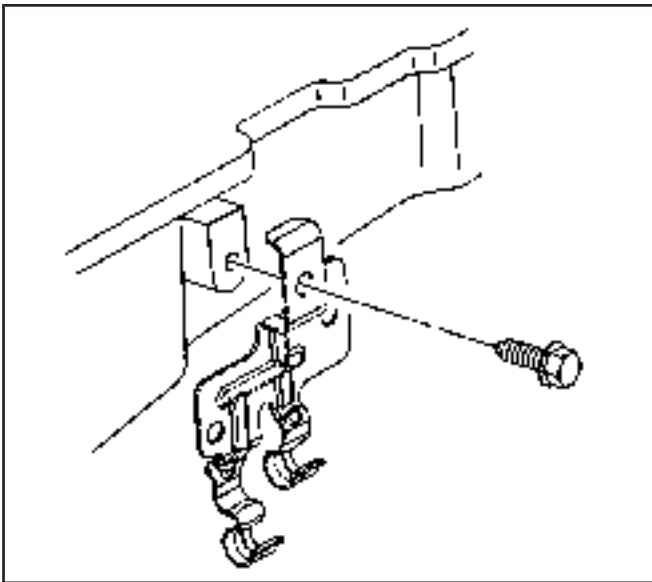


662991

- 18. Remove the battery cable channel bolt.
- 19. Slide the channel pin out of the oil pan tab.

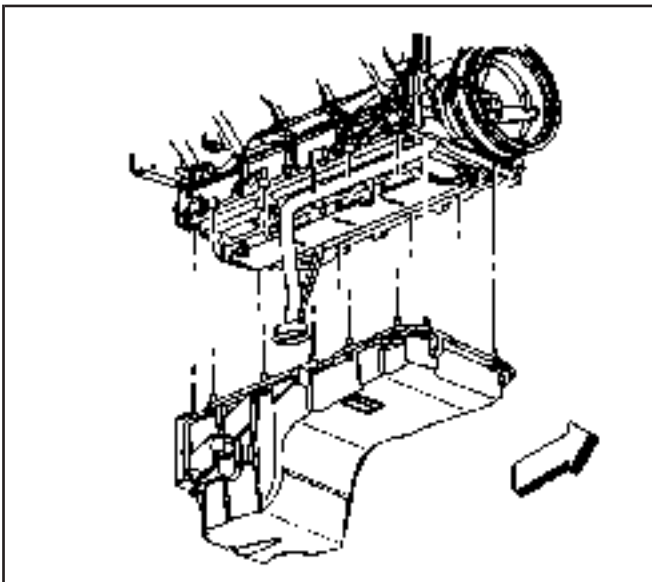


662508



310672

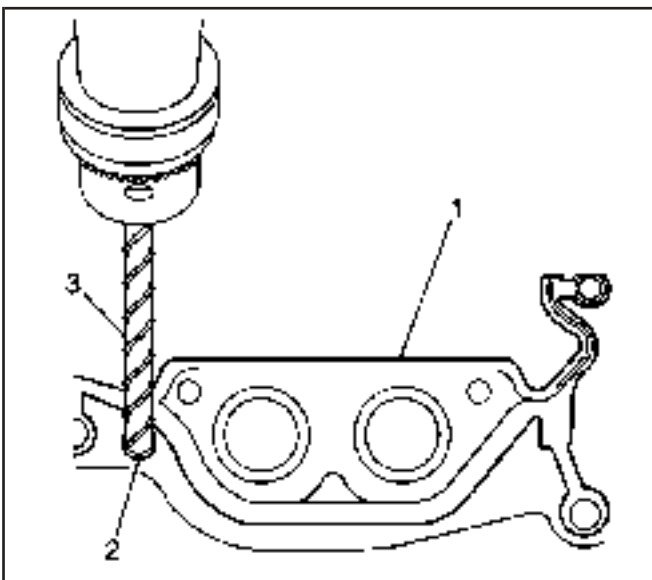
20. Remove the positive battery cable clip bolt.



683355

21. Remove the oil pan bolts.

22. Remove the oil pan.



384699

Important: DO NOT allow foreign material to enter the oil passages of the oil pan, cap or cover the openings as required.

23. Drill (3) out the oil pan gasket retaining rivets (2), if required.

24. Remove the gasket (1) from the pan.

25. Discard the gasket and rivets.

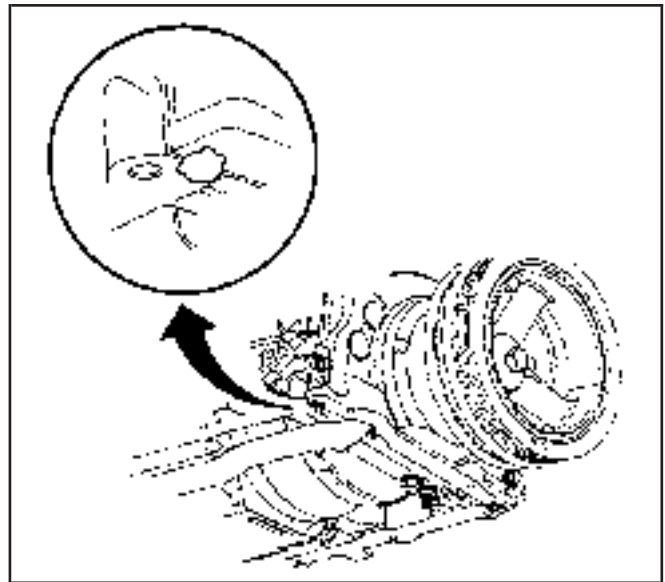
26. if require, clean and inspect the engine oil pan. Refer to *Oil Pan Cleaning and Inspection*.

Installation Procedure

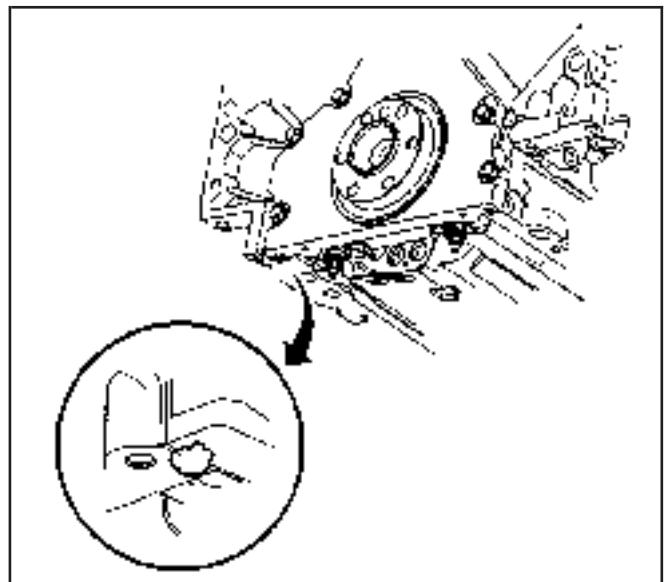
Important:

- The alignment of the structural oil pan is critical. The rear bolt hole locations of the oil pan provide mounting points for the transmission bellhousing. To ensure the rigidity of the powertrain and correct transmission alignment, it is important that the rear of the block and the rear of the oil pan must NEVER protrude beyond the engine block and transmission bellhousing plane.
 - Do not reuse the oil pan gasket.
 - It is not necessary to rivet the NEW gasket to the oil pan.
1. Apply a 5 mm (0.20 in) bead of sealant GM P/N 12378190, or equivalent 20 mm (0.80 in) long to the engine block. Apply the sealant directly onto the tabs of the front cover gasket that protrudes into the oil pan surface.

 2. Apply a 5 mm (0.20 in) bead of sealant GM P/N 12378190, or equivalent 20 mm (0.8 in) long to the engine block. Apply the sealant directly onto the tabs of the rear cover gasket that protrudes into the oil pan surface.



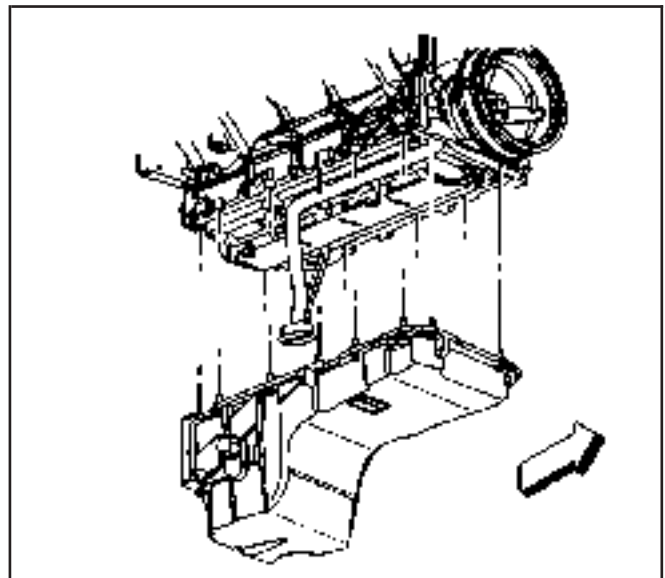
451897



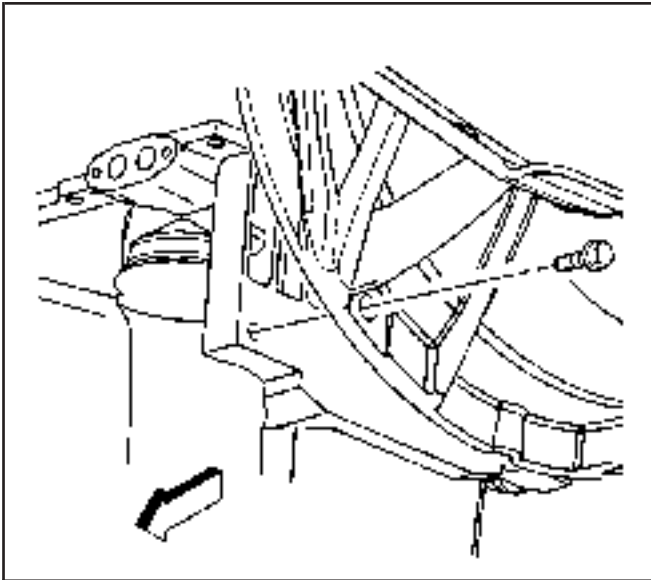
451898

Important: Be sure to align the oil gallery passages in the oil pan and engine block properly with the oil pan gasket.

3. Pre-assemble the oil pan gasket to the pan.
 - Install the gasket onto the pan.
 - Install the oil pan bolts to the pan and through the gasket.
4. Install the oil pan, gasket and bolts to the engine block.
5. Tighten the oil pan bolts until snug. Do not overtighten.

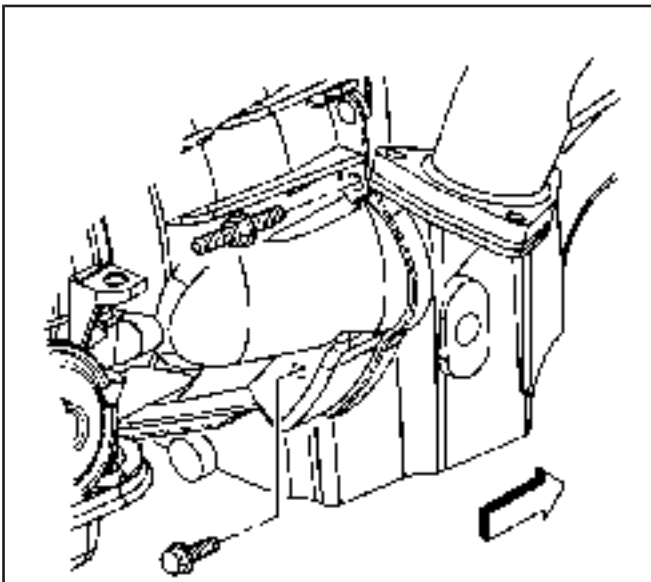


683355



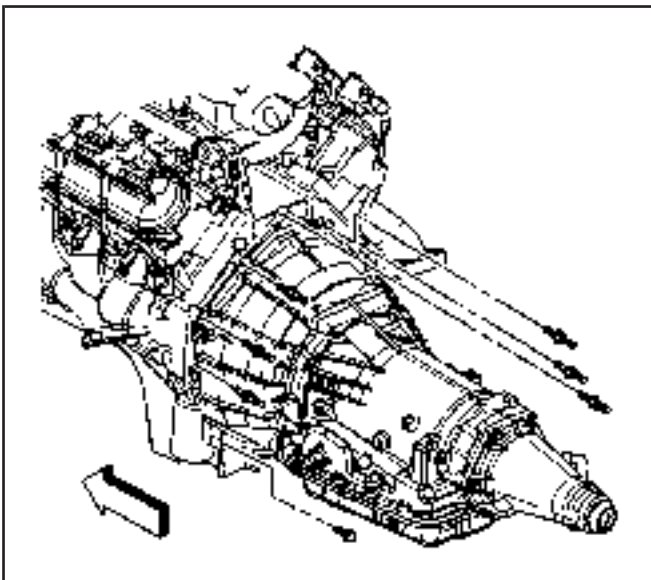
396795

6. Install the transmission converter cover bolts until snug, if equipped with the 4L80-E automatic transmission.



394448

7. Install the transmission bolt and stud on the right side until snug, If equipped with the 4L60-E automatic transmission.



394446

Notice: Refer to *Fastener Notice* in Cautions and Notices.

8. Install the bottom bolt on the left side until snug.

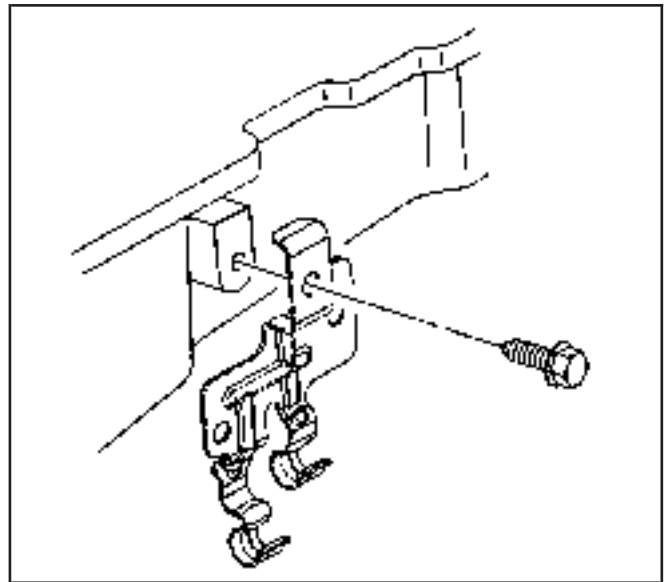
Tighten

- 8.1. Tighten the oil pan-to-front cover bolts to 25 N·m (18 lb ft).
- 8.2. Tighten the oil pan-to-rear cover bolts to 12 N·m (106 lb in).
- 8.3. Tighten the converter cover, and transmission bolts/stud to 50 N·m (37 lb ft).

9. Install the positive battery cable clip bolt.

Tighten

Tighten the bolt to 9 N·m (80 lb in).



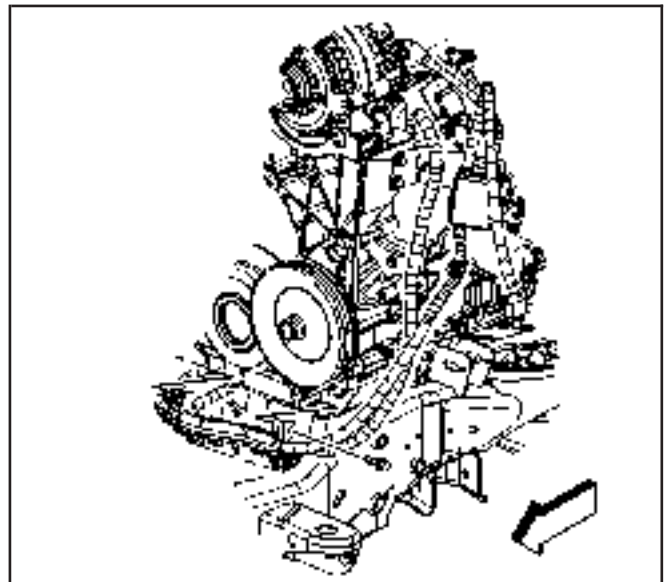
310672

10. Slide the channel pin in to the oil pan tab.

11. Install the battery cable channel bolt.

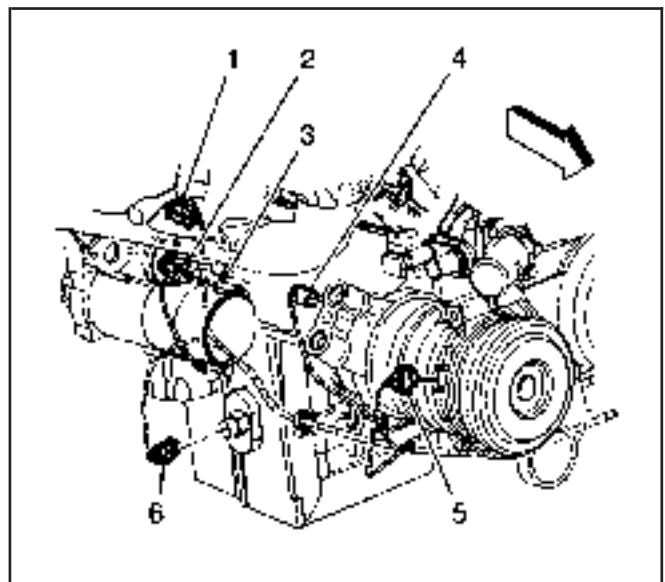
Tighten

Tighten the bolt to 12 N·m (106 lb in).

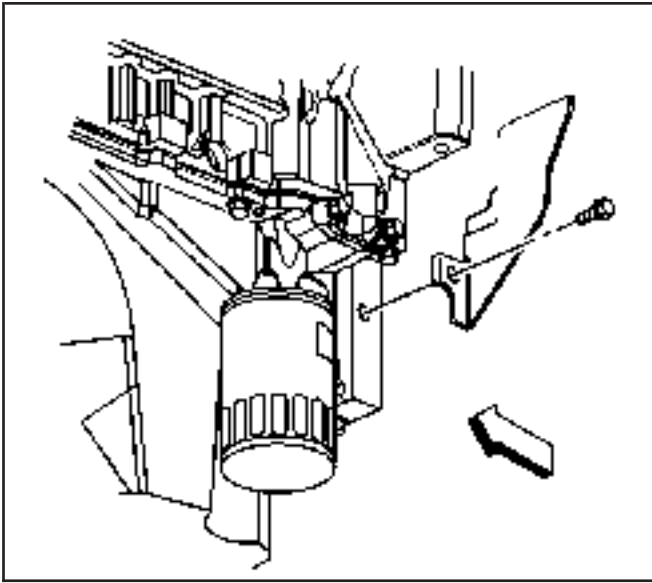


662508

12. Connect the oil level sensor electrical connector (6).



662991

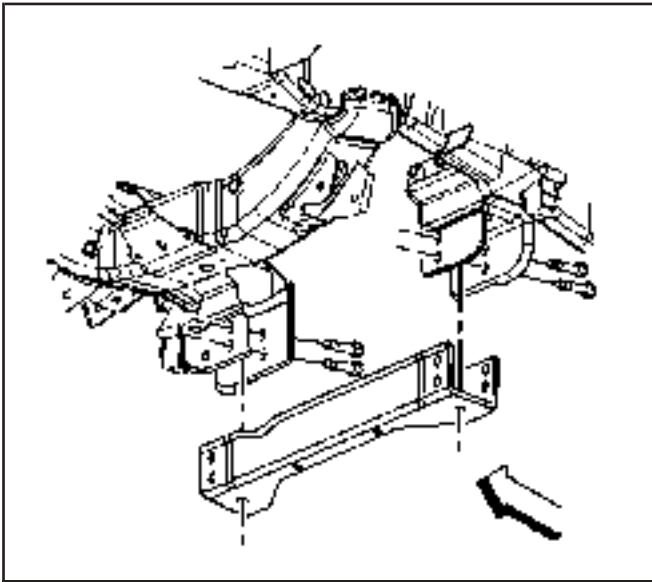


832978

13. Install the transmission cover and bolt.

Tighten

Tighten the bolt to 12 N·m (106 lb in).



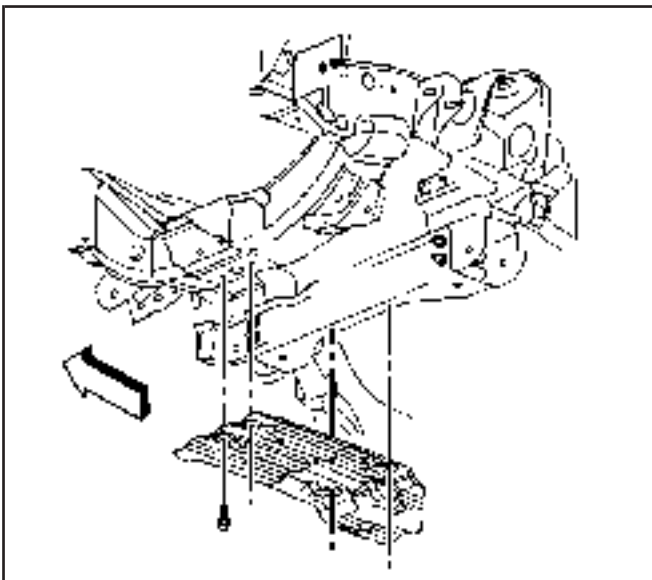
328107

14. Install the crossbar.

15. Install the crossbar bolts.

Tighten

Tighten the bolts to 100 N·m (74 lb ft).



309158

16. If equipped, install the oil pan skid plate.

17. Install the oil pan skid plate bolts.

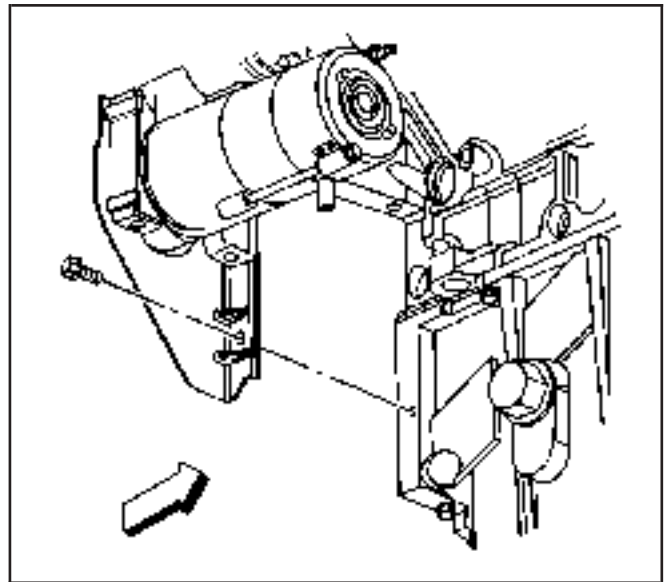
Tighten

Tighten the bolts to 20 N·m (15 lb ft).

18. Install the transmission cover bolt.

Tighten

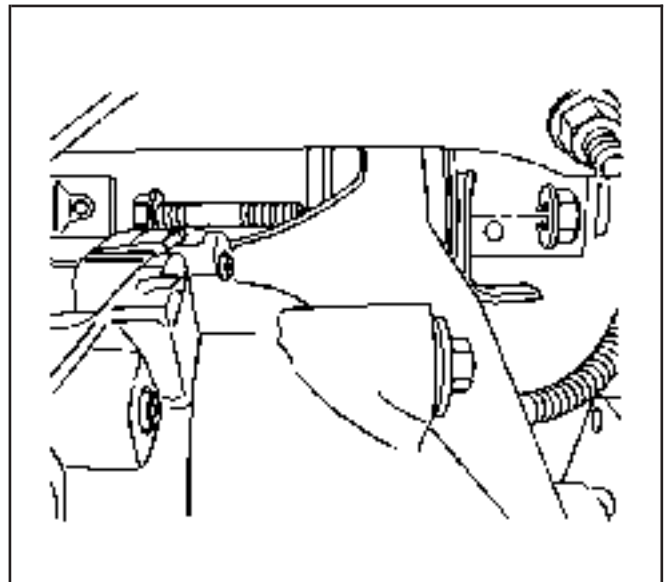
Tighten the bolt to 12 N·m (106 lb in).



663487

19. Raise the front drive axle into position.

20. If equipped with 4WD, install the differential carrier upper mounting bolt and nut until snug. Do not tighten at this time.

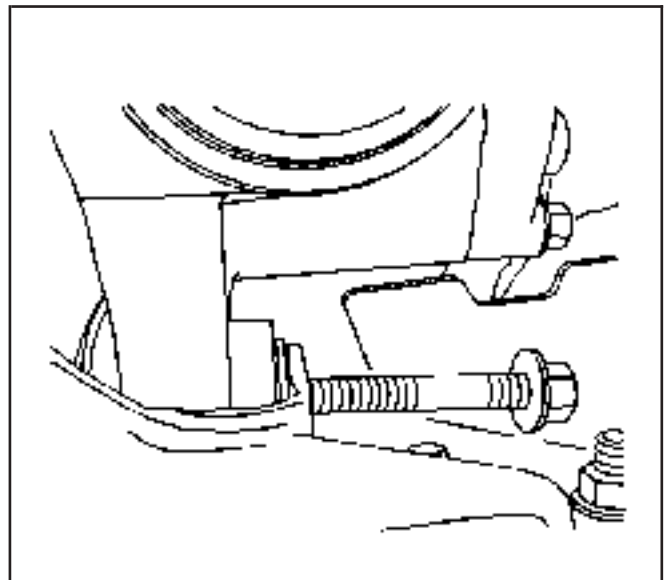


834276

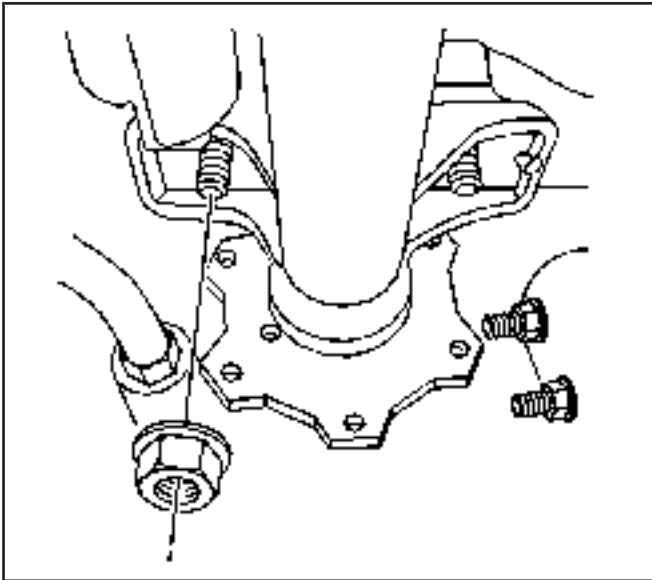
21. If equipped with 4WD, install the differential carrier lower mounting bolt and nut.

Tighten

Tighten the bolts to 100 N·m (75 lb ft).



834278



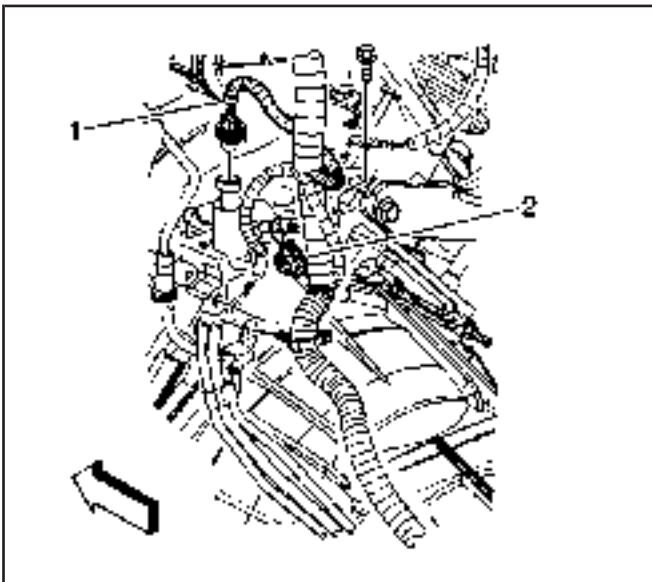
834241

22. If equipped with 4WD, install the inner axle housing washers and nuts to the bracket.

Tighten

Tighten the nuts to 100 N·m (75 lb ft).

23. Remove the jack from the front drive axle.
24. Install new engine oil and a new oil filter. Refer to *Engine Oil and Oil Filter Replacement*.



684224

Engine Oil Pressure Sensor and/or Switch Replacement

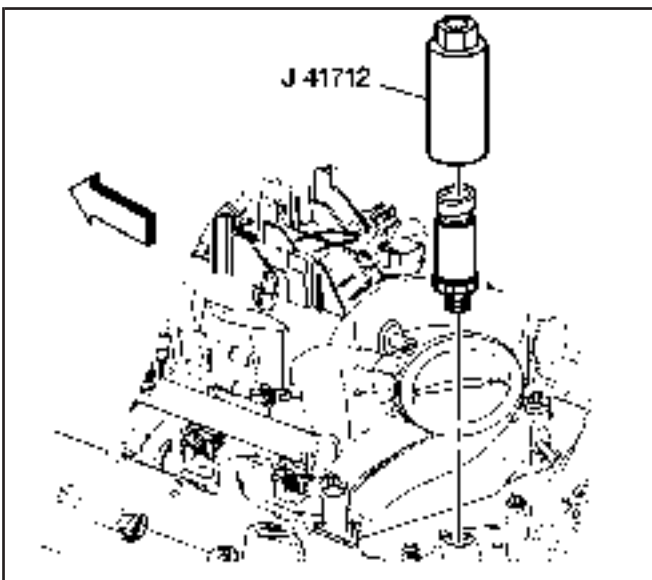
SIE-ID = 763185 LMD = 28-may-2002

Tools Required

J 41712 Oil Pressure Switch Socket

Removal Procedure

1. If necessary, remove the engine sight shield. Refer to *Engine Sight Shield Replacement (4.8L, 5.3L, and 6.0L (RPO LQ4))* or *Engine Sight Shield Replacement (6.0L (RPO LQ9))*.
2. Disconnect the oil pressure sensor electrical connector (1).
3. Using J 41712 or equivalent, remove the oil pressure sensor.



260089

Installation Procedure

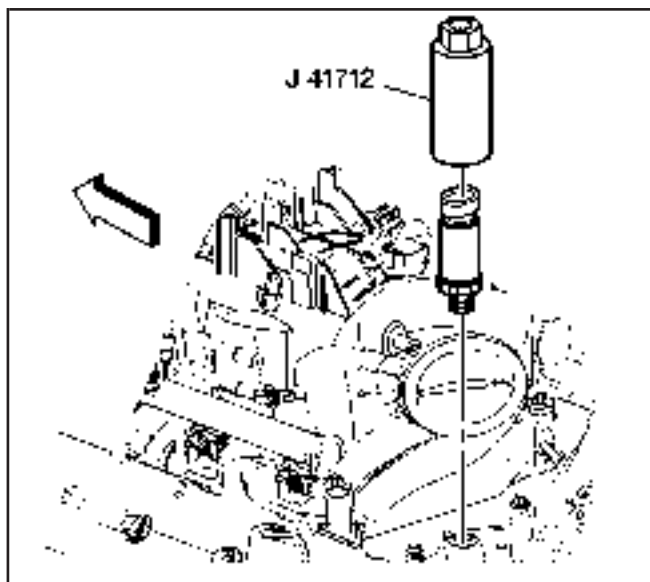
1. Apply sealant GM P/N 12346004, (Canadian P/N 10953480), or equivalent, to the threads of the oil pressure sensor.

Notice: Refer to *Fastener Notice* in Cautions and Notices.

2. Using J 41712 or equivalent, install the oil pressure sensor.

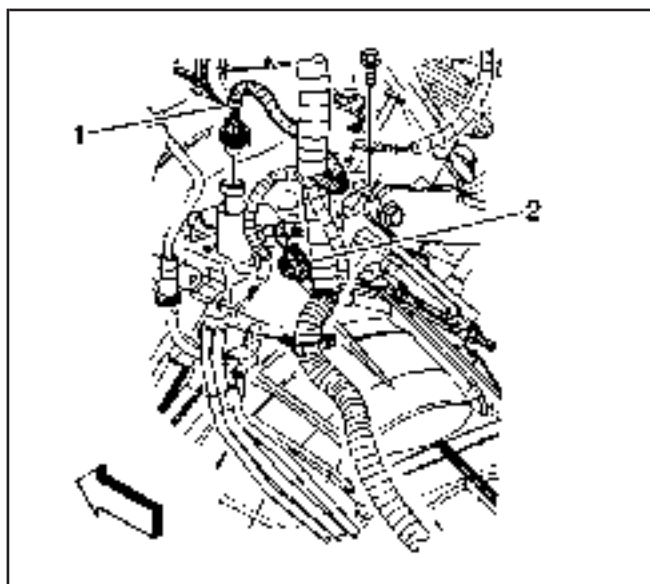
Tighten

Tighten the oil pressure sensor to 20 N·m (15 lb ft).



260089

3. Connect the oil pressure sensor electrical connector (1).
4. If necessary, install the engine sight shield. Refer to *Engine Sight Shield Replacement (4.8L, 5.3L, and 6.0L (RPO LQ4))* or *Engine Sight Shield Replacement (6.0L (RPO LQ9))*.



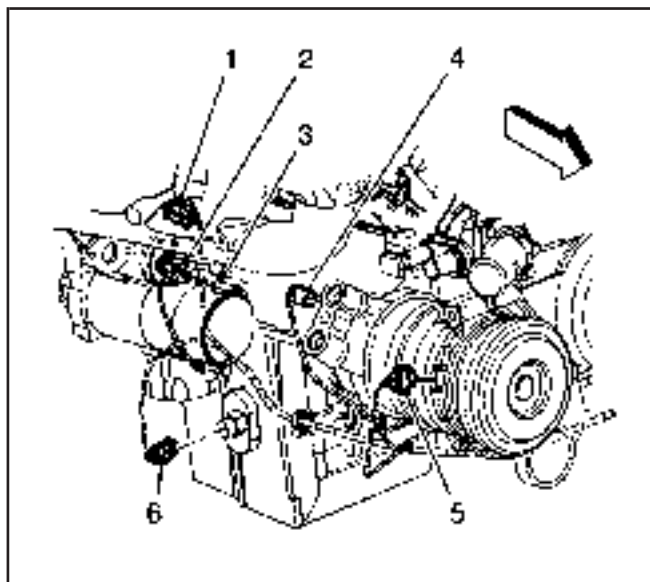
684224

Engine Oil Level Sensor and/or Switch Replacement

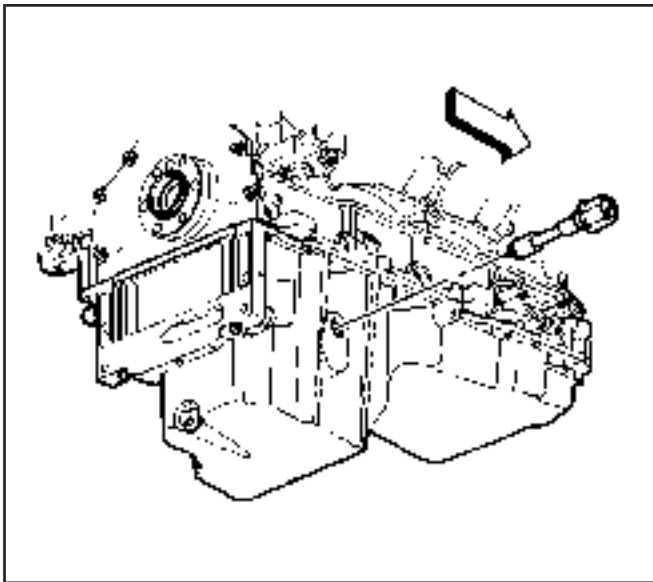
SIE-ID = 763186 LMD = 28-may-2002

Removal Procedure

1. Drain the engine oil. Refer to *Engine Oil and Oil Filter Replacement*.
2. Disconnect the oil level sensor electrical connector (6).

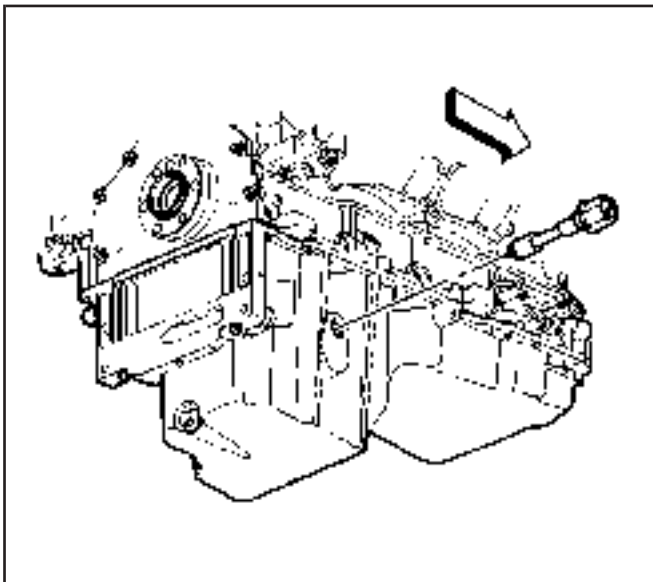


662991



260123

3. Remove the oil level sensor from the oil pan.



260123

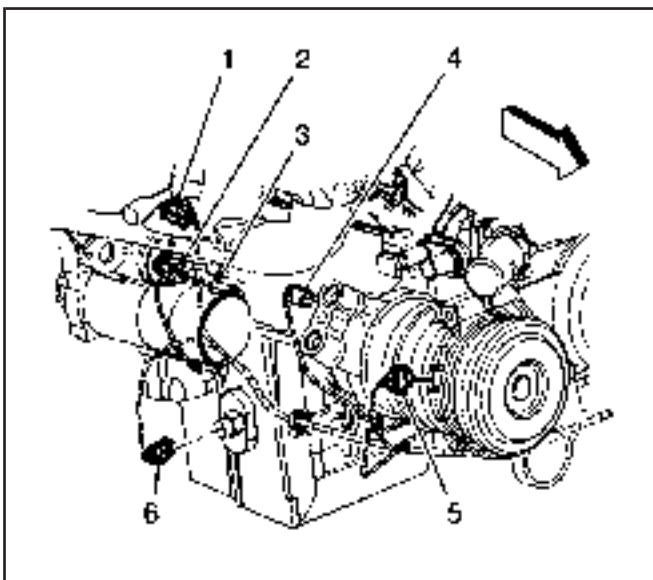
Installation Procedure

Notice: Refer to *Fastener Notice* in Cautions and Notices.

1. Install the oil level sensor to the oil pan.

Tighten

Tighten the sensor to 13 N·m (115 lb in).



662991

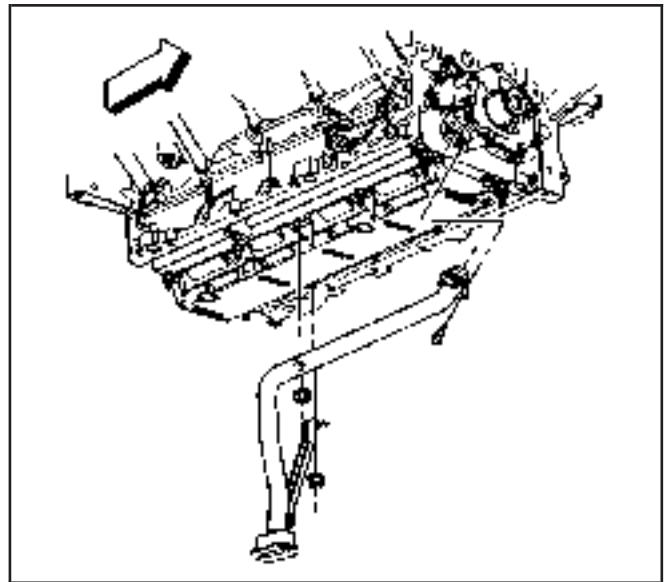
2. Connect the oil level sensor electrical connector (6).
3. Fill the engine oil. Refer to *Engine Oil and Oil Filter Replacement*.

Oil Pump, Pump Screen and Deflector Replacement

SIE-ID = 824748 LMD = 28-jan-2002

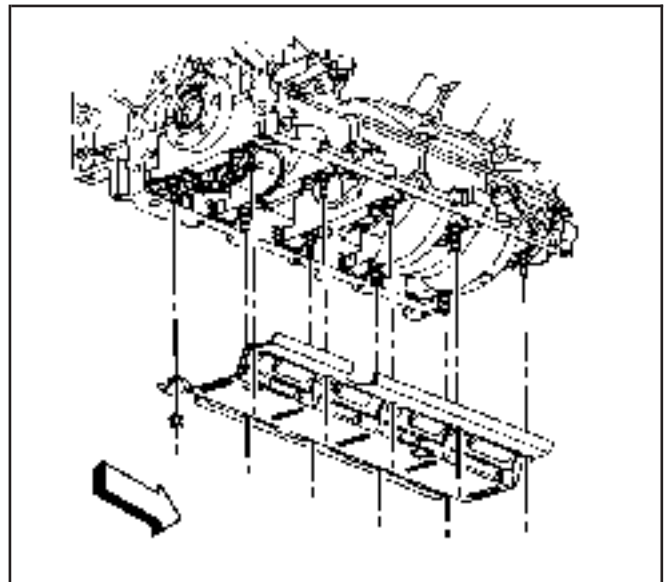
Removal Procedure

1. Remove the oil pan. Refer to *Oil Pan Replacement*.
2. Remove the engine front cover. Refer to *Engine Front Cover Replacement*.
3. Remove the oil pump screen bolt and nuts.
4. Remove the oil pump screen with O-ring seal.
5. Remove the O-ring seal from the pump screen.
6. Discard the O-ring seal.



647800

7. Remove the remaining crankshaft oil deflector nuts.
8. Remove the crankshaft oil deflector.

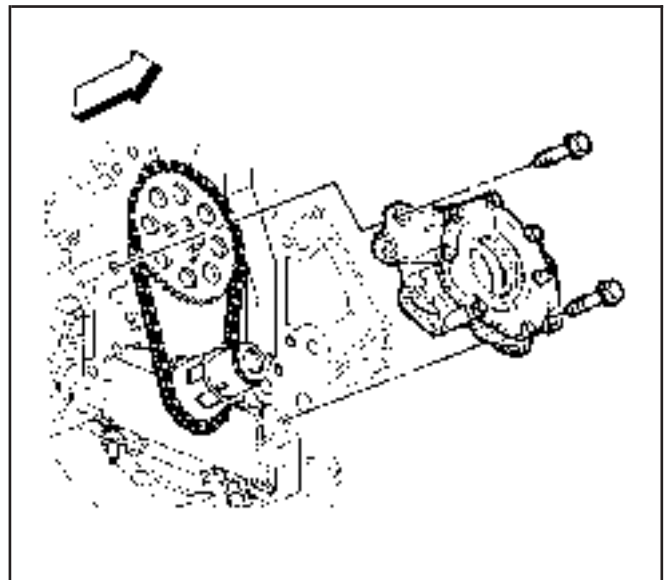


683798

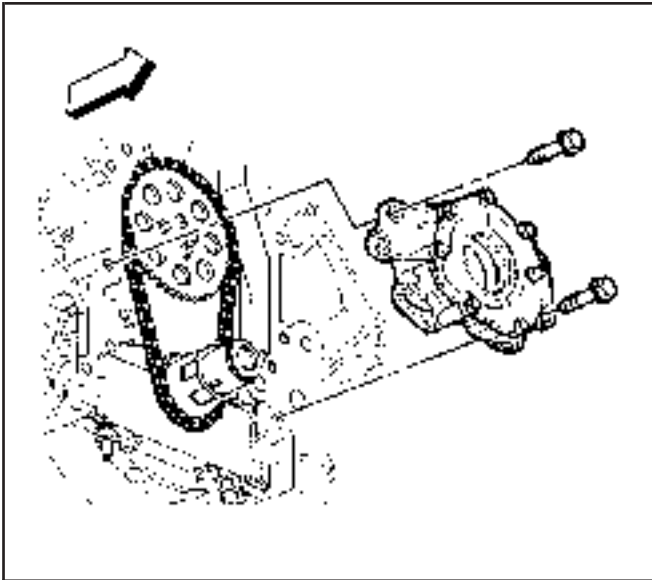
9. Remove the oil pump bolts.

Important: Do not allow dirt or debris to enter the oil pump assembly, cap end as necessary.

10. Remove the oil pump.
11. If required, clean and inspect the oil pump. Refer to *Oil Pump Cleaning and Inspection*.



64281



64281

Installation Procedure

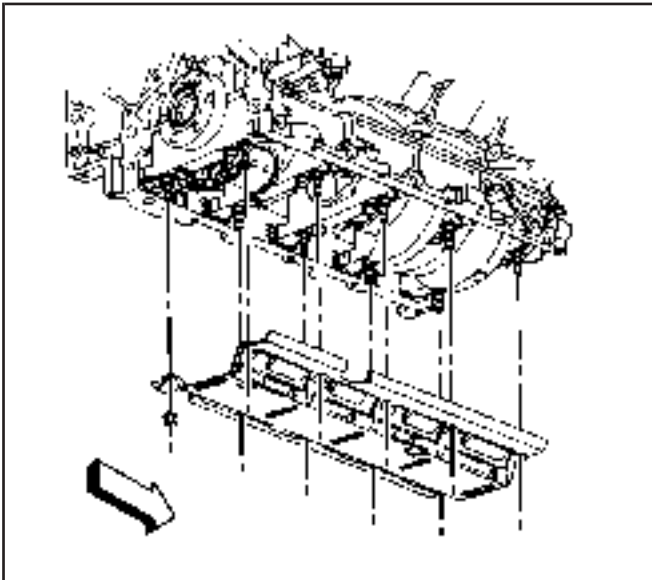
1. Align the splined surfaces of the crankshaft sprocket and the oil pump drive gear and install the oil pump.
2. Install the oil pump onto the crankshaft sprocket until the pump housing contacts the face of the engine block.

Notice: Refer to *Fastener Notice* in Cautions and Notices.

3. Install the oil pump bolts.

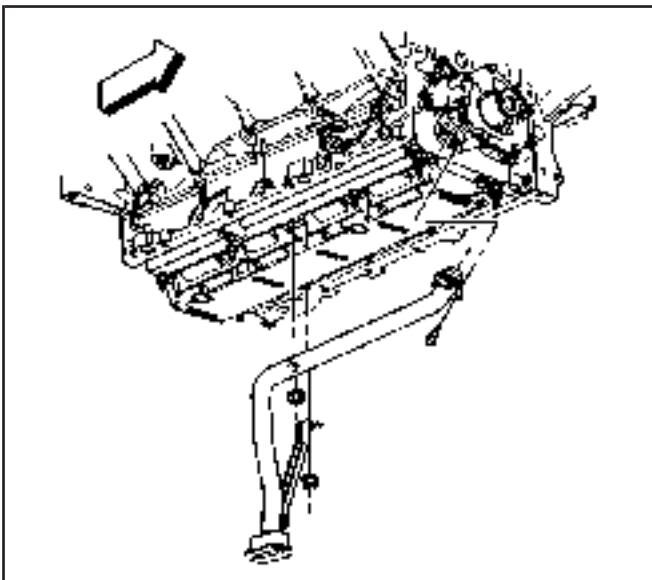
Tighten

Tighten the bolts to 25 N·m (18 lb ft).



683798

4. Install the crankshaft oil deflector and nuts until snug.



647800

5. Lubricate a NEW oil pump screen O-ring seal with clean engine oil.
6. Install the NEW O-ring seal onto the oil pump screen.

Important: Push the oil pump screen tube completely into the oil pump prior to tightening the bolt. Do not allow the bolt to pull the tube into the pump.

7. Align the oil pump screen mounting brackets with the correct crankshaft bearing cap studs.
8. Install the oil pump screen.
9. Install the oil pump screen bolt and nuts.

Tighten

9.1. Tighten the bolt to 12 N·m (106 lb in).

9.2. Tighten the nuts to 25 N·m (18 lb ft).

10. Install the engine front cover. Refer to *Engine Front Cover Replacement*.

11. Install the oil pan. Refer to *Oil Pan Replacement*.

Timing Chain and Sprockets Replacement

SIE-ID = 824749 LMD = 28-may-2002

Tools Required

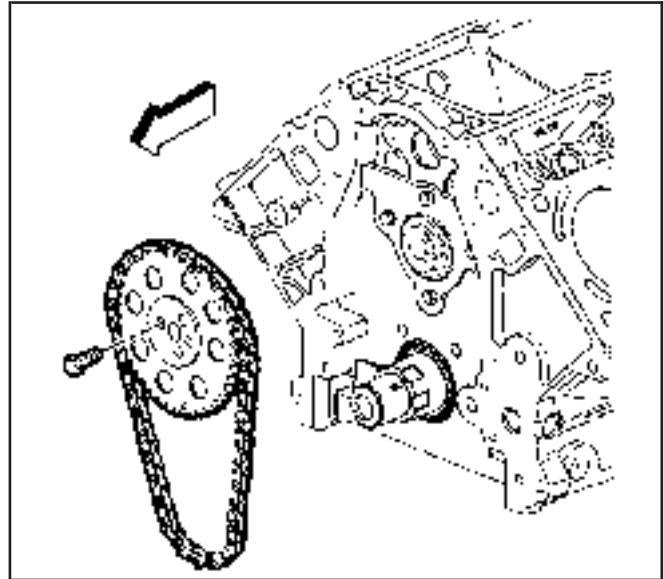
- J 8433 Two Jaw Puller
- J 41816-2 Crankshaft End Protector
- J 41558 Crankshaft Sprocket Remover
- J 41665 Crankshaft Balancer and Sprocket Installer

Removal Procedure

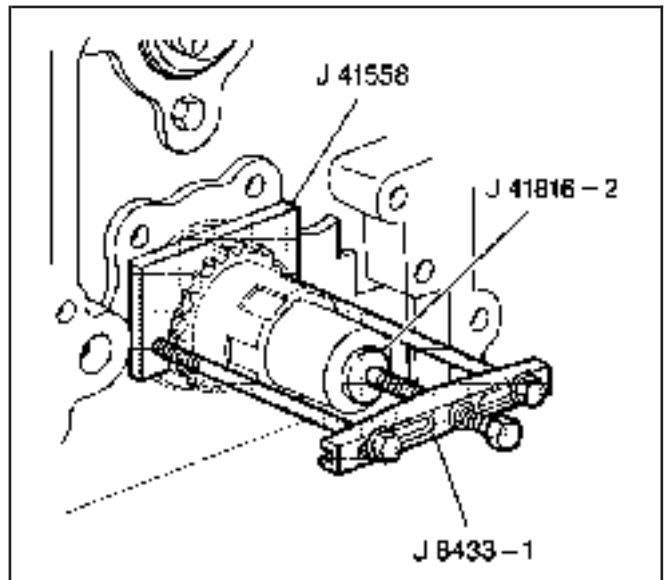
1. Remove the oil pump. Refer to *Oil Pump, Pump Screen and Deflector Replacement*.
2. Rotate the crankshaft until the timing marks on the crankshaft and the camshaft sprockets are aligned.

Notice: SIO-ID = 14030 LMD = 12-oct-1995 Do not turn the crankshaft assembly after the timing chain has been removed in order to prevent damage to the piston assemblies or the valves.

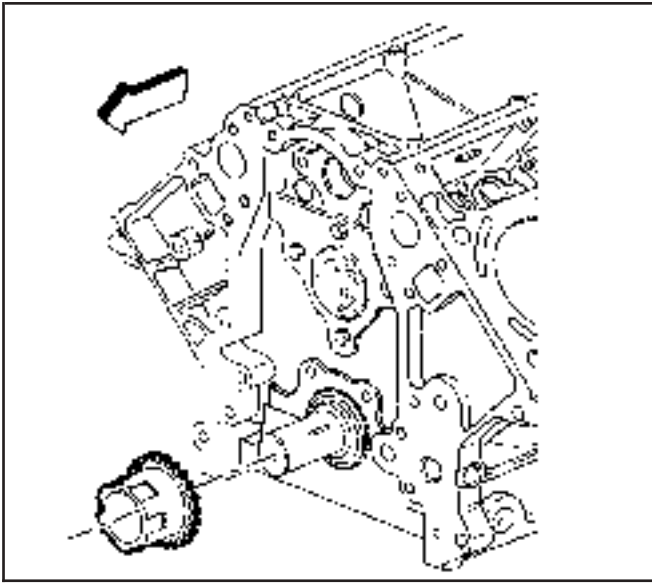
3. Remove the camshaft sprocket bolts.
4. Remove the camshaft sprocket and timing chain.
5. Use the J 8433, the J 41816-2 and the J 41558 in order to remove the crankshaft sprocket.



63263

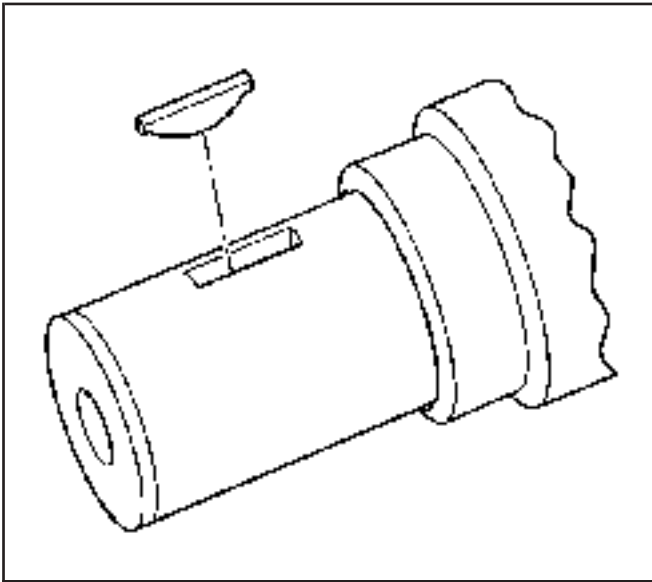


63189



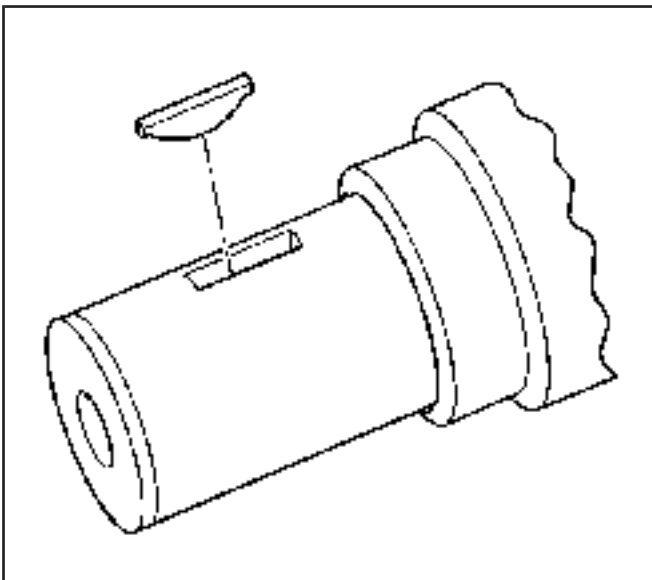
156150

6. Remove the crankshaft sprocket.



156149

7. Remove the crankshaft sprocket key, if required.
8. If required, clean and inspect the timing chain and sprockets. Refer to *Timing Chain and Sprockets Cleaning and Inspection*.

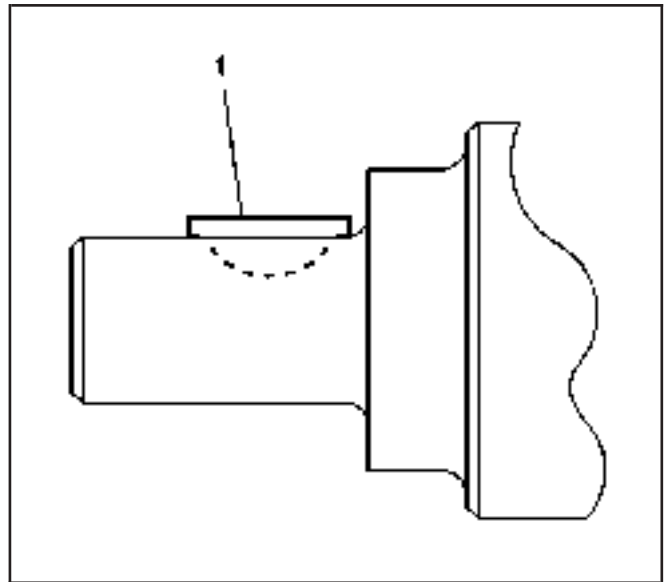


156149

Installation Procedure

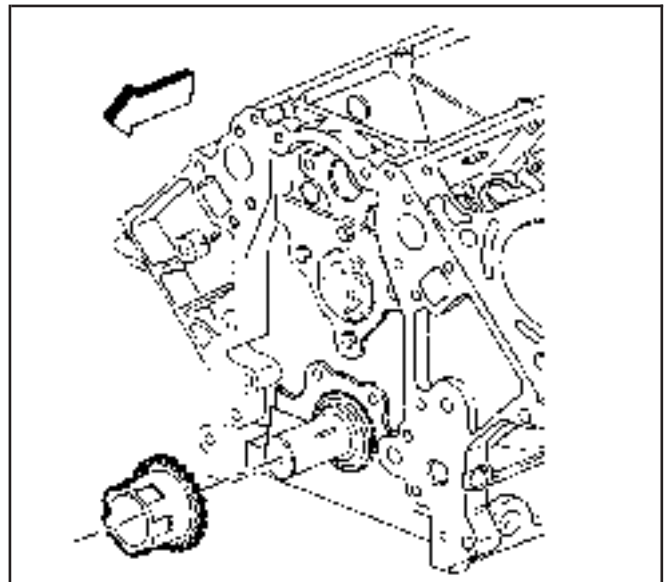
1. Install the key into the crankshaft keyway, if previously removed.

2. Tap the key (1) into the keyway until both ends of the key bottom onto the crankshaft.



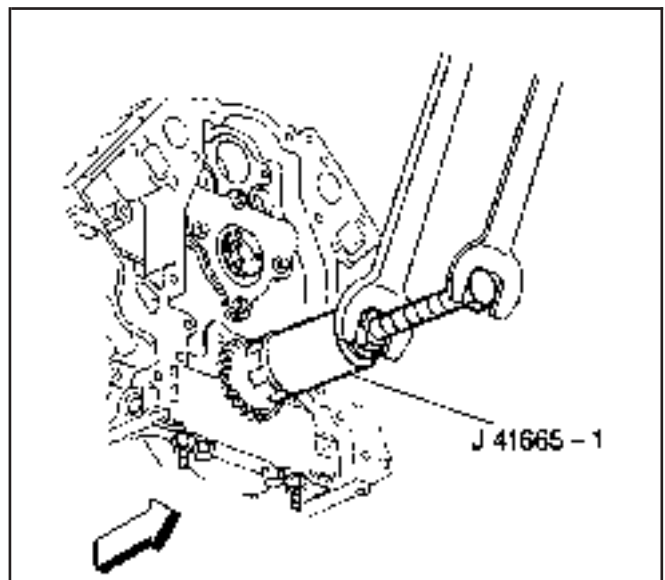
490871

3. Install the crankshaft sprocket onto the front of the crankshaft. Align the crankshaft key with the crankshaft sprocket keyway.

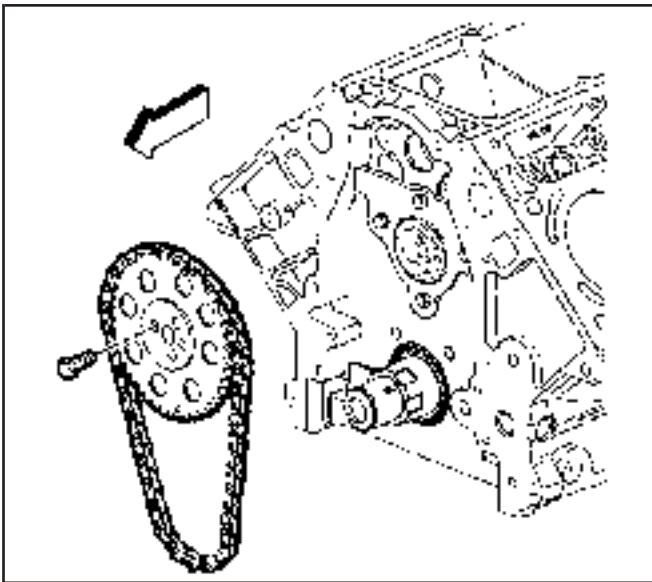


156150

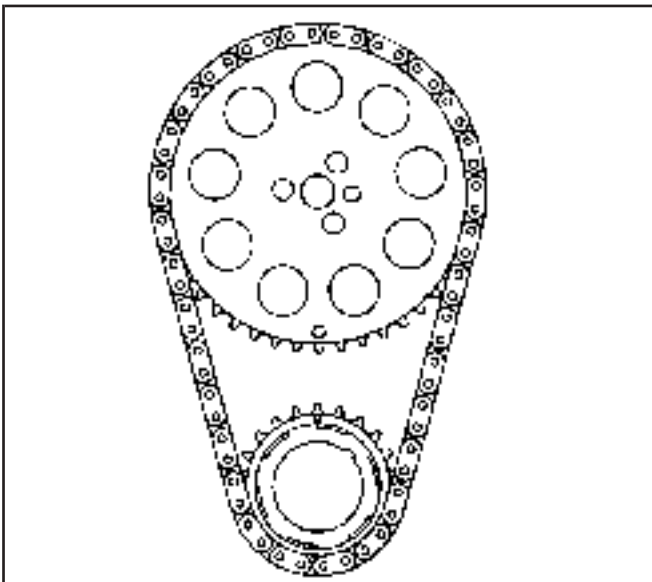
4. Use the *J 41665* in order to install the crankshaft sprocket.
Install the sprocket onto the crankshaft until fully seated against the crankshaft flange.
5. Rotate the crankshaft sprocket until the alignment mark is in the 12 o'clock position.



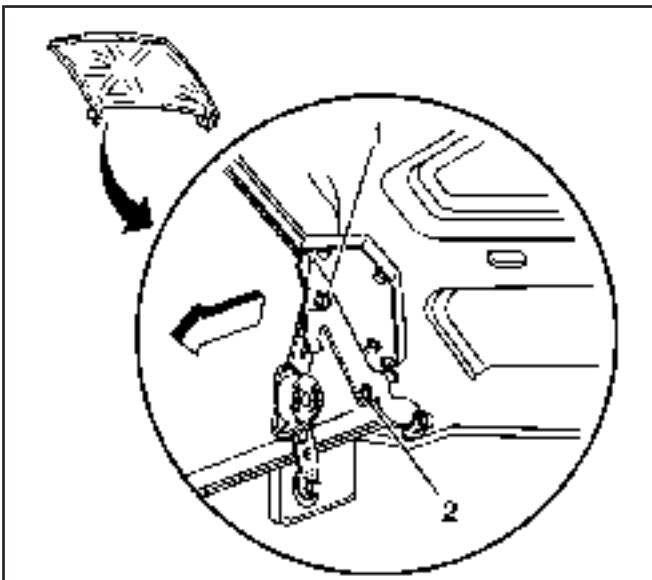
63199



63263



156158



310799

Important:

- Properly locate the camshaft sprocket locating pin with the camshaft sprocket alignment hole.
- The sprocket teeth and timing chain must mesh.
- The camshaft and the crankshaft sprocket alignment marks **MUST** be aligned properly.
Locate the camshaft sprocket alignment mark in the 6 o'clock position.

6. Install the camshaft sprocket and timing chain.

7. If necessary, rotate the camshaft or crankshaft sprockets in order to align the timing marks.

Notice: Refer to *Fastener Notice* in Cautions and Notices.

8. Install the camshaft sprocket bolts.

Tighten

Tighten the bolts to 35 N·m (26 lb ft).

9. Install the oil pump. Refer to *Oil Pump, Pump Screen and Deflector Replacement*.

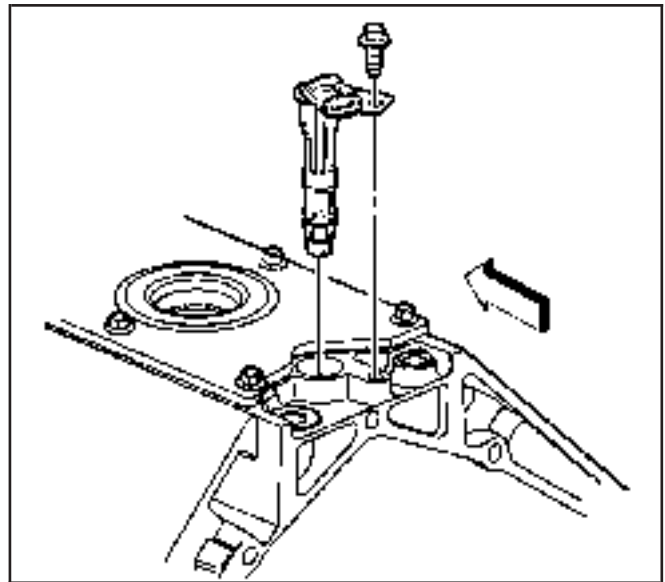
Camshaft Replacement

SIE-ID = 824751 LMD = 16-may-2002

Removal Procedure

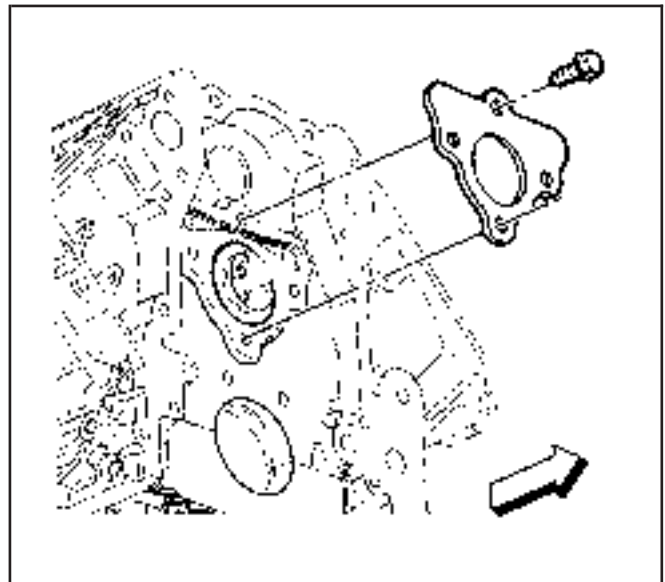
1. Raise the hood to the servicing position, perform the following:
 - Remove the hood hinge bolts (1).
 - Raise the hood until vertical.
 - Install the hood hinge bolts until snug in the service position (2).
2. Remove the radiator support. Refer to *Radiator Support Replacement* in Body Front End.
3. Remove the timing chain and camshaft sprocket. Refer to *Timing Chain and Sprockets Replacement*.
4. Remove the valve lifters from both cylinder heads. Refer to *Valve Lifter Replacement*.

5. Remove the camshaft sensor bolt and sensor.



260128

6. Remove the camshaft retainer bolts and retainer.



63211

Notice: SIO-ID = 13833 LMD = 03-feb-1998 All camshaft journals are the same diameter, so care must be used in removing or installing the camshaft to avoid damage to the camshaft bearings.

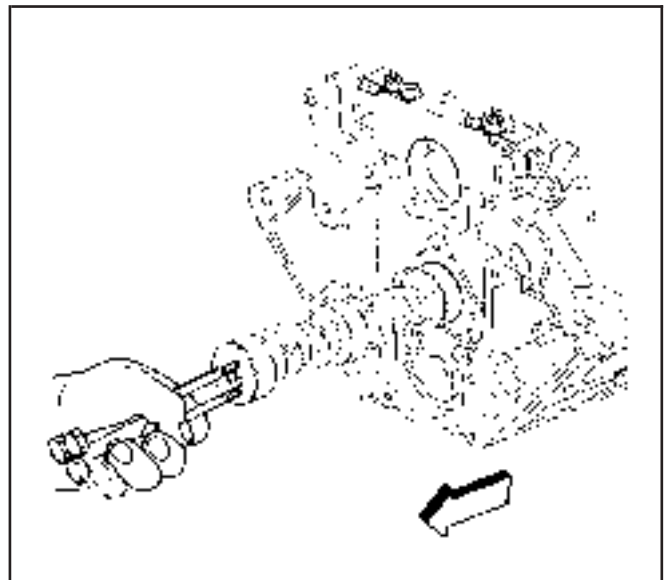
7. Remove the camshaft.

7.1. Install three M8-1.25 x 100 mm (M8-1.25 x 4.0 in) bolts to the bolt holes in the front of the camshaft.

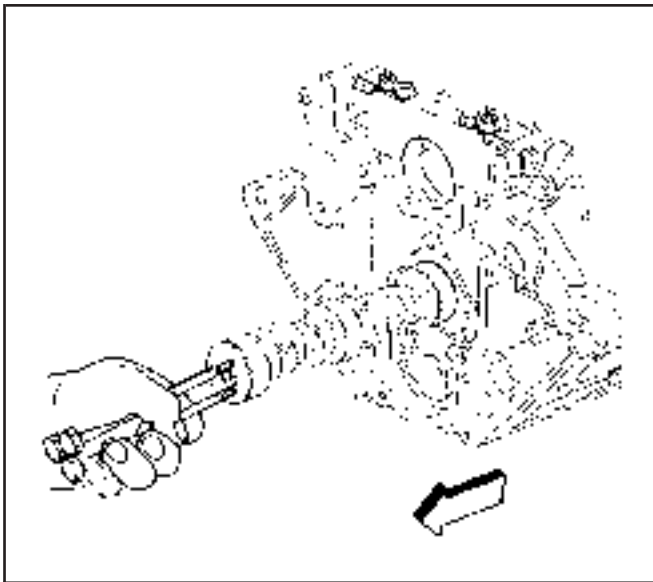
7.2. Using the bolts as a handle, carefully rotate and pull the camshaft out of the engine block.

7.3. Remove the three bolts from the camshaft.

8. If required, clean and inspect the camshaft and bearings. Refer to *Camshaft and Bearings Cleaning and Inspection*.



63212



63212

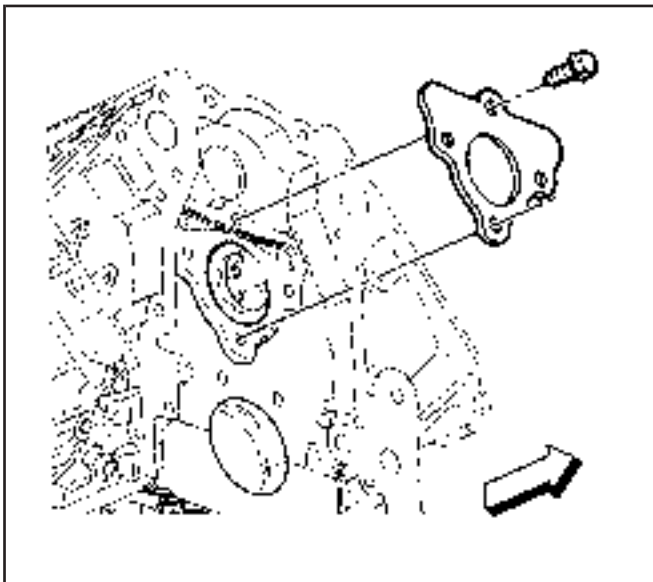
Installation Procedure

Important: If camshaft replacement is required, the valve lifters must also be replaced.

1. Lubricate the camshaft journals and the bearings with clean engine oil.
2. Install three M8-1.25 x 100 mm (M8-1.25 x 4.0 in) bolts to the bolt holes in the front of the camshaft.

Notice: SIO-ID = 13833 LMD = 03-feb-1998 All camshaft journals are the same diameter, so care must be used in removing or installing the camshaft to avoid damage to the camshaft bearings.

3. Using the bolts as a handle, carefully install the camshaft into the engine block.
4. Remove the three bolts from the front of the camshaft.



63211

Notice: Refer to *Fastener Notice* in Cautions and Notices.

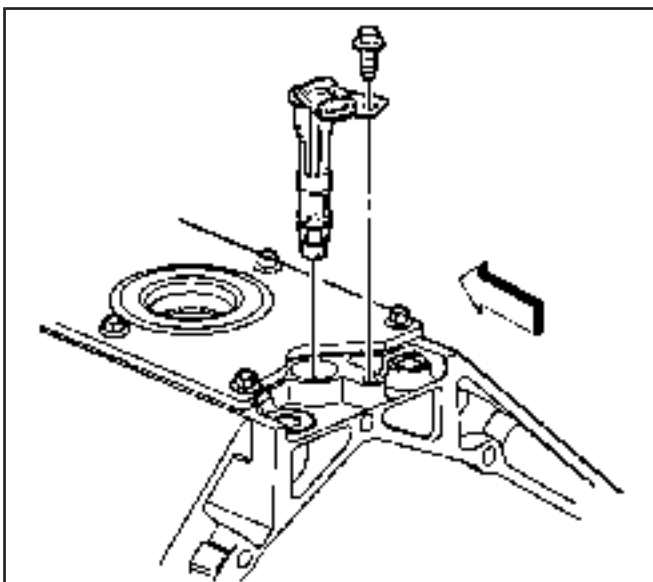
Important: Install the retainer plate with the sealing gasket facing the engine block.

The gasket surface on the engine block should be clean and free of dirt and/or debris.

5. Install the camshaft retainer and bolts.

Tighten

Tighten the bolts to 25 N·m (18 lb ft).



260128

6. Inspect the camshaft sensor O-ring seal. If the O-ring seal is not cut or damaged, it may be reused.
7. Lubricate the O-ring seal with clean engine oil.
8. Install the camshaft sensor and bolt.

Tighten

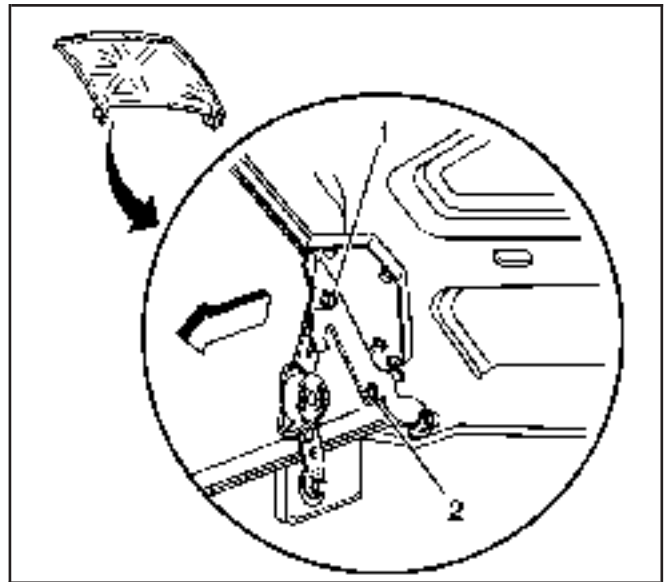
Tighten the bolt to 25 N·m (18 lb ft).

9. Install the timing chain and camshaft sprocket. Refer to *Timing Chain and Sprockets Replacement*.
10. Install the valve lifters. Refer to *Valve Lifter Replacement*.
11. Install the radiator support. Refer to *Radiator Support Replacement* in Body Front End.

12. Remove the hood hinge bolts from the service position (2).
13. Lower the hood to the normal position.
14. Install the hood hinge bolts.

Tighten

Tighten the bolts to 25 N·m (18 lb ft).



310799

Engine Flywheel Replacement

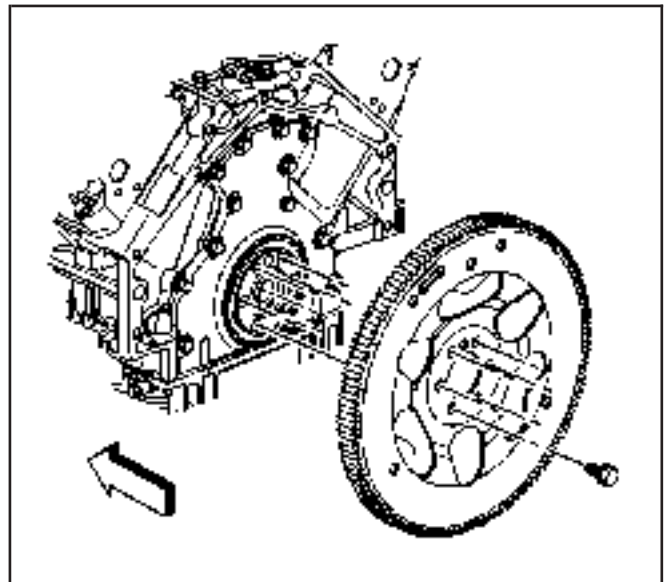
SIE-ID = 824809 LMD = 11-feb-2002

Removal Procedure

1. Remove the automatic transmission. Refer to *Transmission Replacement* in Automatic Transmission – 4L60-E or *Transmission Replacement* in Automatic Transmission – 4L80-E.

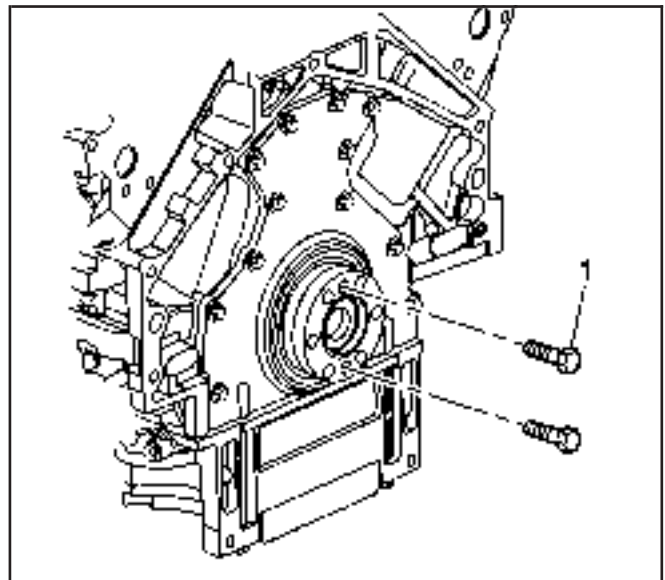
Important: Note the position and direction of the engine flywheel before removal.

2. Remove the flywheel bolts.
3. Remove the flywheel.

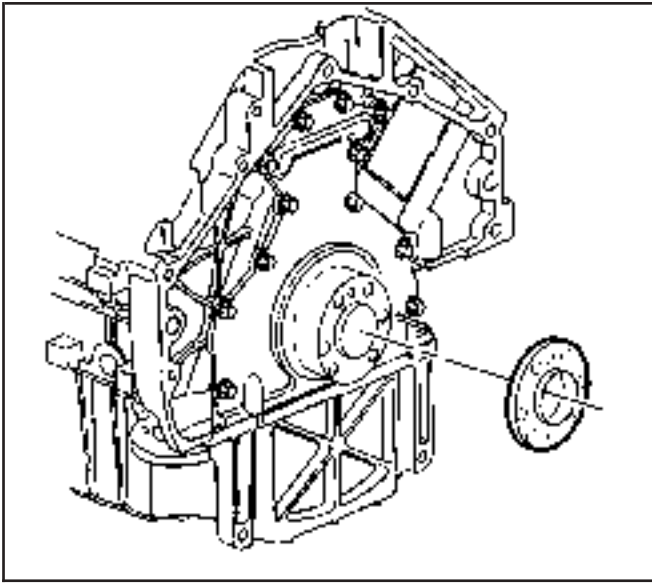


832979

4. Install two M11x1.5 mm bolts (1) to the threaded holes of the spacer, if applicable.
5. Rotate the bolts clockwise to remove the spacer.

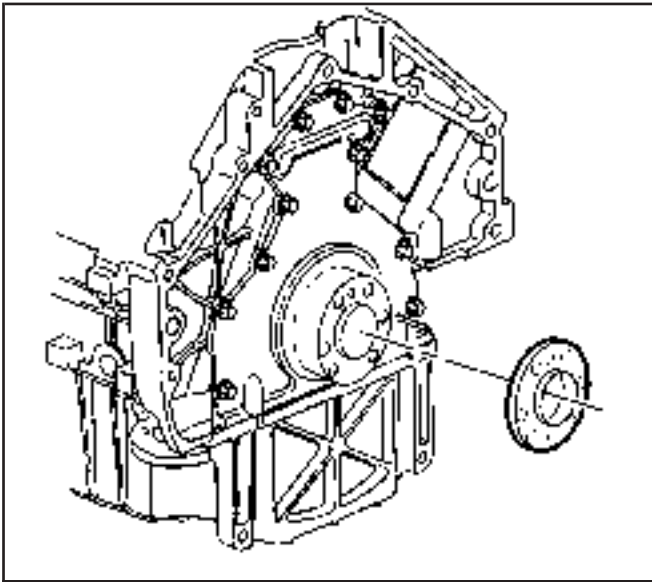


642281



642276

6. Remove the spacer from the rear of the crankshaft, if applicable.

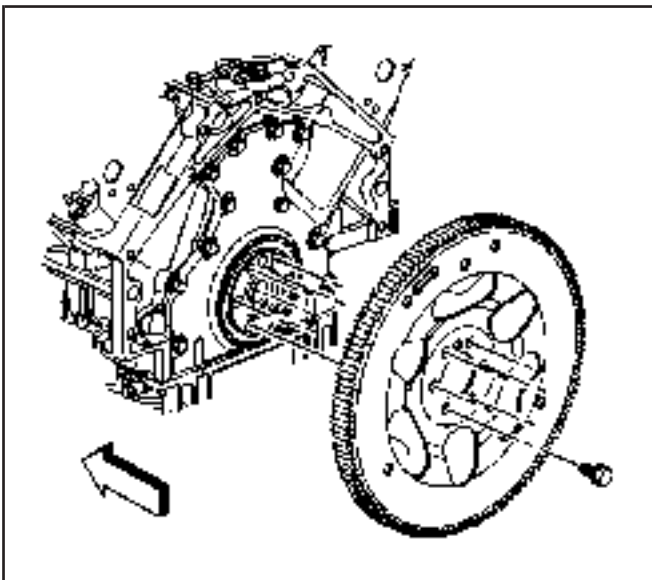


642276

Installation Procedure

Important:

- The flywheel does not use a locating pin for alignment and will not initially seat against the crankshaft flange or spacer, if applicable, but will be pulled onto the crankshaft by the engine flywheel bolts. This procedure requires a three stage tightening process.
 - Certain applications (6.0L) require a spacer and longer bolts for proper flywheel position.
1. Install the spacer, if applicable, onto the rear of the crankshaft.



832979

2. Install the flywheel and bolts to the crankshaft.

Important: Longer flywheel bolts must be used on applications using a flywheel spacer.

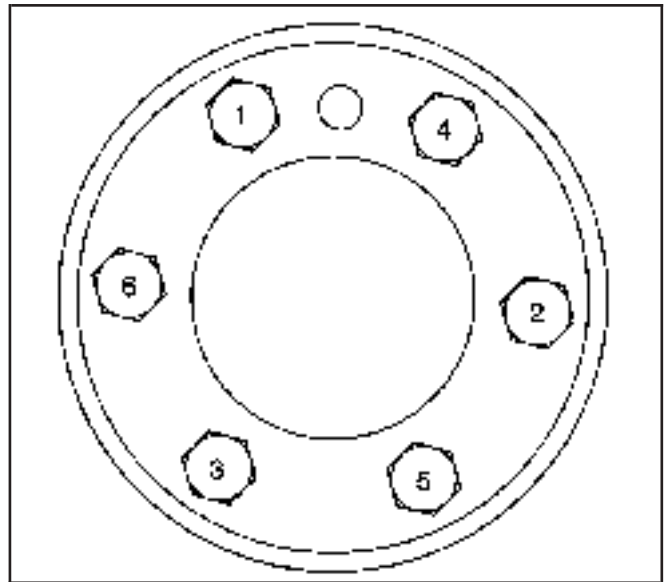
3. Apply threadlock GM P/N 12345382, (Canadian P/N 10953489) or equivalent to the threads of the flywheel bolts.

Notice: Refer to *Fastener Notice* in Cautions and Notices.

4. Tighten the flywheel bolts.

Tighten

- 4.1. Tighten the bolts a first pass in sequence to 20 N·m (15 lb ft).
 - 4.2. Tighten the bolts a second pass in sequence to 50 N·m (37 lb ft).
 - 4.3. Tighten the bolts a final pass in sequence to 100 N·m (74 lb ft).
5. Install the automatic transmission. Refer to *Transmission Replacement* in Automatic Transmission – 4L60-E or *Transmission Replacement* in Automatic Transmission – 4L80-E.



63174

Engine Replacement

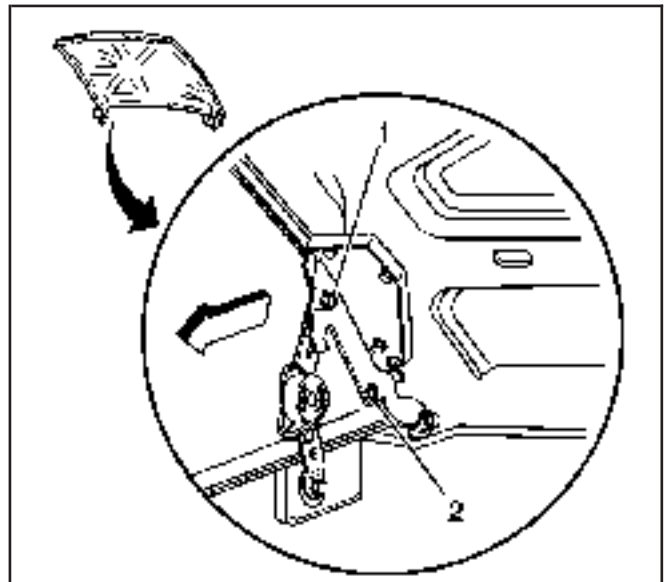
SIE-ID = 824754 LMD = 29-may-2002

Tools Required

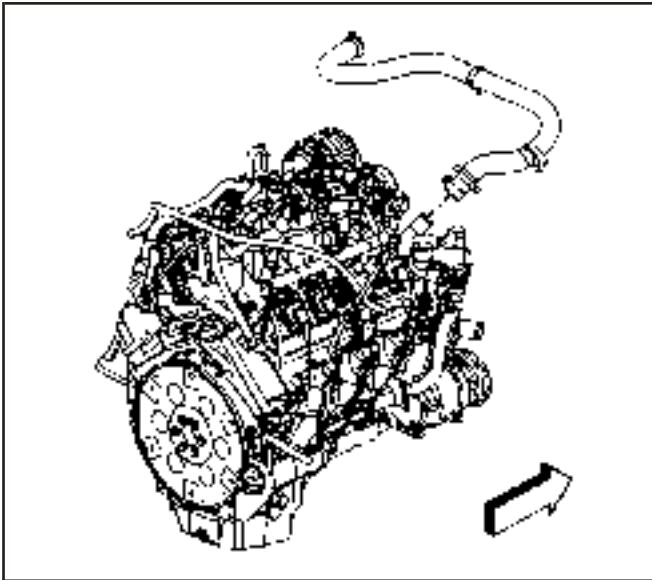
- J 41798 Engine Lifting Brackets
- J 21366 Converter Holding Strap

Removal Procedure

1. Open the hood.
2. Place fender covers over both fenders.
3. Raise the hood to the service position, perform the following:
 - 3.1. Remove the hood hinge bolts (1).
 - 3.2. Raise the hood until vertical.
 - 3.3. Install the hood hinge bolts until snug in the service position (2).
4. Remove the air conditioning (AC) compressor. Refer to *Compressor Replacement* in HVAC Systems - Manual.
5. Remove the radiator supports. Refer to *Radiator Support Replacement* in Body Front End.

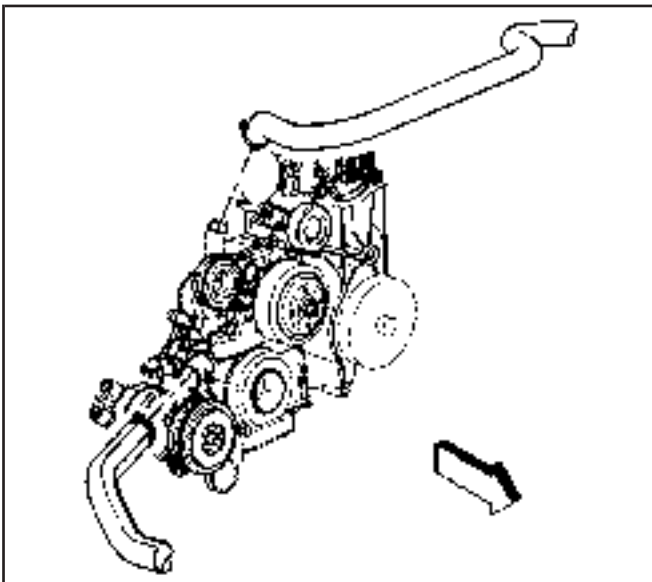


310799



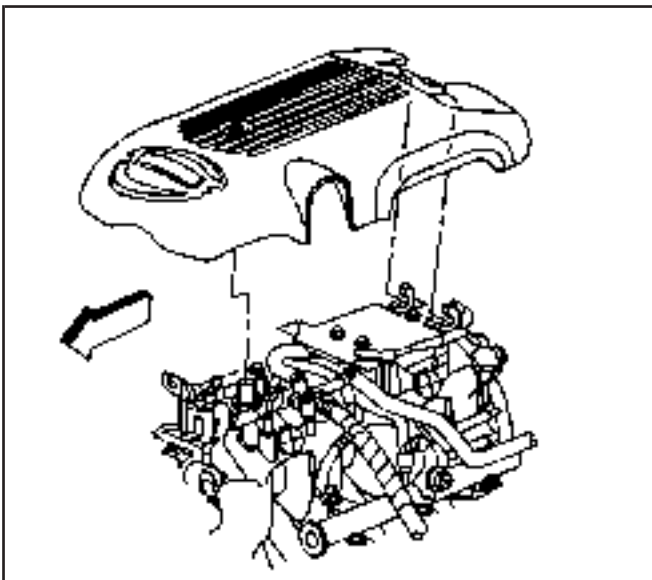
659418

6. Reposition the radiator inlet hose clamp at the water pump.
7. Remove the radiator inlet hose from the water pump.



308983

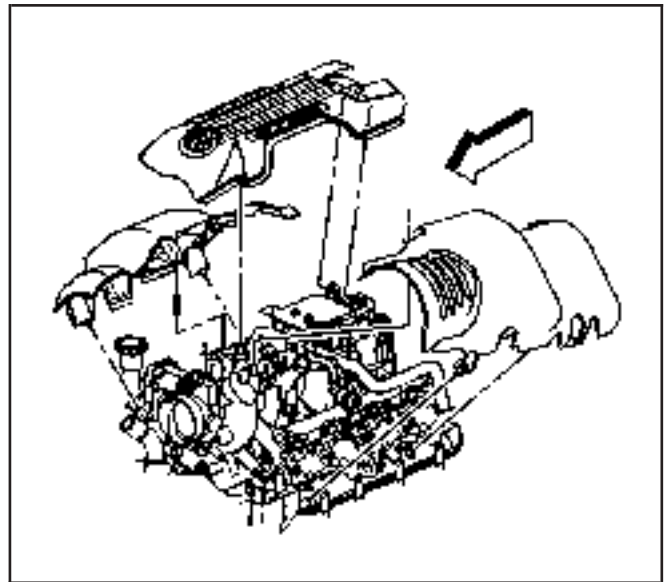
8. Reposition the radiator outlet hose clamp at the water pump.
9. Remove the radiator outlet hose from the water pump.
10. Remove the heater hoses. Refer to *Heater Hose Replacement - Inlet (L18)* or *Heater Hose Replacement - Inlet (LR4, LM7, LQ4)* and *Heater Hose Replacement - Outlet (L18)* or *Heater Hose Replacement - Outlet (LR4, LM7, LQ4)* in Heating, Ventilation, and Air Conditioning.



832094

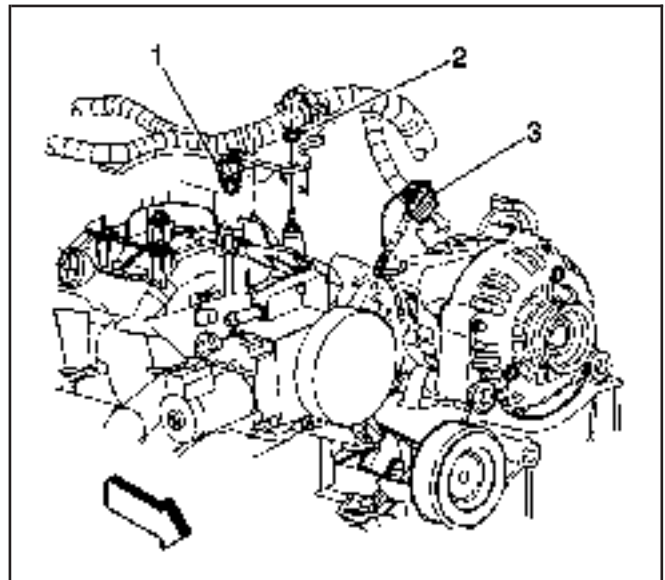
11. If equipped with the 4.8L, 5.3L, or 6.0L regular production option (RPO) LQ4, loosen the intake manifold sight shield bolt.
12. Remove the sight shield from the retainer.

13. If equipped with the 6.0L with RPO LQ9, perform the following:
14. Loosen the intake manifold sight shield bolt.
15. Loosen the left fuel rail cover bolts.
16. Remove the left fuel rail cover.
17. Loosen the right fuel rail cover bolts.
18. Remove the right fuel rail cover.
19. Remove the sight shield from the retainer.



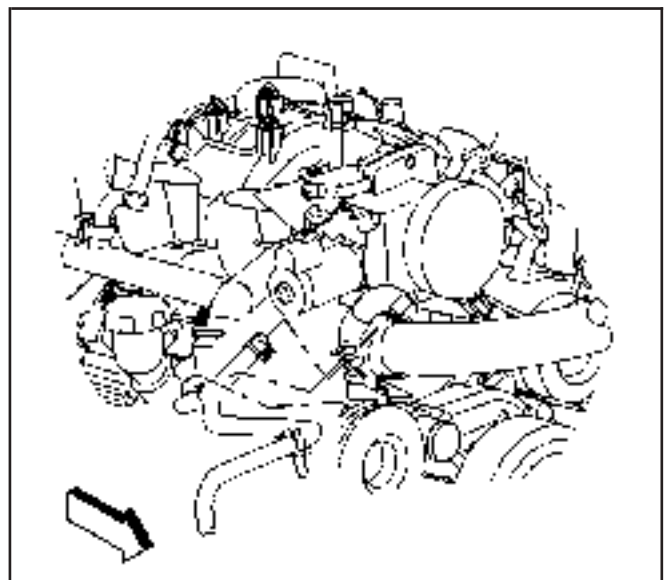
832097

20. Disconnect the following electrical connectors:
 - Evaporative emissions (EVAP) canister purge solenoid (1)
 - Generator (3)
 - Electronic throttle control (ETC)
21. Remove the harness bracket nut (2) in order to remove the engine harness from the intake manifold.

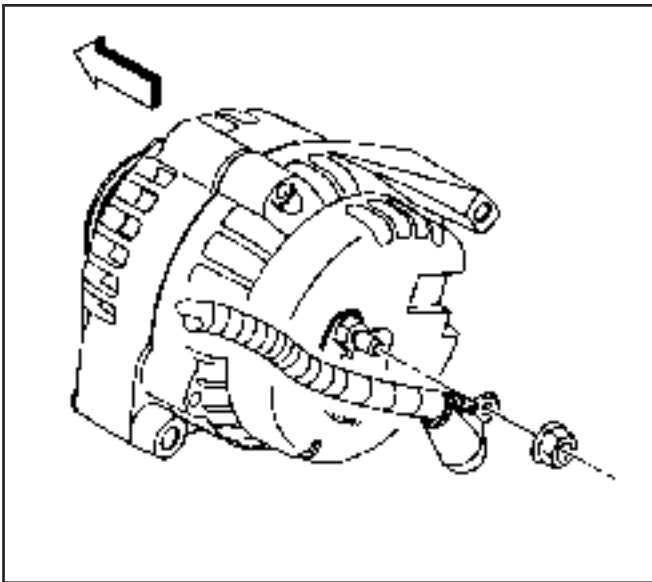


663672

22. Reposition the vent inlet hose clamp at the throttle body.
23. Remove the radiator vent inlet hose from the throttle body.

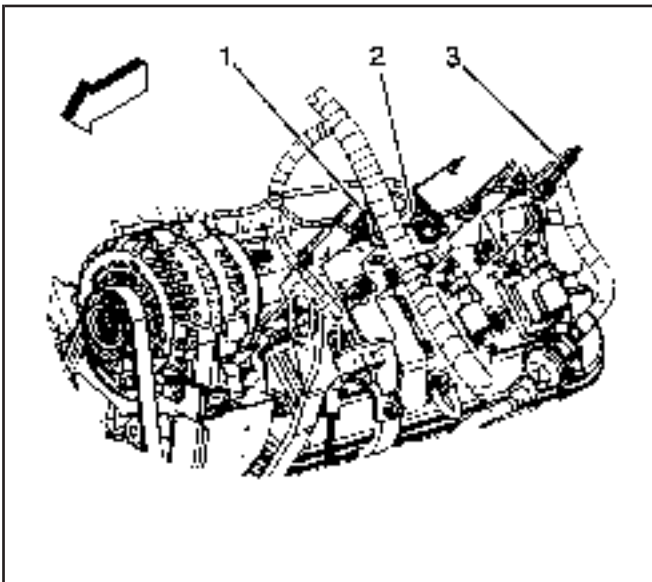


659465



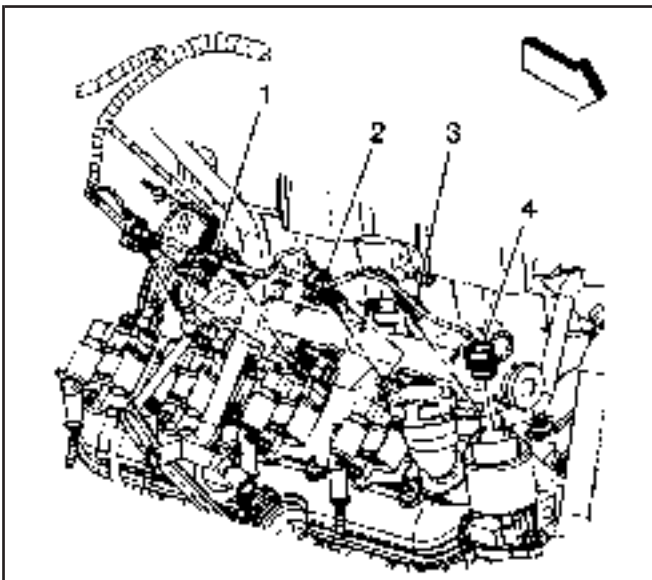
395686

24. Remove the generator cable from the generator, perform the following:
- 24.1. Slide the boot down revealing the terminal stud.
 - 24.2. Remove the generator cable nut from the terminal stud.
 - 24.3. Remove the generator cable.



679597

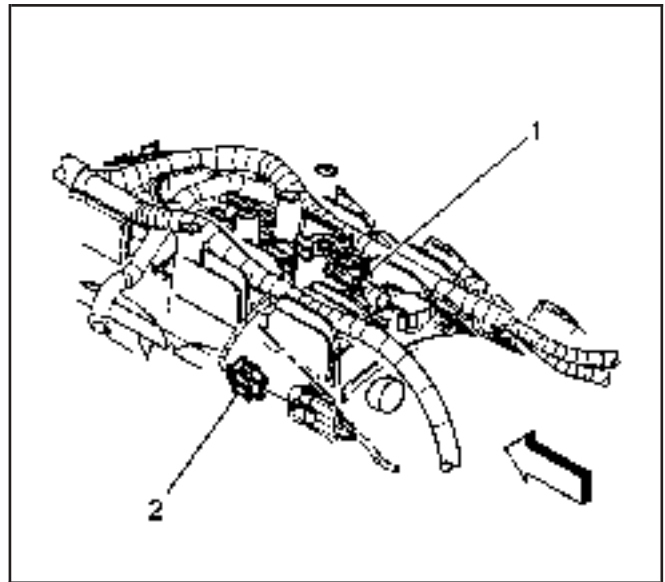
25. Disconnect the main coil harness (2) and fuel injector (3) electrical connectors on the left side.



679598

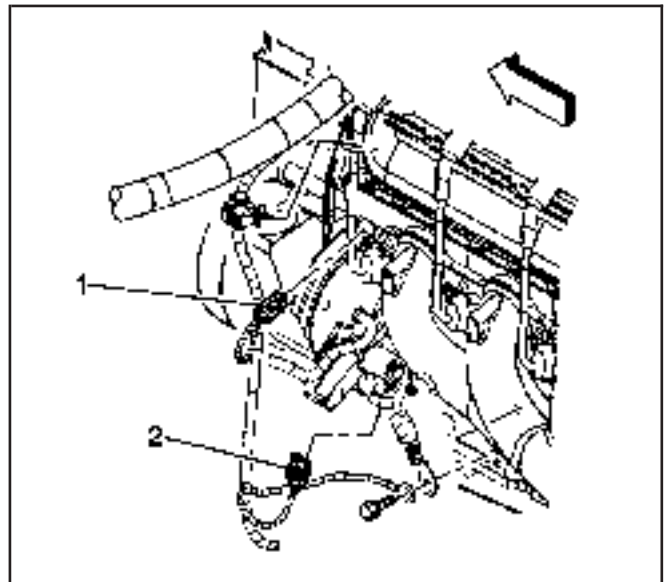
26. Disconnect the following electrical connectors:
- The main coil harness (1)
 - The fuel injectors (3)

27. Disconnect the manifold absolute pressure (MAP) sensor (1) and knock sensor (2) electrical connectors.



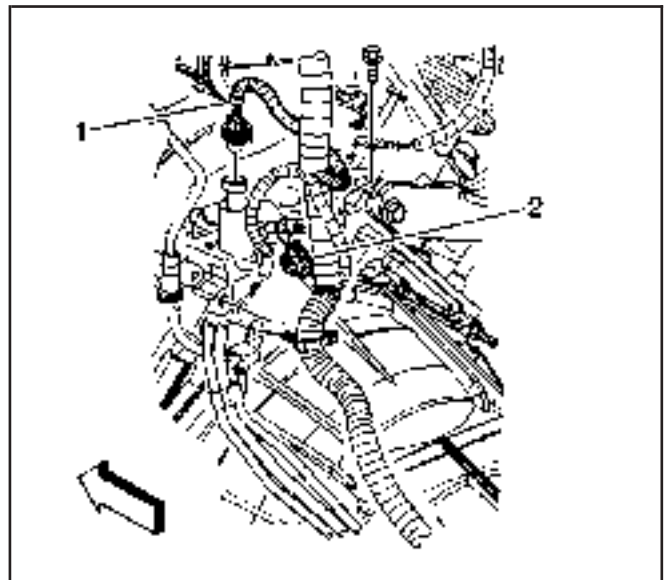
679510

28. Remove the harness ground bolt.
29. Reposition the harness ground and negative battery cable from the block.
30. Disconnect the following electrical connectors:
 - The coolant temperature sensor (1)
 - The electronic variable orifice switch (2)

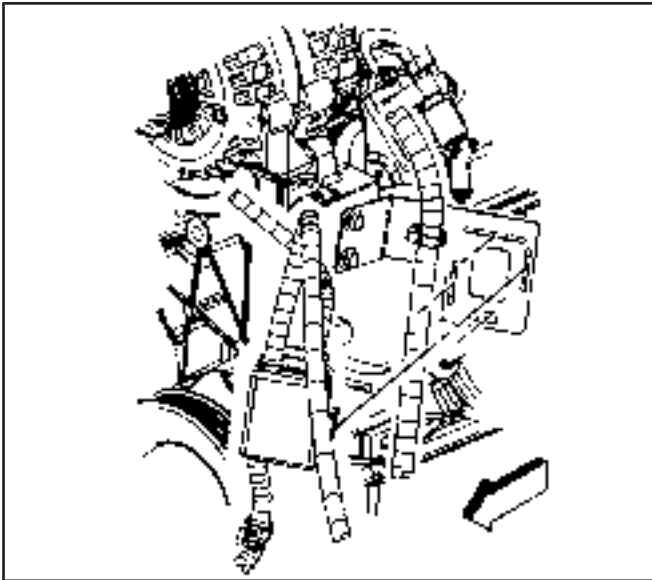


684221

31. Remove the harness ground bolt at the right rear of the engine block.
32. Reposition the harness ground, and auxiliary negative battery cable, if equipped from the block.
33. Remove the harness ground bolt at the left rear of the engine block
34. Reposition the harness ground, and engine ground strap from the block.
35. Disconnect the following electrical connectors:
 - The oil pressure sensor (1)
 - The camshaft position (CMP) sensor (2)
36. Unclip all of the engine harness clips from the engine.

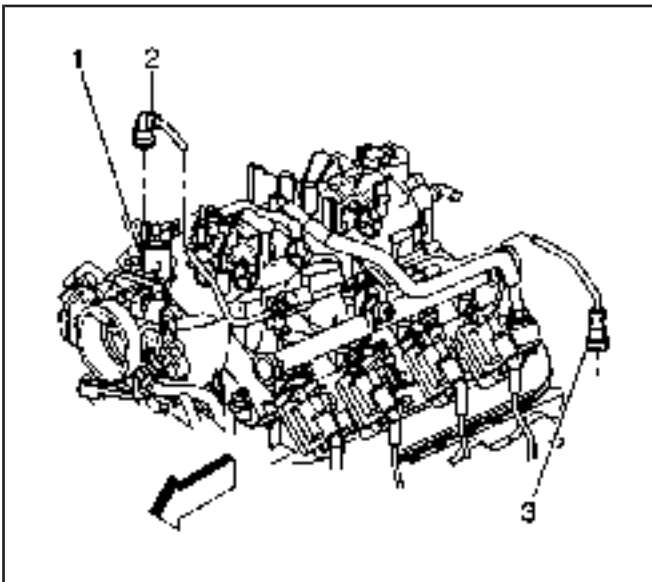


684224



662505

37. Remove the battery cable junction block from the junction block bracket.



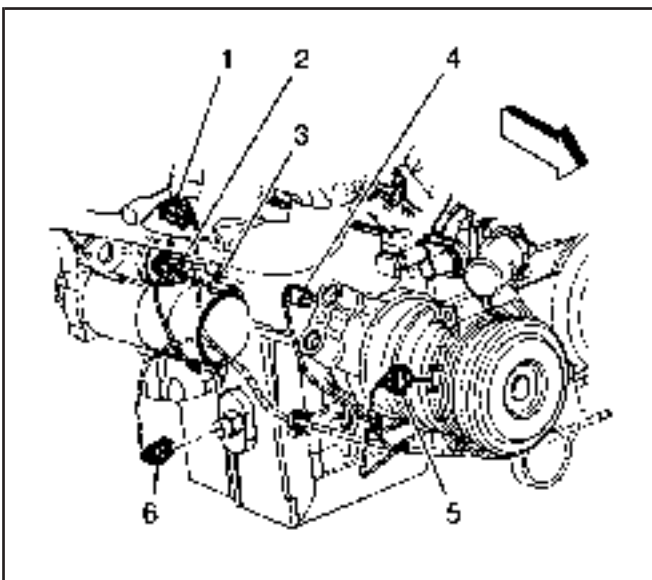
372717

38. Remove the EVAP purge solenoid vent tube, perform the following:

- Remove the EVAP tube end (2) from the solenoid (1).
- Remove the EVAP tube end (3) from the vapor pipe.

39. Disconnect the fuel pipes. Refer to *Quick Connect Fitting(s) Service (Metal Collar)* in Engine Controls – 4.8L, 5.3L, and 6.0L.

40. Raise the vehicle.

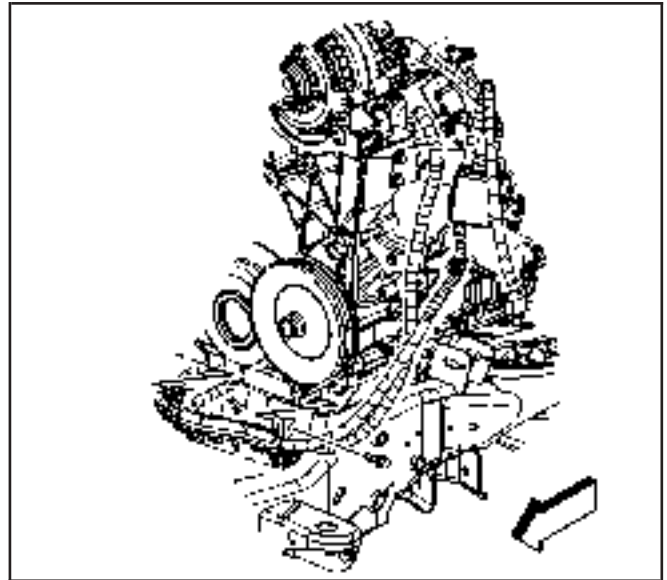


662991

41. Disconnect the following electrical connectors:

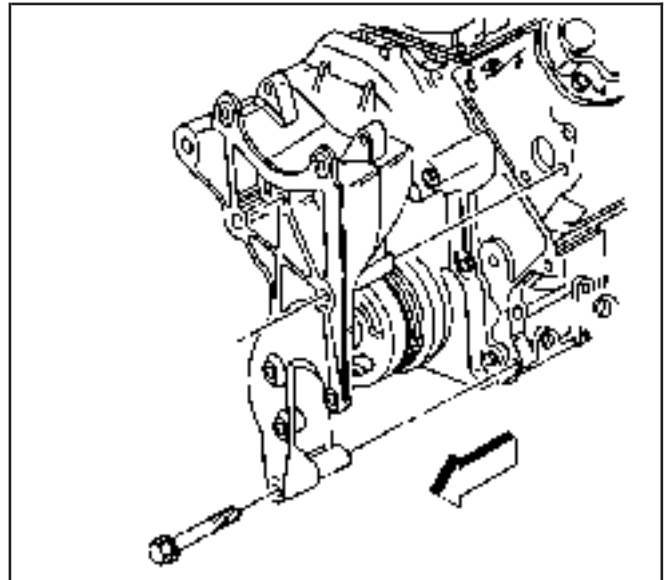
- The crankshaft position (CKP) sensor (1)
- The engine oil level sensor (6)
- The coolant heater, if equipped

42. Remove the battery cable channel bolt.
43. Slide the channel pin out of the oil pan tab.
44. Gather all branches of the engine wiring harness and reposition off to the side.
45. Lower the vehicle.



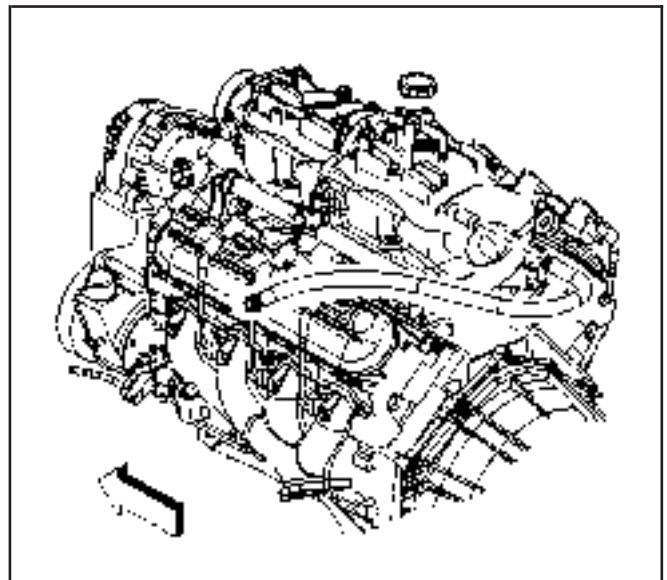
662508

46. Remove the rear power steering pump-to-engine block bolt.
47. Remove the generator bracket mounting bolts.
48. Position the bracket aside.

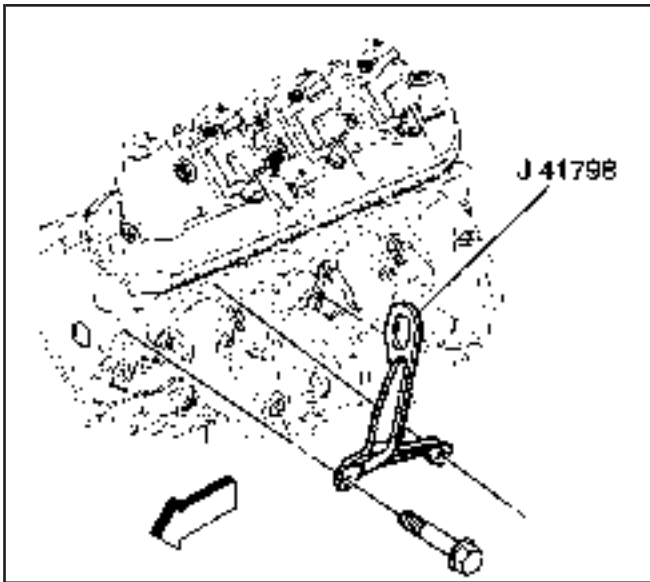


310813

49. Remove the vacuum brake booster hose.
50. Remove the ignition coil, as required for the proper fit of the *J 41798* before lifting the engine. Refer to *Ignition Coil(s) Replacement* in Engine Controls – 4.8L, 5.3L, and 6.0L.



382483



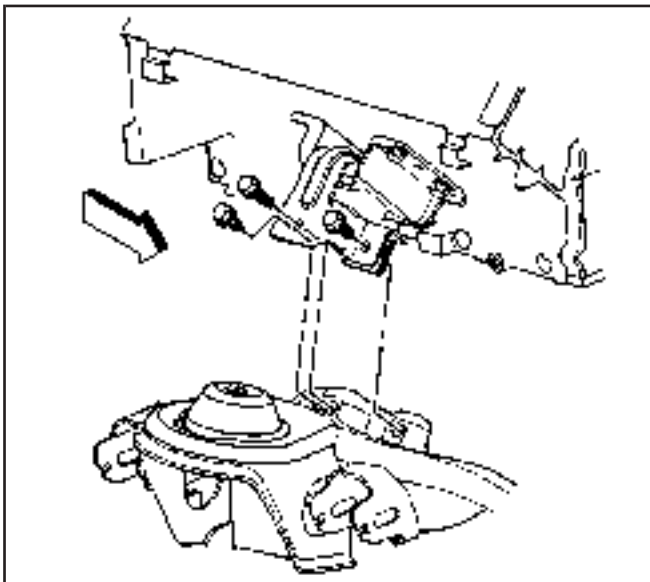
309151

Notice: Refer to *Fastener Notice* in Cautions and Notices.

51. Install the *J 41798* to the cylinder heads.

Tighten

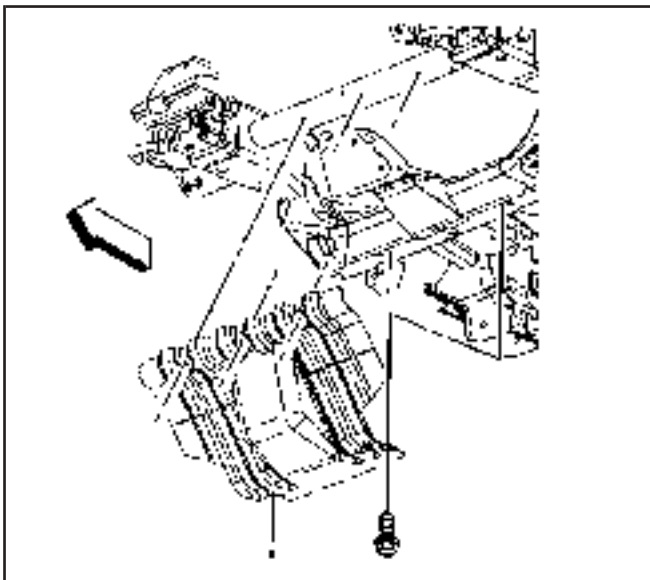
- Tighten the M8 engine lift bracket bolts to 25 N·m (18 lb ft).
- Tighten the M10 engine lift bracket bolts to 50 N·m (37 lb ft).



307275

52. Remove the left and right engine mount-to-engine mount bracket bolts.

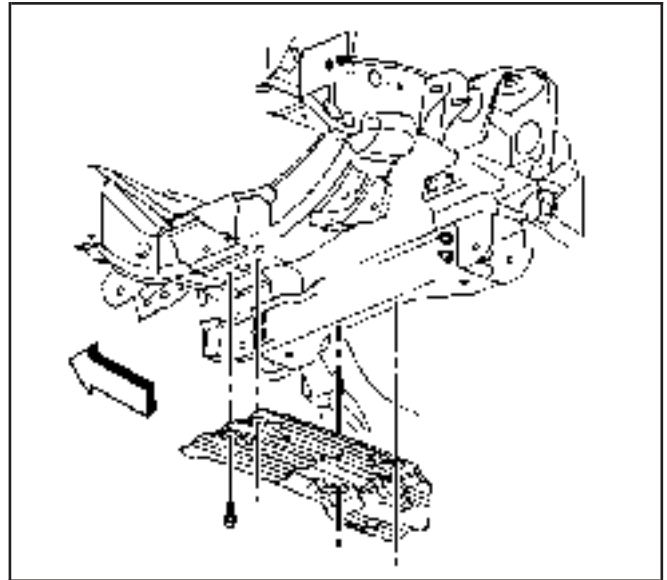
53. Raise and suitably support the vehicle. Refer to *Lifting and Jacking the Vehicle* in General Information.



349061

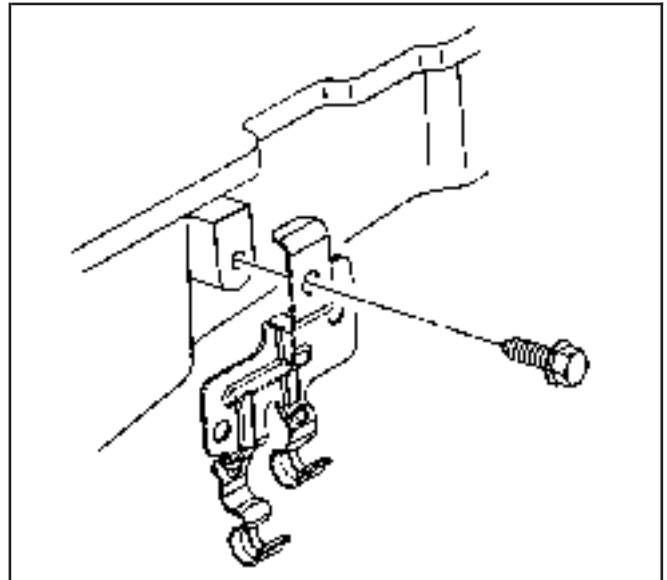
54. Remove the engine shield bolts and shield.

55. Remove the oil pan skid plate bolts and plate, if equipped.
56. Drain the engine oil.
57. Remove the starter motor. Refer to *Starter Motor Replacement (4.8L, 5.3L, and 6.0L Engines)* or *Starter Motor Replacement (8.1L Engine)* in Engine Electrical.
58. Remove the catalytic converter. Refer to *Catalytic Converter Replacement (4.8L and 5.3L Engines)* or *Catalytic Converter Replacement (6.0L and 8.1L Engines)* in Engine Exhaust.



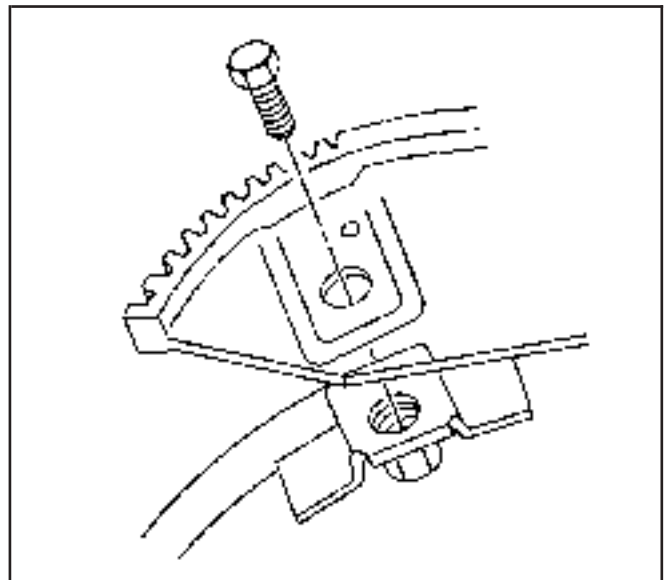
309158

59. Remove the positive battery cable clip bolt and clip.

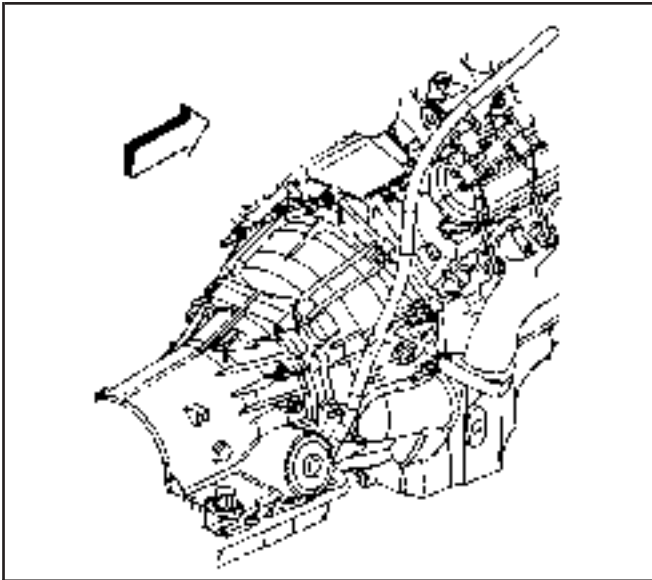


310672

60. Remove the flywheel to torque converter bolts.

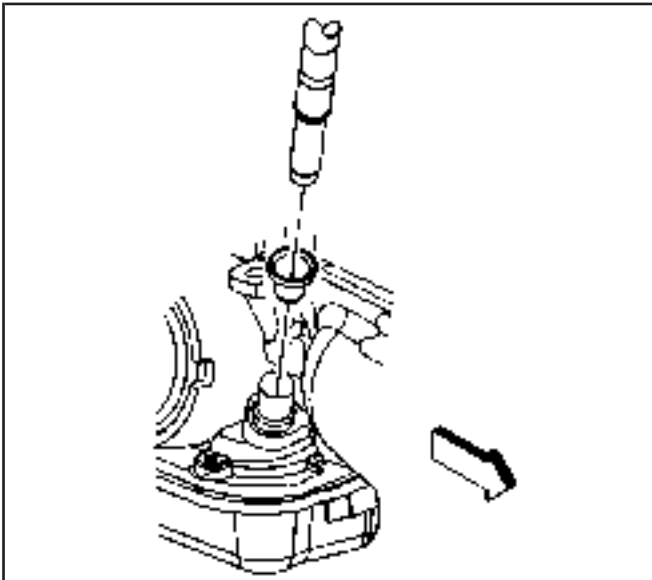


9096



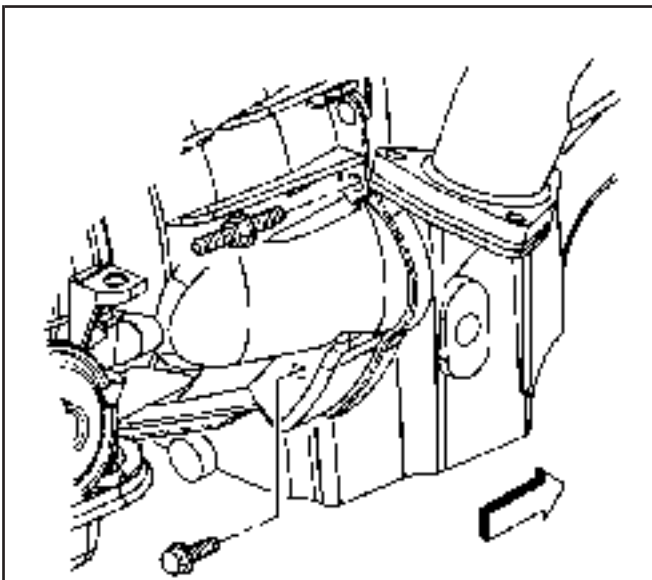
396797

61. Remove the transmission oil level indicator tube nut, if equipped.



396798

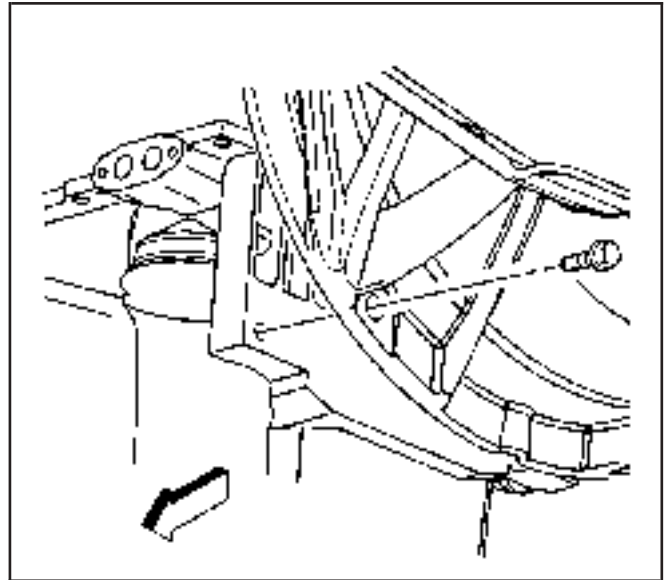
62. Remove the transmission oil level indicator tube, if equipped.



394448

63. If equipped with the 4L60-E automatic transmission, remove the transmission bolt and stud on the right side.

- 64. If equipped with the 4L80-E automatic transmission, remove the transmission converter cover bolts.



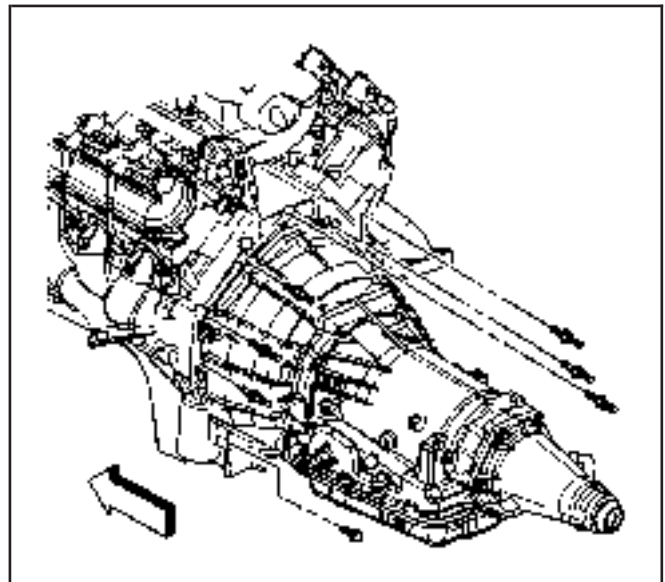
396795

- 65. Remove the automatic transmission bolt/studs, if equipped.
- 66. Separate the engine from the automatic transmission.
Install the *J 21366* to the transmission in order to hold the torque converter.
- 67. Lower the vehicle.
- 68. Install an engine hoist to the *J 41798*
- 69. Install a floor jack under the transmission for support.

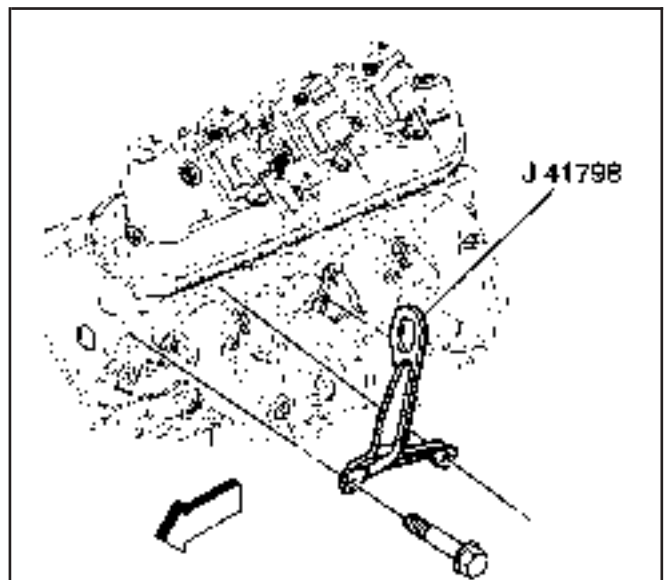
Notice: SIO-ID = 315360 LMD = 17-sep-1997 Use care while moving the engine assembly in order to avoid breaking the MAP sensor locating tabs. Broken MAP sensor tabs may result in decreased engine performance.

- 70. Remove the engine.
- 71. Install the engine to an engine stand.
- 72. Remove the engine hoist.

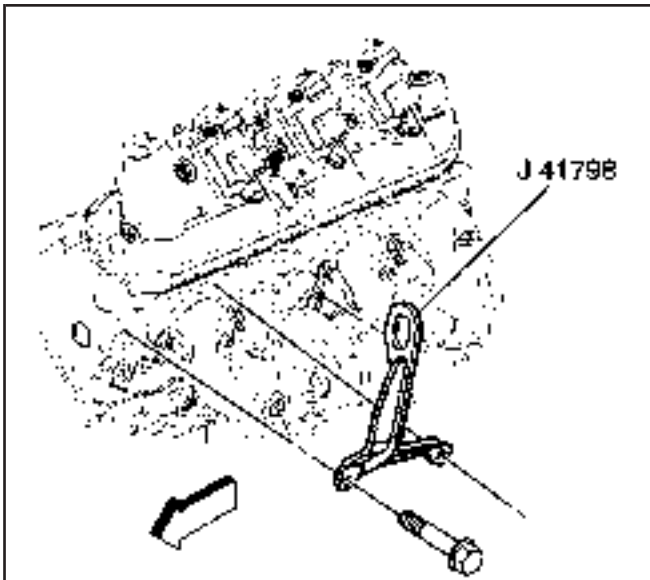
- 73. Remove the *J 41798* from the engine.



394446



309151



309151

Installation Procedure

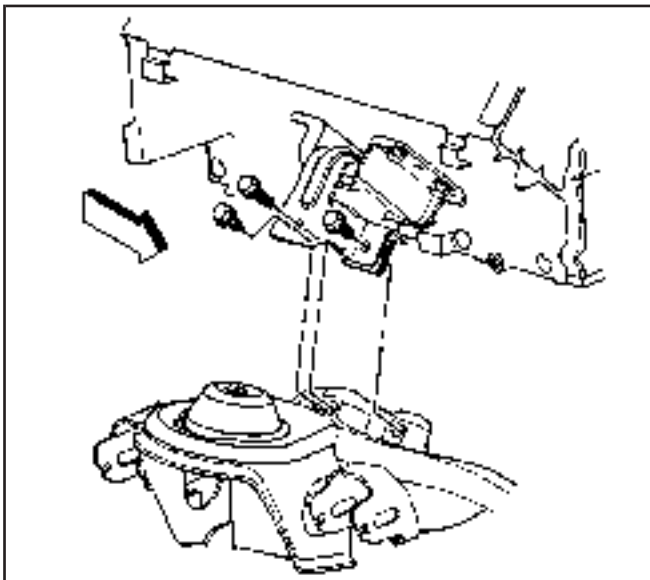
Notice: Refer to *Fastener Notice* in Cautions and Notices.

1. Install the *J 41798* to the engine.

Tighten

- Tighten the M8 engine lift bracket bolts to 25 N·m (18 lb ft).
- Tighten the M10 engine lift bracket bolts to 50 N·m (37 lb ft).

2. Install an engine hoist to the *J 41798*.
3. Remove the engine from the engine stand.
4. Install the engine to the vehicle.
5. Align the engine and transmission.



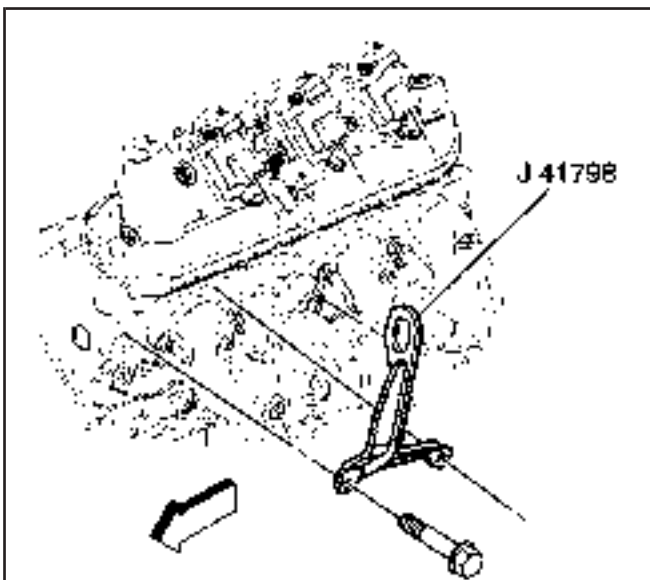
307275

6. Install the left and right engine mount-to-engine mount bracket bolts.

Tighten

Tighten the engine mount-to-engine mount bracket bolts to 65 N·m (48 lb ft).

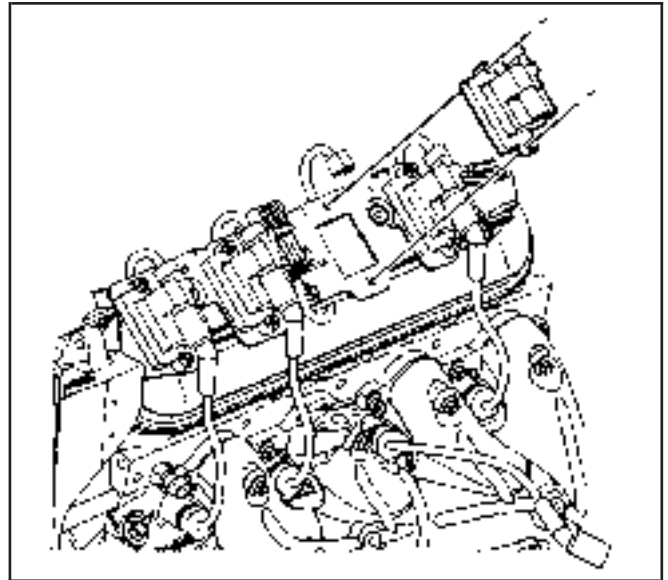
7. Install the upper transmission bolts until snug.
8. Remove the floor jack from under the transmission.
9. Remove the engine hoist.



309151

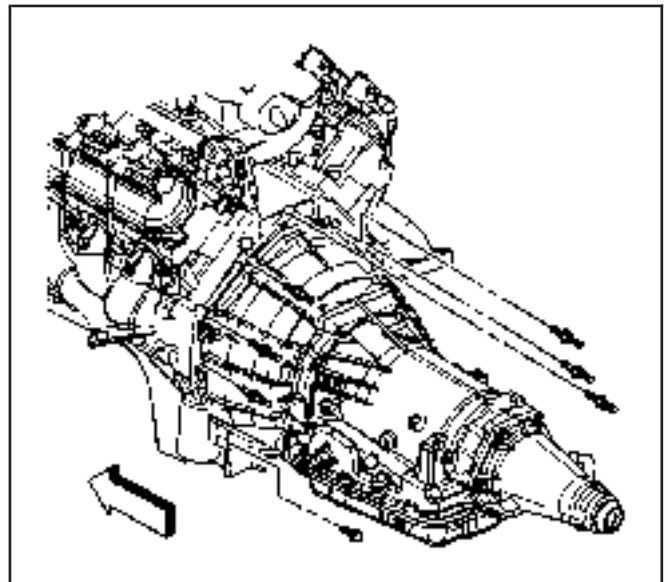
10. Remove the *J 41798* from the engine.

11. Install the ignition coils and the spark plug wires. Refer to *Ignition Coil(s) Replacement* in Engine Controls – 4.8L, 5.3L and 6.0L.
12. Raise the vehicle.



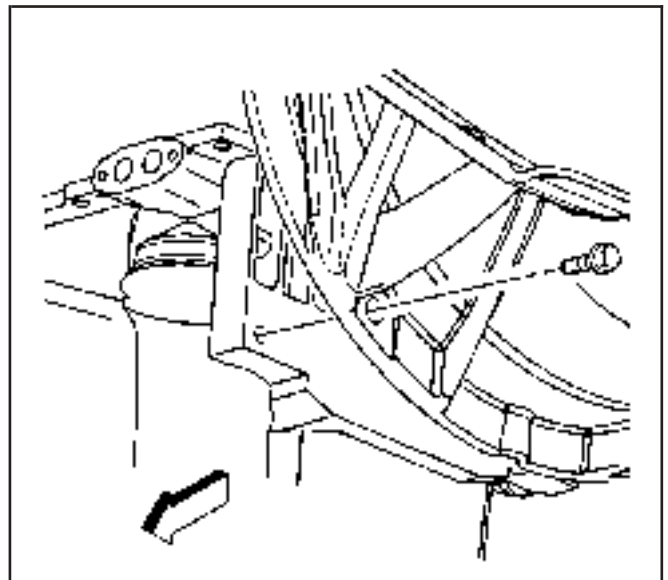
339300

13. Remove the *J 21366* from the transmission.
14. Install the automatic transmission bolt/studs.

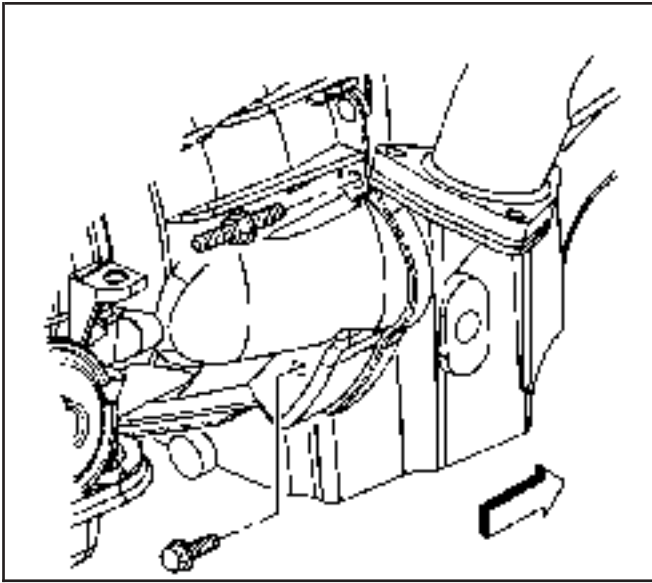


394446

15. If equipped with the 4L80-E automatic transmission, install the transmission converter cover bolts.



396795

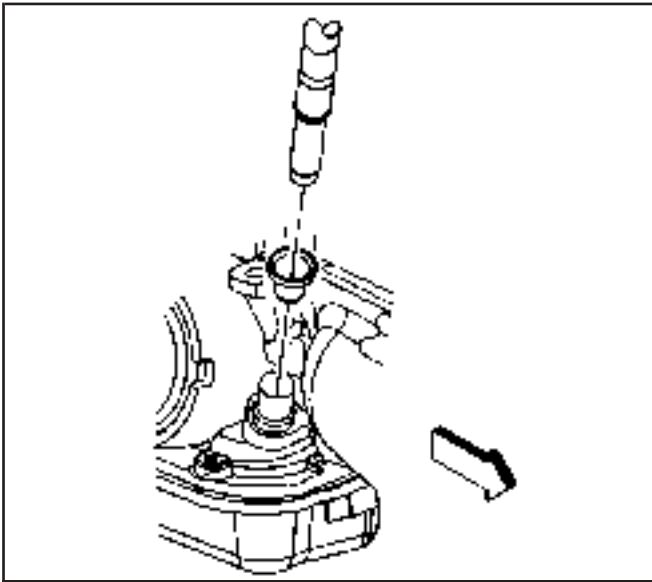


394448

16. If equipped with the 4L60-E automatic transmission, install the transmission bolt and stud on the right side.

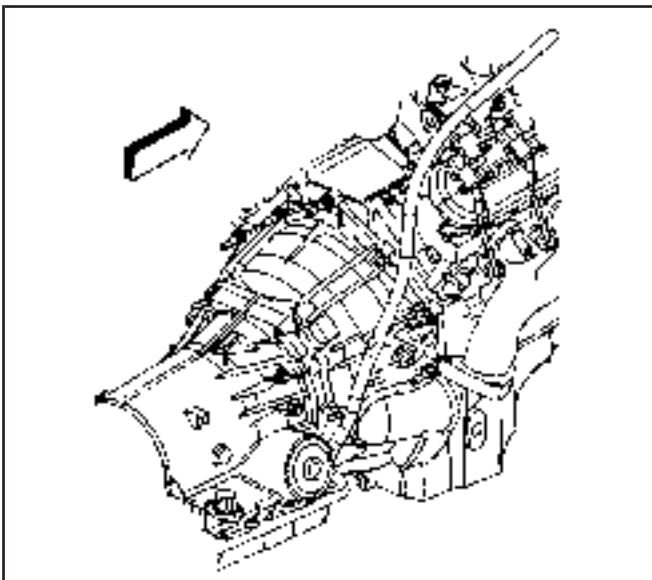
Tighten

Tighten the automatic transmission bolts/studs to 50 N·m (37 lb ft).



396798

17. Install the automatic transmission oil level indicator tube.



396797

18. Install the automatic transmission oil level indicator tube nut.

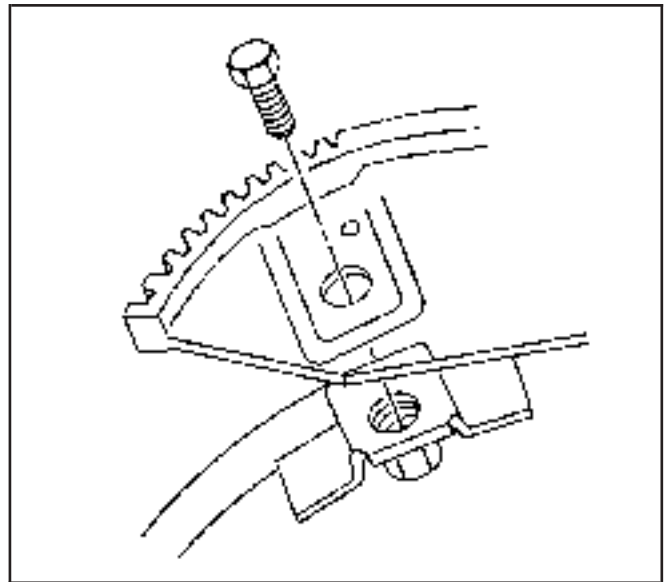
Tighten

Tighten the nut to 18 N·m (13 lb ft).

19. Install the flywheel to torque converter bolts.

Tighten

- If equipped with a 4L60E transmission, tighten the bolts to 63 N·m (47 lb ft).
- If equipped with a 4L80E transmission, tighten the bolts to 60 N·m (44 lb ft).



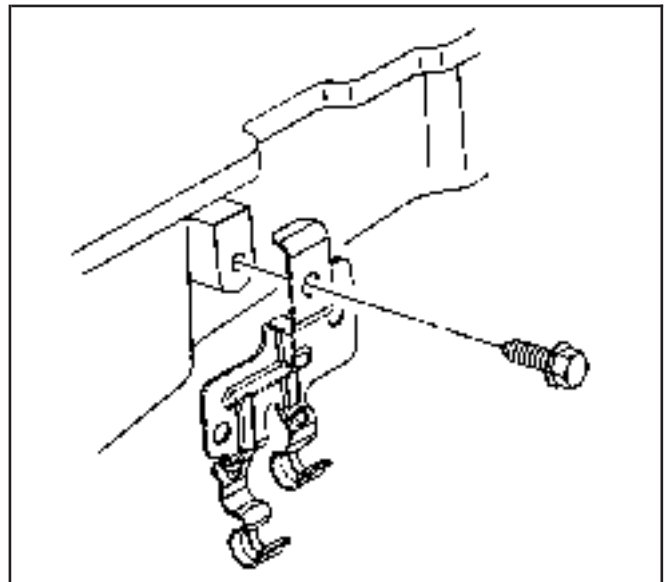
9096

20. Install the positive battery cable clip and bolt.

Tighten

Tighten the bolt to 9 N·m (80 lb in).

21. Install the catalytic converter. Refer to *Catalytic Converter Replacement (4.8L and 5.3L Engines)* or *Catalytic Converter Replacement (6.0L and 8.1L Engines)* in Engine Exhaust.
22. Install the starter motor. Refer to *Starter Motor Replacement (4.8L, 5.3L, and 6.0L Engines)* or *Starter Motor Replacement (8.1L Engine)* in Engine Electrical.

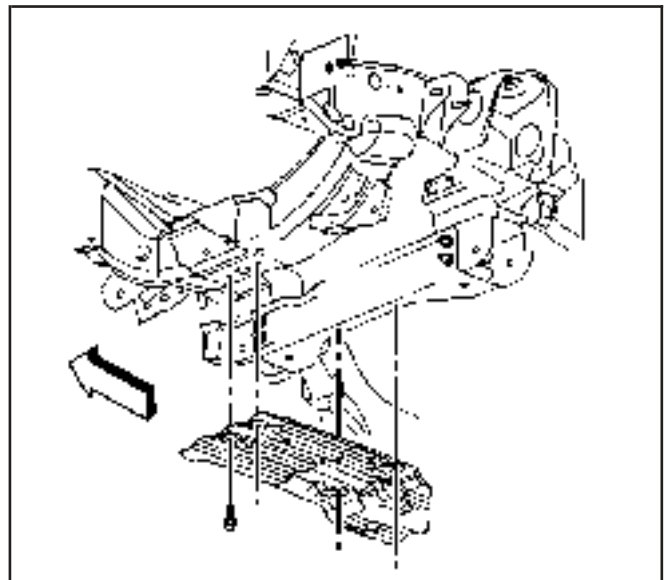


310672

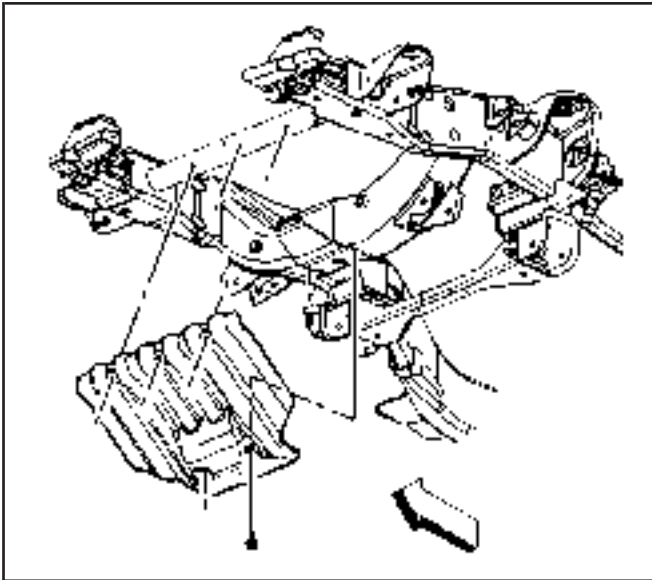
23. Install the oil pan skid plate and bolts, if equipped.

Tighten

Tighten the bolts to 20 N·m (15 lb ft).



309158



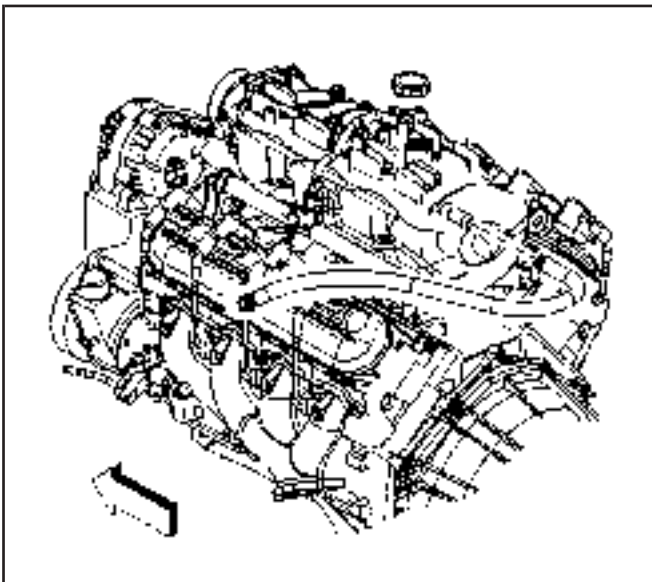
310119

24. Install the engine shield and bolts.

Tighten

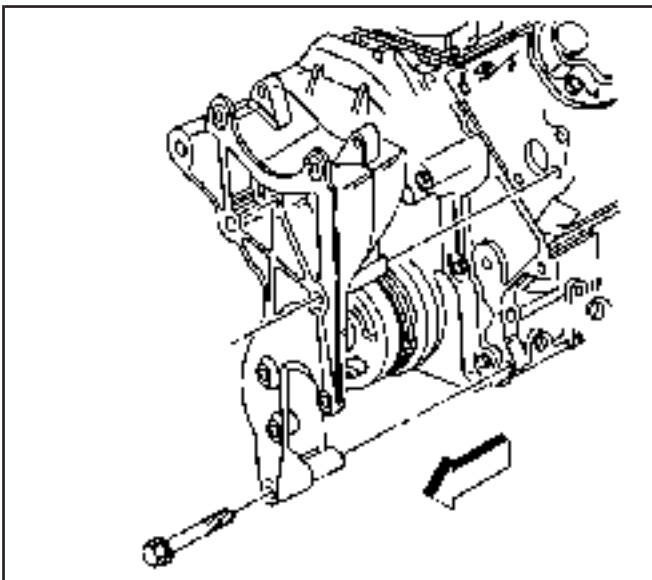
Tighten the bolts to 20 N·m (15 lb ft).

25. Lower the vehicle.



382483

26. Install the vacuum brake booster hose.



310813

27. Position the generator bracket to the front of the engine.

28. Install the generator bracket bolts until snug.

29. Install the rear power steering pump-to-engine block bolt until snug.

Tighten

- Tighten the rear power steering pump bolt to 50 N·m (37 lb ft).

- Tighten the generator bracket bolts to 50 N·m (37 lb ft).

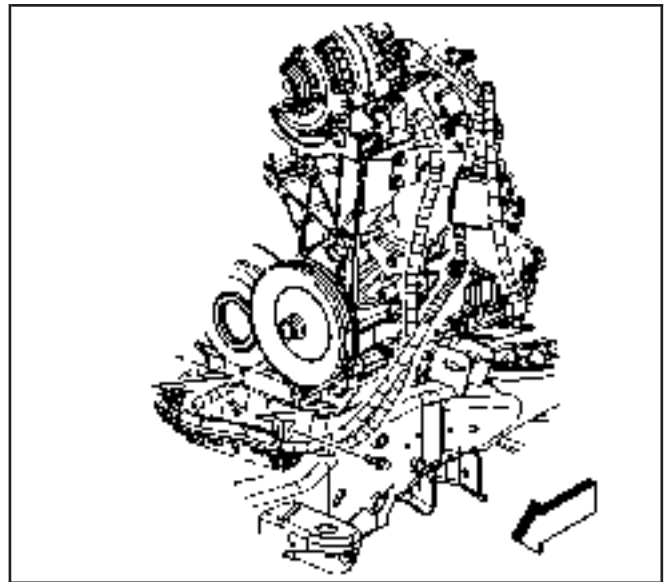
30. Route the engine wiring harness to the lower engine area.

31. Raise the vehicle.

32. Slide the channel pin into the oil pan tab.
33. Install the battery cable channel bolt.

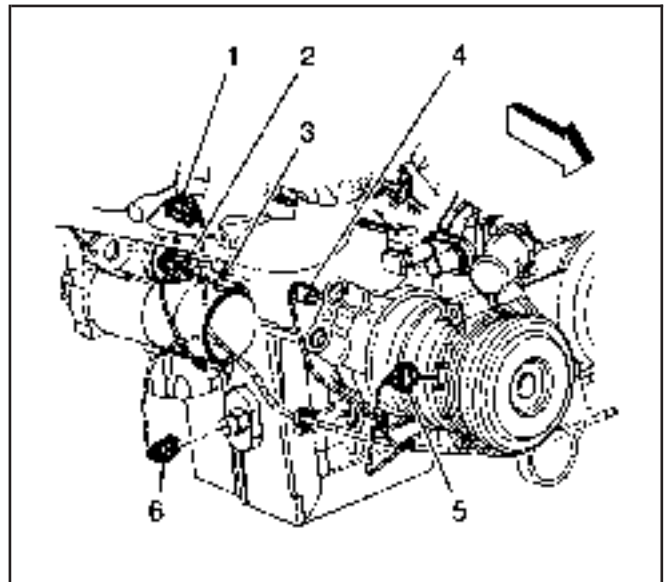
Tighten

Tighten the bolt to 12 N·m (106 lb in).



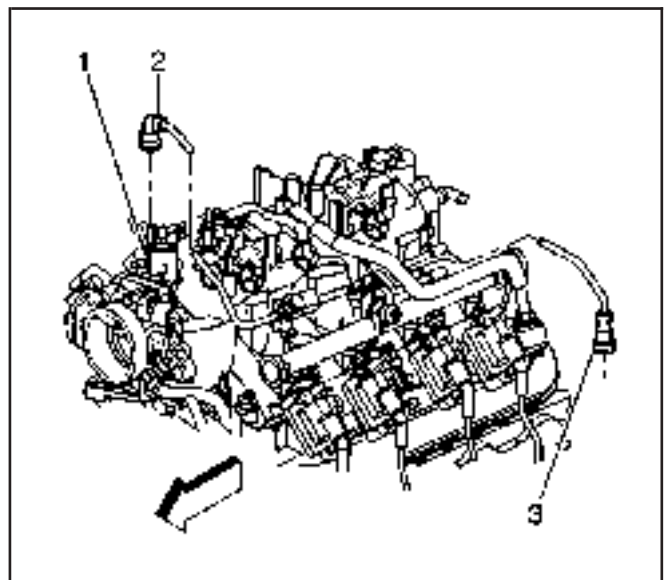
662508

34. Connect the following electrical connectors:
 - The CKP sensor (1)
 - The engine oil level sensor (6)
 - The coolant heater, if equipped
35. Lower the vehicle.
36. Connect the fuel pipes.

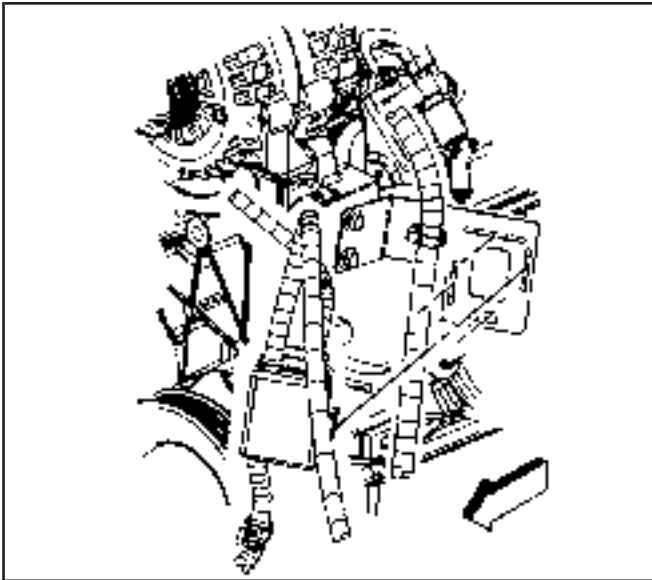


662991

37. Install the EVAP purge solenoid vent tube to the solenoid (1).
38. Install the EVAP tube end (3) to the vapor pipe.

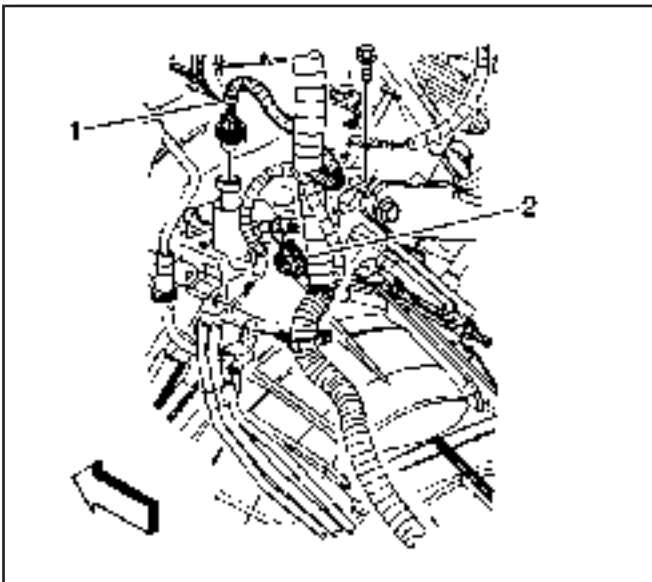


372717



662505

39. Install the battery cable junction block to the junction block bracket.
40. Clip all of the engine wiring harness clips to their correct location.

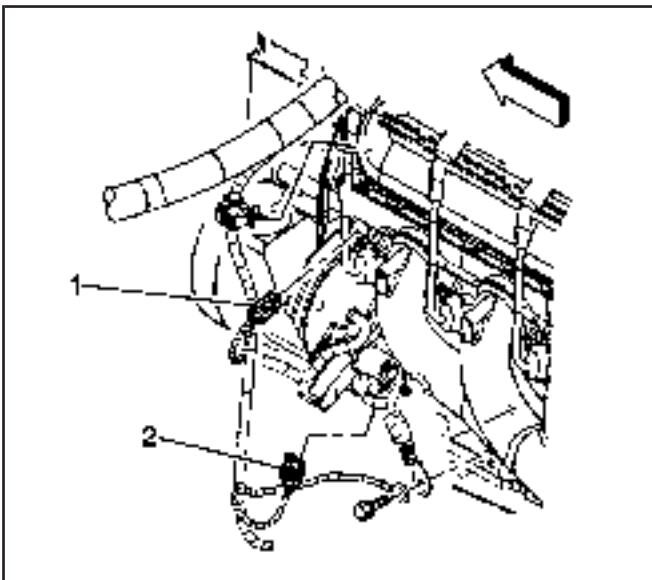


684224

41. Connect the following electrical connectors:
 - The oil pressure sensor (1)
 - The CMP sensor (2)
42. Position the harness ground and the engine ground strap to the block.
43. Install the harness ground bolt at the left rear of the engine block.
44. Position the harness ground, and auxiliary negative battery cable, if equipped to the block.
45. Install the harness ground bolt at the right rear of the engine block.

Tighten

Tighten the bolts to 16 N·m (12 lb ft).



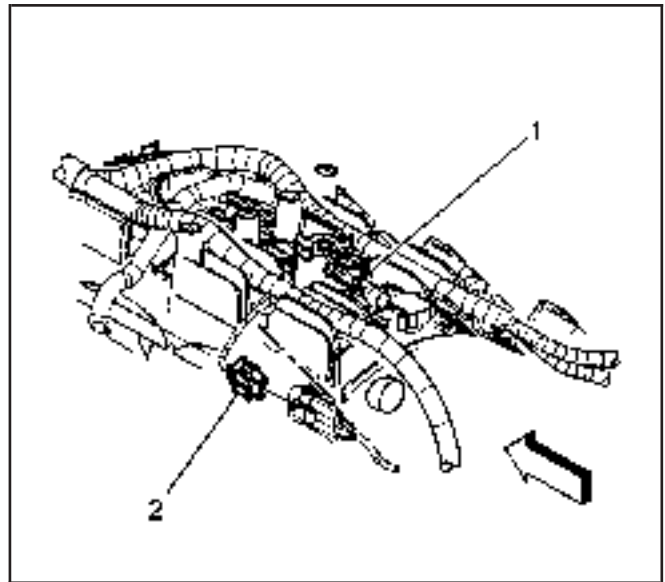
684221

46. Connect the following electrical connectors:
 - The coolant temperature sensor (1)
 - The electronic variable orifice switch (2)
47. Position the harness ground and negative battery cable to the block.
48. Install the harness ground bolt.

Tighten

Tighten the bolt to 25 N·m (18 lb ft).

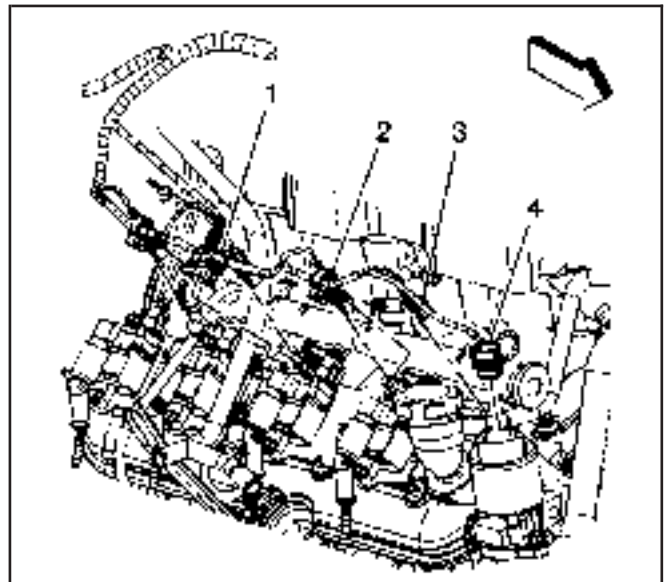
49. Connect the MAP sensor (1) and knock sensor (2) electrical connectors.



679510

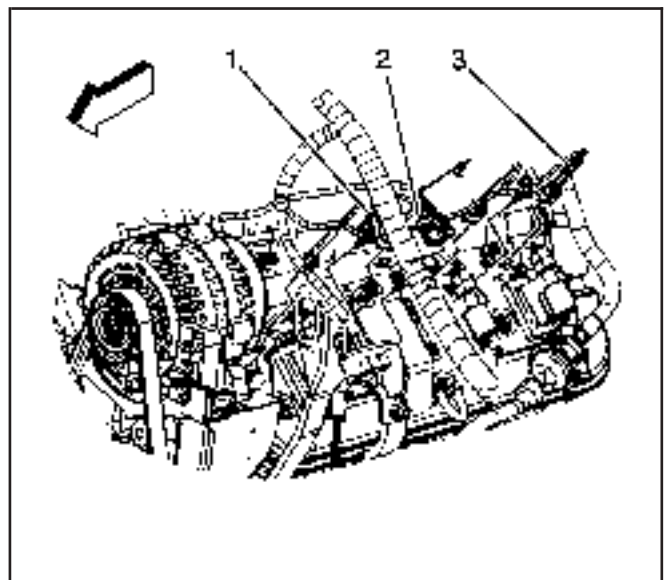
50. Connect the following electrical connectors:

- The main coil harness (1)
- The fuel injectors (3)

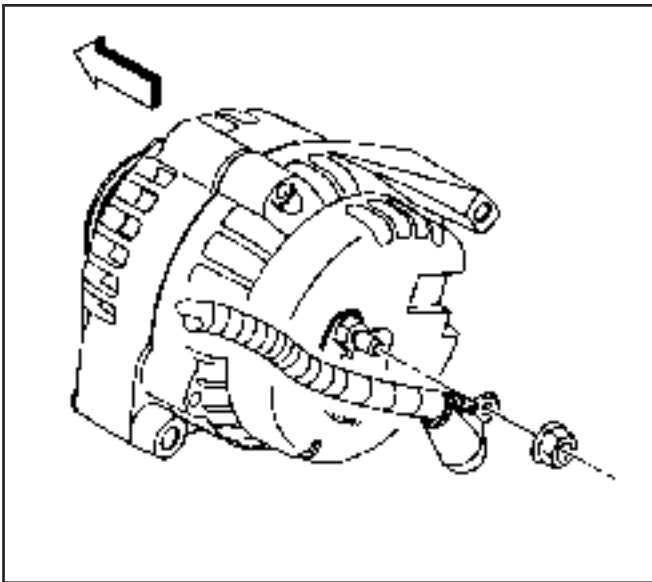


679598

51. Connect the main coil harness (2) and fuel injector (3) electrical connectors on the left side.



679597



395686

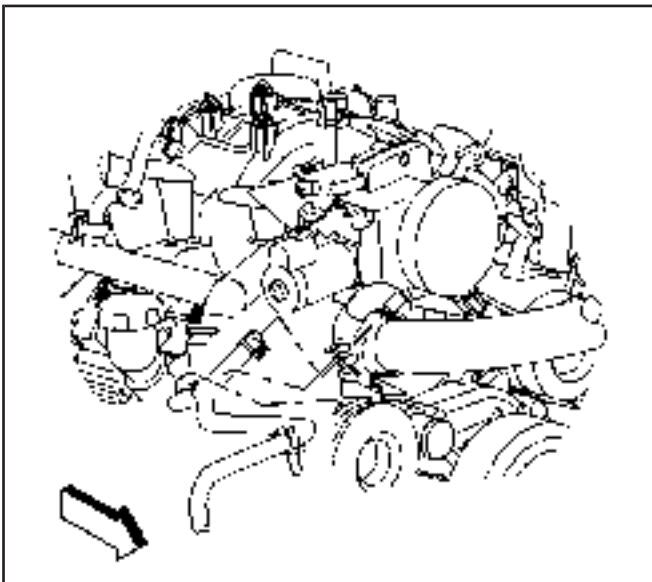
52. Install the generator cable to the generator, perform the following:

- Install the generator cable.
- Install the generator cable nut to the terminal stud.

Tighten

Tighten the nut to 9 N·m (80 lb in).

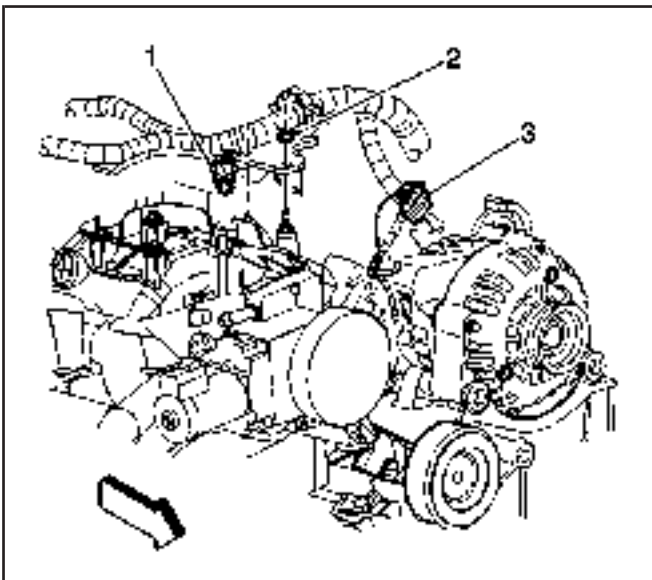
- Slide the boot over the terminal stud.



659465

53. Install the radiator vent inlet hose to the throttle body.

54. Position the vent inlet hose clamp at the throttle body.



663672

55. Install the engine wiring harness bracket and nut (2).

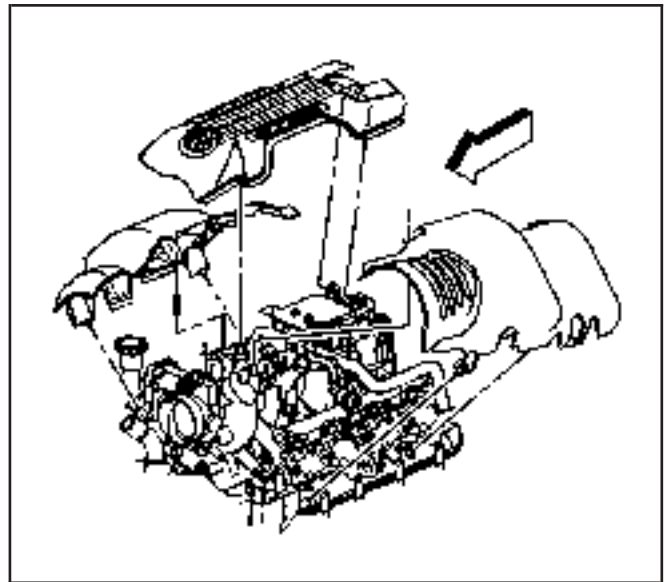
Tighten

Tighten the nut to 5 N·m (44 lb in).

56. Connect the following electrical connectors:

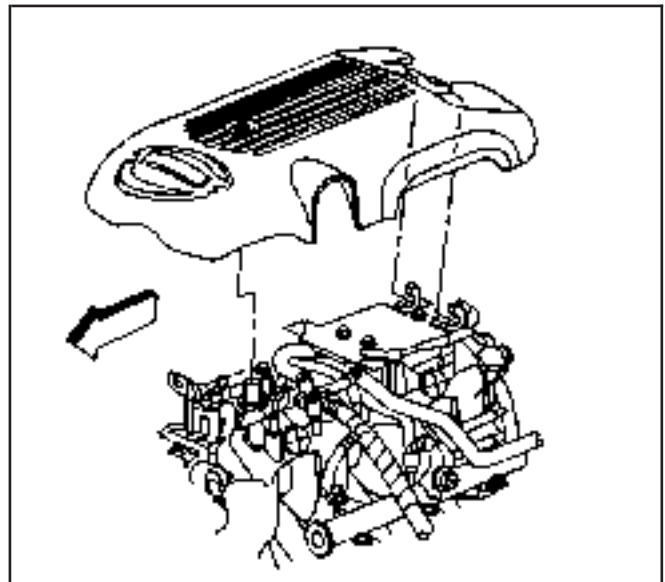
- The EVAP canister purge solenoid (1)
- The Generator (3)
- The ETC

- 57. If equipped with the 6.0L with RPO LQ9, perform the following:
- 58. Install the right fuel rail cover.
- 59. Tighten the right fuel rail cover bolts.
Tighten
 Tighten the bolts to 9 N·m (80 lb in).
- 60. Install the left fuel rail cover.
- 61. Tighten the left fuel rail cover bolts.
Tighten
 Tighten the bolts to 9 N·m (80 lb in).
- 62. Install the sight shield to the retainer.
- 63. Tighten the intake manifold sight shield bolt.
Tighten
 Tighten the bolt to 9 N·m (80 lb in)



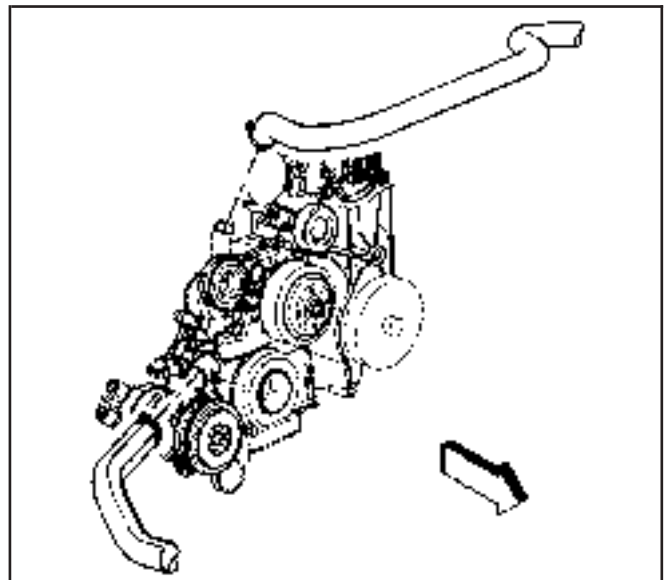
832097

- 64. If equipped with the 4.8L, 5.3L, or 6.0L with RPO LQ4, install the engine sight shield to the retainer.
- 65. Tighten the engine sight shield bolt.
Tighten
 Tighten the bolt to 10 N·m (89 lb in)
- 66. Install the heater hoses. Refer to *Heater Hose Replacement - Inlet (L18)* or *Heater Hose Replacement - Inlet (LR4, LM7, LQ4)* and *Heater Hose Replacement - Outlet (L18)* or *Heater Hose Replacement - Outlet (LR4, LM7, LQ4)* in Heating, Ventilation and Air Conditioning.

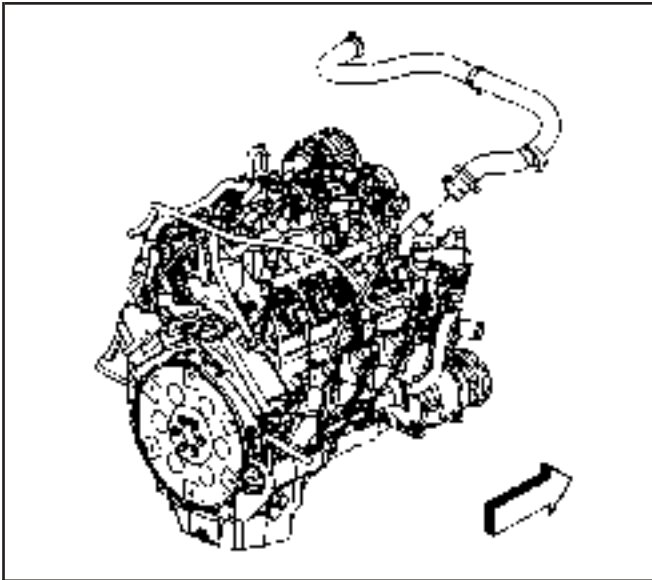


832094

- 67. Install the radiator outlet hose to the water pump.
- 68. Position the radiator outlet hose clamp at the water pump.

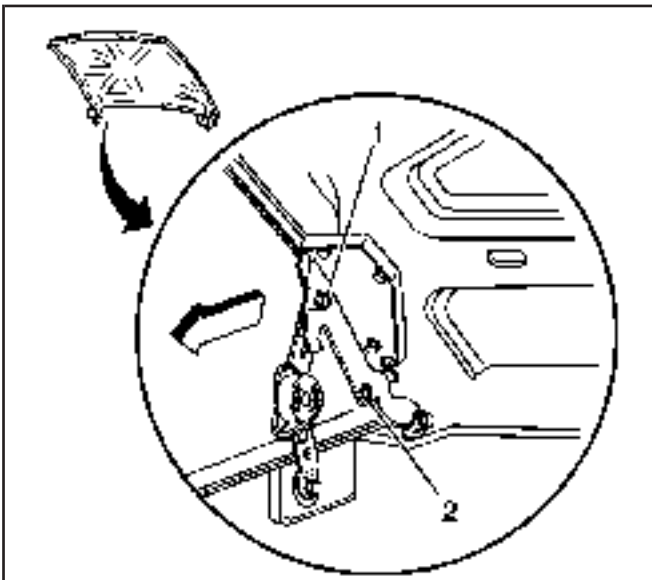


308983



659418

69. Install the radiator inlet hose to the water pump.
70. Position the radiator inlet hose clamp at the water pump.
71. Install the radiator supports. Refer to *Radiator Support Replacement* in Body Front End.
72. Install the A/C compressor. Refer to *Compressor Replacement* in HVAC System - Manual.



310799

73. Remove the hood hinge bolts from the service position (2).
74. Lower the hood to the normal position.
75. Install the hood hinge bolts.

Tighten

Tighten the bolts to 25 N·m (18 lb ft).

76. Remove the fender covers.
77. Perform the engine prelubing procedure. Refer to *Engine Prelubing*.
78. Perform the CKP system variation learn procedure. Refer to *CKP System Variation Learn Procedure* in Engine Controls – 4.8L, 5.3L, and 6.0L.

Important: After an overhaul, the engine should be tested. Use the following procedure after the engine is installed in the vehicle.

- 78.1. Disable the ignition system.
 - 78.2. Crank the engine several times. Listen for any unusual noises or evidence that parts are binding.
 - 78.3. Enable the ignition system.
 - 78.4. Start the engine and listen for unusual noises.
 - 78.5. Check the vehicle oil pressure gauge or light and confirm that the engine has acceptable oil pressure.
 - 78.6. Run the engine speed at about 1000 RPM until the engine has reached normal operating temperature.
 - 78.7. Listen for sticking lifter and other unusual noises.
 - 78.8. Inspect for fuel, oil and/or coolant leaks while the engine is running.
 - 78.9. Perform a final inspection for the proper engine oil and coolant levels.
79. Close the hood.

Engine Oil and Oil Filter Replacement

SIE-ID = 642580 LMD = 28-apr-2000

Removal Procedure

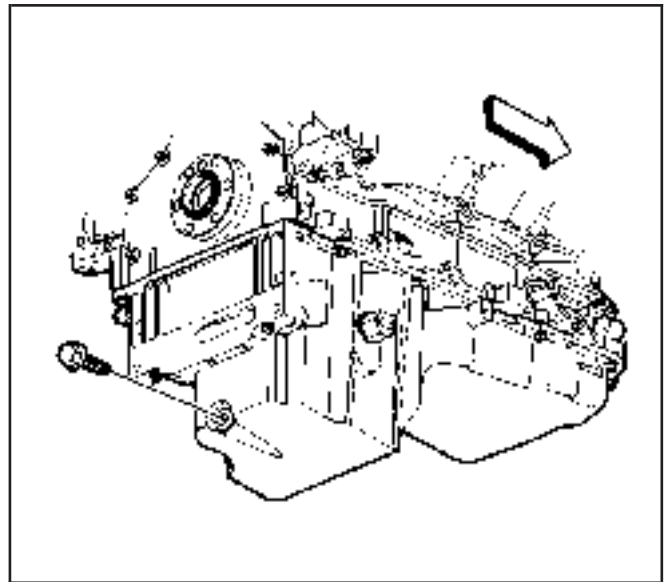
Important: In order to completely drain the oil from the oil pan internal baffling, the bottom of the oil pan must be level during the oil drain procedure.

1. Open the hood.
2. Remove the oil fill cap.
3. Raise and suitably support the vehicle. Refer to *Lifting and Jacking the Vehicle* in General Information.
4. Place a oil drain pan under the oil pan drain plug.
5. Remove the oil pan drain plug.
6. Drain the engine oil.
7. Wipe the excess oil from the drain plug hole and plug.

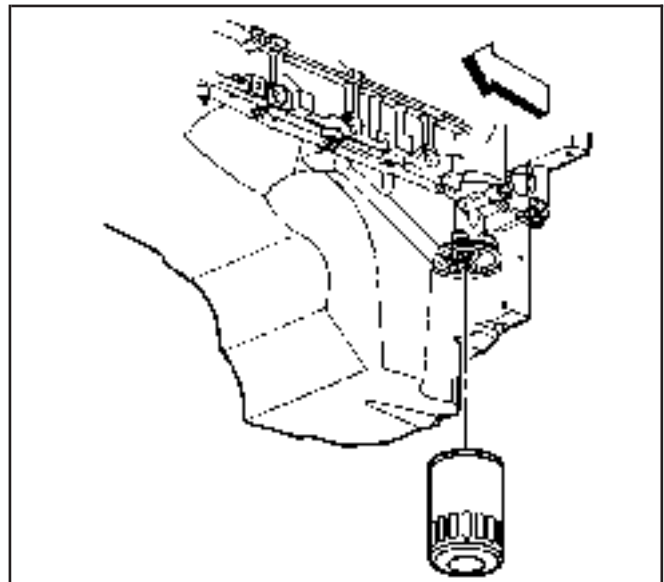
8. Remove the oil filter from the engine block.

Important: Check the old oil filter to ensure that the filter seal is not left on the engine block.

9. Wipe the excess oil from the oil filter mounting.



260111



260117

Installation Procedure

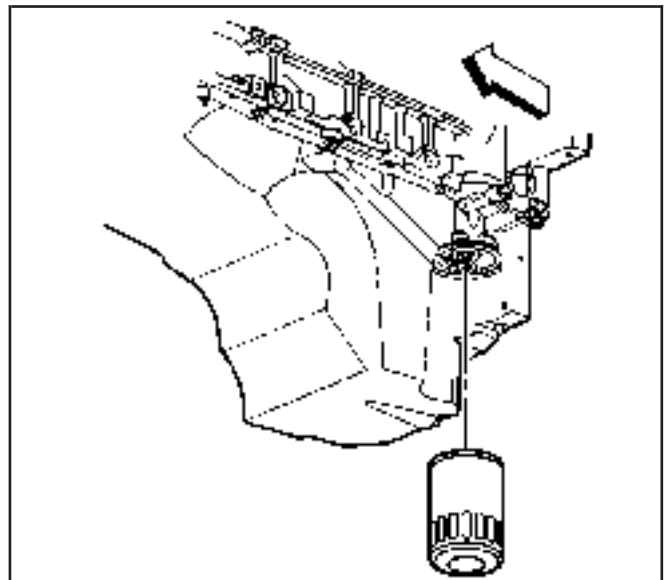
1. Lubricate the oil filter seal with clean engine oil.

Notice: Refer to *Fastener Notice* in Cautions and Notices.

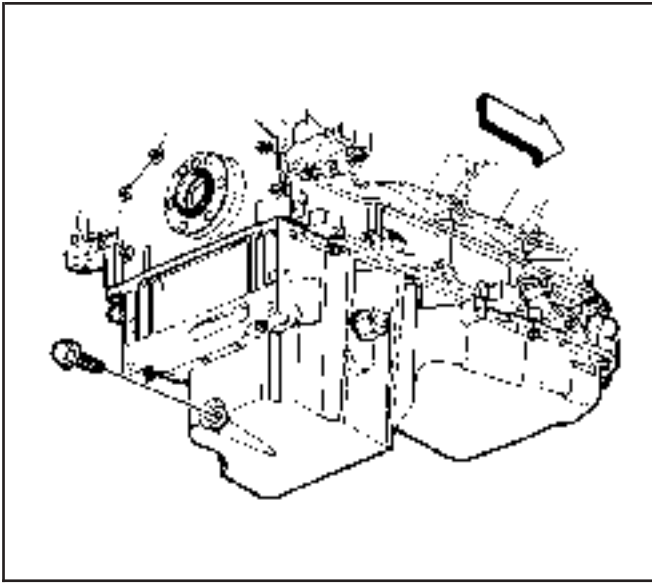
2. Install the oil filter to the engine block.

Tighten

Tighten the oil filter to 30 N·m (22 lb ft).

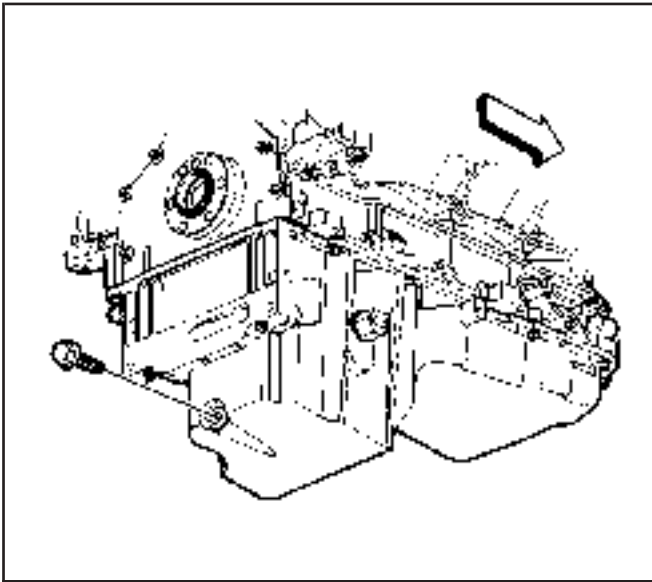


260117



260111

3. Install the oil drain plug to the engine block.
- Tighten**
Tighten the oil pan drain plug to 25 N-m (18 lb ft).
4. Lower the vehicle.
5. Fill the crankcase with the proper quantity and grade of engine oil. Refer to *Capacities - Approximate Fluid* and *Fluid and Lubricant Recommendations* in Maintenance and Lubrication.
6. Remove the oil level indicator.
7. Wipe the indicator with a clean cloth.
8. Install the oil level indicator.
9. Remove the oil level indicator in order to check the level.
10. Add oil if necessary.
11. Close the hood.



260111

Draining Fluids and Oil Filter Removal

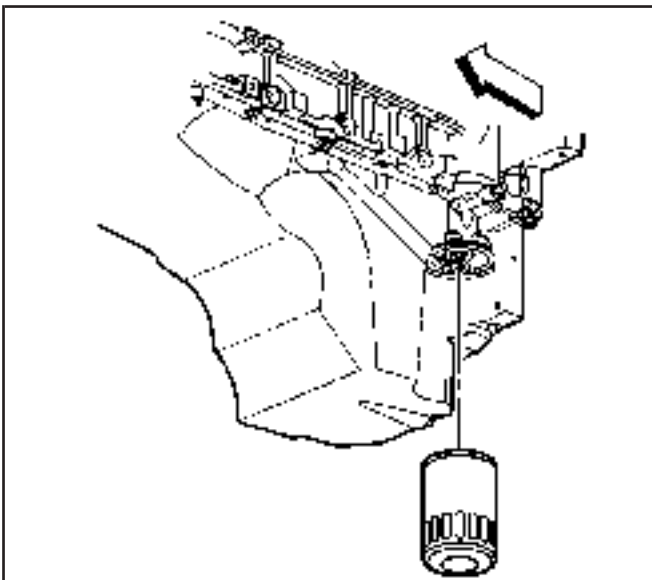
SIE-ID = 823807 LMD = 26-feb-2002

Tools Required

J 41712 Oil Pressure Switch Socket

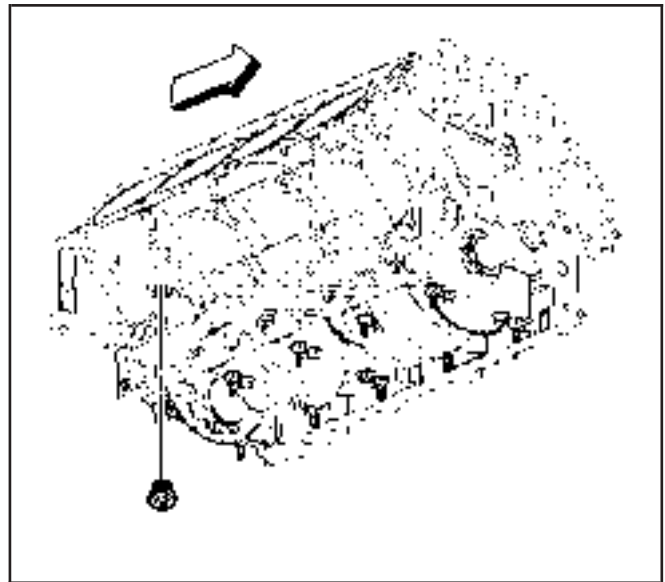
Important: In order to completely drain the oil, the bottom of the oil pan must be level during the oil drain procedure.

1. Remove the oil pan drain plug and allow the oil to drain.
2. Remove the engine oil filter.



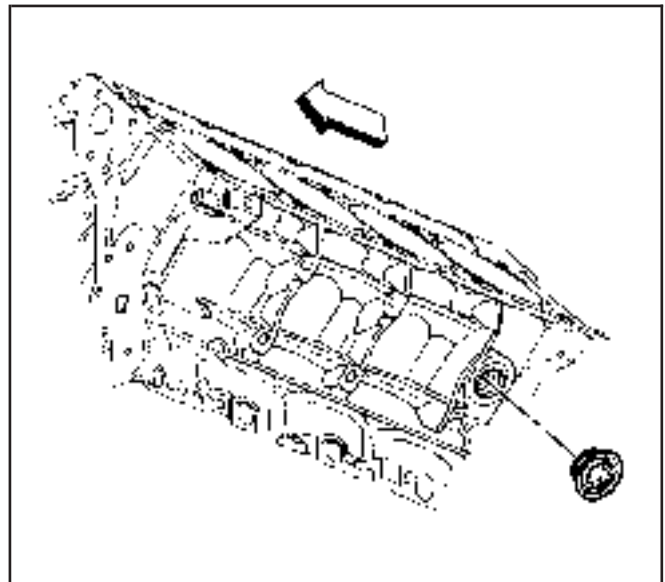
260117

- 3. Remove the right rear engine block coolant drain plug and allow the coolant to drain.



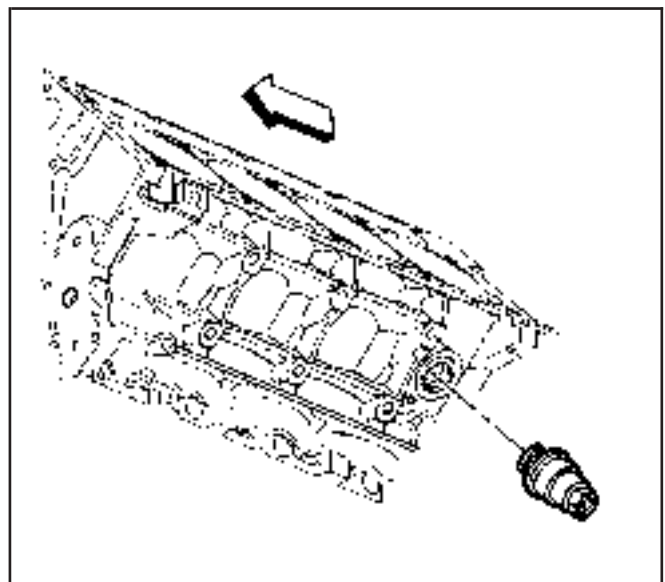
63164

- 4. Remove the left rear engine block coolant drain plug, if applicable, and allow the coolant to drain.

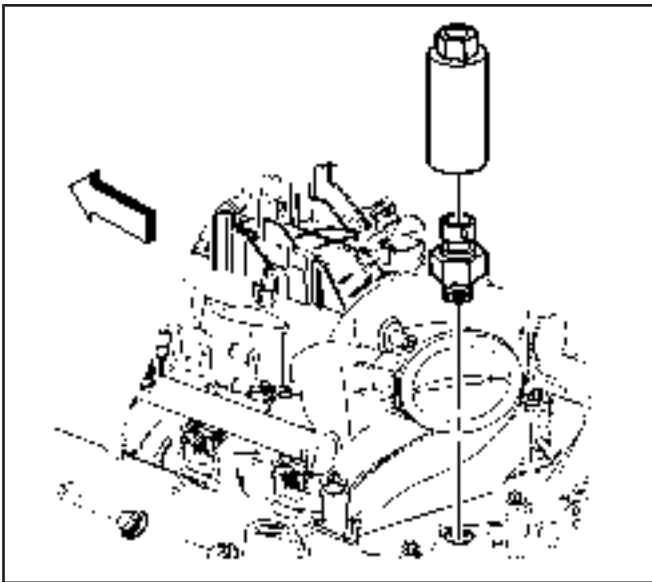


260138

- 5. Remove the engine block coolant heater, if applicable, and allow the coolant to drain.

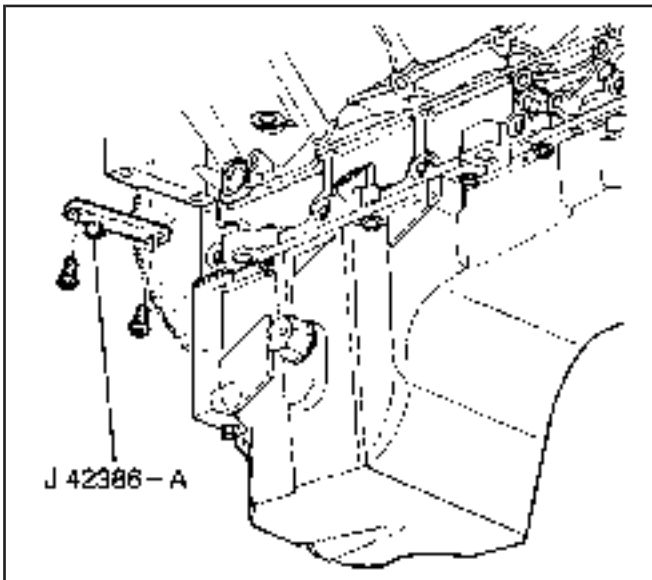


260137



823316

- Use the *J 41712* or equivalent in order to remove the oil pressure sensor, if required.



260126

Crankshaft Balancer Removal

SIE-ID = 280657 LMD = 18-mar-2002

Tools Required

- *J 41816* Crankshaft Balancer Remover
- *J 41816-2* Crankshaft End Protector
- *J 42386-A* Flywheel Holding Tool

Notice: Refer to *Fastener Notice* in Cautions and Notices.

Important:

- Do not use the crankshaft balancer bolt again. Install a NEW crankshaft balancer bolt during final assembly.
- Ensure the teeth of the flywheel holding tool mesh with the teeth of the engine flywheel.

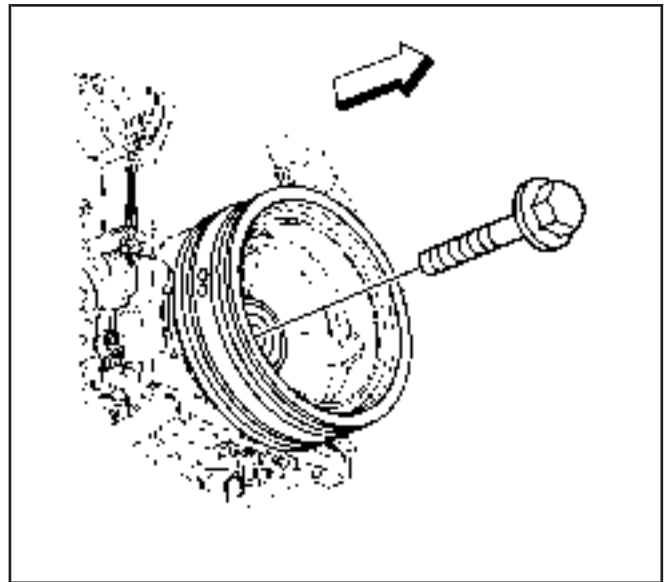
1. Install the *J 42386-A* and bolts.

Use one M10 – 1.5 x 120 mm and one M10 – 1.5 x 45 mm bolt for proper tool operation.

Tighten

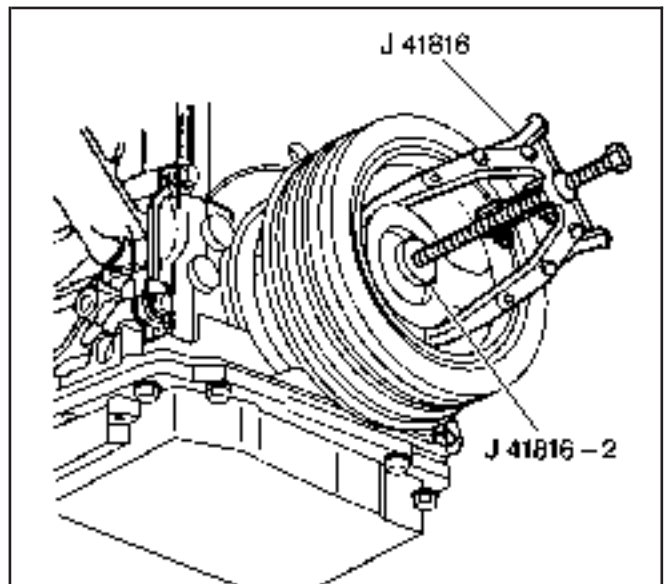
Tighten the *J 42386-A* bolts to 50 N·m (37 lb ft).

2. Remove the crankshaft balancer bolt.
Do not discard the crankshaft balancer bolt. The balancer will be used during the balancer installation procedure.



260154

3. Use the *J 41816* and the *J 41816-2* in order to remove the crankshaft balancer.
4. Remove the *J 42386-A* and bolts.



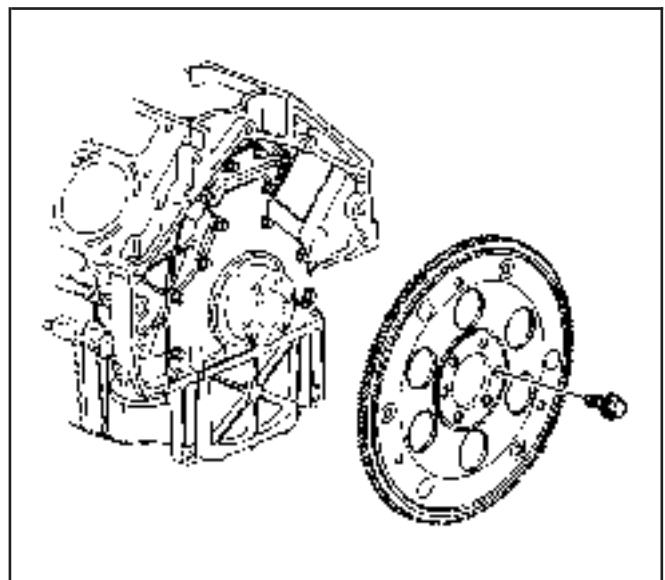
156164

Engine Flywheel Removal

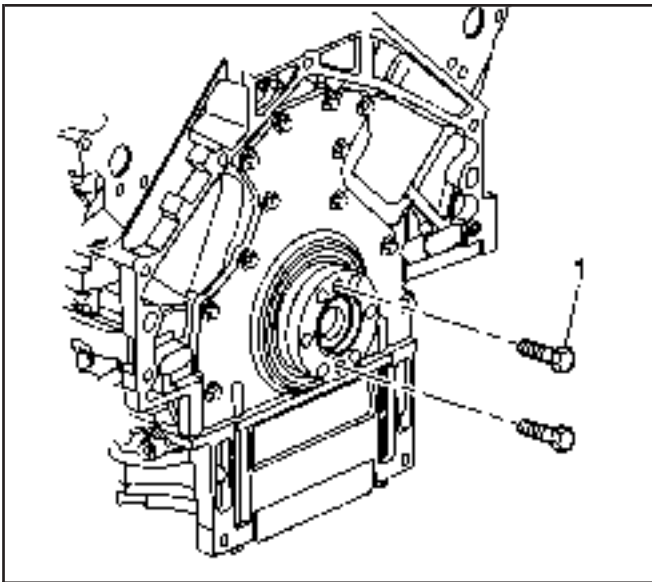
SIE-ID = 824403 LMD = 21-mar-2002

Important: The flywheel does not use a locating pin for alignment and will not initially seat against the crankshaft flange or spacer, if applicable, but will be pulled onto the crankshaft by the engine flywheel bolts. This procedure requires a 3 stage tightening process.

1. Remove the engine flywheel bolts.
2. Remove the automatic transmission engine flywheel.

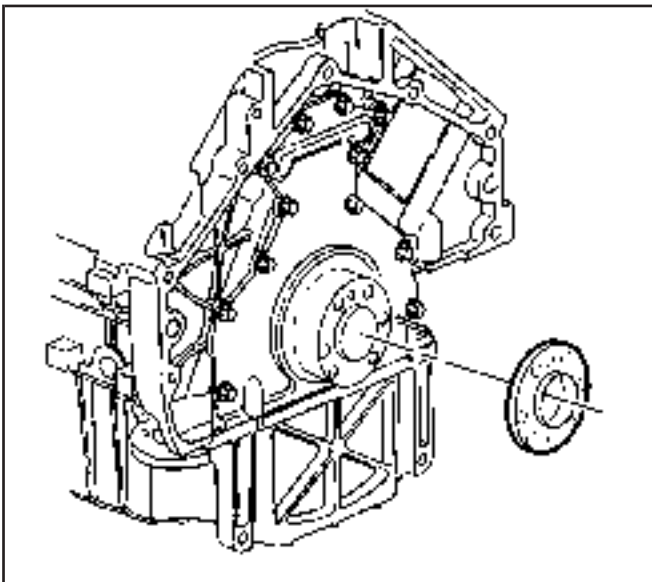


178458



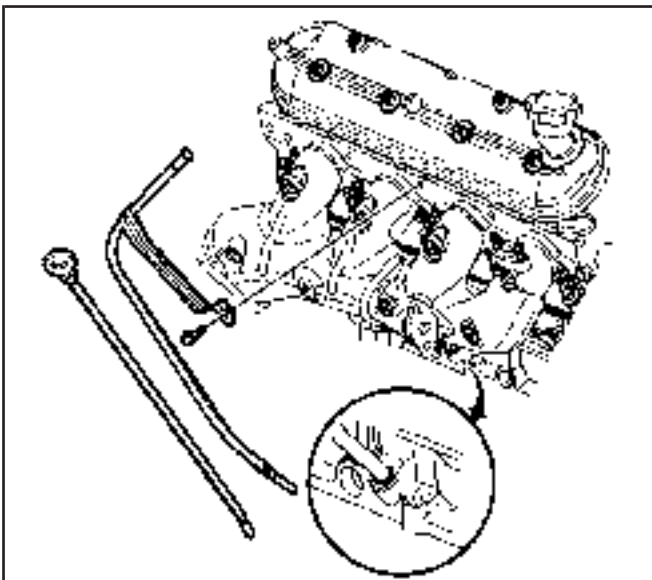
642281

3. Install 2 M11x1.5 mm bolts (1) into the threaded holes of the spacer, if applicable.
4. Rotate the bolts clockwise to remove the spacer.



642276

5. Remove the spacer from the rear of the crankshaft, if applicable.



260114

Oil Level Indicator and Tube Removal

SIE-ID = 280658 LMD = 18-mar-2002

1. Remove the oil level indicator from the tube.
2. Remove the oil level indicator tube bolt.
3. Remove the oil level indicator tube from the engine block.

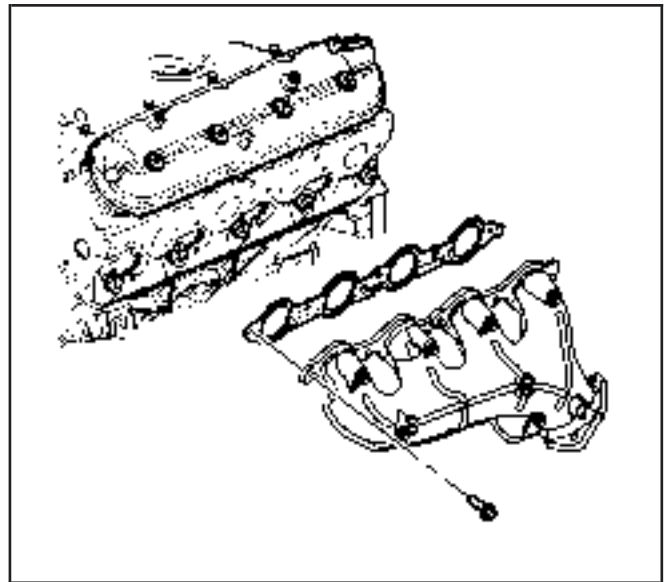
Important: Inspect the O-ring seal for cuts or damage. The O-ring seal may be used again if it is not cut or damaged.

4. Remove the O-ring seal from the tube, if required.

Exhaust Manifold Removal - Left

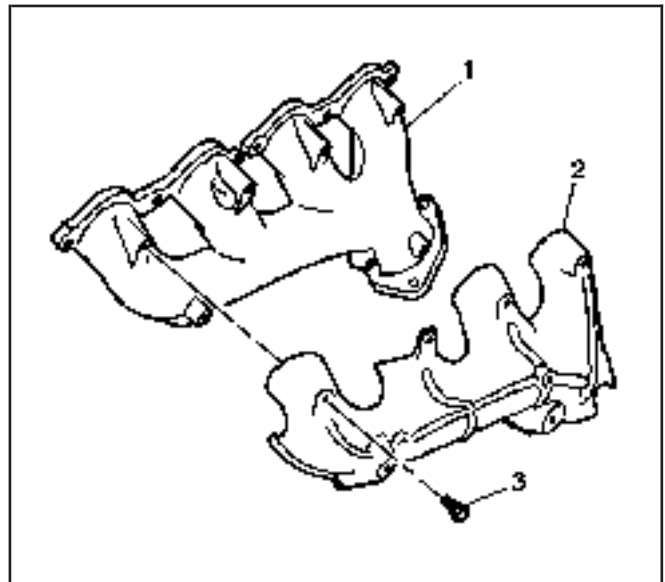
SIE-ID = 741674 LMD = 27-dec-2000

1. Remove the spark plug wires from the spark plugs.
Do not remove the spark plug wires from the ignition coils unless required.
2. Remove the exhaust manifold, bolts, and gasket.
3. Discard the gasket.



741552

4. Remove the heat shield (2) and bolts (3) from the manifold (1), if required.

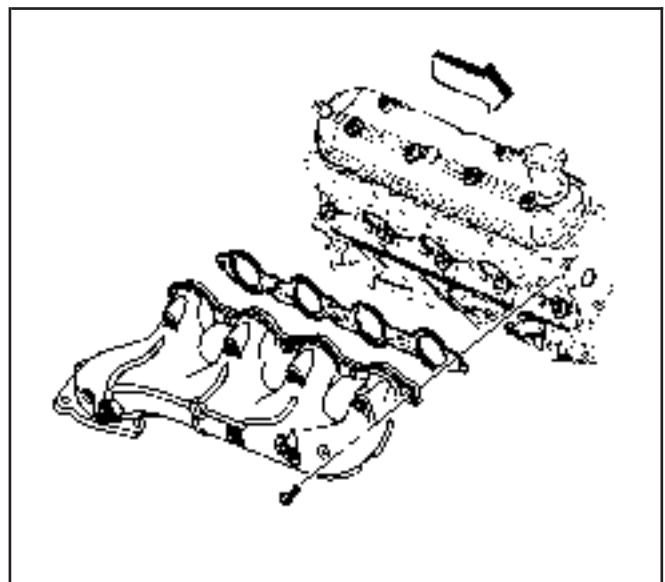


492766

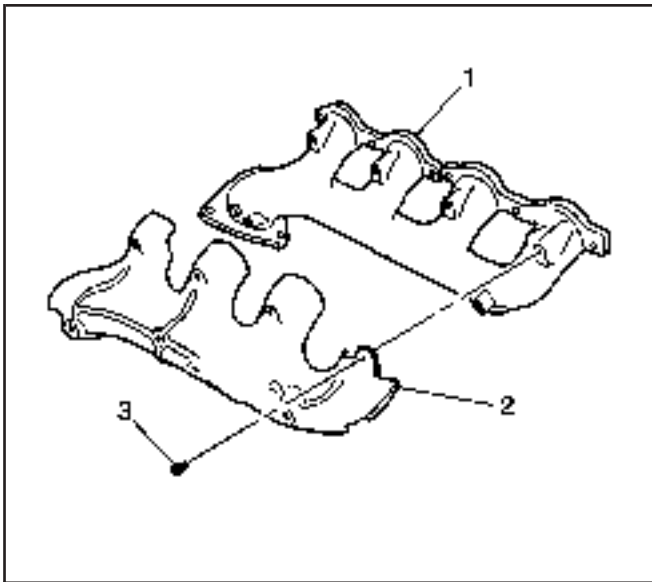
Exhaust Manifold Removal - Right

SIE-ID = 823810 LMD = 03-oct-2001

1. Remove the spark plug wires from the spark plugs.
Do not remove the spark plug wires from the ignition coils unless required.
2. Remove the exhaust manifold, bolts, and gasket.
3. Discard the gasket.

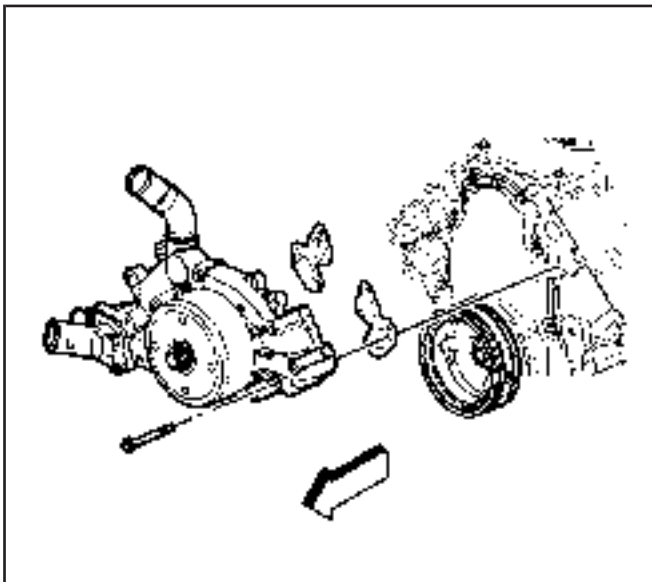


823317



823320

4. Remove the heat shield (2) and bolts (3) from the manifold (1), if required.

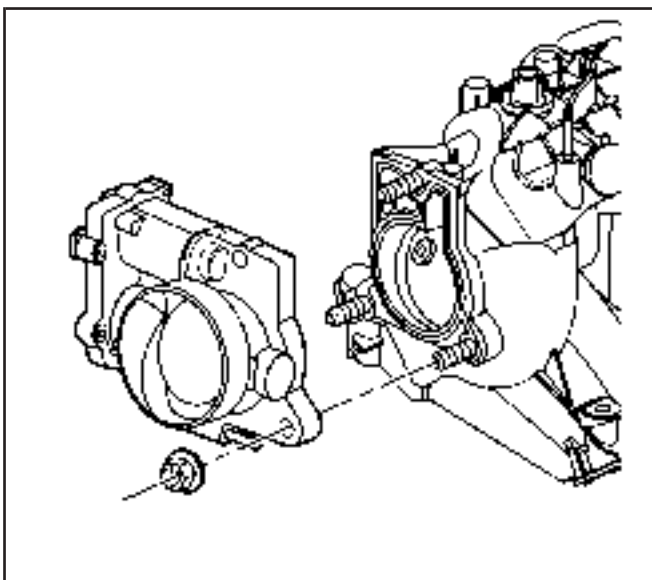


260121

Water Pump Removal

SIE-ID = 667801 LMD = 25-jan-2000

1. Remove the water pump bolts.
2. Remove the water pump and gaskets.
3. Discard the water pump gaskets.



825837

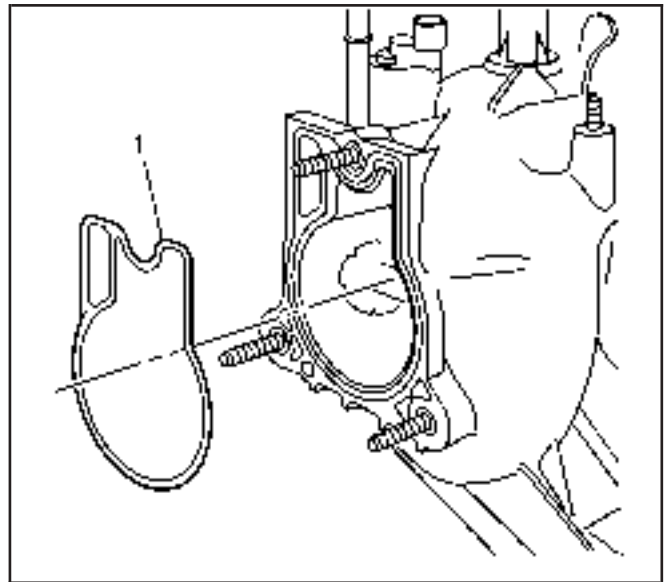
Throttle Body Removal

SIE-ID = 826627 LMD = 18-oct-2001

Important: The intake manifold, throttle body, fuel injection rail, and fuel injectors may be removed as an assembly. If not servicing the individual components, remove the manifold as a complete assembly.

1. Remove the electrical wire harness connectors from the throttle body.
2. Remove the engine coolant air bleed hose and clamp.
3. Remove the throttle body nuts.
4. Remove the throttle body.

5. Remove the throttle body gasket (1).
6. Discard the gasket.
7. Remove the throttle body studs, if required.



492774

Fuel Rail and Injectors Removal

SIE-ID = 280667 LMD = 11-may-2001

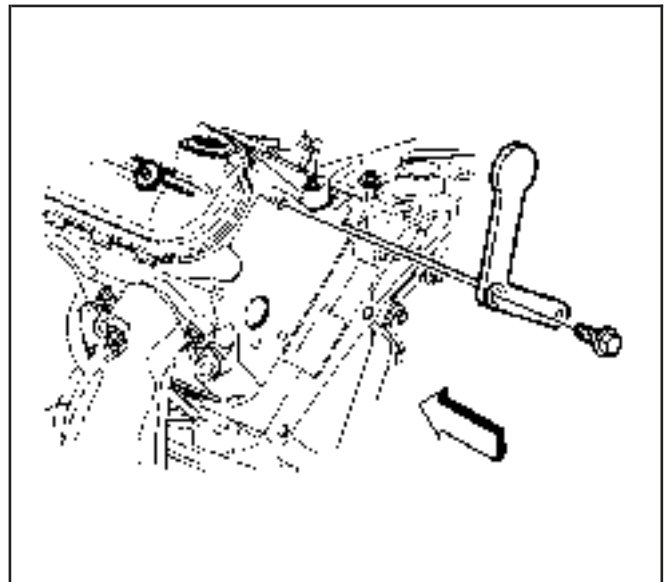
Caution: Refer to Fuel Rail Stop Bracket Installation Caution in Cautions and Notices.

Notice: SIO-ID = 19157 LMD = 25-sep-1996

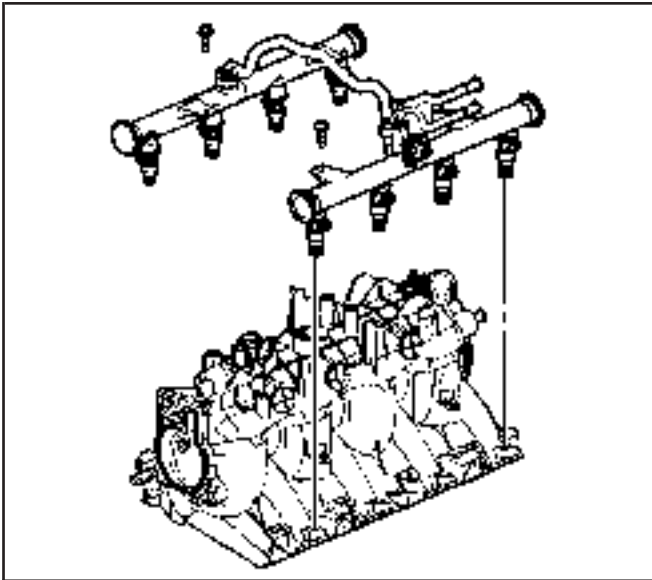
- Remove the fuel rail assembly carefully in order to prevent damage to the injector electrical connector terminals and the injector spray tips. Support the fuel rail after the fuel rail is removed in order to avoid damaging the fuel rail components.
- Cap the fittings and plug the holes when servicing the fuel system in order to prevent dirt and other contaminants from entering open pipes and passages.

Important: The intake manifold, throttle body, fuel injection rail and fuel injectors may be removed as an assembly. If not servicing the individual components, remove the intake manifold as a complete assembly.

1. Remove the fuel rail stop bracket and bolt, if required.
2. Remove the vacuum hose from the fuel pressure regulator.



260098



260176

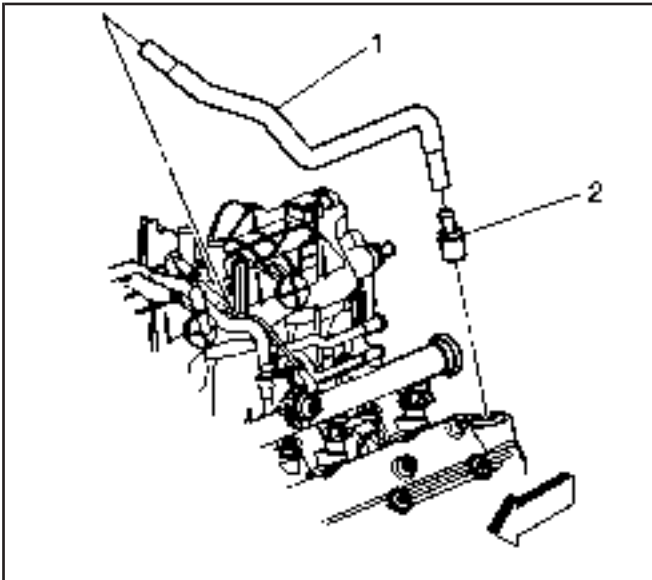
3. Loosen the crossover tube-to-right fuel rail retaining bolt.
4. Remove the fuel rail bolts.

Important: Do not separate the fuel injectors from the fuel rail unless component service is required.

Use cleanliness and care when handling the fuel system components.

Do not allow dirt or debris to enter the fuel injectors or fuel rail components, cap ends as necessary.

5. Remove the fuel rail, with injectors, lifting evenly from both sides of the fuel rail until all the injectors have left their bores.



869526

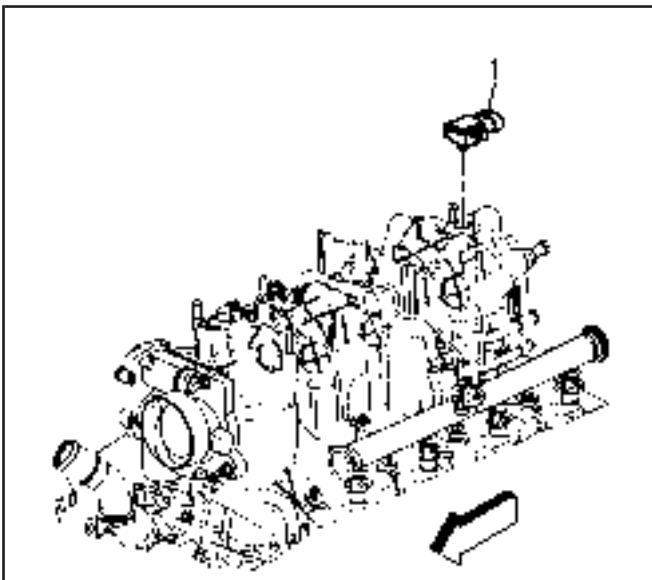
Intake Manifold Removal

SIE-ID = 863432 LMD = 25-mar-2002

Important: The intake manifold, throttle body, fuel injection rail, and fuel injectors may be removed as an assembly. If not servicing the individual components, remove the manifold as a complete assembly.

DO NOT use the intake manifold-to-cylinder head gaskets again.

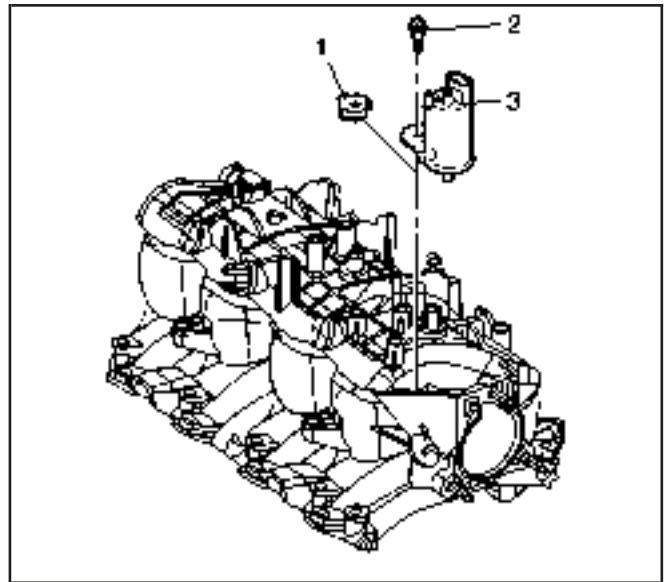
1. Remove the positive crankcase ventilation (PCV) hose (1) and valve (2).



863068

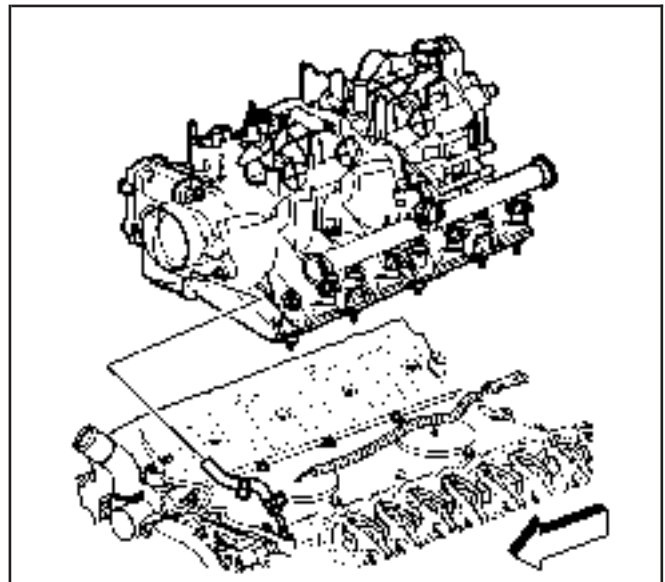
2. Remove the manifold absolute pressure (MAP) sensor (1), if required.
3. Remove the engine coolant air bleed clamp and hose from the throttle body.

4. Remove the evaporative emission (EVAP) solenoid (3), bolt (2), and isolator (1).



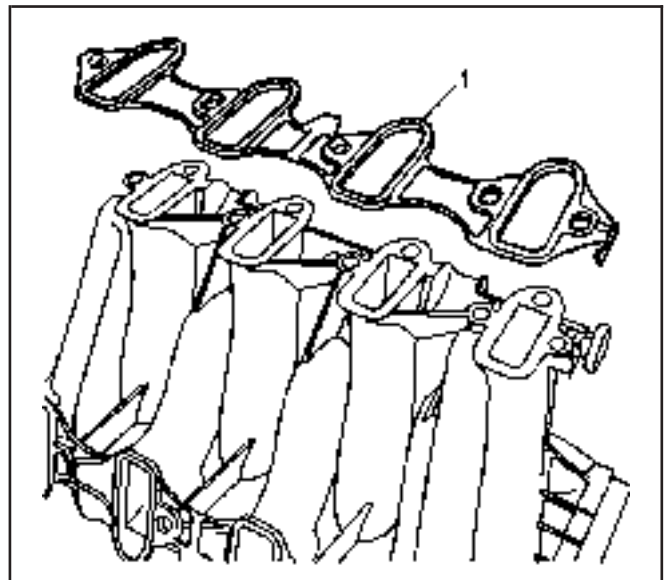
869529

5. Remove the intake manifold bolts.
6. Remove the intake manifold with gaskets.



863069

7. Separate the intake manifold-to-cylinder head gaskets (1) from the manifold.
8. Discard the intake manifold gaskets.

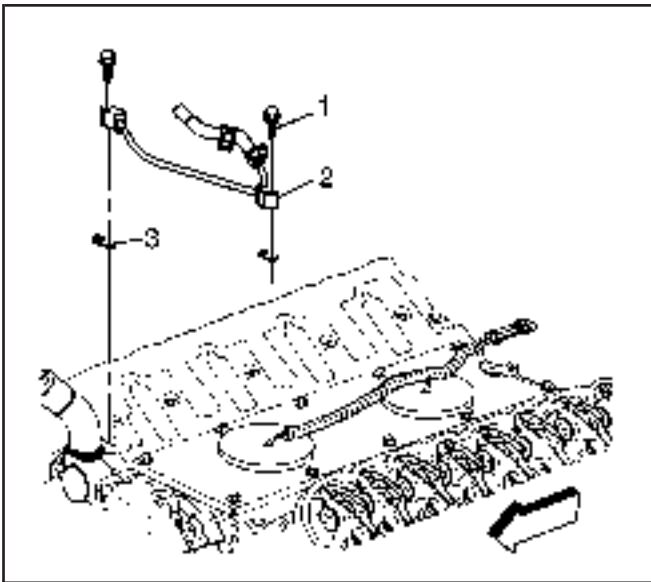


492770

Coolant Air Bleed Pipe Removal

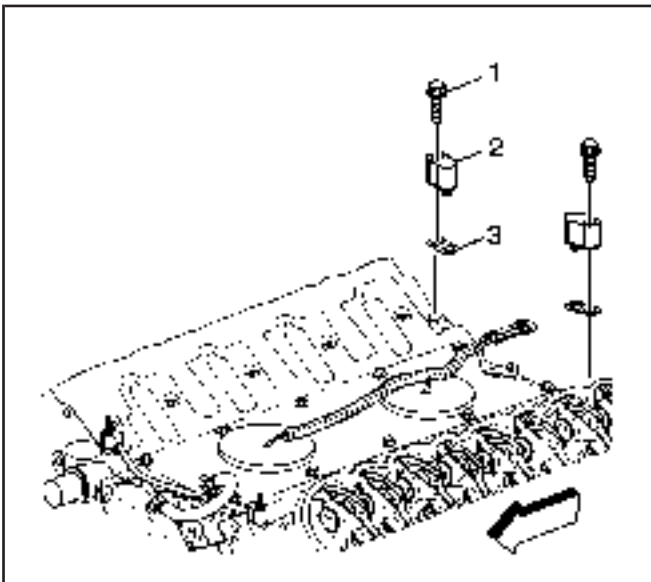
SIE-ID = 741676 LMD = 29-mar-2001

1. Remove the engine coolant air bleed pipe bolts (1).
2. Remove the pipe (2) and gaskets (3).



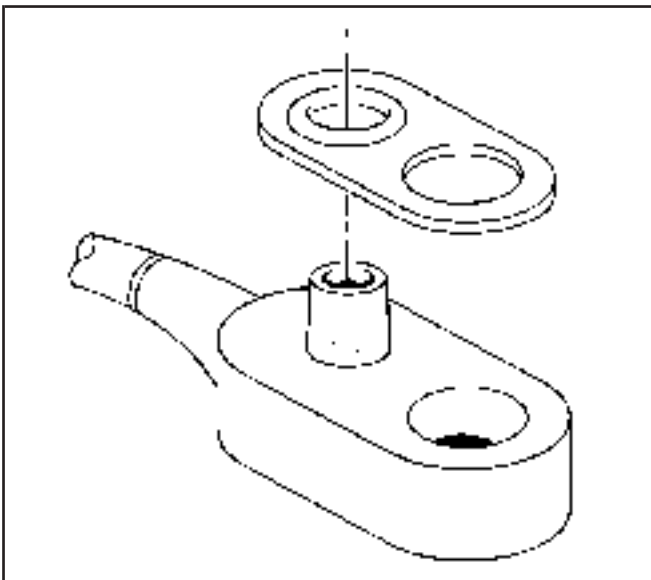
741555

3. Remove the engine coolant air bleed pipe cover bolts (1) and covers (2).



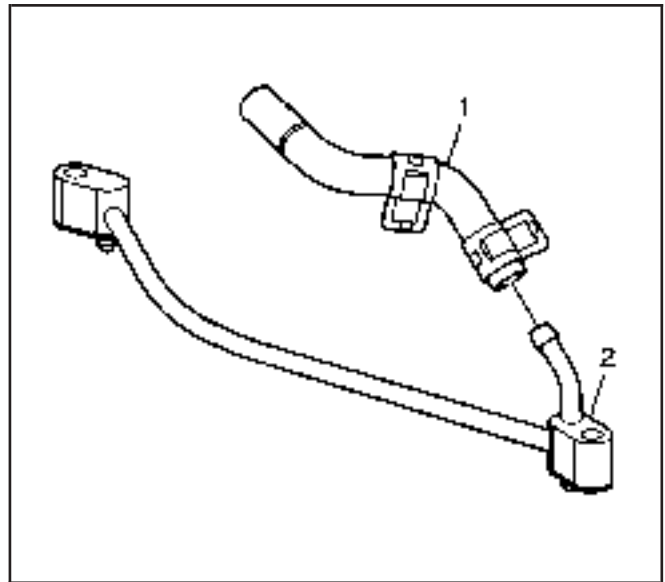
639609

4. Remove the gaskets from the pipe and covers.
5. Discard the gaskets.



64262

6. Remove the hose (1) from the pipe (2).

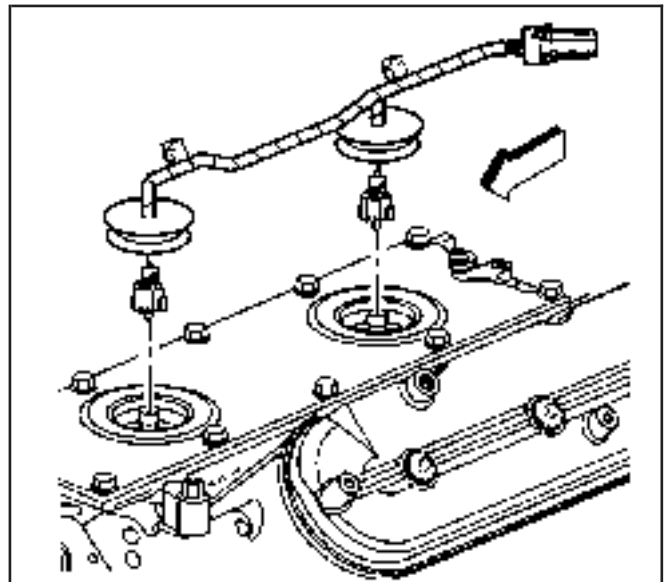


790766

Engine Valley Cover Removal

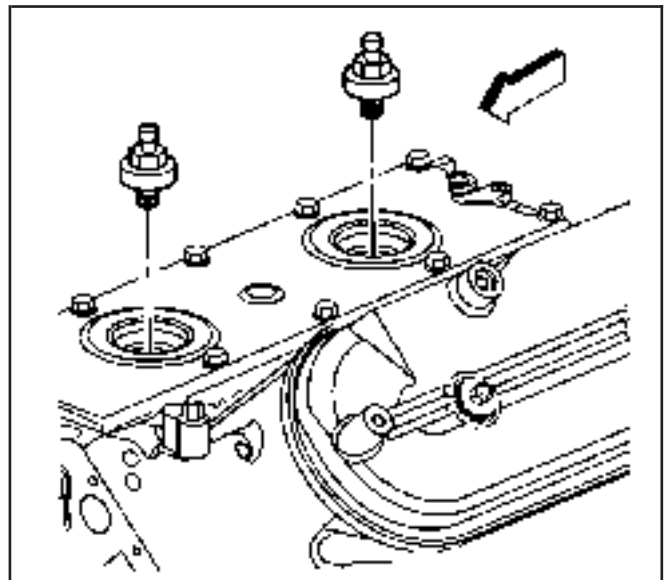
SIE-ID = 322858 LMD = 01-oct-1998

1. Remove the knock sensor wire harness.

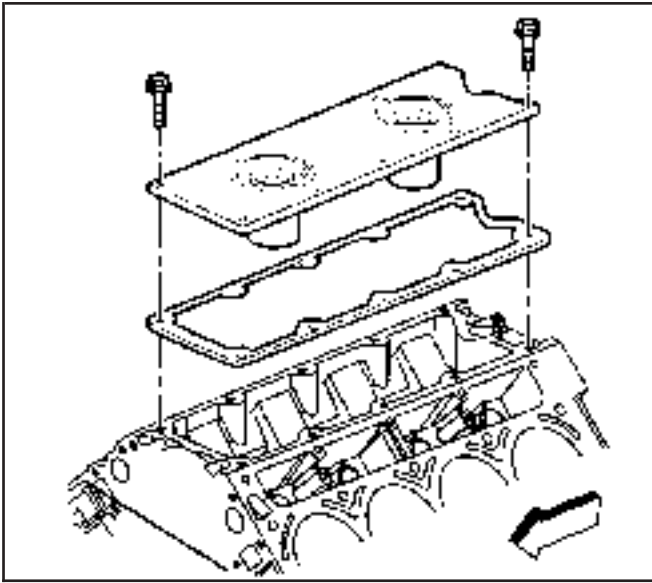


309859

2. Remove the knock sensors.

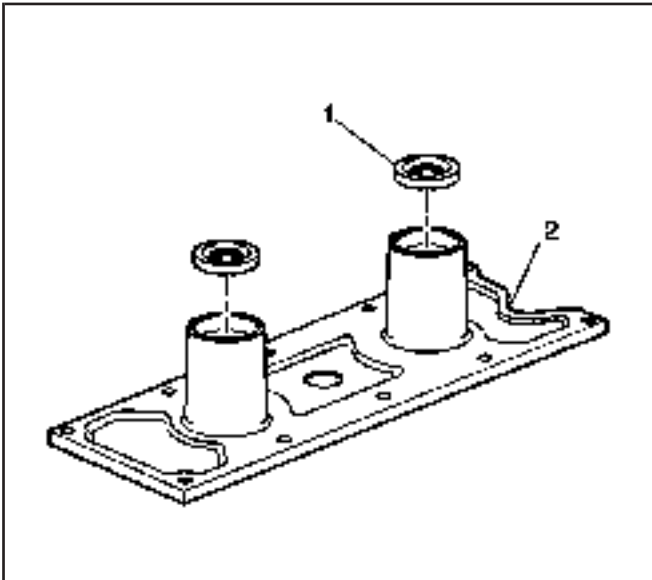


309864



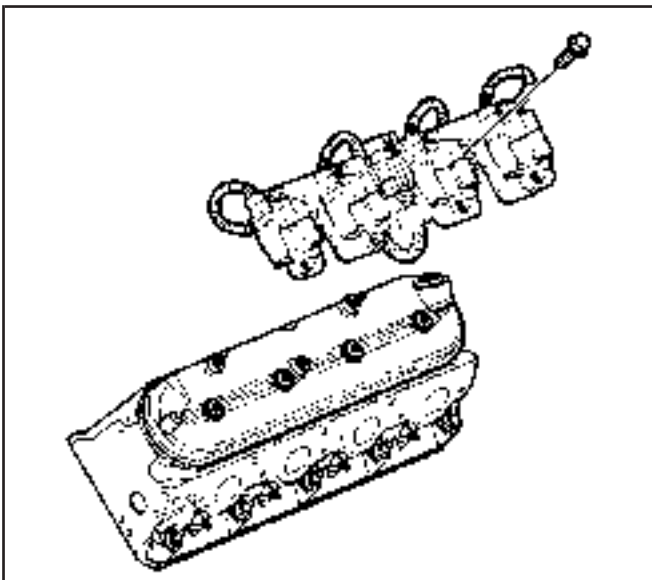
65048

3. Remove the valley cover bolts.
4. Remove the valley cover and gasket.
5. Discard the valley cover gasket.



490851

6. Remove the knock sensor oil seals (1) from the cover (2).



260083

Valve Rocker Arm Cover Removal - Left

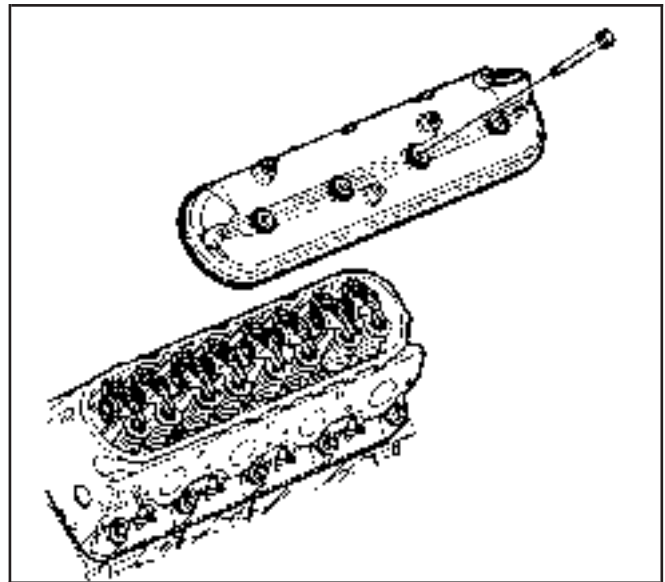
SIE-ID = 644003 LMD = 26-feb-2002

Important: Do not remove the ignition coils and bracket from the valve rocker arm cover unless required.

Do not remove the positive crankcase ventilation (PCV) valve grommet from the cover unless service is required.

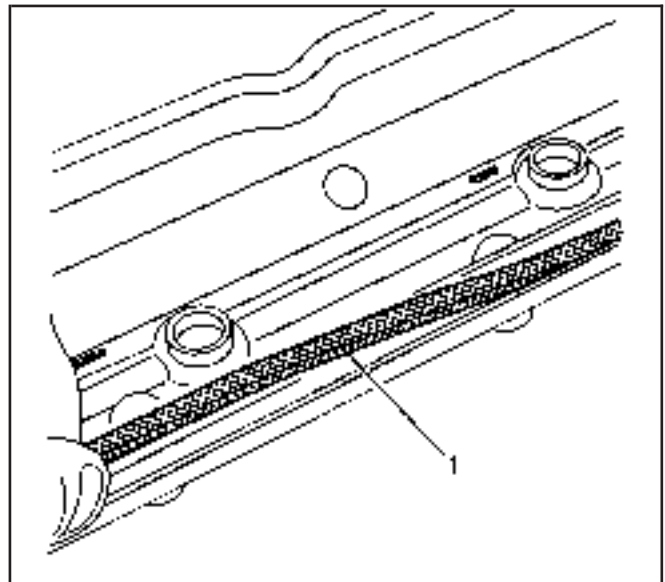
1. Remove the ignition coil bracket bolts from the rocker arm cover, if required.
2. Remove the ignition coil and bracket assembly from the cover.

3. Remove the valve rocker arm cover bolts.
4. Remove the valve rocker arm cover.



260085

5. Remove the gasket (1) from the cover.
 6. Discard the gasket.
- The bolt grommets may be used again if they are not damaged.



490696

Valve Rocker Arm Cover Removal - Right

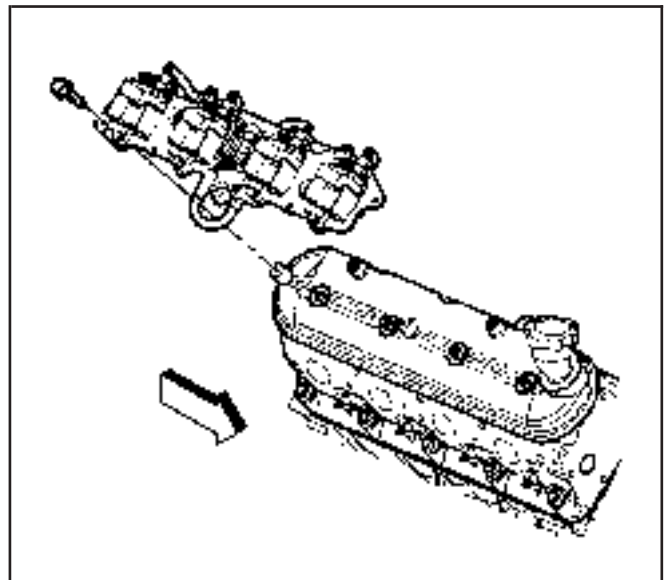
SIE-ID = 644011 LMD = 26-feb-2002

Important: Do not remove the ignition coils from the valve rocker arm cover unless required.

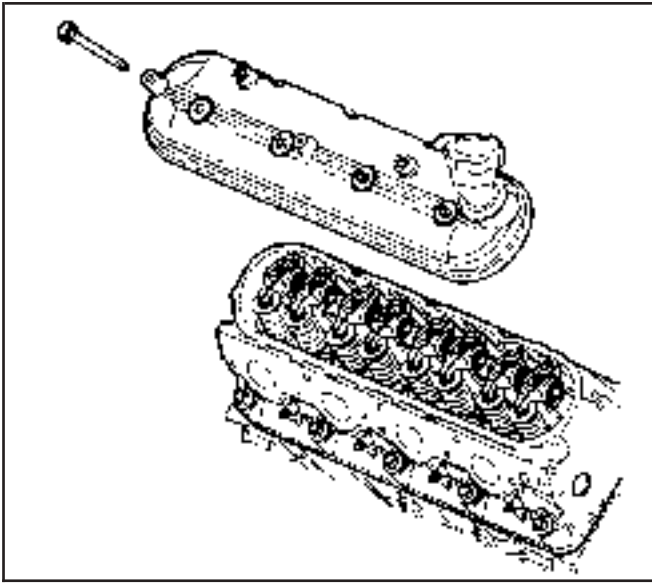
Do not remove the oil fill tube from the cover unless service is required.

If the oil fill tube has been removed from the cover, install a NEW tube during assembly.

1. Remove the ignition coil bracket bolts from the rocker arm cover, if required.
2. Remove the ignition coil and bracket assembly from the cover.

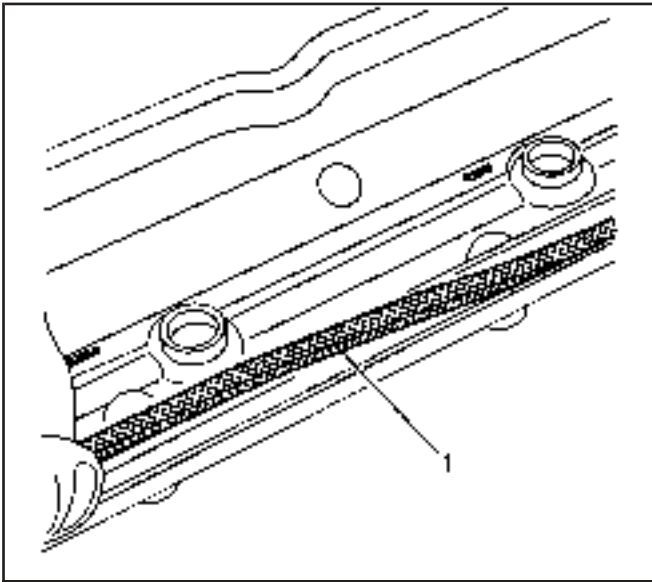


260090



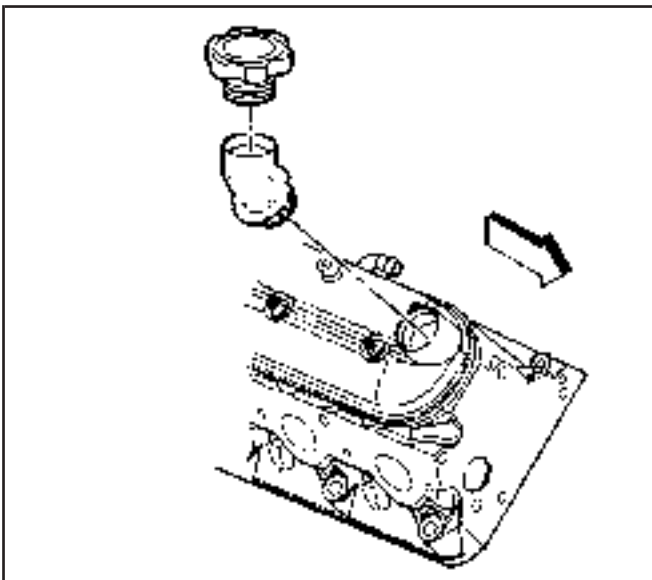
260084

3. Remove the valve rocker arm cover bolts.
4. Remove the valve rocker arm cover.



490696

5. Remove the gasket (1) from the cover.
6. Discard the gasket.
The bolt grommets may be used again if they are not damaged.



260110

7. Remove the oil fill cap from the oil fill tube.
8. Remove the oil fill tube, if required.
9. Discard the oil fill tube.

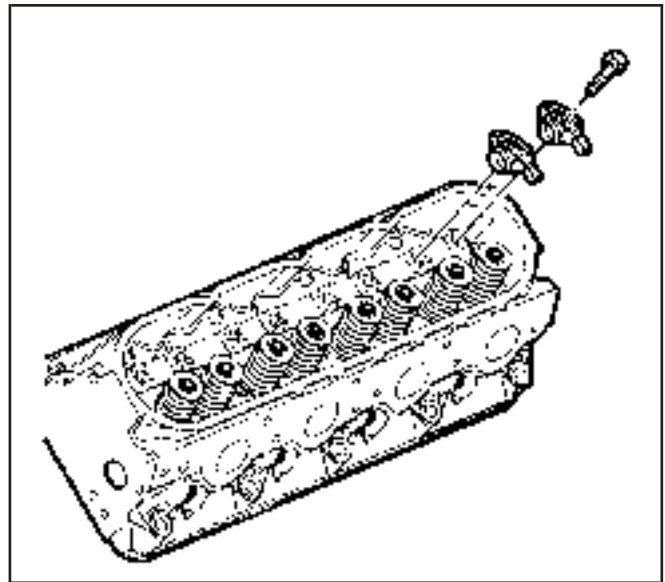
Valve Rocker Arm and Push Rod Removal

SIE-ID = 280805 LMD = 24-jul-1998

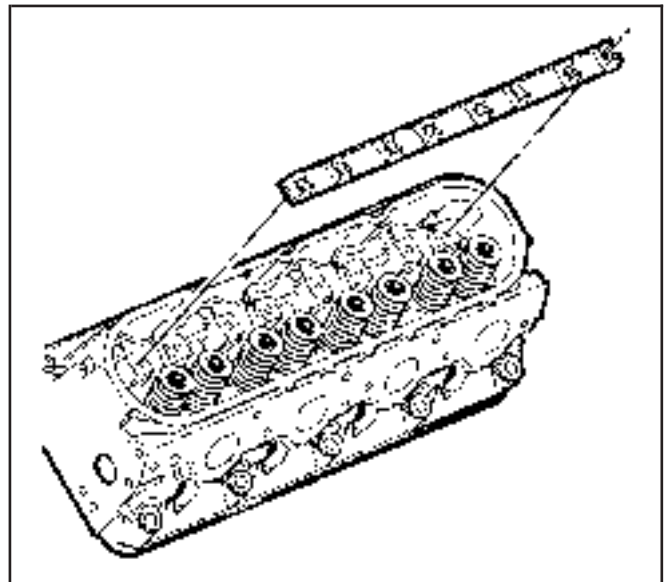
Important: Place valve rocker arms, valve pushrods, and pivot support, in a rack so that they can be installed in the same location from which they were removed.

1. Remove the valve rocker arm bolts.
2. Remove the valve rocker arms.

3. Remove the valve rocker arm pivot support.

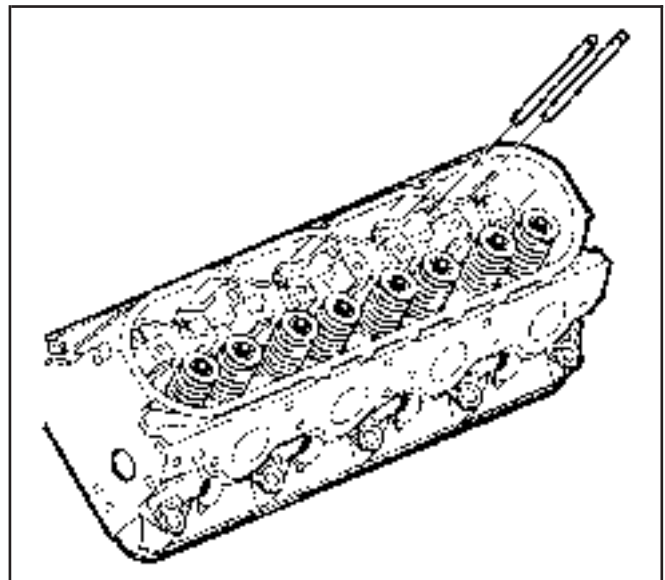


260140

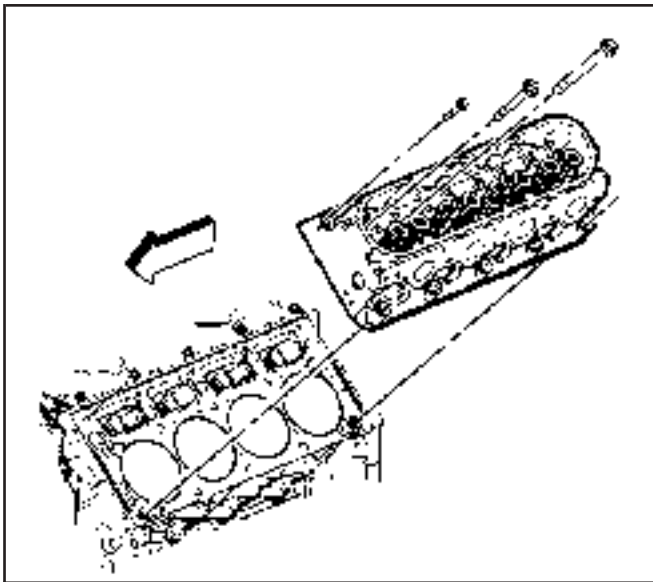


260141

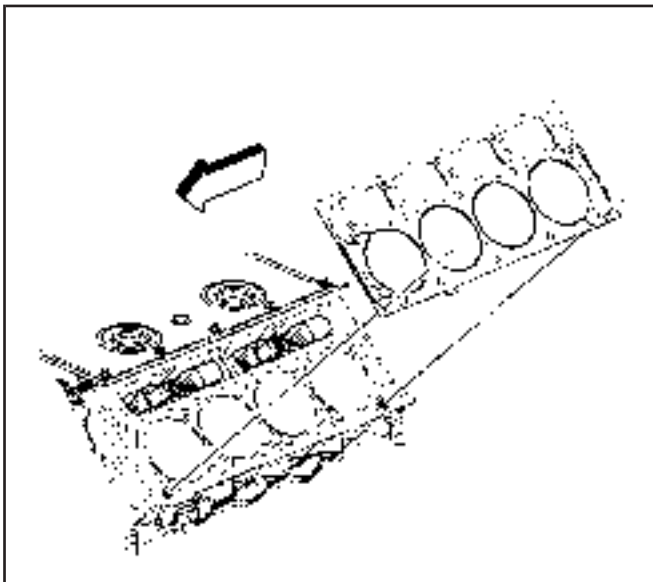
4. Remove the pushrods.



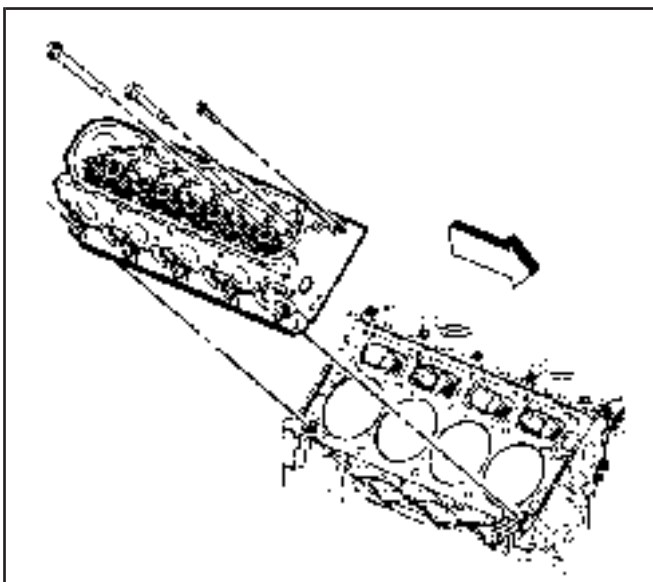
260142



260146



63169



260149

Cylinder Head Removal - Left

SIE-ID = 644020 LMD = 26-feb-2002

1. Remove the spark plugs from the cylinder head.

Important: The cylinder head bolts can NOT be used again. Install NEW cylinder head bolts during assembly.

2. Remove the cylinder head bolts.

Notice: SIO-ID = 13838 LMD = 11-oct-1995 After removal, place the cylinder head on two wood blocks to prevent damage.

3. Remove the cylinder head.

4. Remove the gasket.
5. Discard the gasket.
6. Discard the cylinder head bolts.

Cylinder Head Removal - Right

SIE-ID = 644023 LMD = 26-feb-2002

1. Remove the spark plugs from the cylinder head.

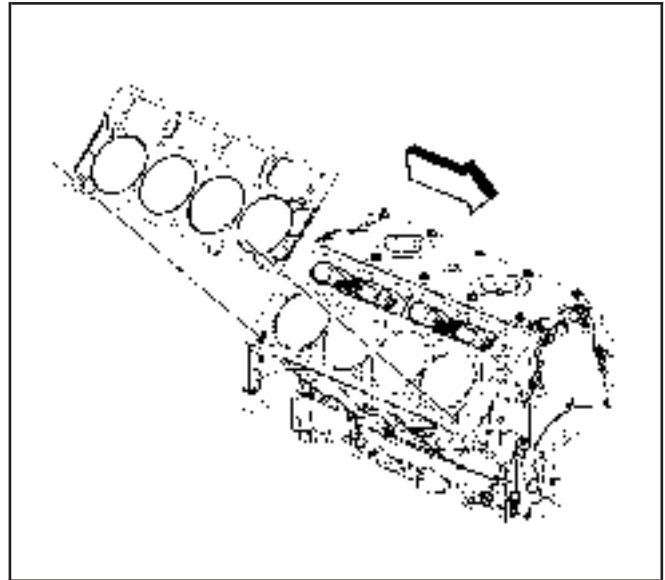
Important: The cylinder head bolts can NOT be used again. Install NEW cylinder head bolts during assembly.

2. Remove the cylinder head bolts.

Notice: SIO-ID = 13838 LMD = 11-oct-1995 After removal, place the cylinder head on two wood blocks to prevent damage.

3. Remove the cylinder head.

4. Remove the gasket.
5. Discard the gasket.
6. Discard the cylinder head bolts.



63170

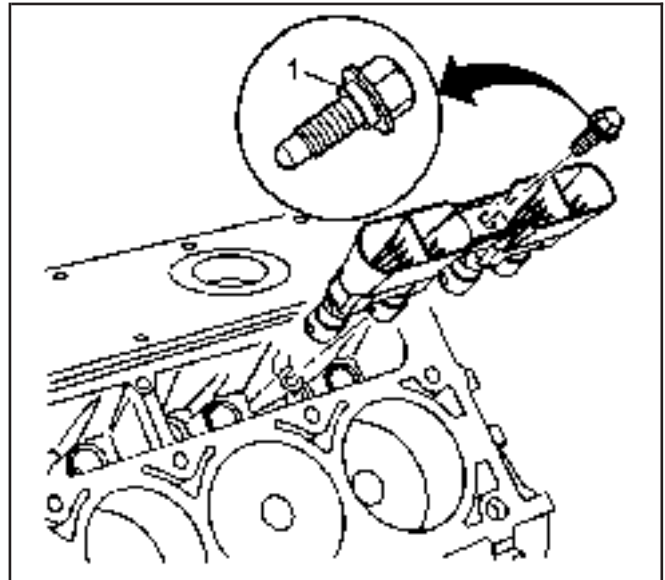
Valve Lifter Removal

SIE-ID = 773417 LMD = 15-jan-2001

Tools Required

J 3049-A Valve Lifter Remover

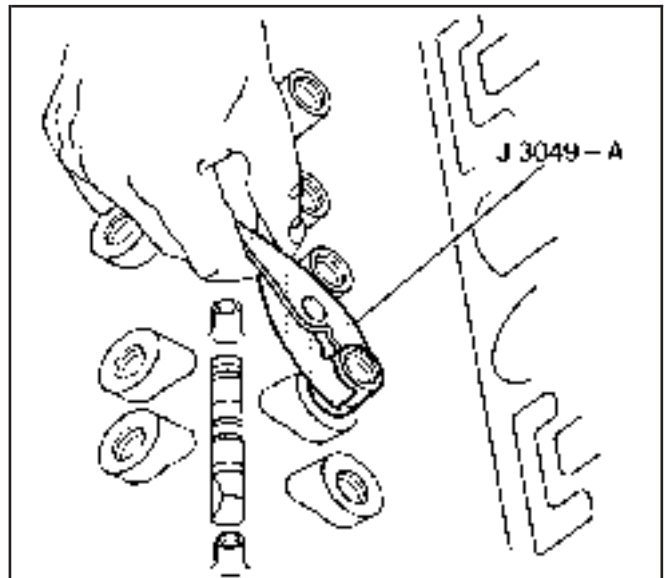
1. Remove the valve lifter guide bolts (1).
2. Remove the valve lifters and guide.



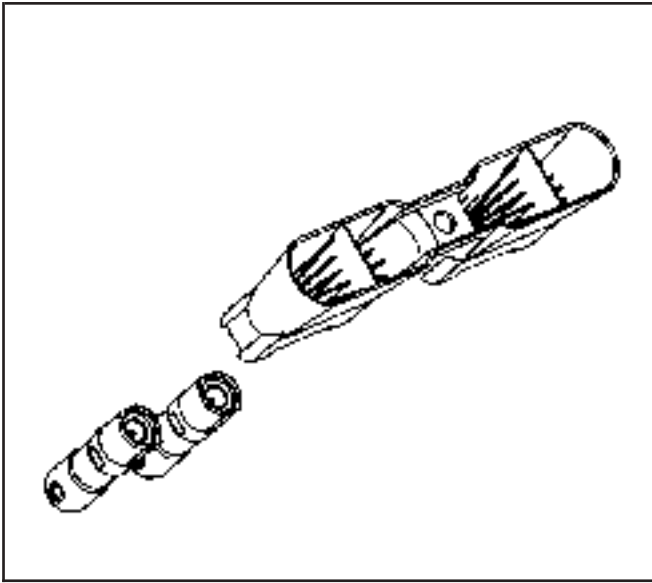
63230

Important: Some valve lifters may be stuck in their bores because of gum or varnish deposits.

3. Use the J 3049-A or equivalent in order to remove the valve lifters, if required.

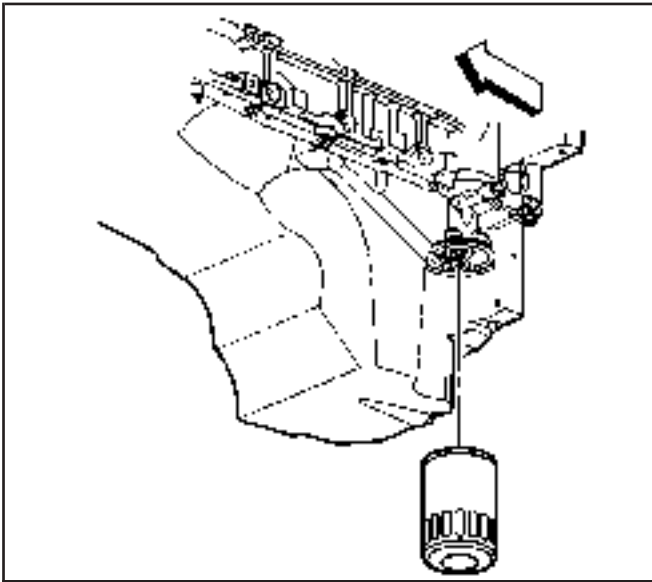


31350



63233

4. Remove the valve lifters from the guide.
5. Organize or mark the components so that they can be installed in the same location from which they were removed. Refer to *Separating Parts*.

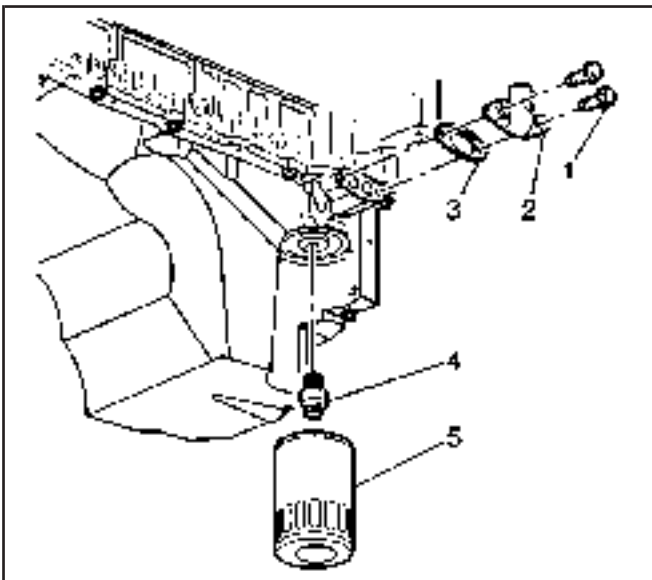


260117

Oil Filter, Adapter and Pan Cover Removal

SIE-ID = 280808 LMD = 27-dec-2000

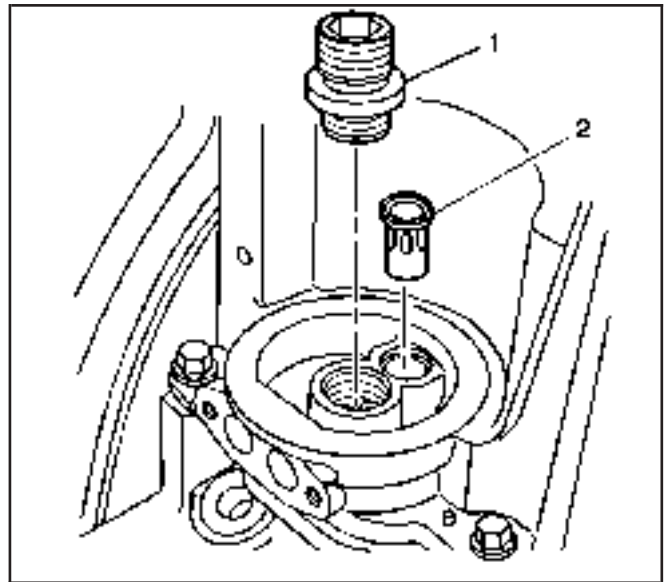
1. Remove the oil filter.



260125

2. Remove the oil pan cover (2), bolts (1), and gasket (3), if applicable.
3. Discard the gasket.

4. Remove the oil filter fitting (1) and bypass valve (2), if required.



490699

Oil Pan Removal

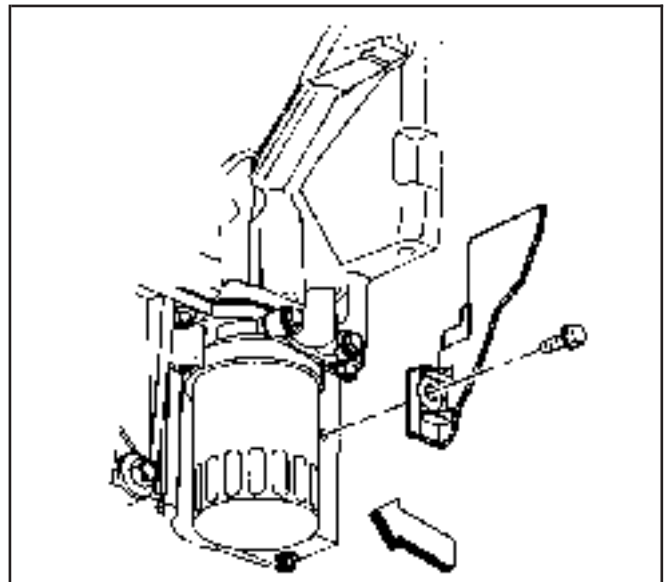
SIE-ID = 280810 LMD = 26-feb-2002

Important: The original oil pan gasket is retained and aligned to the oil pan by rivets. When installing a new gasket, it is not necessary to install new oil pan gasket rivets.

DO NOT use the oil pan gasket again. When installing the oil pan, install a NEW oil pan gasket.

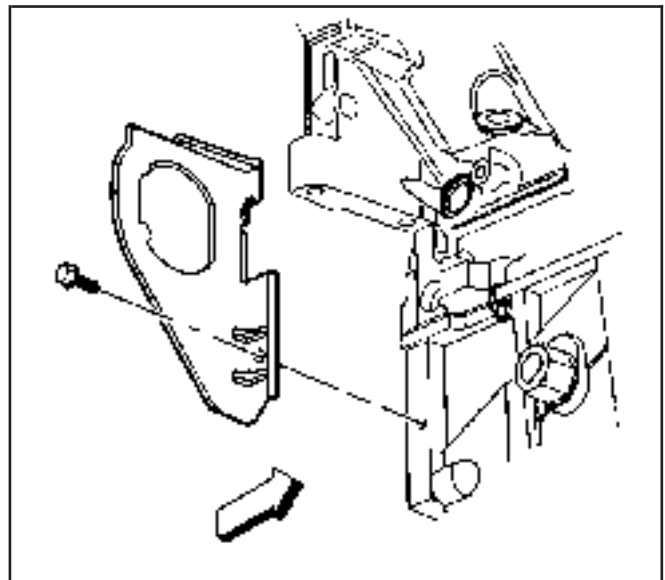
It is not necessary to remove the oil level sensor prior to oil pan removal. Remove the oil level sensor if service is required.

1. Remove the left closeout cover and bolt.

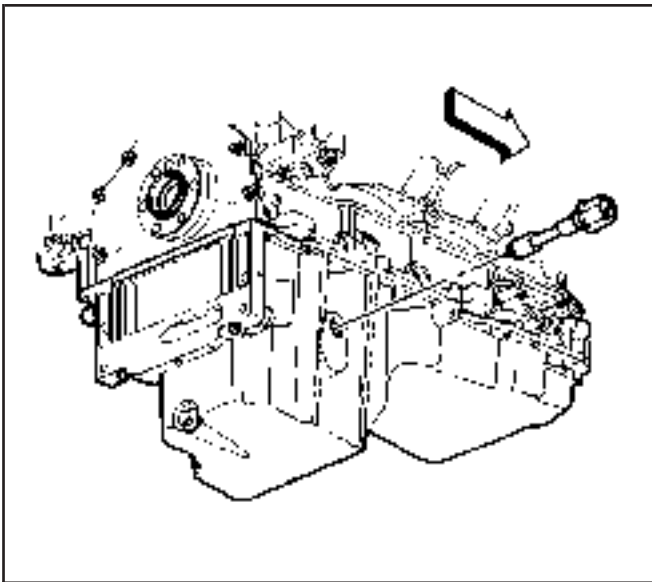


178477

2. Remove the right closeout cover and bolt.

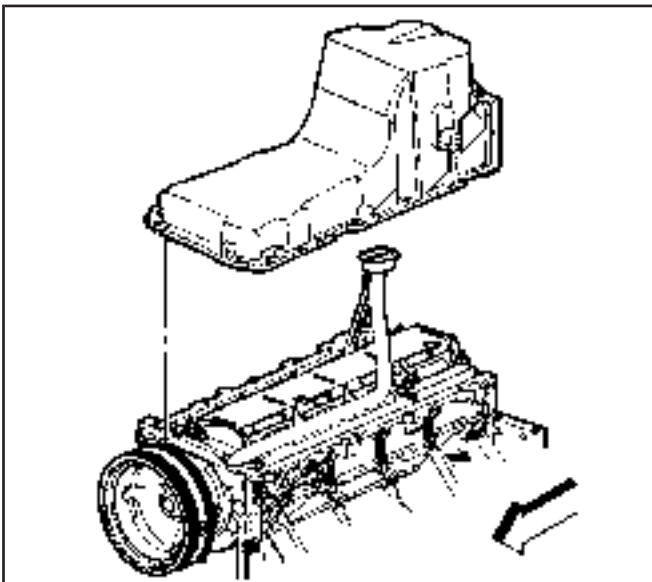


178480



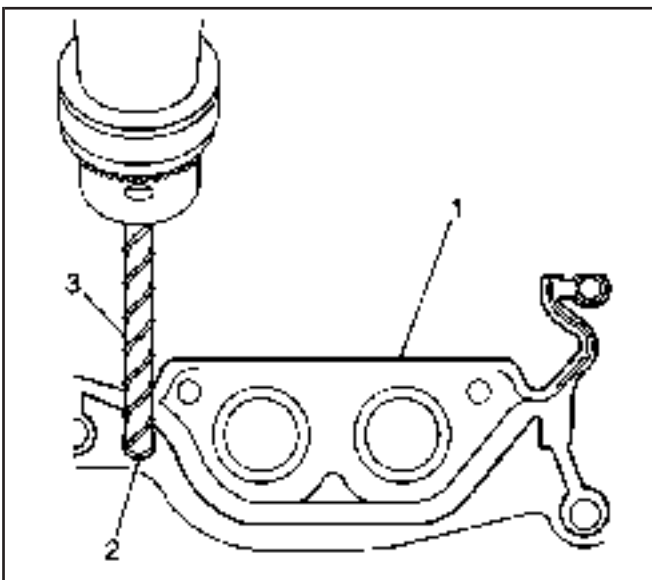
260123

3. Remove the oil level sensor from the oil pan, if required.



260108

4. Remove the oil pan bolts.
5. Remove the oil pan.



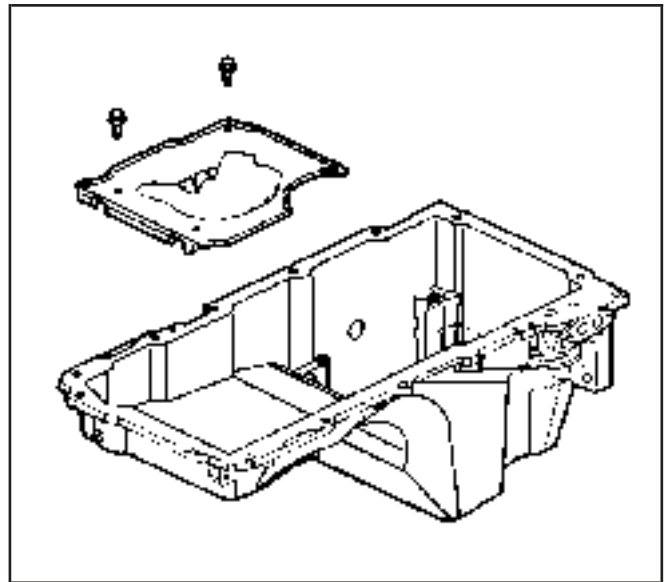
384699

Important: DO NOT allow foreign material to enter the oil passages of the oil pan, cap or cover the openings as required.

Use care not to gouge, score, or damage the oil pan sealing surface.

6. Drill (3) out the oil pan gasket retaining rivets (2), if required.
7. Remove the gasket (1) from the pan.
8. Discard the gasket and rivets.

9. Remove the oil pan baffle bolts and baffle, if required.



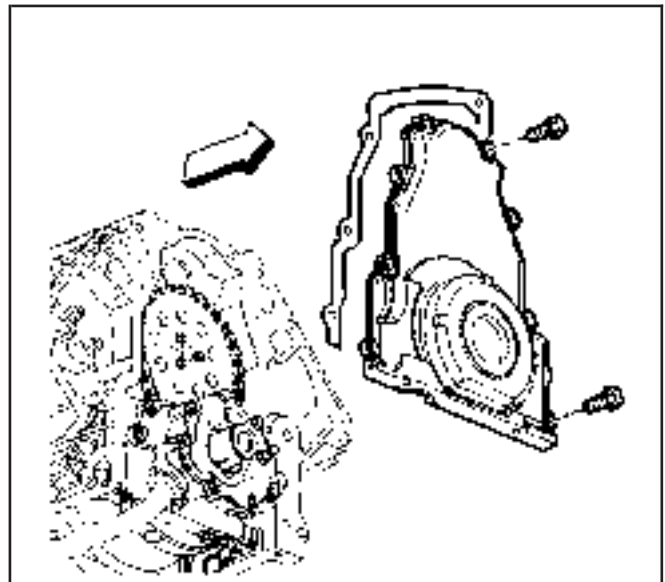
260180

Engine Front Cover Removal

SIE-ID = 73699 LMD = 24-jul-1998

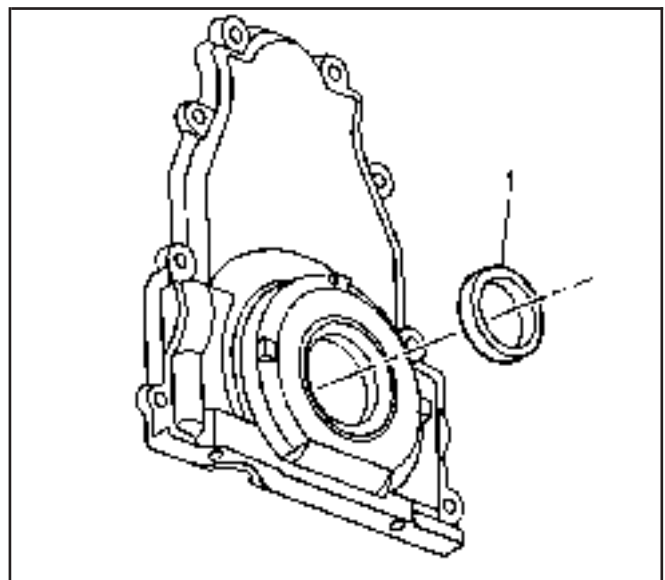
SIO-ID = 70612 LMD = 01-oct-1998

1. Remove the front cover bolts.
2. Remove the front cover and gasket.
3. Discard the front cover gasket.

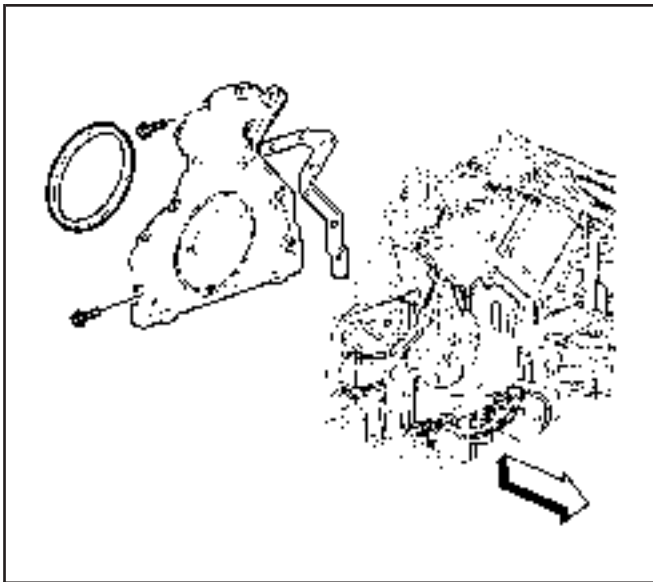


64278

4. Remove the crankshaft front oil seal (1) from the cover.



490689



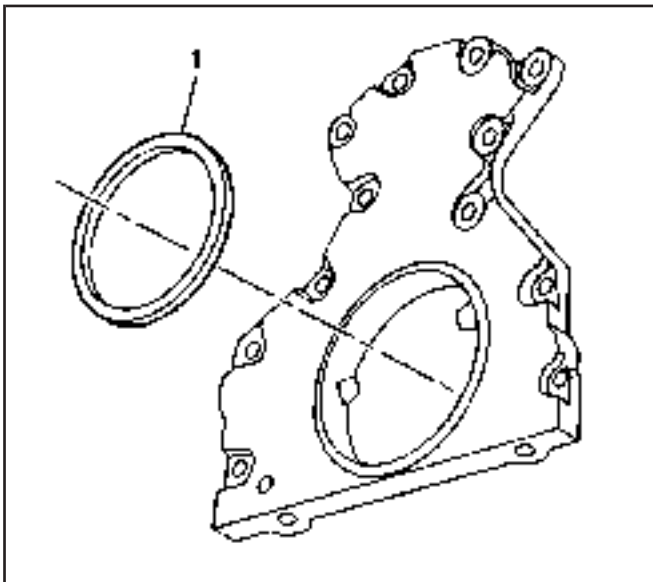
64282

Engine Rear Cover Removal

SIE-ID = 73700 LMD = 24-jul-1998

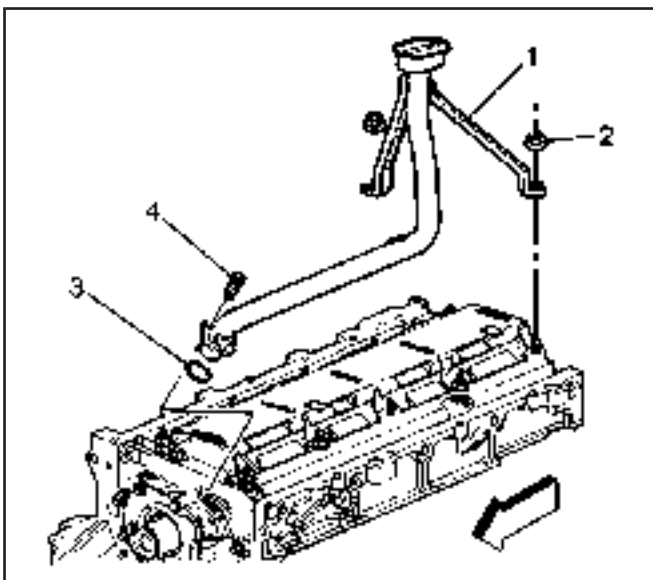
SIO-ID = 70614 LMD = 01-oct-1998

1. Remove the rear cover bolts.
2. Remove the rear cover and gasket.
3. Discard the rear cover gasket.



490692

4. Remove the crankshaft rear oil seal (1) from the cover.



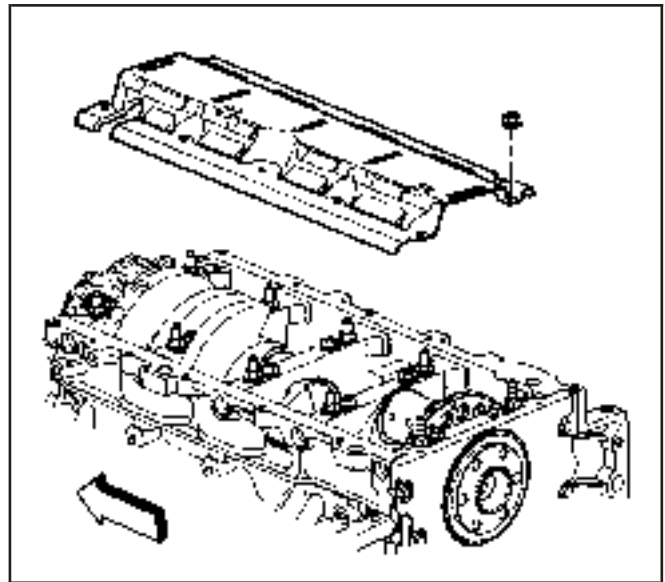
260109

Oil Pump, Pump Screen and Deflector Removal

SIE-ID = 280811 LMD = 24-jul-1998

1. Remove the oil pump screen bolt (4) and nuts (2).
2. Remove the oil pump screen (1) with O-ring seal (3).
3. Remove the O-ring seal from the pump screen.
4. Discard the O-ring seal.

5. Remove the remaining crankshaft oil deflector nuts.
6. Remove the crankshaft oil deflector.

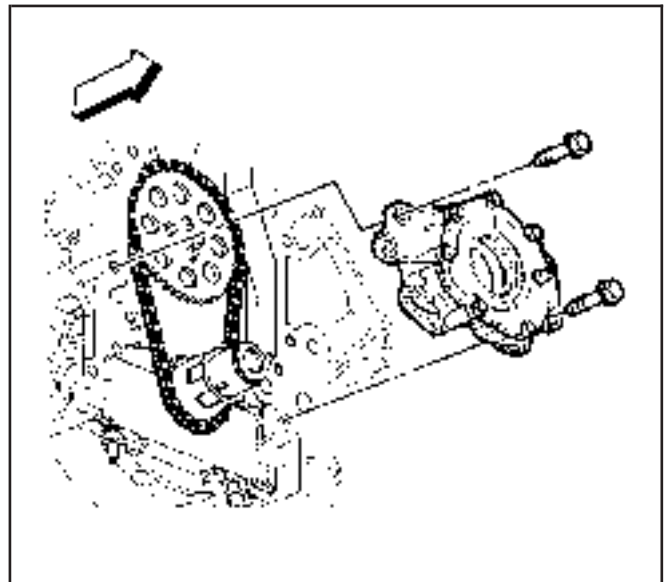


260099

7. Remove the oil pump bolts.

Important: Do not allow dirt or debris to enter the oil pump assembly, cap ends as necessary.

8. Remove the oil pump.



64281

Timing Chain and Sprockets Removal

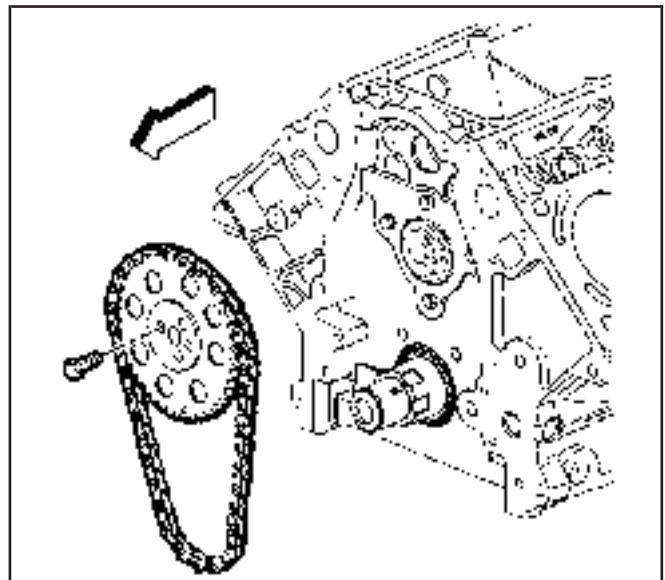
SIE-ID = 73701 LMD = 01-mar-2002

Tools Required

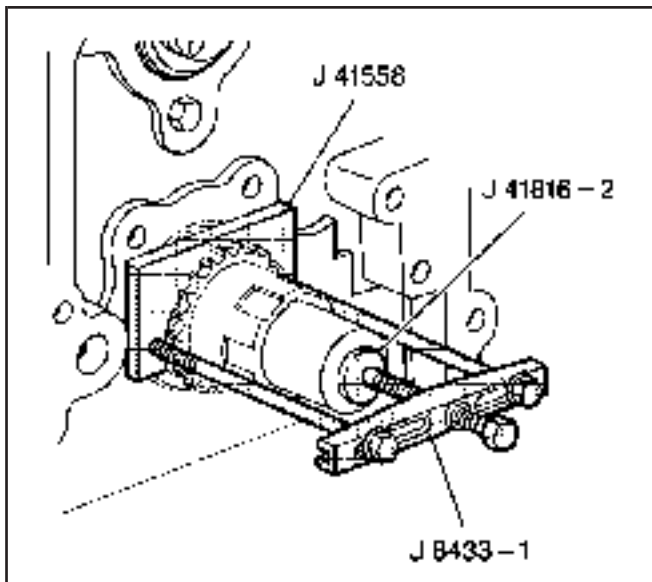
- J 8433-1 Two Jaw Puller
- J 41558 Crankshaft Sprocket Remover
- J 41816-2 Crankshaft End Protector

Notice: SIO-ID = 14030 LMD = 12-oct-1995 Do not turn the crankshaft assembly after the timing chain has been removed in order to prevent damage to the piston assemblies or the valves.

1. Remove the camshaft sprocket bolts.
2. Remove the camshaft sprocket and timing chain.

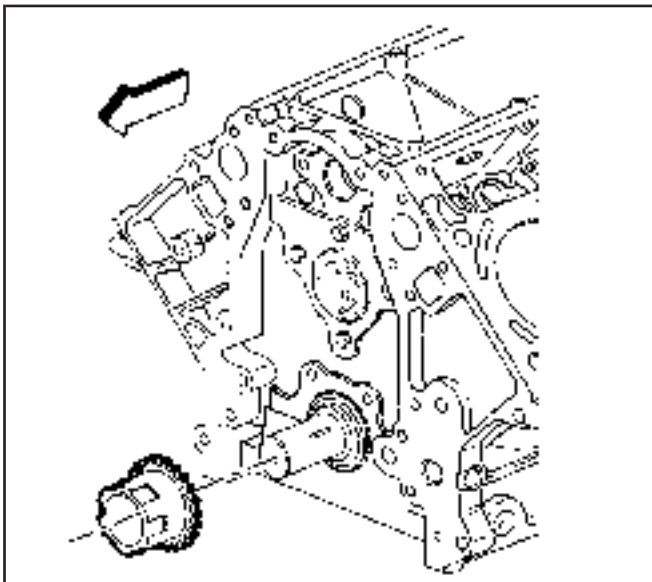


63263



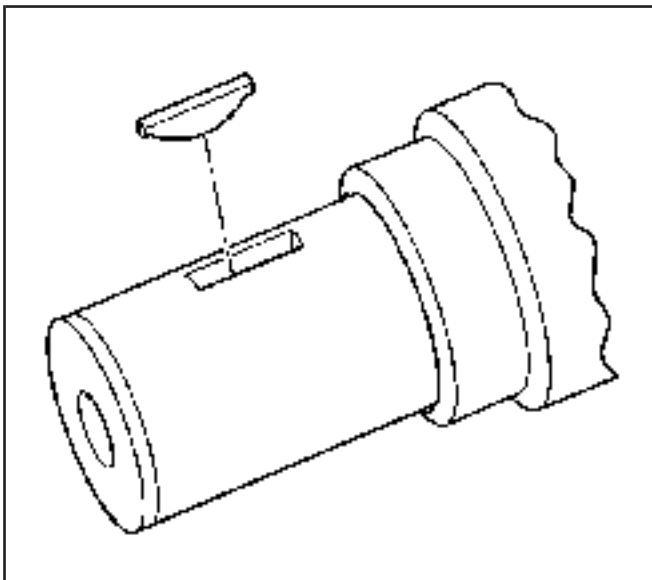
63189

3. Use the *J 8433-1*, the *J 41816-2*, and the *J 41558* in order to remove the crankshaft sprocket.



156150

4. Remove the crankshaft sprocket.



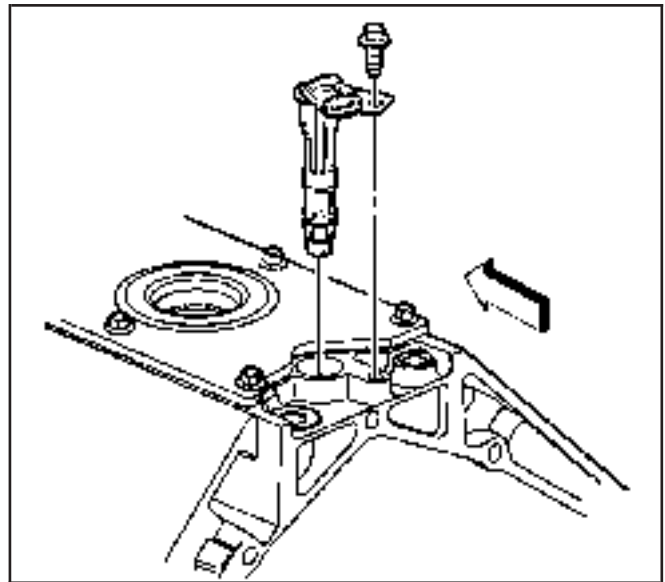
156149

5. Remove the crankshaft sprocket key, if required.

Camshaft Removal

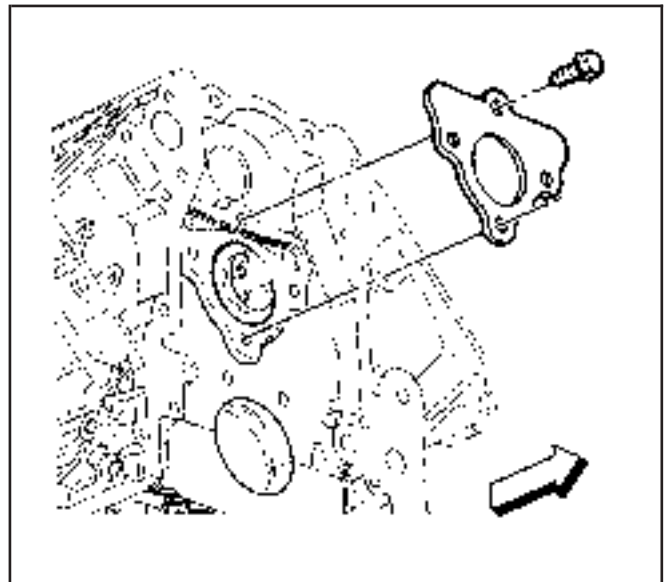
SIE-ID = 73702 LMD = 23-mar-2001

1. Remove the camshaft sensor bolt and the sensor.



260128

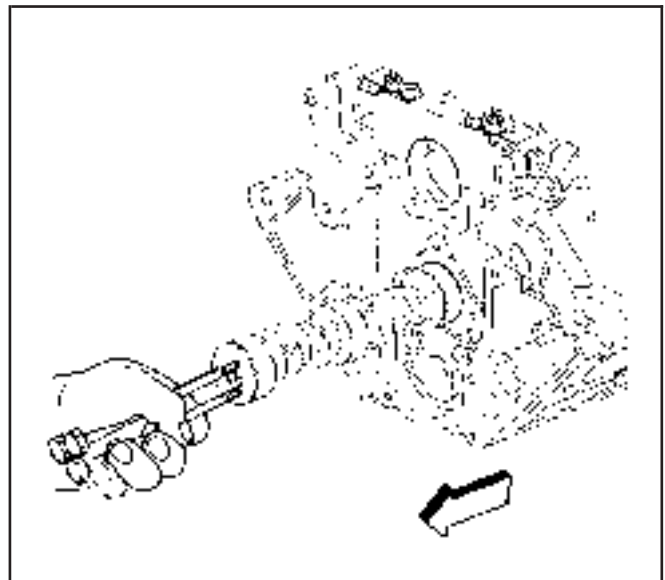
2. Remove the camshaft retainer bolts and the retainer.



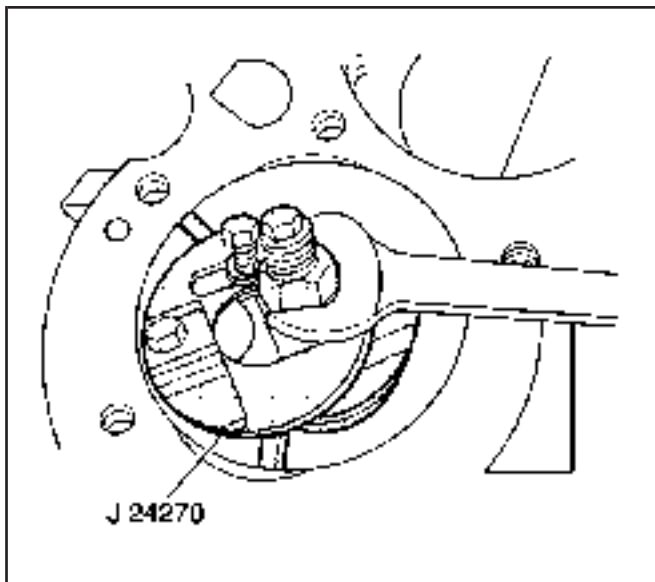
63211

Notice: SIO-ID = 13833 LMD = 03-feb-1998 All camshaft journals are the same diameter, so care must be used in removing or installing the camshaft to avoid damage to the camshaft bearings.

3. Remove the camshaft.
 - 3.1. Install the 3 M8-1.25 x 100 mm bolts in the camshaft front bolt holes.
 - 3.2. Using the bolts as a handle, carefully rotate and pull the camshaft out of the engine block.
 - 3.3. Remove the bolts from the front of the camshaft.



63212



11497

Piston, Connecting Rod, and Bearing Removal

SIE-ID = 773419 LMD = 15-jan-2001

Tools Required

- J 24270 Cylinder Bore Ridge Reamer
- J 41556 Connecting Rod Guide

Important: The connecting rods and the bearing caps are NOT interchangeable.

1. Use the J 24270 in order to remove the cylinder bore ring ridge, if required.
 - 1.1. Turn the crankshaft until the piston is at the bottom of the stroke.
 - 1.2. Place a cloth on top of the piston.
 - 1.3. Use the J 24270 or equivalent in order to remove a cylinder ring ridge.
 - 1.4. Turn the crankshaft so the piston is at the top of the stroke.
 - 1.5. Remove the cloth.
 - 1.6. Remove the cutting debris from the cylinder and piston.

Important: Using a paint stick or etching tool, place matchmarks or numbers on the connecting rods and the connecting rod caps. The connecting rods and caps MUST be assembled to their original position and direction.

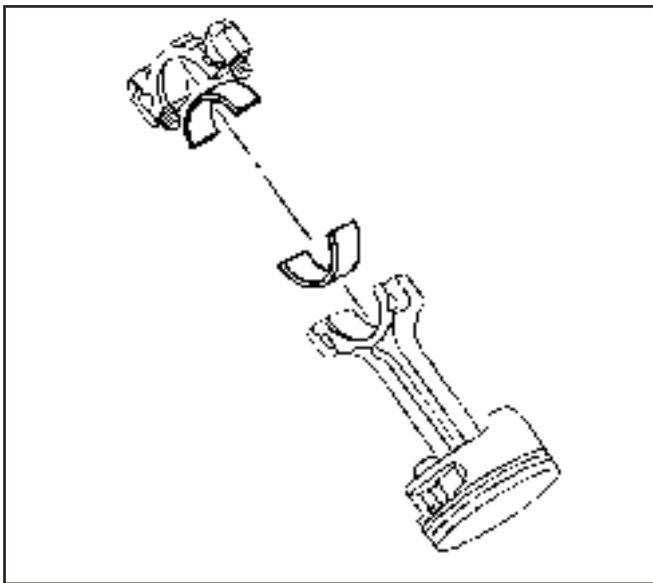
A stamping mark on the side of the connecting rod at the crank journal may effect component geometry.

Mark the top of the piston to the specific cylinder bore.

2. Remove the connecting rod bolts.

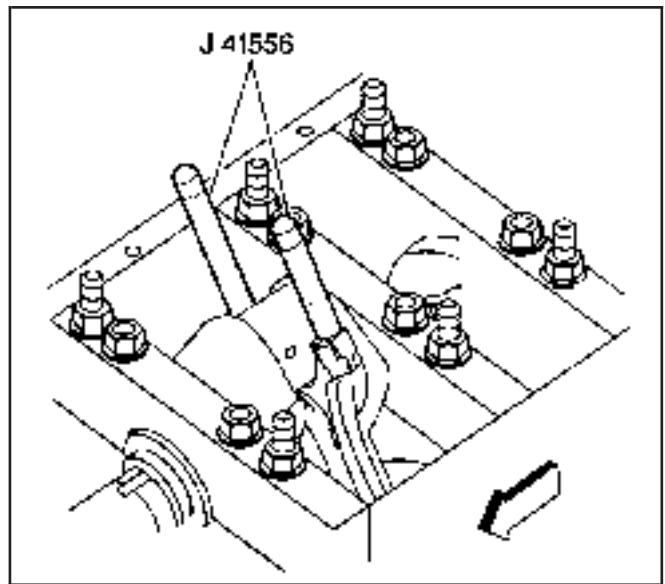
Important: Mark, sort, or organize the connecting rod bearings so they may be installed to their original position and location.

3. Remove the connecting rod cap. Refer to *Separating Parts*.



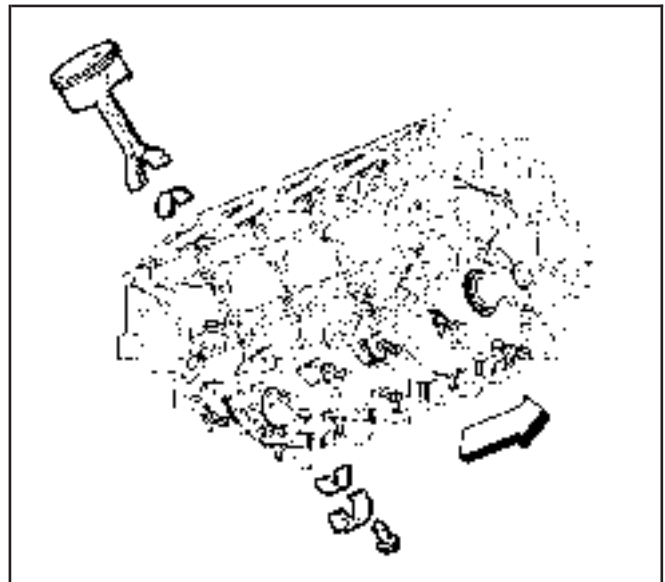
53223

4. Install the *J 41556* to the connecting rod.



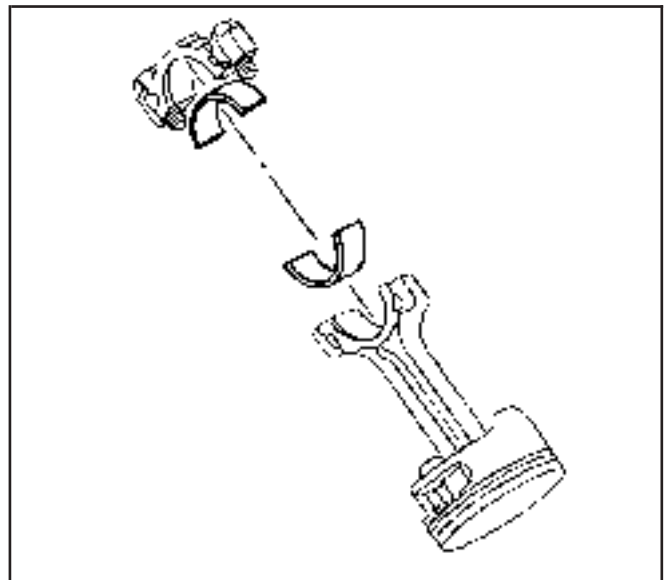
63186

5. Use a hammer and tap lightly on the end of the *J 41556* in order to remove the piston and connecting rod assembly from the cylinder bore.

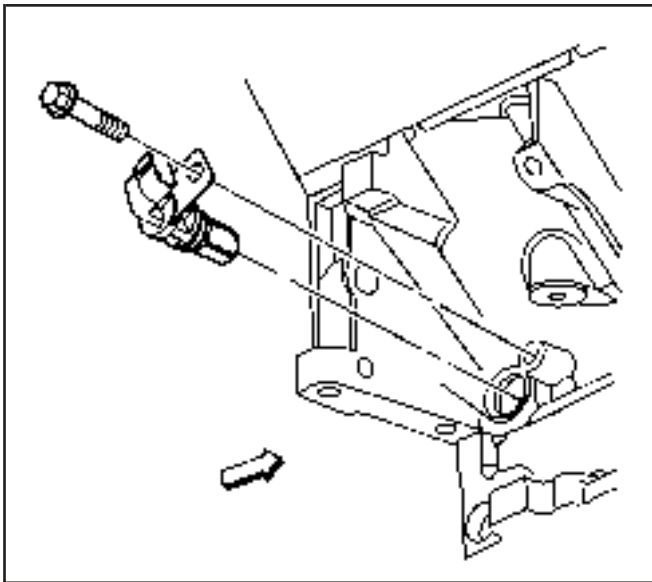


64285

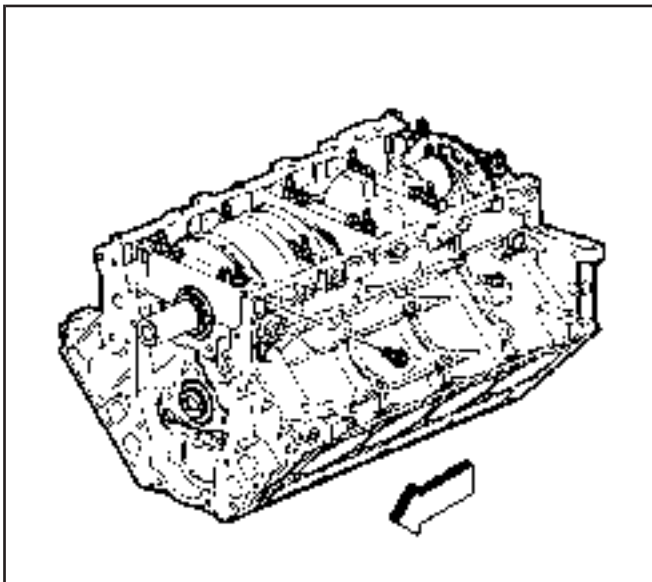
6. Upon removal of the piston and connecting rod assembly, assemble the connecting rod cap and bolts onto the matching connecting rod.



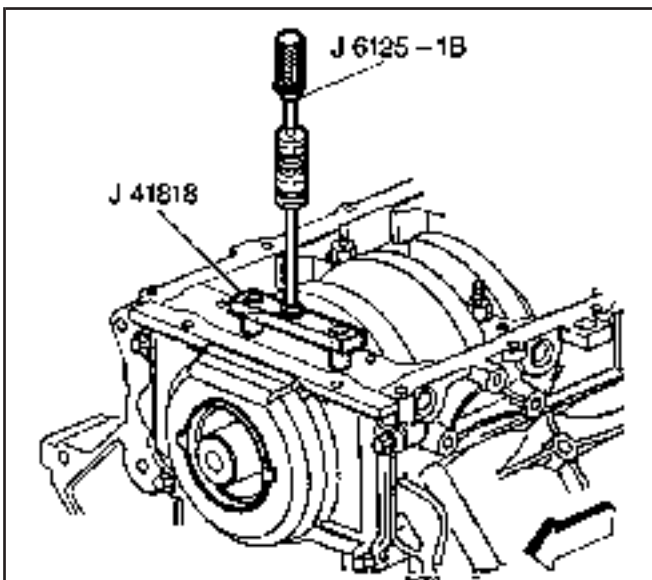
53223



55322



156155



63188

Crankshaft and Bearings Removal

SIE-ID = 741702 LMD = 18-mar-2002

Tools Required

- J 6125-1B Slide Hammer
- J 41818 Crankshaft Bearing Cap Remover

Important: The crankshaft bearing caps are machined with the engine block for the proper clearances. Mark or identify each crankshaft bearing cap location and direction before removal. The crankshaft bearing caps **MUST** be installed to their original position and direction.

Do not use the bearing cap M8 side bolts again.

Remove the bearing cap M8 side bolts prior to cap removal.

1. Remove the crankshaft position sensor bolt.
2. Remove the crankshaft position sensor.
3. Remove the crankshaft bearing cap M8 side bolts.
4. Remove the bearing cap M10 bolts and bolt/studs. Note the M10 bolt/stud locations.

Notice: Refer to *Fastener Notice* in Cautions and Notices.

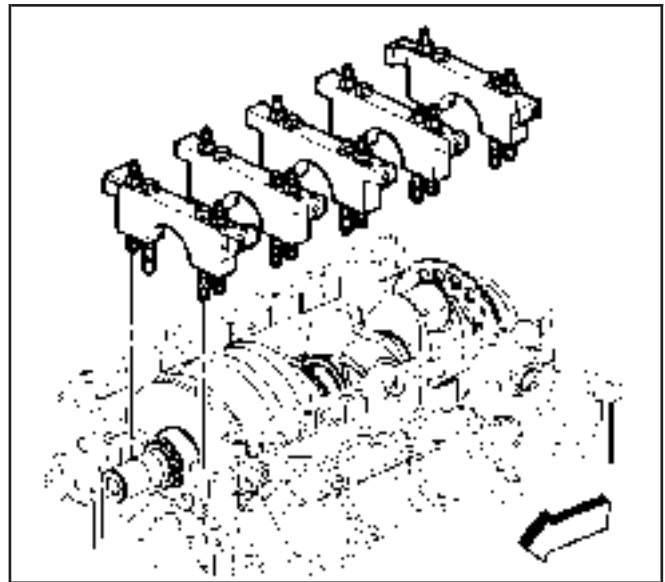
5. Install the J 41818.

Tighten

Tighten the J 41818 bolts to 11 N·m (100 lb in).

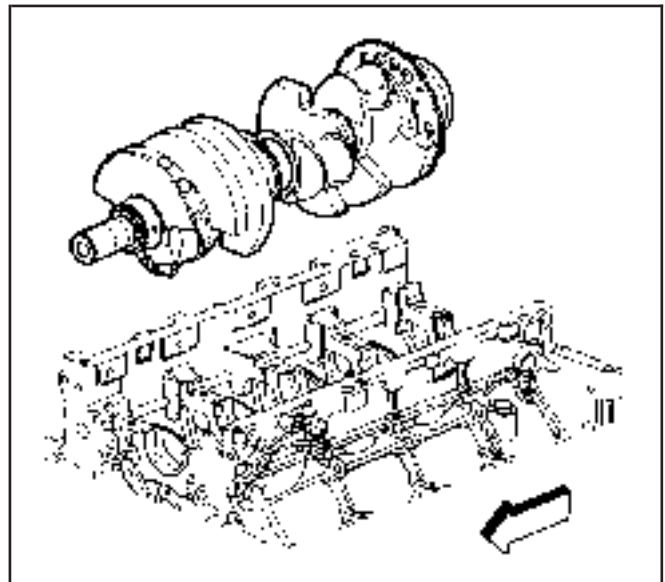
6. Install the J 6125-1B to the J 41818 in order to remove the crankshaft bearing caps.

7. Remove the bearing caps.



156152

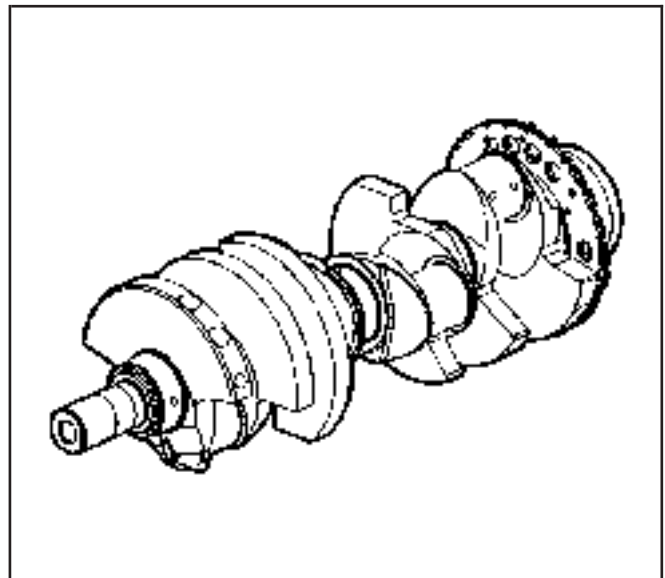
8. Remove the crankshaft.



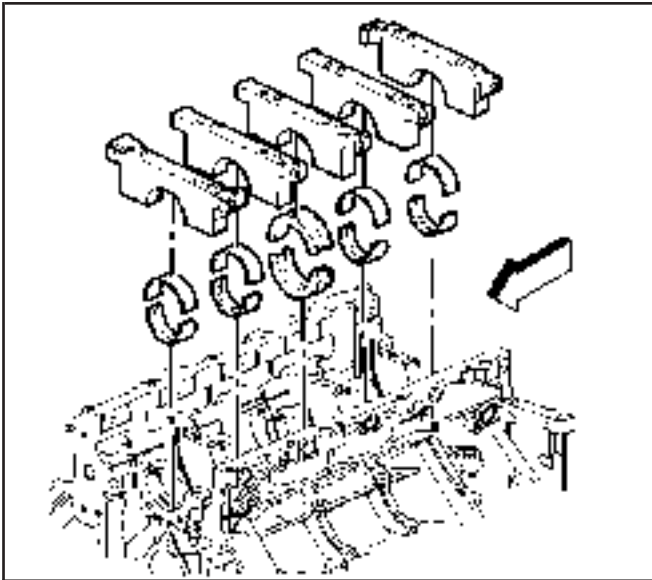
156151

Important: Use care when handling the crankshaft. Avoid damage to the crankshaft position sensor reluctor ring teeth. Nicks, burrs or other damage to the teeth may effect On-Board Diagnostics (OBD) II system performance.

9. Lay the crankshaft onto two wooden V blocks or other protective surface.

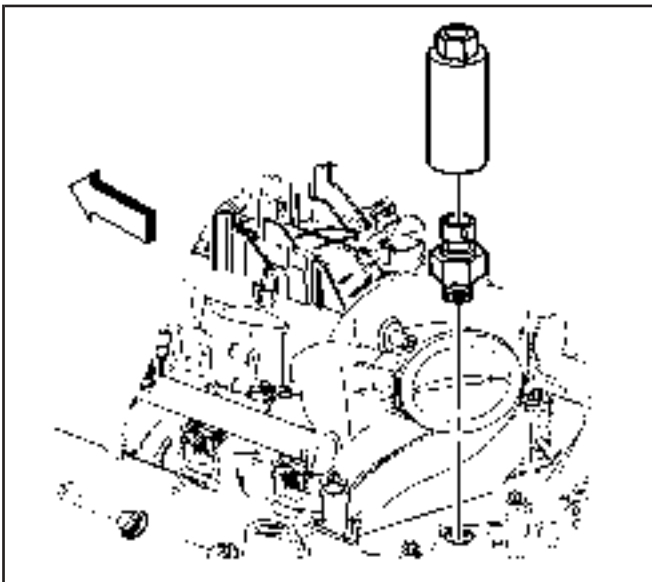


156153



64293

10. Remove the crankshaft bearings from the bearing caps and the engine block.
11. Mark, sort, or organize the crankshaft bearings so they may be installed to their original position and location. Refer to *Separating Parts*.



823316

Engine Block Plug Removal

SIE-ID = 823813 LMD = 26-feb-2002

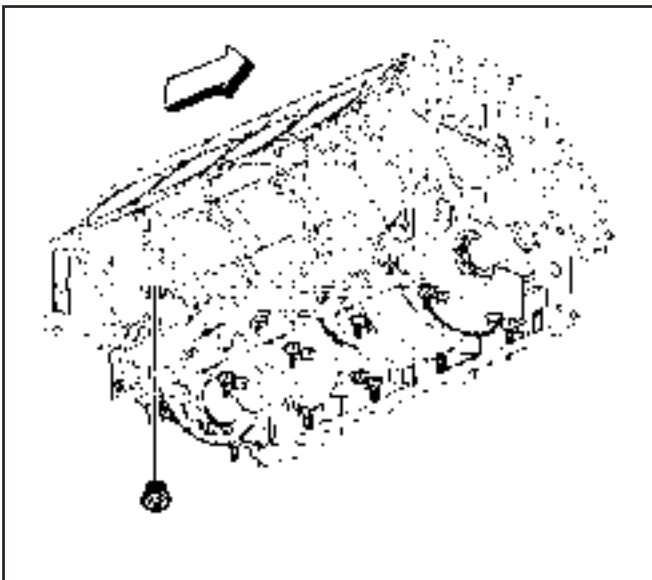
Tools Required

J 41712 Oil Pressure Switch Socket

Important: Do not remove the engine block front oil gallery plug unless service is required.

If the front oil gallery plug is removed for service, a NEW oil gallery plug must be installed.

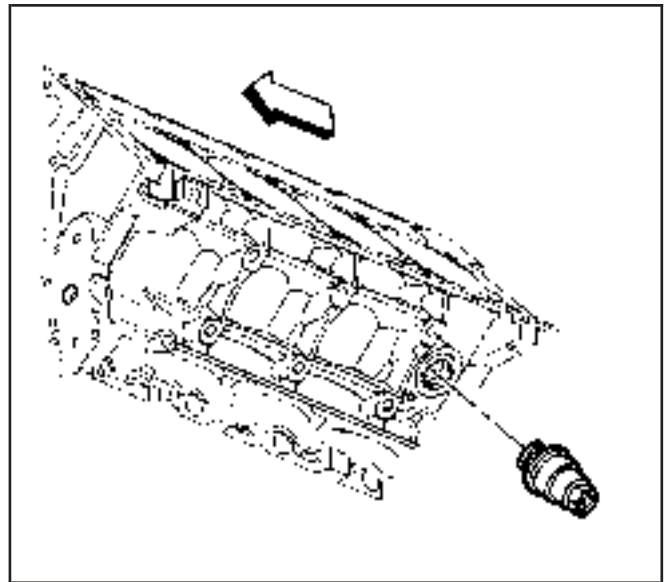
1. Remove the oil pressure sensor, if not previously removed, using the *J 41712* or equivalent.



63164

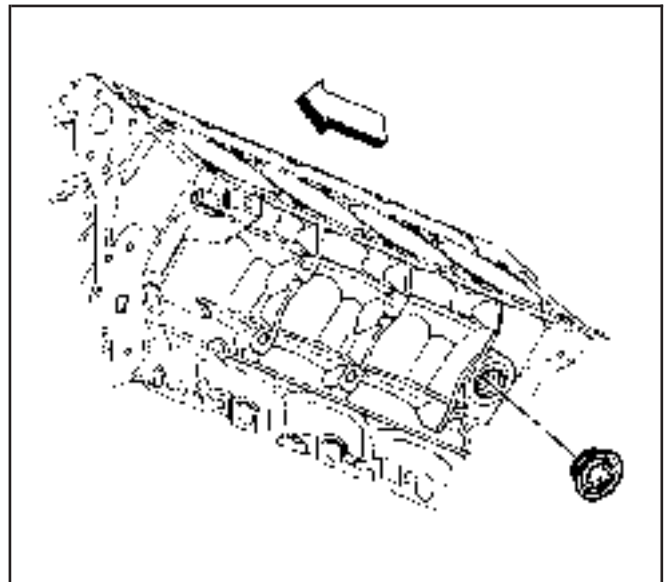
2. Remove the engine block right rear coolant plug.

- 3. Remove the engine block coolant heater, if applicable.



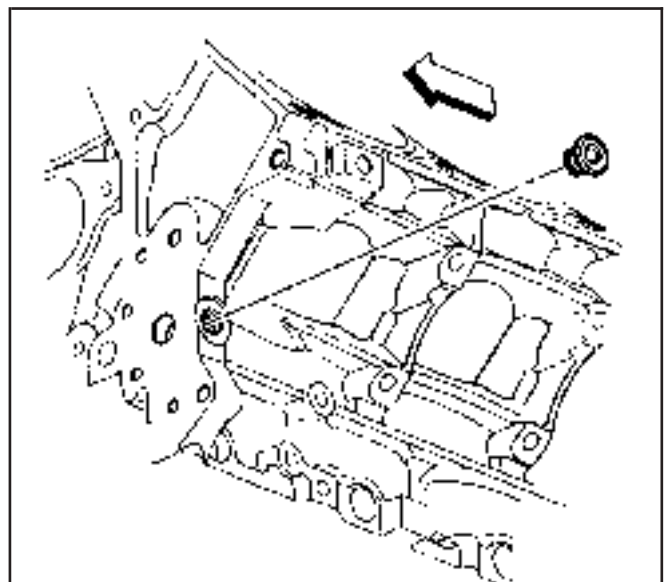
260137

- 4. Remove the engine block left rear coolant plug, if applicable.

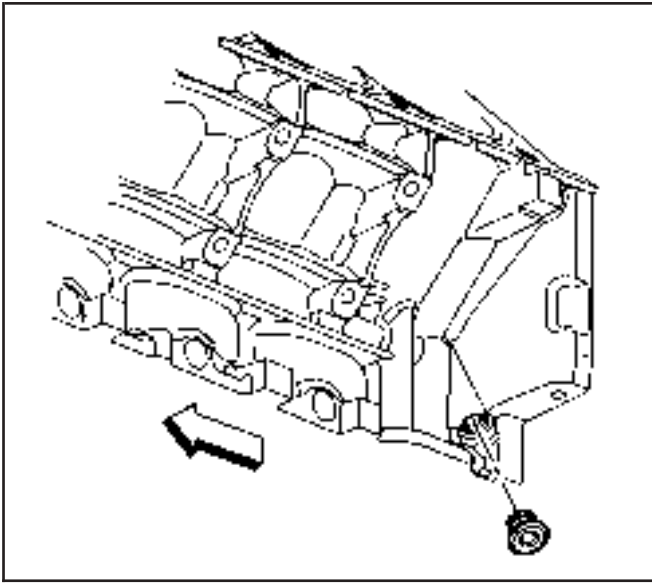


260138

- 5. Remove the engine block left front oil gallery plug.

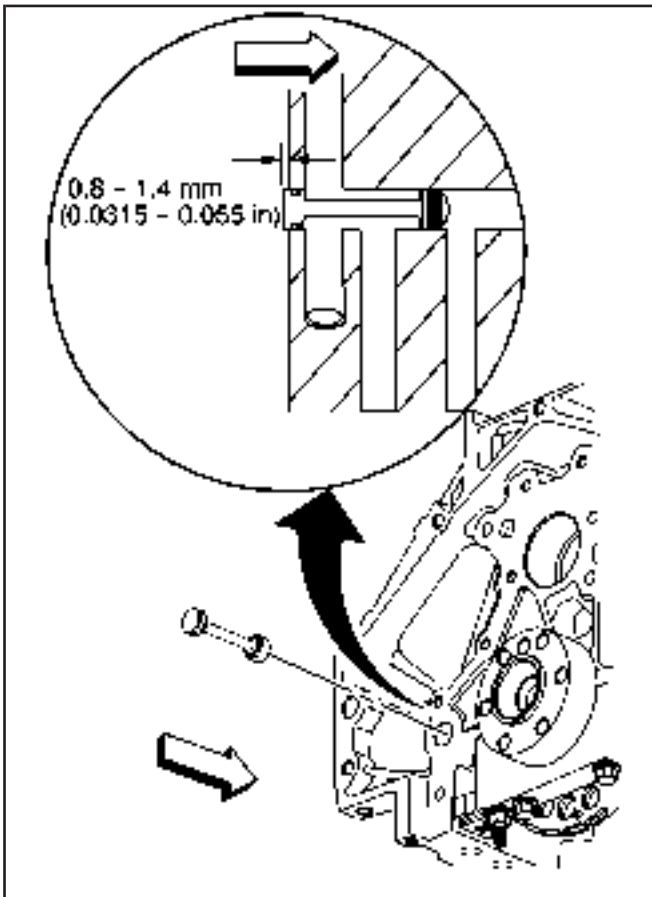


260139



64923

6. Remove the engine block left rear oil gallery plug.
7. Inspect the block plug sealing washers.
If the block plug and heater sealing washers are not damaged, they may be used during assembly.



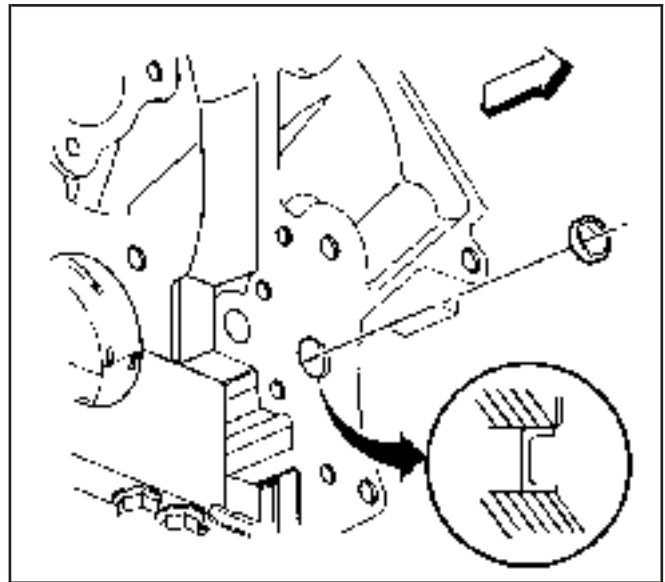
63228

8. Remove the engine block rear oil gallery plug.
9. Inspect the O-ring seal of the rear oil gallery plug.
If the O-ring seal is not cut or damaged, the plug and O-ring seal may be use during assembly.

Important: Remove the front oil gallery plug only if service is required.

If the front oil gallery plug is removed, a NEW oil gallery plug must be installed.

10. Remove the engine block front oil gallery plug.



64295

Engine Block Cleaning and Inspection

SIE-ID = 280907 LMD = 18-mar-2002

Tools Required

- J 8087 Cylinder Bore Gage
- J 42385-100 Thread Repair Kit

1. Clean the following areas:

Notice: SIO-ID = 71569 LMD = 12-aug-1996 Do not use a caustic solution to clean the aluminum engine block.

Important: When cleaning the engine block in a thermal type oven, do not exceed 450°F (232°C).

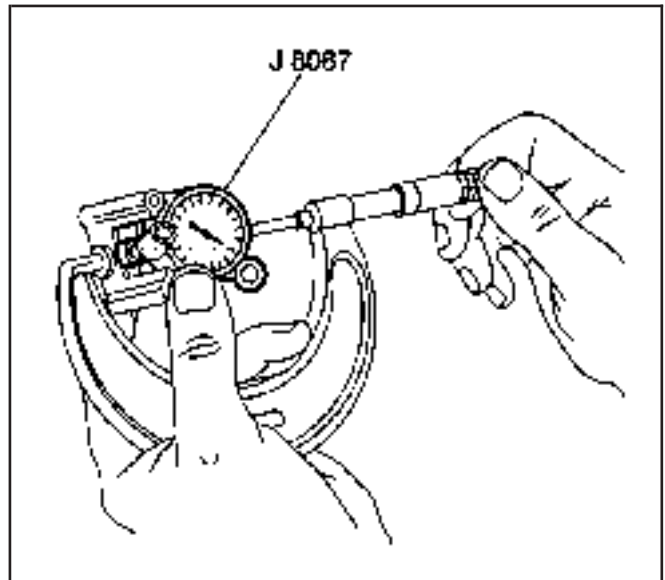
- The engine block in the solvent, to remove all sludge, dirt, or debris
Refer to *Cleanliness and Care*.

Caution: Refer to Safety Glasses Caution in Cautions and Notices.

- Dry the block with compressed air.
- The gasket surfaces
Refer to *Replacing Engine Gaskets*.
- The coolant passages
- The oil galleries
- The main bearing caps
- The engine block cylinder head bolt holes for threadlocking material
Thread repair driver tool J 42385-107 may be used to clean the threads of old threadlocking material.

2. Inspect the following areas:

- The cylinder walls for excessive scratches, gouging, or ring ridge
- The cylinder bores for excessive ring ridge at the top of the cylinder
- The coolant jacket for cracks
- The valve lifter bores for excessive scoring or wear
- The crankshaft bearing webs for cracks



4974

- The gasket sealing surfaces for excessive scratches or gouging

Refer to *Replacing Engine Gaskets*.

- The oil galleries for restrictions
- All threaded bolt holes for damage

3. Measure the following areas:

- The cylinder bores for taper
- The cylinder bores for excessive ring ridge at the top of the cylinder

Measuring the Cylinder for Taper, Out-of-Round, and Oversize

1. Adjust the micrometer to a dimension slightly smaller than the bore size.

Adjust the micrometer to 96.0 mm (3.78 in) for 4.8/5.3 liter engines.

Adjust the micrometer to 101.62 mm (4.0 in) for 6.0 liter engines.

2. Insert the *J 8087* into the micrometer and zero the *J 8087* dial.

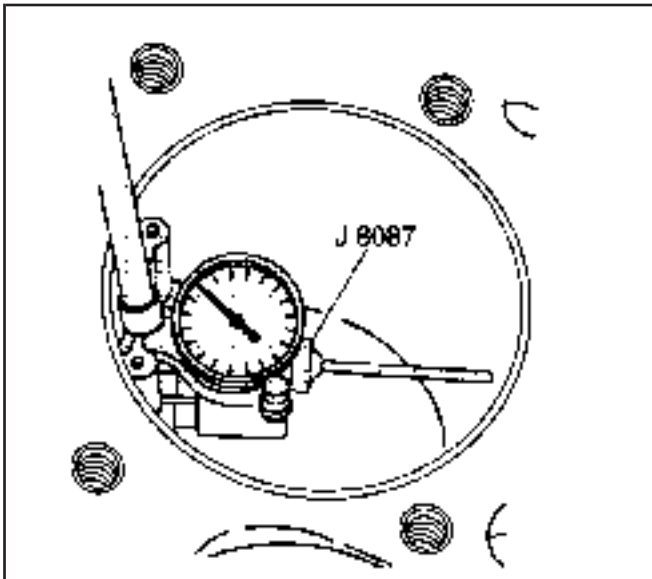
3. Using a *J 8087*, measure the cylinder bore for taper, out-of-round, and oversize.

Slide the *J 8087* up and down throughout the length of the cylinder bore. Check the bore both parallel and perpendicular to the centerline of the crankshaft at the top, center, and bottom of the bore.

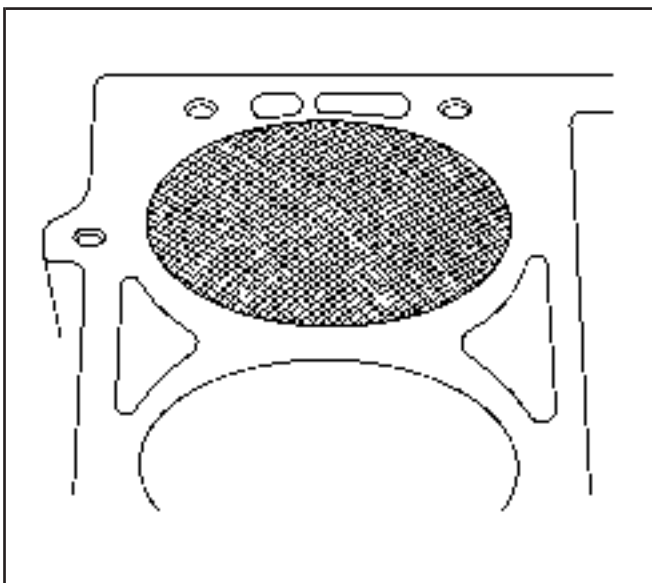
A 4.8/5.3 L cylinder bore that measures 96.000–96.018 mm (3.779–3.78 in) may be honed and serviced with a standard size piston.

A 6.0 L cylinder bore that measures 101.618–101.636 mm (4.0007–4.0014 in) may be honed and serviced with a standard size piston.

A cylinder bore that exceeds the maximum diameter must be serviced with an oversized piston.



4972



186747

Cylinder Boring and Honing

SIE-ID = 280910 LMD = 18-mar-2002

Boring Procedure

Important: A 0.5 mm (0.02 in) oversize service piston and a piston ring set are available for the 4.8/5.3/6.0 liter engines.

1. Measure all pistons with a micrometer to determine the cylinder bore diameter.
2. Before you use any type of boring bar, use a fine file and clean the top of the cylinder block removing any dirt or burrs. If you do not inspect the cylinder block, the boring bar may be improperly positioned, tilted, and the cylinder bore could be bored at an incorrect angle.
3. Carefully follow the instructions furnished by the manufacturer regarding use of the equipment.

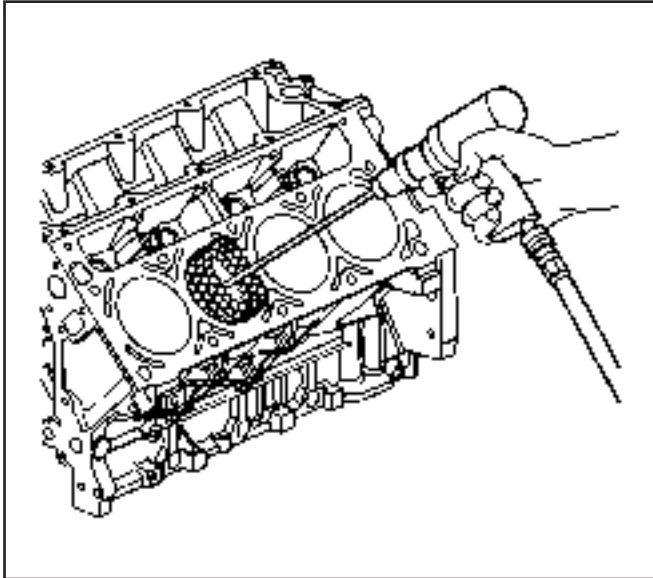
4. When you bore the cylinders, ensure all the crankshaft bearing caps are in place. Tighten the crankshaft bearing caps to the proper torque in order to avoid distortion of the cylinder bores during final assembly.
5. When you take the final cut with a boring bar, leave 0.03 mm (0.001 in) on the cylinder bore diameter for the finish honing and fit of the piston.

Honing Procedure

1. When honing the cylinders, follow the manufacturer's recommendations for equipment use, cleaning, and lubrication. Use only clean, sharp stones of the proper grade for the amount of material you remove. Dull, dirty stones cut unevenly and generate excessive heat. Do not hone to final clearance with a coarse or medium-grade stone. Leave sufficient metal so that all stone marks may be removed with fine-grade stones. Perform final honing with a fine-grade stone, honing the cylinder to the proper clearance.
2. During the honing operation, thoroughly clean the cylinder bore. Repeatedly inspect the cylinder bore for fit with the selected piston.
All measurements of the piston or the cylinder bore should be made with the components at normal room temperature.
3. When honing a cylinder for fit to an oversize piston, first perform the preliminary honing with a 100 grit stone.
4. Perform final cylinder honing with a 240 grit stone and obtain a 45 degree cross hatch pattern.
A 240 grit stone is preferred for final honing. If a 240 grit stone is not available, a 220 grit stone may be used as a substitute.
5. When honing to eliminate taper in the cylinder, make full strokes the complete length of the bore.
Repeatedly observe the measurement at the top, the middle, and the bottom of the bore.
6. The finish marks should be clean but not sharp. The finish marks should also be free from imbedded particles and torn or folded metal.
7. By measuring the selected piston at the sizing point and by adding the average of the clearance specification, you can determine the final cylinder honing dimension required.
8. When finished, the reconditioned cylinder bores should have less than or meet the specified out-of-round and taper requirements.
9. After final honing and before the piston is inspected for fit, clean the cylinder bores with hot water and detergent. Scrub the bores with a stiff bristle brush and rinse the bores thoroughly with hot water. Do not allow any abrasive material to remain in the cylinder bores. This abrasive material may cause premature wear of the new piston rings and the cylinder bores. Abrasive material will also contaminate the engine oil and

may cause premature wear of the bearings. After washing the cylinder bore, dry the bore with a clean rag.

10. Perform final measurements of the piston and the cylinder bore.
11. Permanently mark the top of the piston for the specific cylinder to which it has been fitted.
12. Apply clean engine oil to each cylinder bore in order to prevent rusting.

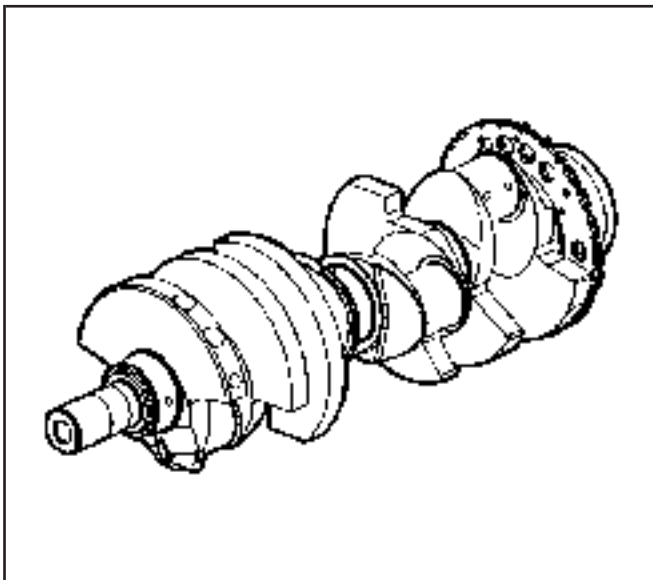


490757

Deglazing Procedure

Using a ball type or self centering honing tool, deglaze the cylinder bore lightly. Deglazing should be done only to remove any deposits that may have formed. Use a 240 grit stone of silicone carbide or equivalent material when performing the deglazing procedure.

A 240 grit stone is preferred for final honing. If a 240 grit stone is not available, a 220 grit stone may be used as a substitute.



156153

Crankshaft and Bearings Cleaning and Inspection

SIE-ID = 823824 LMD = 10-jun-2002

Tools Required

- J 6125-1B Slide Hammer
- J 7872 Magnetic Base Dial Indicator Set
- J 36660-A Torque Angle Meter
- J 41818 Crankshaft Bearing Cap Remover
- J 43690 Rod Bearing Checking Tool
- J 43690-100 Rod Bearing Checking Tool – Adapter Kit

Cleaning Procedure

Important: Use care when handling the crankshaft. Avoid damage to the bearing surfaces or the lobes of the crankshaft position reluctor ring. Damage to the teeth of the crankshaft position reluctor ring may effect On-Board Diagnostics (OBD) II system performance.

1. Clean the crankshaft with solvent.
2. Thoroughly clean all oil passages and inspect for restrictions or burrs.

Caution: Refer to Safety Glasses Caution in Cautions and Notices.

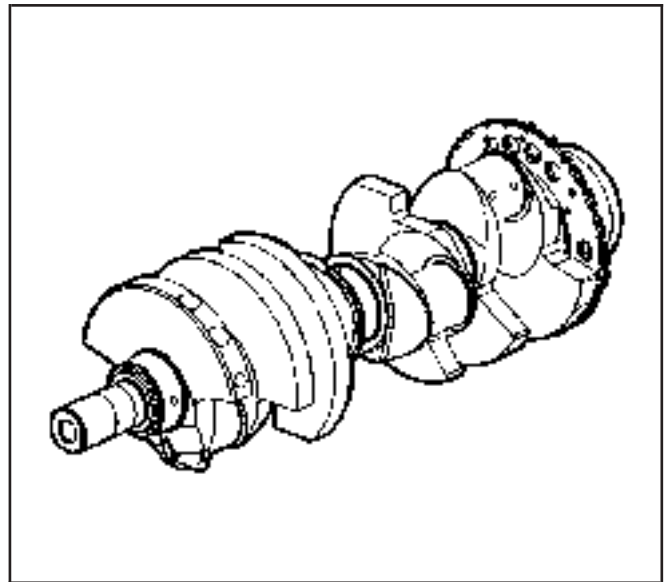
3. Dry the crankshaft with compressed air.

Inspection Procedure

Important: The reluctor ring teeth should not have imperfections on the rising or falling edges.

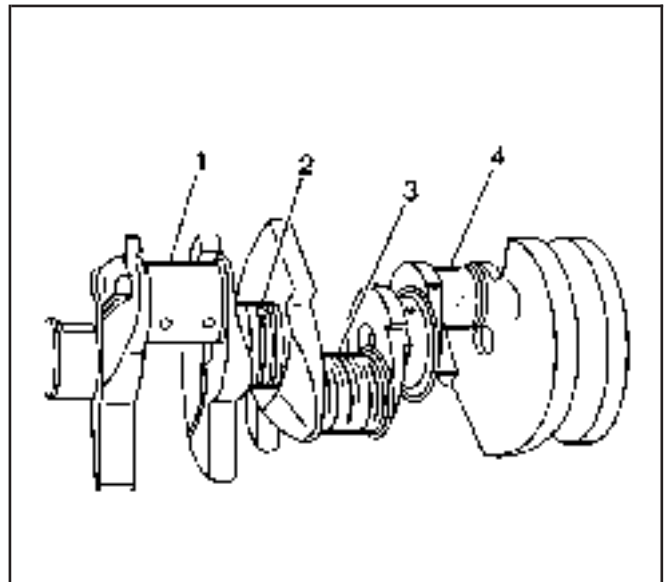
Imperfections of the reluctor ring teeth may effect OBD II system performance.

1. Perform a visual inspection of the crankshaft for damage.
2. Inspect the crankshaft position reluctor ring lobes for damage.



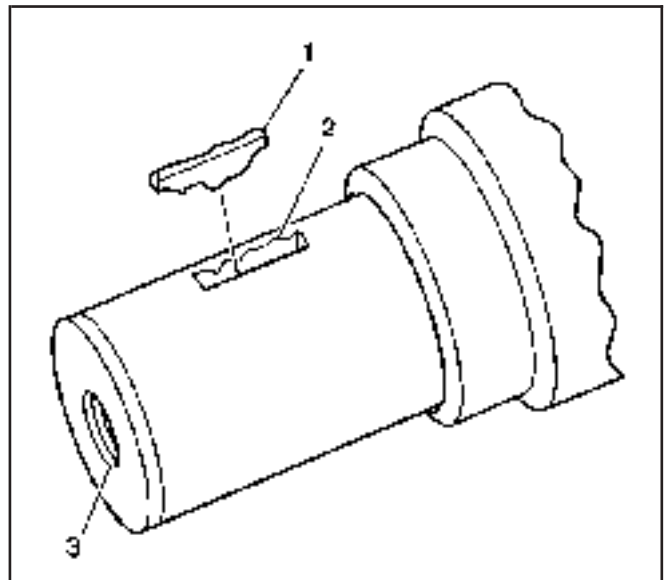
156153

3. Inspect the crankshaft journals for wear (1). Journals should be smooth with no signs of scoring, wear, or damage.
4. Inspect the crankshaft journals for grooves or scoring (2).
5. Inspect the crankshaft journals for scratches or wear (3).
6. Inspect the crankshaft journals for pitting or imbedded bearing material (4).

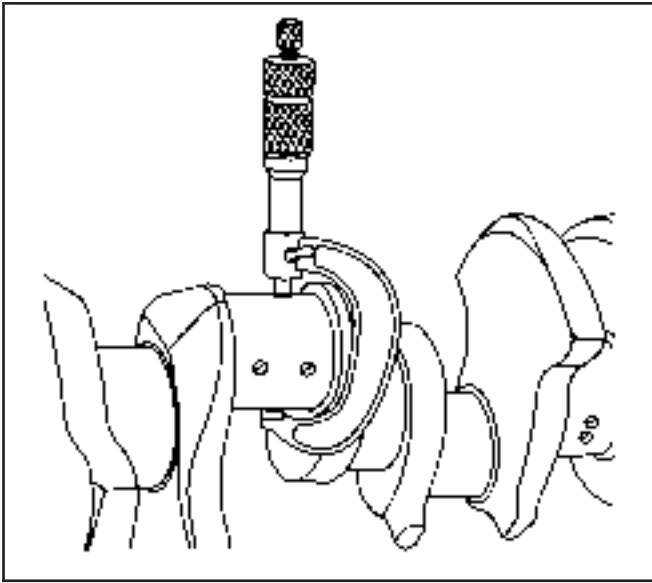


156170

7. Inspect the crankshaft key (1), keyway (2), and threaded hole (3) for damage.

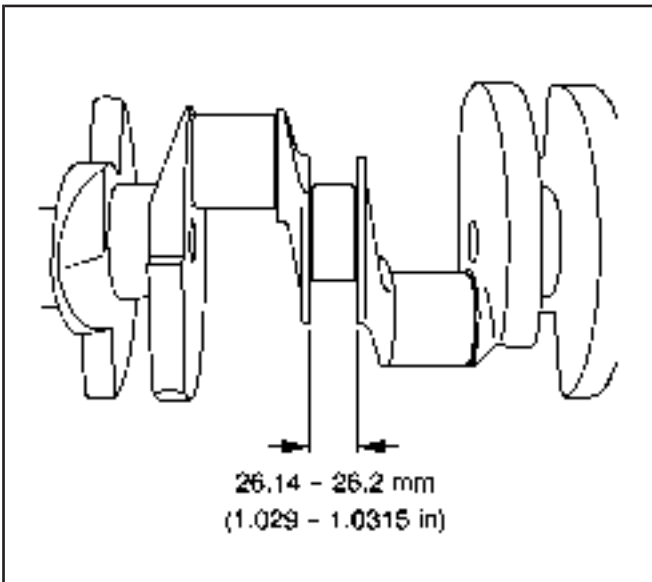


188090



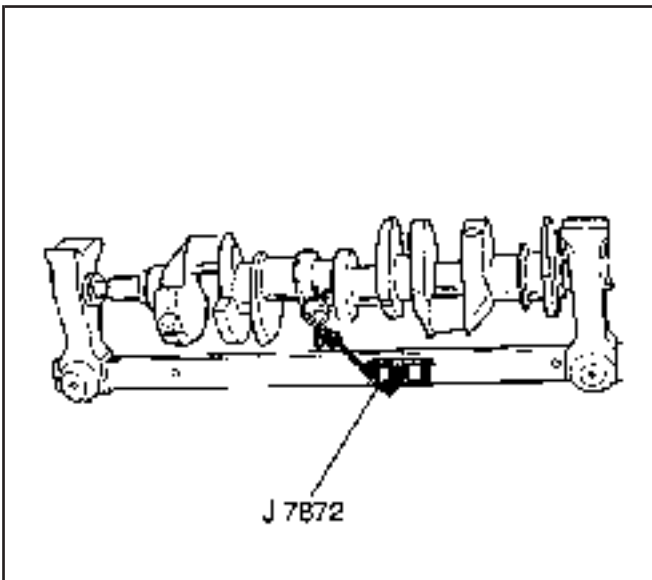
35207

8. Measure the crankpins for the out-of-round.
9. Measure the crankpins for taper.



490749

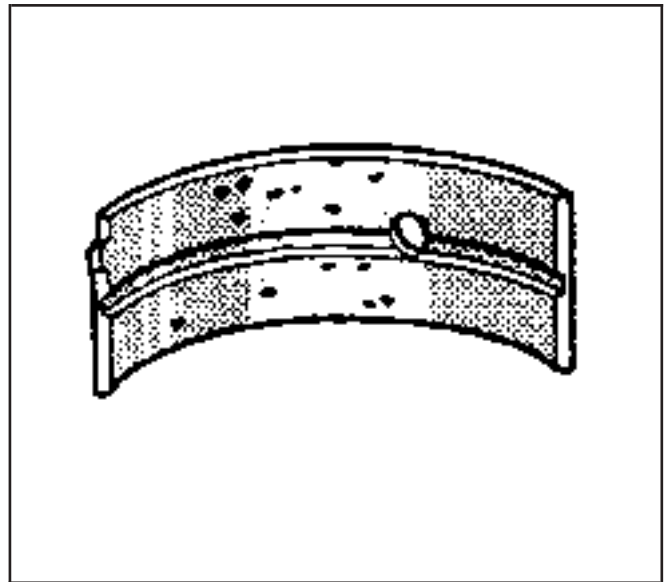
10. Measure the crankshaft thrust wall width.
A crankshaft with a thrust wall width in excess of 26.2 mm (1.0315 in) must be replaced.



35210

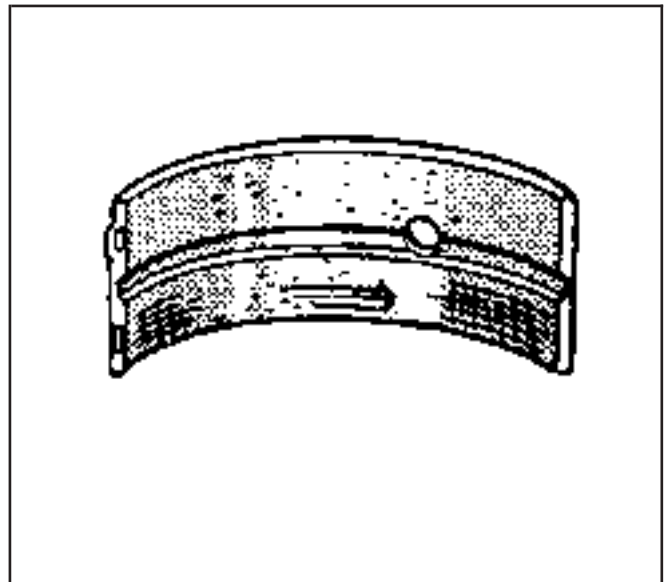
11. Measure the crankshaft runout.
Use wooden V blocks or a fixture to support the crankshaft on the front and rear journals.
12. Use the *J 7872* in order to measure the crankshaft runout at the front and rear intermediate journals.
13. Use the *J 7872* in order to measure the runout of the crankshaft rear flange.
14. Use the *J 7872* in order to measure the runout of the crankshaft position reluctor ring. Reluctor ring runout should be measured 1.0 mm (0.04 in) below the ring teeth.
If the reluctor ring has runout in excess of 0.7 mm (0.028 in), replace the crankshaft.

- 15. Inspect crankshaft bearings for craters or pockets. Flattened sections on the bearing halves also indicate fatigue.



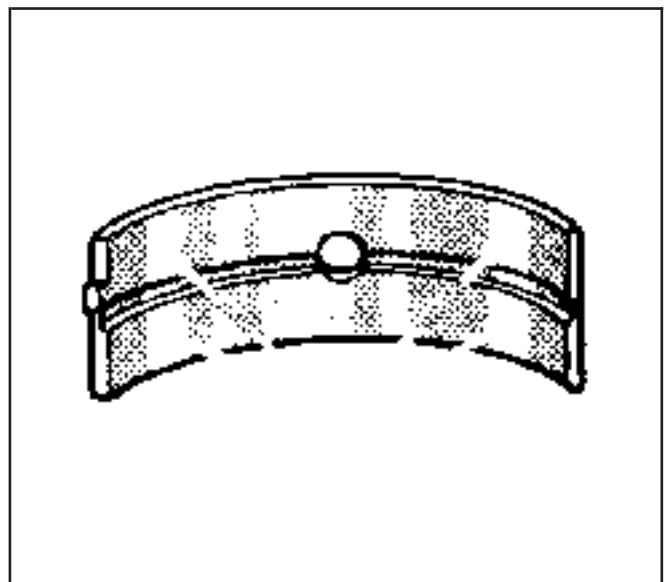
52051

- 16. Inspect the crankshaft bearings for excessive scoring or discoloration.
- 17. Inspect the crankshaft bearings for dirt or debris imbedded into the bearing material.

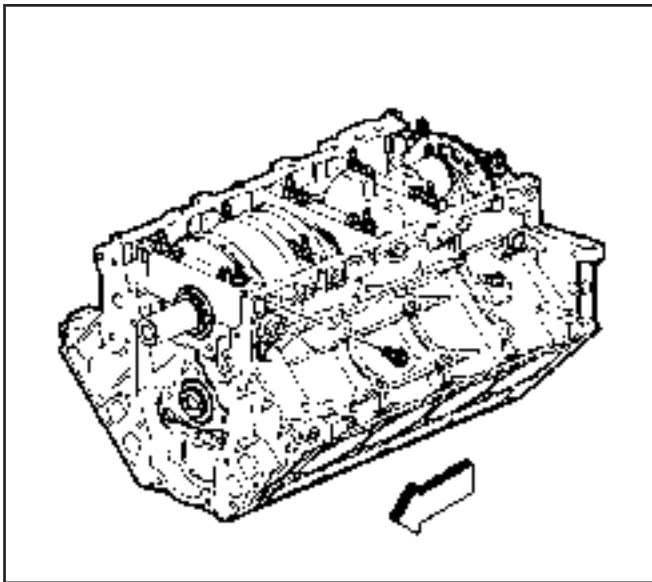


52053

- 18. Inspect the crankshaft bearings for improper seating indicated by bright, polished sections of the bearing.
 If the lower half of the bearing is worn or damaged, both upper and lower halves should be replaced.
 Generally, if the lower half is suitable for use, the upper half should also be suitable for use.



52056



156155

Measuring Main Bearing Clearance – Gaging Plastic Method

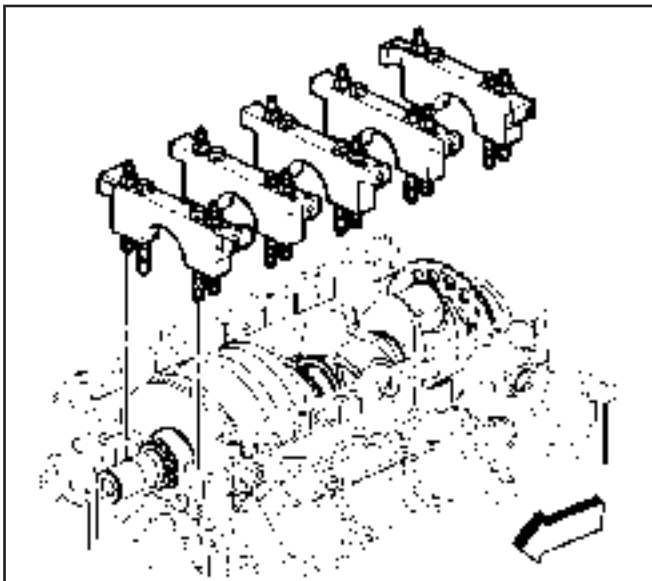
Important: The crankshaft main bearings are a precision insert type. Main bearing caps are machined with the engine block for proper clearance and cannot be shimmed or filed for bearing fit. If the clearances are found to be excessive, new bearings and/or engine block and cap repair or replacement may be required.

Do not rotate the crankshaft while gaging plastic is between the crankshaft journal and the bearing surface.

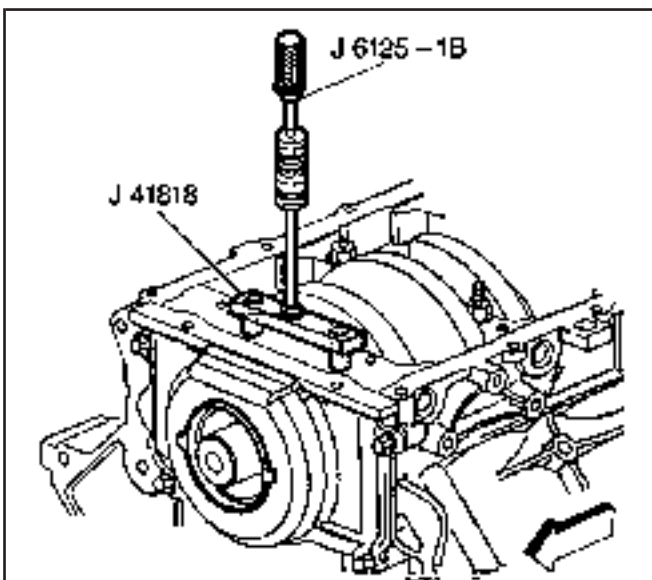
The crankshaft bearing clearances are critical. Excessive bearing clearance may effect crankshaft position sensor signals and may effect On-Board Diagnostics (OBD) II system operation.

Important: Remove the bearing cap side bolts prior to cap removal.

1. Remove the bearing cap M8 side bolts.
2. Remove the bearing cap M10 bolts and studs.



156152



63188

Notice: Refer to *Fastener Notice* in Cautions and Notices.

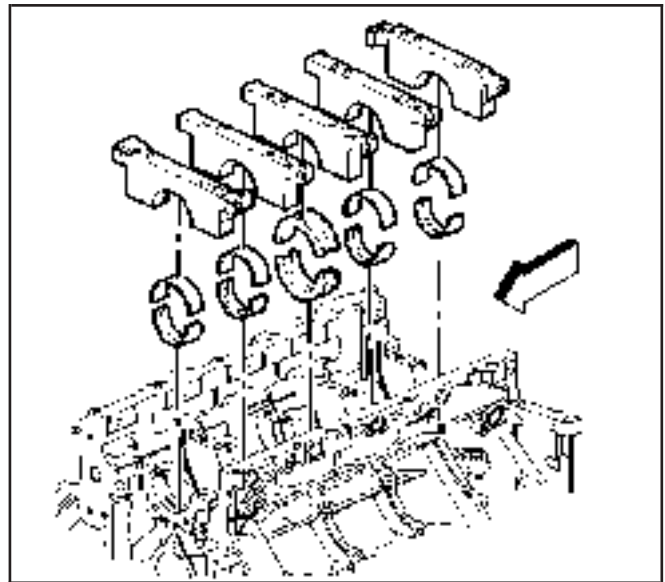
3. Install the *J 41818* to the bearing cap.

Tighten

Tighten the *J 41818* bolts to 11 N·m (100 lb in).

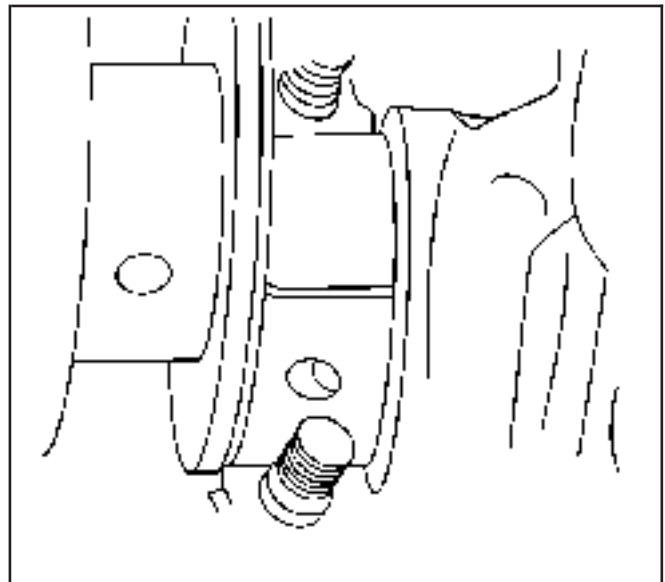
4. Install the *J 6125-1B* to the *J 41818* in order to remove the bearing cap.

5. Remove the bearing cap and lower bearing.



64293

6. Install gaging plastic onto the crankshaft journal. Install the gaging plastic the full width of crankshaft bearing journal.

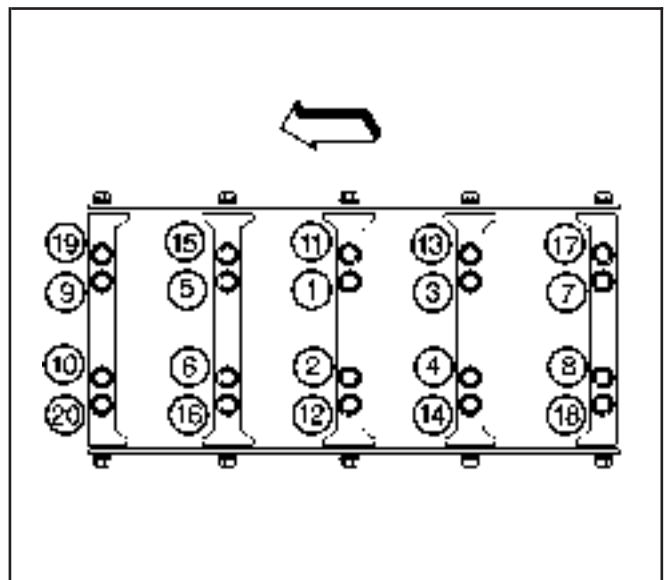


4980

7. Install the bearing, bearing cap, bolts and bolt/studs.

Tighten

- 7.1. Tighten the inner bolts (1–10) a first pass in sequence to 20 N·m (15 lb ft).
- 7.2. Tighten the inner bolts (1–10) a final pass in sequence to 80 degrees using the *J 36660-A*.
- 7.3. Tighten the outer bolt/studs (11–20) a first pass in sequence to 20 N·m (15 lb ft).
- 7.4. Tighten the outer bolt/studs (11–20) a final pass in sequence to 53 degrees using the *J 36660-A*.
- 7.5. Tighten the side cap bolts to 25 N·m (18 lb ft).

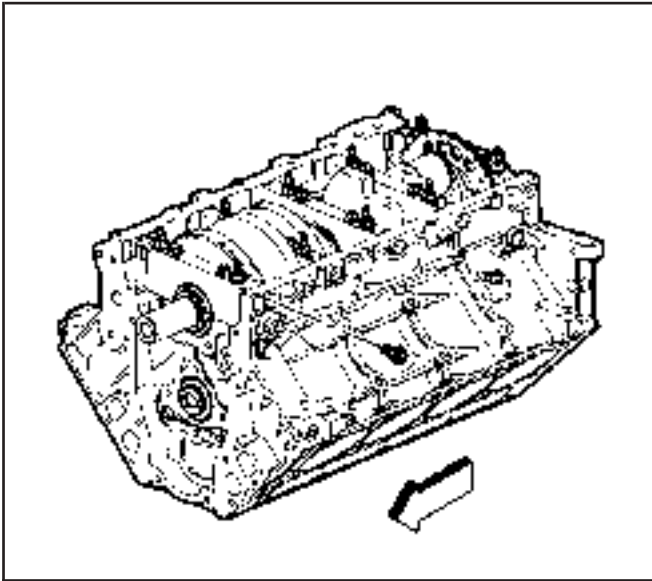


63214

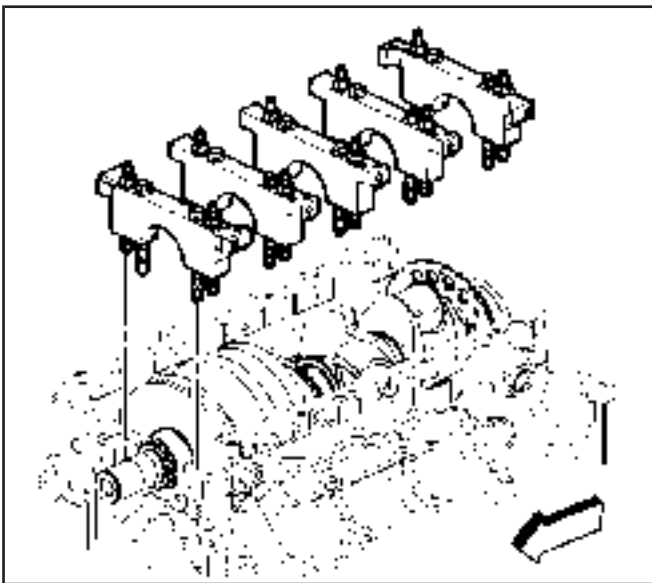
Tighten the bolt on one side of the bearing cap and then tighten the bolt on the opposite side of the same bearing cap.

Important: Remove the bearing cap side bolts prior to cap removal.

8. Remove the bearing cap M8 side bolts.



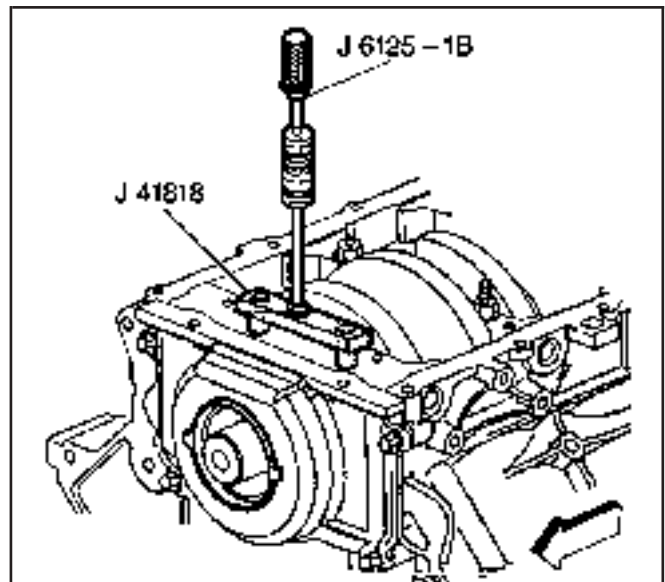
156155



156152

9. Remove the bearing cap bolts and bolt/studs.

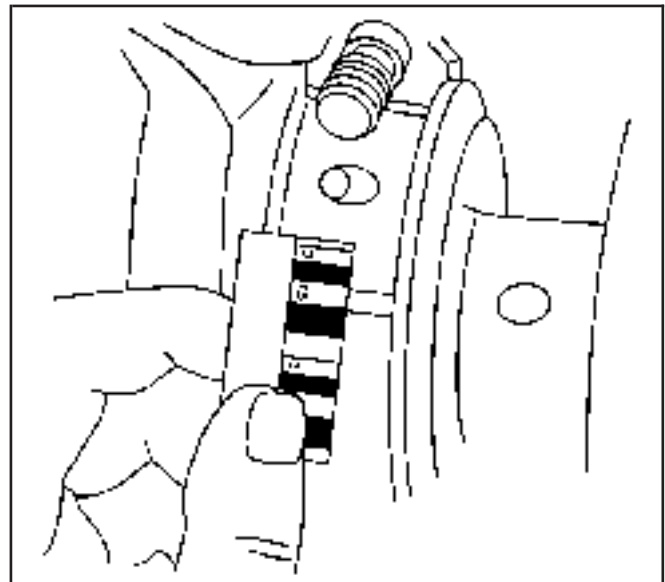
10. Use the *J 41818* and the *J 6125-1B* in order to remove the bearing cap.



63188

11. Measure the gaging plastic at its widest area using the scale supplied with the plastic gaging kit.

- If the gaging plastic shows irregularity in the journal exceeding 0.025 mm (0.001 in), remove the crankshaft and measure the journal with a micrometer.
- If the bearing clearance is greater than 0.052 mm (0.0021 in), select and install an undersized bearing set, and measure the clearance with gaging plastic.
- If clearance cannot be brought to specifications, replace the crankshaft or grind the crankshaft for use with the next undersized bearing.



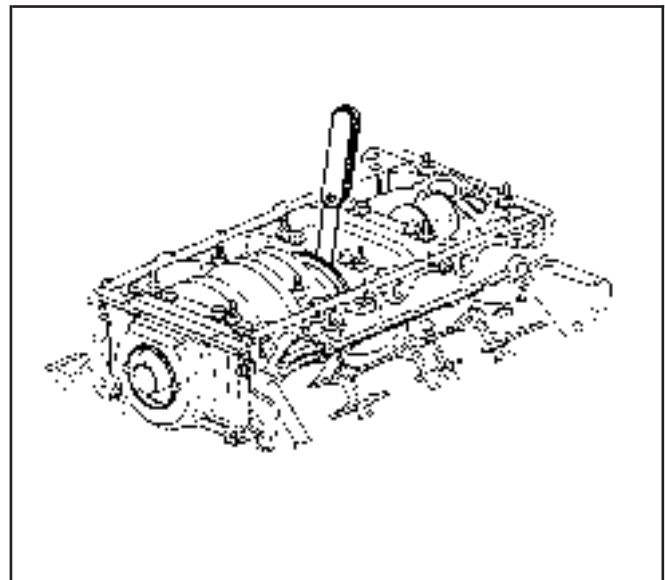
4981

12. Measure the crankshaft end play.

- 12.1. Thrust the crankshaft forward or rearward.
- 12.2. Insert a feeler gage between the center crankshaft bearing and the bearing surface of the crankshaft and measure the bearing clearance.

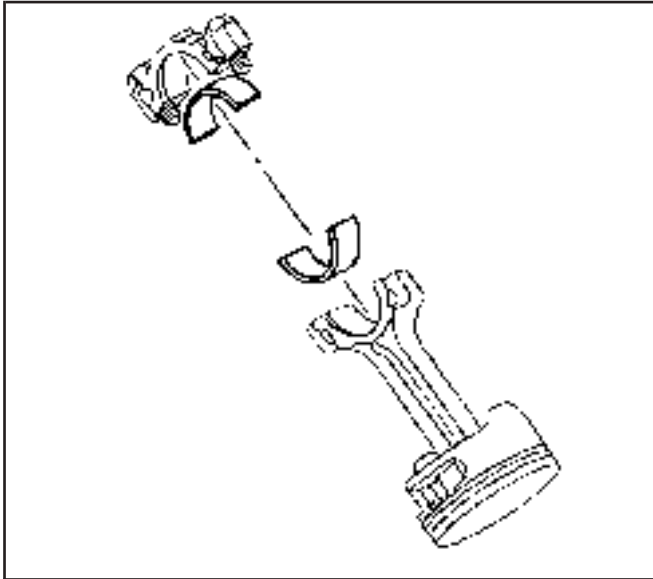
The proper crankshaft end play clearance is 0.04–0.2 mm (0.0015–0.0078 in).

- 12.3. If the bearing clearance is not within specifications:
 - Inspect the thrust surfaces for nicks, gouges or raised metal. Minor imperfections may be removed with a fine stone.
 - Replace the thrust bearings and measure the end play.



64316

- If the correct measurements cannot be obtained, repair the crankshaft thrust surfaces or replace the crankshaft.



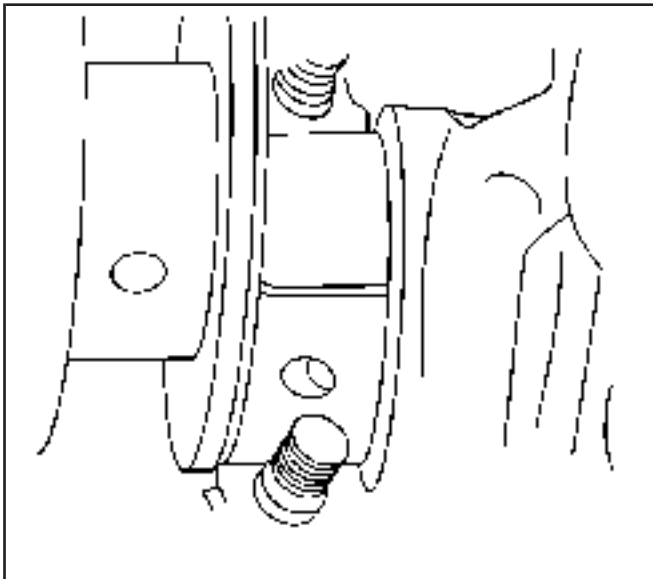
53223

Measuring Connecting Rod Bearing Clearance – Gaging Plastic Method

Important: Connecting rod bearings are a precision insert type. Connecting rods are of a powdered metal design and cannot be shimmed or filed for bearing fit. If clearances are found to be excessive, a new bearing and/or connecting rod are required.

Do not rotate the crankshaft while gauging plastic is between the crankshaft journal and the bearing surface.

1. Remove the bearing cap, bearing half and bolts.
2. Install the gaging plastic onto the connecting rod bearing journal. Install the gaging plastic the full width of the journal.



4980

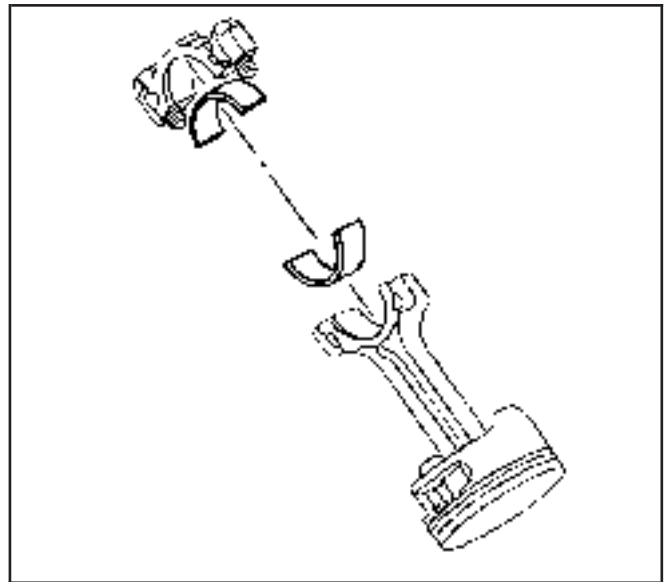
3. Install the bearing cap, bearing, and bolts.

Tighten

3.1. Tighten the connecting rod bolts first pass to 20 N·m (15 lb ft).

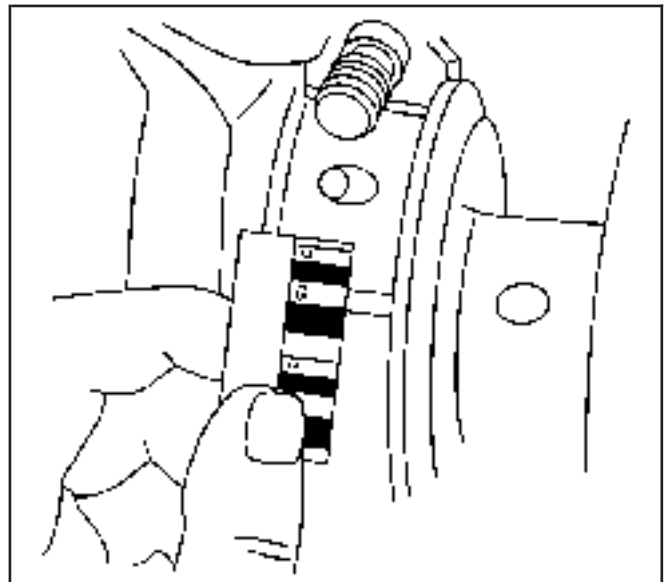
3.2. Tighten the connecting rod bolts a final pass to 75 degrees using the J 36660-A. Refer to *Piston, Connecting Rod, and Bearing Installation*.

4. Remove the bearing cap, bearing, and bolts.



53223

5. Measure the gaging plastic at its widest area using the scale supplied with the plastic gaging kit. The connecting rod bearing clearance should be 0.023–0.076 mm (0.0009–0.003 in).



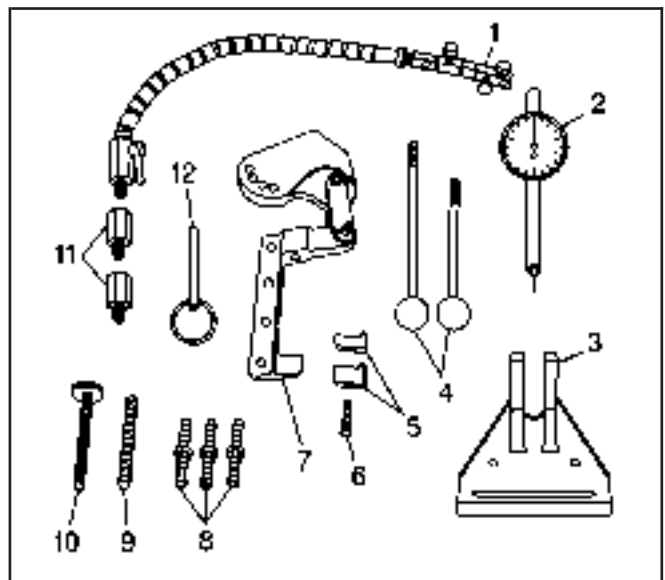
4981

Measuring Connecting Rod Bearing Clearance – Using J 43690/J 43690-100

J 43690 and J 43690-100 have been developed as a more accurate method to measure connecting rod bearing clearances. The instructions below provide an overview of tool set-up and usage. For more detailed information, refer to the tool instruction sheets as supplied by the tool manufacturer.

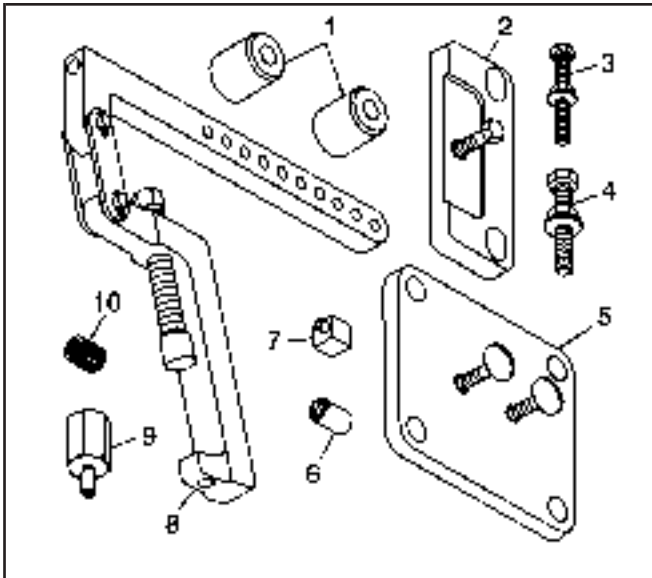
J 43690 Rod Bearing Checking Tool

- J 43690-20 Swivel Base (1)
- J 43690-19 Dial Indicator (2)
- J 43690-2 Base (3)
- J 43690-5, -6 Handle (4)
- J 43690-10, -11 Foot (5)
- 280307 Screw (6)
- J 43690-1 Pivot Arm Assembly (7)
- J 43690-3, -7, -8 Screws (8)



627091

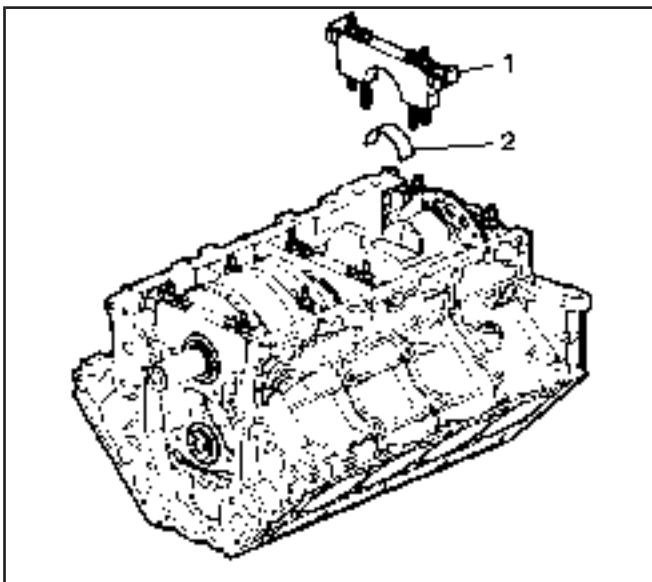
- 280319 Screw (9)
- 280311 Screw (10)
- J 43690-17, -18 Adapter (11)
- 280310 Pin (12)



836375

J 43690-100 Rod Bearing Checking Tool – Adapter Kit

- J 43690-104 Spacer (1)
- J 43690-105 Retainer Plate (2)
- 505478 Bolt (3)
- 511341 Bolt (4)
- J 43690-106 Retainer Plate (5)
- J 43690-107 Cap (6)
- J 43690-102 Foot (7)
- J 43690-101 Pivot Arm Assembly (8)
- J 43690-103 Adapter (9)
- 505439 Adapter (10)

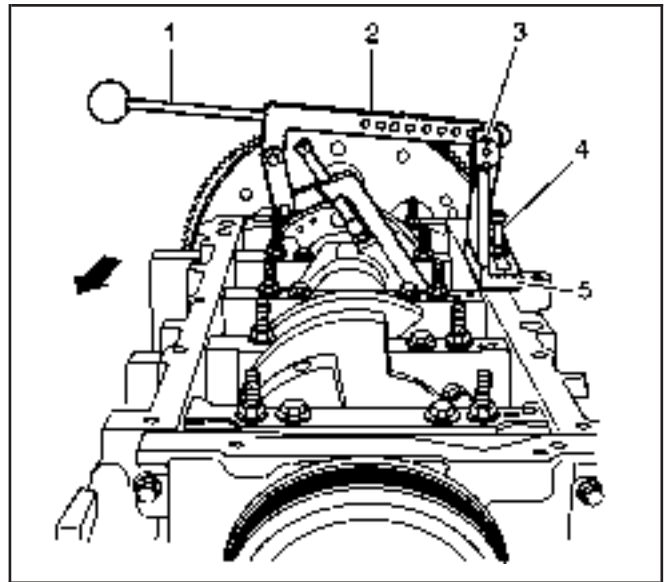


863074

Important: The crankshaft must be secure with no movement or rotation in order to obtain an accurate reading.

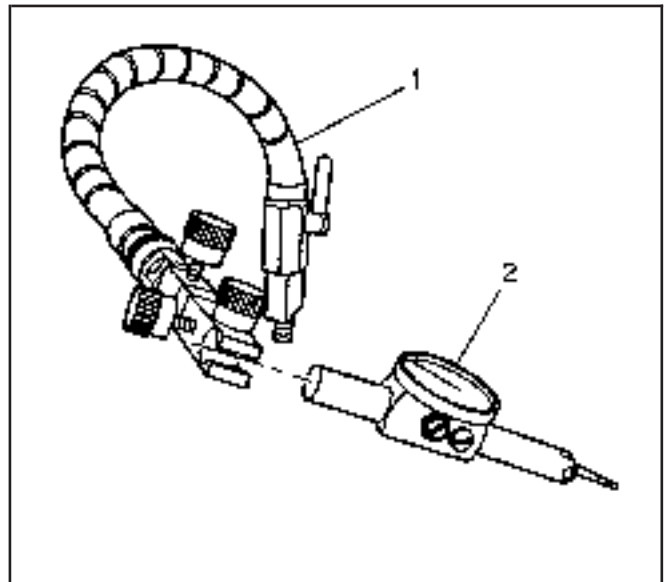
1. Rotate the crankshaft until the journal/connecting rod to be measured is in the 12 o'clock position.
2. Remove a bearing cap and bolts (1).
3. Remove the bearing half (2).
4. Insert a piece of paper card stock onto the crankshaft journal.
5. Install the bearing half (2) and cap and bolts (1). Refer to *Fastener Tightening Specifications*.

6. Install the following:
 - 6.1. J 43690-2 (5)
 - 6.2. J 43690-3 (4)
 - 6.3. J 43690-101 (2)
 - 6.4. 280310 (3)
 - 6.5. J 43690-5 (1)



828697

7. Install the swivel base (1) and dial indicator (2).
8. Adjust per the manufacturers instructions and measure the connecting rod bearing clearance. A connecting rod with a clearance in excess of 0.076 mm (0.003 in) is considered excessive. Service components as required.



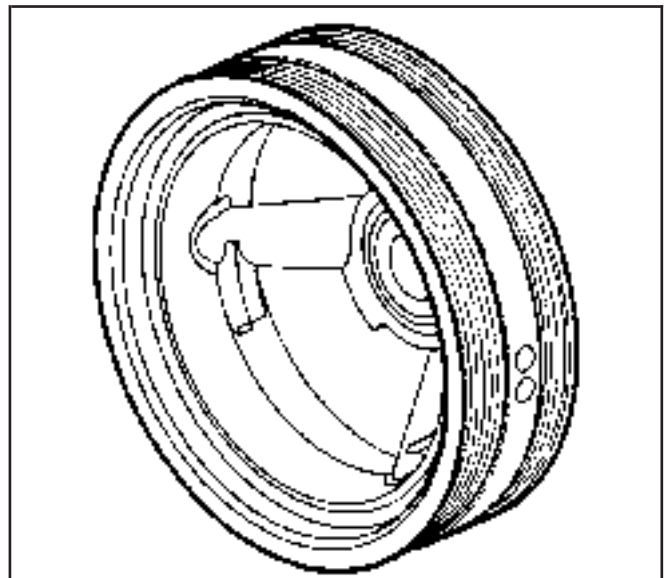
627122

Crankshaft Balancer Cleaning and Inspection

SIE-ID = 281878 LMD = 24-jul-1998

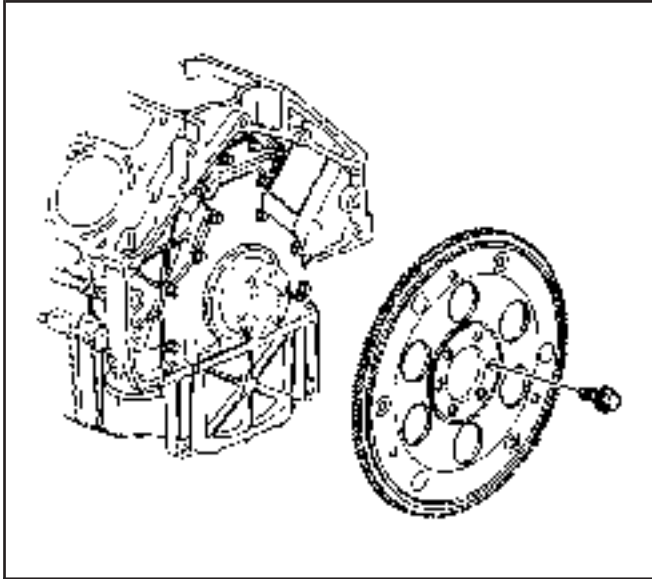
1. Clean the crankshaft balancer in solvent.
2. Clean the belt grooves of all dirt or debris with a wire brush.
3. Dry the crankshaft balancer with compressed air.
4. Inspect the crankshaft balancer for the following:
 - Worn, grooved, or damaged hub seal surface
A crankshaft balancer hub seal surface with excessive scoring, grooves, rust or other damage must be replaced.
Minor imperfections on the hub seal surface may be removed with polishing compound or fine grade emery cloth.

Important: In order for the belt to track properly, the belt grooves should be free of all dirt or debris.



260155

- Dirty or damaged belt grooves
The balancer belt grooves should be free of any nicks, gouges, or other damage that may not allow the belt to track properly. Minor imperfections may be removed with a fine file.
- Worn, chunking or deteriorated rubber between the hub and pulley



178458

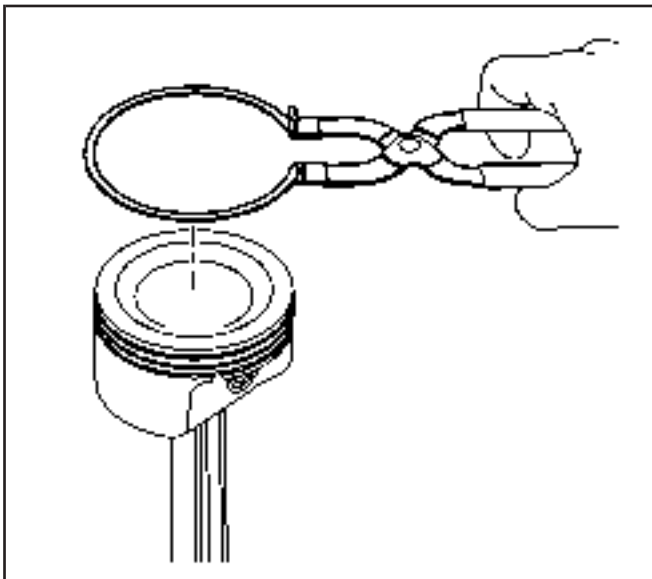
Engine Flywheel Cleaning and Inspection

SIE-ID = 824404 LMD = 06-oct-2001

1. Clean the flywheel in solvent.
2. Dry the flywheel with compressed air.
3. Inspect the automatic transmission flywheel for the following conditions:
 - Damaged ring gear teeth
 - Stress cracks around the flywheel-to-crankshaft bolt hole locations

Important: Do not attempt to repair the welded areas that retain the ring gear to the flywheel plate. Install a new flywheel.

- Welded areas that retain the ring gear onto the flywheel for cracking



490763

Piston and Connecting Rod Disassemble

SIE-ID = 741677 LMD = 18-mar-2002

Important: Certain 6.0L LQ9 engines will use a full-floating piston and pin design. In those applications, the pin is retained in the piston by retaining clips.

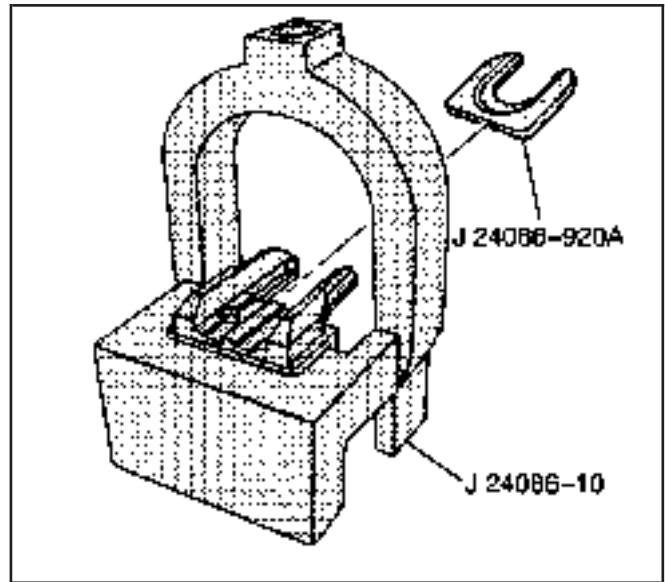
Press Fit Piston Pin

Tools Required

J 24086-C Piston Pin Remover/Installer Set

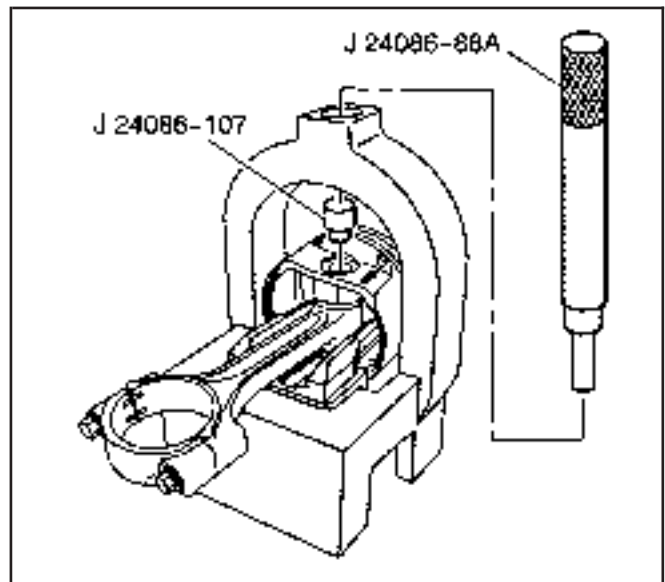
1. Using piston ring pliers, remove the piston rings from the piston.

2. Install fork insert J 24086-920A into fixture J 24086-10.



533477

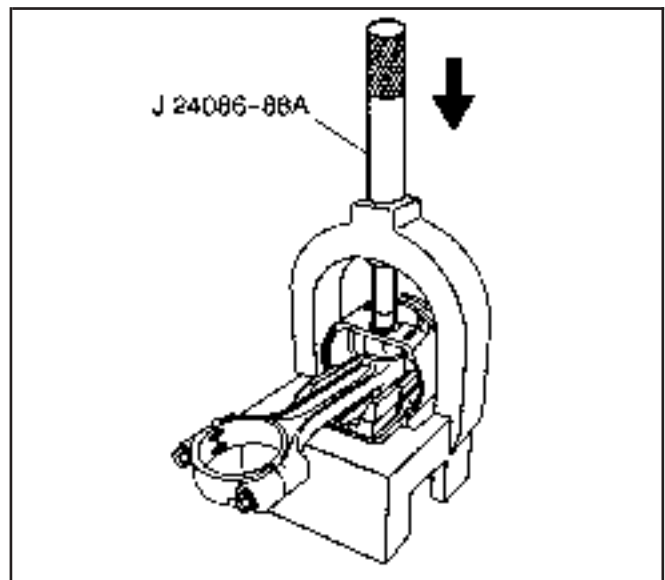
3. Install the piston and connecting rod assembly onto J 24086-10.
4. Install J 24086-107 into the piston pin and J 24086-88A through the fixture and into J 24086-107.



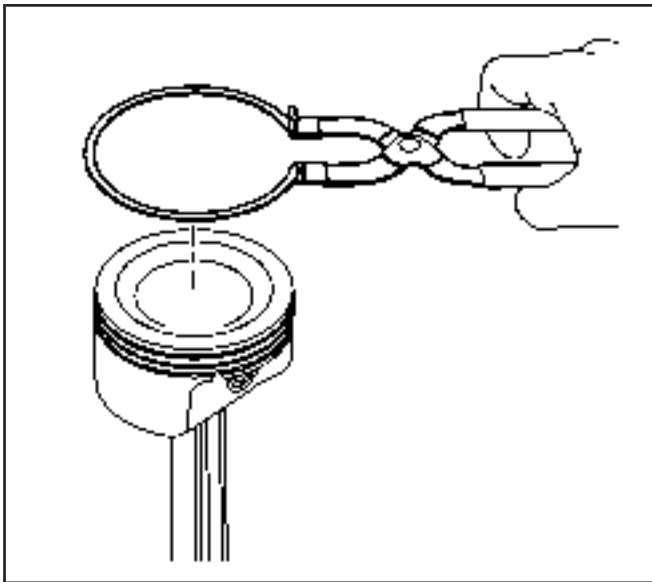
533478

Notice: SIO-ID = 5015 LMD = 25-feb-2000 After the installer hub bottoms on the support assembly, do not exceed 35 000 kPa (5,000 psi) pressure, this could cause damage to the tool.

5. Press the piston pin from the piston and connecting rod assembly.



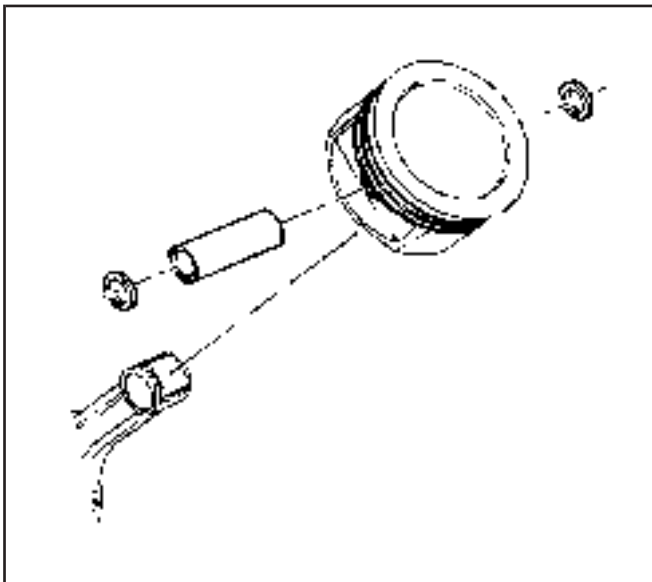
533480



490763

Full Floating Piston Pin

1. Using piston ring pliers, remove the piston rings from the piston.
2. Remove the piston pin retaining clips.
3. Remove the pin from the piston and connecting rod.
4. The piston and pin are a matched set and are not to be serviced separately. Mark, sort, or organize the piston and the matching piston pin. Refer to *Separating Parts*.



35866

Piston, Connecting Rod, and Bearings Cleaning and Inspection

SIE-ID = 741679 LMD = 23-aug-2001

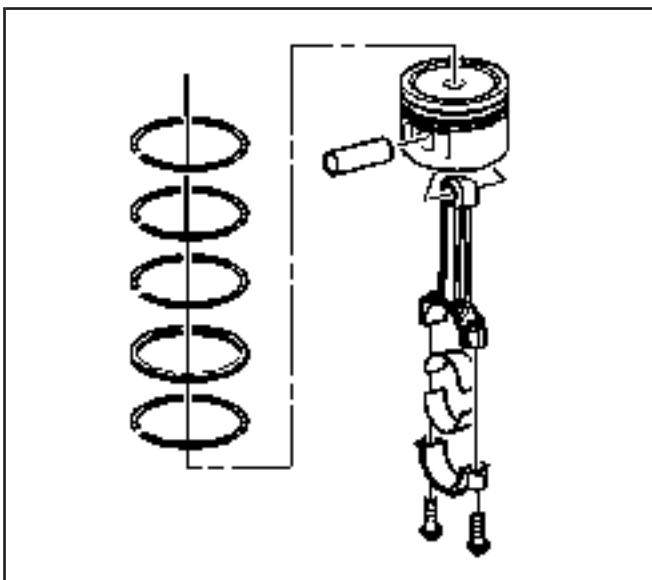
Piston and Pin

Important: Replace the pistons and the pins that are damaged or show signs of excessive wear.

The piston and the pin are a matched set. If service is required, replace the piston and the pin as an assembly.

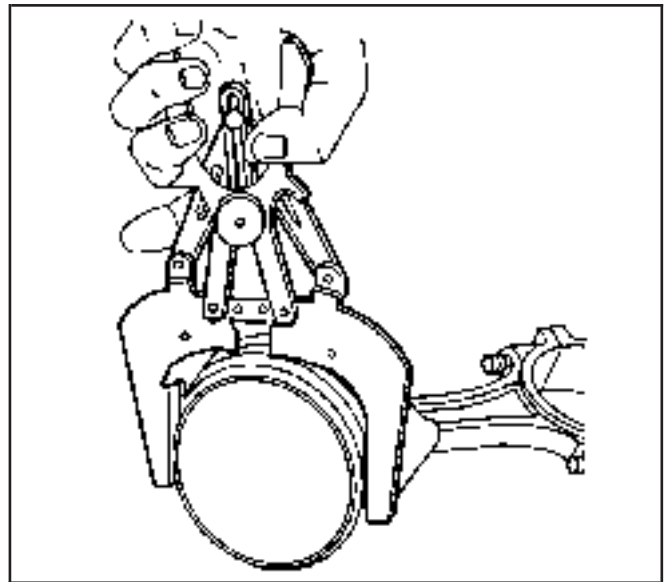
Do not wire brush any part of the piston.

1. Clean the varnish from the piston and the pin with cleaning solvent.
2. Dry the piston and the pin with compressed air.



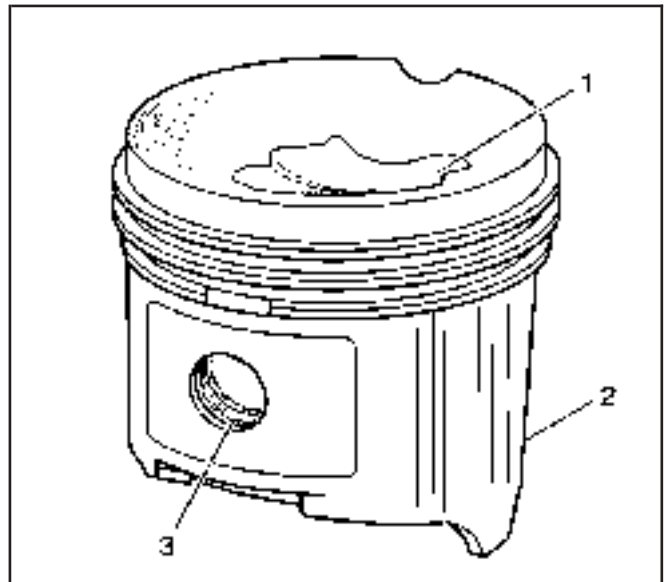
64180

3. Clean the piston ring grooves with a suitable ring groove cleaning tool.
4. Clean the oil lubrication holes and slots.



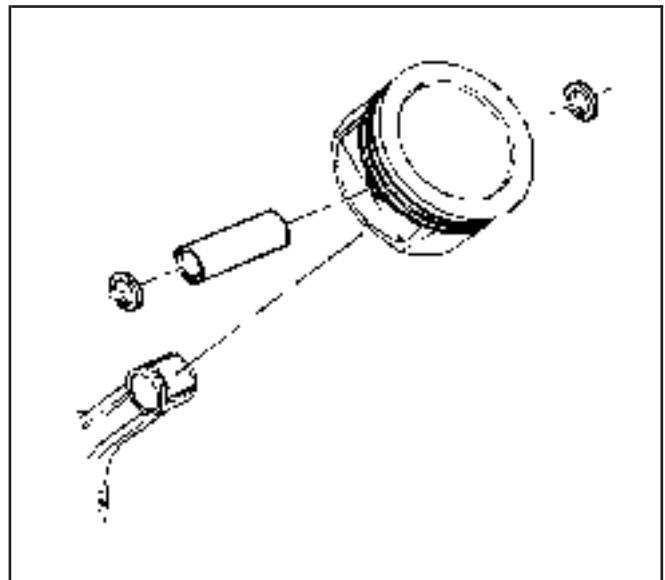
4977

5. Inspect the piston and the pin for the following:
 - Cracks in the piston ring lands, the piston skirt, or the pin bosses
 - Piston ring grooves for nicks, burrs, or warpage which may cause the piston ring to bind
MINOR imperfections may be removed from the piston with a fine file.
 - Scuffed or damaged skirts (2)
 - Eroded areas at the top of the piston (1)
 - Scoring to the piston pin bore (3) or the piston pin

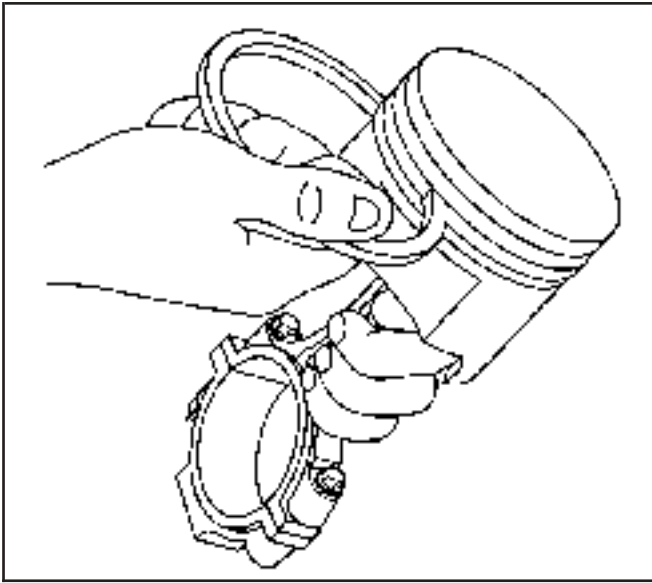


156168

6. For certain 6.0 L applications, inspect for bent pin retaining clips or damage to the clip groove of the piston.



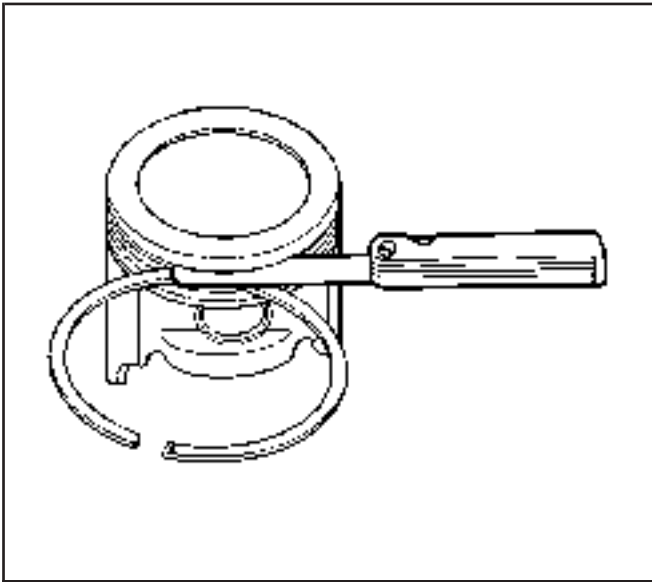
35866



4969

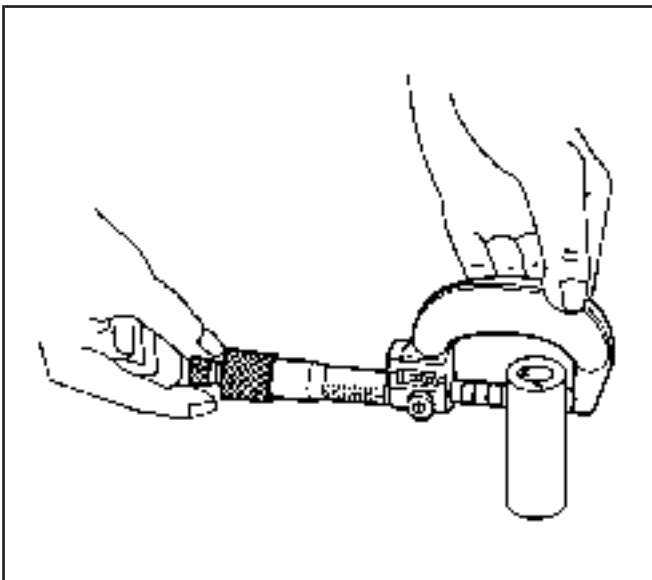
Important: Measurements of components should be taken with the components at normal room temperature.

7. Measure the piston ring-to-piston ring groove side clearance.
 - 7.1. Insert the edge of the piston ring into the piston ring groove.
 - 7.2. Roll the piston ring completely around the piston.
 - If binding is caused by a distorted piston ring groove, MINOR ring groove imperfections may be removed with a fine file.
 - If binding is caused by a distorted piston ring, replace the piston ring.



22934

8. Measure the piston ring side clearance with a feeler gage.
9. If side clearance is not within specifications, try another piston ring set. Refer to *Engine Mechanical Specifications (LR4 VIN V)* or *Engine Mechanical Specifications (LM7 VIN T)* or *Engine Mechanical Specifications (L59 VIN Z)* or *Engine Mechanical Specifications (LQ4 VIN U)* or *Engine Mechanical Specifications (LQ9 VIN N)*.
10. If proper piston ring-to-piston ring groove side clearance cannot be achieved, replace the piston and pin assembly.



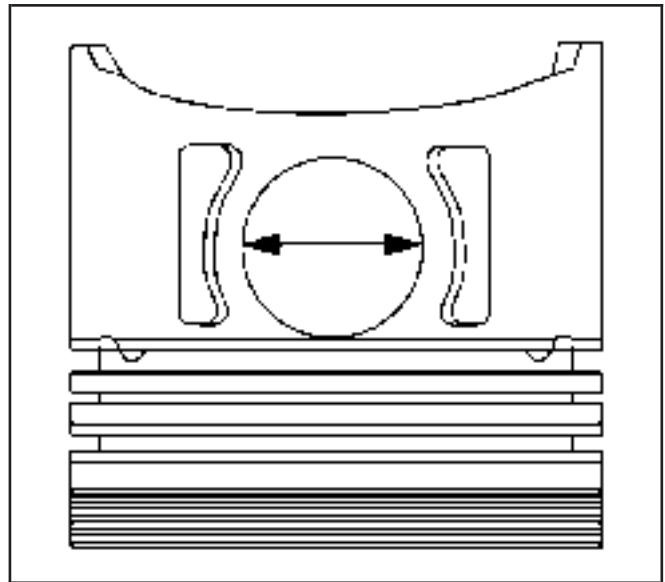
4976

11. To determine piston pin-to-bore clearance, use a micrometer and measure the piston pin.

12. To determine piston pin-to-bore clearance, use an inside micrometer and measure the piston pin bore.

Important: The piston and pin are a matched set. If the clearance is not within specifications, replace the piston and pin as an assembly.

13. To determine the proper piston pin-to-bore clearance, subtract the piston pin diameter from the piston pin bore diameter. Refer to *Engine Mechanical Specifications (LR4 VIN V)* or *Engine Mechanical Specifications (LM7 VIN T)* or *Engine Mechanical Specifications (L59 VIN Z)* or *Engine Mechanical Specifications (LQ4 VIN U)* or *Engine Mechanical Specifications (LQ9 VIN N)*.



4975

Connecting Rod and Bearings

Important: The powdered metal connecting rod and cap are machined for the proper clearances. The connecting rod and the cap must be used as an assembly with no repair or modifications to either mating surface.

Do not attempt to repair the connecting rod or the cap mating surfaces. If service is required, the connecting rod and the cap must be replaced as an assembly.

1. Clean the connecting rod and the cap in solvent.

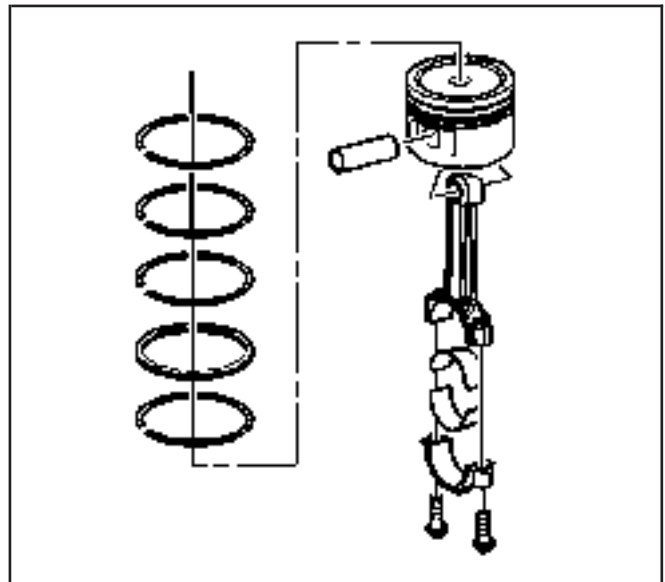
Important: Replace the connecting rod if the bolt hole threads are damaged. Do not attempt to repair the bolt hole threads of the connecting rod.

2. Clean the connecting rod threaded bolts holes.

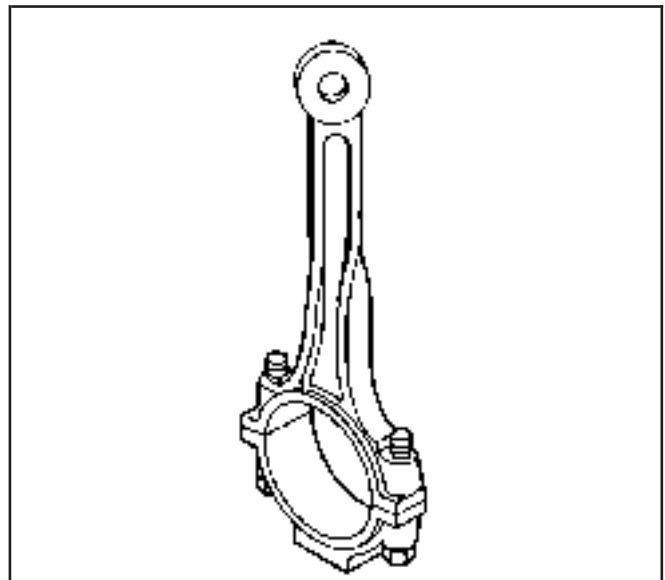
Caution: Refer to Safety Glasses Caution in Cautions and Notices.

3. Dry the connecting rod with compressed air.

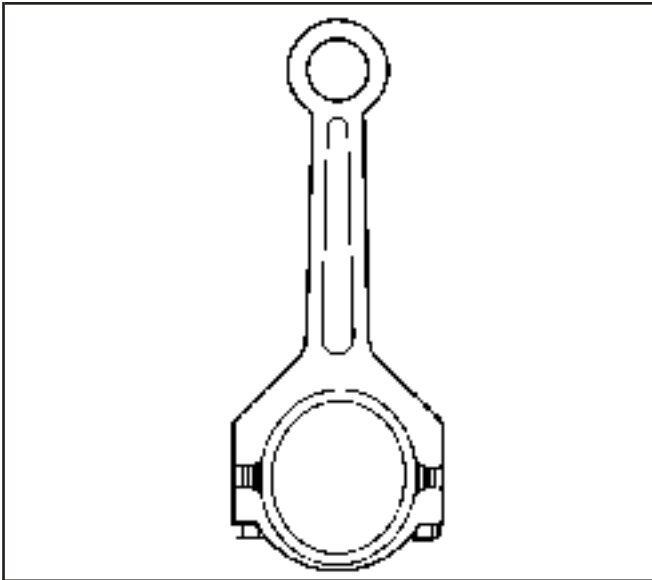
4. Inspect the connecting rod for the following:
 - Twisting
 - Nicks or gouging in the bearing bore
 - Damage to the bearing locating slots in the bearing bore
 - Proper fit of the connecting rod and the cap mating surfaces



64180

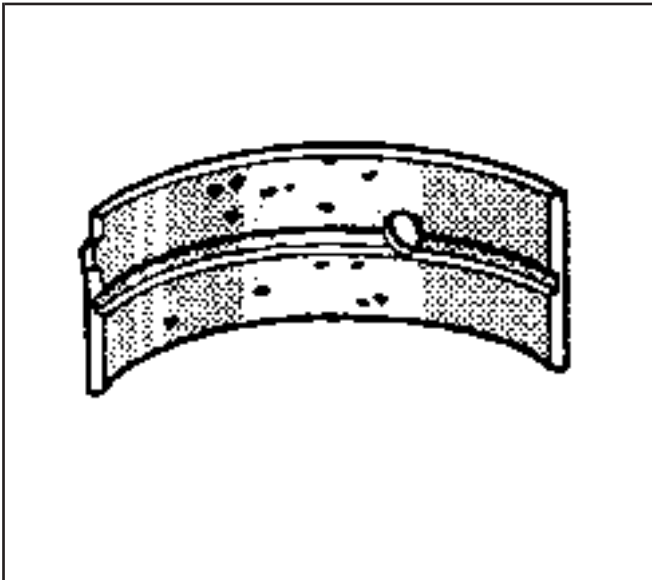


156169



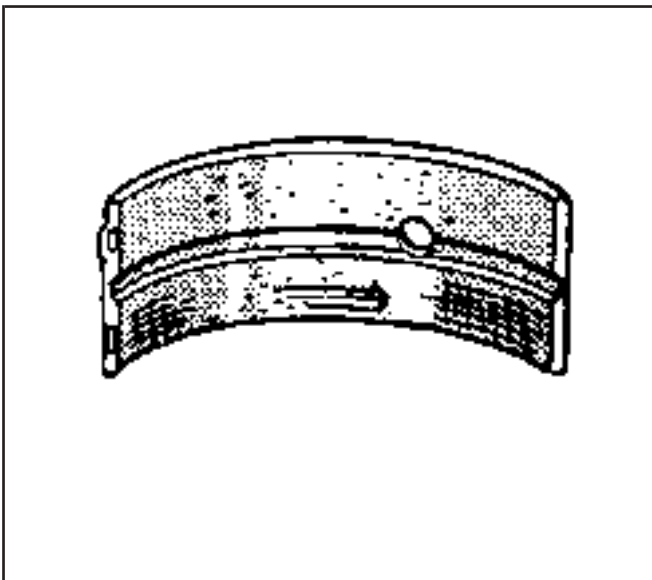
156167

5. Measure the connecting rod bearing bore for out-of-round.
If the measurement exceeds 0.008 mm (0.0003 in), replace the connecting rod assembly.



52051

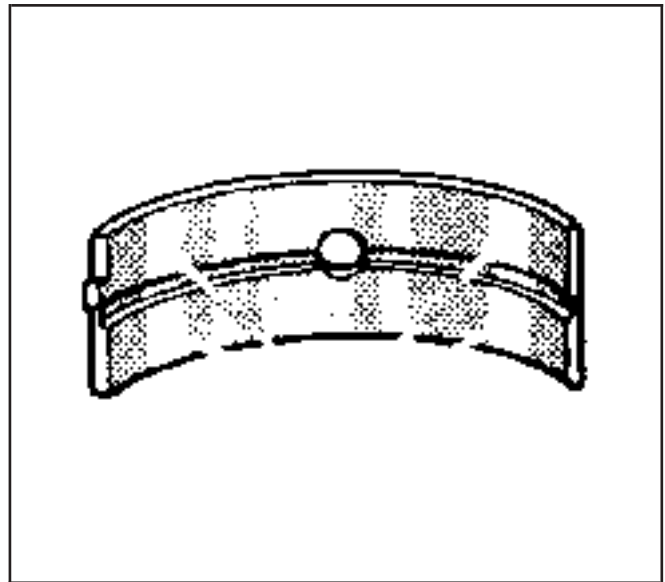
6. Inspect the connecting rod bearings for craters or pockets. Flattened sections on the bearing halves also indicate fatigue.



52053

7. Inspect the connecting rod bearings for excessive scoring or discoloration.
8. Inspect the connecting rod bearings for dirt or debris imbedded into the bearing material.

9. Inspect the connecting rod bearings for improper seating indicated by bright, polished sections of the bearing.



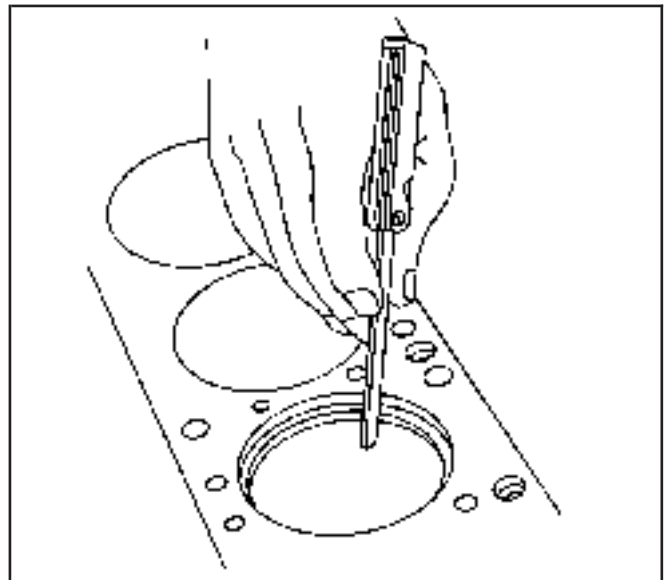
52056

Measuring Piston Ring End Gap

Important: Do not attempt to file the end of the piston ring for fit in the cylinder bore.

Important: Measure the piston ring in the cylinder in which the piston ring will be used.

1. Place the piston ring into the cylinder bore.
2. Push the piston ring into the bore 6.5 mm (0.25 in) below the piston ring travel area.
3. Insert a feeler gage and measure the piston ring end gap. Refer to *Engine Mechanical Specifications (LR4 VIN V)* or *Engine Mechanical Specifications (LM7 VIN T)* or *Engine Mechanical Specifications (L59 VIN Z)* or *Engine Mechanical Specifications (LQ4 VIN U)* or *Engine Mechanical Specifications (LQ9 VIN N)*.



4968

Piston and Connecting Rod Assemble

SIE-ID = 741681 LMD = 18-mar-2002

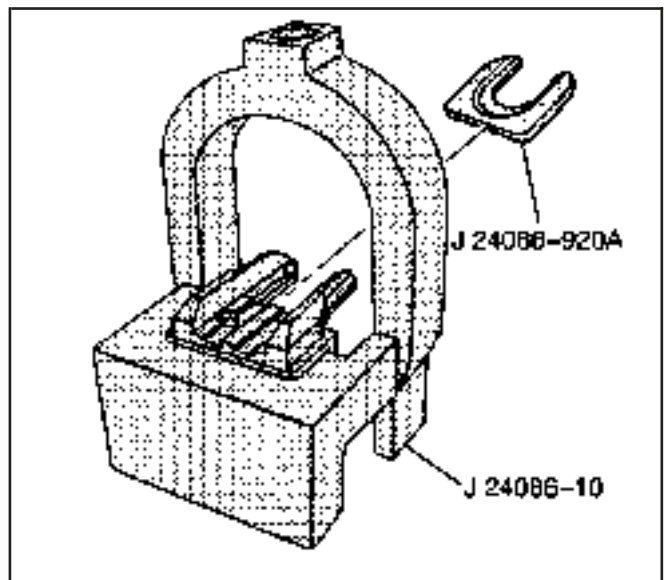
Important:

- Assemble the piston for the specific cylinder with the connecting rod for the corresponding crankshaft journal.
- Certain 6.0L LQ9 engines will use a full-floating piston and pin design. In those applications, the pin is retained in the piston by retaining clips.

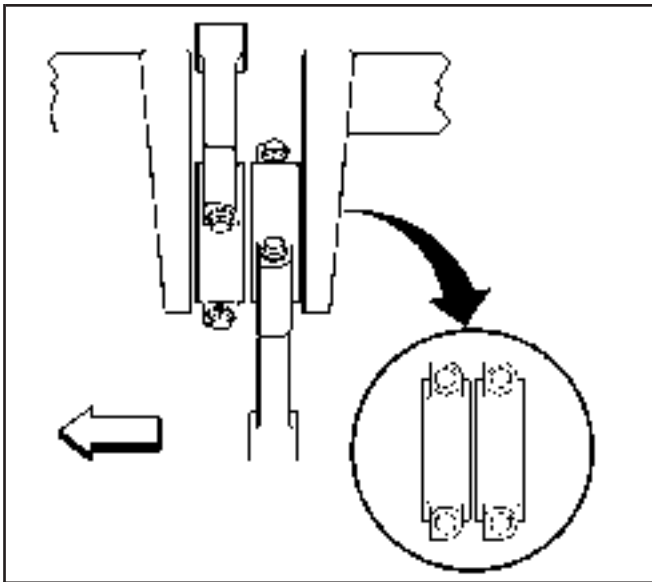
Press Fit Piston Pin

Tools Required

- J 24086-C Piston Pin Remover/Installer Set
 - J 24086-9 Adjustable Installer
 - J 24086-10 Piston Pin Remover/Installer Base
1. Install fork insert J 24086-920A into fixture J 24086-10 Piston Pin Remover/Installer Base.



533477

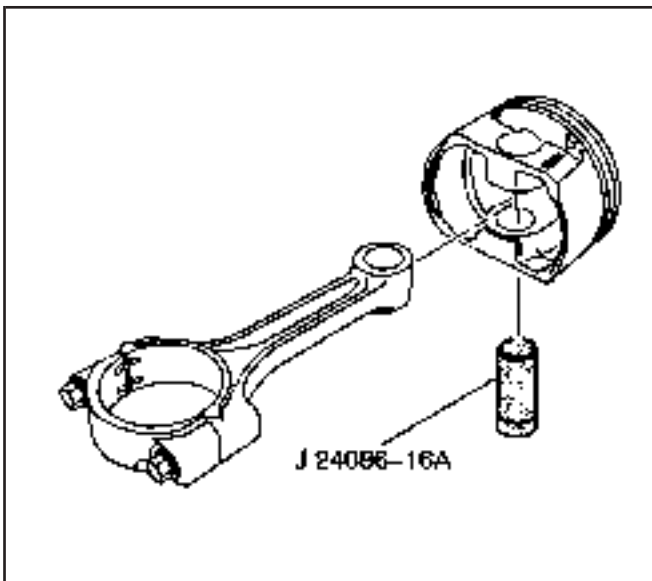


63227

Caution: SIO-ID = 71607 LMD = 13-aug-1996 **Avoid contact with HOT components. Wear safety glasses and protective gloves to avoid personal injury.**

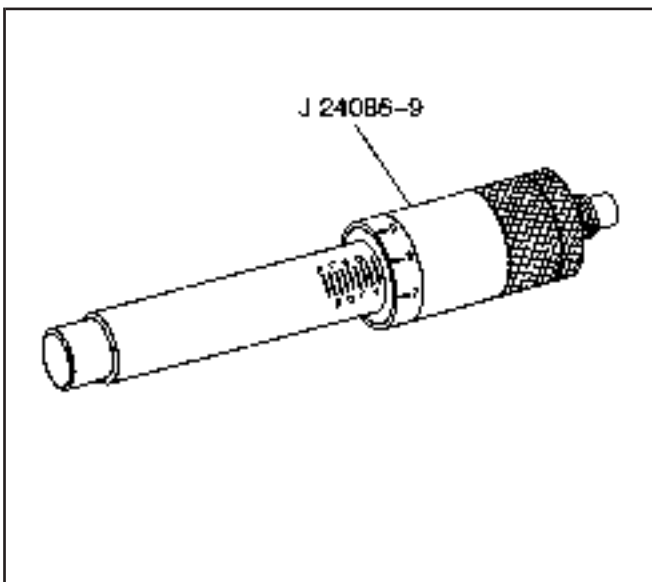
Notice: SIO-ID = 71608 LMD = 17-nov-1998 Applying excessive heat to the connecting rod may damage or distort the rod. Rod temperature **SHOULD NOT** exceed 315°C (600°F). At this temperature the end of the connecting rod will turn a straw color upon visual inspection.

2. Use a torch and apply MILD heat to the pin end of the connecting rod.
Mild heating of the connecting rod will ease in piston and pin assembly.
3. With the piston and connecting rod properly assembled, both the flat flange area of the top of the connecting rod and the alignment mark on the top of the piston will be facing the front of the engine.
4. Assemble the piston, connecting rod and adapter J 24086-16A and install onto fixture J 24086-10.



533488

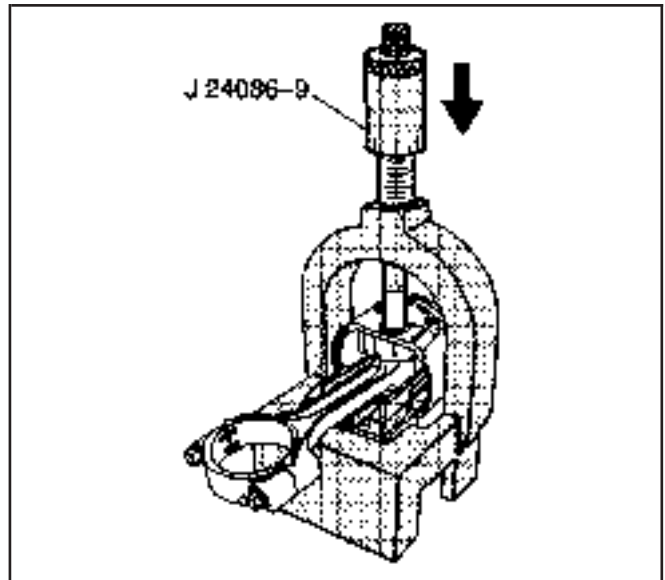
5. Adjust installation pin J 24086-9 to I-8.



533486

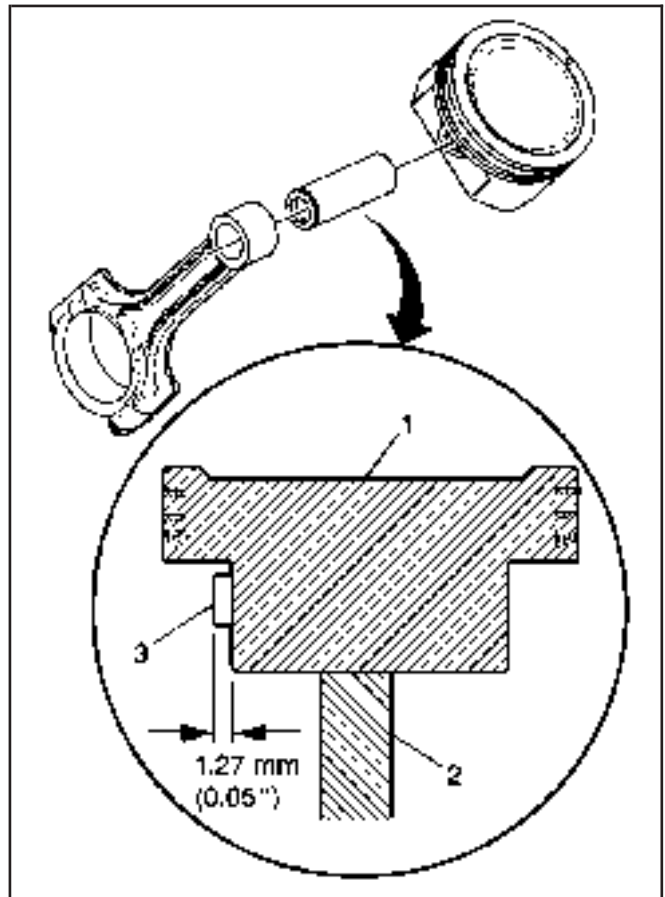
Notice: SIO-ID = 5015 LMD = 25-feb-2000 After the installer hub bottoms on the support assembly, do not exceed 35 000 kPa (5,000 psi) pressure, this could cause damage to the tool.

6. Insert pin J 24086-9 through fixture J 24086-10 and to the piston pin.
7. Press pin J 24086-9 until the installer bottoms on fixture J 24086-10.

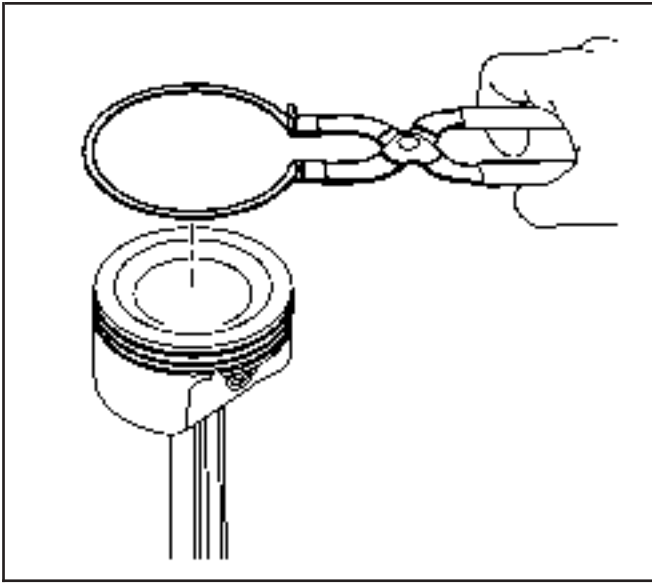


533483

8. Measure the piston (1), pin (3), and connecting rod (2) for proper assembly.
 - 8.1. Place the piston and connecting rod assembly onto a table or other flat surface.
Lay the flat top of the piston (1) onto the table surface.
 - 8.2. Slide the connecting rod (2) and pin (3) to one side and hold firmly against the inside of the piston (1).
 - 8.3. Measure the pin (3) for proper installation.
A properly installed piston pin should protrude 1.27 mm (0.05 in) from the side of the piston.



63156

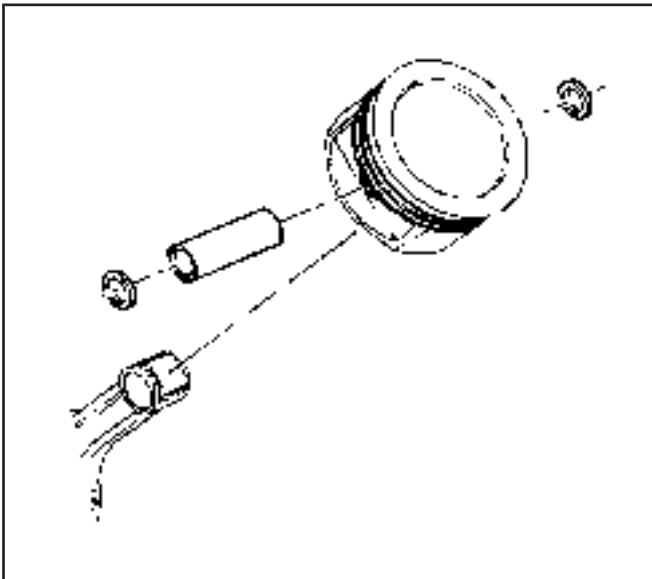


490763

Important: When installing the piston rings onto the piston, use a ring expanding plier type tool. Do not roll the piston rings into the grooves of the piston.

Use caution and care to expand the piston rings only slightly larger than the outside diameter (OD) of the piston.

9. Using piston ring pliers, install the piston rings onto the piston.
 - 9.1. Install the oil control ring spacer in the groove.
 - 9.2. Install the lower oil control ring.
The oil control rings do not have a dimple or orientation mark and may be installed in either direction.
 - 9.3. Install the upper oil control ring.
 - 9.4. Stagger the three oil control ring end gaps a minimum of 90 degrees.
 - 9.5. Using piston ring pliers, install the lower compression ring.
The lower compression ring has a dimple or orientation mark and must face the top of the piston.
 - 9.6. Using piston ring pliers, install the upper compression ring.
The upper compression ring does not have a dimple or orientation mark and may be installed in either direction.
 - 9.7. Stagger the compression ring end gaps a minimum of 25 mm (1.0 in).



35866

Full-Floating Piston Pin

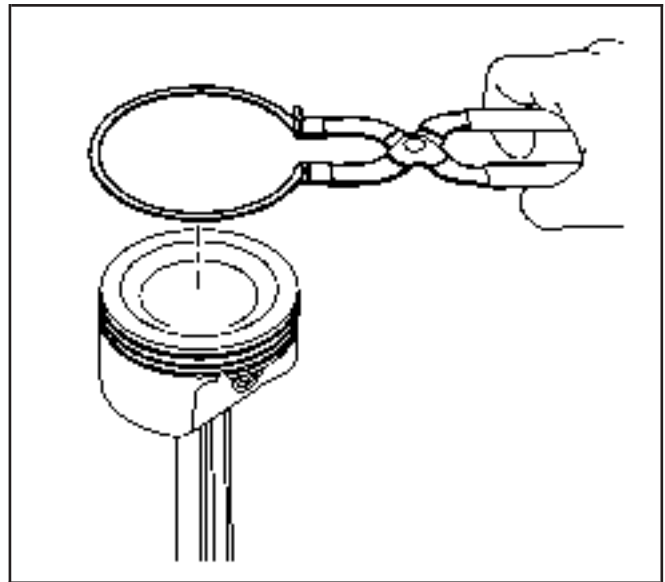
Important: With the piston and connecting rod properly assembled, both the flat flange area of the connecting rod and the alignment mark on the top of the piston will be facing the front of the engine.

1. Install the pin to the piston and connecting rod.
2. Install the retaining clips.

Important: When installing the piston rings onto the piston, use a ring expanding plier type tool. Do not roll the piston rings into the grooves of the piston.

Use caution and care to expand the piston rings only slightly larger than the outside diameter (OD) of the piston.

3. Using piston ring pliers, install the piston rings onto the piston.
 - 3.1. Install the oil control ring spacer in the groove.
 - 3.2. Install the lower oil control ring.
The oil control rings do not have a dimple or orientation mark and may be installed in either direction.
 - 3.3. Install the upper oil control ring.
 - 3.4. Stagger the three oil control ring end gaps a minimum of 90 degrees.
 - 3.5. Using piston ring pliers, install the lower compression ring.
The lower compression ring has a dimple or orientation mark and must face the top of the piston.
 - 3.6. Using piston ring pliers, install the upper compression ring.
The upper compression ring does not have a dimple or orientation mark and may be installed in either direction.
 - 3.7. Stagger the compression ring end gaps a minimum of 25 mm (1.0 in).



490763

Camshaft Bearing Removal

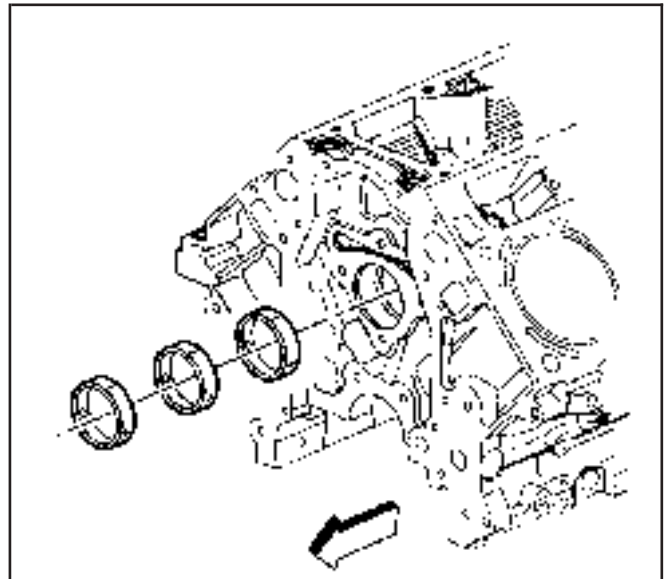
SIE-ID = 283355 LMD = 03-jun-2002

Tools Required

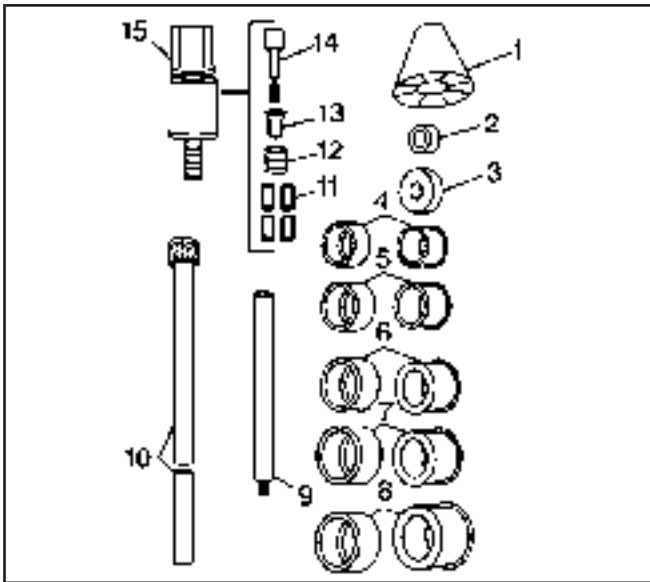
J 33049 Camshaft Bearing Service Set

Important: A loose camshaft bearing may be caused by an enlarged, out of round or damaged engine block bearing bore.

1. Prior to bearing removal, inspect the camshaft bearings for loose fit in the engine block bearing bores.
Refer to *Camshaft and Bearings Cleaning and Inspection*.
2. Repair or replace the components as required.

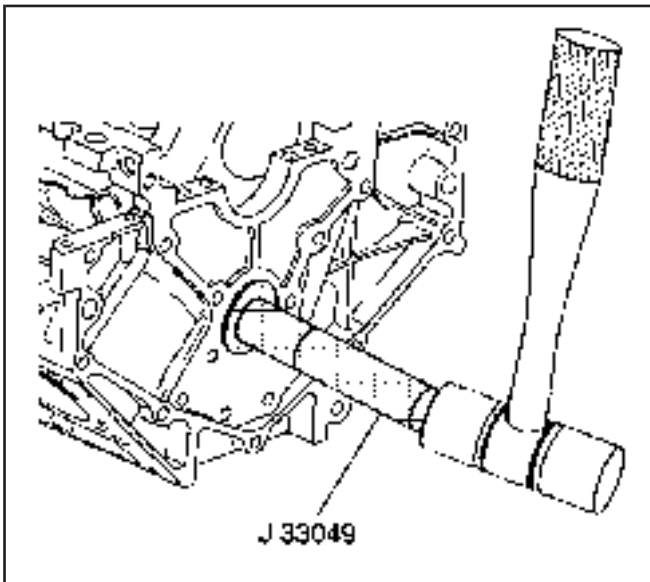


63163



66100

3. Select the expanding driver (4–8) and washer (2 or 3) from the *J 33049*.
4. Assemble the tool.
5. Insert the tool through the front of the engine block and into the bearing.
6. Tighten the expander assembly (15) nut until snug.
7. Push the guide cone (1) into the front camshaft bearing to align the tool.

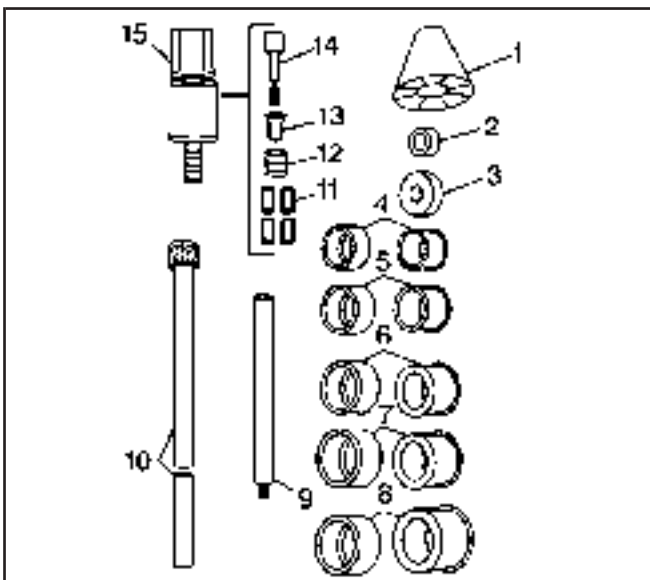


63219

8. Drive the bearing from the block bore.

Important: To remove the front camshaft bearing, operate the tool from the rear of the block using the guide cone in the rear camshaft bearing bore.

9. Repeat the above procedures to remove the remaining bearings.



66100

Tool Usage Information

Bearing, Expander, and Expander Driver Information

- The tool consists of a guide cone (1), driving washers (2 or 3), expander bearing drivers (4–8), driver bars (9 or 10), expander jaws (11), expander sleeve (12), expander cone (13), expander shaft (14), and expander assembly (15).
- Expander bearing driver number one inside diameter is 28.575–37.465 mm (1.125–1.475 in) and is used with the expander assembly and the small washer.
- Expander bearing driver number two inside diameter is 37.465–43.18 mm (1.475–1.7 in) and is used with number one expanding driver and the small washer.

- Expander bearing driver number three inside diameter is 43.18–48.895 mm (1.7–1.925 in) and is used with number two expanding driver and the large washer.
- Expander bearing driver number four inside diameter is 48.895–54.61 mm (1.925–2.15 in) and is used with number three expanding driver and the large washer.
- Expander bearing driver number five inside diameter is 54.61–60.325 mm (2.150–2.375 in) and is used with number four expanding driver and the large washer.
- Expander bearing driver number six inside diameter is 60.325–68.326 mm (2.375–2.69 in) and is used with number five expanding driver and the large washer.

Tool Assembly and Operation

1. Select the proper expanding driver and washer from the expanding driver and washer information.

Important: To install or remove the expanding driver, always push on or pull from the ends.

Pressure on the outside diameter may cause a bind against the rubber expanding sleeve.

2. Place the expanding driver onto the expander assembly.
3. Check to insure that the separation lines between the segments of the expanding driver align with the separation lines of the expander assembly.
4. Place the guide cone over the driving bar, with the small end of the cone facing the driver assembly.
5. Place the driving washer over the threaded portion of the expander assembly.
6. Screw the expander assembly, with driving washer, onto the driving bar.

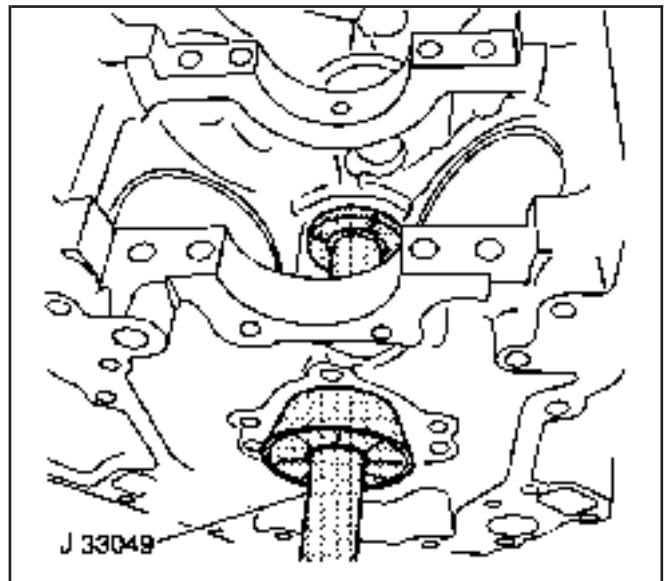
It may be necessary to install the driver bar extension for removal of the inner bearings.

7. Insert the tool into a inner camshaft bearing and tighten until snug.

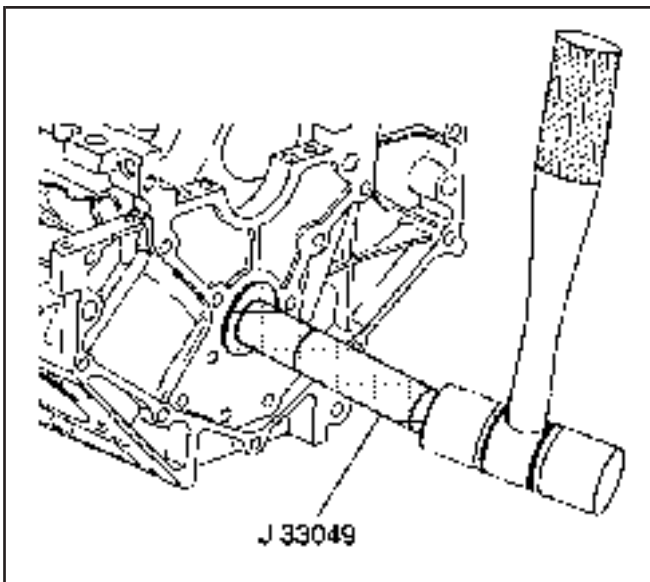
Operate the tool from the front or rear of the engine block.

On some engine blocks the nut on the expander assembly is inaccessible except from either end. In this case you must use a socket and extension to enlarge and reduce the expander assembly.

8. Slide the nylon cone into the front or rear camshaft bearing. This will properly align the tool.
9. Drive the bearing out of or into the engine block.
10. Repeat the procedure for the additional inner bearings.

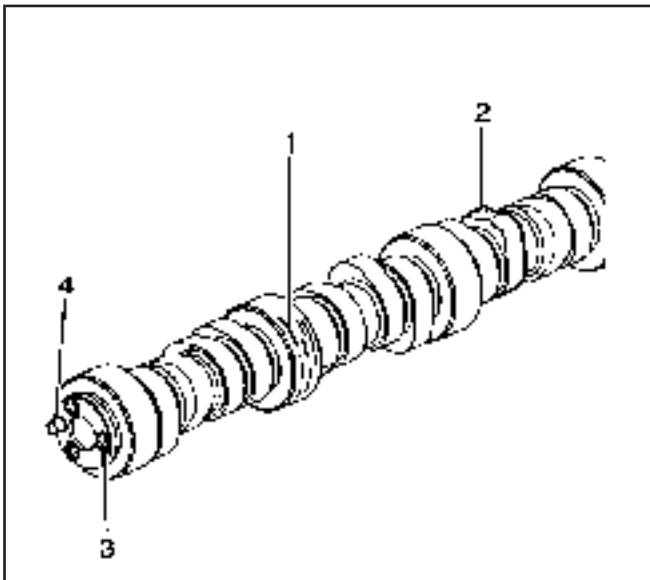


64183



63219

11. For the two end bearings, front and rear, remove the nylon cone and driver bar extension.
12. Drive the bearings out of or into the engine block.



188095

Camshaft and Bearings Cleaning and Inspection

SIE-ID = 644038 LMD = 18-mar-2002

Tools Required

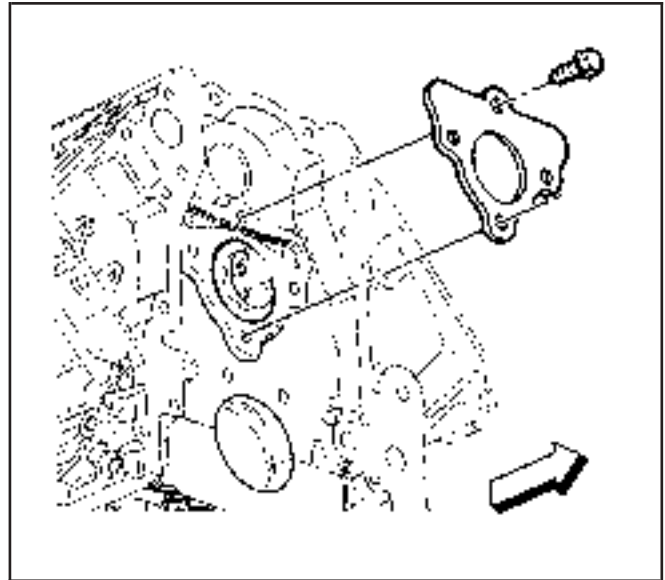
- J 7872 Magnetic Base Dial Indicator Set
- J 8520 Camshaft Lobe Lift Indicator

1. Clean the components in solvent.

Caution: Refer to Safety Glasses Caution in Cautions and Notices.

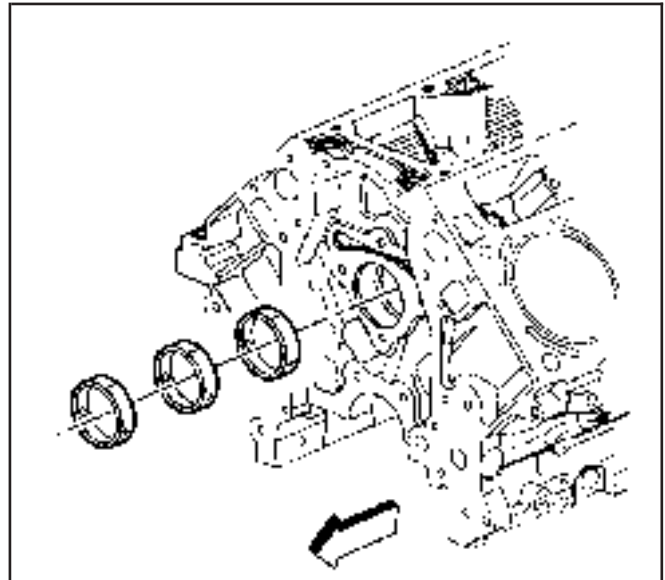
2. Dry the components with compressed air.
3. Inspect the camshaft bearing journals (1) for scoring or excessive wear.
4. Inspect the camshaft valve lifter lobes (2) for scoring or excessive wear.
5. Inspect the threaded bolt holes (3) in the front of the camshaft for damaged threads or debris.
6. Inspect the camshaft sprocket pin (4) for damage.
7. Inspect the camshaft position reluctor ring for nicks or damage.

8. Inspect the camshaft retainer plate for wear or a damaged sealing gasket.
If the camshaft retainer plate sealing gasket is not cut or damaged, it may be used again.



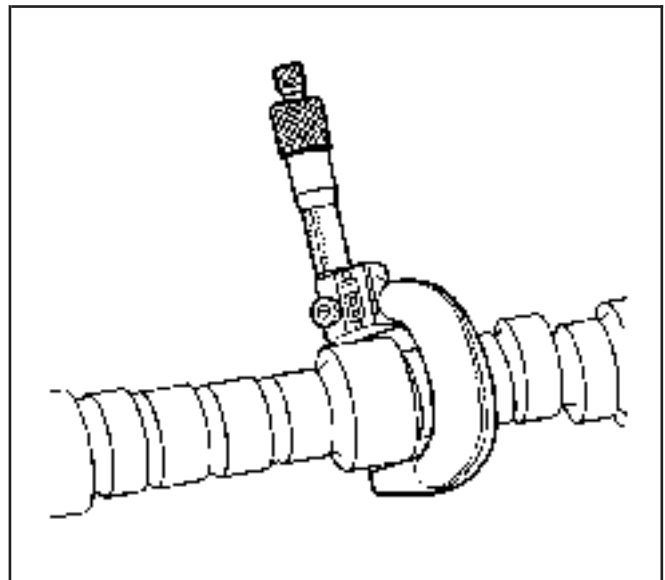
63211

9. Inspect the camshaft bearings for proper fit in the engine block. Camshaft bearings have an interference fit to the engine block and should not be loose in their engine block bearing bores.
10. Inspect the camshaft bearings for excessive wear or scoring.
Bearings with excessive scoring or wear must be replaced.

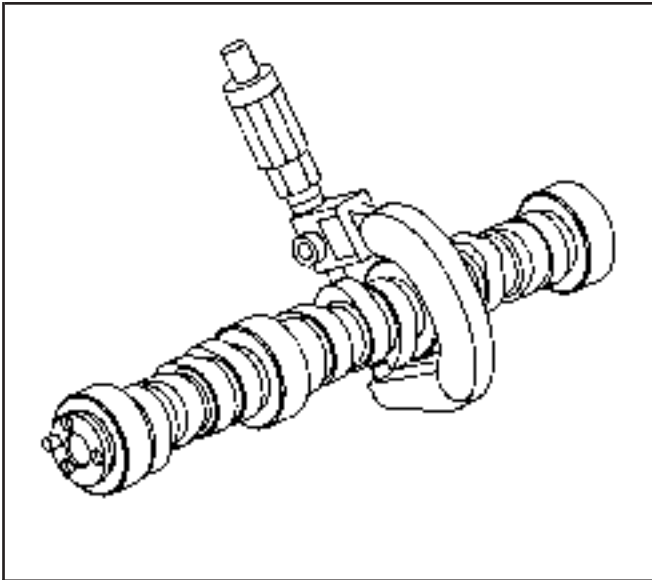


63163

11. Measure the camshaft journals for wear and out-of-round with a micrometer.
 - If the camshaft bearing journals are more than 0.025 mm (0.001 in) out-of-round, replace the camshaft.
 - If the camshaft bearing journal diameter is less than 54.99 mm (2.164 in), replace the camshaft.



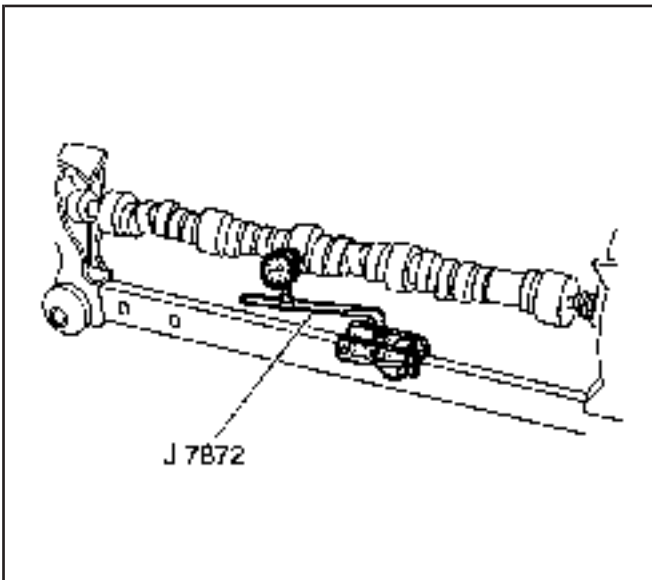
35212



260130

12. Measure the camshaft lobes for wear with a micrometer.

- A 4.8/5.3L camshaft with an intake lobe that measures 46.169 mm (1.817 in) or less must be replaced.
- A 4.8/5.3L camshaft with an exhaust lobe that measures 46.199 mm (1.818 in) or less must be replaced.
- A 6.0L camshaft with an intake lobe that measures 46.31 mm (1.823 in) or less must be replaced.
- A 6.0L camshaft with an exhaust lobe that measures 46.31 mm (1.823 in) or less must be replaced.



64297

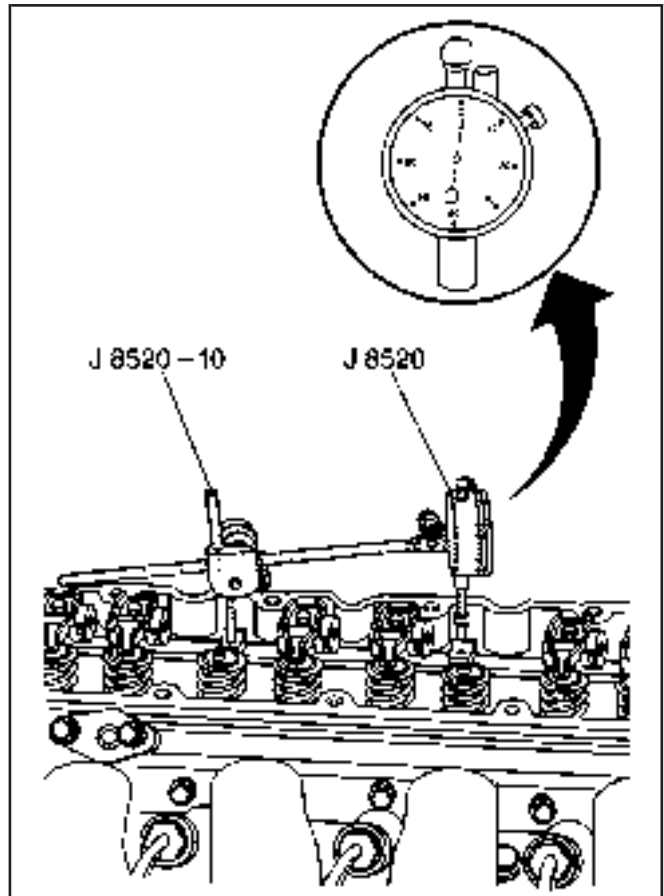
13. Measure the camshaft runout.

- 13.1. Mount the camshaft in wooden V blocks or between centers on a fixture.
- 13.2. Check the runout of the intermediate camshaft bearing journals using the *J 7872*.
- 13.3. If camshaft runout exceeds 0.05 mm (0.002 in), the camshaft is bent and should be replaced.

Measuring Camshaft Lobe Lift

Important: Measuring camshaft lobe lift is a procedure used to determine if the camshaft lobes have worn. This test is to be performed prior to engine disassembly and with the camshaft and valve train components installed in the engine.

1. Measure camshaft lobe lift using *J 8520*.
2. Remove the valve rocker arms and bolts
3. Install the dial indicator mounting stud into the valve rocker arm bolt hole.
4. Assemble the components of the *J 8520* and position onto the stud.
5. Position the shaft of the dial indicator onto the end of the pushrod.
6. Rotate the face of the dial indicator to zero.
7. Slowly rotate the crankshaft clockwise until the dial indicator obtains its highest and lowest readings.
8. Compare the total lift shown to specifications:
 - The proper lobe lift for 4.8/5.3L intake lobes is 6.82 mm (0.268 in).
 - The proper lobe lift for 4.8/5.3L exhaust lobes is 6.96 mm (0.274 in).
 - The proper lobe lift for 6.0L intake lobes is 6.96 mm (0.274 in).
 - The proper lobe lift for 6.0L exhaust lobes is 7.13 mm (0.281 in).



64967

Camshaft Bearing Installation

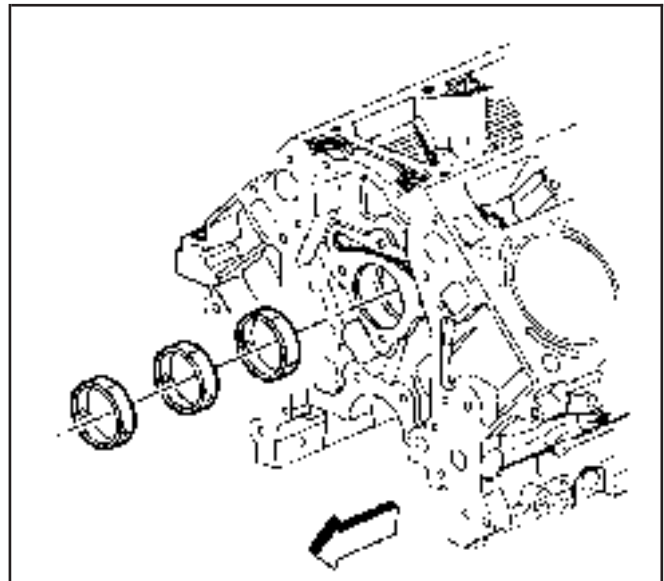
SIE-ID = 281888 LMD = 03-jun-2002

Tools Required

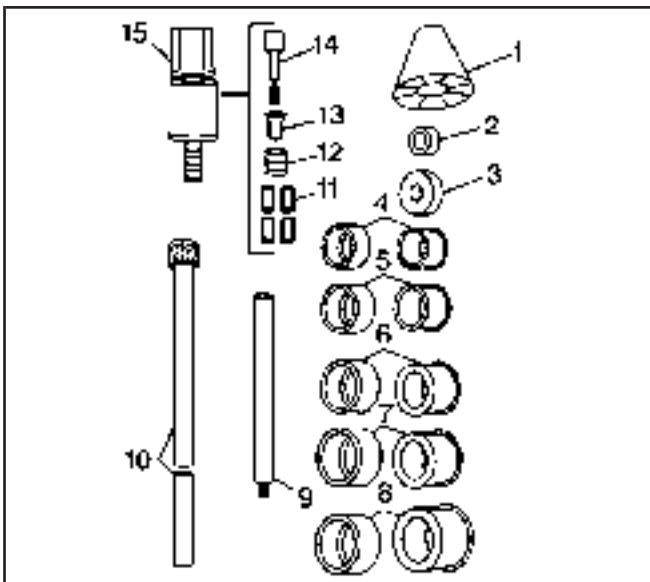
J 33049 Camshaft Bearing Service Set

Important: A loose camshaft bearing may be caused by an enlarged, out of round or damaged engine block bearing bore.

1. Prior to bearing removal, inspect the camshaft bearings for loose fit in the engine block bearing bores.
2. Repair or replace the components as required.

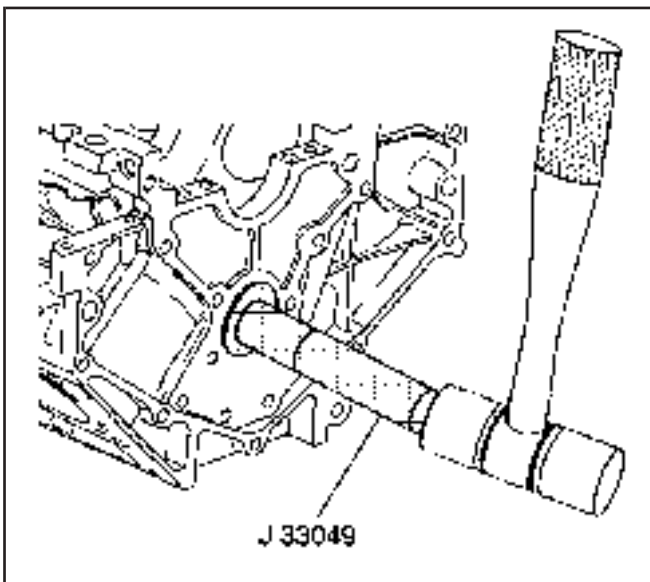


63163



66100

3. Select the expanding driver (4–8) and washer (2 or 3) from the J 33049. Refer to *Camshaft Bearing Removal*.
4. Assemble the tool.

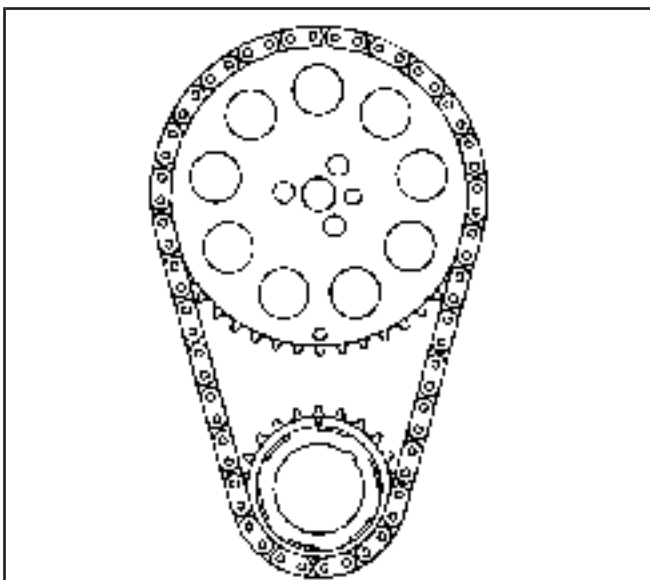


63219

5. Insert the tool through the front of the engine block and into the bearing.
6. Tighten the expander assembly nut until snug.
7. Push the guide cone into the front camshaft bearing to align the tool.
8. Drive the bearing from the block bore.

Important: To remove the front camshaft bearing, operate the tool from the rear of the block using the guide cone in the rear camshaft bearing bore.

9. Repeat the above procedures to remove the remaining bearings.



156158

Timing Chain and Sprockets Cleaning and Inspection

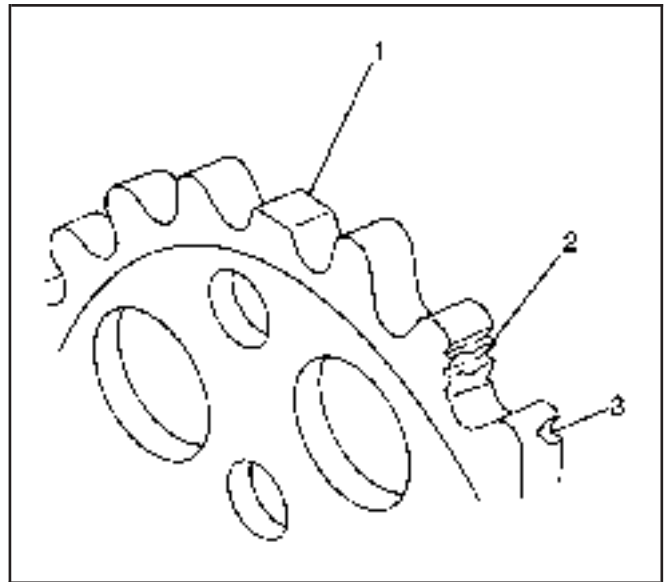
SIE-ID = 186362 LMD = 23-aug-2001

1. Clean the components with cleaning solvent.

Caution: Refer to *Safety Glasses Caution in Cautions and Notices*.

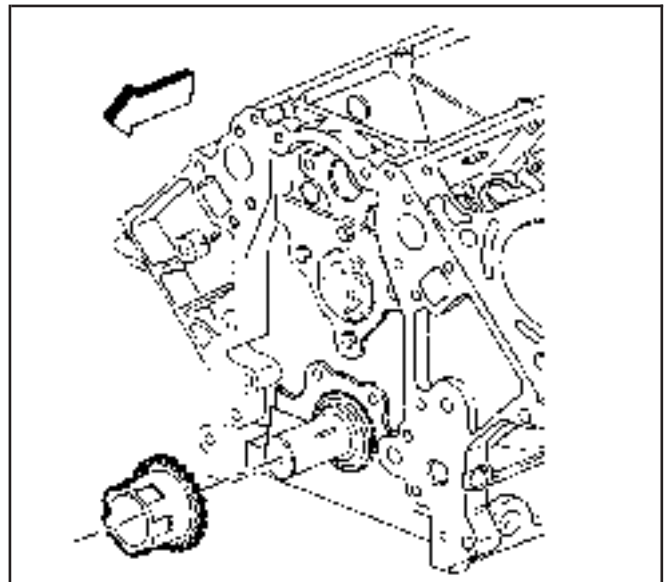
2. Dry the components with compressed air.
3. Inspect the timing chain for binding or wear.

4. Inspect the camshaft and crankshaft sprockets for:
 - Worn teeth (1)
 - Damaged teeth (2)
 - Chipped teeth (3)
 - Worn valleys between the sprocket teeth



188097

5. Inspect the crankshaft sprocket keyway for wear.
6. Inspect the crankshaft sprocket oil pump drive splines for wear.



156150

Valve Rocker Arm and Push Rods Cleaning and Inspection

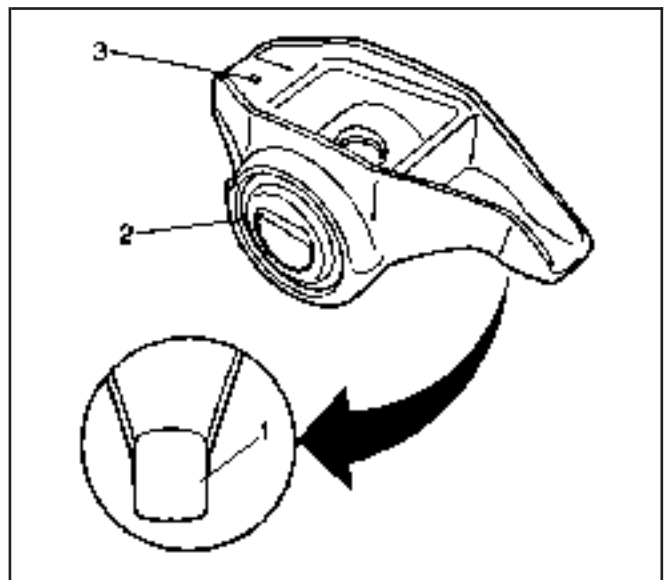
SIE-ID = 797192 LMD = 05-apr-2002

Important: Parts that are to be used again must be marked, sorted or organized for assembly.

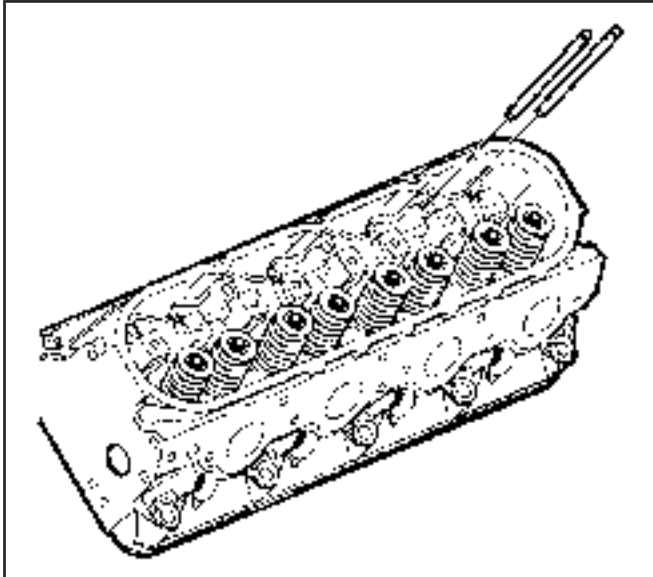
1. Mark, sort, or organize the components for assembly. Refer to *Separating Parts*.
2. Clean the components with cleaning solvent.

Caution: Refer to Safety Glasses Caution in Cautions and Notices.

3. Dry the components with compressed air.
4. Inspect the valve rocker arms bearings (2) for binding or roughness.

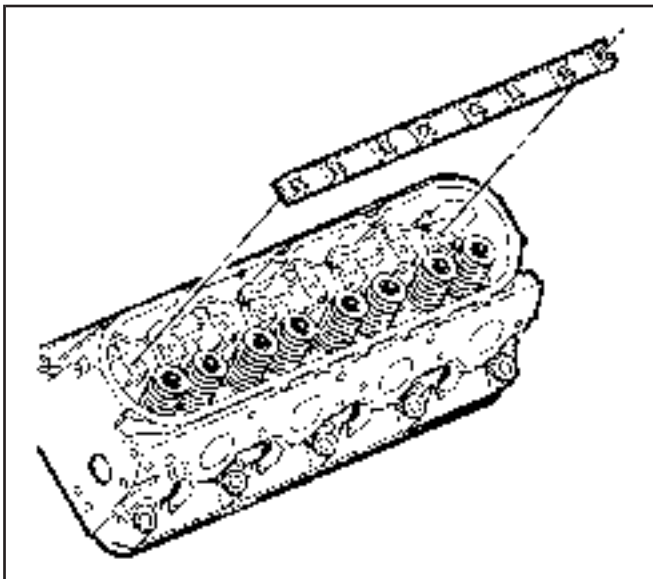


490772



260142

5. Inspect the valve rocker arm pushrod sockets (3) and valve stem mating surfaces (1). These surfaces should be smooth with no scoring or exceptional wear.
6. Inspect the pushrods for worn or scored ends. These surfaces should be smooth with no scoring or exceptional wear.
7. Inspect the pushrods for bends. Roll the pushrod on a flat surface to determine if the pushrod is bent.
8. Inspect the pushrod oil passages for restrictions.



260141

9. Inspect the pivot supports for cracks, wear, or other damage.

Valve Lifters and Guides Cleaning and Inspection

SIE-ID = 869804 LMD = 10-jun-2002

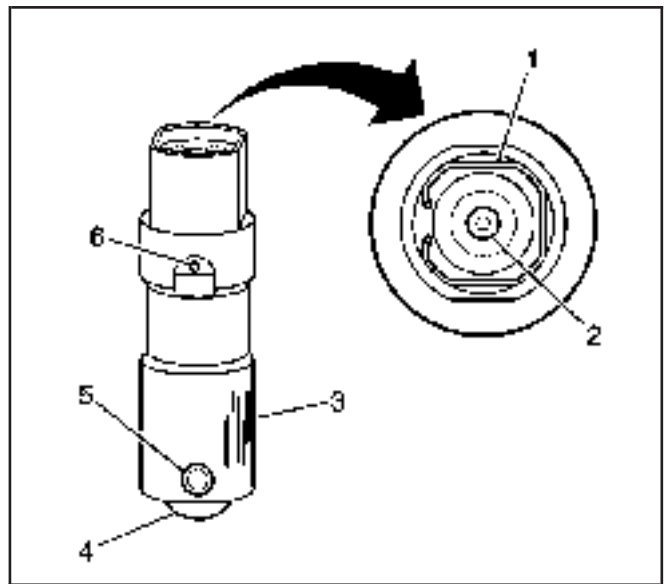
Important: Components that are to be used again must be marked, sorted or organized for assembly.

1. Mark, sort, or organize the components for assembly. Refer to *Separating Parts*.
2. Clean the components in cleaning solvent.

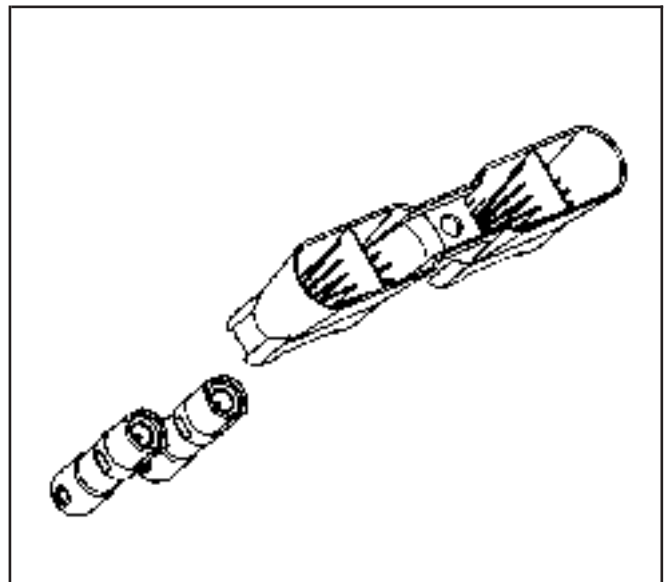
Caution: Refer to *Safety Glasses Caution in Cautions and Notices*.

3. Dry the components with compressed air.
4. Inspect the valve lifters for the following:
 - Bent or broken clip (1)
 - Worn pushrod socket (2)
 - Scuffed or worn sides (3)
 - Flat spots on the roller (4)
 - Loose or damaged pin (5)
 - Plugged oil hole (6)
 - Worn or damaged roller bearing

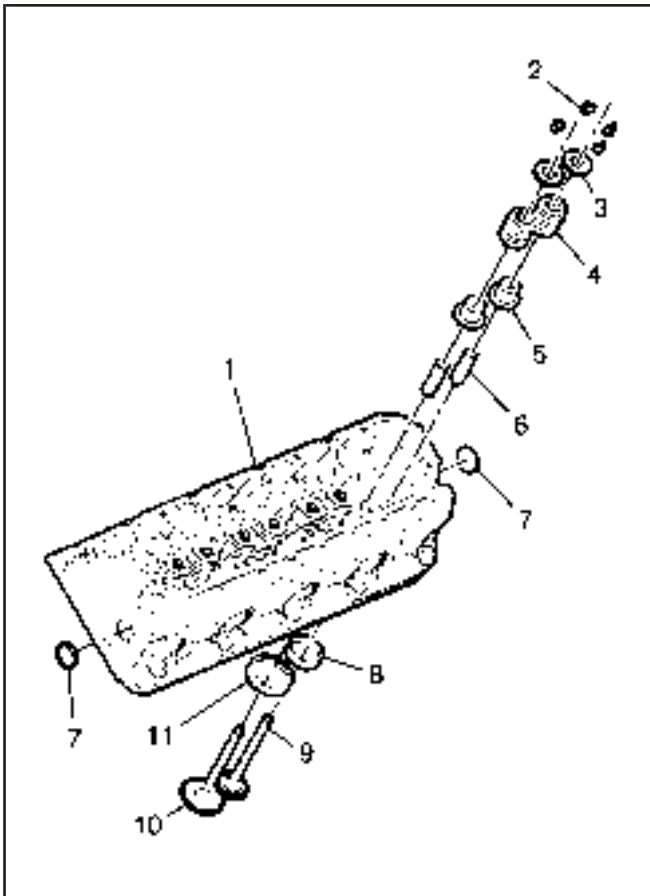
If the valve lifter shows wear, inspect the engine block lifter bores for wear or damage.
5. Inspect the valve lifter guides for the following:
 - For cracks or damage
 - Excessive wear in the lifter mounting bores



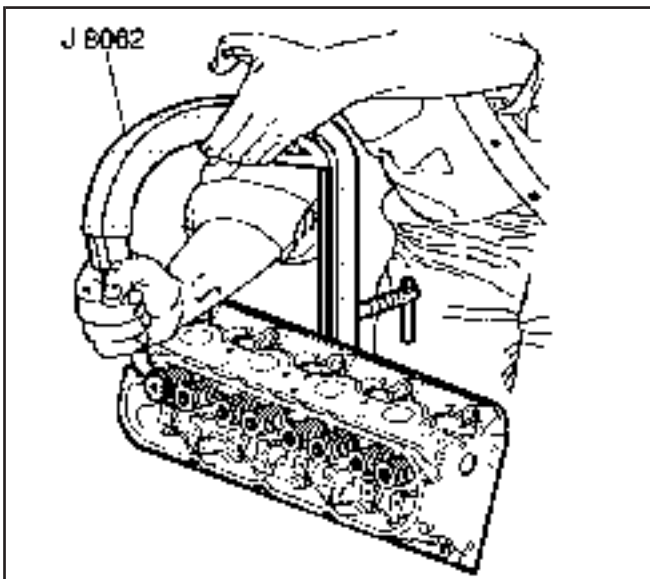
178485



63233



822537



260151

Cylinder Head Disassemble

SIE-ID = 823828 LMD = 16-jan-2002

Tools Required

J 8062 Valve Spring Compressor-Head Off

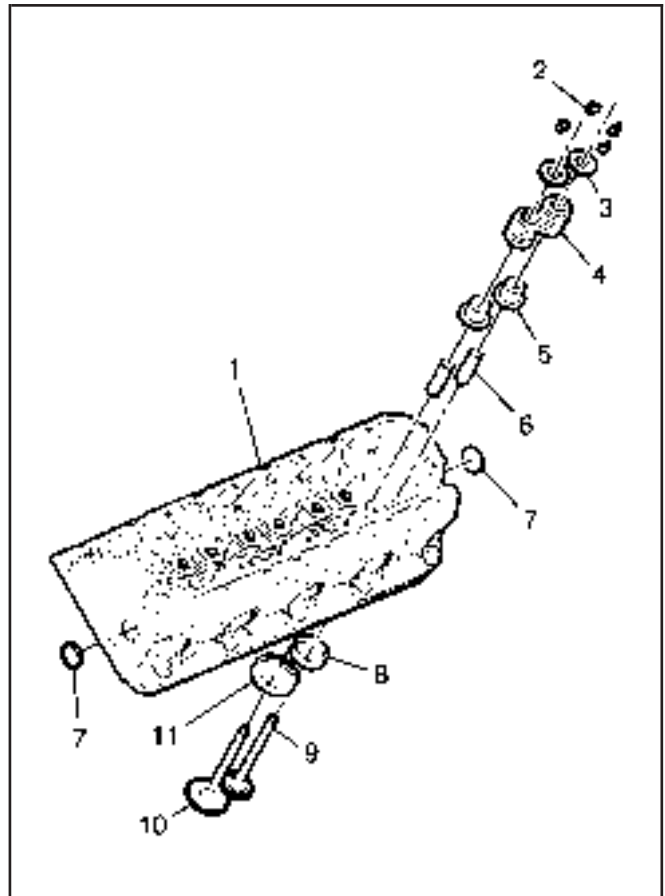
Important:

- Remove the spark plugs from the cylinder head with the components at room temperature.
- Mark, organize, or sort the cylinder head components for assembly. Return the components to their original location during assembly.
- Do not remove the cylinder head expansion plugs (7), unless service is required.

1. Remove the spark plugs from the cylinder heads.

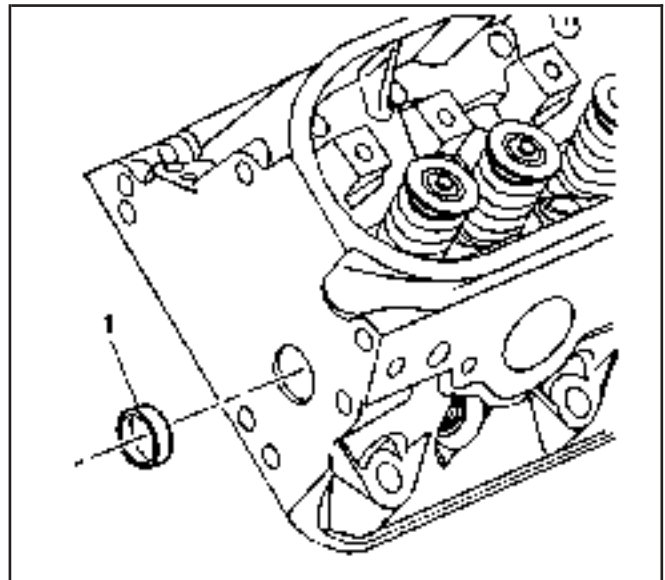
2. Use the *J 8062* in order to compress the valve spring.

3. Remove the valve stem keys (2).
4. Remove the valve spring cap (3).
5. Remove the valve spring (4).
6. Remove the valves (9 and 10).
7. Remove the valve stem oil seal and shim assembly (5). Refer to *Separating Parts*.

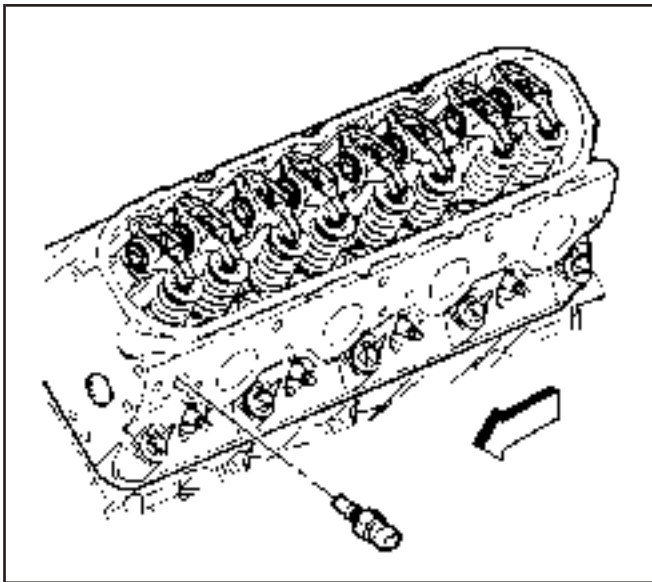


822537

8. Remove the cylinder head expansion plugs (1), if required.

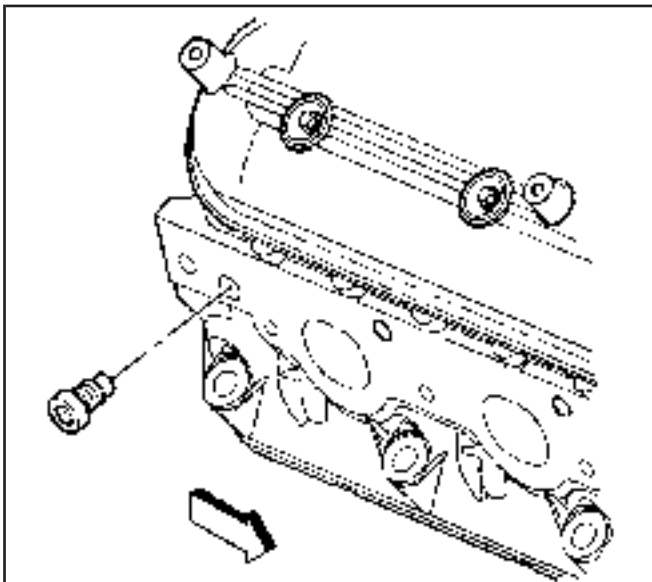


490662



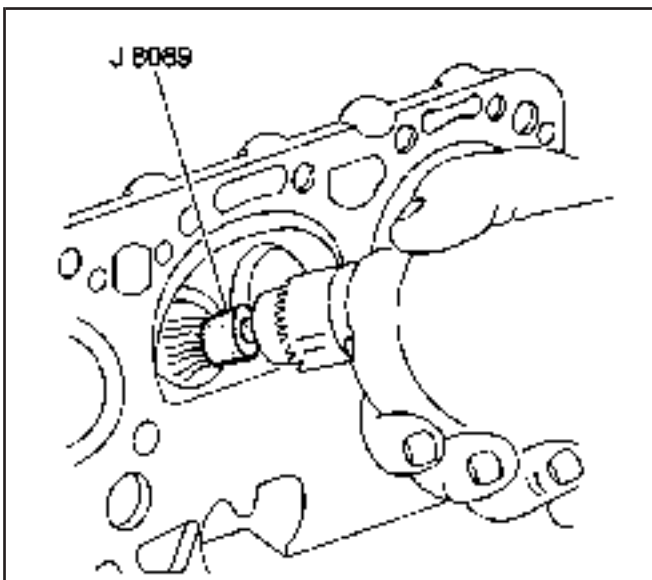
260086

9. Remove the coolant sensor from the left cylinder head, if required.



260157

10. Remove the coolant plug from the right cylinder head, if required.



4957

Cylinder Head Cleaning and Inspection

SIE-ID = 823830 LMD = 10-jun-2002

Tools Required

- J 8089 Carbon Removal Brush
- J 9666 Valve Spring Tester

Important: When cleaning a cylinder head in a thermal type oven, do not exceed 204°C (400°F).

1. Clean the following components:

Caution: Refer to *Safety Glasses Caution in Cautions and Notices*.

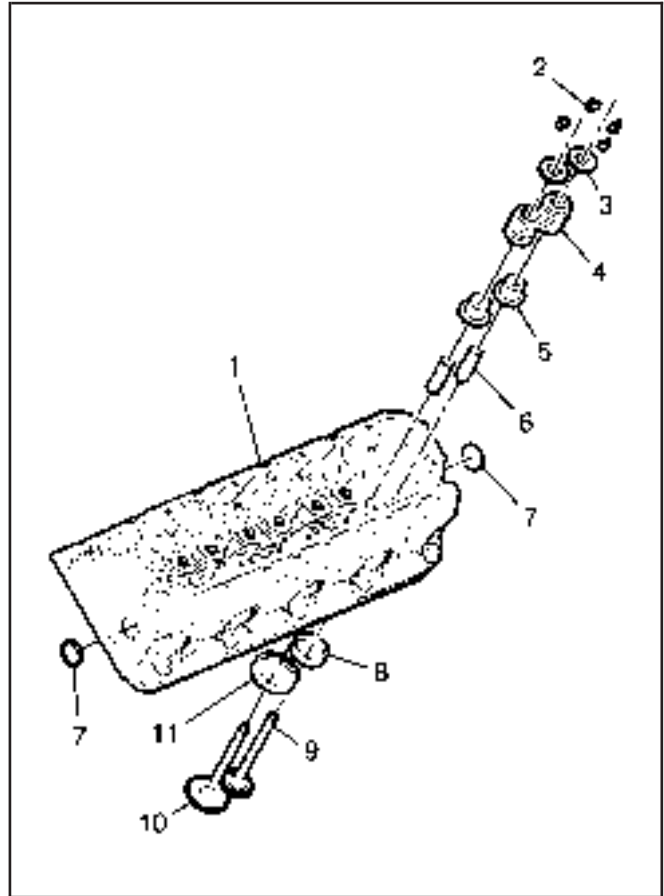
Important: Be careful not to scuff the chamber.

- Use the J 8089 in order to remove the carbon from the combustion chambers.
- Gasket surfaces
Refer to *Replacing Engine Gaskets*.
- Valve stems and heads on a buffing wheel

- Bolt hole threads
Remove all dirt, debris, or threadlocking material from the bolt holes.

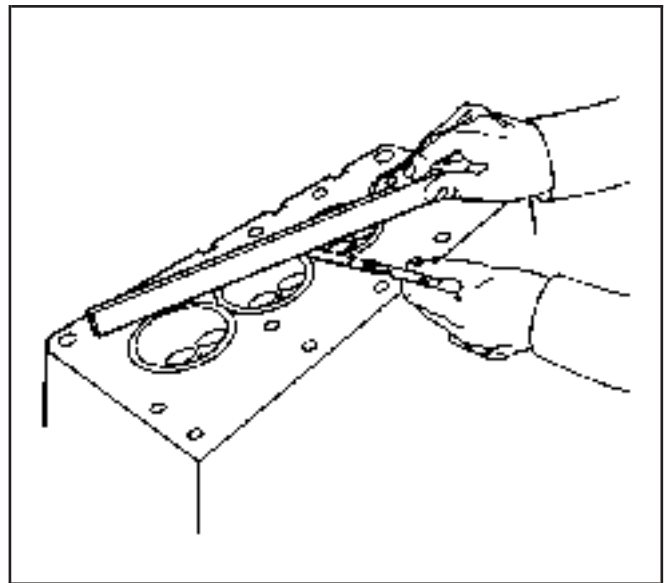
2. Inspect the following:

- 2.1. Worn or loose valve seats (8 or 11)
- 2.2. The cylinder head for cracks in the exhaust ports and combustion chambers
- 2.3. The cylinder head for external cracks in the water chambers
- 2.4. The gasket surfaces for excessive scratches or gouging
Refer to *Replacing Engine Gaskets*.
- 2.5. The bolt hole threads for debris or damaged threads
Refer to *Thread Repair* or *Thread Repair Specifications*.

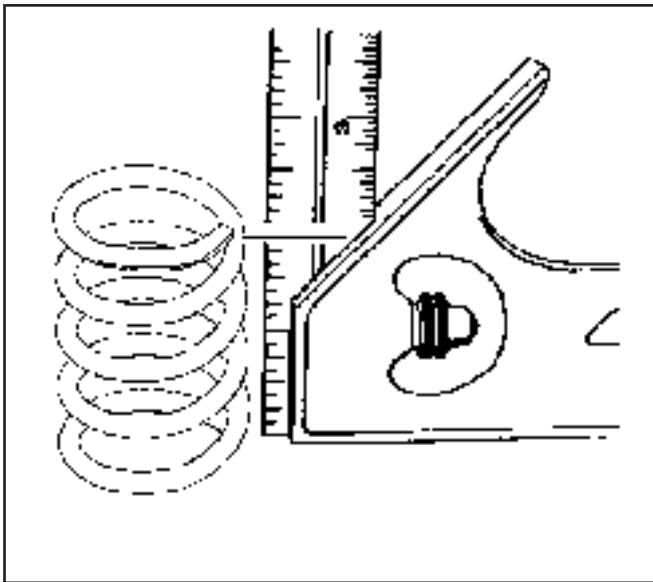


822537

3. Inspect the cylinder head for warpage. Refer to *Engine Mechanical Specifications (LR4 VIN V)* or *Engine Mechanical Specifications (LM7 VIN T)* or *Engine Mechanical Specifications (L59 VIN Z)* or *Engine Mechanical Specifications (LQ4 VIN U)* or *Engine Mechanical Specifications (LQ9 VIN N)*.

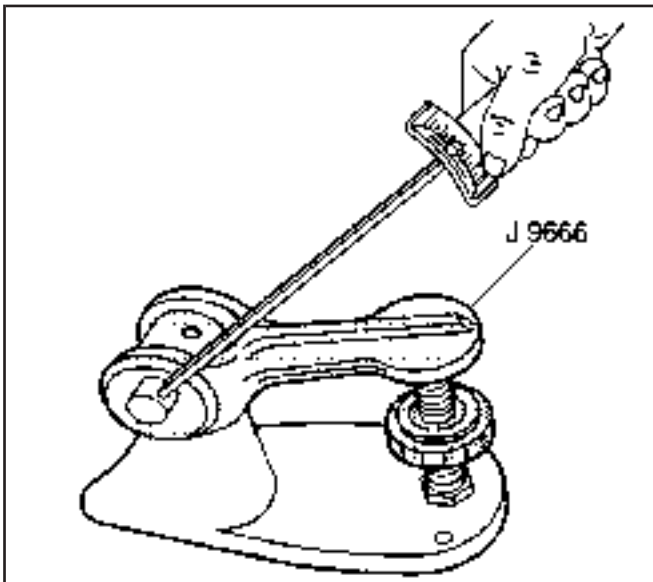


64318



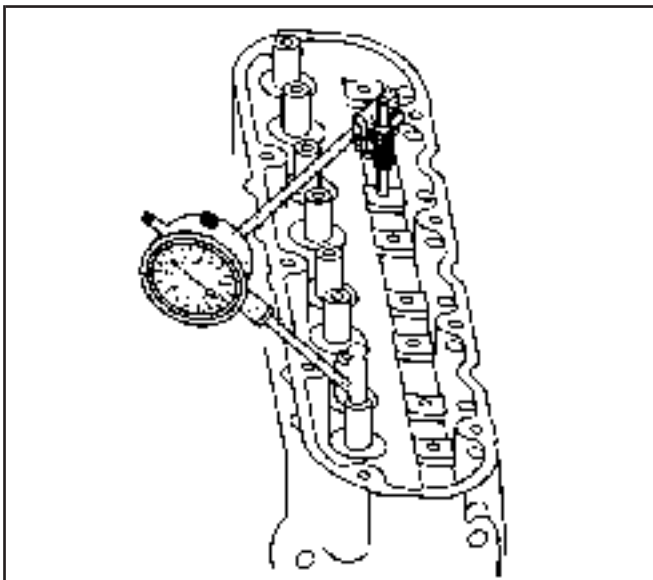
40075

4. Inspect the valve springs for squareness.



4960

5. Use the *J 9666* in order to measure the valve spring tension.
Replace the spring if the spring tension is less than 310 N (70 lb) at 45.75 mm (1.80 in).



65822

Valve Guide Reaming/Valve and Seat Grinding

SIE-ID = 823833 LMD = 16-jan-2002

Tools Required

J 37378-1 Valve Guide Reamer

Valve Guide Reaming

Important:

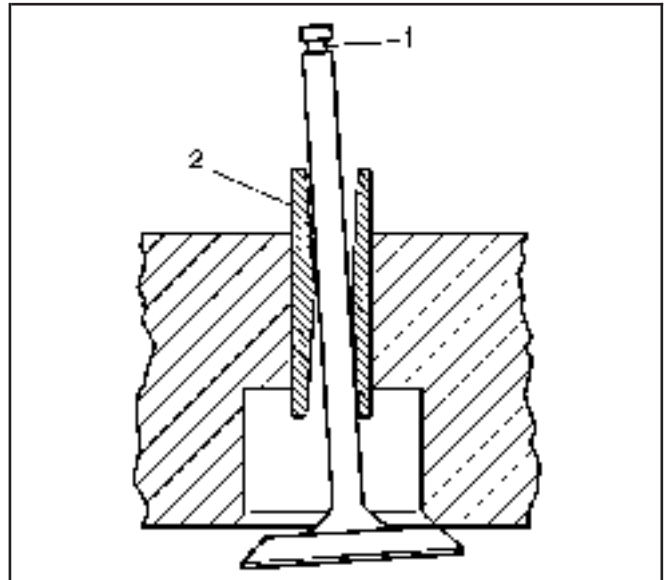
- Excessive valve stem-to-guide clearance may cause a noisy valve train, premature valve stem oil seal wear, component damage, and/or excessive engine oil consumption.
- Insufficient valve stem-to-guide clearance will result in noisy or sticking valves. Valves that are too tight may disturb engine smoothness or lead to component damage.

1. Measure the valve stem-to-guide clearance using a dial indicator. Position the tip of the dial indicator at the top of the valve guide.

Valve stem-to-guide clearance may also be obtained by using a micrometer to measure the valve stem diameter and a ball type measuring gage to measure the guide bore.

2. A valve stem (1) and guide (2) with excessive clearance must be replaced or the components replaced.

Refer to *Engine Mechanical Specifications (LR4 VIN V)* or *Engine Mechanical Specifications (LM7 VIN T)* or *Engine Mechanical Specifications (L59 VIN Z)* or *Engine Mechanical Specifications (LQ4 VIN U)* or *Engine Mechanical Specifications (LQ9 VIN N)*.



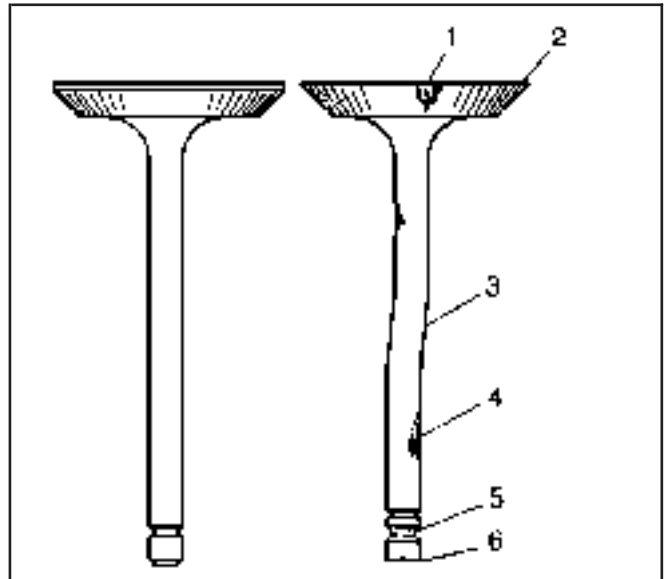
156172

3. Inspect the valve stems for excessive scoring, wear, or warpage.

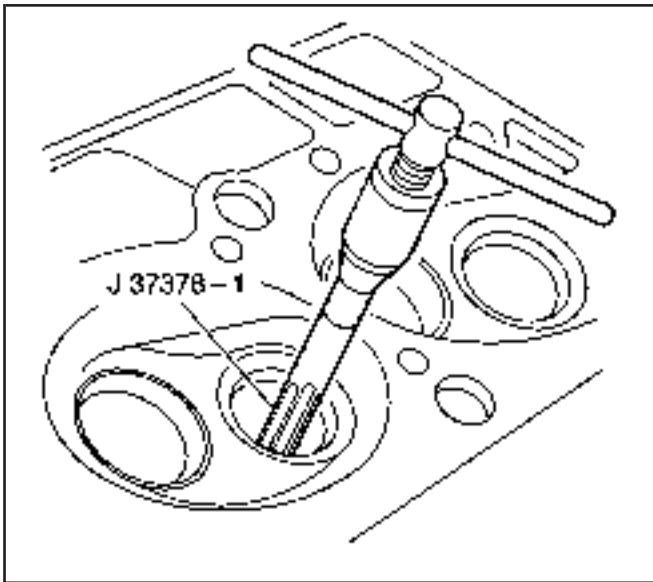
- A valve stem that has excessive scoring (3 or 4) or wear (4 or 6) must be replaced.
- A valve guide that is worn and has excessive stem-to-guide clearance should be reamed and valves with oversize stems installed.

4. Measure the valve stem diameter. A valve stem with a diameter less than 7.95 mm (0.313 in) must be replaced.

If the valve stem diameter is within specifications, and the stem-to-guide clearance is excessive, the valve guide must be reamed oversize and a valve with oversize stem installed.

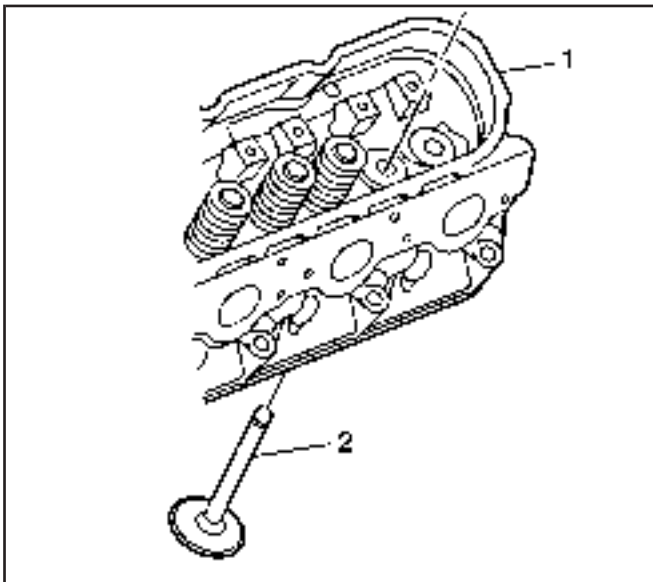


156174



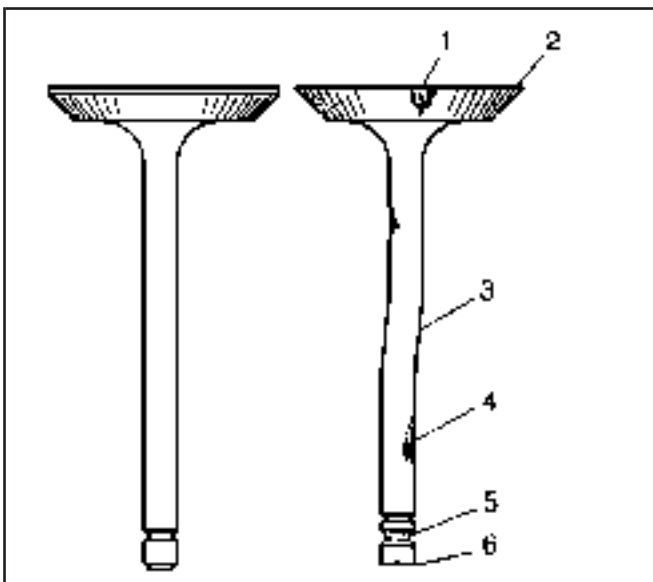
572270

5. Ream the valve guide using the *J 37378-1*.
6. Clean the guide bore of all metal shavings and debris.



572278

7. Install the valve (2), with oversize stem, into the cylinder head (1).
8. Inspect the valve for the proper fit. Move the valve back and forth in the guide. The valve should move freely with no resistance or drag.



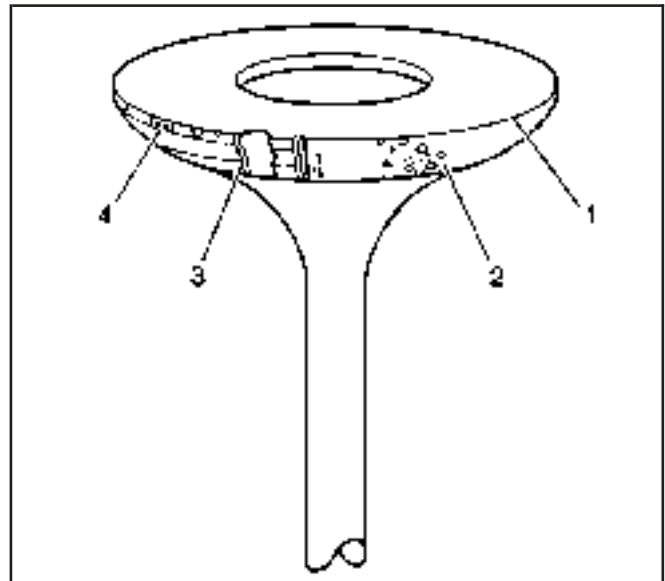
156174

Valve and Seat Grinding

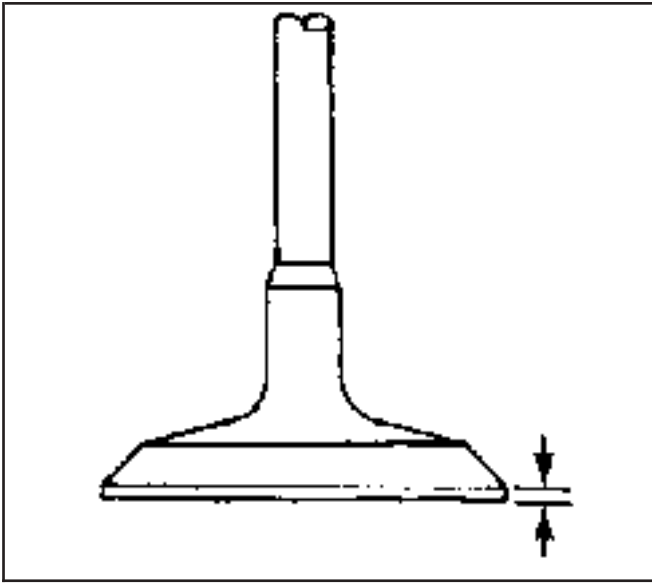
Important:

- Reconditioning the valve seats is very important. The seating of the valves must be perfect for the engine to deliver optimum power and performance. Several different types of equipment are available for grinding valve seats.
- Another important factor is the cooling of the valve head. Good contact between the valve and the seat will ensure that heat will be properly dissipated.
- The recommendations of the manufacturer of the equipment should be followed carefully to obtain the proper results. Regardless of what type of equipment is used, it is essential that valve guide bores be free from carbon or dirt to ensure proper centering of the tool pilot in the guide.

- Valves that are pitted must be refaced to the proper angle. Valve stems that show excessive wear, or valves that are warped excessively must be replaced. When a valve head that is warped excessively is refaced, a knife edge may be ground on part or all of the valve head due to the amount of metal that must be removed. Knife edges lead to breakage, burning or pre-ignition due to heat localizing on this knife edge. If the edge of the valve head is less than 1.25 mm (0.05 in) after grinding, replace the valve.
 - Several different types of equipment are available for refacing valves. The recommendation of the manufacturer of the equipment should be carefully followed to obtain the proper results.
 - DO NOT reface intake valves. Intake valves with excessive wear or damage MUST be replaced.
1. Inspect the valve for the following:
 - Burnt or eroded areas (1)
 - A worn margin (2)
 - A bent stem (3)
 - A worn or scored stem (4)
 - A worn key groove (5)
 - A worn stem tip (6)
 2. Inspect the valve face for the following:
 - Worn or no margin (1 or 4)
 - Pitted surfaces (2)
 - Burnt or eroded areas (3)

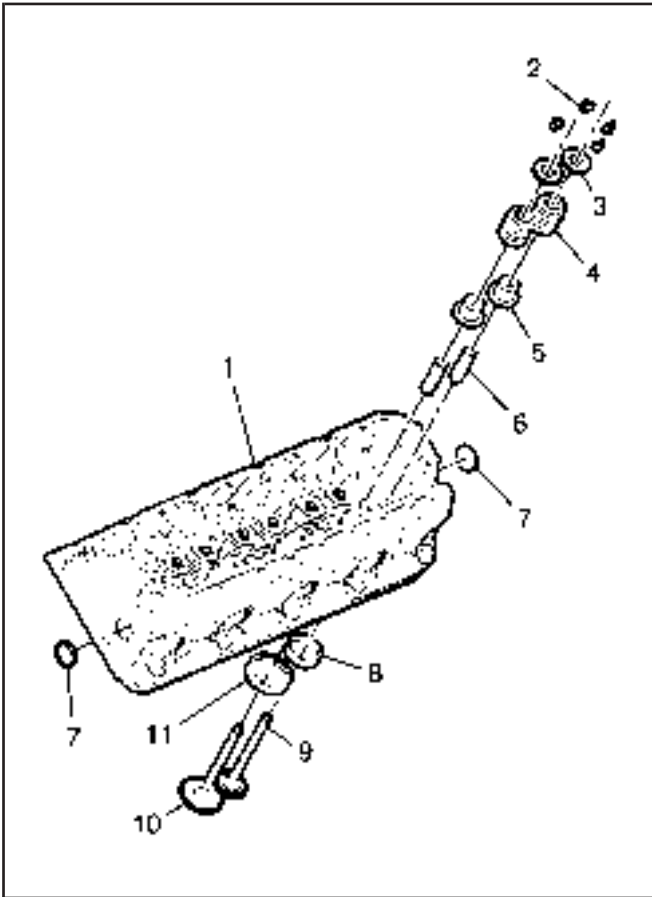


156173



4955

3. Inspect the valve margin.
The exhaust valve may be refaced if the margin is greater than 1.25 mm (0.05 in) thick before grinding.
4. Reface pitted exhaust valves on a suitable valve refacing machine.
5. Replace the valve if the margin is less than 1.25 mm (0.05 in) thick after grinding.
6. If the valve face has been ground, it may be necessary to shim the valve spring to obtain the proper spring installed height. Refer to *Cylinder Head Disassemble*.



822537

7. Inspect for a loose valve seat (8 or 11) in the cylinder head (1). The valve seat has an interference fit to the cylinder head.
8. Clean the valve guide (6) bores with a suitable tool. Remove all carbon or dirt from the bores.
The valve guide must be clean for the seat grinding tool to obtain proper results.
9. Grind the valve seat.
The recommendations of the manufacturer of the equipment should be followed carefully to obtain the proper results. Regardless of what type of equipment is used, it is essential that valve guide bores be free from carbon or dirt to ensure proper centering of the tool pilot in the guide.
10. Inspect the valve seats.
 - The valve seats should be concentric to within 0.05 mm (0.0021 in) total indicator reading.
 - If the valve seat has been ground, it may be necessary to shim the valve spring to attain the proper spring installed height.
Refer to *Cylinder Head Disassemble*.

Cylinder Head Assemble

SIE-ID = 823834 LMD = 26-feb-2002

Tools Required

J 8062 Valve Spring Compressor

1. Clean the cylinder head valve spring seat and/or shim area.

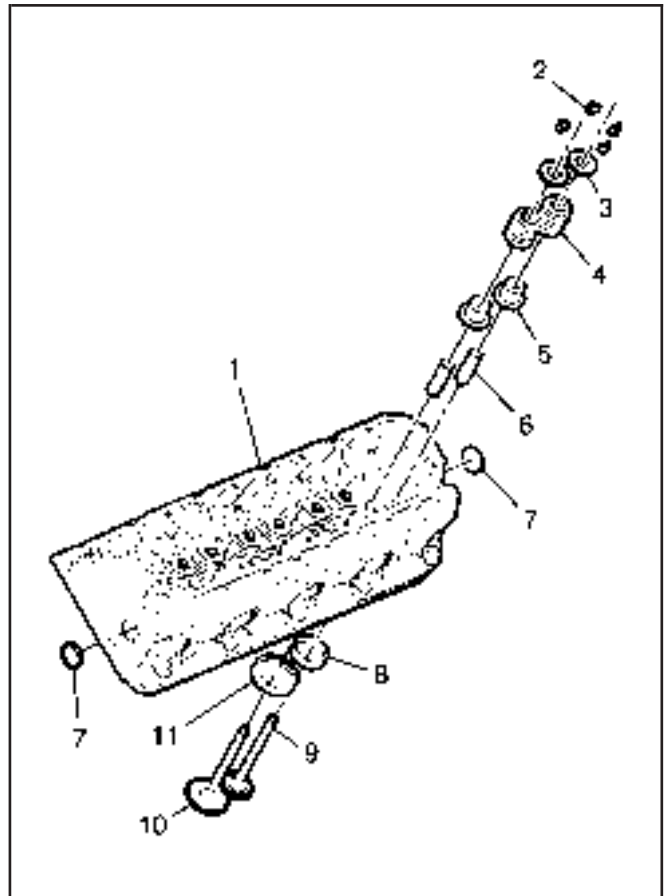
Important: When using the valves and related components again, install the parts to their original location.

2. Install the valves (9 and 10) into the proper guides. Refer to *Separating Parts*.

Important: The valve stem oil seal alignment and position on the valve guide is critical.

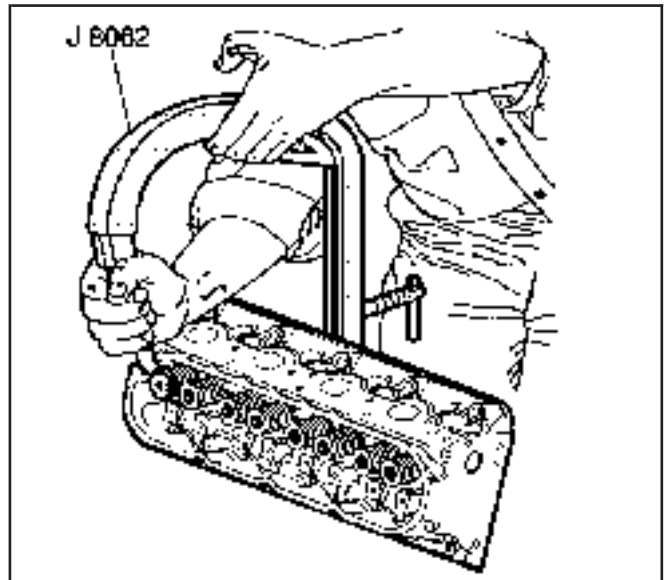
An improperly installed valve stem oil seal may lead to excessive oil consumption, increased vehicle emissions, or component damage.

3. Install the valve stem oil seal and shim assembly (5).
4. Install the valve spring (4).
5. Install the valve spring cap (3).

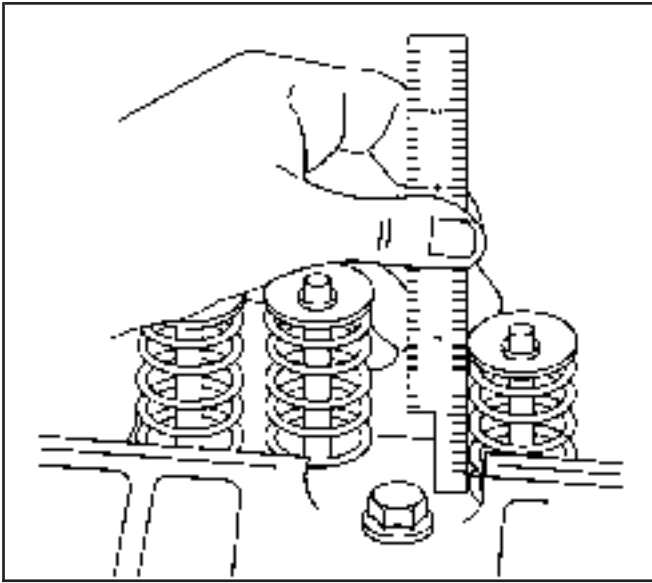


822537

6. Compress the valve spring using the J 8062.
7. Install the valve stem keys.
 - 7.1. Use grease to hold the keys in place and remove the J 8062.
 - 7.2. Make sure the keys seat properly in the groove of the valve stem.
 - 7.3. Tap the end to the valve stem with a plastic faced hammer to seat the keys, if necessary.



260151



64315

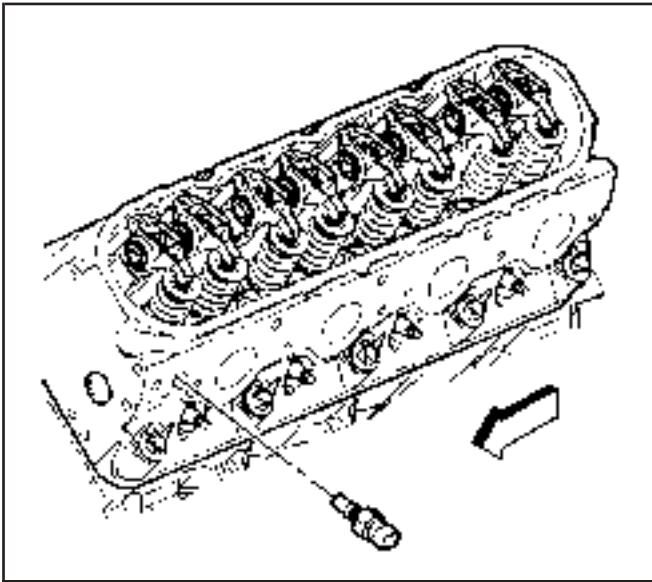
8. Measure the valve spring installed height using a ruler. Measure from the base of the spring to the top of the spring.

If the installed height exceeds 46.25 mm (1.82 in), install a valve seat spring shim of approximately 0.5 mm (0.02 in) thick.

Do not shim the valve spring to obtain less than the specified height.

Do not assemble the components without a spring shim on the cylinder head, aluminum head.

9. Install the remaining valves, springs, and other components.



260086

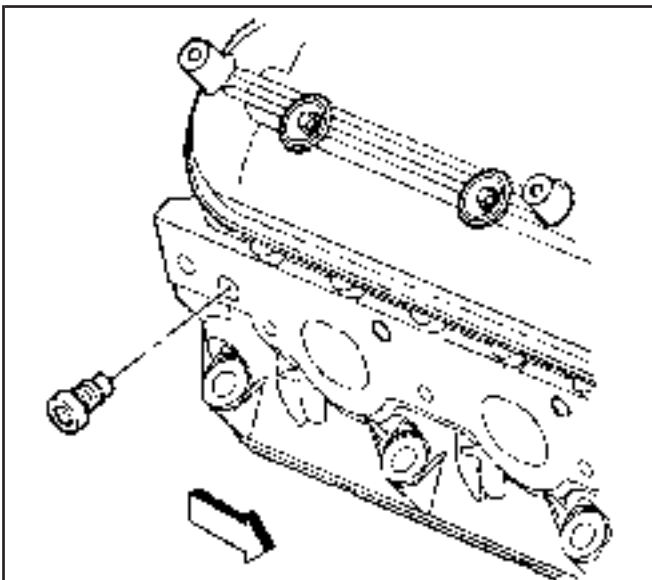
10. Install sealant GM P/N 12346004 (Canadian P/N 10953480) or equivalent to the threads of the coolant sensor.

Notice: Refer to *Fastener Notice* in Cautions and Notices.

11. Install the coolant sensor into the left cylinder head.

Tighten

Tighten the coolant sensor to 20 N·m (15 lb ft).



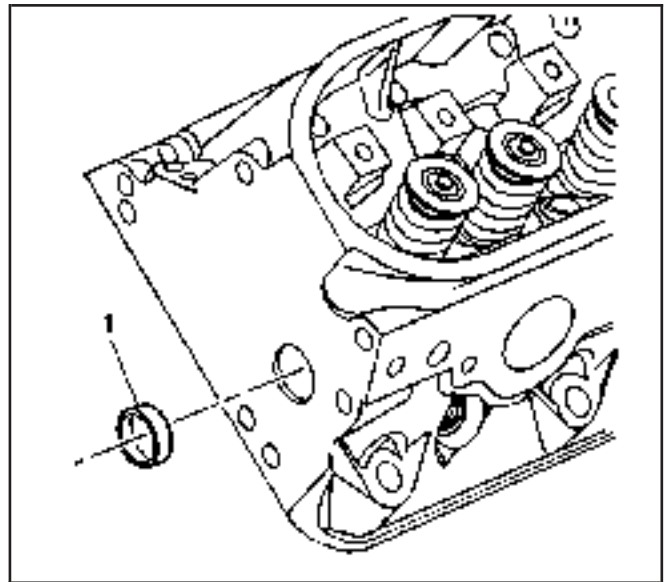
260157

12. Install the coolant plug to the right cylinder head.

Tighten

Tighten the coolant plug to 20 N·m (15 lb ft).

13. Apply threadlock GM P/N 12345382 (Canadian P/N 10953489) or equivalent to the sides of the cylinder head expansion plugs (1), if applicable.
14. Install the expansion plugs into the cylinder head, aluminum head.
A properly installed plug should be slightly below flush with the face of the head.



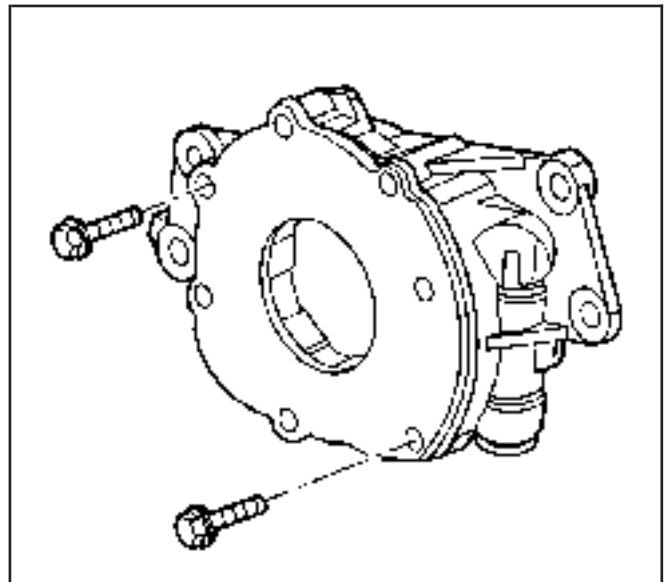
490662

Oil Pump Disassemble

SIE-ID = 768309 LMD = 11-may-2001

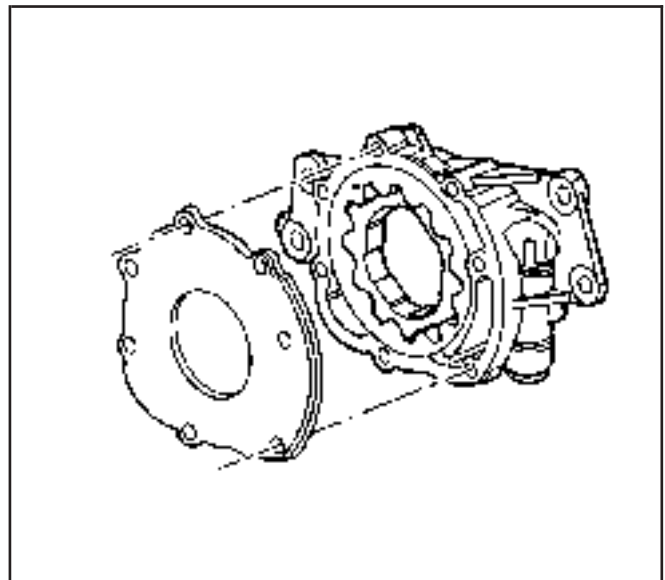
Important: The internal parts of the oil pump assembly are not serviced separately, excluding the spring. If the oil pump components are worn or damaged, replace the oil pump as an assembly.

1. Remove the oil pump cover bolts.

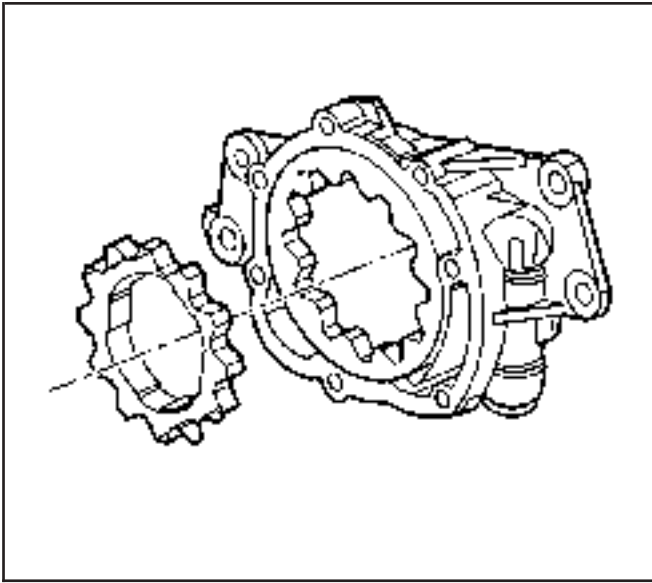


65055

2. Remove the oil pump cover.



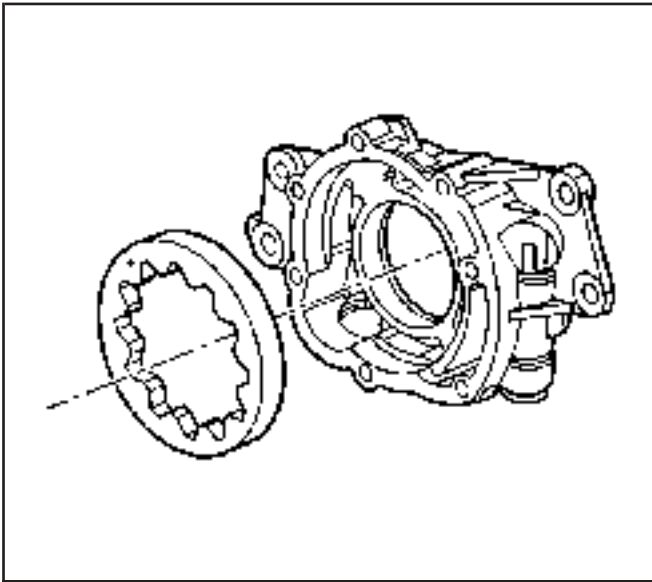
65057



65058

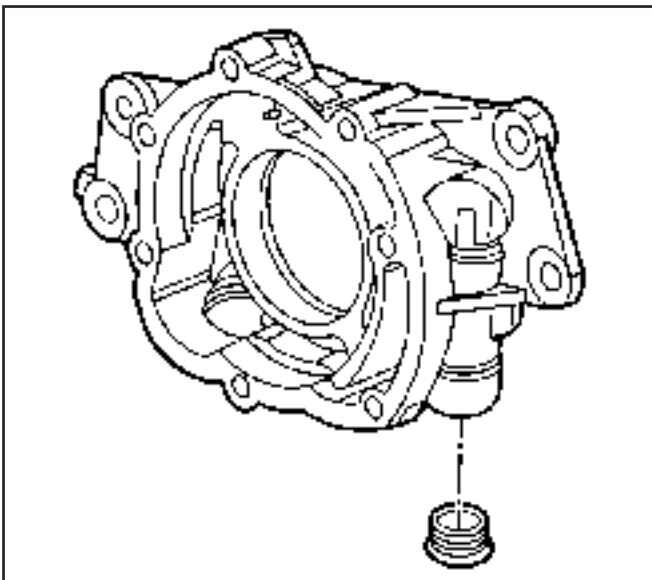
Important: Mark or identify the gears for assembly. Refer to *Separating Parts*.

3. Remove the drive gear.



65060

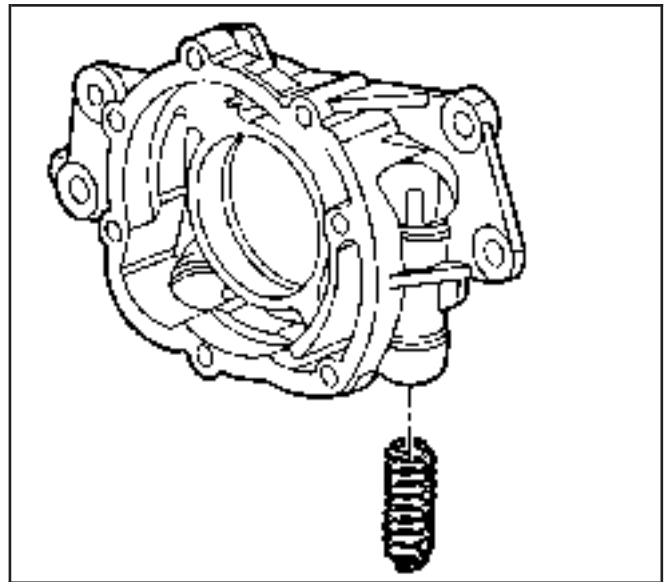
4. Remove the driven gear.



65064

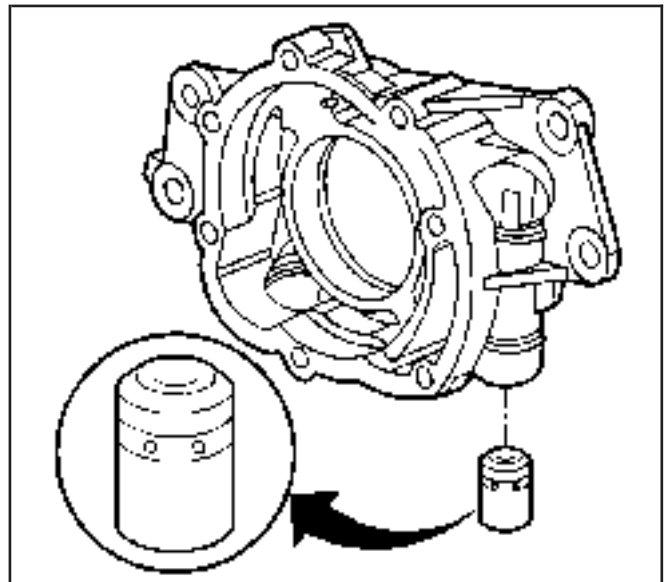
5. Remove the pressure relief valve plug.

6. Remove the pressure relief valve spring.



65068

7. Remove the pressure relief valve.
 8. Inspect the oil pump components. Refer to *Oil Pump Cleaning and Inspection*.



65076

Oil Pump Cleaning and Inspection

SIE-ID = 73755 LMD = 01-oct-2001

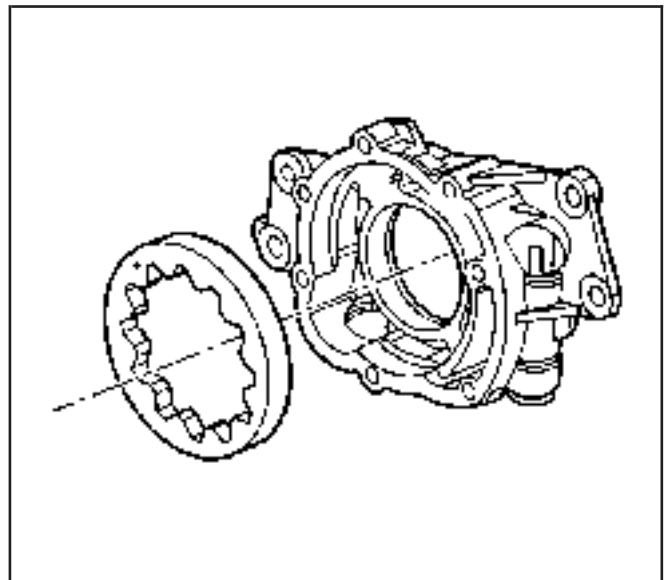
Important: The internal parts of the oil pump assembly are not serviced separately, excluding the spring. If the oil pump components are worn or damaged, replace the oil pump as an assembly.

The oil pump pipe and screen are to be serviced as an assembly. Do not attempt to repair the wire mesh portion of the pump and screen assembly.

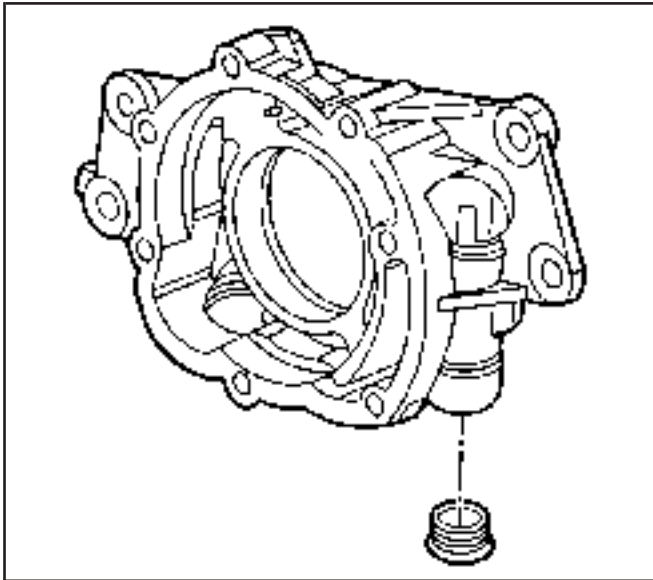
1. Clean the parts in solvent.

Caution: Refer to Safety Glasses Caution in Cautions and Notices.

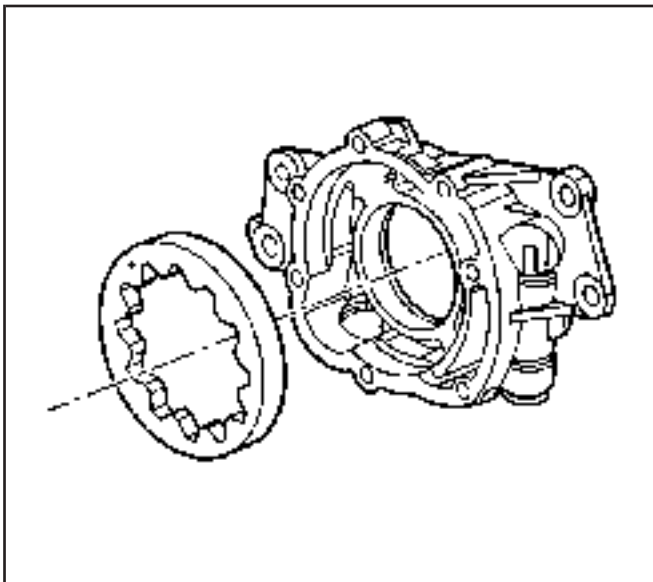
- 2. Dry the parts with compressed air.
- 3. Inspect the oil pump housing and the cover for cracks, excessive wear, scoring, or casting imperfections.



65060



65064

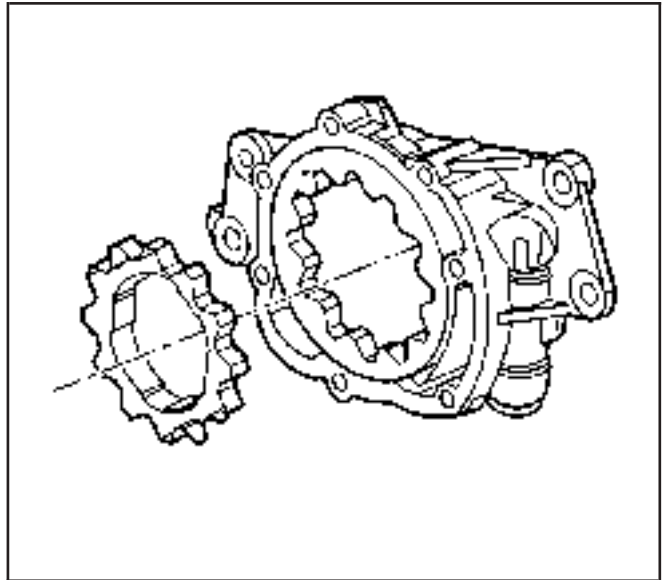


65060

4. Inspect the oil pump housing-to-engine block oil gallery surface for scratches or gouging.
5. Inspect the oil pump housing for damaged bolt hole threads.
6. Inspect the relief valve plug and plug bore for damaged threads.
7. Inspect the oil pump internal oil passages for restrictions.

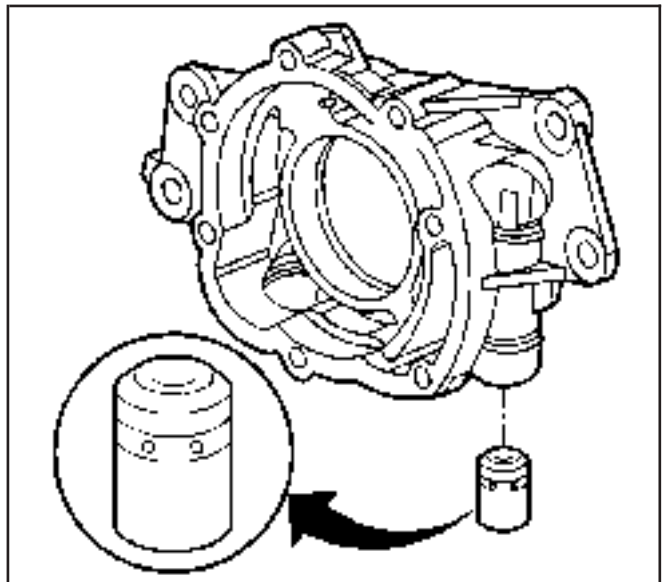
8. Inspect the drive gear and driven gear for chipping, galling or wear.
Minor burrs or imperfections on the gears may be removed with a fine oil stone.

9. Inspect the drive gear splines for excessive wear.



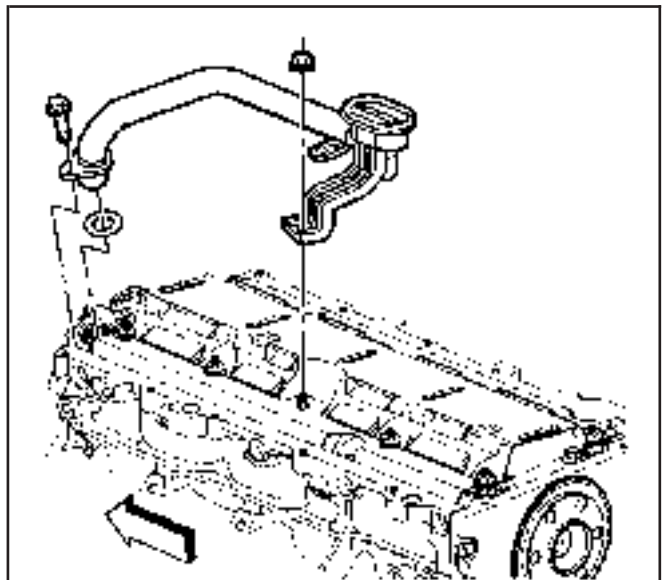
65058

10. Inspect the pressure relief valve and bore for scoring or wear.
The valve must move freely in the bore with no restrictions.

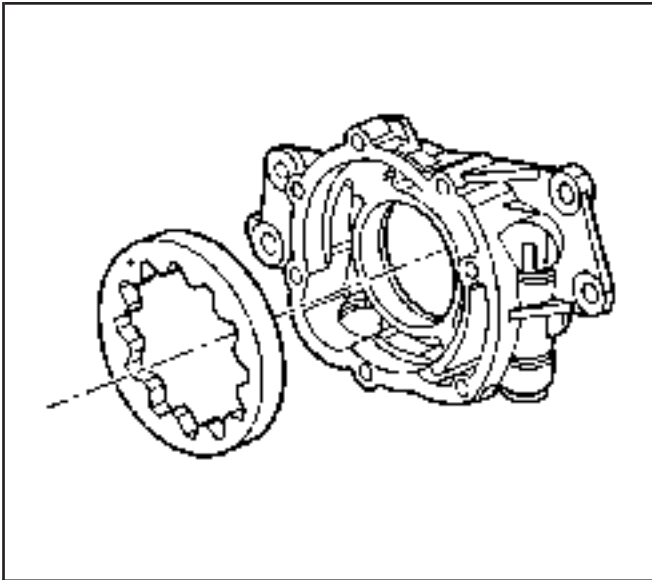


65076

11. Inspect the oil pump screen for debris or restrictions.
12. Inspect the oil pump screen for broken or loose wire mesh.



64268



65060

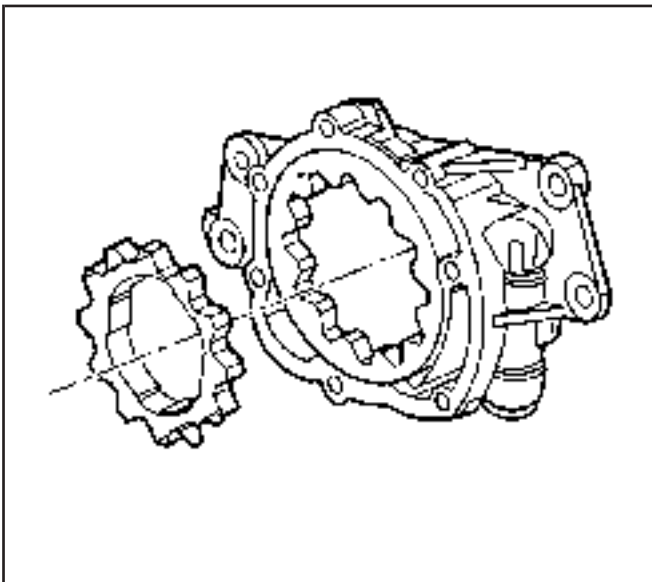
Oil Pump Assemble

SIE-ID = 186385 LMD = 24-jul-1998

SIO-ID = 186100 LMD = 10-jul-1997

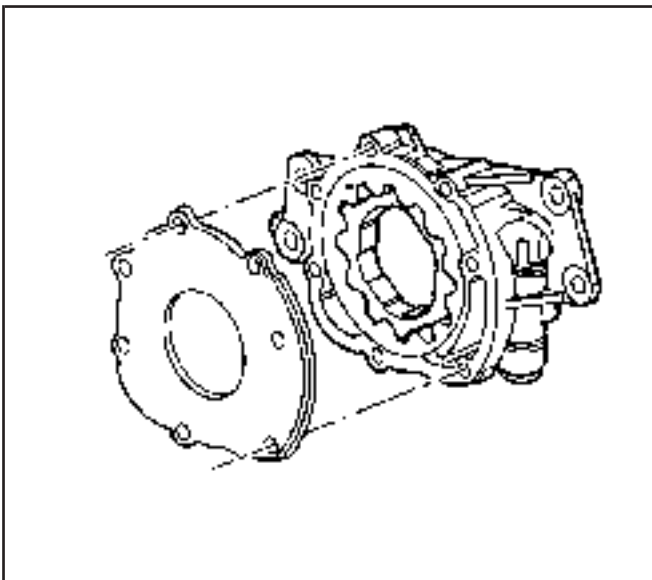
Important: Prior to assembling the oil pump, coat all wear or internal surfaces with clean engine oil.

1. Install the driven gear into the pump housing.
Install the driven gear with the orientation mark facing the pump cover.



65058

2. Install the drive gear into the pump housing.



65057

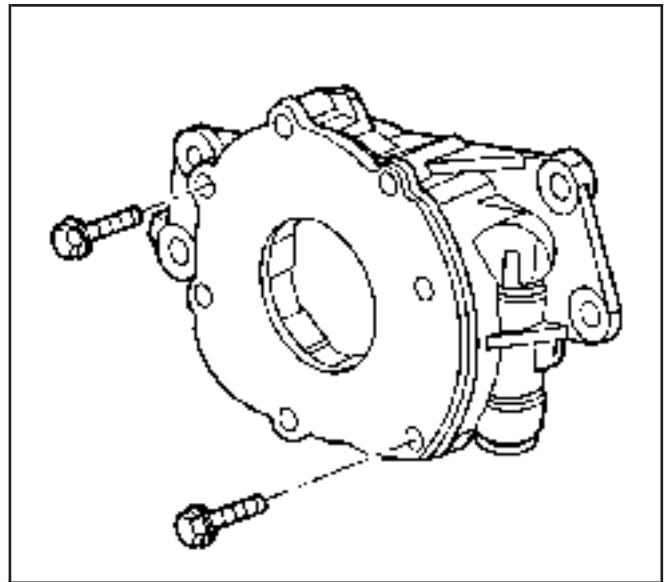
3. Install the oil pump cover.

Notice: Refer to *Fastener Notice* in Cautions and Notices.

4. Install the pump cover bolts.

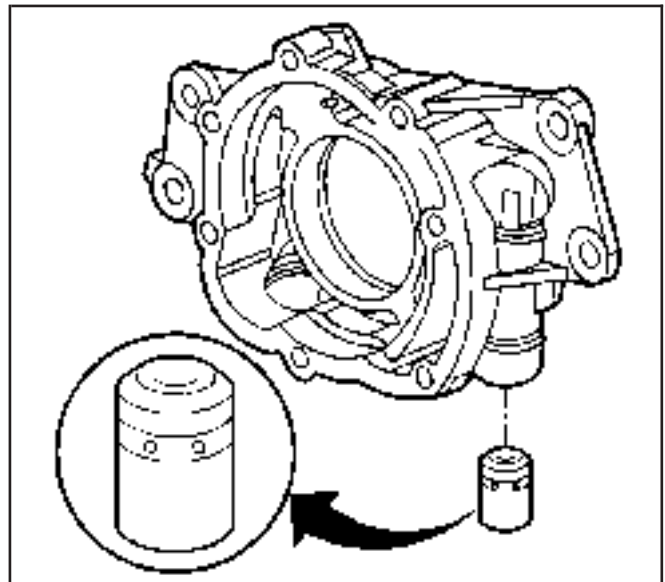
Tighten

Tighten the oil pump cover bolts to 12 N·m (106 lb in).



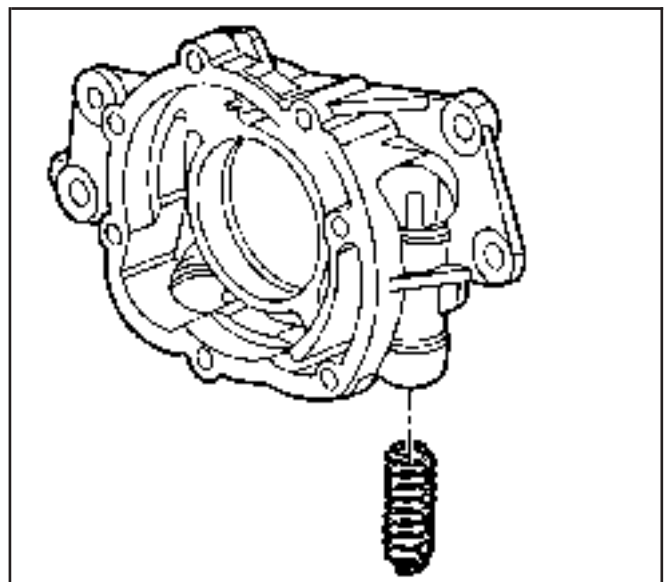
65055

5. Install the regulator valve.

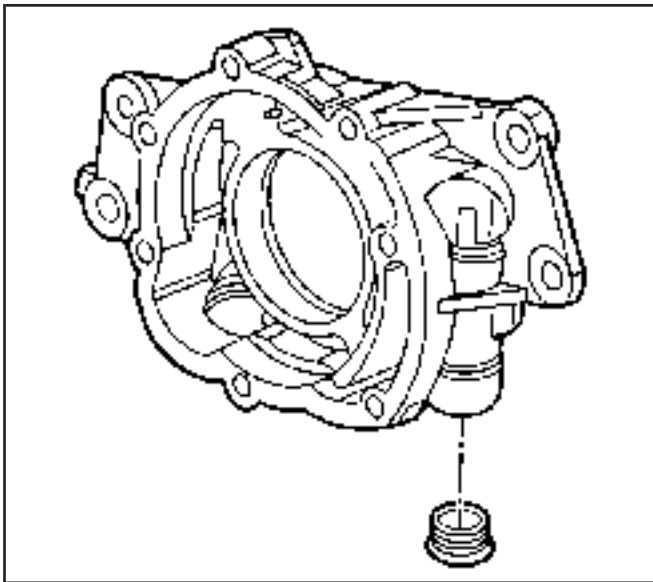


65076

6. Install a NEW regulator valve spring.



65068



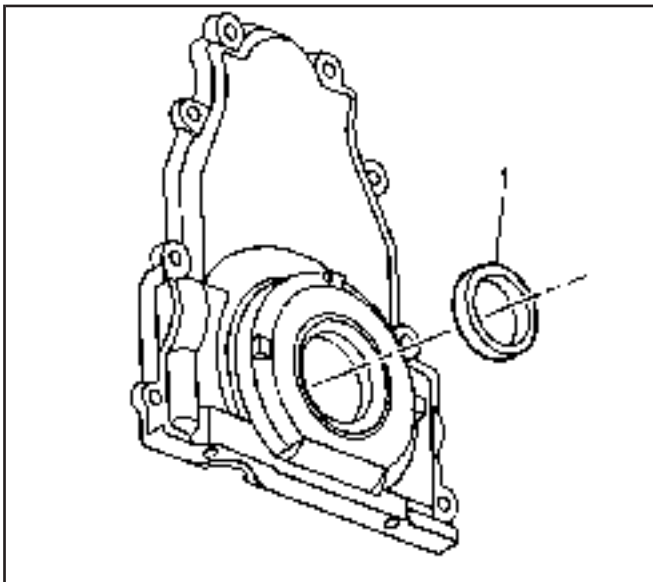
65064

7. Install the pressure relief valve plug.

Tighten

Tighten the pressure relief valve plug to 12 N·m (106 lb in).

8. Inspect the oil pump for smoothness of operation by rotating the drive gear.



490689

Engine Front Cover Cleaning and Inspection

SIE-ID = 797196 LMD = 01-may-2002

Important:

- Do not use the crankshaft oil seal again. Install a NEW crankshaft oil seal during assembly.
- Do not use the front cover-to-engine block gasket again. Install a NEW gasket during assembly.

1. Remove the crankshaft oil seal (1) from the front cover.
2. Clean the cover in solvent. Remove the sealant from the cover oil pan surface. Refer to *Replacing Engine Gaskets*.

Caution: Refer to Safety Glasses Caution in Cautions and Notices.

3. Dry the cover with compressed air.
4. Inspect the gasket sealing surfaces for excessive scratches or gouging.
5. Inspect the cover-to-oil pan threaded bolt holes for damaged threads or debris.
6. Inspect the crankshaft oil seal mounting bore for damage.

Engine Rear Cover Cleaning and Inspection

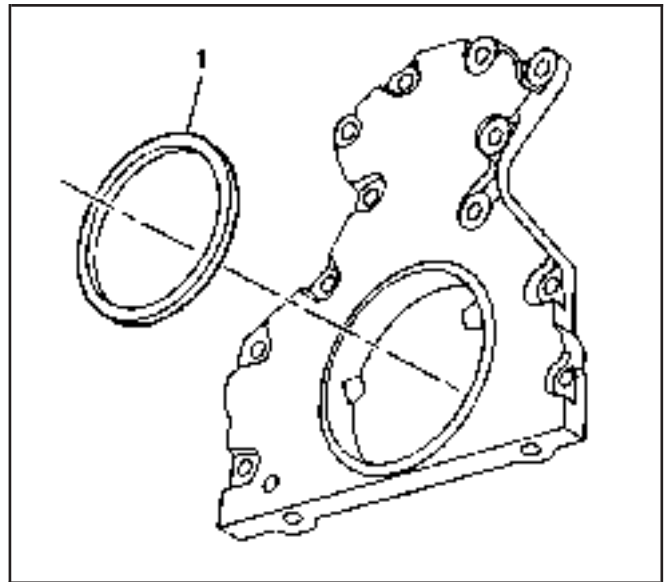
SIE-ID = 797193 LMD = 01-may-2002

Important:

- Do not use the crankshaft oil seal again. Install a NEW crankshaft oil seal during assembly.
 - Do not use the rear cover-to-engine block gasket again. Install a NEW gasket during assembly.
1. Remove the crankshaft oil seal (1) from the rear cover.
 2. Clean the cover in solvent. Remove the sealant from the cover oil pan surface. Refer to *Replacing Engine Gaskets*.

Caution: Refer to Safety Glasses Caution in Cautions and Notices.

3. Dry the cover with compressed air.
4. Inspect the gasket sealing surfaces for excessive scratches or gouging.
5. Inspect the cover-to-oil pan threaded bolt holes for damaged threads or debris.
6. Inspect the crankshaft oil seal mounting bore for damage.



490692

Engine Valley Cover Cleaning and Inspection

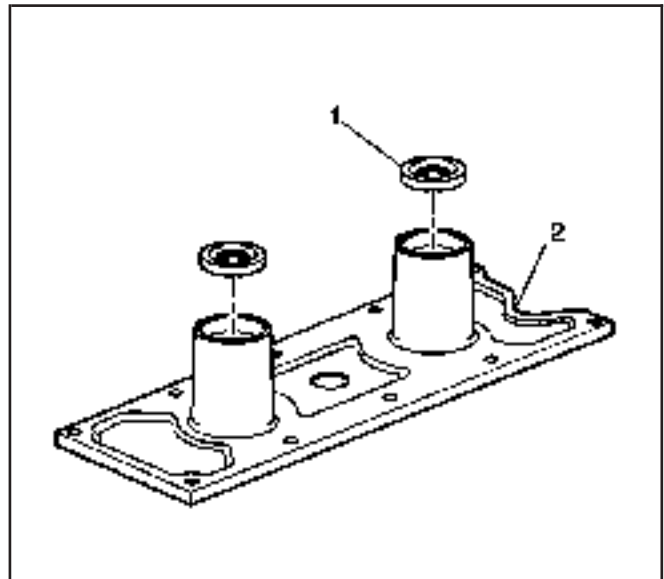
SIE-ID = 768226 LMD = 01-may-2002

Important:

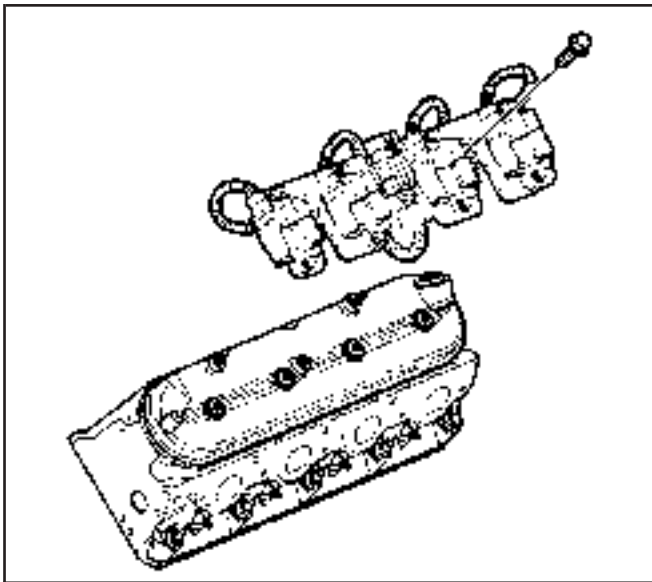
- Do not use the valley cover knock sensor oil seals again. Install NEW oil seals during assembly.
 - Do not use the valley cover gasket again. Install a NEW gasket during assembly.
1. Remove the knock sensor oil seals (1) from the valley cover (2).
 2. Clean the valley cover in solvent.

Caution: Refer to Safety Glasses Caution in Cautions and Notices.

3. Dry the valley cover with compressed air.
4. Inspect the gasket sealing surfaces for excessive scratches or gouging. Refer to *Replacing Engine Gaskets*.
5. Inspect the valley cover oil seal bores for excessive scratches or gouging.



490851



260083

Valve Rocker Arm Cover Cleaning and Inspection

SIE-ID = 281900 LMD = 26-feb-2002

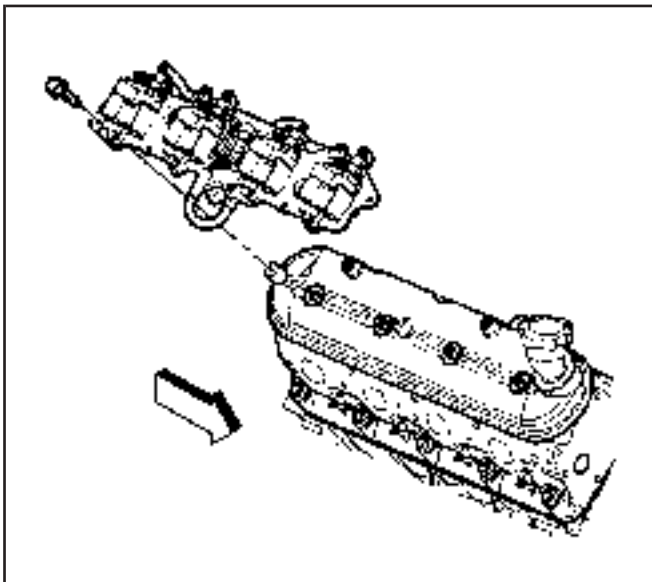
Important: Do not use the valve rocker arm cover gasket again. Install a NEW gasket during assembly.

Remove the ignition coils before cleaning the cover in solvent. Do not submerge the ignition coils in solvent.

Do not remove the oil fill tube or crankcase vent valve grommet from the covers unless service is required.

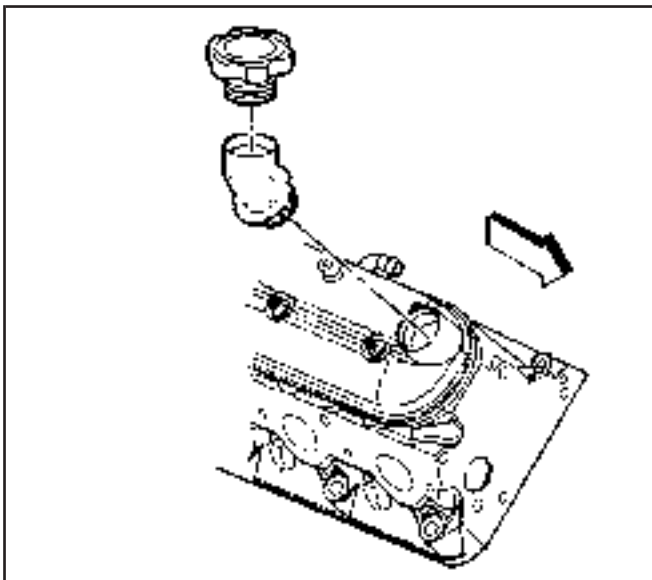
If the oil fill tube or crankcase vent valve grommet have been removed from the rocker arm covers, install a NEW tube or grommet during assembly.

1. Remove the ignition coil and bracket assembly, bolts, and wire harness from the left cover, if required.



260090

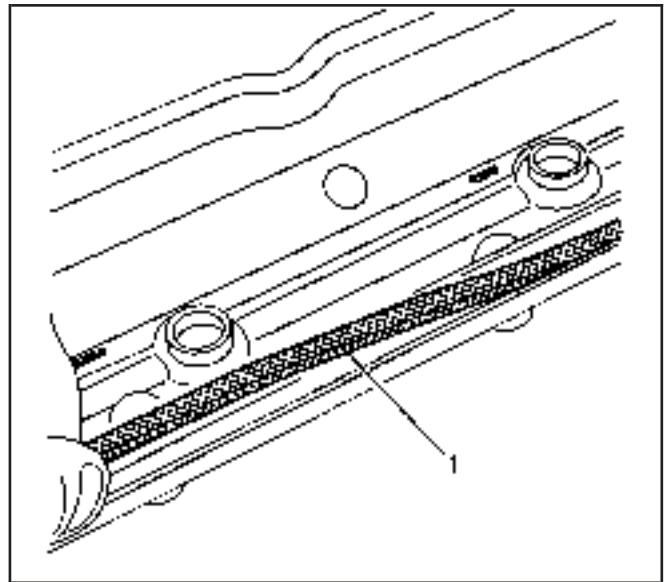
2. Remove the ignition coil and bracket assembly, bolts, and wire harness from the right cover, if required.



260110

3. Inspect the tube for a loose fit or damage.
4. Remove the oil fill cap and tube from the right cover, if required.

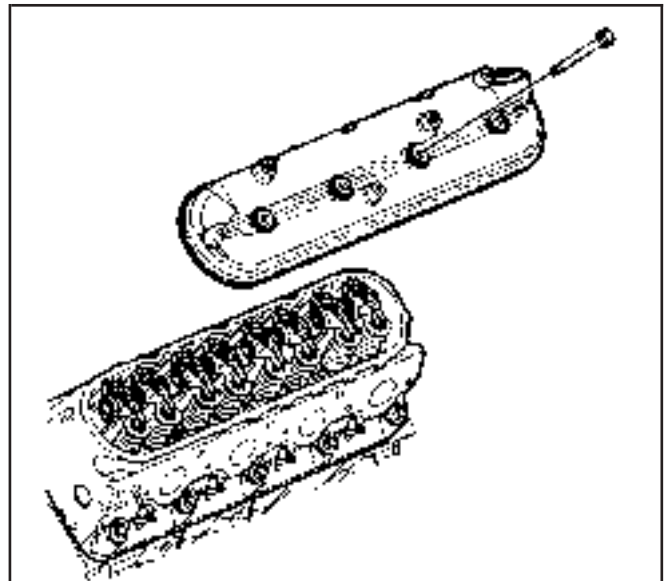
5. Remove the gaskets (1) from the covers.
6. Remove the cover mounting bolts, with grommets.
Cover mounting bolts and grommets that are not damaged may be used again during assembly.
7. Clean the covers in solvent.



490696

Caution: Refer to Safety Glasses Caution in Cautions and Notices.

8. Dry the covers with compressed air.
9. Inspect the ventilation system passages for restrictions.
10. Inspect the gasket grooves for damage.
11. Inspect the coil bracket threaded bolt holes for damage or debris.



260085

Oil Pan Cleaning and Inspection

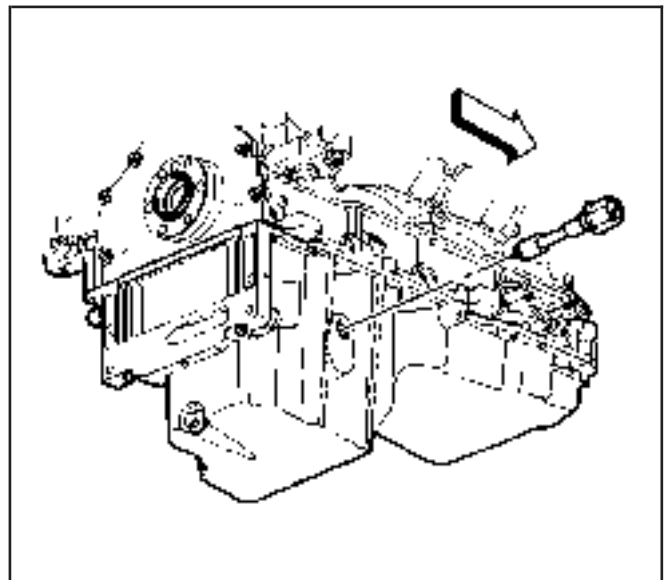
SIE-ID = 281902 LMD = 26-feb-2002

Important: Do not use the oil pan cover gasket again. Install a NEW cover gasket during assembly.

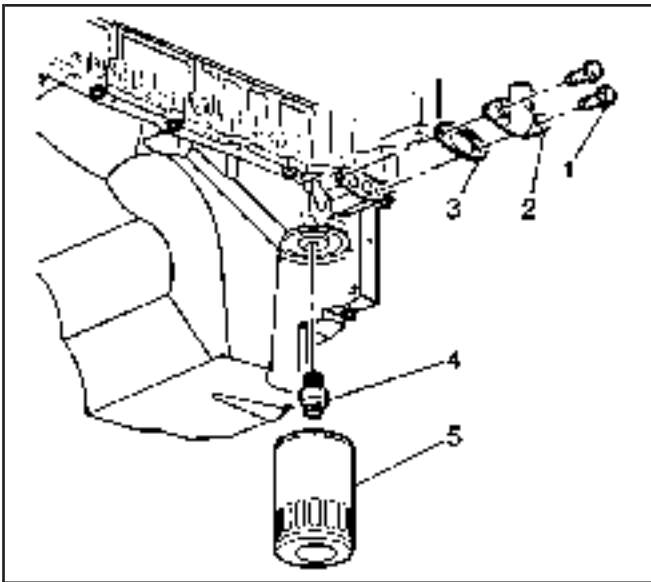
Do not use the oil pan to engine block gasket again. Install a NEW gasket during assembly.

When installing a NEW oil pan gasket, it is not necessary to install the rivets that retain the NEW gasket to the pan.

1. Remove the oil level sensor from the pan.

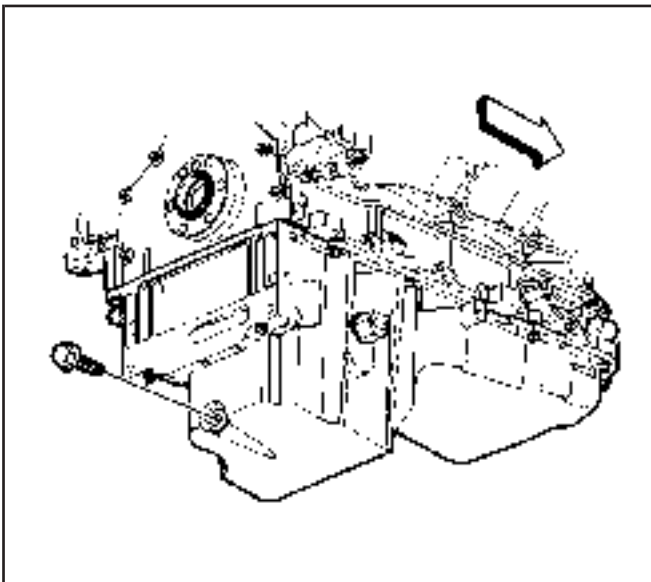


260123



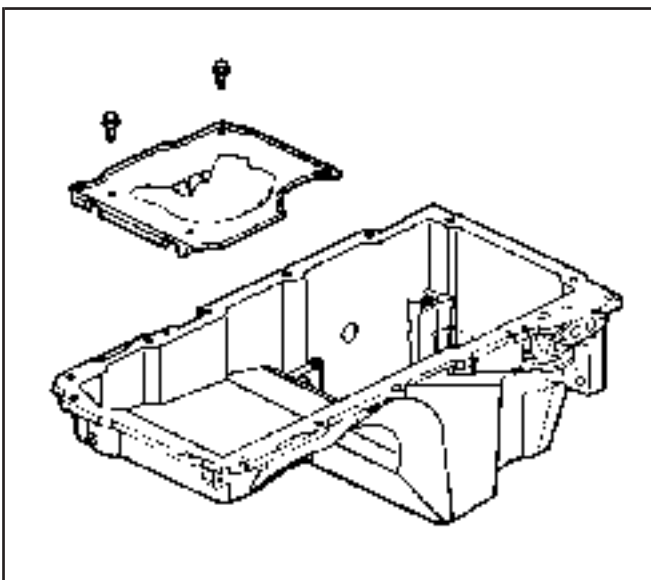
260125

2. Remove the oil pan cover (2), gasket (3), and bolts (1), if required.



260111

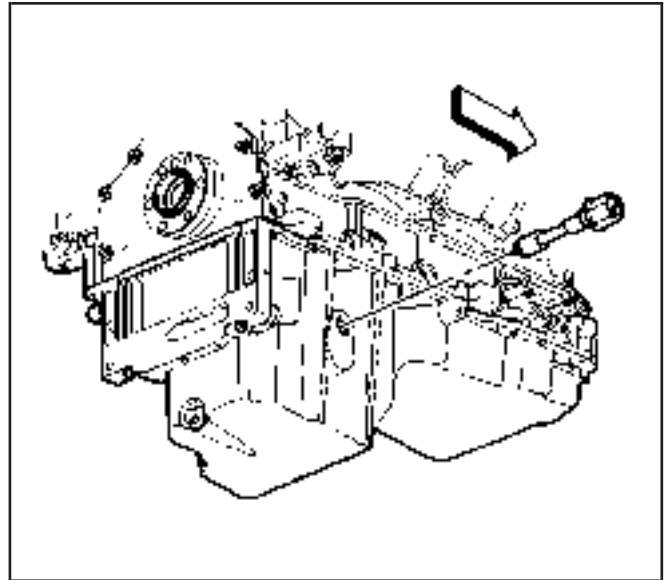
3. Remove the oil pan drain plug and O-ring seal.



260180

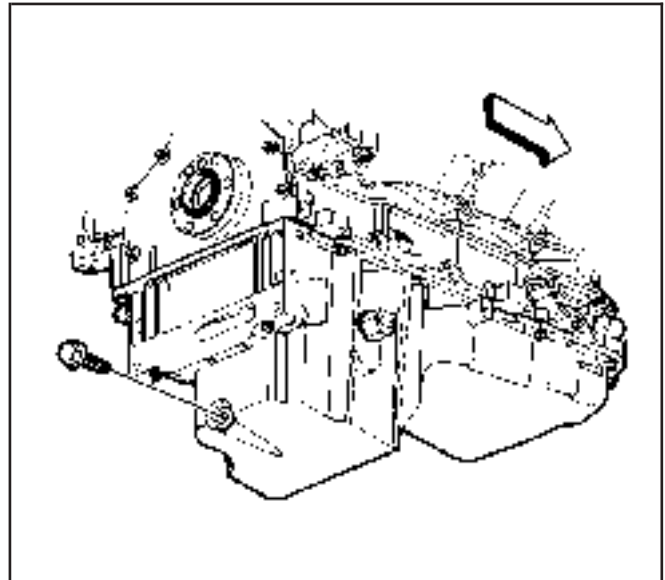
4. Remove the oil pan baffle and bolts.
 5. Clean the oil pan in solvent. Be sure to thoroughly clean all of the oil passages and recesses of the pan.
 6. Clean the oil pan gasket surfaces. Refer to *Replacing Engine Gaskets*.
- Caution:** Refer to *Safety Glasses Caution in Cautions and Notices*.
7. Dry the oil pan with compressed air.
 8. Inspect the gasket sealing surfaces for excessive scratches or gouging. Refer to *Replacing Engine Gaskets*.

- 9. Inspect the oil level sensor seal surface and threads for damage.



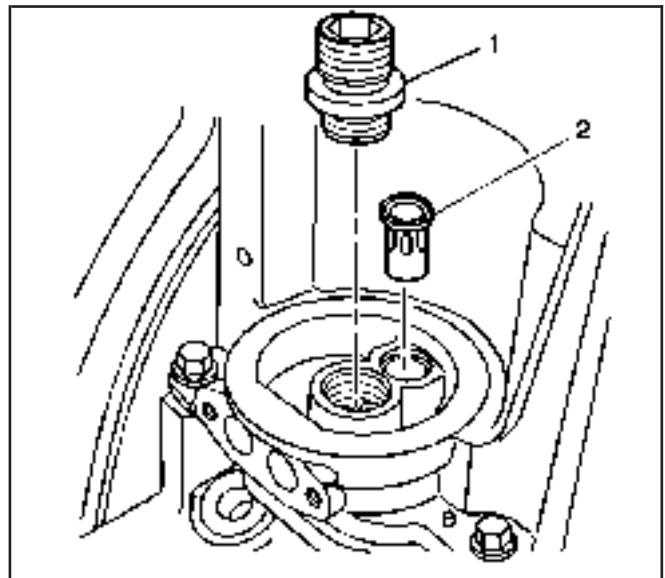
260123

- 10. Inspect the oil pan drain plug and threaded drain hole for damaged threads.
The drain plug O-ring seal may be used again if not cut or damaged.

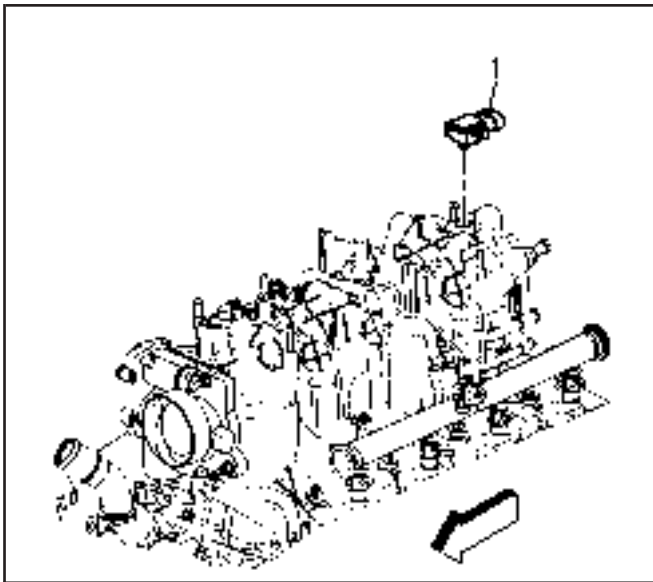


260111

- 11. Inspect the oil filter sealing surface for scratches or gouging.
- 12. Inspect the oil filter fitting (1) for a loose fit or damaged threads.
- 13. Inspect the oil passages for restrictions.
- 14. Inspect the oil filter bypass valve (2) for proper operation.
Lightly depress the bypass valve. The valve spring should reseal the valve to the proper position.



490699



863068

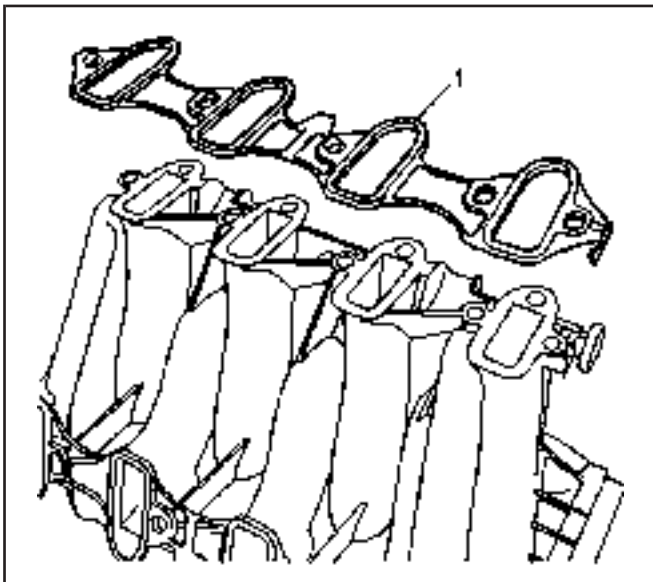
Intake Manifold Cleaning and Inspection

SIE-ID = 863433 LMD = 25-mar-2002

Cleaning Procedure

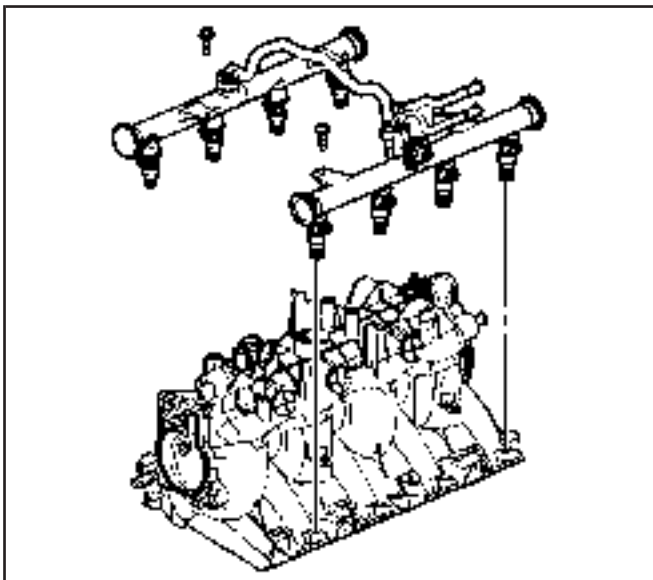
Important: Do not use the intake manifold-to-cylinder head sealing gaskets again.

1. Remove the manifold absolute pressure (MAP) sensor (1) from the rear of the intake. The MAP sensor is to be reinstalled upon completion of the cleaning and inspection procedures.
2. Inspect the sealing grommet on the MAP sensor. The grommet should not be torn or damaged.



492770

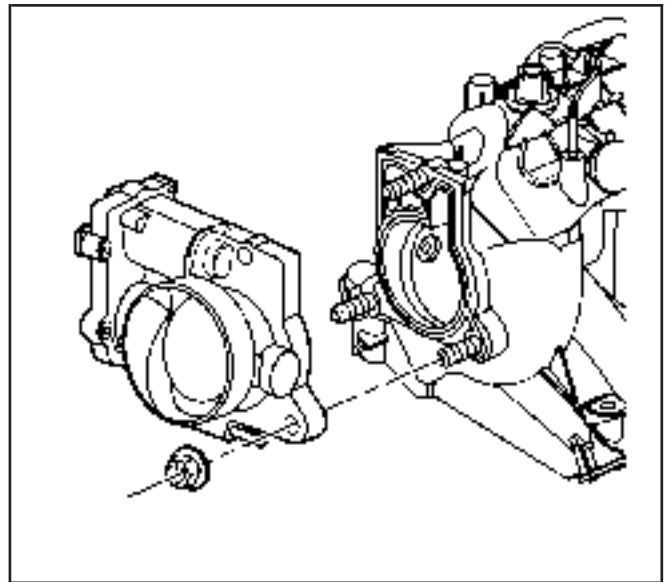
3. Remove and discard the intake manifold-to-cylinder head gaskets (1).



260176

4. Remove the fuel rail with injectors. Refer to *Fuel Rail and Injectors Removal*.

5. Remove the throttle body and gasket. Refer to *Throttle Body Removal*.

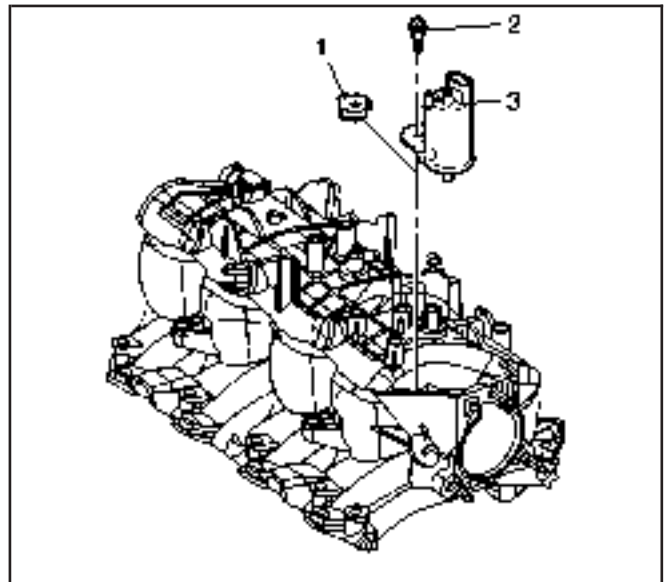


825837

6. Remove the evaporative emissions (EVAP) purge solenoid (3), bolt (2), and isolator (1).
7. Clean the intake manifold in solvent.
 - Clean the intake manifold gasket surfaces.
 - Clean the intake manifold internal passages.

Caution: Refer to *Safety Glasses Caution in Cautions and Notices*.

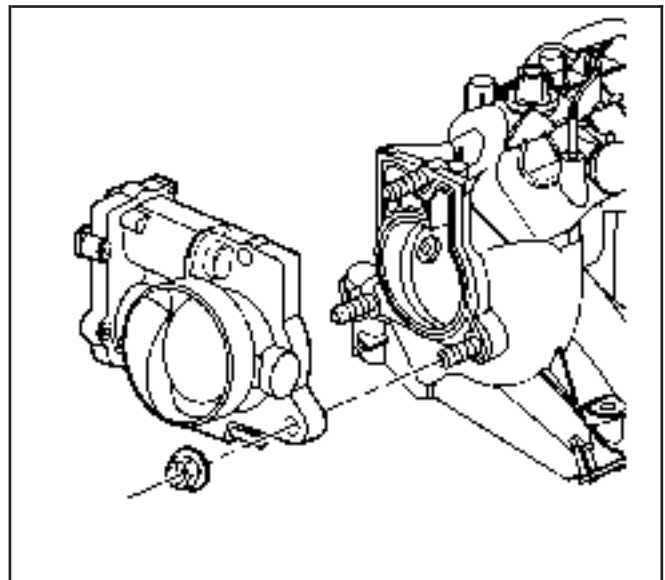
8. Dry the intake manifold with compressed air.



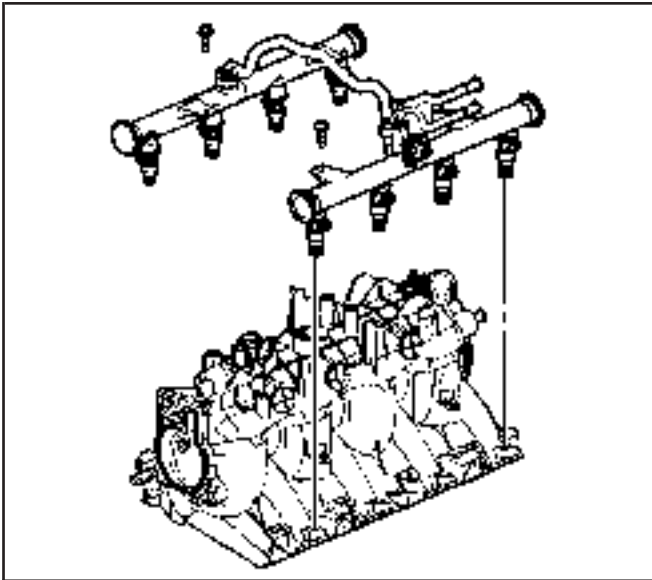
869529

Inspection Procedure

1. Inspect the throttle body studs and threaded inserts for looseness or damaged threads.
2. Inspect the wire harness stud and threaded insert for looseness or damaged threads.

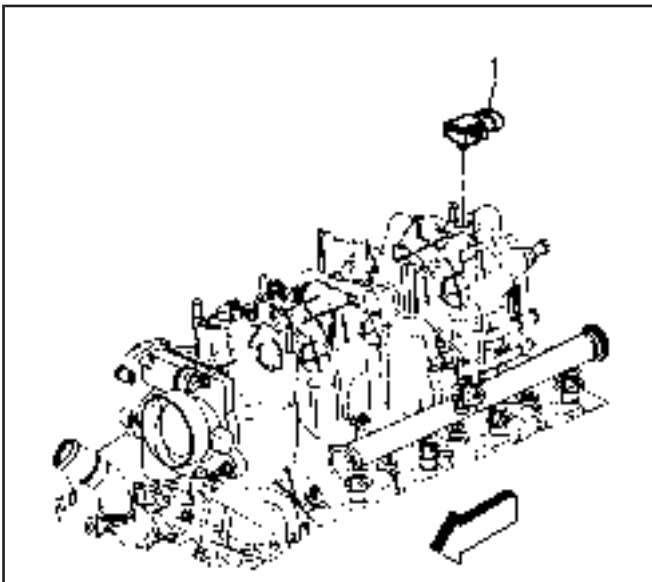


825837



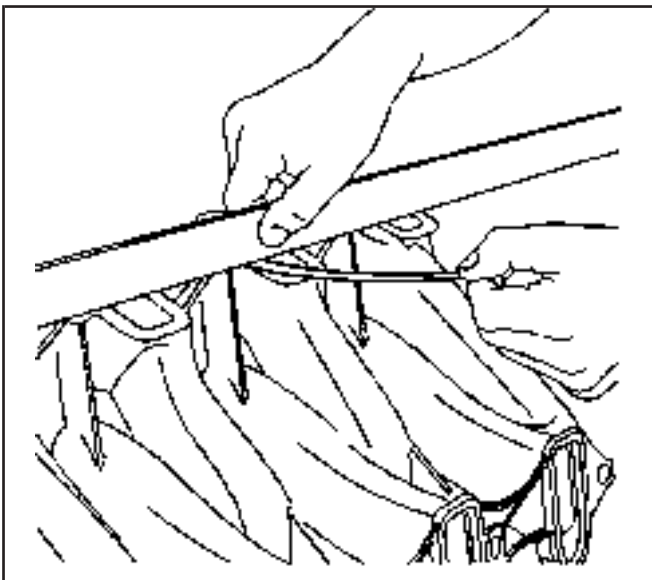
260176

3. Inspect the fuel rail bolt inserts for looseness or damaged threads.
4. Inspect the intake manifold vacuum passages for debris or restrictions.



863068

5. Inspect for damaged or broken vacuum fittings, damaged MAP sensor (1) mounting bore, or broken MAP sensor retaining tabs.
6. Inspect the composite intake manifold assembly for cracks or other damage.
Inspect the areas between the intake runners.
7. Inspect all the gasket sealing surfaces for damage.



492779

8. Inspect the fuel injector bores for excessive scoring or damage.
9. Inspect the intake manifold cylinder head deck for warpage.
 - 9.1. Locate a straight edge across the intake manifold cylinder head deck surface.
Position the straight edge across a minimum of two runner port openings.
 - 9.2. Insert a feeler gage between the intake manifold and the straight edge.
A intake manifold with warpage in excess of 3 mm (0.118 in) over a 200 mm (7.87 in) area is warped and should be replaced.

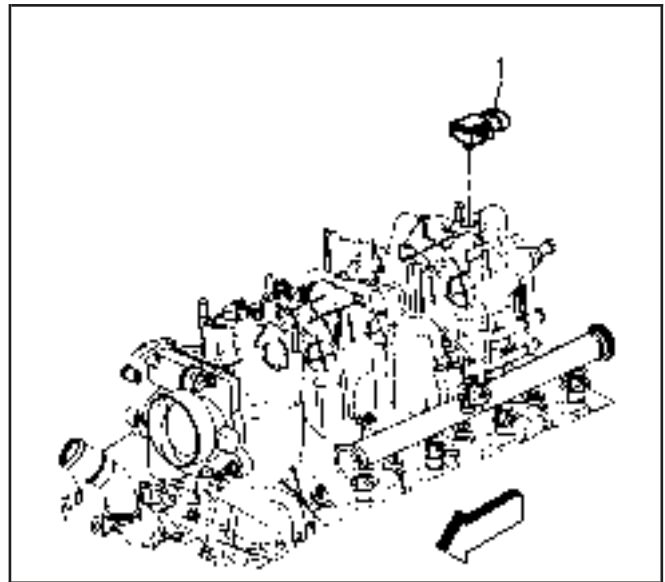
10. Install the MAP sensor (1).

Notice: Refer to *Fastener Notice* in Cautions and Notices.

11. Install the EVAP solenoid, bolt, and isolator.

Tighten

Tighten the EVAP solenoid bolt to 10 N·m (89 lb in).



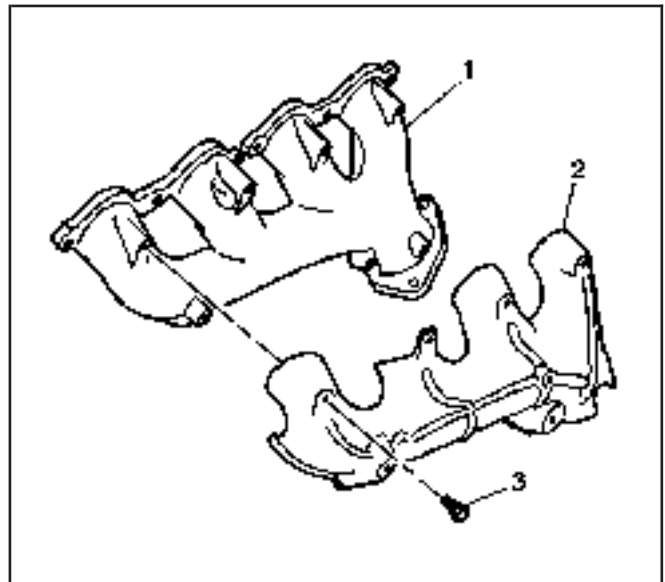
863068

Exhaust Manifold Cleaning and Inspection

SIE-ID = 823836 LMD = 04-apr-2002

Important: Do not use the exhaust manifold-to-cylinder head gaskets again. Upon installation of the exhaust manifold, install a NEW gasket. An improperly installed gasket or leaking exhaust system may effect On-Board Diagnostics (OBD) II system performance.

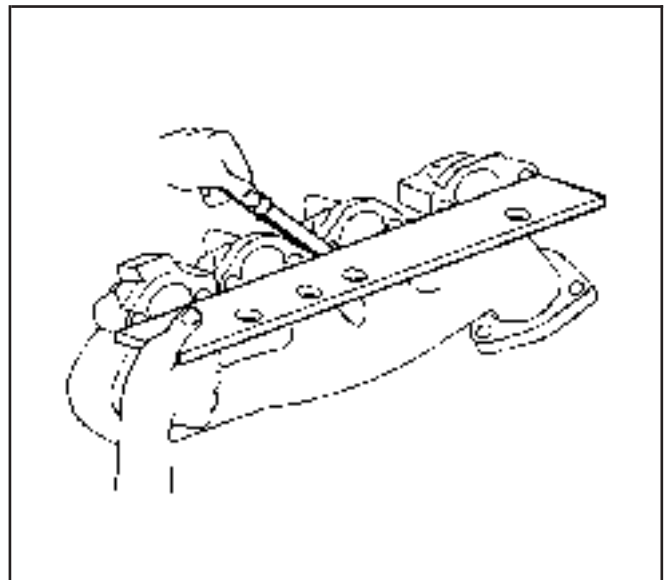
1. Clean the exhaust manifold (1) and heat shield (2) in solvent.
2. Dry the exhaust manifold with compressed air.
3. Inspect the exhaust manifold-to-cylinder head gasket surface for excessive scratches or gouging.
4. Inspect for a loose or damaged heat shield (2).
5. Inspect the take down studs for damaged threads.



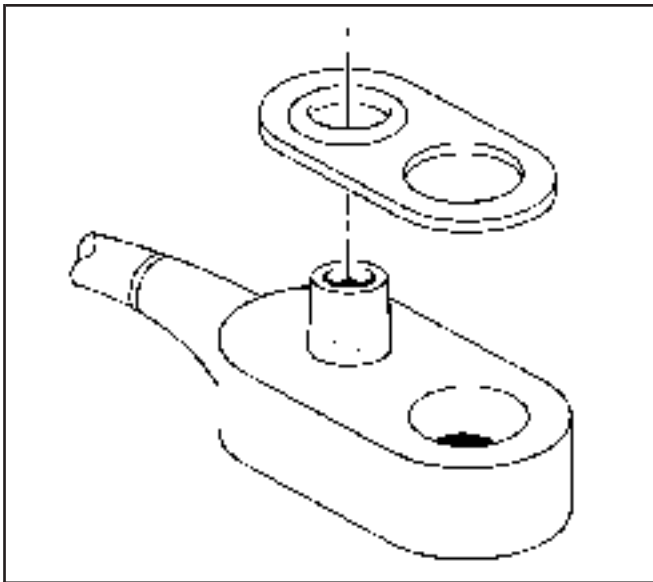
492766

6. Use a straight edge and a feeler gage and measure the exhaust manifold cylinder head deck for warpage.

An exhaust manifold deck with warpage in excess of 0.25 mm (0.01 in) within the two front or two rear runners or 0.5 mm (0.02 in) overall, may cause an exhaust leak and may effect OBD II system performance. Exhaust manifolds not within specifications must be replaced.



66607



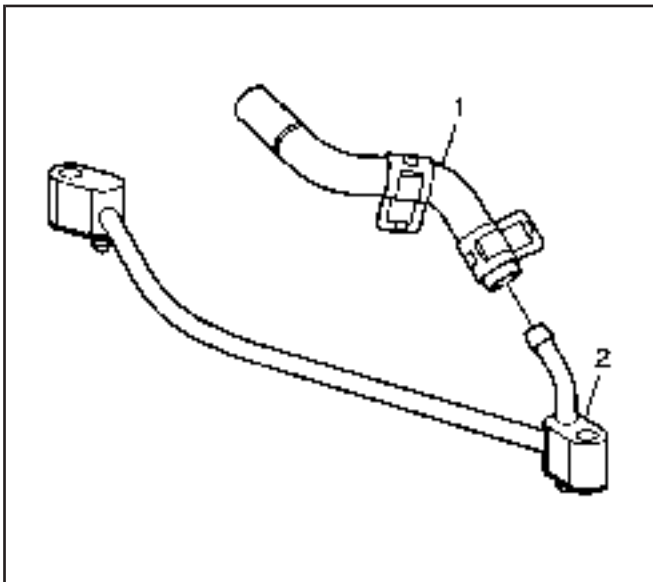
64262

Coolant Air Bleed Pipe Cleaning and Inspection

SIE-ID = 790858 LMD = 26-feb-2002

Important: Do not use the engine coolant air bleed pipe and cover gaskets again. Upon installation of the pipe and covers, install NEW gaskets.

1. Remove the sealing gaskets from the pipe.
2. Remove the sealing gaskets from the covers.

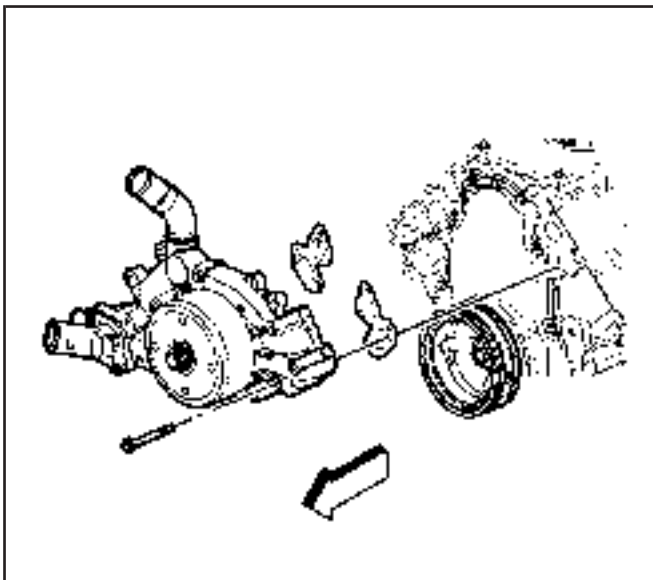


790766

3. Clean the pipe (2), hose (1), and covers in solvent.

Caution: Refer to *Safety Glasses Caution in Cautions and Notices*.

4. Dry the pipe and covers with compressed air.
 5. Inspect the pipe and covers for damage or restrictions.
 6. Inspect the gasket and hose sealing surfaces for damage.
 7. Inspect the hose (1) for restrictions, cracking or wear.
- The hose may be used again if it is not damaged.



260121

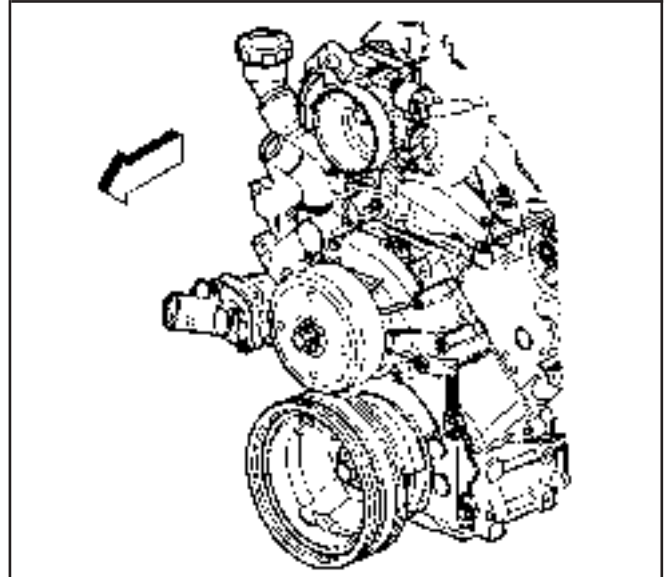
Water Pump Cleaning and Inspection

SIE-ID = 281912 LMD = 18-mar-2002

1. Remove the old gasket from the water pump sealing surfaces. Refer to *Replacing Engine Gaskets*.
2. Clean all excess dirt and debris from the water pump housing.
3. Inspect the water pump for the following:
 - Gasket and hose sealing surfaces for excessive scratches or gouging
 - Restrictions within the internal coolant passages
 - Excessive side-to-side play in the pulley shaft
 - Leakage at the water outlet housing or rear cover gasket
 - Leakage at the water pump vent hole

A stain around the vent hole is acceptable. If leakage, dripping, occurs with the engine running and the cooling system pressurized, replace the water pump.

4. Inspect the water pump pulley for wear or damage in the belt tracking area.



260124

Thread Repair

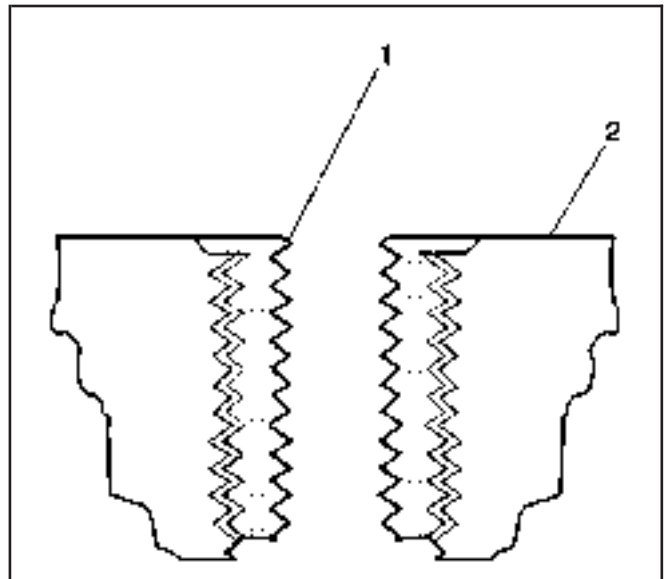
SIE-ID = 323084 LMD = 01-mar-2002

Tools Required

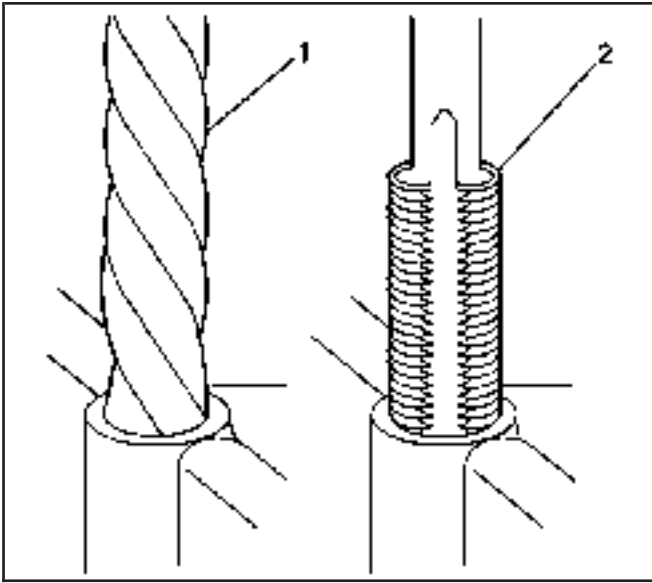
- J 42385-100 Head/Main Bolt Thread Repair Kit
- J 42385-200 General Threads Kit
- J 42385-300 Fixtures/Hardware Kit

General Thread Repair

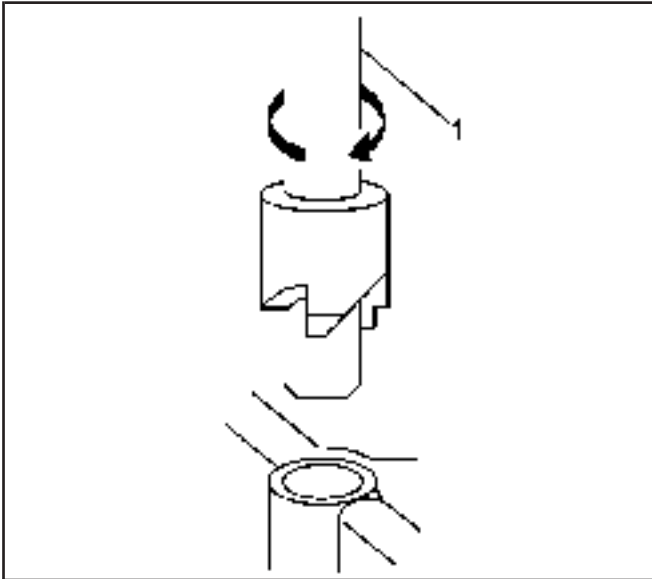
The thread repair process involves a solid, thin walled, self-locking, carbon steel, bushing type insert (1). During the bushing installation process, the driver tool expands the bottom external threads of the insert into the base material (2). This action mechanically locks the insert in place. Also, when installed to the proper depth, the flange of the insert will be seated against the counterbore of the repaired hole.



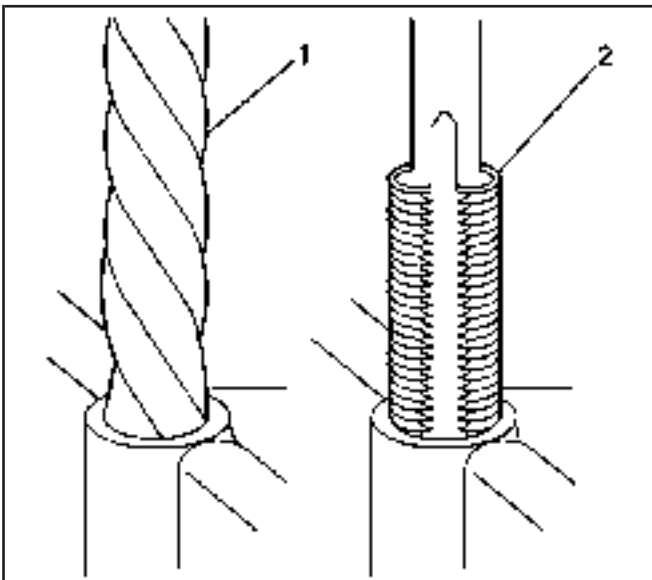
320675



320670



320672



320670

Caution: Refer to Safety Glasses Caution in Cautions and Notices.

Important: The use of a cutting type fluid GM P/N 1052864 (Canadian P/N 992881), WD 40[®], or equivalent is recommended when performing the drilling, counterboring, and tapping procedures.

Driver oil MUST be used on the installer driver tool.

The tool kits are designed for use with either a suitable tap wrench or drill motor.

1. Drill out the threads of the damaged hole (1).
 - M6 inserts require a minimum drill depth of 15 mm (0.59 in).
 - M8 inserts require a minimum drill depth of 20 mm (0.79 in).
 - M10 inserts require a minimum drill depth of 23.5 mm (0.93 in).

2. Using compressed air, clean out any chips.

3. Counterbore the hole to the full depth permitted by the tool (1).

4. Using compressed air, clean out any chips.

5. Using a tap wrench (2), tap the threads of the drilled hole.

- M6 inserts require a minimum tap depth of 15 mm (0.59 in).

- M8 inserts require a minimum tap depth of 20 mm (0.79 in).

- M10 inserts require a minimum tap depth of 23.5 mm (0.93 in).

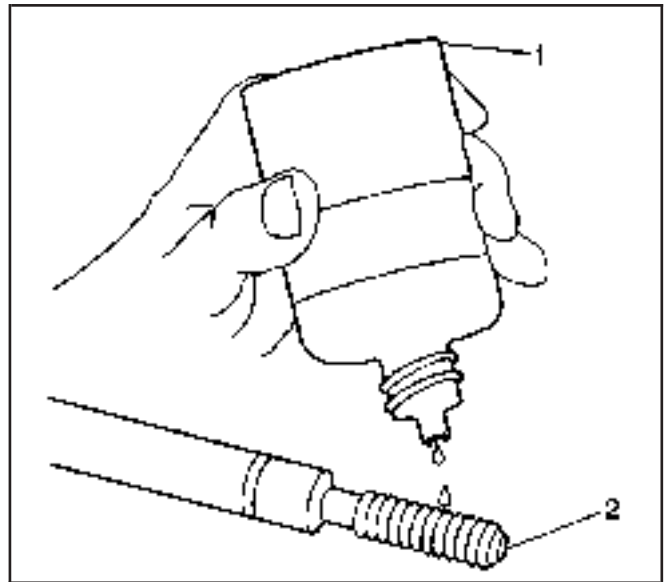
6. Using compressed air, clean out any chips.

7. Spray cleaner GM P/N 12346139 (Canadian P/N 10953463), GM P/N 12377981 (Canadian P/N 10953463) or equivalent into the hole.

8. Using compressed air, clean any cutting oil and chips out of the hole.

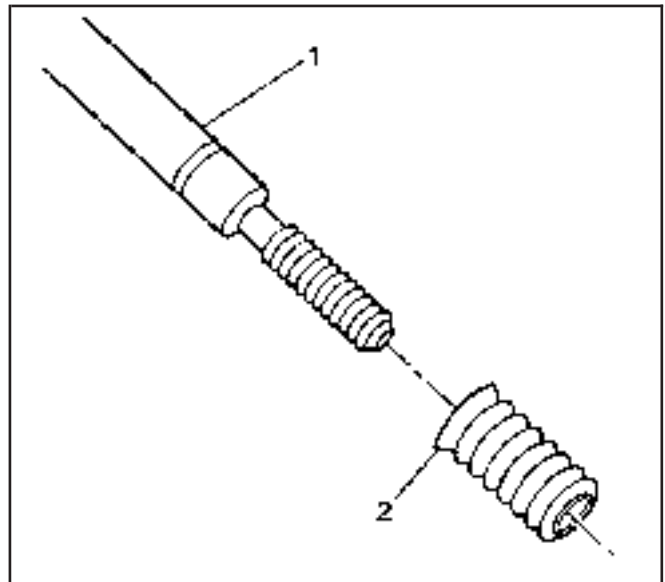
Important: Do not allow oil or other foreign material to contact the outside diameter (OD) of the insert.

9. Lubricate the threads of the installer tool (2) with the driver oil (1).



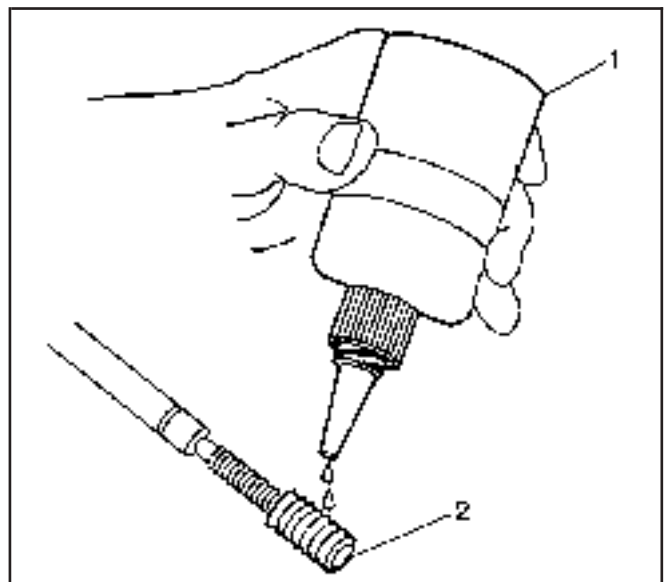
313562

10. Install the insert (2) onto the driver tool (1).

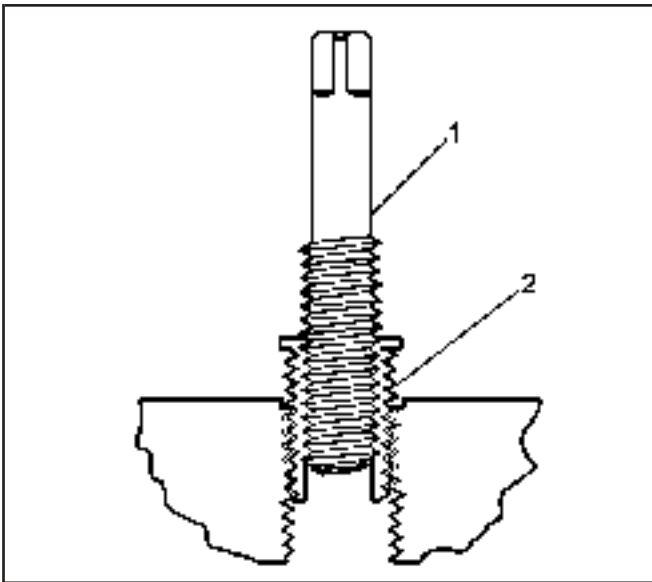


313567

11. Apply threadlock LOCTITE™ 277, J 42385-109 (1), or equivalent to the insert OD threads (2).



313572

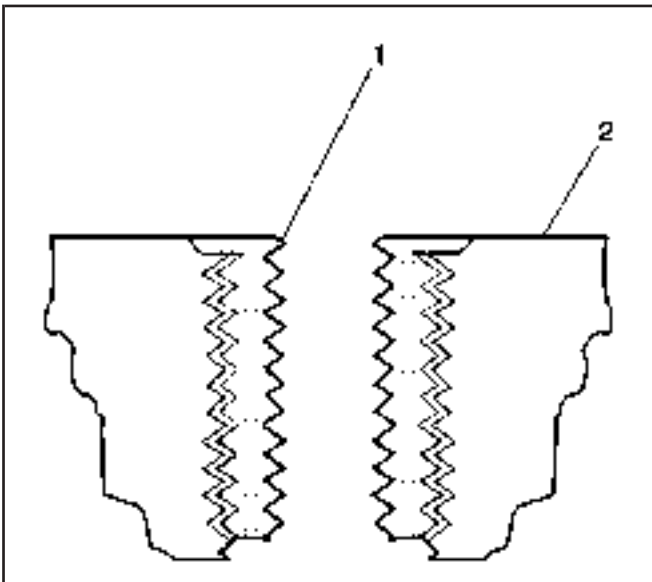


320673

12. Install the insert (2) into the hole.

Install the insert until the flange of the insert contacts the counterbored surface. Continue to rotate the installer tool (1) through the insert.

The installer tool will tighten up before screwing completely through the insert. This is acceptable. You are forming the bottom threads of the insert and mechanically locking the insert to the base material threads.



320675

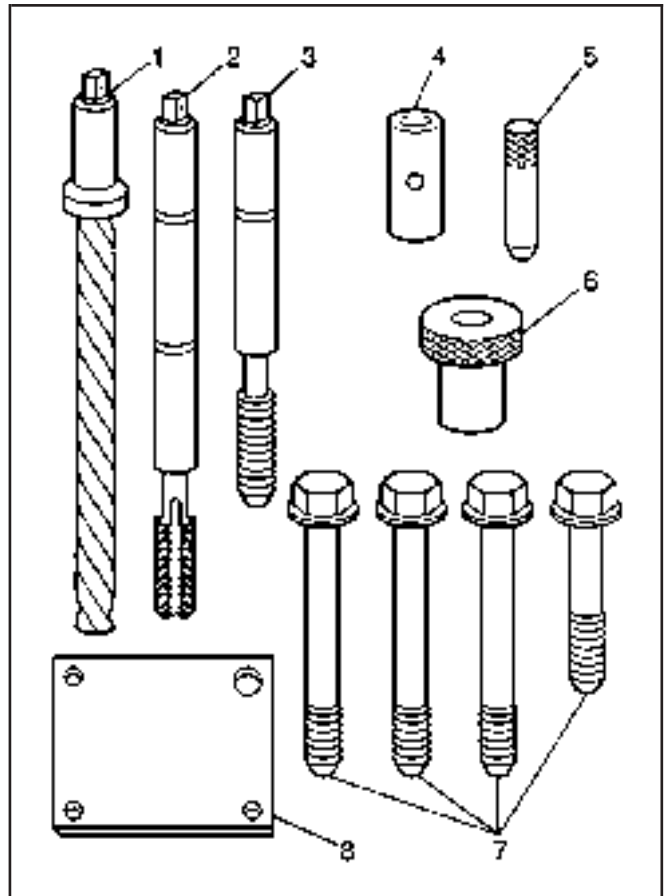
13. Inspect the insert for proper installation into the hole.

A properly installed insert (1) will be either flush or slightly below flush with the surface of the base material (2).

Cylinder Head Bolt Hole Thread Repair

1. The cylinder head bolt hole thread repair kit consists of the following items:

- The drill (1)
- The tap (2)
- The installer (3)
- The sleeve (4)
- The alignment pin (5)
- The bushing (6)
- The bolts (7)
- The fixture plate (8)



313560

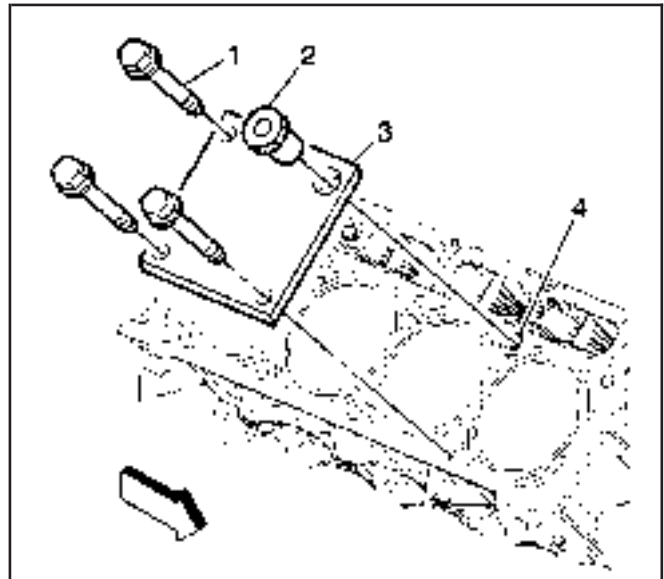
Caution: Refer to Safety Glasses Caution in Cautions and Notices.

Important: The use of a cutting type fluid GM P/N 1052864 (Canadian P/N 992881), WD 40®, or equivalent is recommended when performing the drilling and tapping procedures.

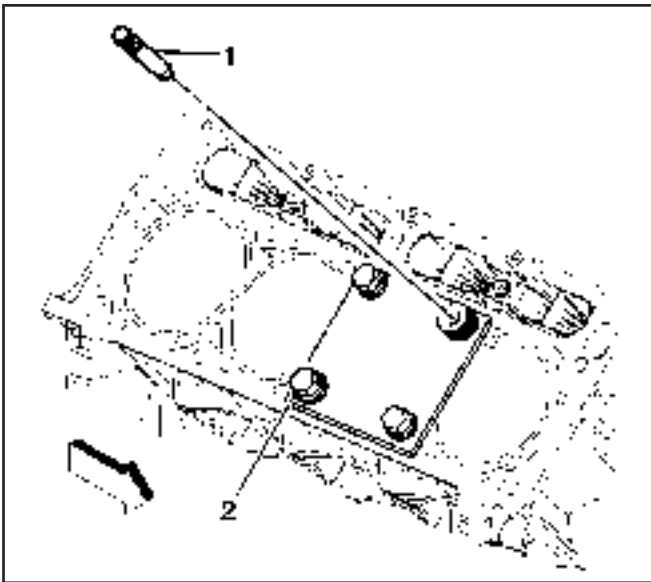
Driver oil **MUST** be used on the installer driver tool.

The tool kits are designed for use with either a suitable tap wrench or drill motor.

2. Install the fixture plate (3), bolts (1), and bushing (2) onto the engine block deck. Position the fixture plate and bushing over the hole that is to be repaired (4).

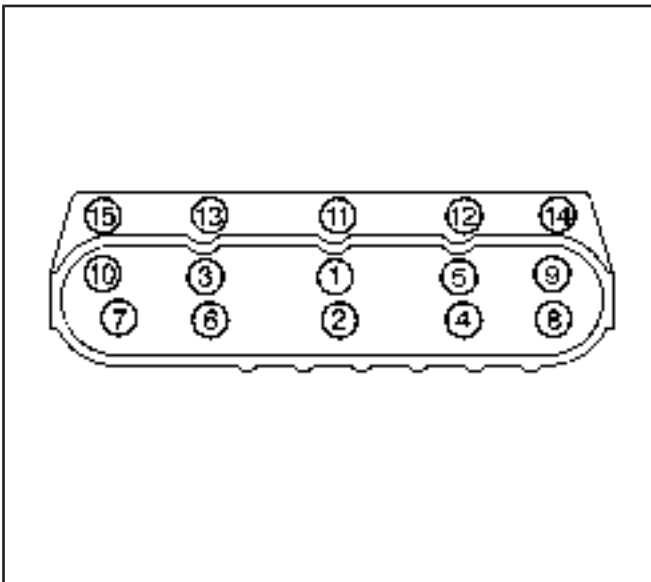


313574



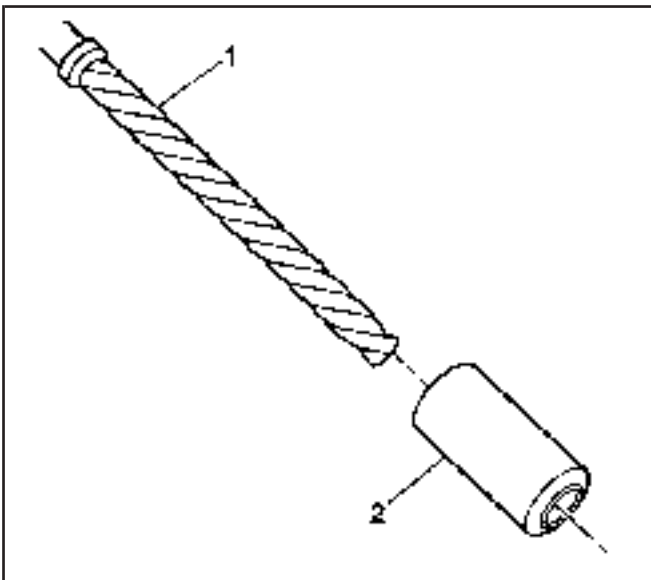
313577

3. Position the alignment pin (1) through the bushing and into the hole.
4. With the alignment pin in the desired hole, tighten the fixture retaining bolts (2).
5. Remove the alignment pin from the hole.



260150

6. Cylinder head bolt holes 1–8 are the deep holes and will be drilled without the drill sleeve. Cylinder head bolt holes 9 and 10 are the shallower holes, drilling **MUST** be done with the drill sleeve in place.

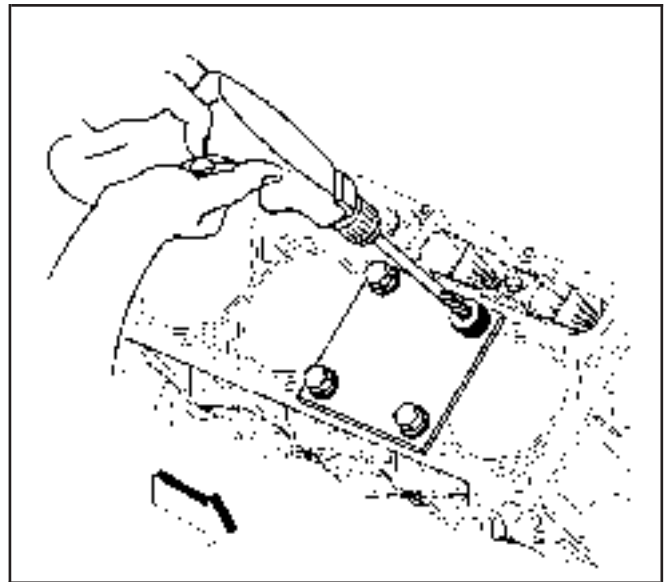


313570

7. Install the sleeve (2) onto the drill (1), if required.

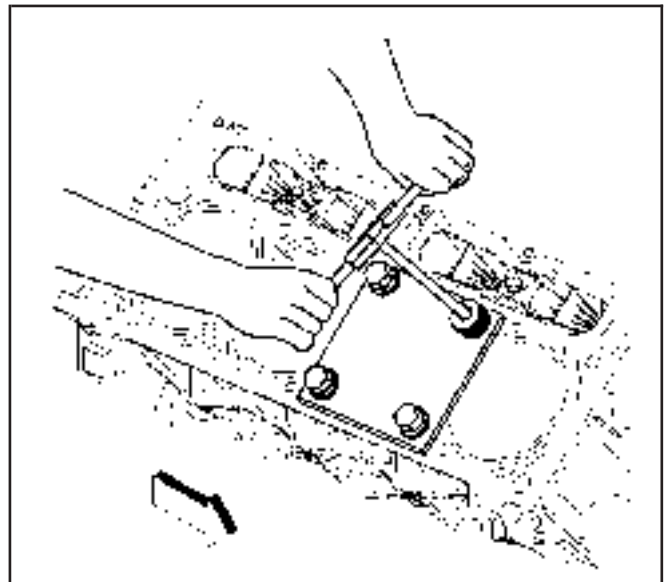
Important: During the reaming process, it is necessary to repeatedly remove the drill and clean the chips from the hole.

8. Drill out the threads of the damaged hole.
Drill the hole until the stop collar of the drill bit or the sleeve contacts the bushing.
9. Using compressed air, clean out any chips.



309861

10. Using a tap wrench, tap the threads of the drilled hole.



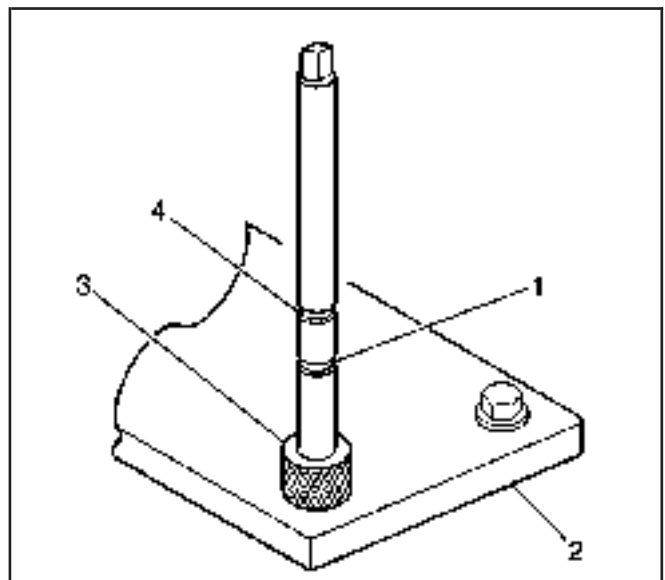
320667

11. In order to tap the new threads to the proper depth, rotate the tap into the hole until the marks (1 or 4) on the tap align with the top of the drill bushing (3).

For the deeper cylinder head bolt holes (1–8), rotate the tap until the upper mark on the tap (4) aligns with the top of the drill bushing.

For the shallower cylinder head bolt holes (9 and 10), rotate the tap until the lower mark on the tap (1) aligns with the top of the drill bushing.

12. Remove the fixture plate (2), bushing (3), and bolts.
13. Using compressed air, clean out any chips.
14. Spray cleaner GM P/N 12346139 (Canadian P/N 10953463), GM P/N 12377981 (Canadian P/N 10953463) or equivalent into the hole.

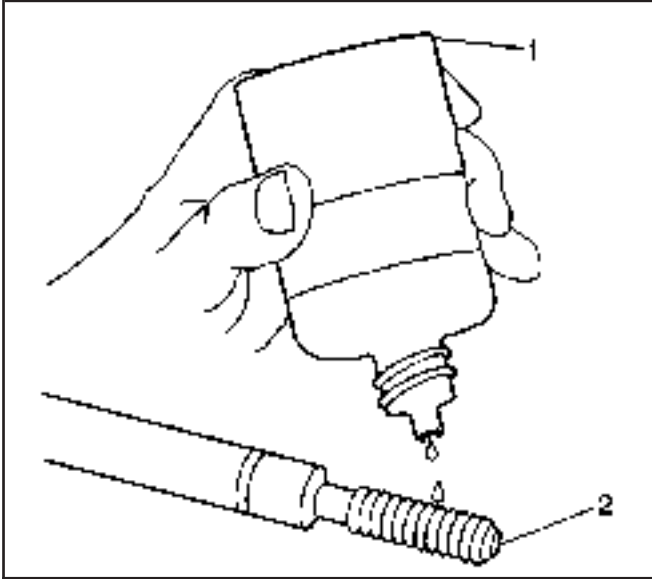


377637

- Using compressed air, clean any cutting oil and chips out of the hole.

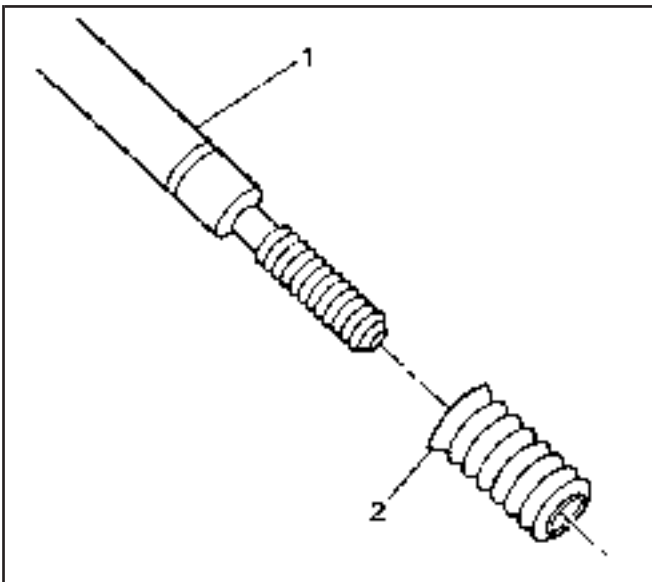
Important: Do not allow oil or other foreign material to contact the outside diameter (OD) of the insert.

- Lubricate the threads of the installer tool (2) with the driver oil (1).



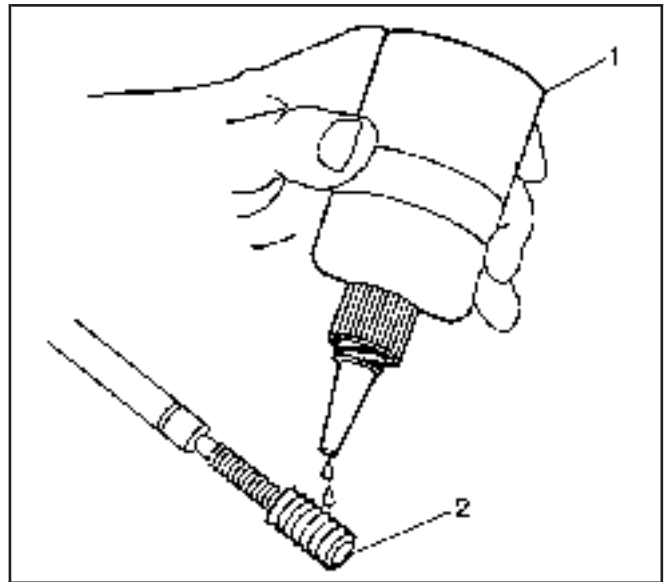
313562

- Install the insert (2) onto the driver tool (1).



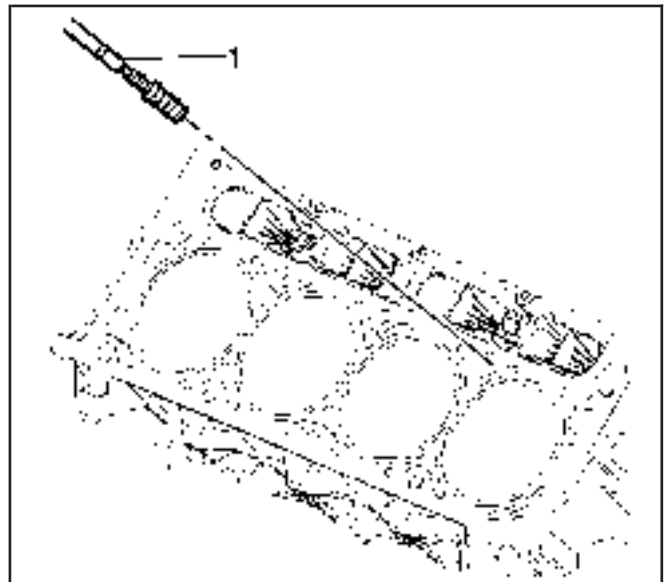
313567

18. Apply threadlock LOCTITE™ 277, J 42385-109 (1), or equivalent to the insert OD threads (2).

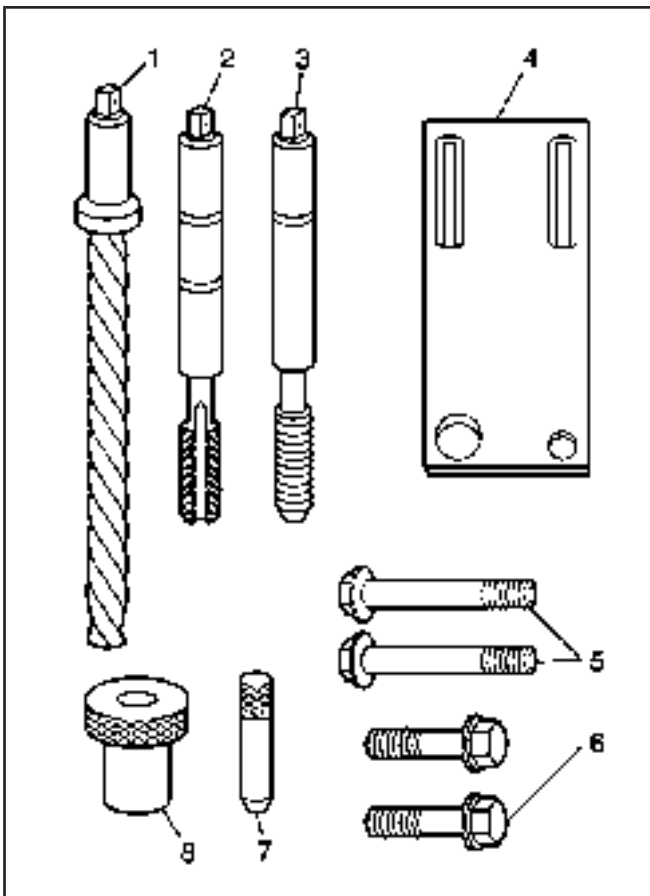


313572

19. Install the insert and driver (1) into the hole.
 Rotate the driver tool until the mark on the tool aligns with the deck surface of the engine block.
 The installer tool will tighten up before screwing completely through the insert. This is acceptable.
 You are forming the bottom threads of the insert and mechanically locking the insert to the base material threads.



320669

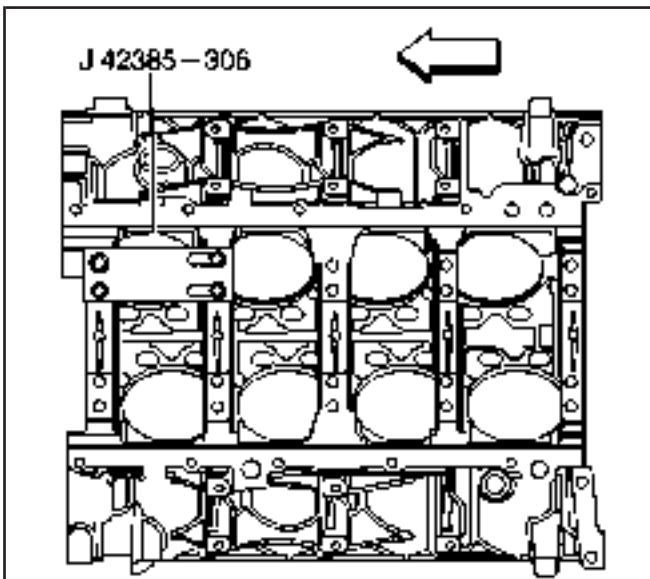


313556

Main Cap Bolt Hole Thread Repair

1. The main cap bolt hole thread repair kit consists of the following items:

- The drill (1)
- The tap (2)
- The installer (3)
- The fixture plate (4)
- The long bolts (5)
- The short bolts (6)
- The alignment pin (7)
- The bushing (8)



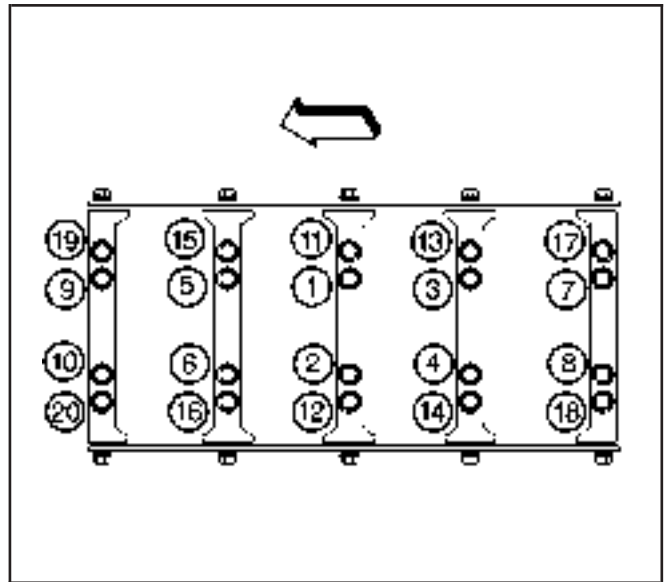
377630

2. Install the fixture plate, bolt, and bushing, onto the engine block.

Position the fixture plate and bushing over the hole that is to be repaired.

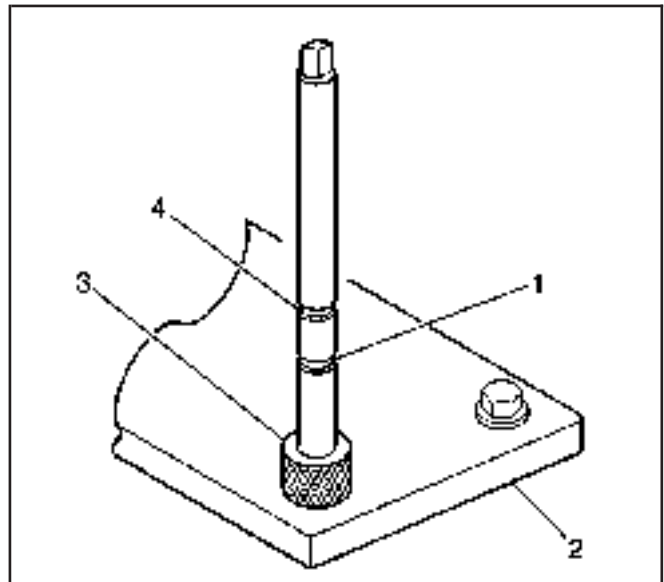
3. Position the alignment pin in the desired hole and tighten the fixture retaining bolts.

4. Drill out the damaged hole.
 The outer bolt hole locations (11–20) have the shallower counterbores. Use sleeve J 42385-316 with the drill.
 Drill until the stop collar of the drill bit or the sleeve contacts the bushing.
5. Using compressed air, clean out any chips.



63214

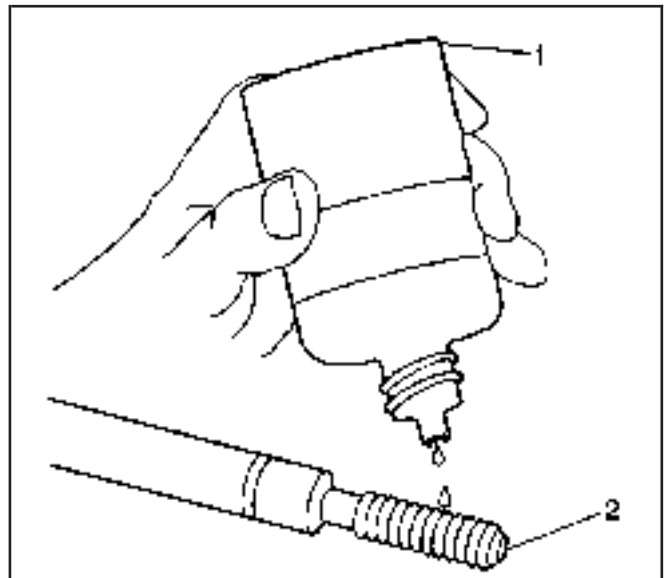
6. Using a tap wrench, tap the threads of the drilled hole.
 In order to tap the new threads to the proper depth, rotate the tap into the hole until the mark on the tap aligns with the top of the bushing.
 For the deeper main cap holes (1–10), rotate the tap until the upper mark (4) on the tap aligns with the top of the bushing (3).
 For the shallower main cap holes (11–20), rotate the tap until the lower mark (1) on the tap aligns with top of the bushing (3).
7. Using compressed air, clean out any chips.
8. Spray cleaner GM P/N 12346139 (Canadian P/N 10953463) or equivalent into the hole.
9. Using compressed air, clean any cutting oil and chips out of the hole.



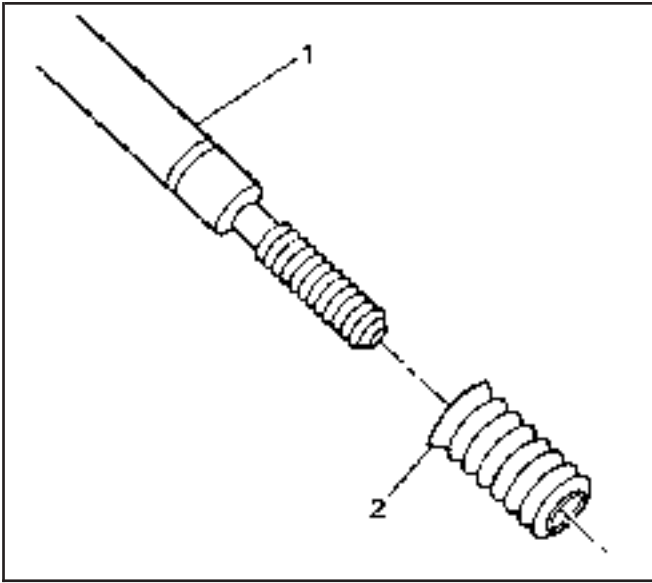
377637

Important: Do not allow oil or other foreign material to contact the outside diameter (OD) of the insert.

10. Lubricate the threads of the installer tool (2) with the driver oil (1).

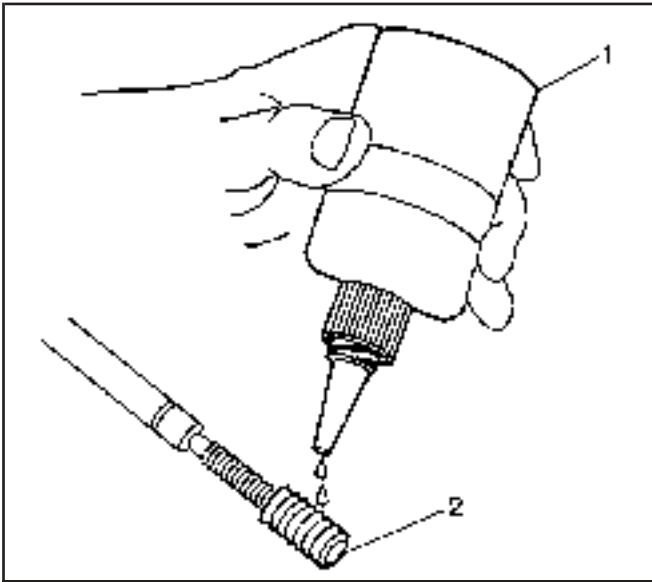


313562



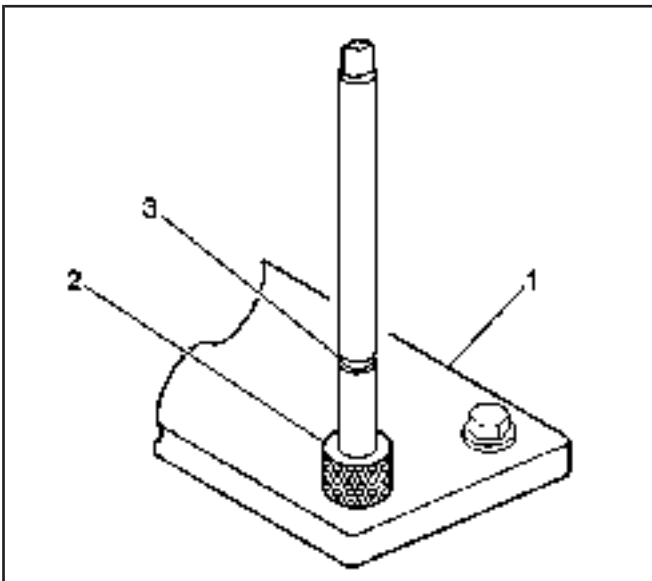
313567

11. Install the insert (2) onto the driver tool (1).



313572

12. Apply threadlock LOCTITE™ 277, J 42385-109 (1), or equivalent to the insert OD threads (2).



377635

Important: The fixture plate and bushing remains installed onto the engine block during the insert installation procedure.

13. Install the insert and driver (1) through the fixture plate and bushing and into the hole. Rotate the driver tool until the mark on the tool (3) aligns with the top of the bushing (2). The installer tool will tighten up before screwing completely through the insert. This is acceptable. You are forming the bottom threads of the insert and mechanically locking the insert to the base material threads.

Service Prior to Assembly

SIE-ID = 797195 LMD = 18-mar-2002

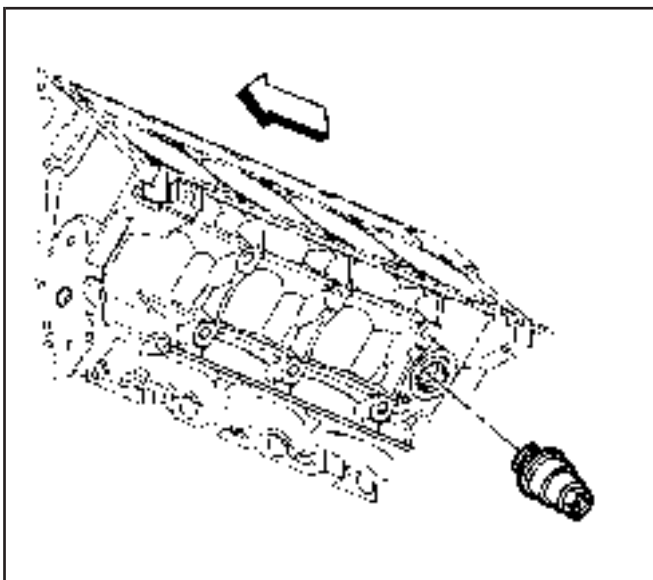
- Dirt or debris will cause premature wear of the rebuilt engine. Clean all the components. Refer to *Cleanliness and Care*.
- Use the proper tools to measure components when inspecting for excessive wear. Components that are not within the manufacturers specifications must be repaired or replaced.
- When the components are installed into an engine, return the components to their original location, position and direction. Refer to *Separating Parts*.
- During assembly, lubricate all the moving parts with clean engine oil. This will provide initial lubrication when the engine is first started.



863070



863255



260137

Engine Prelubing

SIE-ID = 863438 LMD = 10-jun-2002

Tools Required

J 45299 Engine Preluber

Notice: Refer to *Fastener Notice* in Cautions and Notices.

Important: A constant and continuous flow of clean engine oil is required in order to properly prime the engine. Be sure to use an approved engine oil as specified in the owners manual.

1. Remove the engine oil filter, fill with clean engine oil, and install the oil filter again.

Tighten

Tighten the oil filter to 30 N·m (22 lb ft).

2. Locate the engine block left front oil gallery plug (1).
 3. Install the M16 x 1.5 adapter P/N 509375.
 4. Install the flexible hose to the adapter and open the valve.
 5. Pump the handle on the J 45299 in order to flow a minimum of 1–1.9 liters (1–2 quarts) engine oil. Observe the flow of engine oil through the flexible hose and into the engine assembly.
 6. Close the valve and remove the flexible hose and adapter from the engine.
 7. Install the gallery plug to the engine.
- Tighten**
- Tighten the oil gallery plug to 60 N·m (44 lb ft).
8. Top-off the engine oil to the proper level.

Engine Block Plug Installation

SIE-ID = 823838 LMD = 18-mar-2002

Tools Required

J 41712 Oil Pressure Switch Socket

Important:

- Engine block plug, oil gallery and coolant, sealing washers may be used again if they are not bent, scored or otherwise damaged.
- Apply the proper amount and type of sealant to the sealing washer as recommended in the service procedure.

1. Apply a 3.175 mm (0.125 in) bead of sealant GM P/N 12346004 (Canadian P/N 10953480) or equivalent to the engine block coolant heater sealing washer, if applicable. Refer to *Sealers, Adhesives, and Lubricants*.

Notice: Refer to *Fastener Notice* in Cautions and Notices.

2. Install the engine block coolant heater to the engine block, if applicable.

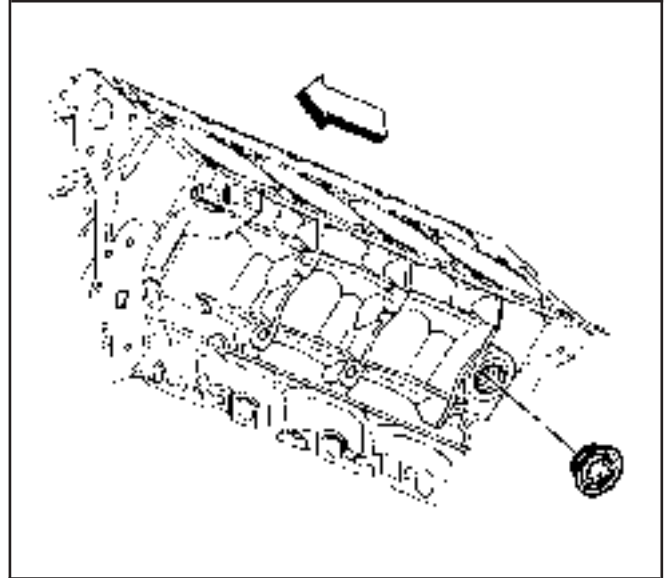
Tighten

Tighten the block coolant heater to 40 N·m (30 lb ft).

3. Apply a 3.175 mm (0.125 in) bead of sealant GM P/N 12346004 (Canadian P/N 10953480) or equivalent to the engine block left rear coolant drain plug sealing washer, if applicable.
4. Install the engine block left rear coolant drain plug, if applicable.

Tighten

Tighten the block left rear coolant drain plug to 60 N·m (44 lb ft).

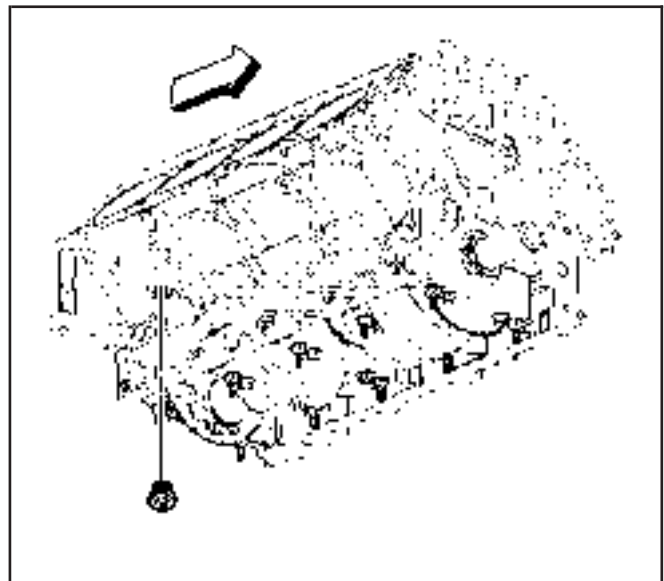


260138

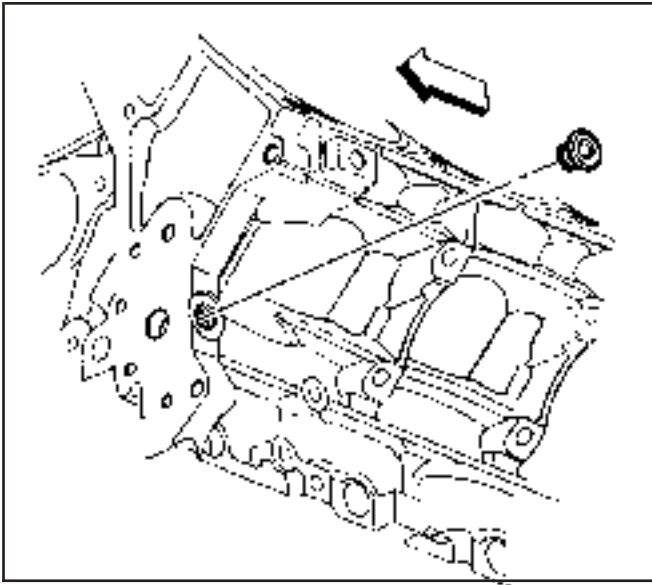
5. Apply a 3.175 mm (0.125 in) bead of sealant GM P/N 12346004 (Canadian P/N 10953480) or equivalent to the engine block right rear coolant drain plug sealing washer.
6. Install the engine block right rear coolant drain plug.

Tighten

Tighten the block right rear coolant drain plug to 60 N·m (44 lb ft).



63164

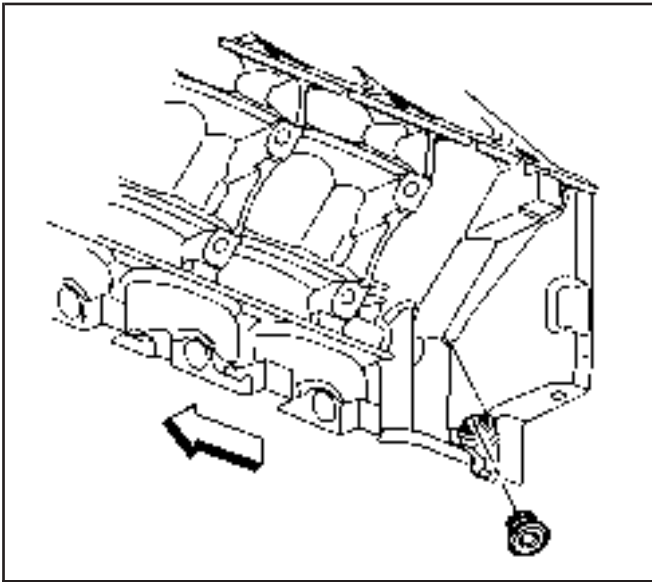


260139

7. Apply a 3.175 mm (0.125 in) bead of sealant GM P/N 12346004 (Canadian P/N 10953480) or equivalent to the engine block left front oil gallery plug sealing washer.
8. Install the engine block left front oil gallery plug.

Tighten

Tighten the block left front oil gallery plug to 60 N·m (44 lb ft).



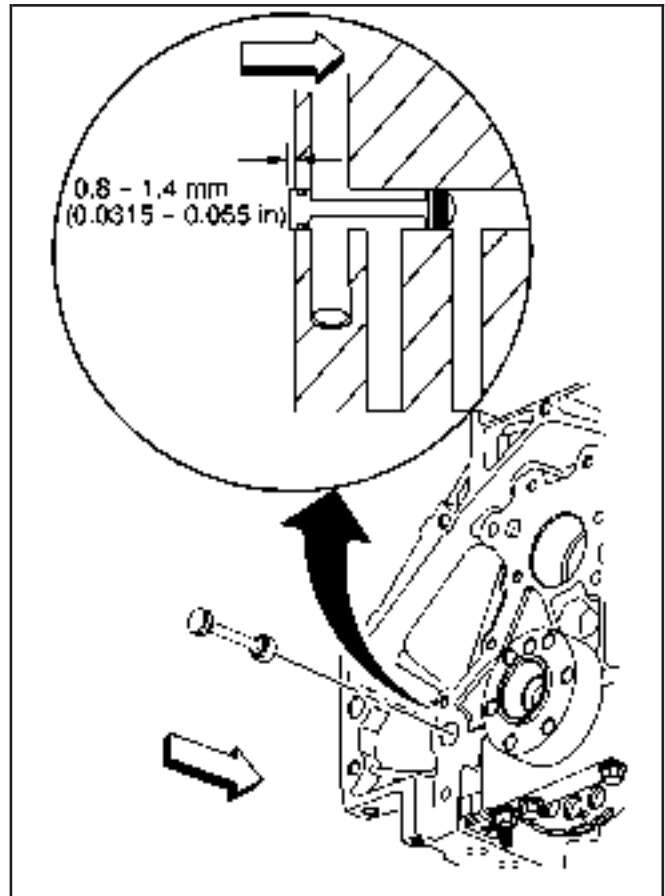
64923

9. Apply a 3.175 mm (0.125 in) bead of sealant GM P/N 12346004 (Canadian P/N 10953480) or equivalent to the engine block left rear oil gallery plug sealing washer.
10. Install the engine block left rear oil gallery plug.

Tighten

Tighten the block left rear oil gallery plug to 60 N·m (44 lb ft).

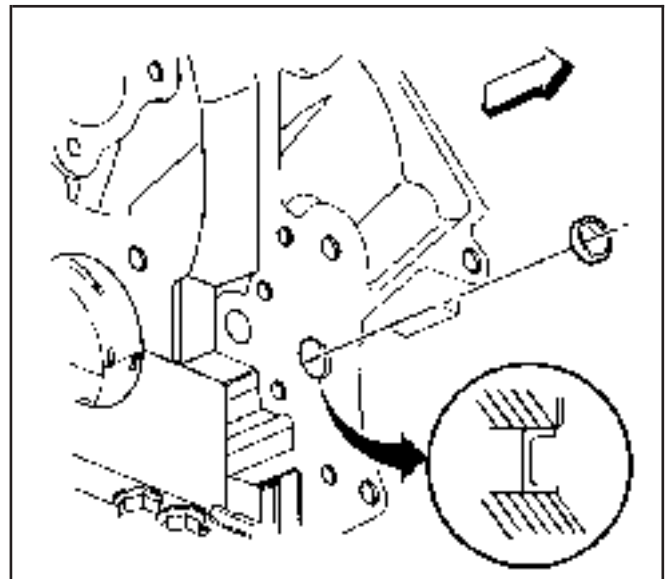
11. Inspect the engine block rear oil gallery plug and O-ring seal. If the O-ring seal on the plug is not cut or damaged, the rear oil gallery plug may be used again.
12. Lubricate the O-ring seal with clean engine oil.
13. Install the block rear oil gallery plug into the oil gallery bore. A properly installed block plug will protrude 0.8–1.4 mm (0.0315–0.055 in) beyond the rear face of the block.



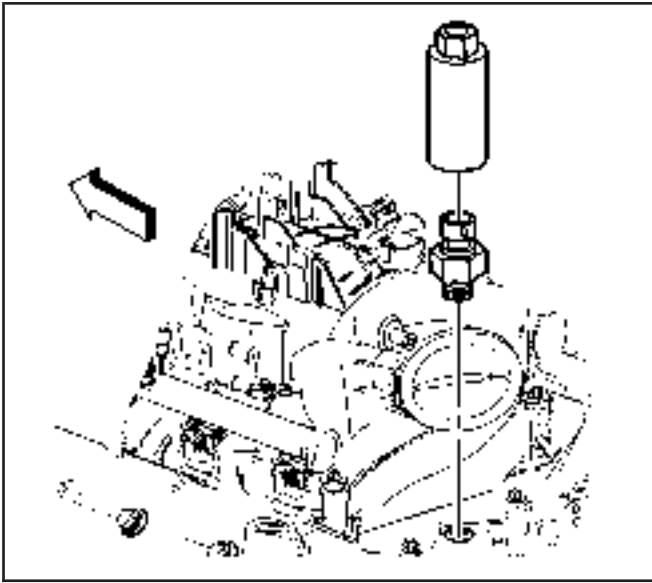
63228

Important: The engine block front oil gallery plug should not be removed unless service is required.

14. Apply sealant GM P/N 12345382 (Canadian P/N 10953489) or equivalent to the sides of the NEW front oil gallery plug.
15. Install a NEW engine block front oil gallery plug, if required. Install the front oil gallery plug into the oil gallery bore 2.2–2.8 mm (0.0086–0.011 in) below flush.



64295

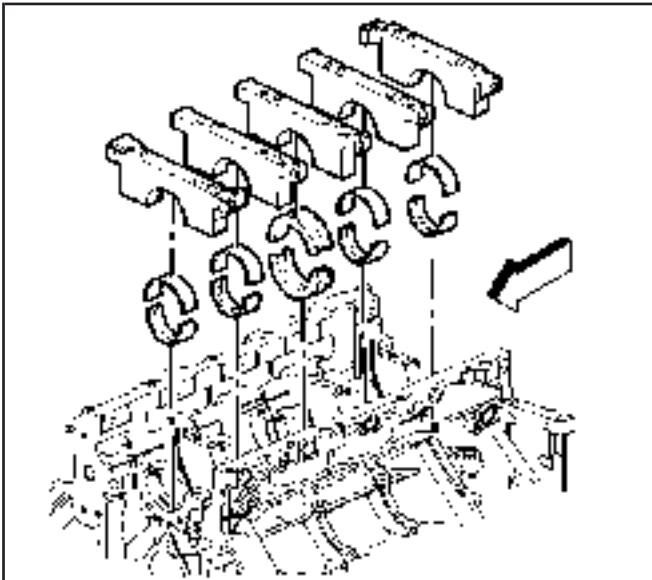


823316

16. Apply sealant GM P/N 12346004 (Canadian P/N 10953480) or equivalent to the threads of the oil pressure sensor.
17. Use the *J 41712* or equivalent in order to install the oil pressure sensor.

Tighten

Tighten the oil pressure sensor to 20 N·m (15 lb ft).



64293

Crankshaft and Bearings Installation

SIE-ID = 73768 LMD = 11-may-2001

Tools Required

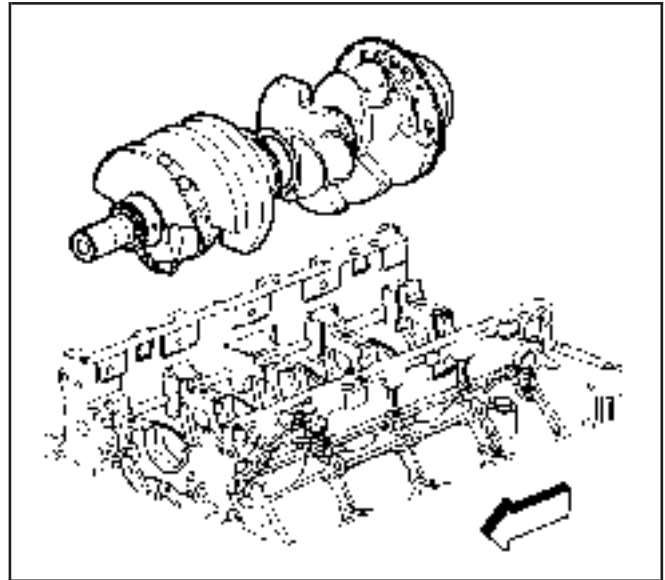
J 36660-A Torque Angle Meter

Important:

- Crankshaft bearing clearances are critical. Excessive crankshaft bearing clearance may effect crankshaft position sensor signals and/or On-Board Diagnostics (OBD) II system performance.
 - Crankshaft bearing caps must be installed to the proper location and direction.
 - When installing the crankshaft bearings, align the locating tabs on the bearings with the locating notches in the engine block journal bore and the bearing cap.
 - Always install crankshaft bearings with their machined partner. Do not file bearings or mix bearing halves.
 - To prevent engine block oil leakage, install NEW M8 crankshaft bearing cap side bolts. The crankshaft bearing cap M8 side bolts have a sealant patch applied to the bolt flange.
1. Install the crankshaft thrust bearings to the engine block and center bearing cap.
 2. Install the remaining crankshaft bearings to the engine block and bearing caps.
 3. Lubricate the bearing surfaces and crankshaft journals with clean engine oil.

Notice: SIO-ID = 312770 LMD = 10-sep-1997 To maintain proper crankshaft end play, use extreme care during crankshaft installation. Avoid scoring or damaging the thrust bearing.

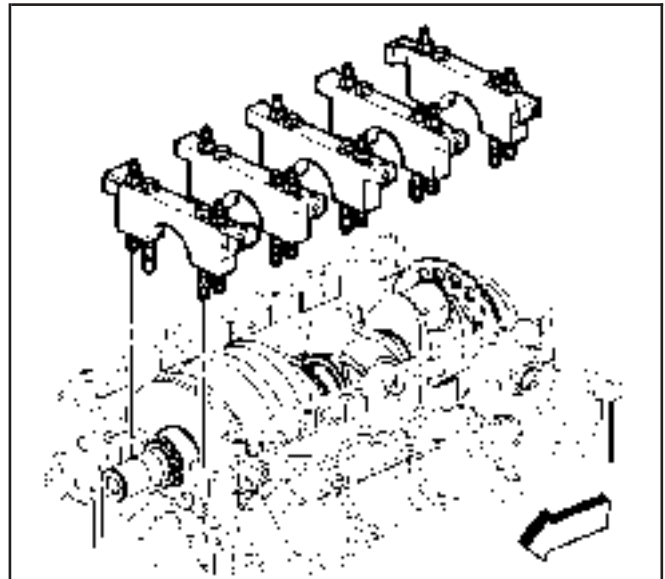
4. Install the crankshaft.



156151

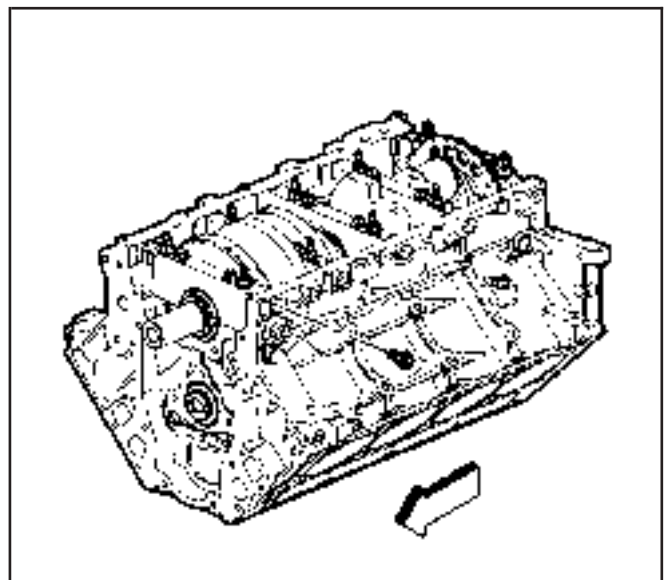
Important: The bearing caps must be installed in the proper location and direction.

5. Install the crankshaft bearing caps, with bearings, into the engine block.
6. Start the M10 bolts and bolt/studs.
7. Tap the bearing caps into place with a plastic-faced hammer.

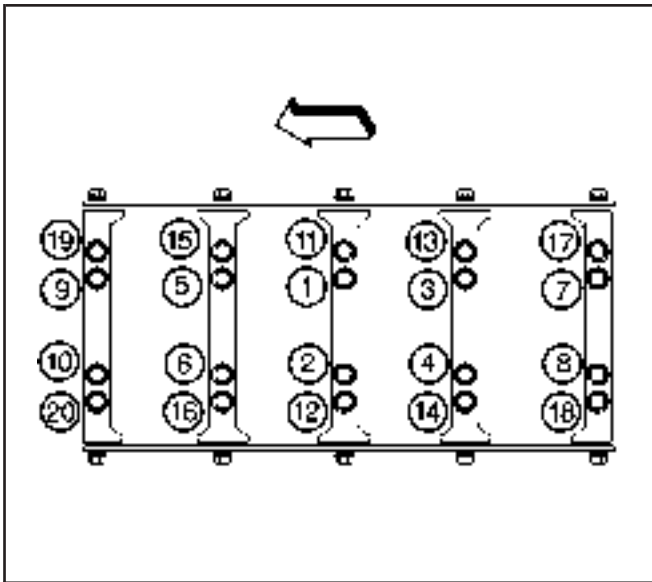


156152

8. Install the NEW M8 bearing cap side bolts.



156155



63214

Notice: Refer to *Fastener Notice* in Cautions and Notices.

9. Tighten the bearing cap bolts and studs.

Tighten

Tighten the inner M10 bearing cap bolts first pass in sequence to 20 N·m (15 lb ft).

Important: To properly align the crankshaft thrust bearings, the final thrust of the crankshaft **MUST** be in the forward direction.

10. Using a plastic faced hammer, tap the crankshaft rearward then forward to align the thrust bearings.

Tighten

- 10.1. Tighten the inner M10 bolts final pass in sequence 80 degrees using the *J 36660-A*.
- 10.2. Tighten the outer M10 bolts/studs first pass in sequence to 20 N·m (15 lb ft).
- 10.3. Tighten the outer M10 bolts/studs final pass in sequence 53 degrees using the *J 36660-A*.
- 10.4. Tighten the bearing cap side M8 bolts to 25 N·m (18 lb ft).

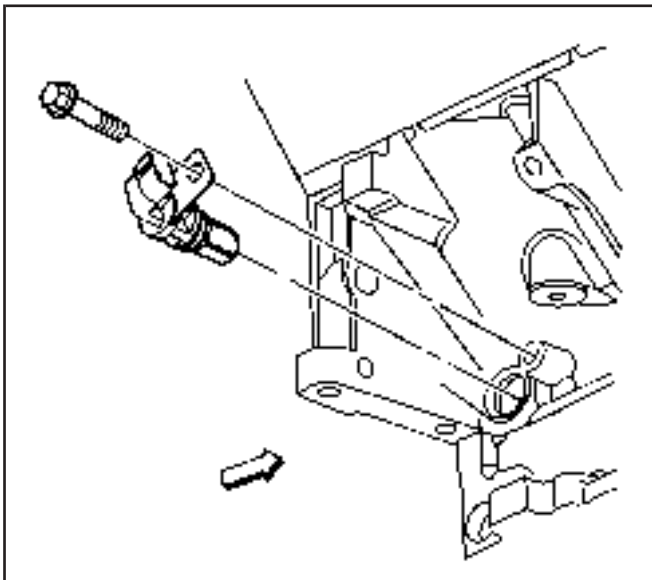
Tighten the bolt on one side of the bearing cap and then tighten the bolt on the opposite side of the same bearing cap.

11. Install the crankshaft position sensor.

- 11.1. Inspect the crankshaft position sensor O-ring seal. If the O-ring seal is not cut or damaged, it may be used.
- 11.2. Coat the O-ring seal with clean engine oil.
- 11.3. Install the sensor. Align the notch in the sensor retaining bracket with the bolt hole in the block.
- 11.4. Install the sensor bolt.

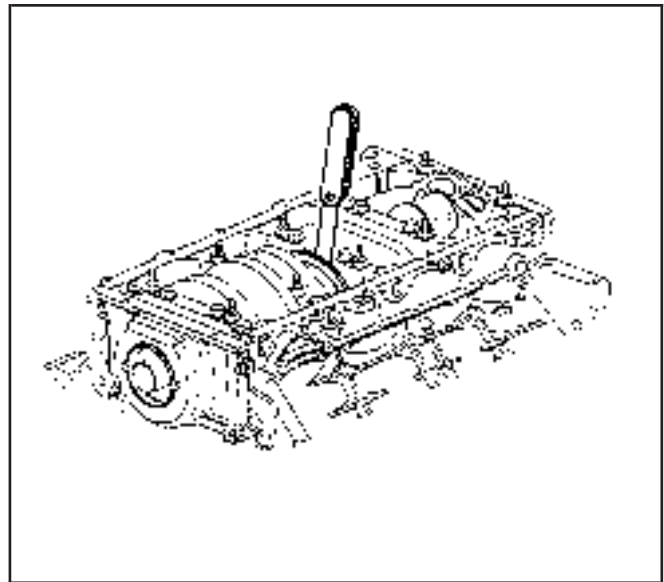
Tighten

Tighten the crankshaft position sensor bolt to 25 N·m (18 lb ft).



55322

12. Measure the crankshaft end play.
 - 12.1. Thrust the crankshaft forward or rearward.
 - 12.2. Insert a feeler gage between the center crankshaft bearing and the bearing surface of the crankshaft and measure the bearing clearance.
 The proper crankshaft end play clearance is 0.04–0.2 mm (0.0015–0.0078 in).
 - 12.3. If the bearing clearance is not within specifications, inspect the thrust surfaces for nicks, gouges or raised metal. Minor imperfections may be removed with a fine stone.



64316

Piston, Connecting Rod, and Bearing Installation

SIE-ID = 823839 LMD = 22-mar-2002

Tools Required

- J 8037 Piston Ring Compressor
- J 36660-A Torque Angle Meter
- J 41556 Connecting Rod Guide

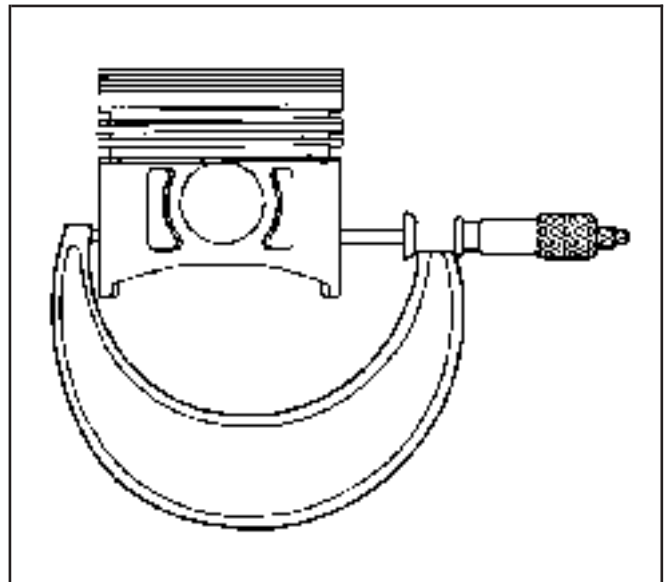
Piston Selection

Important: Measurements of all components should be taken with the components at normal room temperature.

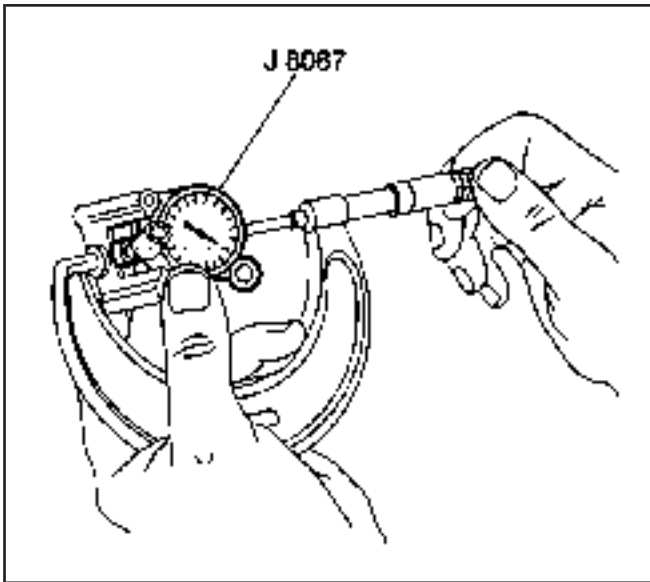
For proper piston fit, the engine block cylinder bores must not have excessive wear or taper.

A used piston and pin set may be installed if, after cleaning and inspection, they are within specifications.

1. Inspect the engine block cylinder bore for scoring or other damage.
2. Inspect the piston and the piston pin. Refer to *Piston, Connecting Rod, and Bearings Cleaning and Inspection*.
3. With the micrometer at a right angle to the piston, measure the piston. Measure 4.8L and 5.3L pistons 43 mm (1.69 in) from the crown. Refer to *Piston, Connecting Rod, and Bearings Cleaning and Inspection*.
4. Record the piston diameter.

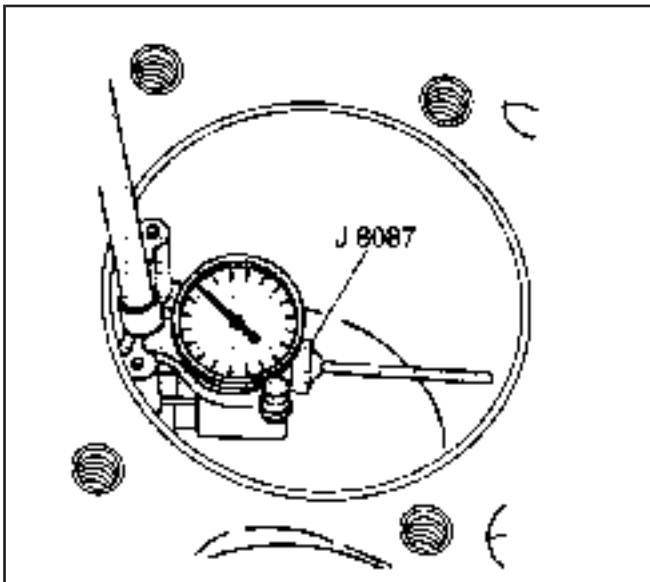


188016



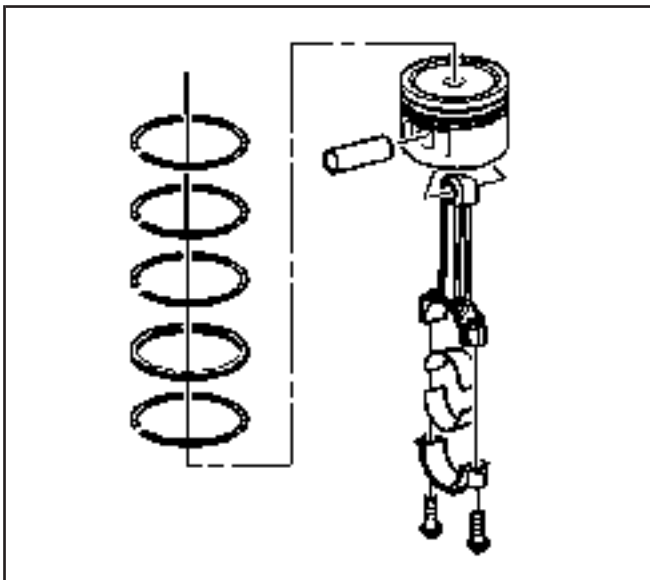
4974

5. Adjust the micrometer to the recorded piston diameter.
6. Insert the bore gage into the micrometer and zero the bore gage dial.



4972

7. Use a bore gage and measure the cylinder bore diameter. Measure at a point 64 mm (2.5 in) from the top of the cylinder bore.
8. Record the cylinder bore diameter.
9. Subtract the piston diameter from the cylinder bore diameter in order to determine the piston-to-bore clearance. Refer to *Engine Mechanical Specifications (LR4 VIN V)* or *Engine Mechanical Specifications (LM7 VIN T)* or *Engine Mechanical Specifications (L59 VIN Z)* or *Engine Mechanical Specifications (LQ4 VIN U)* or *Engine Mechanical Specifications (LQ9 VIN N)*.
10. If the proper clearance cannot be obtained, select another piston and measure the clearances. If the proper fit cannot be obtained, the cylinder bore may require boring and honing for an oversize piston or engine block replacement.



64180

Installation Procedure

Important: The piston and cylinder bore have been measured and the bore has been sized for the proper clearance. Install the piston and connecting rod assembly into the proper cylinder bore.

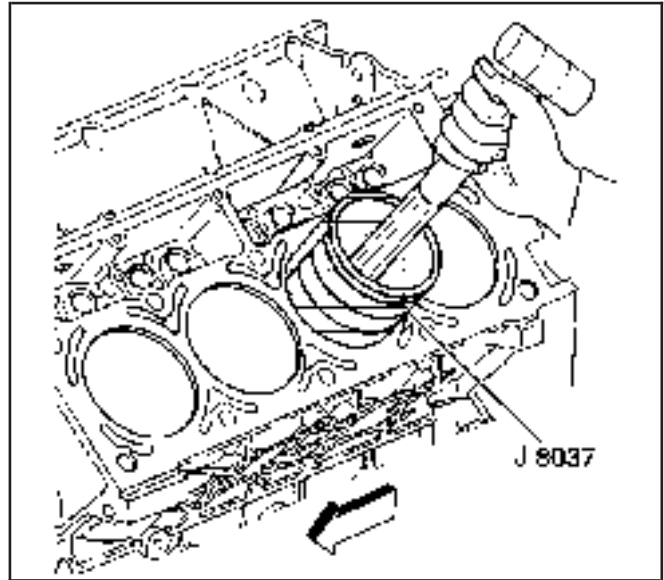
The piston alignment mark **MUST** face the front of the engine block.

1. Lightly lubricate the following components with clean engine oil:
 - The piston
 - The piston rings
 - The cylinder bore
 - The bearing surfaces
2. Stagger the oil control ring end gaps a minimum of 90 degrees.
3. Stagger the compression ring end gaps a minimum of 25 mm (1.0 in).

4. Install the *J 41556* to the connecting rod.
5. Install the *J 8037* onto the piston and compress the piston rings.

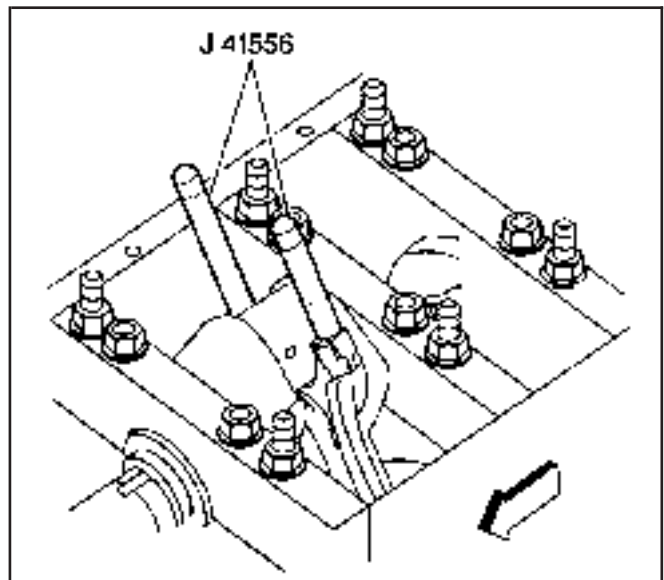
Important: The piston alignment mark MUST facing the front of the engine block.

6. Install the piston and connecting rod assembly into the proper cylinder bore.
 - 6.1. Hold the piston ring compressor firmly against the engine block. Using a wooden hammer handle, lightly tap the top of the piston until all of the piston rings enter the cylinder bore.
 - 6.2. Use the *J 41556* to guide the connecting rod end onto the crankshaft journal.

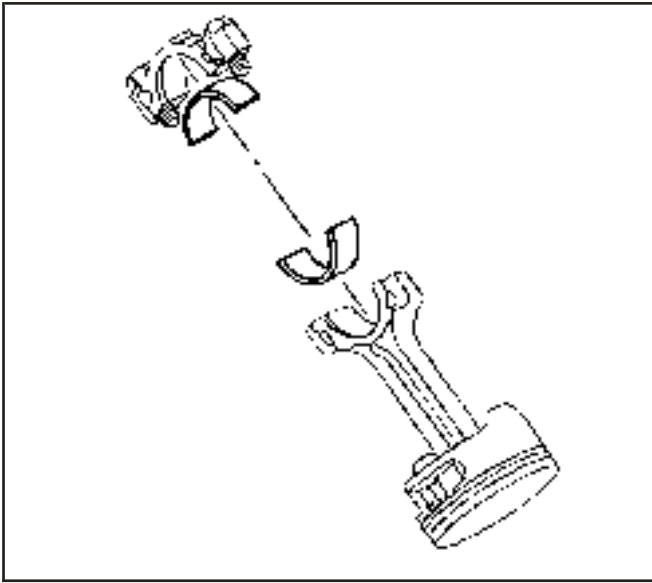


63217

7. Remove the *J 41556*.



63186



53223

Notice: Refer to *Fastener Notice* in Cautions and Notices.

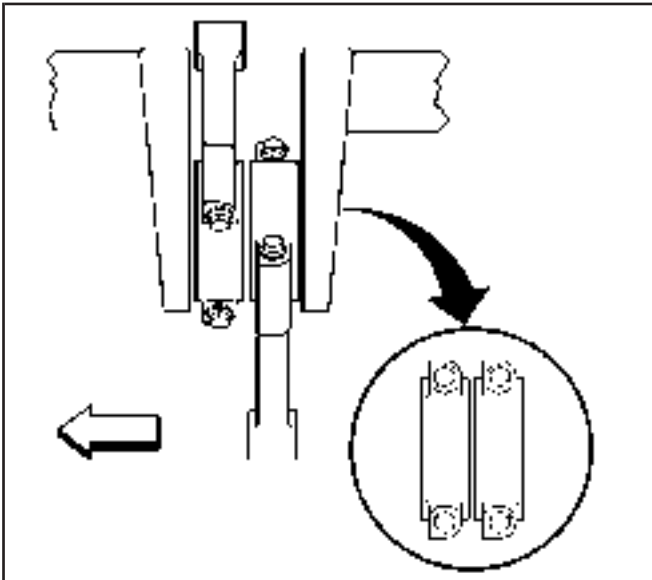
Important: Position the connecting rod cap onto the connecting rod properly.

Align the flat side of the connecting rod cap with the flat side of the connecting rod.

8. Install the bearing, cap, and bolts.

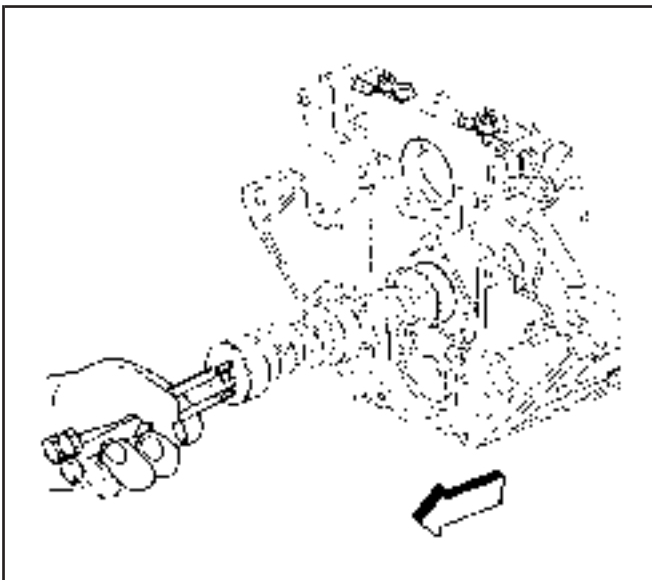
Tighten

- 8.1. Tighten the bolts a first pass evenly to 20 N·m (15 lb ft).
- 8.2. Tighten the bolts a final pass to 75 degrees using the *J 36660-A*.



63227

9. Inspect the connecting rods for proper orientation onto the crankshaft journal.
10. With the pistons and connecting rods installed, use a soft faced mallet and lightly tap each connecting rod assembly parallel to the crankpin to make sure that the rods have side clearance.
11. Measure the connecting rod side clearance using a feeler gage or a dial indicator. Connecting rod side clearance should be within 0.11–0.51 mm (0.0043–0.02 in).



63212

Camshaft Installation

SIE-ID = 73770 LMD = 01-apr-2002

Important: If camshaft replacement is required, the valve lifters must also be replaced.

1. Lubricate the camshaft journals and the bearings with clean engine oil.
2. Install 3 M8 – 1.25 x 100 mm (M8 – 1.25 x 4.0 in) bolts into the camshaft front bolt holes.

Notice: SIO-ID = 13833 LMD = 03-feb-1998 All camshaft journals are the same diameter, so care must be used in removing or installing the camshaft to avoid damage to the camshaft bearings.

3. Using the bolts as a handle, carefully install the camshaft into the engine block.
4. Remove the 3 bolts from the front of the camshaft.

Notice: Refer to *Fastener Notice* in Cautions and Notices.

Important: Install the retainer plate with the sealing gasket facing the engine block.

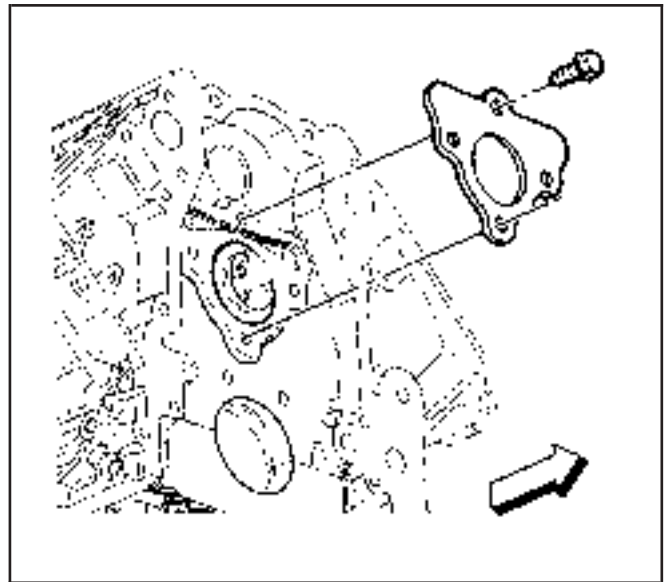
The gasket surface on the engine block should be clean and free of dirt or debris.

5. Install the camshaft retainer and the bolts.

Tighten

Tighten the camshaft retainer bolts to 25 N·m (18 lb ft).

6. Inspect the camshaft sensor O-ring seal. If the O-ring seal is not cut or damaged, it may be used again.
7. Lubricate the O-ring seal with clean engine oil.

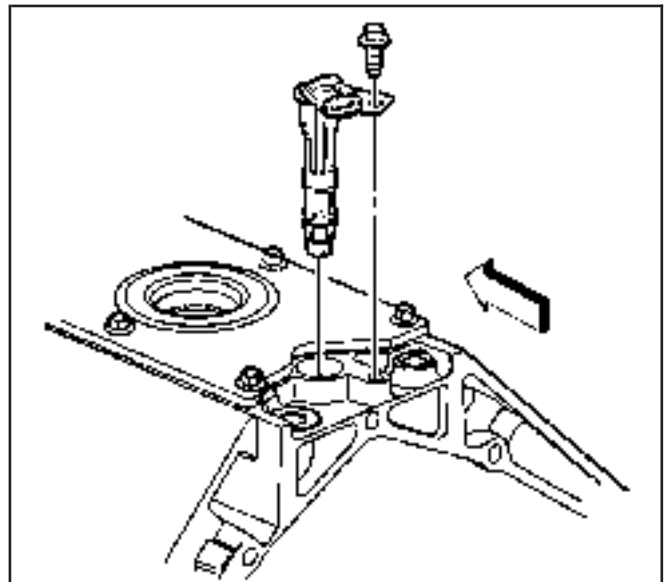


63211

8. Install the camshaft sensor and bolt.

Tighten

Tighten the camshaft sensor bolt to 25 N·m (18 lb ft).



260128

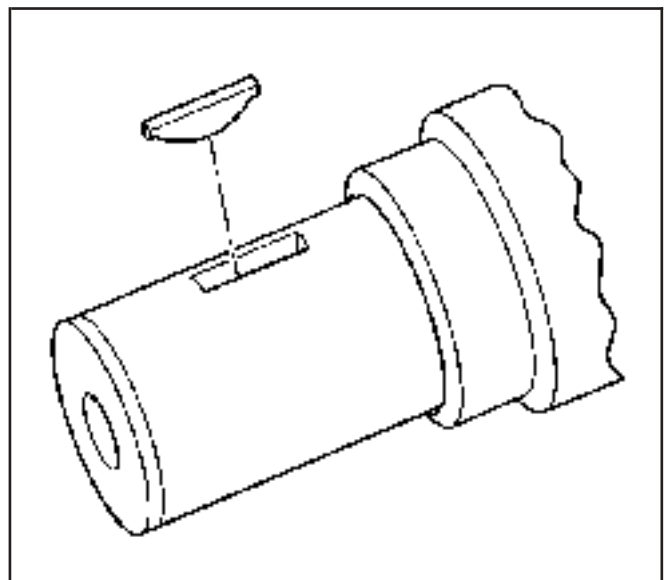
Timing Chain and Sprockets Installation

SIE-ID = 73771 LMD = 01-oct-2001

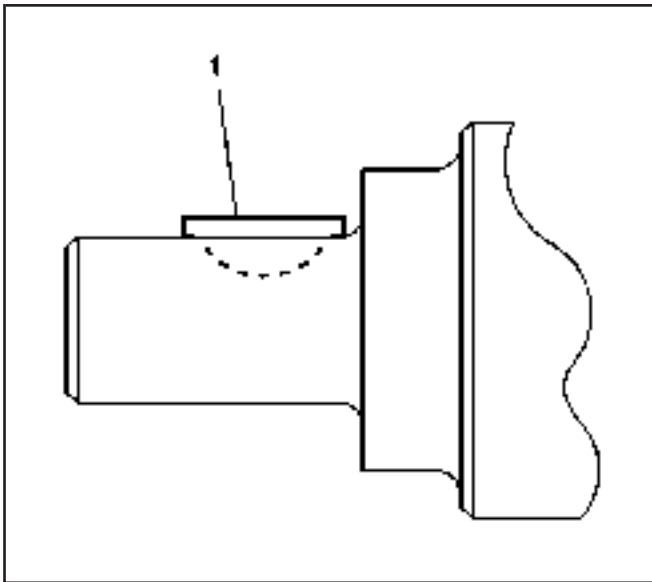
Tools Required

J 41665 Crankshaft Balancer and Sprocket Installer

1. Install the key into the crankshaft keyway, if previously removed.

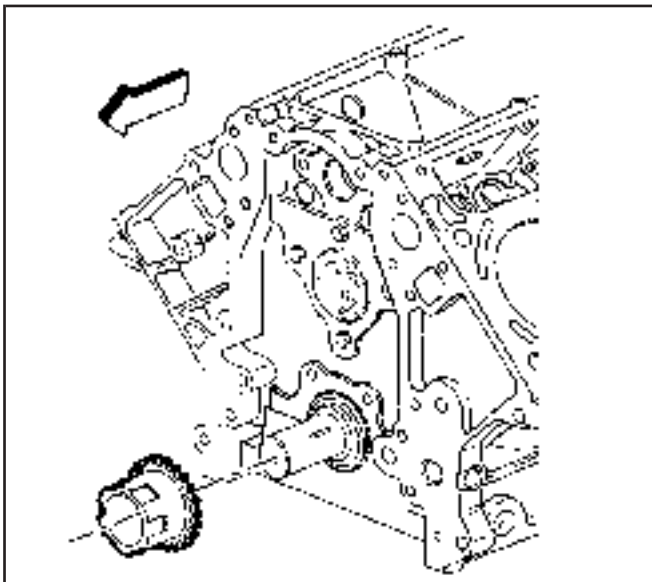


156149



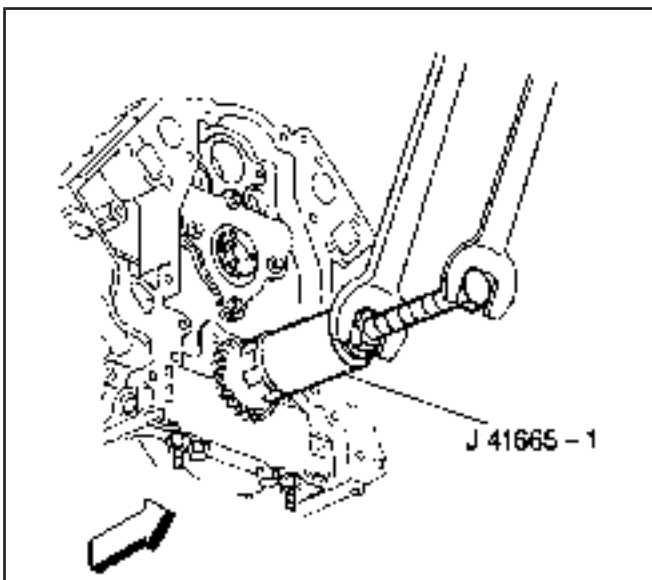
490871

2. Tap the key (1) into the keyway until both ends of the key bottom onto the crankshaft.



156150

3. Install the crankshaft sprocket onto the front of the crankshaft. Align the crankshaft key with the crankshaft sprocket keyway.



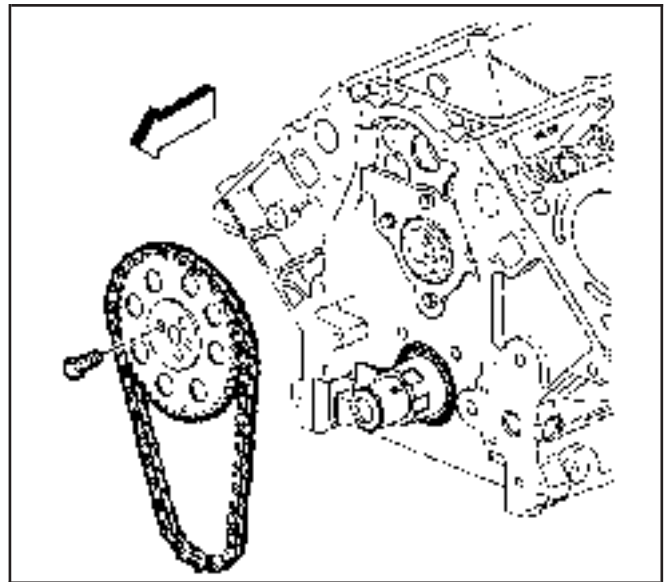
63199

4. Use the *J 41665* in order to install the crankshaft sprocket.
Install the sprocket onto the crankshaft until fully seated against the crankshaft flange.
5. Rotate the crankshaft sprocket until the alignment mark is in the 12 o'clock position.

Important:

- Properly locate the camshaft sprocket locating pin with the camshaft sprocket alignment hole.
- The sprocket teeth and timing chain must mesh.
- The camshaft and the crankshaft sprocket alignment marks **MUST** be aligned properly.
Locate the camshaft sprocket alignment mark in the 6 o'clock position.

6. Install the camshaft sprocket and timing chain.



63263

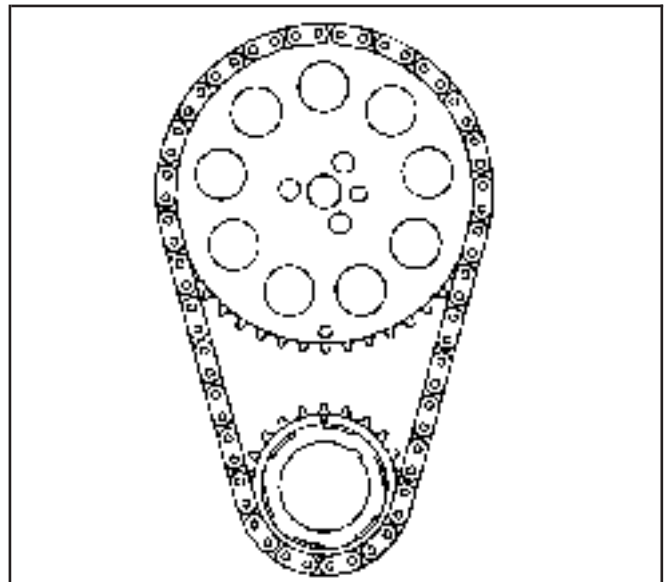
7. If necessary, rotate the camshaft or crankshaft sprockets in order to align the timing marks.

Notice: Refer to *Fastener Notice* in Cautions and Notices.

8. Install the camshaft sprocket bolts.

Tighten

Tighten the camshaft sprocket bolts to 35 N·m (26 lb ft).



156158

Oil Pump, Pump Screen and Deflector Installation

SIE-ID = 281423 LMD = 24-jul-1998

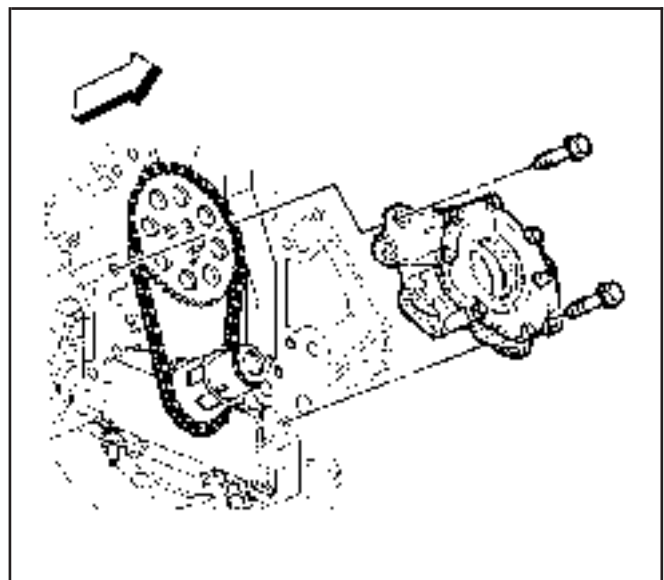
Important: Inspect the oil pump and engine block oil gallery passages. These surfaces must be clear and free of debris or restrictions.

1. Align the splined surfaces of the crankshaft sprocket and the oil pump drive gear and install the oil pump.
2. Install the oil pump onto the crankshaft sprocket until the pump housing contacts the face of the engine block.

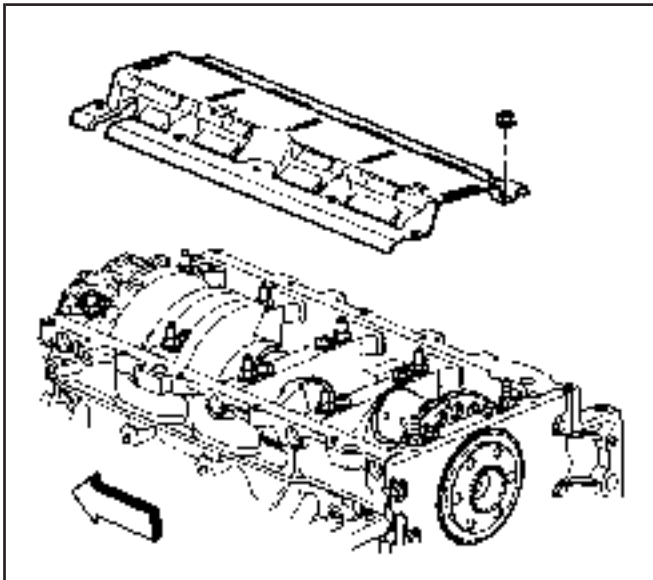
Notice: Refer to *Fastener Notice* in Cautions and Notices.

3. Install the oil pump bolts.

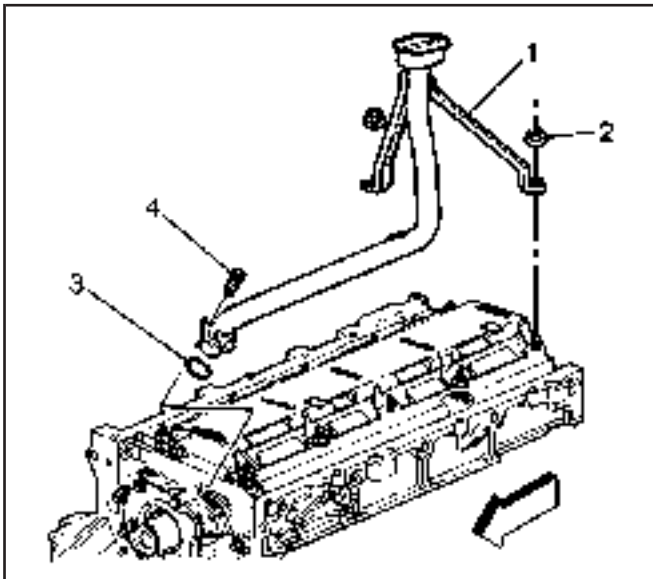
Tighten



64281



260099



260109

- Tighten the oil pump bolts to 25 N·m (18 lb ft).
4. Install the crankshaft oil deflector.

5. Lubricate a NEW oil pump screen O-ring seal (3) with clean engine oil.
6. Install the NEW O-ring seal onto the oil pump screen.

Important: Push the oil pump screen tube completely into the oil pump prior to tightening the bolt. Do not allow the bolt to pull the tube into the pump.

Align the oil pump screen mounting brackets with the correct crankshaft bearing cap studs.

7. Install the oil pump screen (1).
8. Install the oil pump screen bolt (4) and the deflector nuts (2).

Tighten

- 8.1. Tighten the oil pump screen bolt (4) to 12 N·m (106 lb in).
- 8.2. Tighten the crankshaft oil deflector nuts (2) to 25 N·m (18 lb ft).

Engine Rear Cover Installation

SIE-ID = 186411 LMD = 13-mar-2002

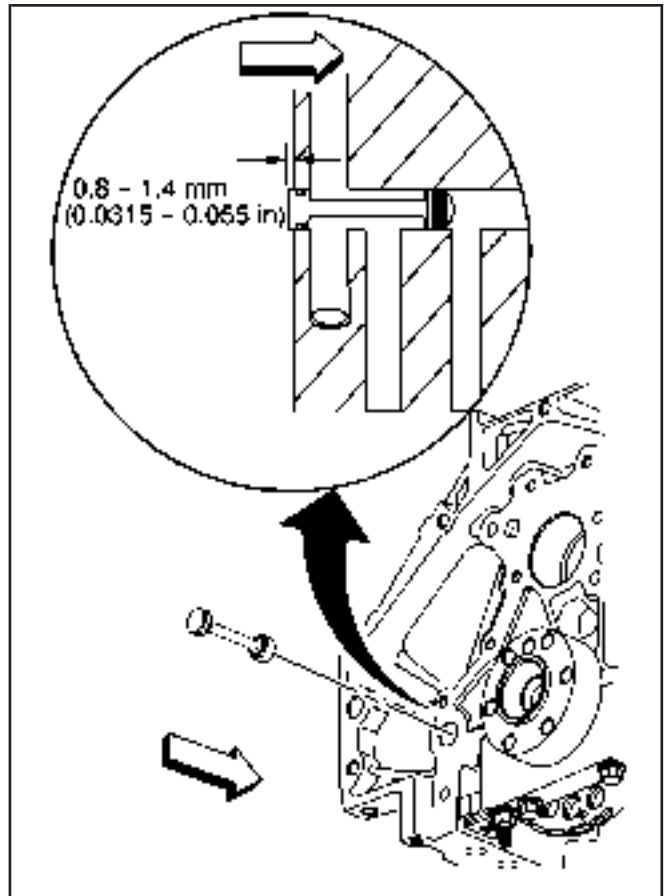
Tools Required

- J 41480 Front/Rear Cover Alignment – Oil Pan Surface
- J 41476 Front/Rear Cover Alignment – Crankshaft Oil Seal Area

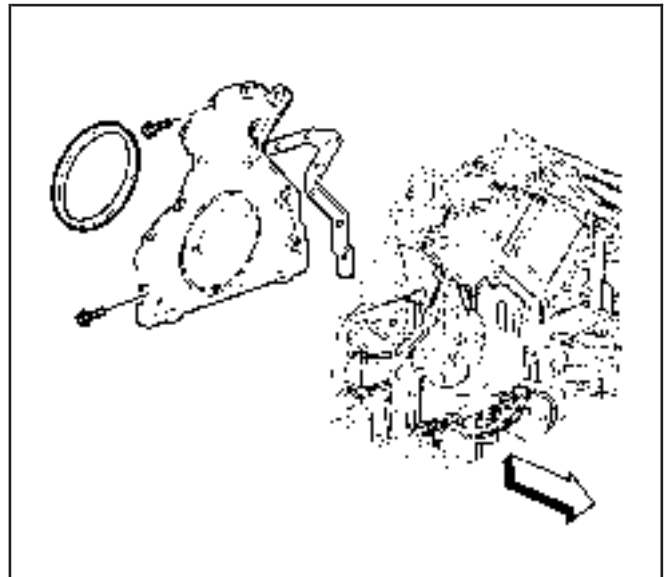
Important:

- Do not use the crankshaft rear oil seal or the engine rear cover gasket again.
- Do not apply any type sealant to the rear cover gasket, unless specified.
- The special tools in this procedure are used to properly align the engine rear cover at the oil pan surface and to center the crankshaft rear oil seal.
- The crankshaft rear oil seal will be installed after the rear cover has been installed and aligned. Install the rear cover without the crankshaft oil seal.
 - The crankshaft rear oil seal **MUST** be centered in relation to the crankshaft.
 - The oil pan sealing surface at the rear cover and engine block **MUST** be aligned within specifications.
 - An improperly aligned rear cover may cause premature rear oil seal wear and/or engine assembly oil leaks.

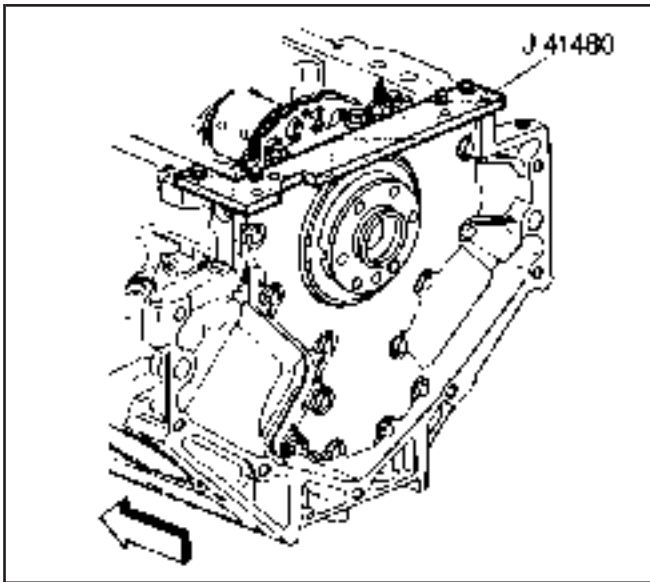
1. Inspect the rear oil gallery plug for proper installation.
2. Install the rear cover gasket, rear cover and bolts.
3. Tighten the bolts finger tight. Do not overtighten.



63228



64282



64204

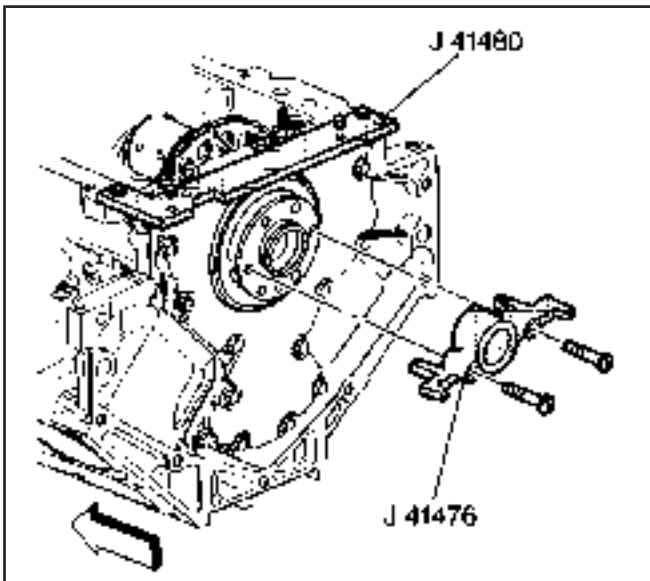
Notice: Refer to *Fastener Notice* in Cautions and Notices.

Important: Start the *J 41480* tool-to-rear cover bolts. Do not tighten the bolts at this time.

4. Install the *J 41480* and bolts.

Tighten

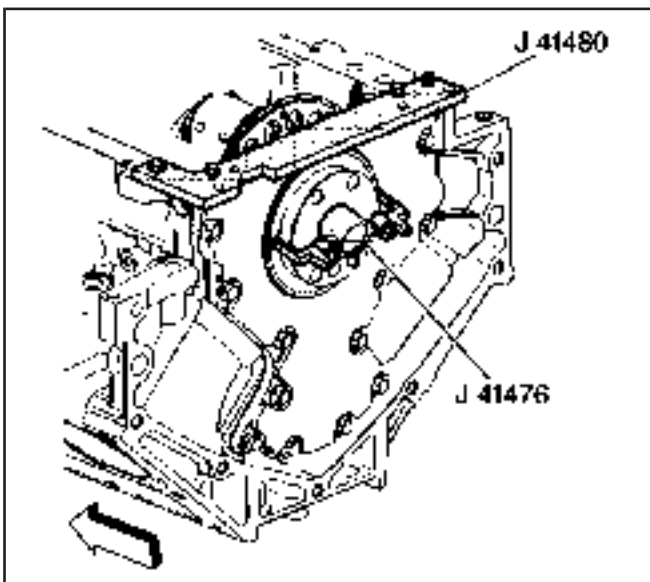
Tighten the tool-to-engine block bolts to 25 N·m (18 lb ft).



63243

Important: To properly align the rear cover, the *J 41476* must be installed onto the rear of the crankshaft with the tool mounting bolts parallel to the oil pan surface.

5. Rotate the crankshaft until 2 opposing flywheel bolt holes are parallel to the oil pan surface.



65286

Important: The tapered legs of the alignment tool must enter the rear cover oil seal bore.

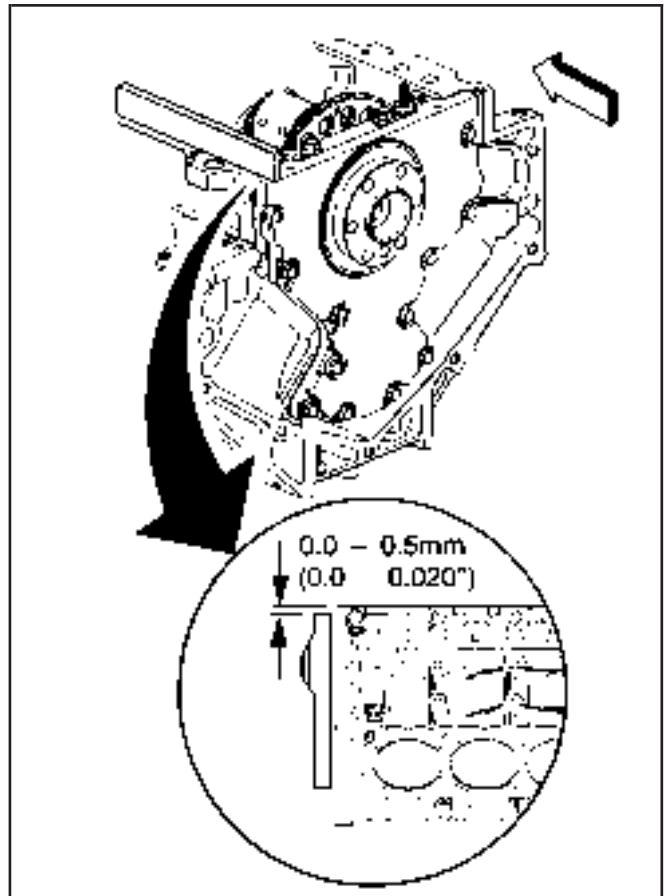
6. Install the *J 41476* and bolts onto the rear of the crankshaft.

Tighten

- 6.1. Tighten the tool mounting bolts until snug. Do not overtighten.
- 6.2. Tighten the *J 41480* tool-to-rear cover bolts evenly to 12 N·m (106 lb in).
- 6.3. Tighten the rear cover bolts to 25 N·m (18 lb ft).

7. Remove the tools.

8. Measure the rear cover-to-engine block oil pan surface for flatness.
 - 8.1. Place a straight edge onto the engine block and rear cover oil pan sealing surfaces.
Avoid contact with the portion of the gasket that protrudes into the oil pan surface.
 - 8.2. Insert a feeler gage between the rear cover and the straight edge. The cover must be flush with the oil pan or no more than 0.5 mm (0.02 in) below flush.
9. If the rear cover-to-engine block oil pan surface alignment is not within specifications, repeat the cover alignment procedure.
10. If the correct rear cover-to-engine block alignment at the oil pan surface cannot be obtained, replace the rear cover.



63240

Crankshaft Rear Oil Seal Installation

SIE-ID = 644062 LMD = 26-feb-2002

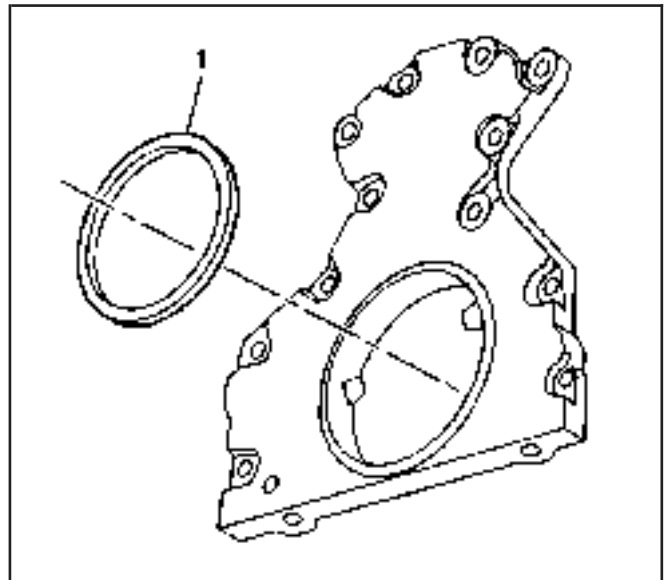
Tools Required

J 41479 Crankshaft Rear Oil Seal Installer

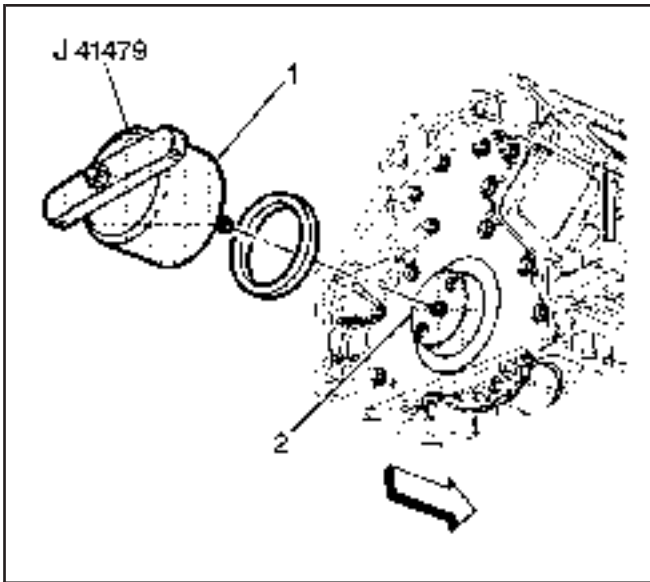
Important:

- The flywheel spacer, if applicable, must be removed prior to oil seal installation.
- Do not lubricate the oil seal inside diameter (ID) or the crankshaft surface.
- Do not use the crankshaft rear oil seal again.

1. Lubricate the outside diameter (OD) of the oil seal (1) with clean engine oil.
DO NOT allow oil or other lubricants to contact the seal surface.
2. Lubricate the rear cover oil seal bore with clean engine oil.
DO NOT allow oil or other lubricants to contact the crankshaft surface.

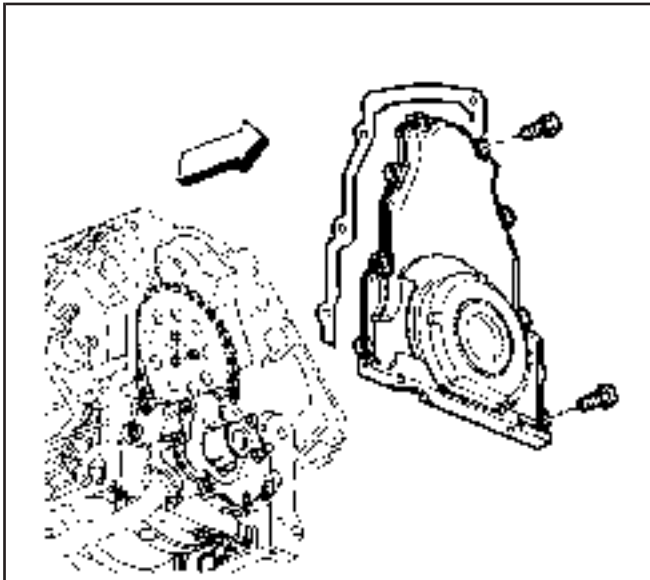


490692



63200

3. Install the *J 41479* cone (2) and bolts onto the rear of the crankshaft.
4. Tighten the bolts until snug. Do not overtighten.
5. Install the rear oil seal onto the tapered cone (2) and push the seal to the rear cover bore.
6. Thread the *J 41479* threaded rod into the tapered cone until the tool (1) contacts the oil seal.
7. Align the oil seal onto the tool (1).
8. Rotate the handle of the tool (1) clockwise until the seal enters the rear cover and bottoms into the cover bore.
9. Remove the tool.



64278

Engine Front Cover Installation

SIE-ID = 73773 LMD = 13-mar-2002

Tools Required

- *J 41480* Front/Rear Cover Alignment – Oil Pan Surface
- *J 41476* Front/Rear Cover Alignment – Crankshaft Oil Seal Area

Important:

- Do not use the crankshaft oil seal or the engine front cover gasket again.
- Do not apply any type sealant to the front cover gasket, unless specified.
- The special tools in this procedure are used to properly align the engine front cover at the oil pan surface and to center the crankshaft front oil seal.
 - All gasket surfaces should be free of oil or other foreign material during assembly.
 - The crankshaft front oil seal **MUST** be centered in relation to the crankshaft.
 - The oil pan sealing surface at the front cover and engine block **MUST** be aligned within specifications.
 - An improperly aligned front cover may cause premature front oil seal wear and/or engine assembly oil leaks.

1. Install the front cover gasket, cover, and bolts onto the engine.
2. Tighten the cover bolts finger tight. Do not overtighten.

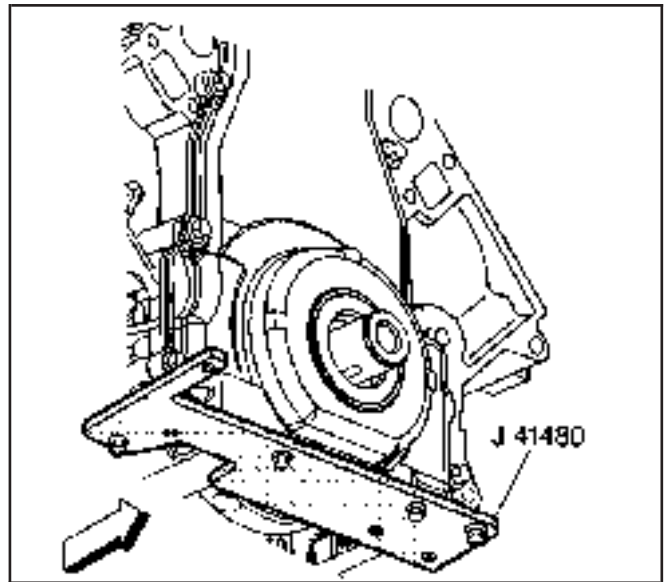
Notice: Refer to *Fastener Notice* in Cautions and Notices.

Important: Start the tool-to-front cover bolts. Do not tighten the bolts at this time.

3. Install the *J 41480*.

Tighten

Tighten the tool-to-engine block bolts to 25 N·m (18 lb ft).



63182

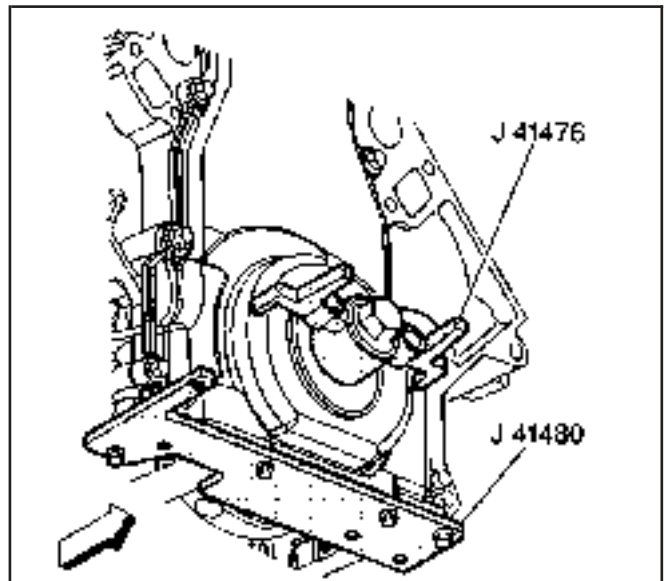
Important: Align the tapered legs of the tool with the machined alignment surfaces on the front cover.

4. Install the *J 41476*.
5. Install the crankshaft balancer bolt.

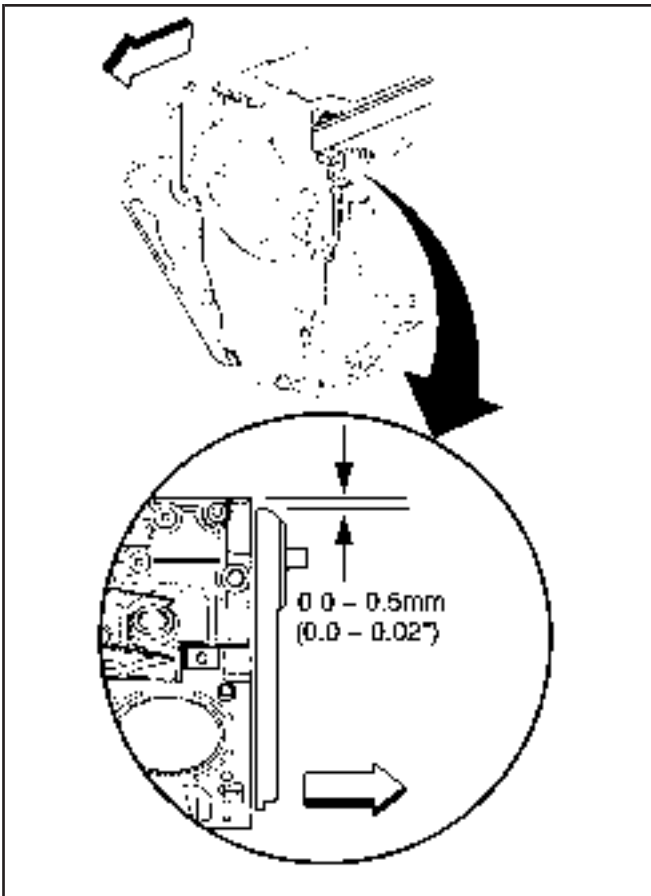
Tighten

- 5.1. Tighten the crankshaft balancer bolt by hand until snug. Do not overtighten.
- 5.2. Tighten the *J 41480*.
- 5.3. Tighten the engine front cover bolts to 25 N·m (18 lb ft).

6. Remove the tools.

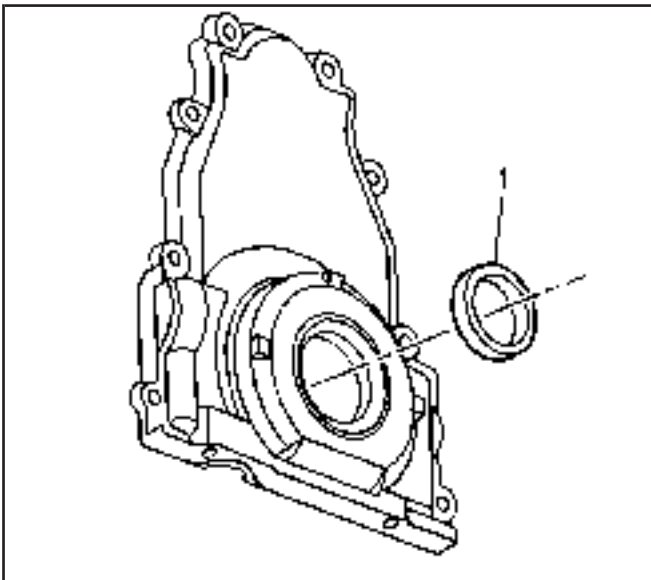


63185



63242

7. Measure the oil pan surface flatness, front cover-to-engine block.
 - 7.1. Place a straight edge across the engine block and front cover oil pan sealing surfaces.
Avoid contact with the portion of the gasket that protrudes into the oil pan surface.
 - 7.2. Insert a feeler gage between the front cover and the straight edge tool. The cover must be flush with the oil pan surface or no more than 0.5 mm (0.02 in) below flush.
8. If the front cover-to-engine block oil pan surface alignment is not within specifications, repeat the cover alignment procedure.
9. If the correct front cover-to-engine block alignment cannot be obtained, replace the front cover.



490689

Crankshaft Front Oil Seal Installation

SIE-ID = 644094 LMD = 01-may-2002

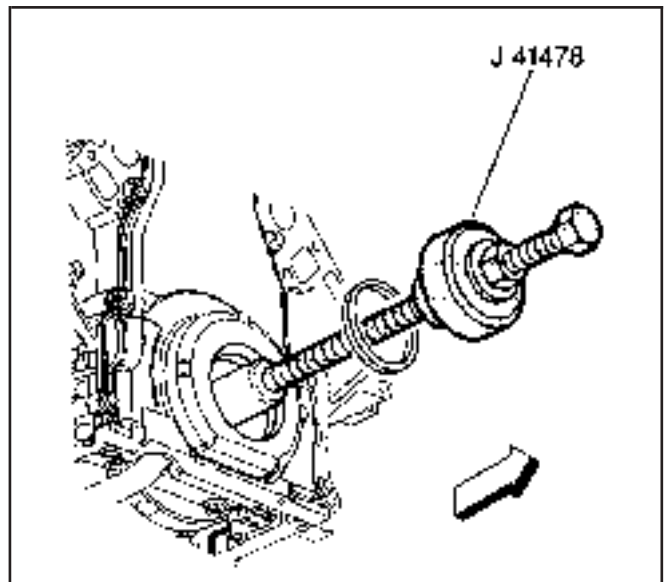
Tools Required

J 41478 Crankshaft Front Oil Seal Installer

Important:

- Do not lubricate the oil seal sealing surface.
 - Do not use the crankshaft front oil seal again.
1. Lubricate the outer edge of the oil seal (1) with clean engine oil.
 2. Lubricate the front cover oil seal bore with clean engine oil.

3. Install the crankshaft front oil seal onto the *J 41478* guide.
4. Install the *J 41478* threaded rod, with nut, washer, guide, and oil seal, into the end of the crankshaft.
5. Use the *J 41478* in order to install the oil seal into the cover bore.
 - 5.1. Use a wrench and hold the hex on the installer bolt.
 - 5.2. Use a second wrench and rotate the installer nut clockwise until the seal bottoms in the cover bore.
 - 5.3. Remove the tool.
 - 5.4. Inspect the oil seal for proper installation. The oil seal should be installed evenly and completely into the front cover bore.



63177

Oil Pan Installation

SIE-ID = 281426 LMD = 26-feb-2002

Important:

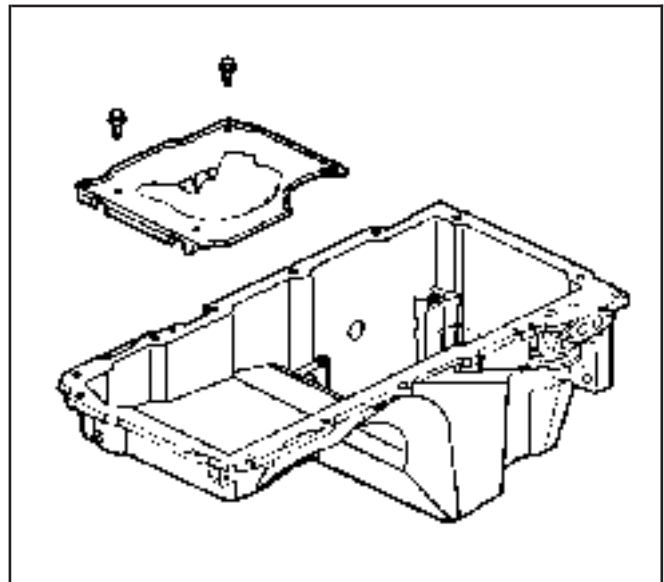
- The alignment of the structural oil pan is critical. The rear bolt hole locations of the oil pan provide mounting points for the transmission housing. To ensure the rigidity of the powertrain and correct transmission alignment, it is important that the rear of the block and the rear of the oil pan are flush or even. The rear of the oil pan must NEVER protrude beyond the engine block and transmission housing plane.
- Do not use the oil pan gasket again.
- It is not necessary to rivet the NEW gasket to the oil pan.
- It is not necessary to remove the oil level sensor prior to oil pan installation.

Notice: Refer to *Fastener Notice* in Cautions and Notices.

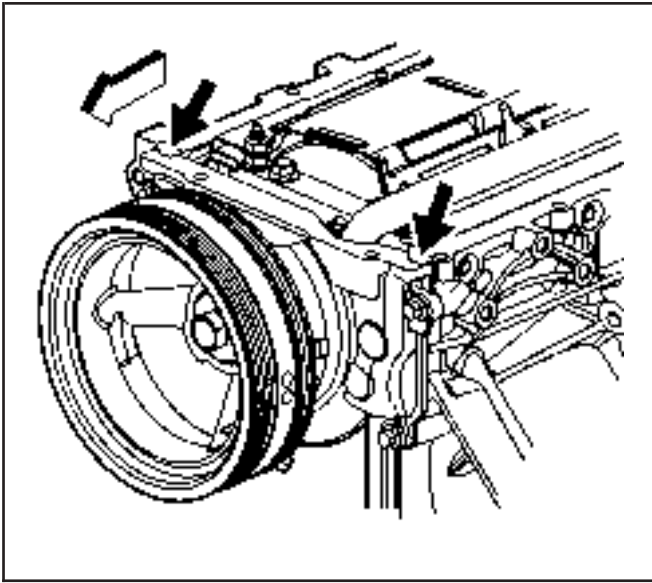
1. Install the oil pan baffle and bolts, if previously removed.

Tighten

Tighten the oil pan baffle bolts to 12 N-m (106 lb in).

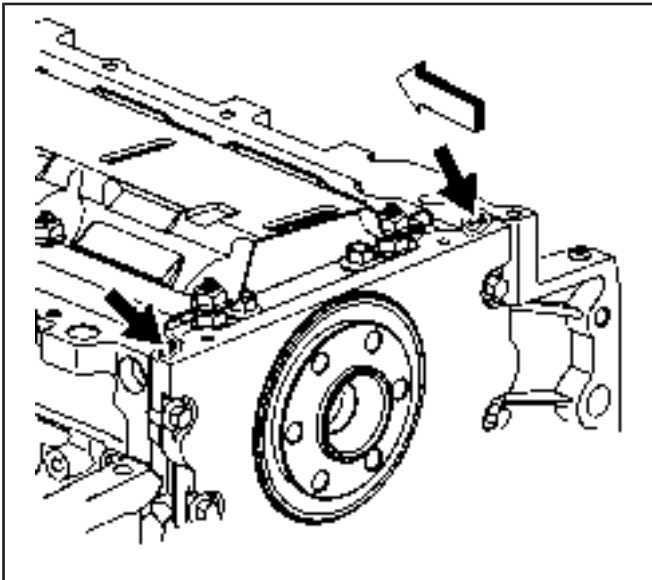


260180



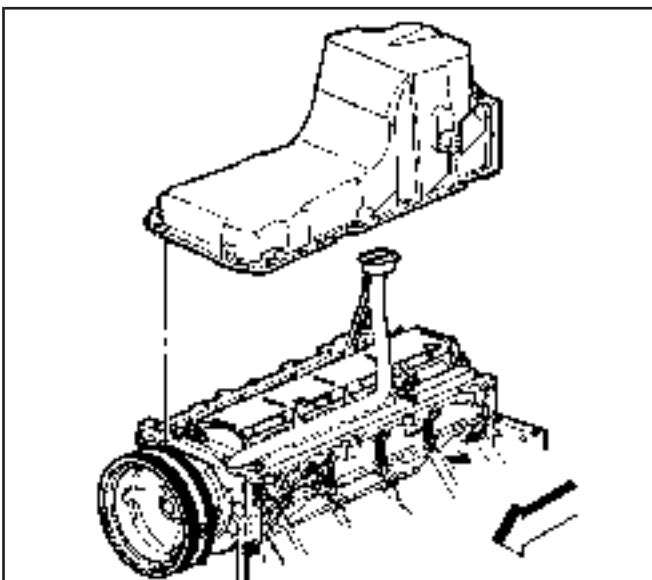
260107

2. Apply a 5 mm (0.2 in) bead of sealant GM P/N 12378190 or equivalent 20 mm (0.8 in) long to the engine block. Apply the sealant directly onto the tabs of the front cover gasket that protrude into the oil pan surface. Refer to *Sealers, Adhesives, and Lubricants*.



63175

3. Apply a 5 mm (0.2 in) bead of sealant GM P/N 12378190 or equivalent 20 mm (0.8 in) long to the engine block. Apply the sealant directly onto the tabs of the rear cover gasket that protrude into the oil pan surface.



260108

Important: Be sure to align the oil gallery passages in the oil pan and engine block properly with the oil pan gasket.

4. Pre-assemble the oil pan gasket to the pan.
 - 4.1. Install the gasket onto the oil pan.
 - 4.2. Install the oil pan bolts to the pan and through the gasket.
5. Install the oil pan, gasket and bolts to the engine block.
6. Tighten bolts finger tight. Do not overtighten.
7. Place a straight edge across the rear of the engine block and the rear of the oil pan at the transmission housing mounting surfaces.

8. Align the oil pan until the rear of engine block and rear of oil pan are flush or even.

Tighten

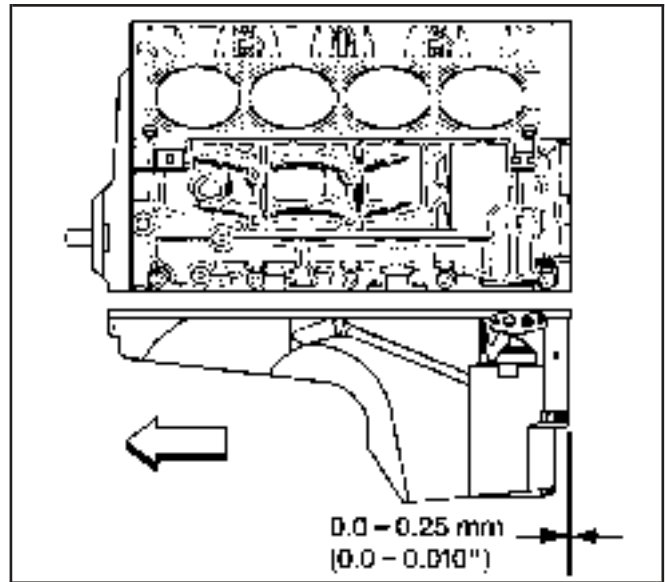
- 8.1. Tighten the oil pan-to-block and oil pan-to-front cover bolts to 25 N·m (18 lb ft).
 - 8.2. Tighten the oil pan-to-rear cover bolts to 12 N·m (106 lb in).
9. Measure the oil pan-to-engine block alignment.
 - 9.1. Place a straight edge across the rear of the engine block and rear of oil pan at the transmission housing mounting surfaces.

Important: The rear of the oil pan must NEVER protrude beyond the engine block and transmission housing mounting surfaces.

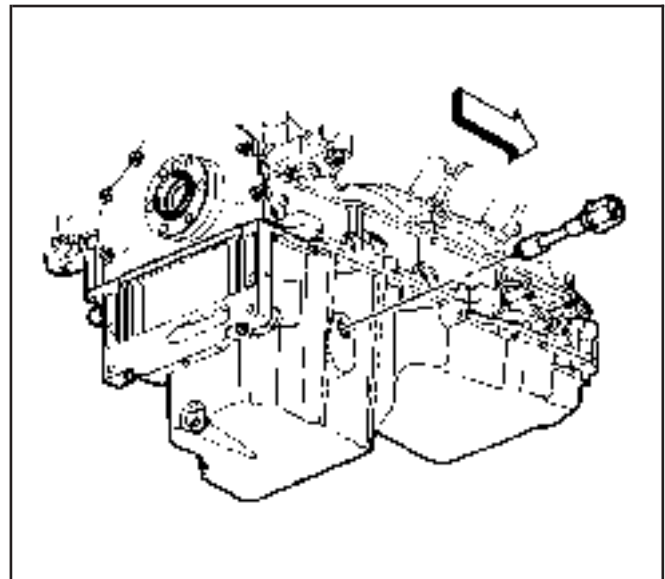
- 9.2. Insert a feeler gage between the straight edge and the oil pan transmission housing mounting surface and check to make sure that there is no more than a 0.25 mm (0.01 in) gap between the pan and straight edge.
 - 9.3. If the oil pan alignment is not within specifications, remove the oil pan and repeat the above procedure.
10. Install the oil level sensor.

Tighten

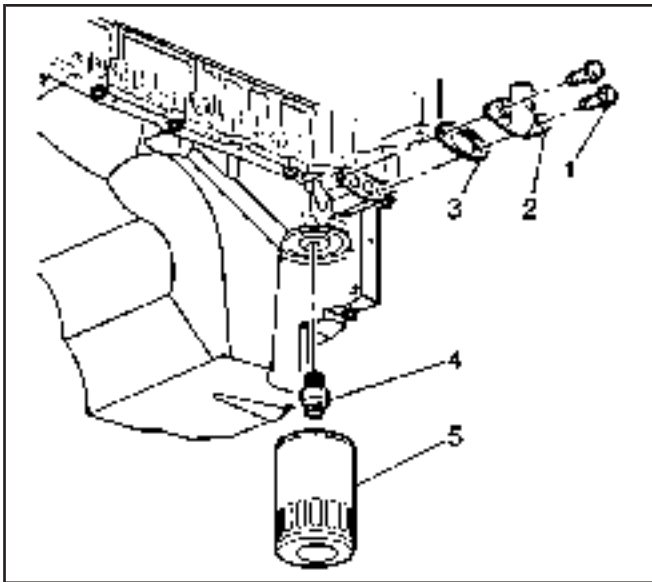
Tighten the oil level sensor to 13 N·m (115 lb in).



260113



260123



260125

Oil Filter, Adapter, Pan Cover Installation

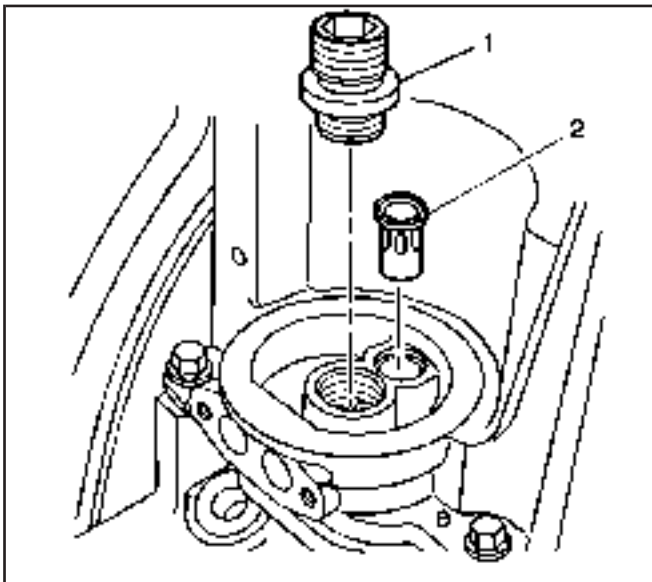
SIE-ID = 281427 LMD = 18-mar-2002

Notice: Refer to *Fastener Notice* in Cautions and Notices.

1. Install the oil pan cover (2), bolts (1), and a NEW oil pan cover gasket (3).

Tighten

Tighten the oil pan cover bolts to 12 N·m (106 lb in).

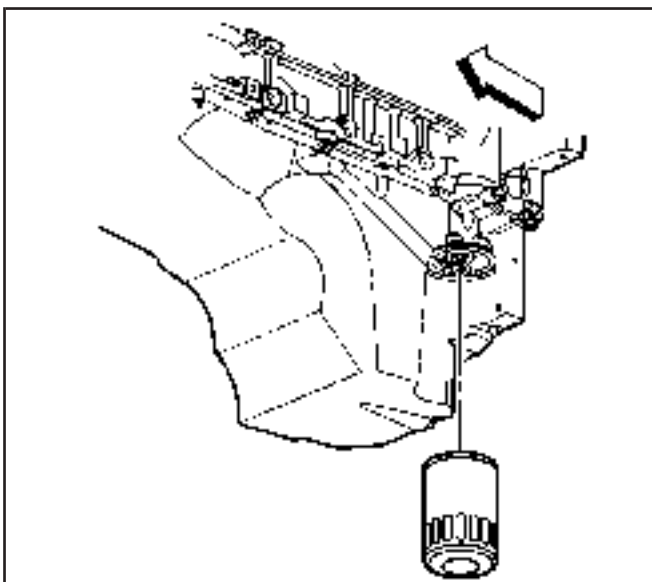


490699

2. Install a new oil filter bypass valve (2) into the oil pan, if required.
3. Install the oil filter fitting (1).

Tighten

Tighten the oil filter fitting to 55 N·m (40 lb ft).



260117

4. Lubricate the oil filter seal with clean engine oil.
5. Install the oil filter.

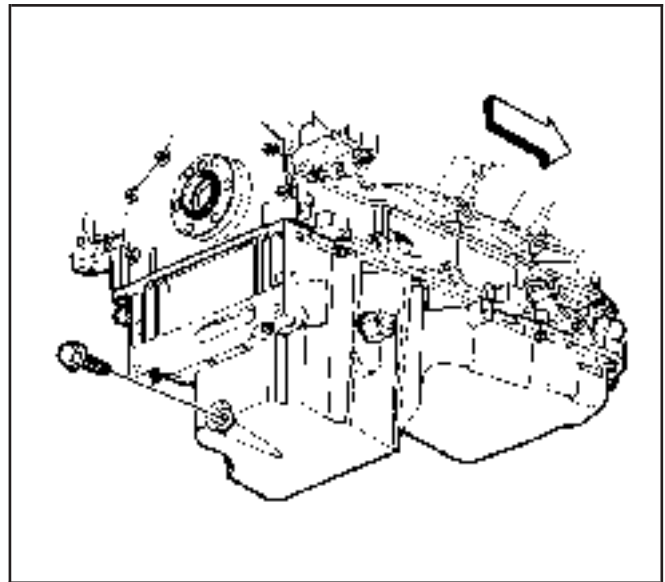
Tighten

Tighten the oil filter to 30 N·m (22 lb ft).

6. Install the oil pan drain plug.

Tighten

Tighten the oil pan drain plug to 25 N·m (18 lb ft).



260111

Valve Lifter Installation

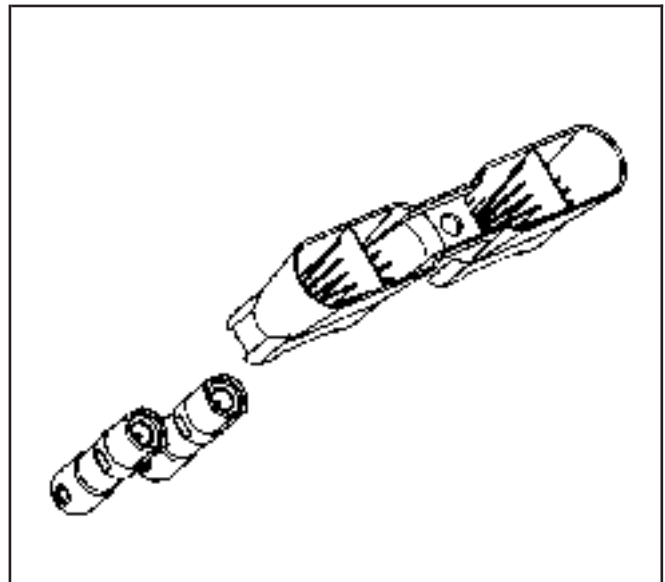
SIE-ID = 73946 LMD = 13-mar-2002

Important: When using the valve lifters again, install the lifters to their original locations.

If camshaft replacement is required, the valve lifters must also be replaced.

1. Lubricate the valve lifters and engine block valve lifter bores with clean engine oil.
2. Insert the valve lifters into the lifter guides.

Align the flat area on the top of the lifter with the flat area in the lifter guide bore. Push the lifter completely into the guide bore.



63233

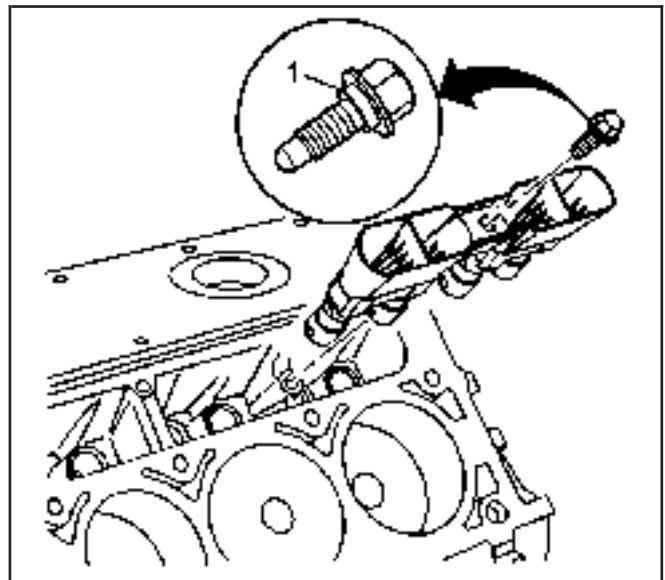
3. Install the valve lifters and guide assembly to the engine block.

Notice: Refer to *Fastener Notice* in Cautions and Notices.

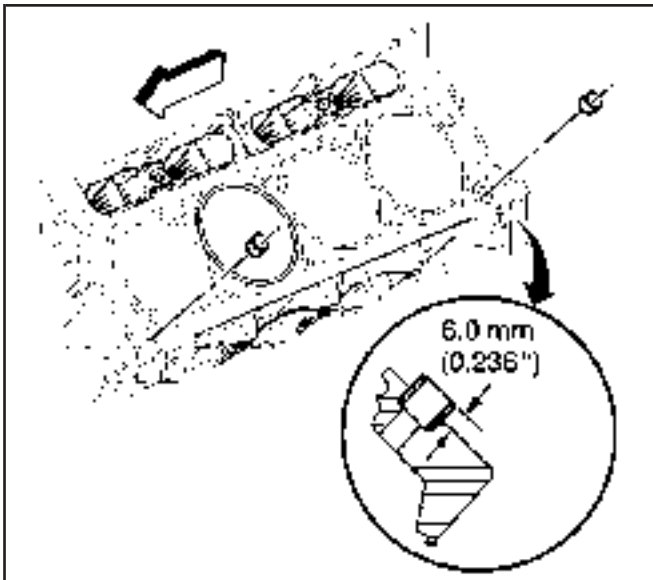
4. Install the valve lifter guide bolt (1).

Tighten

Tighten the valve lifter guide bolt to 12 N·m (106 lb in).



63230



63235

Cylinder Head Installation - Left

SIE-ID = 644096 LMD = 04-apr-2002

Tools Required

- J 36660-A Torque Angle Meter
- J 42385-100 Thread Repair Kit

Caution: Refer to Safety Glasses Caution in Cautions and Notices.

Notice: SIO-ID = 96999 LMD = 13-aug-1996 Clean all dirt, debris, and coolant from the engine block cylinder head bolt holes. Failure to remove all foreign material may result in damaged threads, improperly tightened fasteners or damage to components.

Important:

- Do not use the cylinder head bolts again. Install NEW cylinder head bolts during assembly.
- Do not use any type sealant on the cylinder head gasket, unless specified.
- The cylinder head gaskets must be installed in the proper direction and position.

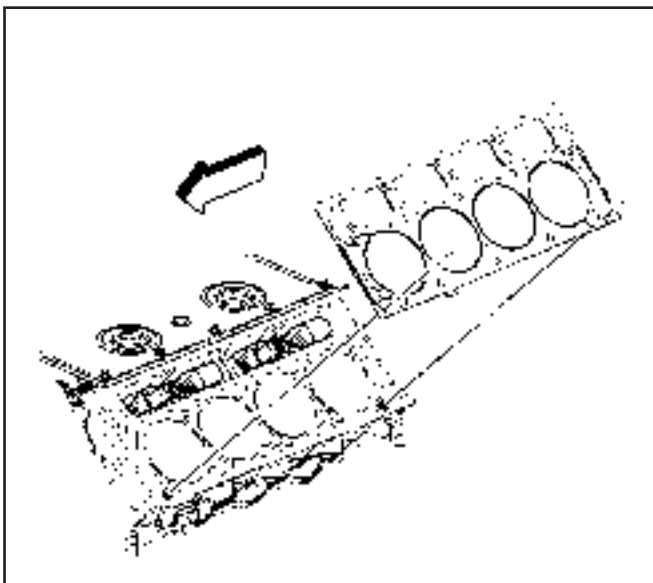
1. Clean the engine block cylinder head bolt holes, if required.

Thread repair tool J 42385-107 may be used to clean the threads of old threadlocking material.

2. Spray cleaner GM P/N 12346139 (Canadian P/N 10953463), GM P/N 12377981 (Canadian P/N 10953463) or equivalent into the hole.
3. Clean the cylinder head bolt holes with compressed air.
4. Check the cylinder head locating pins for proper installation.

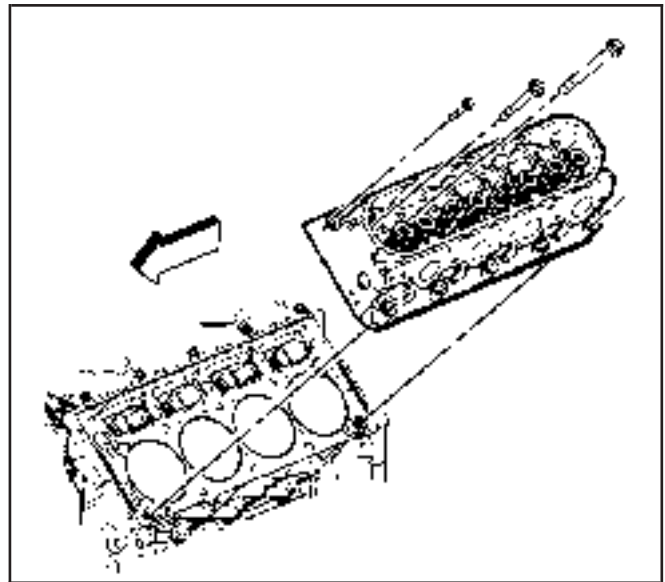
Important: When properly installed, the tab on the left cylinder head gasket will be located left of center or closer to the front of the engine.

5. Install the NEW left cylinder head gasket onto the locating pins.



63169

6. Install the cylinder head onto the locating pins and the gasket.
7. Install the NEW cylinder head bolts.



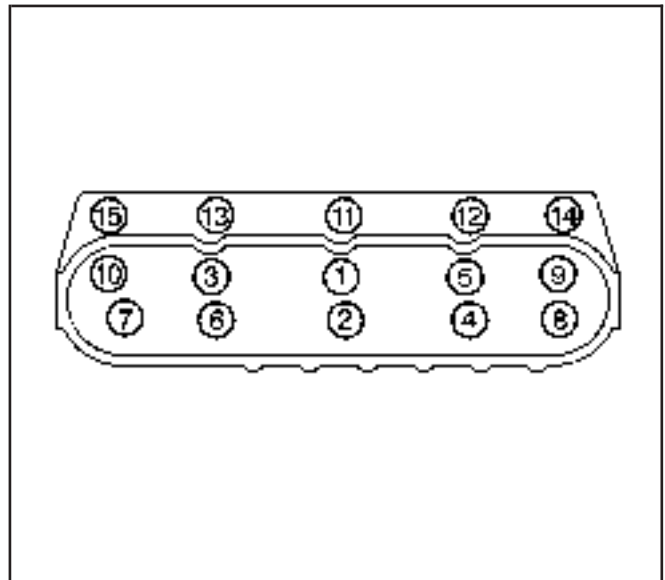
260146

Notice: Refer to *Fastener Notice* in Cautions and Notices.

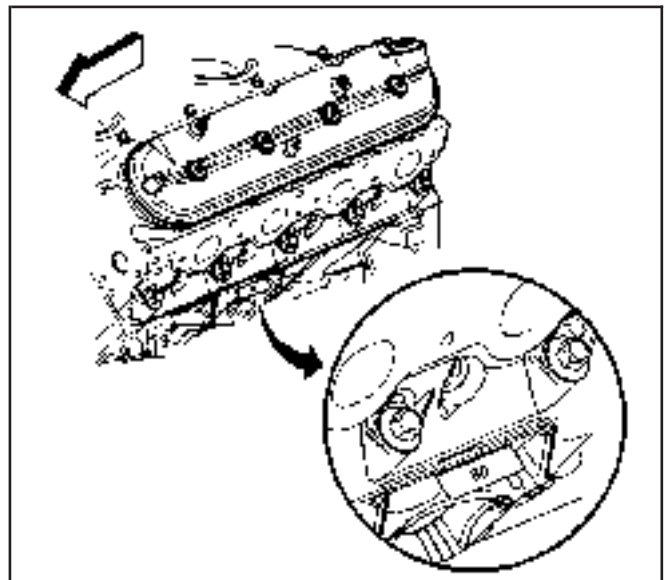
8. Tighten the cylinder head bolts.

Tighten

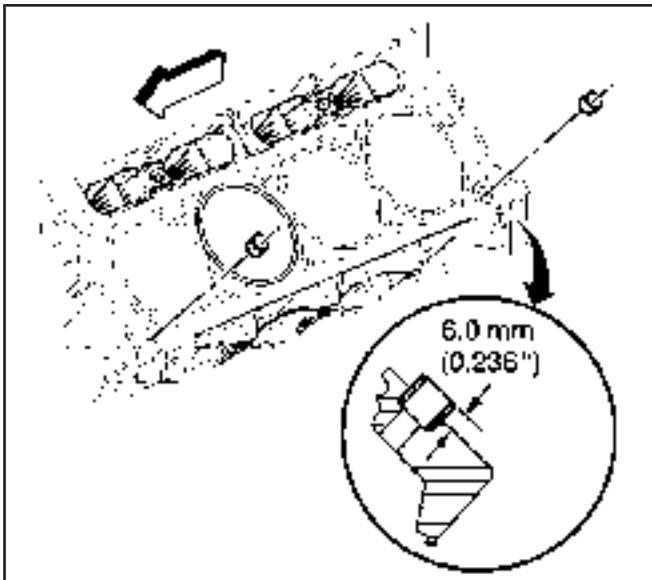
- 8.1. Tighten the M11 cylinder head bolts a first pass in sequence to 30 N-m (22 lb ft).
 - 8.2. Tighten the M11 cylinder head bolts a second pass in sequence to 90 degrees using the *J 36660-A*.
 - 8.3. Tighten the M11 cylinder head bolts (1,2,3,4,5,6,7,8) to 90 degrees and the M11 cylinder head bolts (9 and 10) to 50 degrees a final pass in sequence to using the *J 36660-A*.
 - 8.4. Tighten the M8 cylinder head bolts (11,12,13,14,15) to 30 N-m (22 lb ft). Begin with the center bolt (11) and alternating side-to-side, work outward tightening all of the bolts.
9. The cylinder head gasket displacement can be verified by markings visible on the top side of the left gasket locating tab. Some 4.8/5.3L head gaskets may have 48 or 53 stamped onto the locating tab. Some 6.0L head gaskets may have 60 stamped onto the locating tab.



260150



384697



63235

Cylinder Head Installation - Right

SIE-ID = 644097 LMD = 04-apr-2002

Tools Required

- J 36660-A Torque Angle Meter
- J 42385-100 Thread Repair Kit

Caution: Refer to Safety Glasses Caution in Cautions and Notices.

Notice: SIO-ID = 96999 LMD = 13-aug-1996 Clean all dirt, debris, and coolant from the engine block cylinder head bolt holes. Failure to remove all foreign material may result in damaged threads, improperly tightened fasteners or damage to components.

Important:

- Do not use the cylinder head bolts again. Install NEW cylinder head bolts during assembly.
- Do not use any type sealant on the cylinder head gasket, unless specified.
- The cylinder head gaskets must be installed in the proper direction and position.

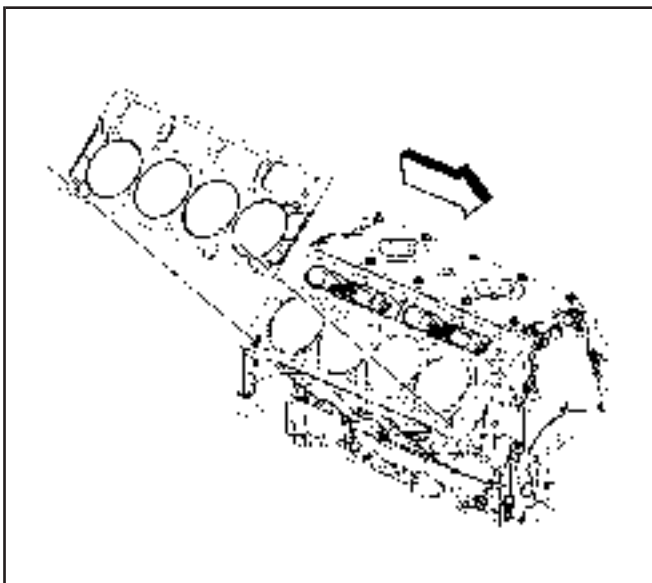
1. Clean the engine block cylinder head bolt holes, if required.

Thread repair tool J 42385-107 may be used to clean the threads of old threadlocking material.

2. Spray cleaner GM P/N 12346139 (Canadian P/N 10953463), GM P/N 12377981 (Canadian P/N 10953463) or equivalent into the hole.
3. Clean the cylinder head bolt holes with compressed air.
4. Check the cylinder head locating pins for proper installation.

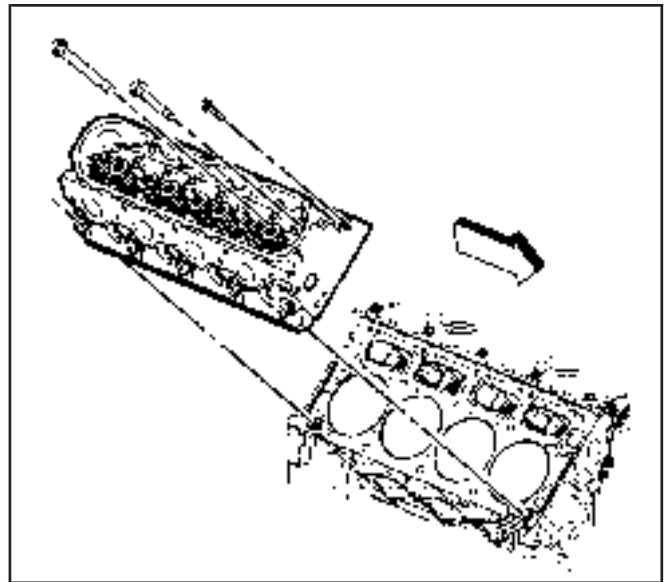
Important: When properly installed, the tab on the right cylinder head gasket will be located right of center or closer to the front of the engine.

5. Install the NEW right cylinder head gasket onto the locating pins.



63170

6. Install the cylinder head onto the locating pins and the gasket.
7. Install the NEW cylinder head bolts.



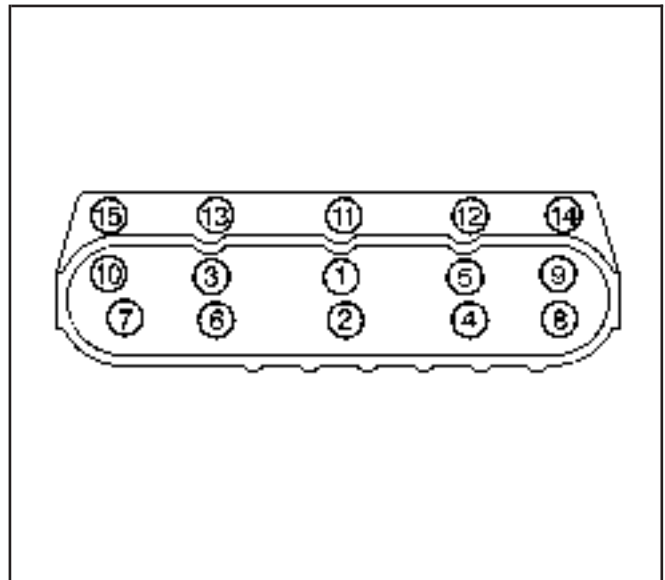
260149

Notice: Refer to *Fastener Notice* in Cautions and Notices.

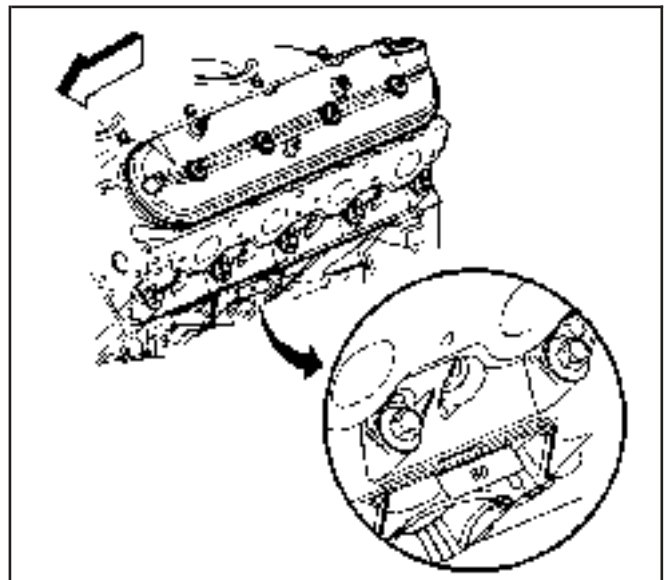
8. Tighten the cylinder head bolts.

Tighten

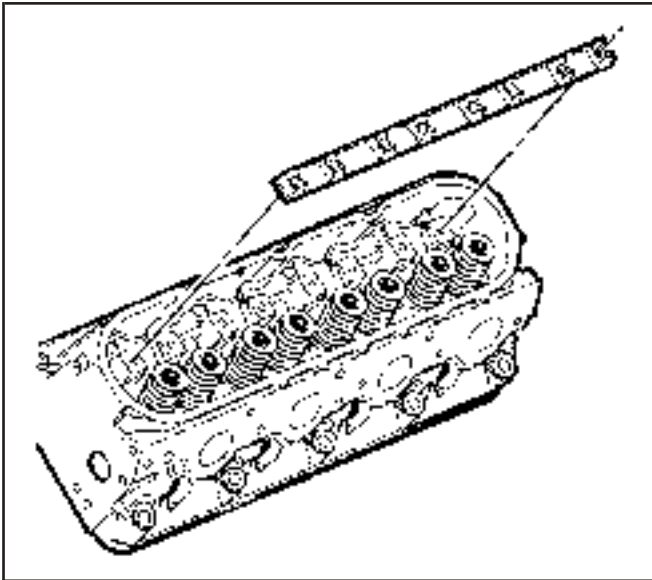
- 8.1. Tighten the M11 cylinder head bolts a first pass in sequence to 30 N-m (22 lb ft).
 - 8.2. Tighten the M11 cylinder head bolts a second pass in sequence to 90 degrees using the *J 36660-A*.
 - 8.3. Tighten the M11 cylinder head bolts (1,2,3,4,5,6,7,8) to 90 degrees and the M11 cylinder head bolts (9 and 10) to 50 degrees a final pass in sequence to using the *J 36660-A*.
 - 8.4. Tighten the M8 cylinder head bolts (11,12,13,14,15) to 30 N-m (22 lb ft). Begin with the center bolt (11) and alternating side-to-side, work outward tightening all of the bolts.
9. The cylinder head gasket displacement can be verified by markings visible on the underside of the right gasket locating tab.
Some 4.8/5.3L head gaskets may have 48 or 53 stamped onto the locating tab.
Some 6.0L head gaskets may have 60 stamped onto the locating tab.



260150



384697



260141

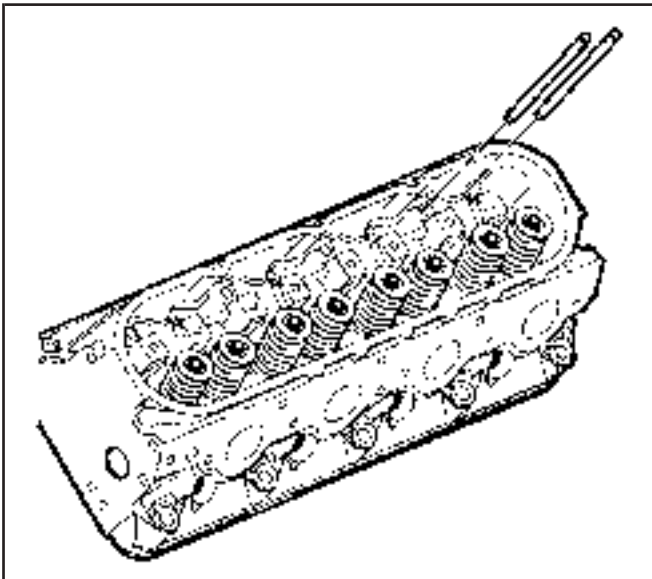
Valve Rocker Arm and Push Rod Installation

SIE-ID = 281433 LMD = 13-mar-2002

Important: When using the valve train components again, always install the components to the original location and position.

Valve lash is net build, no valve adjustment is required.

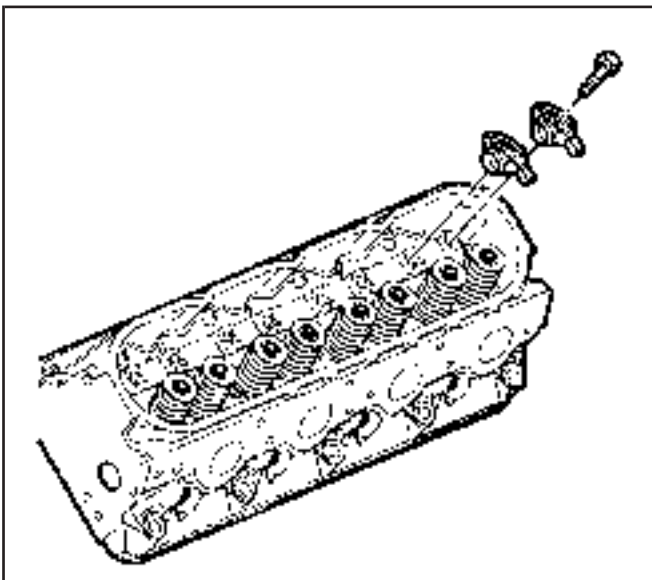
1. Lubricate the valve rocker arms and pushrods with clean engine oil.
2. Lubricate the flange of the valve rocker arm bolts with clean engine oil.
Lubricate the flange or washer surface of the bolt that will contact the valve rocker arm.
3. Install the valve rocker arm pivot support.



260142

Important: Ensure that the pushrods seat properly to the valve lifter sockets.

4. Install the pushrods.



260140

Important: Ensure that the pushrods seat properly to the ends of the rocker arms.

DO NOT tighten the rocker arm bolts at this time.

5. Install the rocker arms and bolts.

6. Rotate the crankshaft until number one piston is at top dead center of compression stroke.
 In this position, cylinder number one rocker arms will be off lobe lift, and the crankshaft sprocket key will be at the 1:30 position. If viewing from the rear of the engine, the additional crankshaft pilot hole, non-threaded, will be in the 10:30 position.
 The engine firing order is 1, 8, 7, 2, 6, 5, 4, 3.
 Cylinders 1, 3, 5 and 7 are left bank.
 Cylinders 2, 4, 6, and 8 are right bank.

Notice: Refer to *Fastener Notice* in Cautions and Notices.

7. With the engine in the number one firing position, tighten the following valve rocker arm bolts:

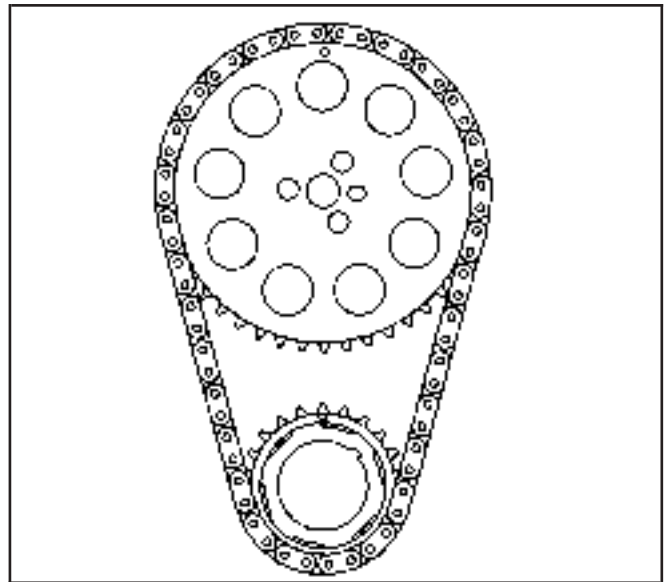
Tighten

- Tighten exhaust valve rocker arm bolts 1, 2, 7, and 8 to 30 N·m (22 lb ft).
- Tighten intake valve rocker arm bolts 1, 3, 4, and 5 to 30 N·m (22 lb ft).

8. Rotate the crankshaft 360 degrees.
9. Tighten the following valve rocker arm bolts:

Tighten

- Tighten exhaust valve rocker arm bolts 3, 4, 5, and 6 to 30 N·m (22 lb ft).
- Tighten intake valve rocker arm bolts 2, 6, 7, and 8 to 30 N·m (22 lb ft).



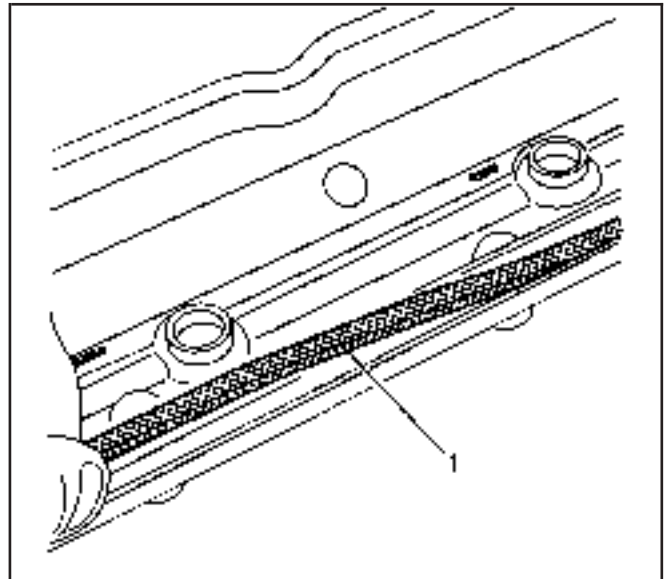
661566

Valve Rocker Arm Cover Installation - Left

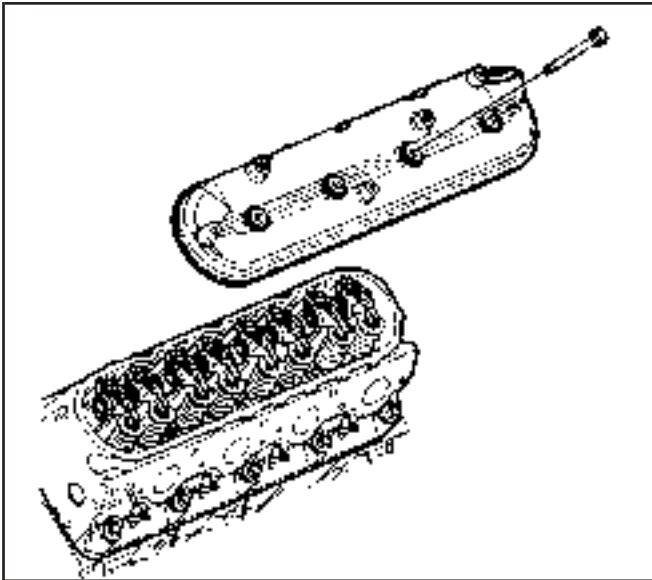
SIE-ID = 644100 LMD = 26-feb-2002

Important:

- All gasket surfaces should be free of oil or other foreign material during assembly.
 - DO NOT use the valve rocker arm cover gasket again.
 - The valve rocker arm cover bolt grommets may be used again.
 - If the vapor vent grommet has been removed from the valve rocker arm cover, install a NEW vapor vent grommet during assembly.
1. Install a NEW cover gasket (1) into the valve rocker arm cover.



490696



260085

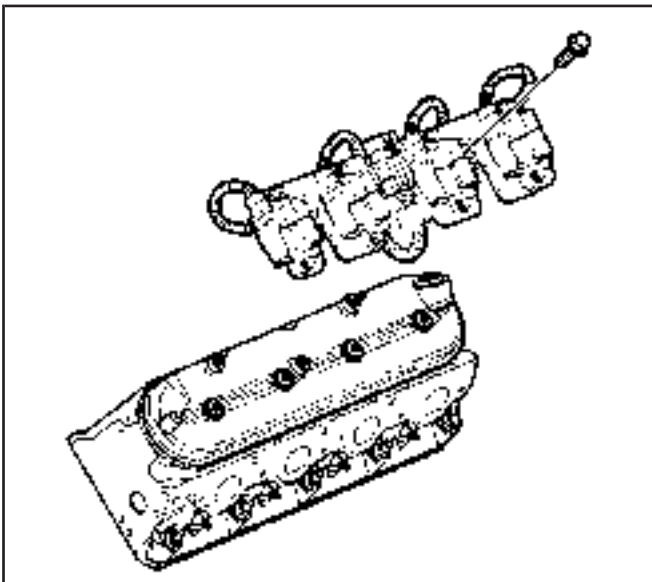
2. Install the valve rocker arm cover onto the cylinder head.

Notice: Refer to *Fastener Notice* in Cautions and Notices.

3. Install the cover bolts with grommets.

Tighten

Tighten the valve rocker arm cover bolts to 12 N·m (106 lb in).



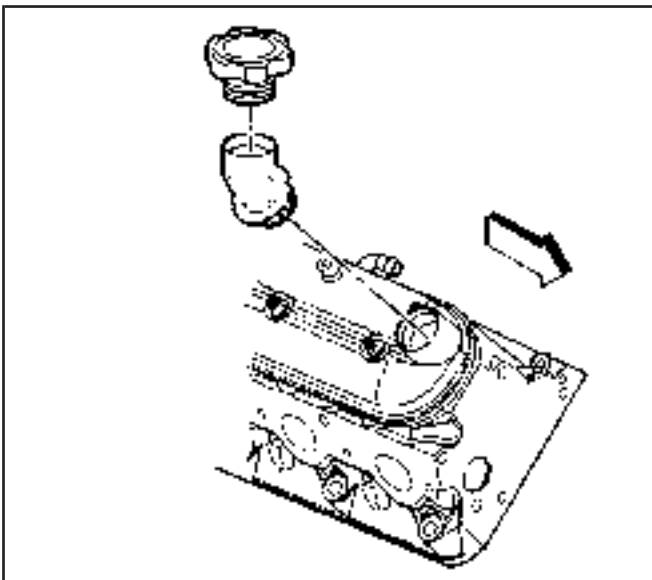
260083

4. Apply threadlock GM P/N 12345382 (Canadian P/N 10953489) or equivalent to the threads of the bracket bolts.

5. Install the ignition coils and bracket assembly and bolts.

Tighten

Tighten the ignition coil and bracket assembly bolts to 12 N·m (106 lb in).



260110

Valve Rocker Arm Cover Installation - Right

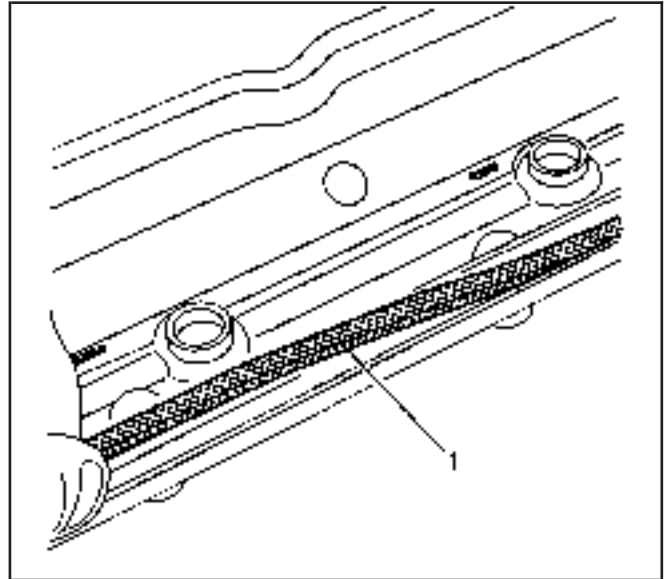
SIE-ID = 644104 LMD = 26-feb-2002

Important:

- All gasket surfaces should be free of oil or other foreign material during assembly.
- Do not use the valve rocker arm cover gasket again.
- Do not remove the ignition coils and bracket from the valve rocker arm cover unless required.
- The valve rocker arm cover bolt grommets may be used again.
- If the oil fill tube has been removed from the valve rocker arm cover, install a NEW oil fill tube during assembly.

1. Lubricate the O-ring seal of the NEW oil fill tube with clean engine oil.

2. Insert the NEW oil fill tube into the rocker arm cover and rotate the tube clockwise until locked in the proper position.
3. Install the oil fill cap into the tube and rotate clockwise until locked in the proper position.
4. Install a NEW cover gasket (1) into the valve rocker arm cover.



490696

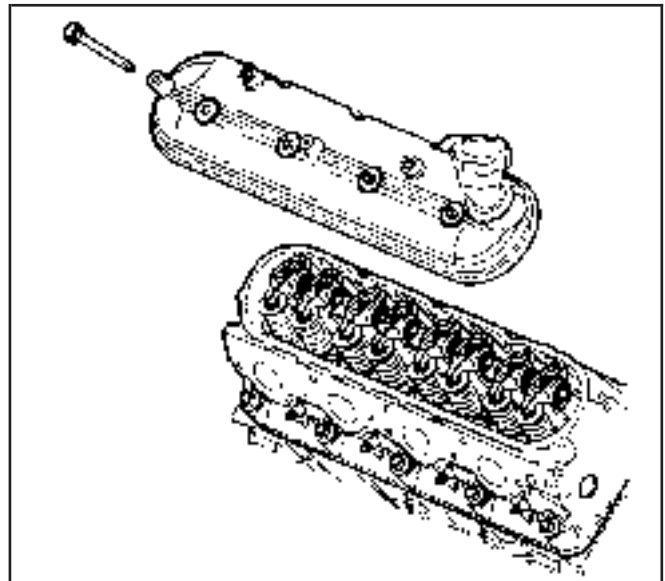
5. Install the valve rocker arm cover onto the cylinder head.

Notice: Refer to *Fastener Notice* in Cautions and Notices.

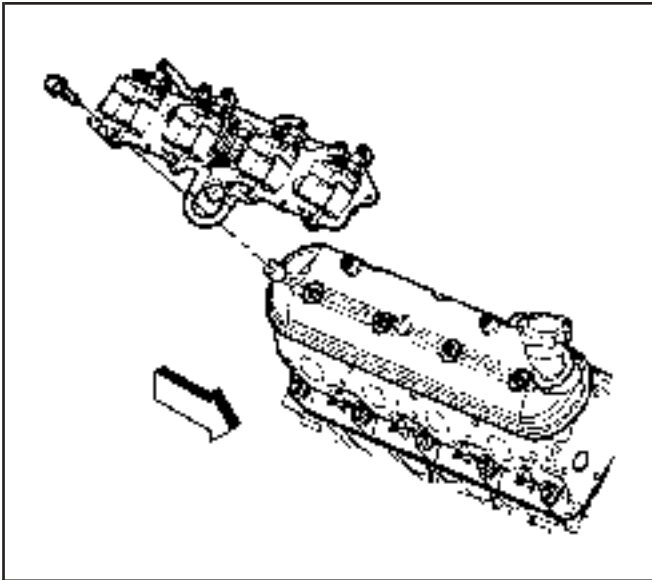
6. Install the cover bolts with grommets.

Tighten

Tighten the valve rocker arm cover bolts to 12 N·m (106 lb in).



260084

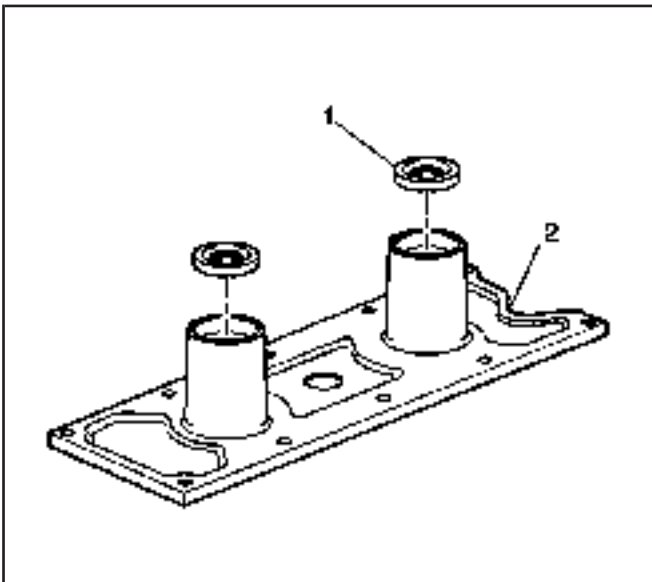


260090

7. Apply threadlock GM P/N 12345382 (Canadian P/N 10953489) or equivalent to the threads of the bracket bolts.
8. Install the ignition coil and bracket assembly and bolts.

Tighten

Tighten the ignition coil and bracket assembly studs to 12 N·m (106 lb in).



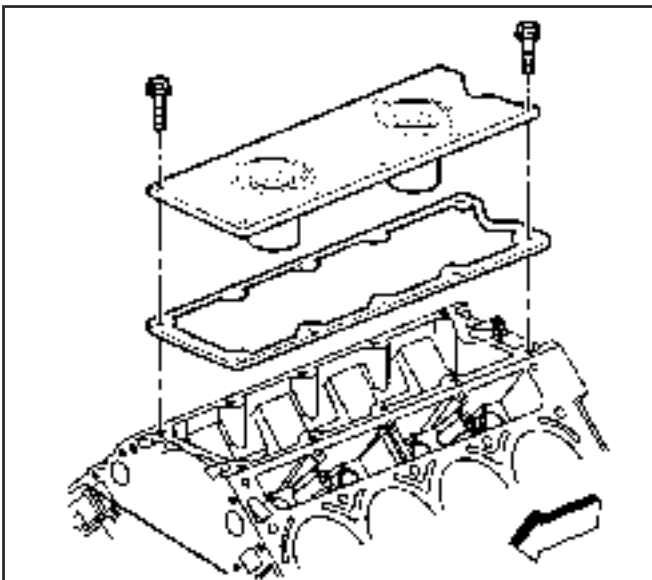
490851

Engine Valley Cover Installation

SIE-ID = 322942 LMD = 01-oct-1998

Important: All gasket surfaces should be free of oil or other foreign material during assembly.

1. Install NEW knock sensor oil seals (1) into the valley cover (2).
Lubricate the seal surfaces with clean engine oil.



65048

2. Install the valley cover and NEW gasket.

Notice: Refer to *Fastener Notice* in Cautions and Notices.

3. Install the valley cover bolts.

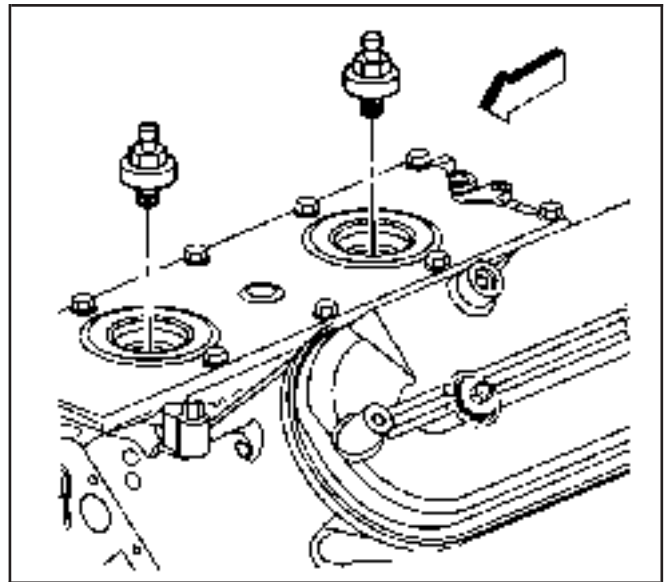
Tighten

Tighten the valley cover bolts to 25 N·m (18 lb ft).

4. Install the knock sensors.

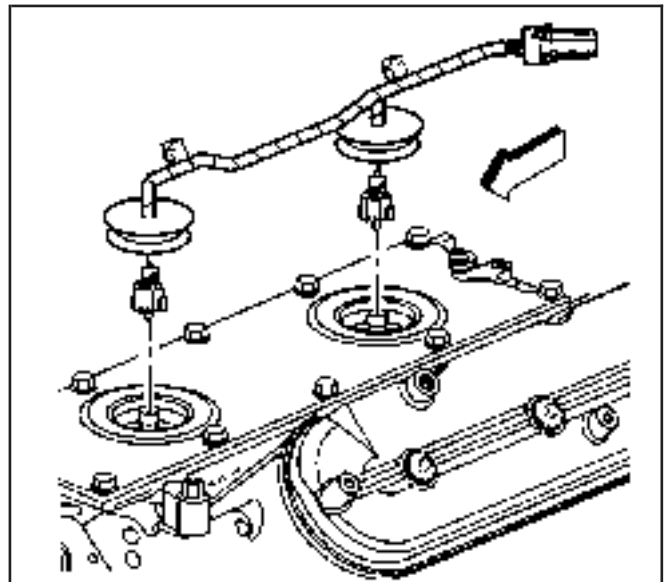
Tighten

Tighten the knock sensors to 20 N·m (15 lb ft).



309864

5. Install the knock sensor wire harness.



309859

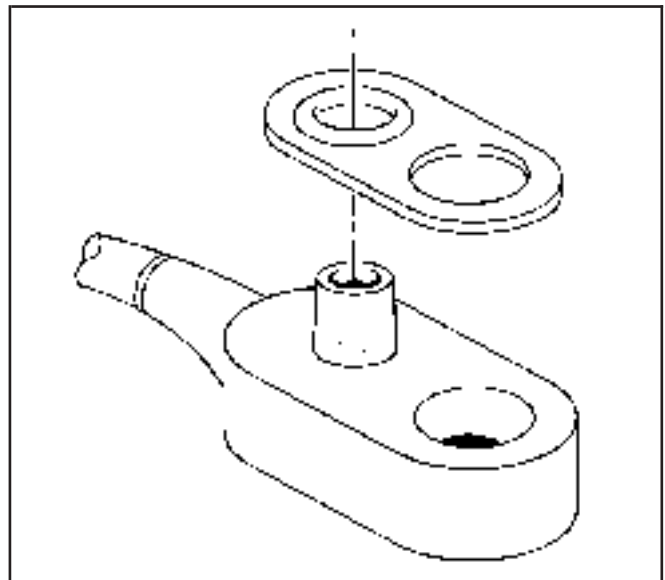
Coolant Air Bleed Pipe Installation

SIE-ID = 741685 LMD = 29-mar-2001

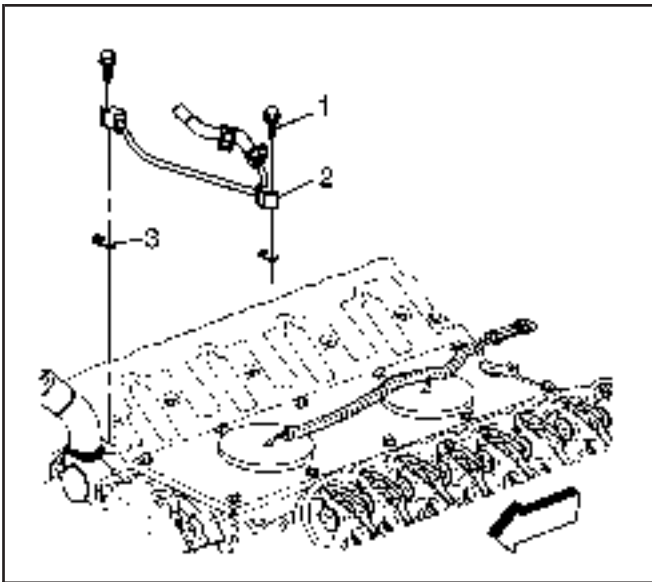
Important: Install the pipe gaskets properly onto the pipe and covers.

Position the gasket O-ring seal onto the nipple portion of the pipe.

1. Install the gaskets onto the engine coolant air bleed pipe and covers.



64262



741555

2. Install the pipe (2) and gaskets (3) onto the cylinder heads.

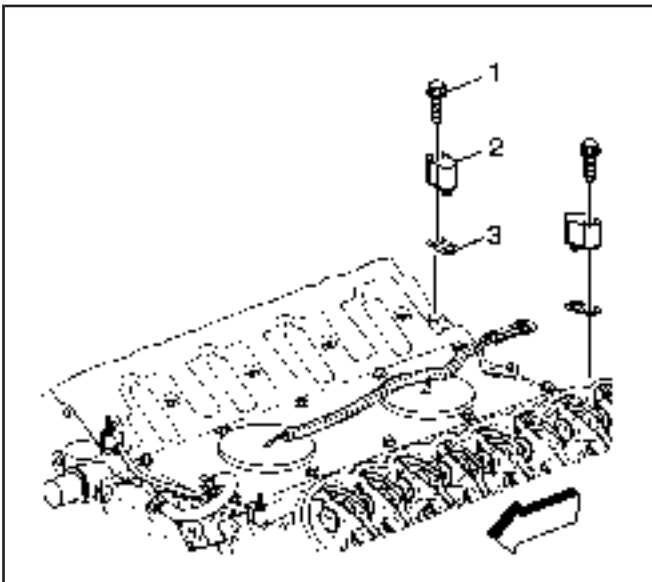
Notice: Refer to *Fastener Notice* in Cautions and Notices.

3. Install the pipe bolts (1).

Install the two pipe studs to the front of the engine.

Tighten

Tighten the pipe bolts to 12 N·m (106 lb in).

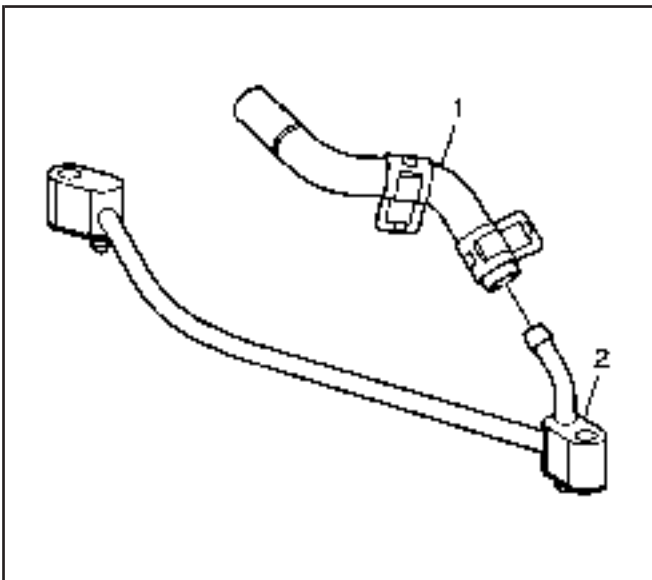


639609

4. Install the covers (2), gaskets (3), and bolts (1) onto the rear of the engine.

Tighten

Tighten the cover bolts to 12 N·m (106 lb in).



790766

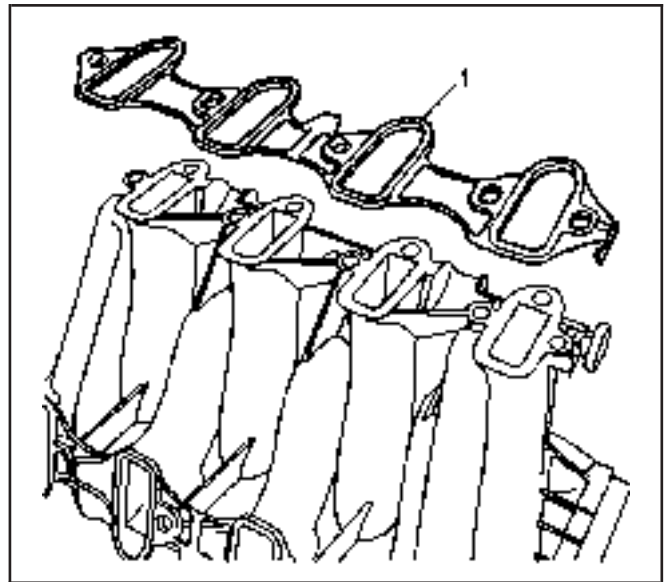
5. Install the hose and clamp (1) onto the pipe (2).

Intake Manifold Installation

SIE-ID = 863436 LMD = 25-mar-2002

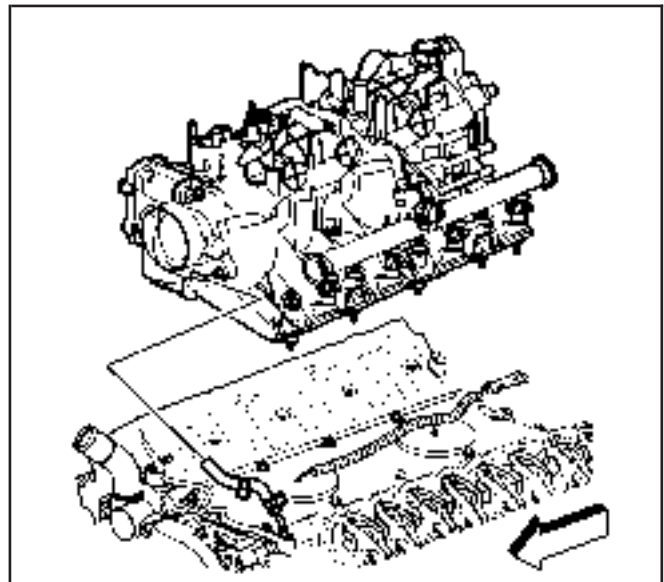
Important:

- The intake manifold, throttle body, fuel injection rail and fuel injectors may be removed as an assembly. If not servicing the individual components, install the intake manifold as a complete assembly.
 - DO NOT use the old intake manifold gaskets again. Install NEW intake manifold-to-cylinder head gaskets.
1. Install NEW intake manifold-to-cylinder head gaskets (1).



492770

2. Install the intake manifold.
3. Apply a 5 mm (0.20 in) band of threadlock GM P/N 12345382 (Canadian P/N 10953489) or equivalent to the threads of the intake manifold bolts. Refer to *Sealers, Adhesives, and Lubricants*.



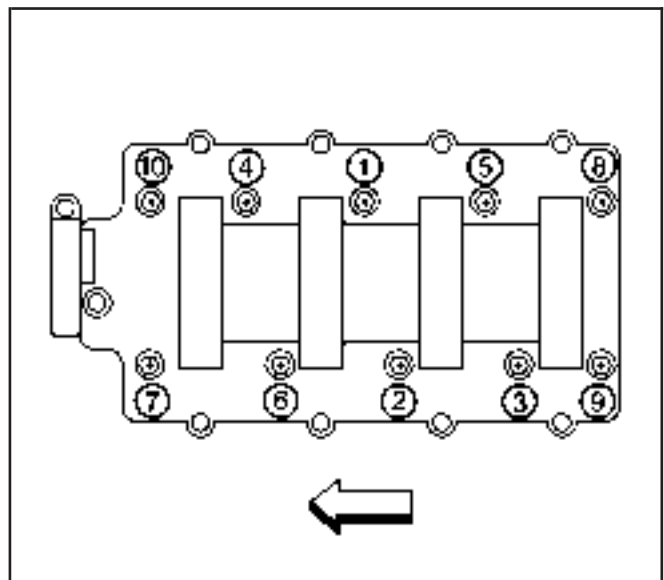
863069

Notice: Refer to *Fastener Notice* in Cautions and Notices.

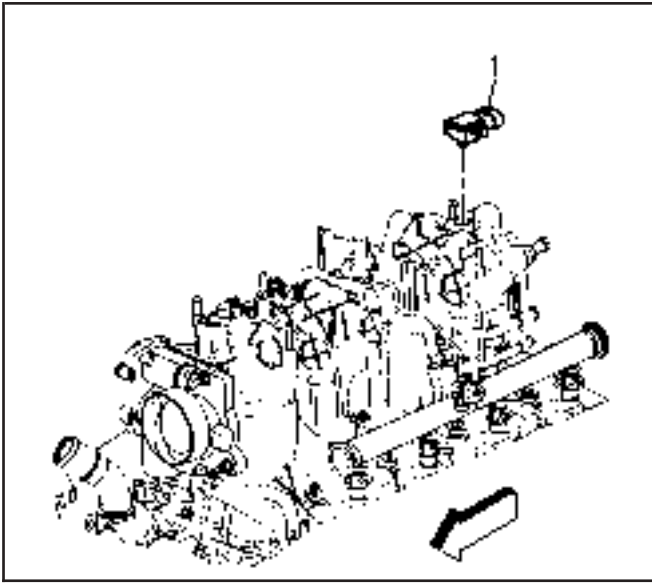
4. Install the intake manifold bolts.

Tighten

- 4.1. Tighten intake manifold bolts first pass in sequence to 5 N·m (44 lb in).
- 4.2. Tighten intake manifold bolts final pass in sequence to 10 N·m (89 lb in).

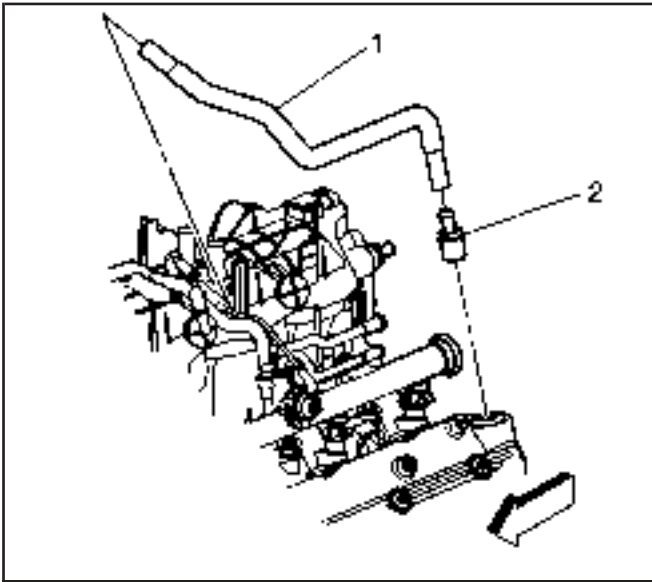


63222



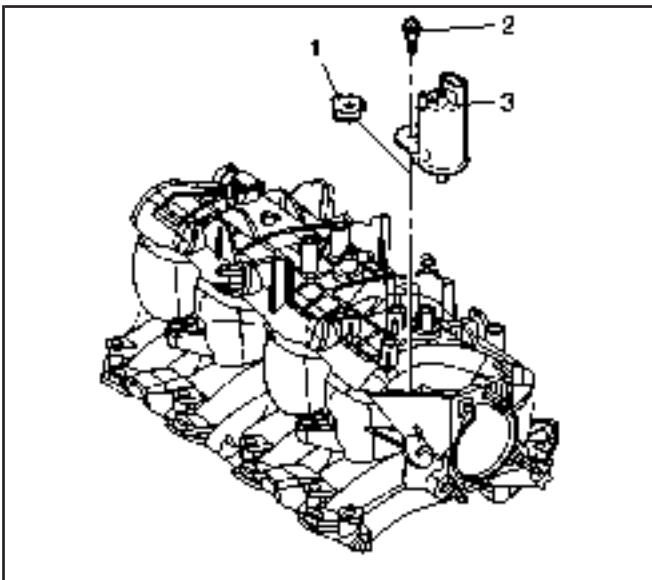
863068

5. Install the manifold absolute pressure (MAP) sensor (1), if previously removed.
The electrical connector end of the sensor should be facing the front of the engine.



869526

6. Install the positive crankcase ventilation (PCV) valve (2) and hose (1).
7. Install the engine coolant air bleed hose and clamp onto the throttle body.



869529

8. Install the evaporative emission (EVAP) purge solenoid (3), bolt (2), and isolator (1).

Tighten

Tighten the solenoid bolt to 10 N·m (89 lb in).

Fuel Rail and Injectors Installation

SIE-ID = 281438 LMD = 26-feb-2002

Caution: Refer to *Fuel Rail Stop Bracket Installation Caution in Cautions and Notices.*

Important: DO NOT use the fuel injector O-ring seals again. Install NEW fuel injector O-ring seals during assembly.

1. Lubricate the NEW fuel injector O-ring seals with clean engine oil.
2. Install the O-ring seals onto the fuel injectors.
3. Install a new O-ring seal to the right side of the crossover tube.
4. Assemble the crossover tube and bolt to the right fuel rail.
5. Install the fuel rail, with fuel injectors, into the intake manifold.

Press evenly on both sides of the fuel rail until all of the injectors are seated in their bores.

6. Apply a 5 mm (0.2 in) band of threadlock GM P/N 12345382 (Canadian P/N 10953489) or equivalent to the threads of the fuel rail bolts. Refer to *Sealers, Adhesives, and Lubricants.*

Notice: Refer to *Fastener Notice in Cautions and Notices.*

7. Install the fuel rail bolts.

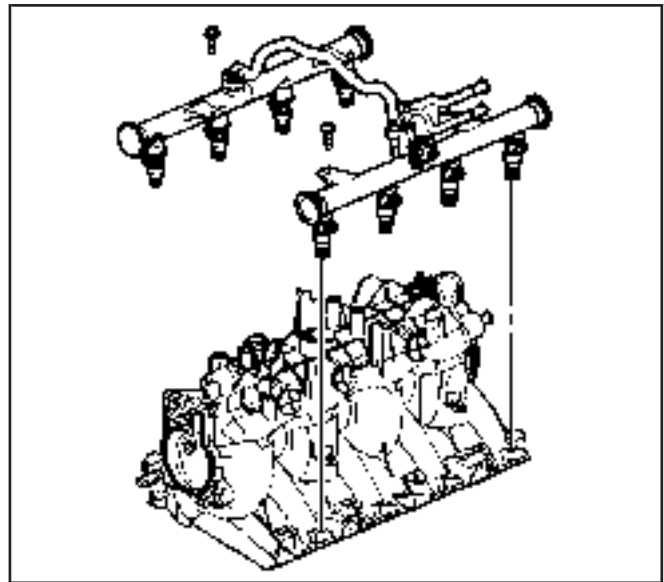
Tighten

- 7.1. Tighten the fuel rail bolts to 10 N·m (89 lb in).
- 7.2. Tighten the crossover tube right side retaining bolt to 3.8 N·m (34 lb in).

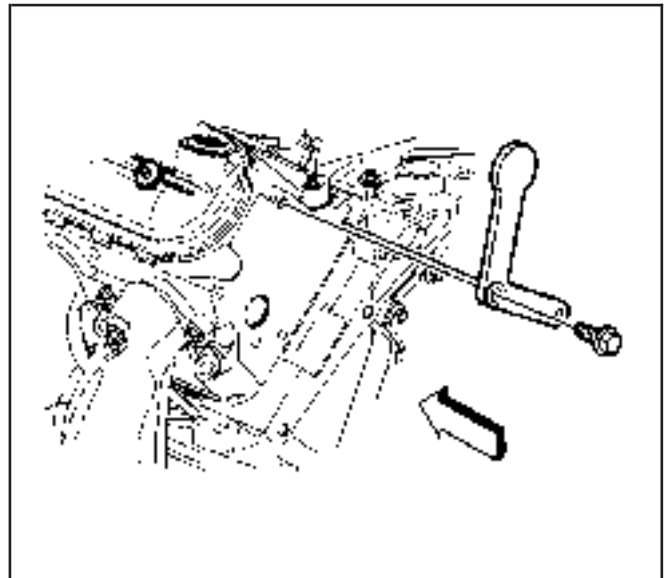
8. Install the fuel rail stop bracket and bolt.

Tighten

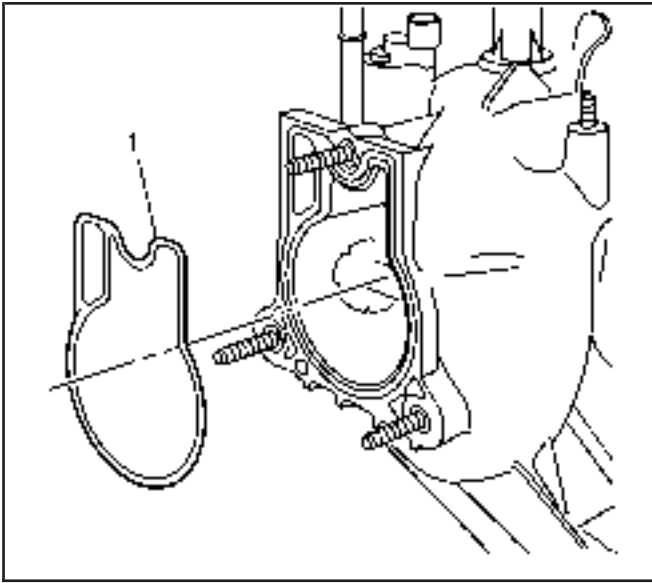
Tighten the fuel rail stop bracket bolt to 50 N·m (37 lb ft).



260176



260098



492774

Throttle Body Installation

SIE-ID = 866463 LMD = 10-jun-2002

Notice: Refer to *Fastener Notice* in Cautions and Notices.

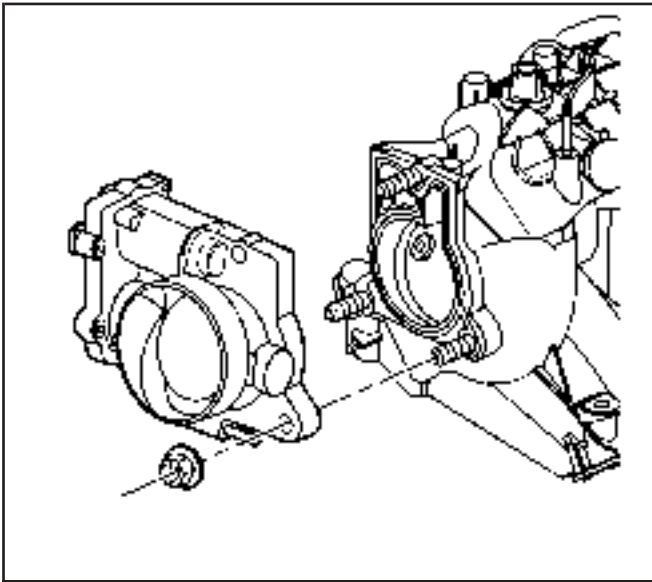
1. Install the throttle body studs, if required.

Tighten

Tighten the throttle body studs to 6 N·m (53 lb in).

Important: DO NOT use the throttle body gasket again. Install a NEW gasket during assembly.

2. Install the throttle body gasket (1) to the intake manifold.



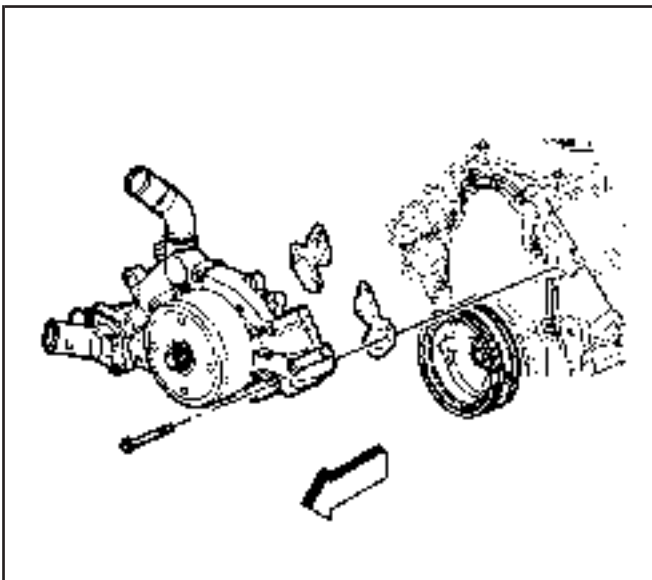
825837

3. Install the throttle body and nuts.

Tighten

Tighten the throttle body nuts to 10 N·m (89 lb in).

4. Install the engine coolant air bleed hose and clamp to the throttle body.



260121

Water Pump Installation

SIE-ID = 667807 LMD = 25-jan-2000

Notice: SIO-ID = 73446 LMD = 26-jul-2001 DO NOT use cooling system seal tabs, or similar compounds, unless otherwise instructed. The use of cooling system seal tabs, or similar compounds, may restrict coolant flow through the passages of the cooling system or the engine components. Restricted coolant flow may cause engine overheating and/or damage to the cooling system or the engine components/assembly.

Important: All gasket surfaces to be free of oil or other foreign material during assembly.

1. Install the water pump and NEW gaskets.

Notice: Refer to *Fastener Notice* in Cautions and Notices.

2. Install the water pump bolts.

Tighten

- 2.1. Tighten the water pump bolts first pass to 15 N·m (11 lb ft).
- 2.2. Tighten the water pump bolts final pass to 30 N·m (22 lb ft).

Exhaust Manifold Installation - Left

SIE-ID = 741689 LMD = 26-feb-2002

Important:

- Tighten the exhaust manifold bolts as specified in the service procedure. Improperly installed and/or leaking exhaust manifold gaskets may affect vehicle emissions and/or On-Board Diagnostic (OBD) II system performance.
- The cylinder head exhaust manifold bolt hole threads must be clean and free of debris or threadlocking material.

Important: Do not apply sealant to the first three threads of the bolt.

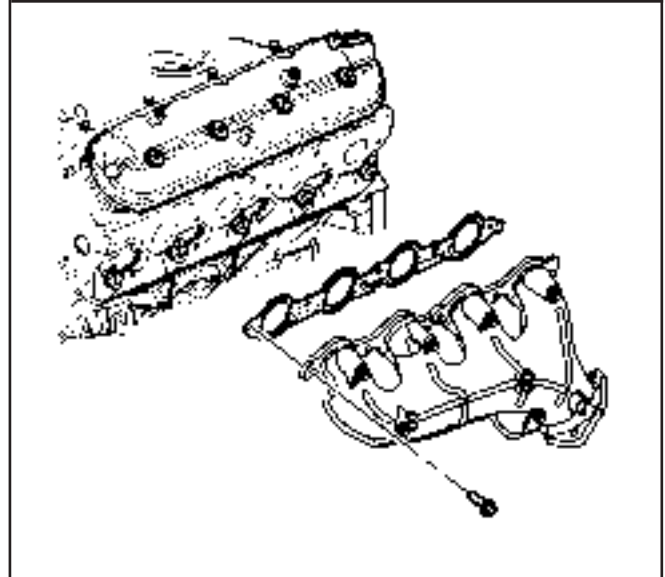
1. Apply a 5 mm (0.2 in) wide band of threadlock GM P/N 12345493 (Canadian P/N 10953488) or equivalent to the threads of the exhaust manifold bolts. Refer to *Sealers, Adhesives, and Lubricants*.
2. Install the exhaust manifold and NEW exhaust manifold gasket.

Notice: Refer to *Fastener Notice* in Cautions and Notices.

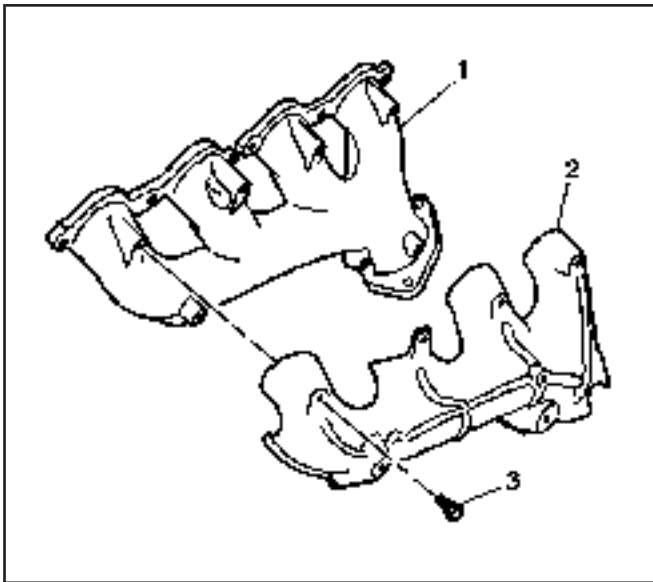
3. Install the exhaust manifold bolts.

Tighten

- 3.1. Tighten the exhaust manifold bolts a first pass to 15 N·m (11 lb ft). Tighten the exhaust manifold bolts beginning with the center two bolts. Alternate from side-to-side, and work toward the outside bolts.
- 3.2. Tighten the exhaust manifold bolts a final pass to 25 N·m (18 lb ft). Tighten the exhaust manifold bolts beginning with the center two bolts. Alternate from side-to-side, and work toward the outside bolts.
4. Using a flat punch, bend over the exposed edge of the exhaust manifold gasket at the rear of the left cylinder head.



741552

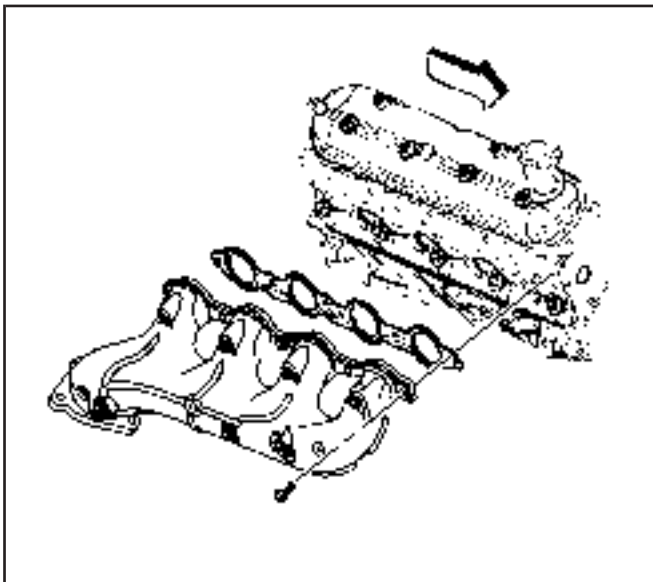


492766

5. Install the heat shield (2) and bolts (3).

Tighten

Tighten the heat shield bolts to 9 N·m (80 lb in).



823317

Exhaust Manifold Installation - Right

SIE-ID = 823841 LMD = 26-feb-2002

Important:

- Tighten the exhaust manifold bolts as specified in the service procedure. Improperly installed and/or leaking exhaust manifold gaskets may affect vehicle emissions and/or On-Board Diagnostic (OBD) II system performance.
- The cylinder head exhaust manifold bolt hole threads must be clean and free of debris or threadlocking material.

1. Apply a 5 mm (0.2 in) wide band of threadlock GM P/N 12345493 (Canadian P/N 10953488) or equivalent to the threads of the exhaust manifold bolts. Refer to *Sealers, Adhesives, and Lubricants*.
2. Install the exhaust manifold gasket and exhaust manifold.

Notice: Refer to *Fastener Notice* in Cautions and Notices.

3. Install the exhaust manifold bolts.

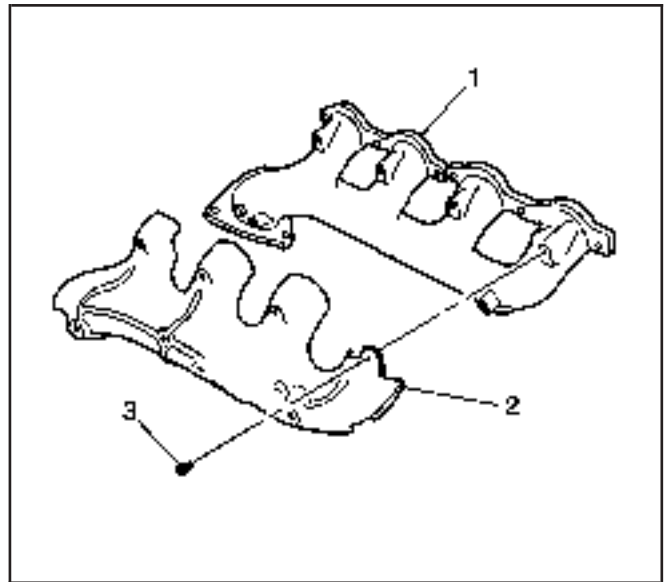
Tighten

- 3.1. Tighten the exhaust manifold bolts first pass to 15 N·m (11 lb ft). Tighten the exhaust manifold bolts beginning with the center two bolts. Alternate from side-to-side, and work toward the outside bolts.
- 3.2. Tighten the exhaust manifold bolts final pass to 25 N·m (18 lb ft). Tighten the exhaust manifold bolts beginning with the center two bolts. Alternate from side-to-side, and work toward the outside bolts.
4. Using a flat punch, bend over the exposed edge of the exhaust manifold gasket at the front of the right cylinder head.

5. Install the heat shield (2) and bolts (3).

Tighten

Tighten the heat shield bolts to 9 N·m (80 lb in).



823320

Oil Level Indicator and Tube Installation

SIE-ID = 281445 LMD = 24-jul-1998

1. Inspect the O-ring seal for cuts or damage. If the oil level indicator tube O-ring seal is not cut or damaged, it may be reused.
2. Lubricate the O-ring seal with clean engine oil.
3. Install the O-ring seal onto the oil level indicator tube.
4. Install the oil level indicator tube into the engine block and rotate into proper position.

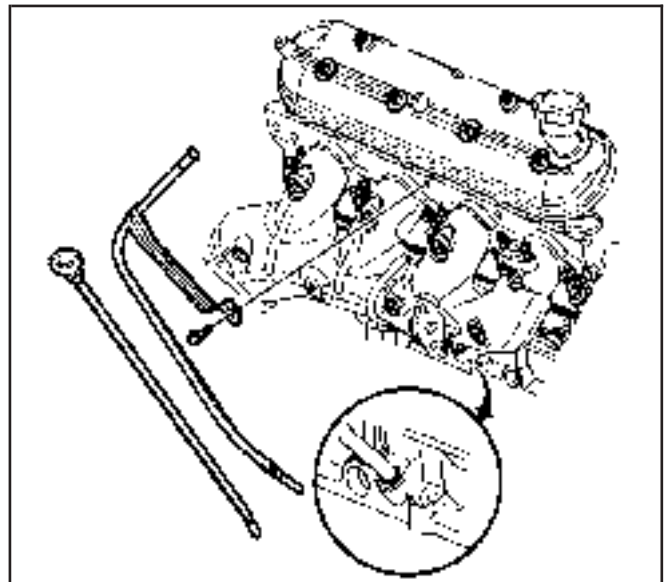
Notice: Refer to *Fastener Notice* in Cautions and Notices.

5. Install the tube bolt.

Tighten

Tighten the oil level indicator tube bolt to 25 N·m (18 lb ft).

6. Install the oil level indicator into the tube.



260114

Engine Flywheel Installation

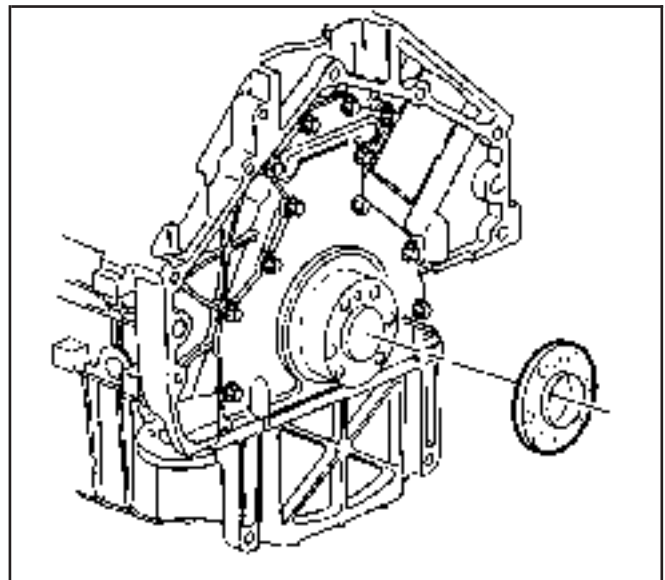
SIE-ID = 824405 LMD = 18-mar-2002

Important:

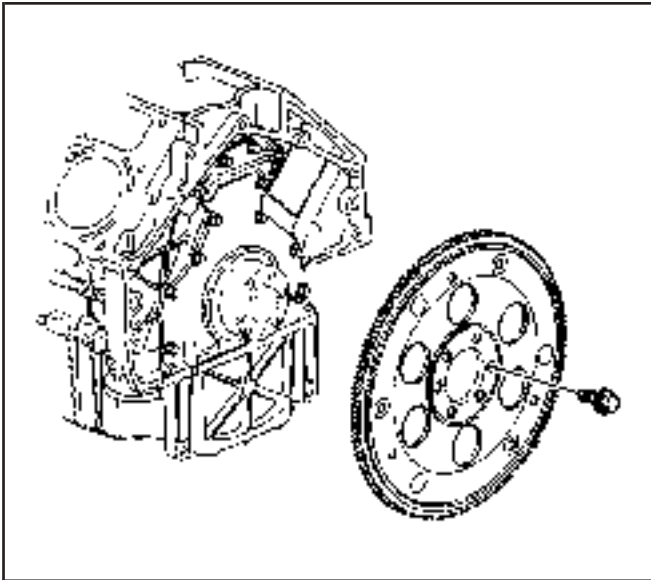
- The flywheel does not use a locating pin for alignment, and will not initially seat against the crankshaft flange or spacer, if applicable, but will be pulled onto the crankshaft by the engine flywheel bolts. This procedure requires a three stage tightening process.
- Certain applications, the 4.8L manual transmission and all 6.0L, require a spacer and longer bolts for proper flywheel position.

1. Install the spacer, if applicable, onto the rear of the crankshaft.

A longer flywheel bolt must be used on applications using a flywheel spacer.



642276

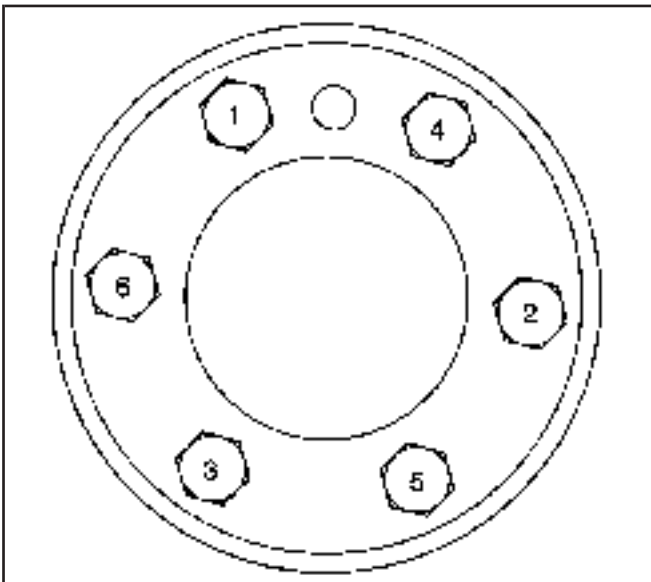


178458

2. Install the automatic transmission engine flywheel to the crankshaft, if applicable.

Important: A longer flywheel bolt must be used on applications using a flywheel spacer.

3. Apply threadlock GM P/N 12345382 (Canadian P/N 10953489) or equivalent to the threads of the flywheel bolts.



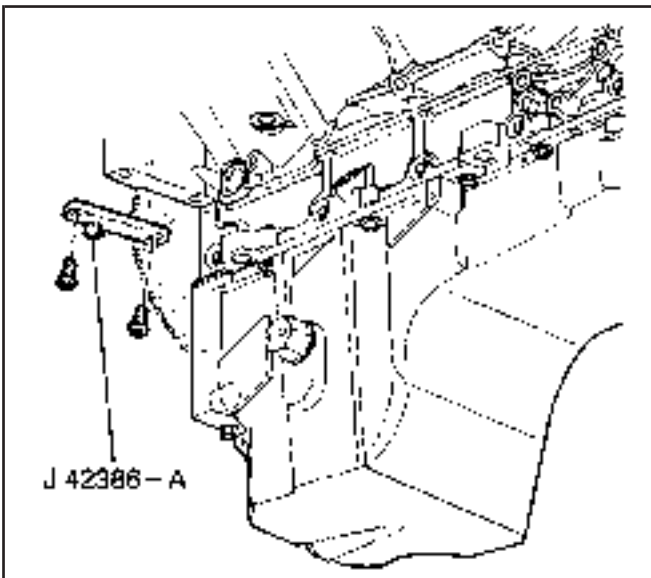
63174

Notice: Refer to *Fastener Notice* in Cautions and Notices.

4. Install the engine flywheel bolts.

Tighten

- 4.1. Tighten the engine flywheel bolts first pass in sequence to 20 N·m (15 lb ft).
- 4.2. Tighten the engine flywheel bolts second pass in sequence to 50 N·m (37 lb ft).
- 4.3. Tighten the engine flywheel bolts final pass in sequence to 100 N·m (74 lb ft).



260126

Crankshaft Balancer Installation

SIE-ID = 281447 LMD = 17-mar-1999

Tools Required

- J 41665 Crankshaft Balancer and Sprocket Installer
- J 36660-A Torque Angle Meter
- J 42386-A Flywheel Holding Tool

Important:

- The crankshaft balancer is balanced as an individual component. It is not necessary to mark the balancer prior to removal.
- The crankshaft balancer installation and bolt tightening involves a four stage tightening process. The first pass ensures that the balancer is installed completely onto the crankshaft. The second, third and fourth passes tighten the new bolt to the proper torque.

- The used crankshaft balancer bolt will be used only during the first pass of the balancer installation procedure. Install a NEW crankshaft balancer bolt and tighten as described in the second, third and fourth passes of the balancer bolt tightening procedure.
- Make sure the teeth of the tool engage the engine flywheel teeth.

Notice: Refer to *Fastener Notice* in Cautions and Notices.

1. Install the *J 42386-A* and bolts.

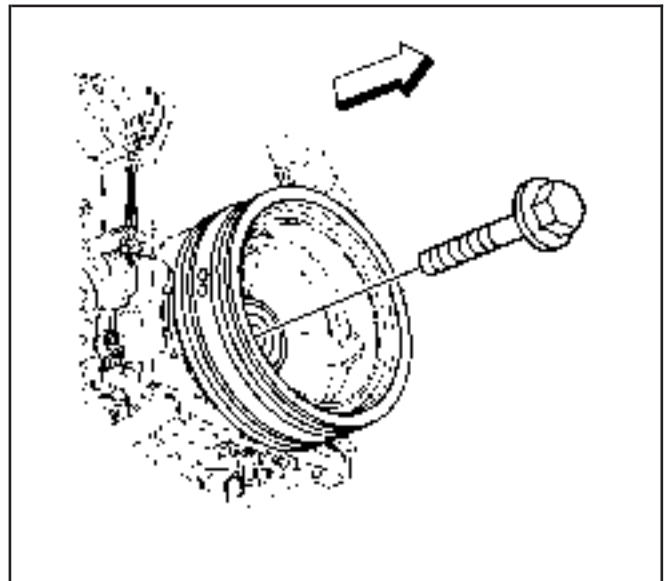
Use one M10-1.5 x 120 mm and one M10-1.5 x 45 mm bolt for proper tool operation.

Tighten

Tighten the *J 42386-A* bolts to 50 N-m (37 lb ft).

Important: The balancer should be positioned onto the end of the crankshaft as straight as possible prior to tool installation.

2. Install the balancer onto the end of the crankshaft.



260154

3. Use the *J 41665* in order to install the balancer.

- 3.1. Assemble the threaded rod, nut, washer and installer.

Insert the smaller end of the installer into the front of the balancer.

- 3.2. Use a wrench and hold the hex end of the threaded rod.

- 3.3. Use a second wrench and rotate the installation tool nut clockwise until the balancer is started onto crankshaft.

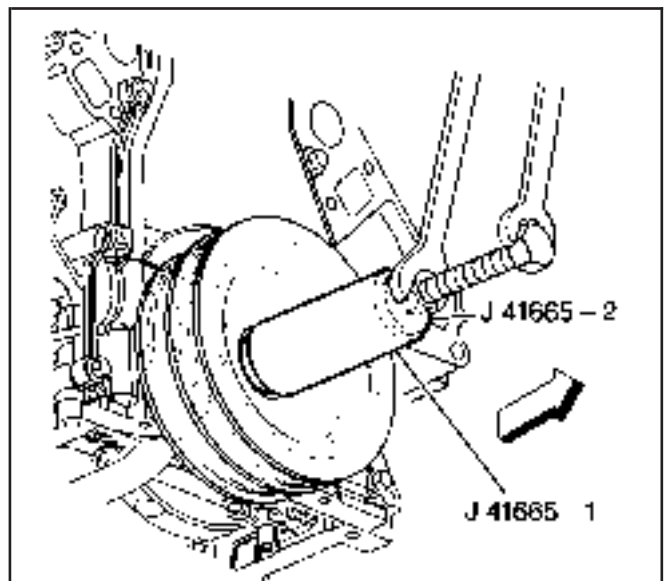
- 3.4. Remove the tool and reverse the installation tool.

Position the larger end of the installer against the front of the balancer.

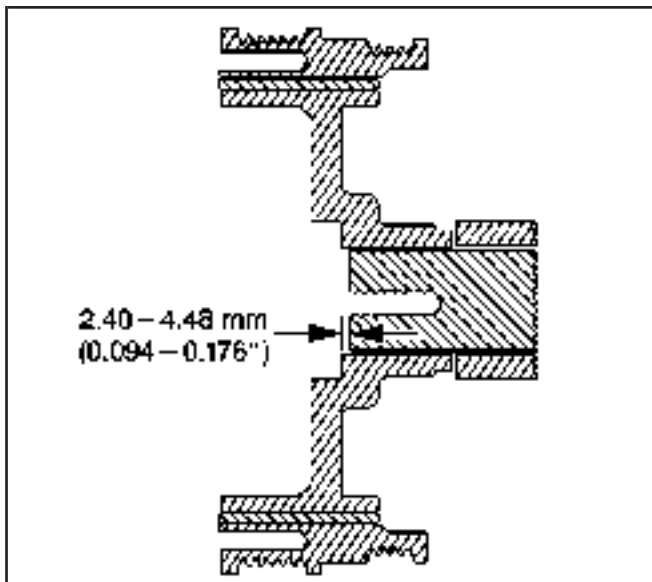
- 3.5. Use a wrench and hold the hex end of the threaded rod.

- 3.6. Use a second wrench and rotate the installation tool nut clockwise until the balancer is installed onto the crankshaft.

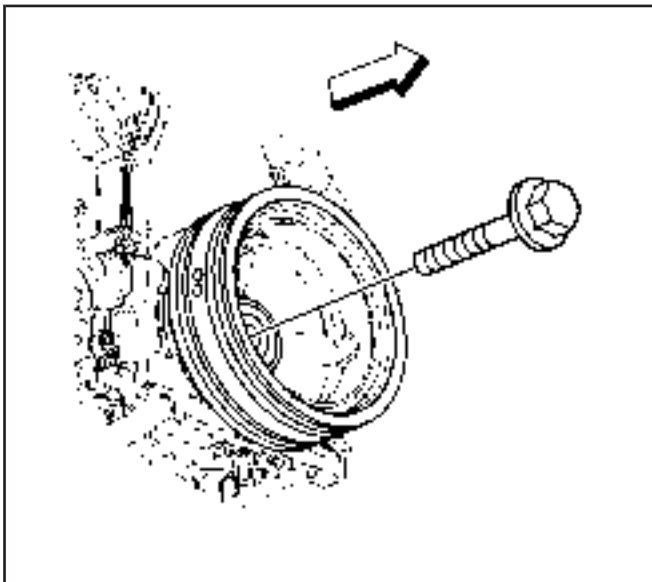
- 3.7. Remove the balancer installation tool.



63187



63245



260154

4. Install the used crankshaft balancer bolt.

Tighten

Tighten the crankshaft balancer bolt to 330 N·m (240 lb ft).

5. Remove the used crankshaft balancer bolt.

Important: The nose of the crankshaft should be recessed 2.4-4.48 mm (0.094-0.176 in) into the balancer bore.

6. Measure for a correctly installed balancer.

If the balancer is not installed to the proper dimensions, install the *J 41665* and repeat the installation procedure.

7. Install the NEW crankshaft balancer bolt.

Tighten

7.1. Tighten the crankshaft balancer bolt a first pass to 50 N·m (37 lb ft).

7.2. Tighten the crankshaft balancer bolt a second pass to 140 degrees using the *J 36660-A*.

8. Remove the *J 42386-A*.

Description and Operation

Crankcase Ventilation System Description

SIE-ID = 879458 LMD = 18-apr-2002

A closed crankcase ventilation system is used in order to provide a more complete scavenging of the crankcase vapors. Fresh air from the throttle body is supplied to the crankcase, mixed with blow-by gases, and then passed through a crankcase ventilation valve into the intake manifold.

The primary control is through the crankcase ventilation valve which meters the flow at a rate depending on manifold vacuum. To maintain idle quality, the crankcase ventilation valve restricts the flow when intake manifold vacuum is high. If abnormal operating conditions arise, the system is designed to allow excessive amounts of blow-by gases to back flow through the crankcase vent tube into the engine air inlet to be consumed by normal combustion.

Filtered fresh air is routed from up-stream of the throttle blade to the front of the right rocker arm cover via a formed rubber hose. To reduce the potential of oil pullover into the throttle bore area due to back flow of the ventilation system, the fitting in the right rocker arm cover is shielded from the rocker arms. From there fresh air and gases are routed through the crankcase and up to the opposite rocker arm cover where the positive crankcase ventilation (PCV) valve is located. Gases are then routed through a hose to the intake manifold.

Drive Belt System Description

SIE-ID = 558948 LMD = 27-jun-2000

The drive belt system consists of the following components:

- The drive belt
- The drive belt tensioner
- The drive belt idler pulley

- The crankshaft balancer pulley
- The accessory drive component mounting brackets
- The accessory drive components
 - The power steering pump, if belt driven
 - The generator
 - The A/C compressor, if equipped
 - The engine cooling fan, if belt driven
 - The water pump, if belt driven
 - The vacuum pump, if equipped
 - The air compressor, if equipped

The drive belt system may use 1 belt or 2 belts. The drive belt is thin so that it can bend backwards and has several ribs to match the grooves in the pulleys. There also may be a V-belt style belt used to drive certain accessory drive components. The drive belts are made of different types of rubbers — chloroprene or EPDM — and have different layers or plys containing either fiber cloth or cords for reinforcement.

Both sides of the drive belt may be used to drive the different accessory drive components. When the back side of the drive belt is used to drive a pulley, the pulley is smooth.

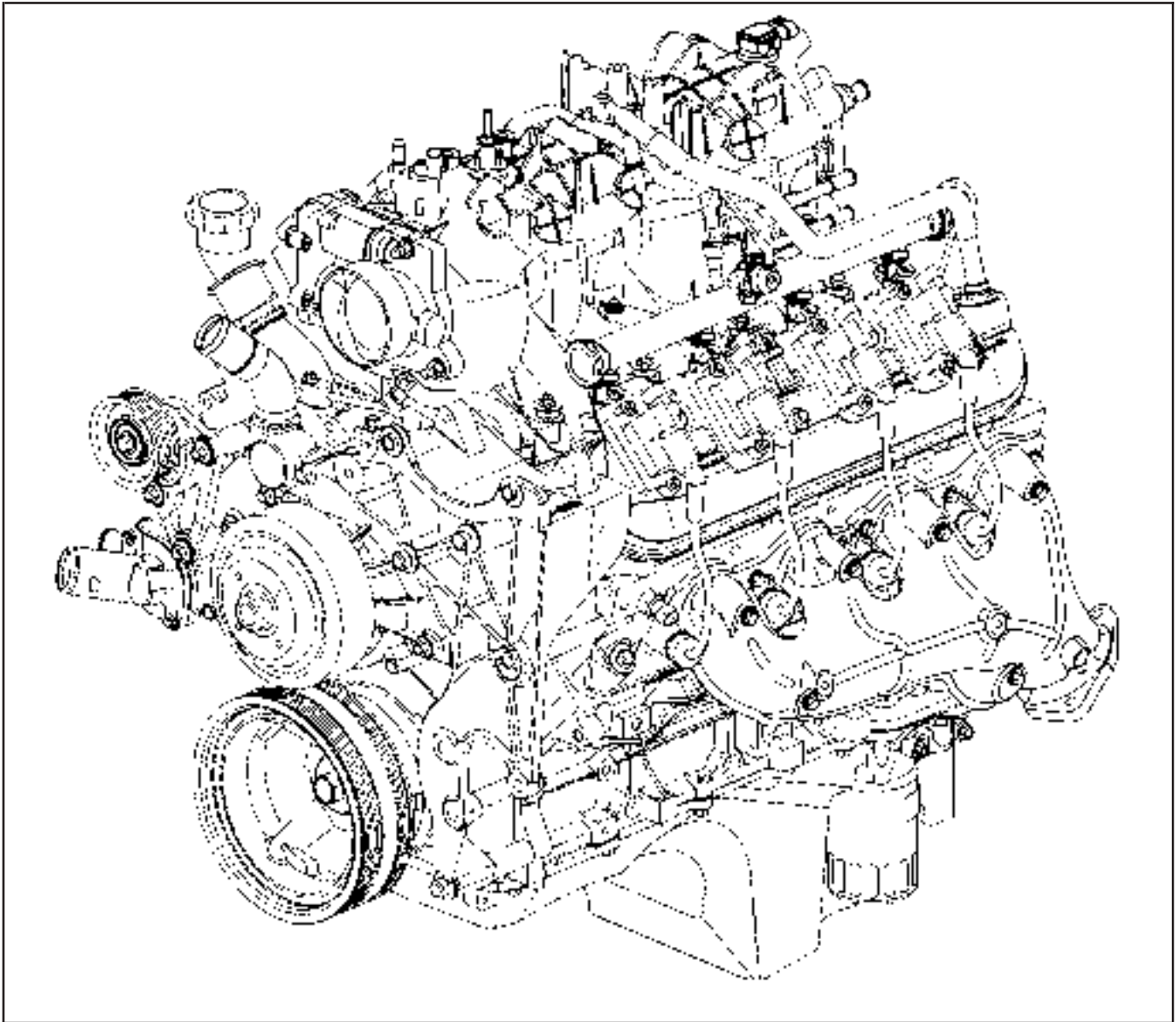
The drive belt is pulled by the crankshaft balancer pulley across the accessory drive component pulleys. The spring loaded drive belt tensioner keeps constant tension on the drive belt to prevent the drive belt from slipping. The drive belt tensioner arm will move when loads are applied to the drive belt by the accessory drive components and the crankshaft.

The drive belt system may have an idler pulley, which is used to add wrap to the adjacent pulleys. Some systems use an idler pulley in place of an accessory drive component when the vehicle is not equipped with the accessory.

Engine Component Description

SIE-ID = 824406 LMD = 19-mar-2002

The 4.8/5.3/6.0 Liter V 8 Engines SIO-ID = 869572 LMD = 18-mar-2002



863071

The 4.8/5.3/6.0 Liter V 8 engines are identified as RPO LR4 VIN V (4.8), RPO LM7 VIN T (5.3), RPO L59 VIN Z (5.3), RPO LQ4 VIN U (6.0), and RPO LQ9 VIN N (6.0).

Camshaft and Drive System

A billet steel one piece camshaft is supported by five bearings pressed into the engine block. The camshaft has a machined camshaft sensor reluctor ring incorporated between the fourth and fifth bearing journals. The camshaft timing sprocket is mounted to the front of the camshaft and is driven by the crankshaft sprocket through the camshaft timing chain. The splined crankshaft sprocket is positioned to the crankshaft by a key and keyway. The crankshaft

sprocket splines drive the oil pump driven gear. A retaining plate mounted to the front of the engine block maintains camshaft location.

Crankshaft

The crankshaft is cast nodular iron. The crankshaft is supported by five crankshaft bearings. The bearings are retained by crankshaft bearing caps which are machined with the engine block for proper alignment and clearance. The crankshaft journals are undercut and rolled. The center main journal is the thrust journal. A crankshaft position reluctor ring is press fit mounted at the rear of the crankshaft. The reluctor ring is not serviceable separately. All crankshafts will have a short rear flange, at the crankshaft rear oil seal area. Certain 4.8L manual transmissions and 6.0L applications require a spacer

between the rear of the crankshaft and the flywheel for proper flywheel positioning. Longer bolts are required in applications using the spacer.

Cylinder Heads

The cylinder heads are cast aluminum and have pressed in place powdered metal valve guides and valve seats. Passages for the engine coolant air bleed system are at the front of each cylinder head. The valve rocker arm covers are retained to the cylinder head by four center mounted rocker arm cover bolts.

Engine Block

The engine block is a cam-in-block deep skirt 90 degree V configuration with five crankshaft bearing caps. The engine block is cast iron. The five crankshaft bearing caps each have four vertical M10 and two horizontal M8 mounting bolts. The camshaft is supported by five camshaft bearings pressed into the block.

Exhaust Manifolds

The exhaust manifolds are a one piece cast iron design. The exhaust manifolds direct exhaust gasses from the combustion chambers to the exhaust system. Each manifold also has an externally mounted heat shield that is retained by bolts.

Intake Manifold

The intake manifold is a one piece composite design that incorporates brass threaded inserts for mounting the fuel rail, throttle cable bracket, throttle body, evaporative emission (EVAP) solenoid, wire harness stud, engine sight shield and sight shield bracket. Each side of the intake manifold is sealed to the cylinder head by a nonreusable silicone sealing gasket and nylon carrier assembly. The electronically actuated throttle body bolts to the front of the intake manifold. The throttle body is sealed by a one piece push in place silicone gasket. The fuel rail assembly with eight separate fuel injectors is retained to the intake by four bolts. The injectors are seated into their individual manifold bores with O-ring seals to provide sealing. A fuel rail stop bracket is retained to the rear of the left cylinder head by a mounting bolt. The manifold absolute pressure (MAP) sensor is installed and retained to the top rear of the intake manifold and sealed by an O-ring seal. The EVAP solenoid is mounted to the top front of the intake manifold and retained by one bolt. There are no coolant passages within the intake manifold.

Oil Pan

The structural oil pan is cast aluminum. Incorporated into the design are the oil filter mounting boss, drain plug opening, oil level sensor mounting bore, and oil pan baffle. The oil pan transfer cover and oil level sensor mount to the sides of the oil pan. The alignment of the structural oil pan to the rear of the engine block and transmission bell housing is critical.

Piston and Connecting Rod Assembly

The pistons are cast aluminum. The pistons use two compression rings and one oil control ring assembly. The piston is a low friction, lightweight

design with a flat or recessed top and barrel shaped skirt. The piston pins are chromium steel, have floating fit in the piston, and are retained by a press fit in the connecting rod. 6.0L LQ9 applications will have full-floating pistons/pins retained by internal clips. The connecting rods are powdered metal. The connecting rods are fractured at the connecting rod journal and then machined for the proper clearance. 2003 applications use a piston with a graphite coated skirt.

Valve Rocker Arm Cover Assemblies

The valve rocker arm covers are cast aluminum and use a pre-molded silicon gasket for sealing. Mounted to each rocker cover are the coil and bracket assemblies. Incorporated into the covers are the oil fill tube, the positive crankcase ventilation (PCV) system passages, and the engine fresh air passages.

Valve Train

Motion is transmitted from the camshaft through the hydraulic roller valve lifters and tubular pushrods to the roller type rocker arms. The nylon valve lifter guides position and retain the valve lifters. The valve rocker arms for each bank of cylinders are mounted on pedestals, pivot supports. Each rocker arm is retained on the pivot support and cylinder head by a bolt. Valve lash is net build.

New Product Information

SIE-ID = 823848 LMD = 18-mar-2002

The purpose of New Product Information is to highlight or indicate important product changes from the previous model year.

Changes may include one or more of the following items:

- Torque values and/or fastener tightening strategies
- Changed engine specifications
- New sealants and/or adhesives
- Disassembly and assembly procedure revisions
- Engine mechanical diagnostic procedure revisions
- New special tools required
- A component comparison from the previous year

Torque Values and/or Fastener Tightening Strategies

- All fasteners and threaded holes on the 4.8/5.3/6.0 liter engines utilize metric threads.
- Cylinder head, connecting rod, crankshaft balancer, and main bearing cap bolts now apply a torque angle strategy.
- Certain fasteners should not be reused. Bolts, studs, or other fasteners that must be replaced will be called out in the specific service procedure.
- Refer to *Fastener Tightening Specifications* and *Thread Repair Specifications*.

New Sealants and/or Adhesives

Canadian SPO Part Numbers have been added.

Changed Engine Specifications

Engine specification tables content and format have been commonized.

Disassembly and Assembly Procedure Revisions

For certain applications, a spacer plate has been added between the flywheel and rear of the crankshaft. It is necessary to remove the spacer plate prior to removal and installation of the crankshaft rear oil seal and clutch pilot bearing.

Engine Mechanical Diagnostic Procedure Revisions

All diagnosis on a vehicle should follow a logical process. Strategy based diagnostics is a uniform approach for repairing all systems. The diagnostic flow may always be used in order to resolve a system problem. The diagnostic flow is the place to start when repairs are necessary. For a detailed explanation, refer to *Strategy Based Diagnosis* in General Information or *Diagnostic Starting Point - Engine Mechanical* in Engine Mechanical.

New Special Tools Required

- A variety of new tools have been developed to assist in engine disassembly, assembly, and on-vehicle service.

- *J 43690* and *J 43690-100* have been developed to measure connecting rod bearing clearances. Refer to *Camshaft and Bearings Cleaning and Inspection*.
- A cylinder leakage test, using *J 35667-A*, has been developed. Refer to *Cylinder Leakage Test*.
- *J 45299* has been developed to prelube new or remanufactured engines/bearings prior to engine installation. Refer to *Engine Prelubing*.
- Refer to *Special Tools*.

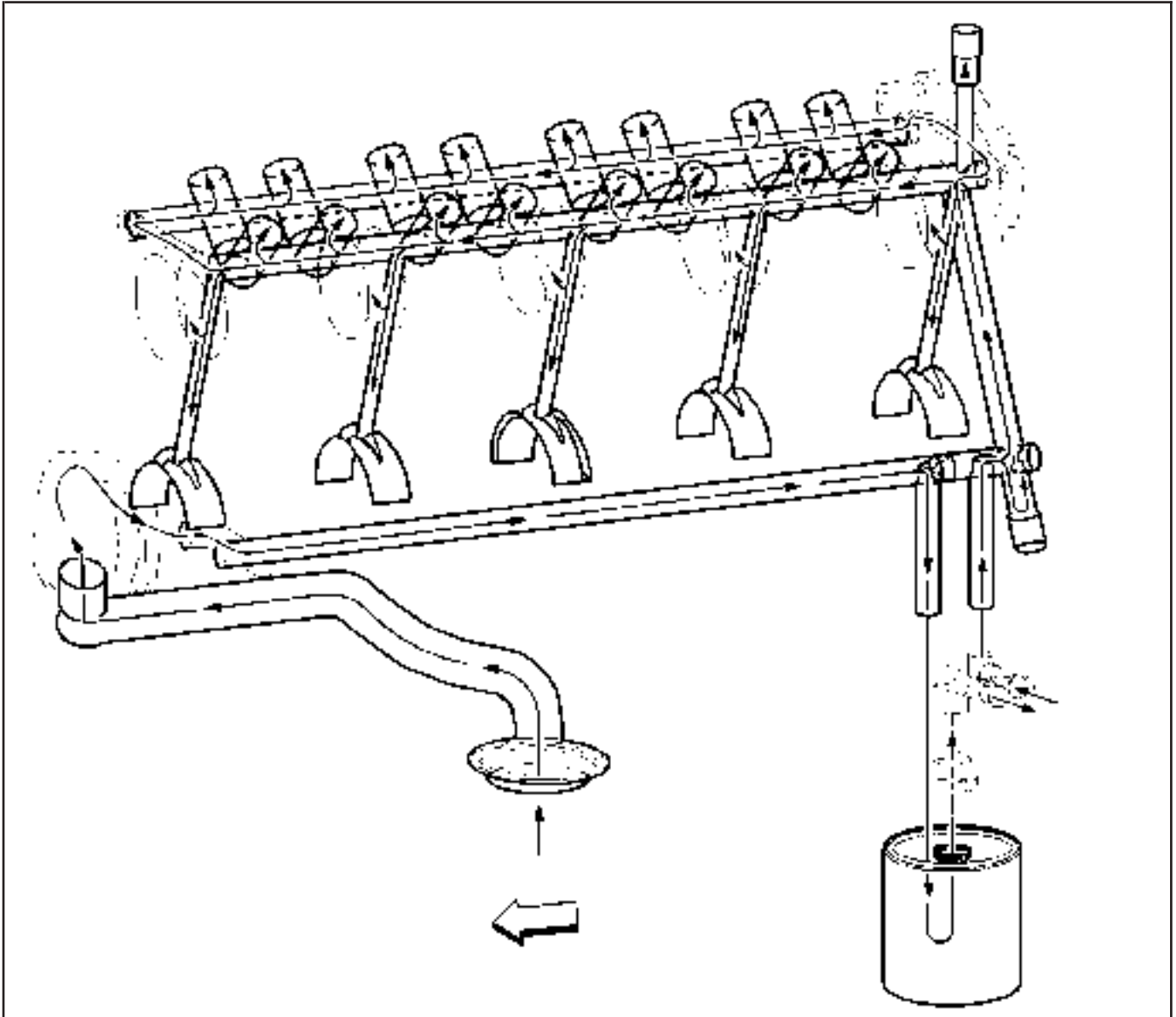
A Component Comparison from the Previous Year

- Exhaust gas recirculation (EGR) system has been deleted on all applications.
- A spacer plate between the crankshaft and flywheel is required for applications using the 4L80-E transmission.
- All 2003 applications use a piston with a graphite coated skirt.

Lubrication Description

SIE-ID = 644201 LMD = 19-apr-2002

Lubrication Flow Schematic



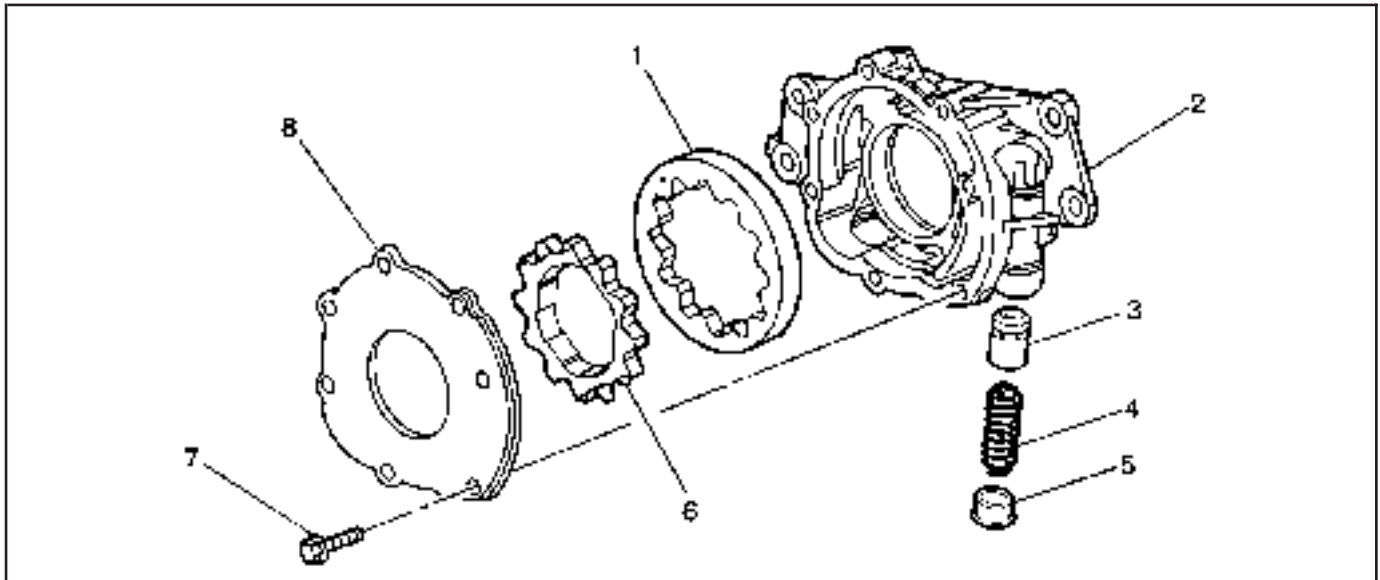
260167

Engine lubrication is supplied by a gerotor type oil pump assembly. The pump is mounted on the front of the engine block and driven directly by the crankshaft sprocket. The pump gears rotate and draw oil from the oil pan sump through a pick-up screen and pipe. The oil is pressurized as it passes through the pump and is sent through the engine block oil galleries. Contained within the oil pump assembly is a pressure relief valve that maintains oil pressure within a specified range. Pressurized oil is directed through the lower gallery to the full flow oil filter where harmful contaminants are removed. A bypass valve is incorporated into the oil pan, at the oil filter boss, which will permit oil flow in the event the filter becomes restricted. At the rear of the block, oil is then directed to the upper main oil galleries which are drilled just above the camshaft assembly. From there oil is then directed to the crankshaft and camshaft bearings.

Oil that has entered the upper main oil galleries also pressurizes the valve lifter assemblies and is then pumped through the pushrods to lubricate the valve rocker arms and valve stems. Oil returning to the pan is directed by the crankshaft oil deflector. Oil pressure and crankcase level are each monitored by individual sensors.

An external oil cooler is available on certain applications, all 6.0L. Oil is directed from the oil pump, through the lower main oil gallery to the full flow oil filter. Oil is then directed through the oil pan outlet oil gallery, located in the left rear of the oil pan, and to the external oil cooler via a hose assembly. Oil flows through the oil cooler and returns to the engine at the oil pan inlet oil gallery, located in the left rear of the oil pan. Oil is then directed to the upper main oil galleries and the remainder of the engine assembly.

Oil Pump Assembly SIO-ID = 101820 LMD = 13-aug-1996



64190

Legend

- | | |
|----------------------------------|----------------|
| (1) Driven Gear | (5) Plug |
| (2) Oil Pump Housing | (6) Drive Gear |
| (3) Pressure Relief Valve | (7) Cover Bolt |
| (4) Pressure Relief Valve Spring | (8) Cover |

Cleanliness and Care

SIE-ID = 797199 LMD = 18-mar-2002

- Throughout this section, it should be understood that proper cleaning and protection of machined surfaces and friction areas is part of the repair procedure. This is considered standard shop practice even if not specifically stated.
- When any internal engine parts are serviced, care and cleanliness is important.
- When components are removed for service, they should be marked, organized or retained in a specific order for assembly. Refer to *Separating Parts*.
- At the time of installation, components should be installed in the same location and with the same mating surface as when removed.
- An automobile engine is a combination of many machined, honed, polished and lapped surfaces with tolerances that are measured in millimeters or thousandths of an inch. These surfaces should be covered or protected to avoid component damage.
- A liberal coating of clean engine oil should be applied to friction areas during assembly.
- Proper lubrication will protect and lubricate friction surfaces during initial operation.

Separating Parts

SIE-ID = 74174 LMD = 18-mar-2002

Important: Many internal engine components will develop specific wear patterns on their friction surfaces.

When disassembling the engine, internal components **MUST** be separated, marked, or organized in a way to ensure installation to their original location and position.

Separate, mark, or organize the following components:

- Piston and the piston pin
- Piston to the specific cylinder bore
- Piston rings to the piston
- Connecting rod to the crankshaft journal
- Connecting rod to the bearing cap
A paint stick or etching/engraving type tool are recommended. Stamping the connecting rod or cap near the bearing bore may affect component geometry.
- Crankshaft main and connecting rod bearings
- Camshaft and valve lifters
- Valve lifters, lifter guides, pushrods and rocker arm assemblies
- Valve to the valve guide
- Valve spring and shim to the cylinder head location
- Engine block main bearing cap location and direction
- Oil pump drive and driven gears

Replacing Engine Gaskets

SIE-ID = 869807 LMD = 18-mar-2002

Tools Required

J 28410 Gasket Remover

Gasket Use and Applying Sealants

- Do not use any gasket again unless specified.
- Gaskets that can be used again will be identified in the service procedure.
- Do not apply sealant to any gasket or sealing surface unless called out in the service information.

Separating Components

- Use a rubber mallet to separate components.
- Bump the part sideways to loosen the components.
- Bumping should be done at bends or reinforced areas to prevent distortion of parts.

Cleaning Gasket Surfaces

- Remove all gasket and sealing material from the part using the *J 28410* or equivalent.
- Care must be used to avoid gouging or scraping the sealing surfaces.
- Do not use any other method or technique to remove sealant or gasket material from a part.
- Do not use abrasive pads, sand paper, or power tools to clean the gasket surfaces.
 - These methods of cleaning can cause damage to the component sealing surfaces.
 - Abrasive pads also produce a fine grit that the oil filter cannot remove from the oil.
 - This grit is abrasive and has been known to cause internal engine damage.

Assembling Components

Notice: Refer to *Sealant Notice* in Cautions and Notices.

- When assembling components, use only the sealant specified or equivalent in the service procedure.
- Sealing surfaces should be clean and free of debris or oil.
- Specific components such as crankshaft oil seals or valve stem oil seals may require lubrication during assembly.
- Components requiring lubrication will be identified in the service procedure.
- When applying sealant to a component, apply the amount specified in the service procedure.
- Tighten bolts to specifications. Do not overtighten.

Use of RTV and Anaerobic Sealer

SIE-ID = 869808 LMD = 18-mar-2002

Pipe Joint Compound

Important: Three types of sealer are commonly used in engines. These are Room Temperature Vulcanizing (RTV) sealer, anaerobic gasket eliminator sealer, and pipe joint compound. The correct sealer and amount must be used in the proper location to prevent oil leaks. DO NOT interchange the 3 types of sealers. Use only the specific sealer or the equivalent as recommended in the service procedure.

- Pipe joint compound is a pliable sealer that does not completely harden. This type sealer is used where two non-rigid parts, such as the oil pan and the engine block, are assembled together.
- Do not use pipe joint compound in areas where extreme temperatures are expected. These areas include: exhaust manifold, head gasket, or other surfaces where gasket eliminator is specified.
- Follow all safety recommendations and directions that are on the container.

To remove the sealant or the gasket material, refer to *Replacing Engine Gaskets*.

Notice: Refer to *Sealant Notice* in Cautions and Notices.

- Apply the pipe joint compound to a clean surface. Use a bead size or quantity as specified in the procedure. Run the bead to the inside of any bolt holes.
- Apply a continuous bead of pipe joint compound to one sealing surface. Sealing surfaces to be resealed must be clean and dry.
- Tighten the bolts to specifications. Do not overtighten.

RTV Sealer

- RTV sealant hardens when exposed to air. This type sealer is used where two non-rigid parts, such as the intake manifold and the engine block, are assembled together.
- Do not use RTV sealant in areas where extreme temperatures are expected. These areas include: exhaust manifold, head gasket, or other surfaces where a gasket eliminator is specified.
- Follow all safety recommendations and directions that are on the container.

To remove the sealant or the gasket material, refer to *Replacing Engine Gaskets*.

Notice: Refer to *Sealant Notice* in Cautions and Notices.

- Apply RTV to a clean surface. Use a bead size as specified in the procedure. Run the bead to the inside of any bolt holes.
- Assemble components while RTV is still wet, within 3 minutes. Do not wait for RTV to skin over.
- Tighten bolts to specifications. Do not overtighten.

Anaerobic Sealer

- Anaerobic gasket eliminator hardens in the absence of air. This type sealer is used where two rigid parts, such as castings, are assembled

together. When two rigid parts are disassembled and no sealer or gasket is readily noticeable, the parts were probably assembled using a gasket eliminator.

- Follow all safety recommendations and directions that are on the container.

To remove the sealant or the gasket material, refer to *Replacing Engine Gaskets*.

- Apply a continuous bead of gasket eliminator to one flange. Surfaces to be sealed must be clean and dry.

Notice: Refer to *Sealant Notice* in Cautions and Notices.

- Spread the sealer evenly with your finger to get a uniform coating on the sealing surface.

Important: Anaerobic sealed joints that are partially torqued and allowed to cure more than five minutes may result in incorrect shimming and sealing of the joint.

- Tighten bolts to specifications. Do not overtighten.
- After properly tightening the fasteners, remove the excess sealer from the outside of the joint.

Tools and Equipment

SIE-ID = 73997 LMD = 26-feb-2002

Special tools are listed and illustrated throughout this section with a complete listing at the end of the section. These tools, or their equivalents, are specially designed to quickly and safely accomplish the operations for which they are intended. The use of these special tools will also minimize possible damage to engine components. Some precision measuring tools are required for inspection of certain critical components. Torque wrenches and a torque angle meter are necessary for the proper tightening of various fasteners.

To properly service the engine assembly, the following items should be readily available:

- Approved eye protection and safety gloves
- A clean, well lit, work area
- A suitable parts cleaning tank
- A compressed air supply
- Trays or storage containers to keep parts and fasteners organized
- An adequate set of hand tools
- Approved engine repair stand
- An approved engine lifting device that will adequately support the weight of the components

Special Tools and Equipment

SIE-ID = 824407 LMD = 03-jun-2002



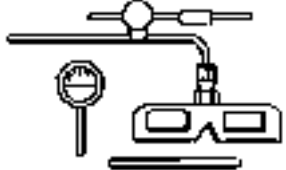
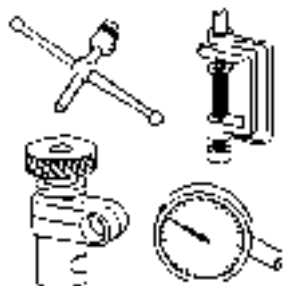
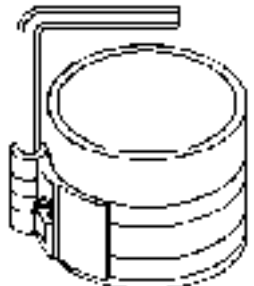
Illustration	Tool Number/ Description
 <p>14487</p>	J 3049-A Valve Lifter Remover
 <p>166875</p>	J 6125-1B Slide Hammer
 <p>35463</p>	J 7872 Magnetic Base Dial Indicator Set
 <p>2014</p>	J 8001 Dial Indicator Set
 <p>3403</p>	J 8037 Piston Ring Compressor


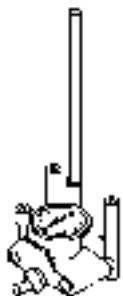
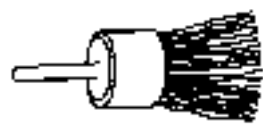

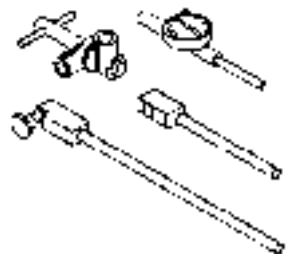
Illustration	Tool Number/ Description
 <p>3414</p>	J 8062 Valve Spring Compressor – Head Off
 <p>5110</p>	J 8087 Cylinder Bore Gage
 <p>4994</p>	J 8089 Carbon Removal Brush
 <p>216164</p>	J 8433-1 Two Jaw Puller
 <p>3408</p>	J 8520 Cam Lobe Lift Indicator

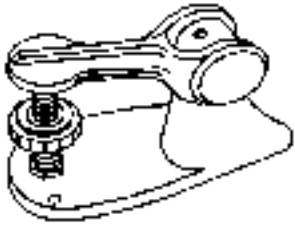
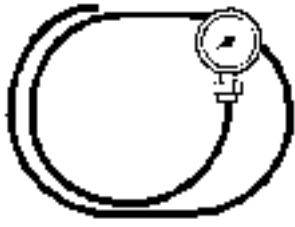

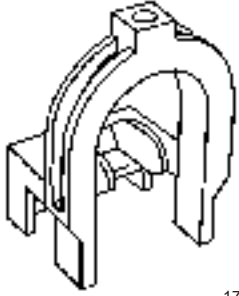
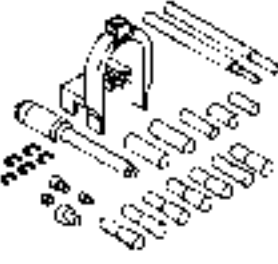
Illustration	Tool Number/ Description
 <p>4997</p>	<p>J 9666 Valve Spring Tester</p>
 <p>29339</p>	<p>J 21867 Pressure Gage</p>
 <p>178379</p>	<p>J 24086-9 Adjustable Installer</p>
 <p>178381</p>	<p>J 24086-10 Piston Pin Remover/Installer Base</p>
 <p>14495</p>	<p>J 24086-C Piston Pin Remover/Installer Set</p>


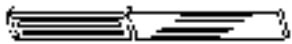
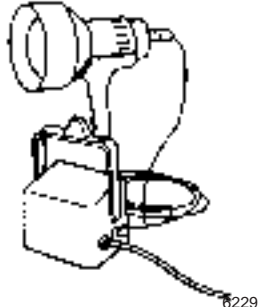
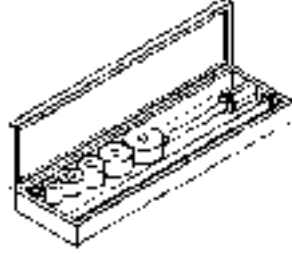

Illustration	Tool Number/ Description
 <p>3412</p>	<p>J 24270 Cylinder Bore Ridge Reamer</p>
 <p>52126</p>	<p>J 28410 Gasket Remover</p>
 <p>62292</p>	<p>J 28428-E High Intensity Black Light Kit</p>
 <p>5118</p>	<p>J 33049 Camshaft Bearing Service Set</p>
 <p>62295</p>	<p>J 35667-A Cylinder Head Leakdown Tester</p>

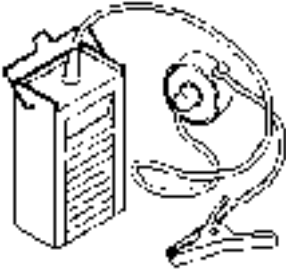

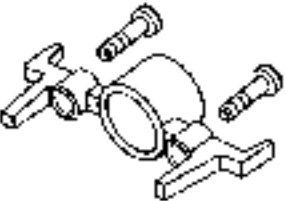
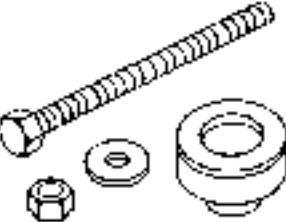

Illustration	Tool Number/ Description
 <p>3413</p>	<p>J 36660-A Torque Angle Meter</p>
 <p>596942</p>	<p>J 37378-1 Valve Guide Reamer</p>
 <p>64207</p>	<p>J 41476 Front and Rear Cover Alignment Tool</p>
 <p>64248</p>	<p>J 41478 Crankshaft Front Oil Seal Installer</p>
 <p>64249</p>	<p>J 41479 Crankshaft Rear Oil Seal Installer</p>

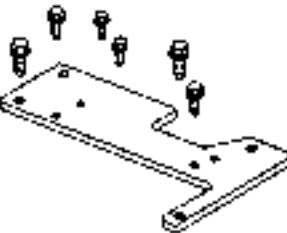
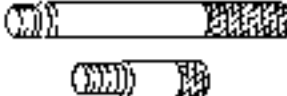


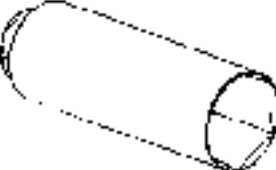
Illustration	Tool Number/ Description
 <p>64211</p>	<p>J 41480 Front and Rear Cover Alignment</p>
 <p>64260</p>	<p>J 41556 Connecting Rod Guide</p>
 <p>98060</p>	<p>J 41558 Crankshaft Sprocket Remover</p>
 <p>64240</p>	<p>J 41665 Crankshaft Balancer and Sprocket Installer</p>
 <p>67136</p>	<p>J 41712 Oil Pressure Switch Socket</p>

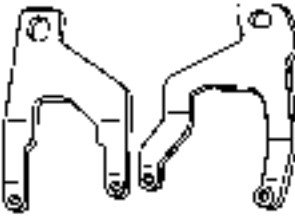
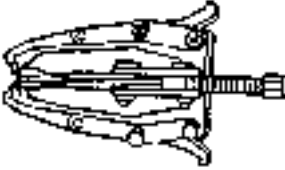

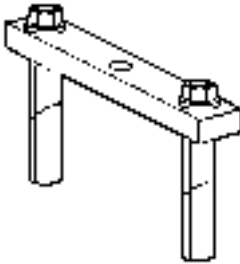

Illustration	Tool Number/ Description
 <p data-bbox="396 478 444 499">74283</p>	<p data-bbox="516 310 727 373">J 41798 Engine Lift Bracket</p>
 <p data-bbox="396 810 444 831">99086</p>	<p data-bbox="508 632 735 716">J 41816 Crankshaft Balancer Remover</p>
 <p data-bbox="391 1142 440 1163">142148</p>	<p data-bbox="483 974 751 1037">J 41816-2 Crankshaft End Protector</p>
 <p data-bbox="396 1474 444 1495">98072</p>	<p data-bbox="488 1293 748 1377">J 41818 Crankshaft Bearing Cap Remover</p>
 <p data-bbox="391 1801 440 1822">340279</p>	<p data-bbox="492 1623 745 1707">J 42385-100 Head/Main Bolt Thread Repair Kit</p>





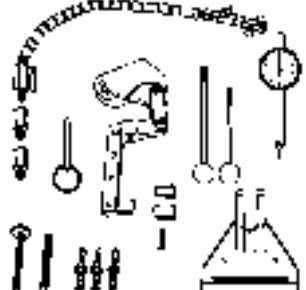
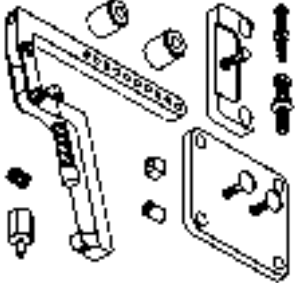

Illustration	Tool Number/ Description
 <p data-bbox="1101 478 1149 499">453049</p>	<p data-bbox="1182 310 1484 373">J 42385-200 Common Thread Repair Kit</p>
 <p data-bbox="1101 810 1149 831">453073</p>	<p data-bbox="1190 642 1476 705">J 42385-300 Fixtures and Hardware Kit</p>
 <p data-bbox="1110 1142 1159 1163">99089</p>	<p data-bbox="1211 974 1455 1037">J 42386-A Flywheel Holding Tool</p>
 <p data-bbox="1101 1474 1149 1495">369719</p>	<p data-bbox="1227 1304 1438 1367">J 42907 Oil Pressure Tester</p>
 <p data-bbox="1101 1801 1149 1822">650651</p>	<p data-bbox="1203 1623 1459 1707">J 43690 Rod Bearing Clearance Checking Tool</p>

Illustration	Tool Number/ Description
 <p data-bbox="386 478 444 499">863073</p>	<p data-bbox="467 302 760 386">J 43690-100 Rod Bearing Checking Tool - Adapter Kit</p>
 <p data-bbox="386 814 444 835">852797</p>	<p data-bbox="532 646 711 709">J 45299 Engine Preluber</p>