



OWNER'S OPERATION AND MAINTENANCE MANUAL



**This Page
Was Intentionally
Left Blank**



Thank you for your selection of Pleasurecraft (PCM) Marine Power for your boating needs. We welcome you to Team PCM, which puts you in the company of tens of thousands of boaters who have relied on Pleasurecraft inboards as their power of choice for over 30 years.

When you chose PCM, you selected the utmost in premium power for your boating application. Pleasurecraft is the world's largest manufacturer of gasoline marine inboards, and the clear-cut leader in cutting edge technology. Over the years, we have introduced many breakthrough innovations that quickly became industry standards. The pyramidal exhaust system, light-weight transmission, computerized engine control and the Fuel Control Cell (FCC) are all PCM innovations. No matter which PCM model you purchased, you can be sure it is equipped with the latest in modern technology for added performance and durability.

READ THIS MANUAL THOROUGHLY

Before starting your engine(s), READ THIS MANUAL CAREFULLY AND COMPLETELY. If you do not understand any portion of the manual, contact your Dealer for clarification or assistance. Ask your Dealer for a demonstration of actual starting and operating procedures.

The descriptions and specifications contained in this manual were in effect at the time of printing. PCM Engines' policy of continued improvement reserves the right to change specifications or design without notice and without obligation.

This manual will cover the following 2017 Boat Model Year engines:

Model

5.3L DI Catanium™ CES

6.2L DI Catanium™ CES

*** PCM's Catanium™ Clean Emission System is available to reduce emissions without diminishing performance. Catanium™ CES is patented catalyst technology which uses precious metals to create clean emissions and greatly reduce dangerous carbon monoxide gases.**

PROPOSITION 65



WARNING

The engine exhaust from this product contains chemicals known to the State of California to cause cancer, birth defects or other reproductive harm.

TABLE OF CONTENTS

INTRODUCTION	3-9
Registration Information (Warranty Registration Card is located at the back of this manual)	3
5-Year Transferable Limited Warranty	4
Federal/California Emission Control Warranty Statement	5
PCM Inboard Marine Engine General Emissions Warranty Coverage	6
Safety Information	9
Replacement Parts	9
Safety Warnings	9
BOATING RESPONSIBILITIES	10-12
Carbon Monoxide Hazard	10
Safe Boating Suggestions	11
Water Wisdom	11
Operation and Maintenance	11
Rules of the Road	12
ENGINE IDENTIFICATION	13-14
Engine Identification	13
Engine Model Identification / Advisory	14
Owner Identification and Registration Information	14
ELECTRONIC FUEL INJECTION INFORMATION	15
Electronic Fuel Injection System	15
Engine Alarm System	15
OPERATING INSTRUCTIONS	16-18
Instrumentation	16
Starting Engine (Fuel Injected Engines)	16
Electronic Speed Control	18
Shifting Transmission	18
Freezing Temperature Operation	18
Operation in High Debris Areas	18
CONDITIONS AFFECTING OPERATION	19
Weight Distribution	19
Boat Bottom	19
Propeller Selection	19
ENGINE BREAK-IN PERIOD	20
25-HOUR ENGINE INSPECTION	21
FUEL REQUIREMENTS	22
Gasoline Requirements	22
Gasoline Containing Alcohol	22
OIL REQUIREMENTS	23
Engine Oil Recommendations	23
Transmission and "V"-Drive Oil Requirements	23
ENGINE MAINTENANCE	24-46
Engine Maintenance	26
Checking Fluid Levels	24-26

TABLE OF CONTENTS

Electrical System Relay and Fuse Block	26
Electrical System Fuses	26
Boat's Ignition Fuse	26
Electrical System Wiring and Connectors	26
Battery	27
Cooling System Sacrificial Anode	28
Checking Coolant Level	28
Testing Coolant For Alkalinity	28
Flushing Cooling System - Sea-Water Section	29
Draining Fresh-Water Cooling System	29
Inspect and Clean Exhaust System Cooling Thermostat	30
Cleaning Sea-Water Section of Heat Exchanger (Fresh-Water Cooled Applications Only)	30
Fuel System Description	31
Fuel Control Cell (FCC) Fuel System	31
Servicing the FCC	32
Primary Fuel Filter (FCC Clamp-on Canister)	33-34
Servicing Fuel Pre-Filter	34
Priming Fuel System	34
Flame Arrestor	34
Accessory Drive Belt	35
Servicing Raw Water Pump Impeller	36
Changing Oils	36
Engine Alignment	38-41
Engine Maintenance Log	42
Maintenance Schedule	43-44
Visual Inspection	45
Engine Fluid Capacities	45
Transmission Fluid Capacities	45
Filter and Accessory Requirements	46
ENGINE SPECIFICATIONS	47-48
OUT-OF-SEASON STORAGE	49-51
Engine Storage	49
Draining Instructions	50
Battery Storage	50
Recommissioning After Storage	51
TROUBLESHOOTING	52-54
RAW WATER DRAINING LOCATIONS	55-56
HEATER CONNECTIONS	57
INSTRUMENTATION WIRING DIAGRAM	58
LITERATURE	59
FORMS	60-63
NOTES	64
WARRANTY/REGISTRATION CARD .	

REGISTRATION INFORMATION

(Warranty Registration Card is located at the back of this manual)

Shortly after your purchase is registered with PCM, you will be mailed your Warranty Card and a Customer Survey. We appreciate your feedback and encourage you to fill out the survey after you have had a chance to run your boat for several weeks. We take this input very seriously, and have implemented many of the ideas our customers have given us through this survey. You may also visit our web site at www.pleasurecraft.com.

Again, thanks for choosing PCM. We sincerely wish you happy days on the water.

INTRODUCTION - 1

5 YEAR TRANSFERABLE LIMITED WARRANTY

Pleasurecraft Marine Engine Co., through its PCM Engines Division ("PCM"), warrants its new products to be free from defects in material and workmanship under normal use and service conditions, to the first registered owner or registered user, as well as all subsequent users who, in accordance with PCM's warranty transfer policy, have received within 30 days of a sale transaction involving the product a transfer of any remaining period of coverage under this warranty. The obligation of PCM under this warranty shall be limited to the repair or replacement with new or reconditioned components, at PCM's option, of any product, or parts thereof, which have failed during the warranty period specified below and are demonstrated upon examination to have failed due to defective material and/or workmanship.

WARRANTY COVERAGE; TERM

This warranty is extended only to the first registered owner or registered user, as well as all subsequent users who, in accordance with PCM's warranty transfer policy, have received within 30 days of a sale transaction involving the product a transfer of any remaining period of coverage under this warranty, as specified below.

All components, other than those itemized below and those components that are warranted by PCM's suppliers, are warranted, solely for non-commercial use, for a period of 5 years or 500 hours of use, whichever first occurs, from the earlier of (1) the date of sale to the first registered owner or registered user, or (2) from the date the engine is first placed into service for demonstration or any other purpose prior to the sale of the engine to the first owner purchasing the engine at retail, as well as to all subsequent users who, in accordance with PCM's warranty transfer policy, have received a transfer of any remaining portion of this warranty coverage within 30 days of any subsequent sale of the product. In the case of commercial use of the product, the term of this warranty shall be the shorter of (a) a period of 6 months from the date of sale to the first registered owner or registered user, or (b) the expiration of 200 hours of use.

Components not covered under this warranty:

- (1) Water pump impellers are not covered by this warranty.
- (2) Seals, gaskets, o-rings, and other materials affected by time are not covered by this warranty if their effectiveness is reduced by an extended storage period prior to sale or use of the product.
- (3) Items such as, but not limited to, lubricants, spark plugs and other items which are normally frequently replaced as part of routine maintenance.

NO OTHER WARRANTY GIVEN

The obligations set forth in the preceding paragraphs are PCM's sole obligation and the owner's exclusive remedy. PCM makes no other express warranty. Any implied warranty of merchantability or fitness for a particular purpose that may be applicable to this product is limited in duration to the duration of this warranty. Some States do not allow limitations on how long an implied warranty lasts, so the above limitation may not apply to you.

No distributor, dealer, agent or employee of PCM is authorized to grant any other or further warranty or incur any additional warranty obligation on PCM's behalf in connection with the sale of its products. Any qualification or restriction contained herein which is prohibited by any law of mandatory application shall be deemed to be deleted from this warranty; however, such deletion shall have no effect on the remaining provisions hereof, all of which shall remain in full force and effect.

REMEDIES

The obligation of PCM set forth in the first paragraph of this warranty shall be the exclusive remedy for any breach of warranty hereunder, and any owner or user's sole remedy in the event of breach of the warranties is repair or replacement of the product or any warranted part thereof as set forth in this warranty; with this sole exception, PCM shall not be liable for any direct or indirect, incidental or consequential damages, including without limitation, any damages for property damage, loss of use or loss of profits, loss of income, inconvenience, trailering, towing, haul out, launch and/or any other in and out of water expenses, storage charges, dockage charges, expenses to deliver or pick up the product being warranted to and from the dealer, telephone expenses, lodging expenses, travel expenses, mechanic travel time and mileage, damage caused by any occurrence of an insurable nature, rental of substitute equipment of any type, removal and replacement and/or modification of any boat parts to facilitate repairs, moving of furniture, carpets, cleaning, painting, carpenter work, or re-delivery charges. Some States do not allow the exclusion or limitation of incidental or consequential damages, so the above limitation or exclusion may not apply to you.

Any owner or user hereby waives for himself/herself/itself and his/her/its successor and assigns (a) any and all claims for punitive damages, and (b) all claims of negligence or strict liability or both. In no event will PCM's liability exceed the purchase price of the product(s) which is actually paid to PCM.

OBTAINING PERFORMANCE UNDER WARRANTY

PCM's warranty registration form should be prepared by your selling dealer, executed by you and the dealer, and mailed by you to PCM within 30 days after the date of your purchase of the product. Upon receipt of the warranty registration form, PCM will issue to you a personalized owner's registration card which will be mailed directly to you. If the owner's registration card is not received within 8 weeks after the date of purchase, please write to PCM at the address set forth below.

At the time that a claim for warranty service is made, the owner's registration card should be presented to the person or entity providing warranty service. Authorized PCM dealers or distributors are entitled to be reimbursed by PCM for some or all of the expense of warranty repairs; thus, service under the terms of this warranty will be performed by an authorized PCM dealer or distributor without charge for established flat rate labor or replacement parts, other than items not covered by the warranty, such as, but not limited to, water pump impellers, seals, gaskets, o-rings and other materials affected by time if their effectiveness is reduced by an extended storage period prior to sale or use of the product, and lubricants, spark plugs and other items which are normally frequently replaced as part of routine maintenance. Charges for additional non-warranty work and/or additional dealer charges for labor relative to warranty work in excess of flat rate must be paid for by the owner.

Prior authorization in writing must be obtained from PCM for any warranty repairs over \$50.00 and in all cases where the owner fails to establish the purchase and warranty expiration dates with the owner's registration card sent upon receipt of the warranty registration form by PCM. While failure to present the owner's registration card will not prevent you from obtaining coverage hereunder, this warranty shall not be effective and, therefore, cannot be honored until the product purchase date can be confirmed by PCM. If the card is lost, communicate with PCM at the address listed below, and, for a processing fee of \$10.00, a new owner's registration card will be issued to you.

Any questions concerning service, parts or this warranty should be directed to your selling dealer. If your dealer is unable to assist or if you relocate or are travelling or need a referral to your nearest dealer contact: Pleasurecraft Marine Engine Co., P.O. Drawer 369, Little Mountain, SC 29075 ((803) 345-0050).

FAILURES EXCLUDED FROM WARRANTY

This warranty will not apply to any failure which results from accidents, sinking, fire, neglect, abuse or abnormal service or use, such as racing, towing or operation in water of insufficient depth, or to any failure resulting from improper installation, improper adjustments, repairs or improper delivery service, or to any failure resulting from the use of parts, fuels, oils or lubricants not suitable for use with the product and/or materials or parts not approved by PCM. This warranty does not apply to any engine or drive which has been modified, or altered, or repaired in such a manner as, in the opinion of PCM, to affect its stability, reliability or performance. Further, this warranty will not apply to product failure resulting from (1) use of non-recommended lubricants or fuels, (2) failure to follow maintenance or lubrication schedules, (3) failure caused or contributed to by improper or contaminated fuel, (4) failure caused by water intrusion, salt corrosion to external components, or improper installation or misapplication of the engine or drive, (5) the owner's or operator's failure to exercise due or normal care and precaution, (6) failure of components and/or assemblies that are warranted by PCM suppliers, and (7) damage resulting from the owner's or operator's failure to timely replace failed water pump impellers, seals, gaskets and o-rings.

OWNER'S RESPONSIBILITY

Performance under this warranty shall be conditioned upon the first registered owner's or registered user's compliance with the following requirements:

- (1) Owner or user shall verify that the pre-delivery service has been performed, all requested information recorded and that the selling dealer has signed the warranty registration.
- (2) Owner or user shall promptly mail the warranty registration to PCM after accepting delivery.
- (3) Owner or user shall follow the instructions in the owner's manual regarding operation, break-in, lubrication and fuel.
- (4) Owner or user shall follow or comply with the maintenance schedule, operation limits, and lay up instruction, as outlined in the owner's manual.

CHOICE OF LAW

This limited warranty shall be governed by, and construed and interpreted in accordance with, the local laws of the State of Ohio (without application of its conflicts of laws principles), except only to the extent replaced or precluded by other law of mandatory application.

GENERAL

This warranty gives you specific legal rights, and you may also have other rights which vary from State to State.

The PCM Federal/California Emissions Warranty and Federal/California Emissions Control Warranty Statement are separate documents included in the owner's manual. Any questions concerning the Emissions Warranty can be obtained by calling (803) 345-0050.

PCM's policy is one of continued improvement of its products, and PCM hereby reserves the right to improve and change the design and production of any of its products without assuming any obligation to modify products previously manufactured and/or sold.

PLEASURECRAFT MARINE ENGINE CO.

FEDERAL/CALIFORNIA EMISSION CONTROL WARRANTY STATEMENT YOUR WARRANTY RIGHTS AND OBLIGATIONS

The United States Environmental Protection Agency (“USEPA”), the California Air Resources Board (“CARB”) and Pleasurecraft Marine Engine Co., through its PCM Engines Division (“PCM”), are pleased to explain the emission control system warranty on your inboard marine engine manufactured after January 1, 2008 for CARB and after January 1, 2011 for USEPA. Nationally, new inboard engines must be designed, built and equipped to meet USEPA’s and CARB’s emissions and stringent anti-smog standards. PCM must warrant the emission control system on your inboard engine for the periods of time listed below provided there has been no abuse, neglect or improper maintenance of your inboard engine.

Your emission control system may include parts such as the carburetor or fuel injection system, the ignition system, and catalytic converter. Also included may be hoses, belts, connectors and other emission-related assemblies. Where a warrantable condition exists, PCM will repair your inboard engine at no cost to you, including diagnosis, parts and labor.

MANUFACTURER’S WARRANTY COVERAGE:

Select emission control parts of inboard marine engines (manufactured after January 1, 2008 for CARB and after January 1, 2011 for USEPA) are warranted for 3 years or 480 hours of use, whichever first occurs.

However, warranty coverage based on the hourly period is only permitted for engines that are equipped with appropriate hour meters as defined in California Code of Regulations Title 13, Chapter 9, Article 4.7 §2441(a) (13) or the equivalent. If any emission-related part on your engine is defective under warranty, the part will be repaired or replaced by PCM.

OWNER’S WARRANTY RESPONSIBILITIES:

- As the inboard engine owner, you are responsible for the performance of the required maintenance listed in your owner’s manual. PCM recommends that you retain all receipts covering maintenance on your inboard engine, but PCM cannot deny warranty solely for the lack of receipts or your failure to ensure the performance of all scheduled maintenance.
- As the inboard engine owner, you should however be aware that PCM may deny you warranty coverage if your inboard engine or a part has failed due to abuse, neglect, improper maintenance or unapproved modifications.
- You are responsible for presenting your inboard engine to an authorized PCM dealer as soon as a problem exists. The warranty repairs will be completed in a reasonable amount of time, generally within 30 days.

If you have any questions regarding your warranty rights and responsibilities, you should contact PCM at (803) 345-0050.

INTRODUCTION - 1

PLEASURECRAFT MARINE ENGINE CO. GENERAL EMISSIONS WARRANTY COVERAGE

(for engines manufactured after January 1, 2008 for CARB and after January 1, 2011 for USEPA)

1. Pleasurecraft Marine Engine Co., through its PCM Engines Division ("PCM"), warrants to the first owner purchasing at retail, and all subsequent owners, of every PCM inboard marine engine manufactured after January 1, 2008 for CARB and after January 1, 2011 for EPA, that the emissions control devices on PCM inboard marine engines are free from defects in materials and workmanship when manufactured and will remain so for a period of 3 years or 480 hours of use, whichever first occurs, from the earlier of the date of sale to the first owner purchasing the engine at retail or the date the engine is first placed into service for demonstration or any other purpose prior to sale to the first owner purchasing the engine at retail.
2. Pursuant to the Code of Federal Regulations 40 CFR Part 1045 and Part 1068 and California Code of Regulations Title 13, Chapter 9, Article 4.7§ 2445.1, PCM warrants that each PCM engine is designed, built and equipped to conform with all applicable regulations adopted by USEPA and CARB pursuant to its authority in Chapters 1 and 2, Part 5, Division 26 of the California Health and Safety Code, and is free from defects in materials and workmanship that cause the failure of a warranted part to be identical in all material respects to that part as described in PCM's application for certification.
3. Any part covered under this warranty that is not scheduled for replacement as required maintenance, in the written instructions to be found within the PCM owners/operators manual, is warranted for the period of 3 years or 480 hours of use, whichever first occurs. If the part fails during the period of warranty coverage, PCM will repair or replace the defective part at any PCM warranty station. The repair or replacement will be performed at no charge to the owner. Any such part repaired or replaced under this warranty will be warranted for the remainder of the period of 3 years or 480 hours of use, whichever first occurs.
4. Any part covered under this warranty that is scheduled only for regular inspection in the written instructions to be found within the PCM owners/operators manual, is warranted for the period of 3 years or 480 hours of use, whichever first occurs. If the part fails during the period of warranty coverage, PCM will repair or replace the defective part at any PCM warranty station. The repair or replacement will be performed at no charge to the owner. Any such part repaired or replaced under this warranty will be warranted for the remainder of the period of 3 years or 480 hours of use, whichever first occurs.
5. Any part covered under this warranty that is scheduled for replacement as required maintenance in the written instructions to be found within the PCM owners/operators manual will be warranted for the period of time before the first scheduled replacement date for that part. If the part fails before the first scheduled replacement, PCM will repair or replace the defective part at any PCM warranty station. The repair or replacement will be performed at no charge to the owner. Any such part repaired or replaced under this warranty will be warranted for the remainder of the period prior to the first scheduled replacement date for the part.
6. Replacement of any part under this warranty with a PCM-supplied part, will not shorten nor extend the warranty period(s) stated in paragraphs 1 through 4 above.
7. The engine owner will not be charged for diagnostic labor that is directly associated with diagnosis of a defective, emission-related warranted part, provided that such diagnostic work is performed at a PCM warranty station.

8. To insure prompt repair under this warranty, PCM will maintain a supply of warranted parts sufficient to meet the expected demand for such parts. Any replacement part may be used in the performance of any warranty maintenance or repairs and will be provided by PCM without charge to the owner.

9. Parts covered under this warranty are:

Fuel Metering System

- A. Fuel Injectors
- B. Fuel Pressure Regulator
- C. Manifold Absolute Pressure Sensor
- D. Throttle Position Sensor
- E. Throttle Body - Port Fuel Injection Models
- F. Coolant Temperature Sensor
- G. Intake Valves
- H. Oxygen Sensors

Air Induction System

- A. Intake Manifold
- B. Air Filter (Flame Arrestor)

Ignition System

- A. Spark Plugs
- B. Electronic Ignition System
- C. Ignition Coil and/or Control Module
- D. Ignition Wires

Lubrication System

- A. Oil Pump and Internal Parts

Positive Crankcase Ventilation (PVC) System

- A. PCV Valve
- B. Oil Filler Cap

Exhaust System

- A. Exhaust Manifold(s)
- B. Exhaust Riser(s)
- C. Exhaust Valves
- D. Catalytic Converters

Miscellaneous Items Used on Above Systems

- A. Hoses, clamps, fittings, tubing, sealing gaskets or devices and mounting hardware
- B. Electronic Controls
- C. Electronic Control Module
- D. Pulleys, belts and idlers

10. Exclusions: The repair or replacement of any warranted part otherwise eligible for coverage under this warranty may be excluded from such warranty coverage if PCM demonstrates that the engine and/or part has been abused, neglected, or improperly maintained, and that such abuse, neglect, or improper maintenance was the direct cause of the need for repair or replacement of the part.

11. PCM original equipment parts are "identical in all material respects to that part as described in the engine manufacturer's application for certification". The use of any replacement parts not supplied by PCM may not meet this requirement and will be grounds for disallowing a claim made under this warranty. PCM will not be liable under this warranty or provide warranty coverage for product failures caused by parts other than PCM original equipment parts.

12. If you have any questions regarding your warranty rights and responsibilities, or the location of PCM warranty stations near you, you should contact PCM at (803) 345-0050.

**This Page Was
Intentionally
Left Blank**

SAFETY INFORMATION

“Safety Warnings” and additional information or instructions are used to alert the installer/operator of possible safety hazards in performing certain service or maintenance procedures incorrectly or carelessly. DANGERS and WARNINGS are accompanied by the international HAZARD symbol: 

These “Safety Warnings” alone cannot eliminate the hazards that they signal. Strict compliance with these warning instructions while performing service and maintenance procedures, plus “common sense” operation, are major accident prevention measures.

REPLACEMENT PARTS



DANGER

Electrical, ignition and fuel system components are designed and manufactured to comply with U.S. Coast Guard rules and regulations to minimize the possibility of fire or explosion hazard.

Use of replacement parts (i.e. automotive, after-market, etc.) in the electrical, ignition and fuel systems, which are not U.S. Coast Guard approved, could cause a fire or explosion hazard and should be avoided.

Always request that genuine PCM Engines replacement parts be used in any repairs or maintenance being performed on your engine(s).

SAFETY WARNINGS



DANGER

Signals serious damage, failure or breakdown of equipment; severe injury or high probability of death to the user if proper precautions are not taken. This signal word is applied in extreme situations



WARNING

Indicates a potential hazard which could result in personal injury.



CAUTION

Indicates a hazard which could result in damage to equipment.

IMPORTANT: or **IMPORTANT:** Used to provide information to perform a procedure more easily.

WARRANTY NOTICE: Indicates a possible warranty exclusion.

BOATING RESPONSIBILITIES - 2

CARBON MONOXIDE HAZARD



DANGER

Carbon Monoxide (CO) is a colorless, odorless and tasteless gas. You cannot see it, smell it or taste it. Prolonged exposure to carbon monoxide can lead to unconsciousness, brain damage or death!

Carbon monoxide is produced when anything that contains carbon, such as gasoline, natural gas, oil, propane, coal or wood is burned. Carbon monoxide is commonly found in the exhaust of internal combustion engines (boat power plants, generators, etc.). In addition, open flame devices like cooking ranges, heaters and charcoal grills also produce carbon monoxide.

Carbon monoxide accumulation, in and around boats is affected by vessel geometry; overall vessel design; closeness to other structures; wind direction; boat speed; and many other variables. In no way can this section cover all of the possible variables. Do not rely on this section as the exclusive listing of measures to prevent the accumulation of carbon monoxide.

Consult your boat operators manual for detailed information on the inspection and/or maintenance of the exhaust system for your particular application. If an inspection reveals possible leaks, DO NOT operate your engine(s) until it can be serviced by a qualified technician.

Proper and adequate air circulation, around and throughout the boat, is absolutely necessary to aid in the prevention of carbon monoxide build-up. If you have any questions or concerns regarding the operation of your boat and carbon monoxide hazards, DO NOT operate your engines until you have contacted your boat manufacturer.

To find out more about making boating safer, including how you can prevent carbon monoxide poisoning on recreational boats, contact:

National Marine Manufacturers Association

200 East Randolph Drive
Suite 5100
Chicago, IL 60601-6528
www.nmma.org
312-946-6200

United States Coast Guard

Office of Boating Safety
CG Headquarters G-OPB-3
2100 Second Street SW
Washington, DC 20593
www.uscgboating.org
202-267-0984

American Boat & Yacht Council, Inc.

3069 Solomon's Island Road
Edgewater, MD 21037-1416
www.abyc.com
410-956-1050

SAFE BOATING SUGGESTIONS

The nation's waterways are becoming increasingly crowded and, in order to enjoy them safely, the operator should acquaint himself/herself with safe boating practices. Boating safely and seamanship courses are offered by the following national and state organizations:

- Power Squadrons
- Coast Guard Auxiliary
- Red Cross
- State, provincial or local agencies in charge of water safety enforcement

PCM Engines highly recommends that all power boat operators attend one of these courses. To help locate a course being offered near you, contact Boat U.S. Foundation's toll-free national boating safety hotline, 1-800-336-BOAT, and in Virginia, 1-800-245-BOAT.

WATER WISDOM

The following are suggestions for safe operation of your boat to ensure the safety of yourself and your passengers:

- Know your boat's loading and operating limitations. **DO NOT OVERLOAD!**
- Make periodic checks of safety equipment onboard.
- Do not consume alcoholic beverages or take illegal drugs when operating a boat. Some state laws apply to boats as well as motor vehicles.
- File a "float plan." Let someone know your destination and your expected time of return.
- Monitor the weather. Know the signs of weather change and avoid severe weather and rough seas whenever possible.
- Follow the "Rules of the Road" when boating. Always be on the alert and watch out for "the other guy."
- Plan and chart your course. Be aware of, and avoid, hazardous areas.
- Be sure your boat is equipped with the required safety equipment. Check with the Coast Guard and local government agencies as to the regulations and restrictions in your area. Contact your local Coast Guard Auxiliary and take advantage of their seasonal boat inspections.

The following is a list of suggested safety equipment and spare parts which may be useful in case of an emergency:

- Approved personal flotation devices (life jackets); one for each person on board.
- Approved throwable personal flotation device for man-overboard protection.
- Approved fire extinguishers.
- Signal devices: flares, spotlight, signal flag and horn or whistle.
- PCM Engines' "Onboard Kit," plus spare fuses, bulbs, batteries, etc. Tools necessary for minor repairs.
- Spare propeller.
- Anchor and anchor line.
- First aid kit and first aid book.
- Ship-to-shore radio, compass and chart of the area in which you are traveling.
- Manual bilge pump and spare drain plugs.
- Waterproof storage containers.

OPERATION AND MAINTENANCE

It is the owner's/operator's responsibility to perform all safety checks before operating his/her boat. All lubrication and maintenance schedules must be adhered to assure optimum performance and dependability from your PCM engine. When service and maintenance are required, return to your authorized PCM Premier Engine Dealer.

BOATING RESPONSIBILITIES - 2

RULES OF THE ROAD

Channel Buoy Guide

The color of the paint is the only characteristic which has the same meaning on all buoys. Red buoys always indicate the starboard side of the channel from seaward. (Red Right Returning)

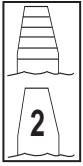

1. **Nun Buoy:** This buoy indicates the starboard side of the channel when returning from sea. It is conical shape, the color red and indicates even numbers. A nun buoy with red and green horizontal bands (top band red), and not numbered, indicates an obstruction. The principal channel is to the left of the buoy when returning from sea.

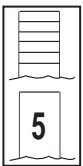

2. **Can Buoy:** This buoy indicates the port side of the channel when returning from sea. It is cylindrical shape, the color green and indicates odd numbers. A can buoy with green and red horizontal bands (top band green), and not numbered, indicates an obstruction. The principal channel is to the right of the buoy when returning from sea.



3. **Lighted Buoy (RED):** This buoy has a flashing red light. It indicates the starboard side of the channel when returning from sea.



4. **Lighted Buoy (GREEN):** This buoy has a quick flashing green light. It indicates the port side of the channel when returning from sea. The quick flashing light indicates special caution required.

Small Craft Winds up to 38 MPH	Gale Winds 38 - 54 MPH	Storm Winds over 55 MPH	Hurricane Winds over 63 MPH

Storm Warning Signals - Pennants (by day) Lights (by night)

Boat Capacity

- Load only to manufacturer's specifications.
- Distribute load evenly; keep it low.
- Passengers should only ride on the parts of the boat that are designed for that purpose.
- If water is rough, carry fewer passengers.

Observe the Rules of the Road

PORT (Left) - Leaving the harbor with green buoys to your right.

STARBOARD (Right) - Entering the harbor with red buoys to your right.

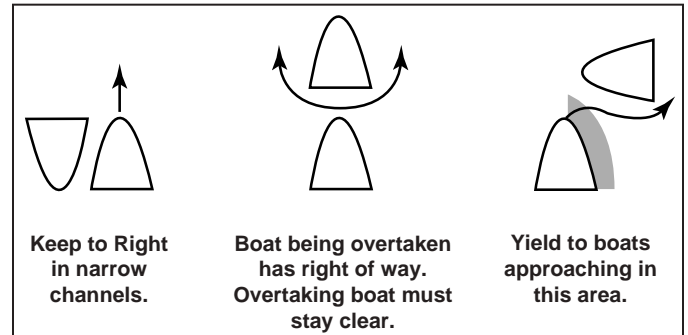

Know Your Horn Signals

- 1 Short Blast = Passing you on my port side.
- 2 Short Blasts = Passing you on my starboard side.
- 3 Short Blasts = I am going astern.
- 5 Short Blasts = Danger.

Always refer to the latest U.S. Coast Guard Navigation Rules CG-169

Keep An Alert Lookout For:

Bad weather, Swimmers, Other boats, Water skiers, Fisherman, Divers and/or any other obstructions.

Keep Your Wake Under Control, particularly upon entering or leaving harbor areas. You are responsible for wake damage to other vessels and/or property.

Do Not Fool With Fuel

1/2 pint of gasoline = 15 sticks of dynamite

1. During fueling, moor boat properly; remove all passengers.
2. Keep all doors, hatches and ports closed.
3. Shut down all electronic gear; extinguish galley fires, pilot lights and smoking materials.
4. Do not overload tanks.
5. Keep filling nozzles in contact with the fill pipe to prevent sparks.
6. Secure the fill cap tightly; wipe away any spillage.
7. Ventilate all components for a minimum of five minutes before starting engines.
8. Keep fuel lines and bilges clean.

ENGINE IDENTIFICATION

When ordering service parts or obtaining information, always give the engine model and the serial number. This information can be found on the following decal.

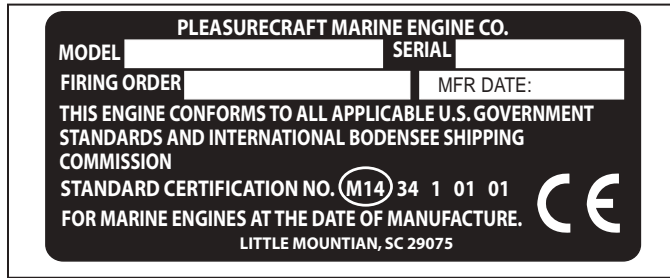

Figure 3-1 Engine Identification Decal

1. ENGINE SPECIFICATION DECAL - The engine specification decal is located on the inboard side of the right exhaust manifold.
2. ENGINE IDENTIFICATION DECAL - The engine identification decals are located in two locations on the engine. One decal is located on the outboard side of the left exhaust manifold and the second decal is located on the thermostat housing pipe on the front of the engine.
3. TRANSMISSION IDENTIFICATION PLATE - The transmission identification plate is located on the rear face of the transmission housing.
4. VDRIVE IDENTIFICATION PLATE - The Vdrive identification plate is located on the rear face of the Vdrive housing.

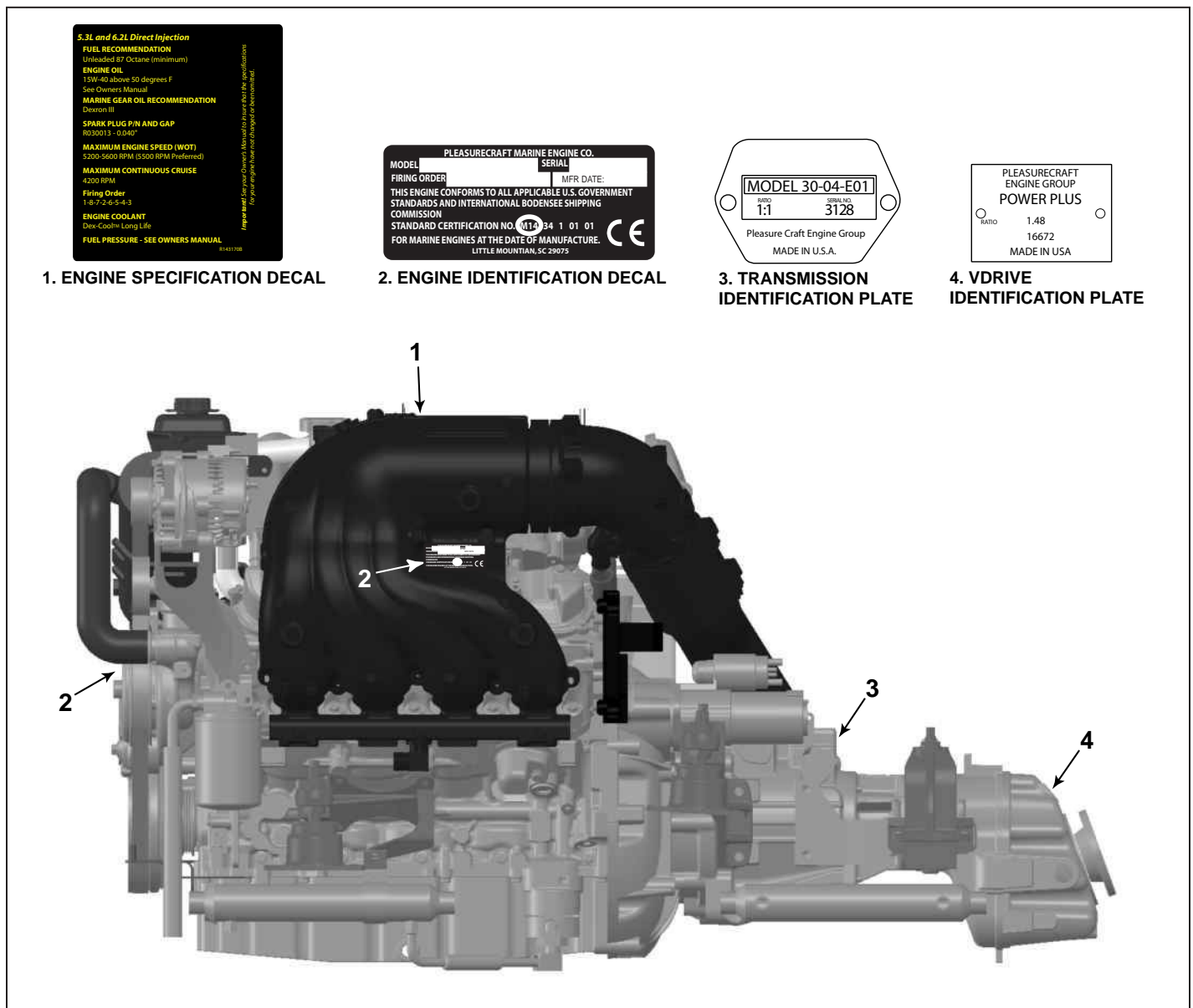

Figure 3-2 Identification Tag Locations

ENGINE IDENTIFICATION - 3

PCM

ENGINE MODEL IDENTIFICATION / ADVISORY

MODEL 0 2 - 535 VC - 0 1 SERIAL 565000

1st - 2nd Space: **MANUFACTURING CODE**

3rd - 5th Space: **ENGINE CODE**
535 = 5.3L Direct Injection
625 = 6.2L Direct Injection

6th - 8th Space: **DRIVE CONFIGURATION**
blank - Direct Drive
V - V-Drive
C - Catanium Clean Emissions System (CES)
S - Salt Water Edition

9th - 10th Space: **SPECIFICATION CODE**

SERIAL NUMBER I.D.

1st DIGIT INDICATES DECADE ENGINE WAS MANUFACTURED (3 = 1990, 4 = 2000, 5 = 2010)
2nd DIGIT INDICATES CALENDAR YEAR ENGINE WAS MANUFACTURED.

OWNER IDENTIFICATION AND REGISTRATION INFORMATION

We suggest that you record the following information for quick reference when ordering parts or requesting service or warranty.

Engine Model Number:	
Serial Number:	
Trans. Model Number:	
Serial Number:	
VDrive Model Number:	
Serial Number:	
Boat Make:	
Boat Model:	
Hull Serial Number:	
Propeller Size:	
Ignition Key Number:	

ELECTRONIC FUEL INJECTION INFORMATION - 4

ELECTRONIC FUEL INJECTION SYSTEM

The PCM Engines covered in this manual are equipped with an Electronic Fuel Injection (EFI) system, which allows precise control of fuel and spark delivery. The fuel system components of the EFI system are:

- The electric fuel pumps
- The throttle body assembly
- The fuel injectors

The fuel injection system is controlled by an Electronic Control Module (ECM). The ECM constantly monitors information from various sensors on the engine, and electronically processes the information, in order to control ignition timing and fuel delivery for optimum performance and fuel economy. The ECM incorporates an engine overspeed protection, calibrated to a specific RPM, to prevent engine damage from over-revving.

The sensors that the ECM monitors are:

- Engine Coolant Temperature (ECT) Sensor
- Throttle Position (TP) Sensor
- Manifold Absolute Pressure (MAP) Sensor
- Knock Sensor (KS) System
- Crankshaft Positioning (CKP) Sensor
- Camshaft Positioning (CMP) Sensor
- Intake Air Temperature (IAT) Sensor
- Throttle Control Position (TCP) Sensor
- Pre-Catalyst Wide Band Oxygen (O₂) Sensors
- Post-Catalyst Oxygen (O₂) Sensors
- Exhaust Manifold Riser Temp (ERWT) Sensors

If, for any reason, one or more of these sensors or associated wiring malfunctions, the ECM's built-in self-diagnostic system sets a trouble code and turns on the "MIL" Malfunction Indicator Lamp to alert the operator of a malfunction.

In most cases, when the "MIL" is on, the engine(s) may lose some performance and/or efficiency, but remain running adequately. Also, the light may go out or become intermittent, but a trouble code will be logged for future diagnosis. (See Engine Alarm System - page 16)

In any case, the operator must obtain service by an authorized PCM Premier dealer to determine the exact cause of the malfunction.

ENGINE ALARM SYSTEM

The PCM engine electronic system is programmed to control the engine alarm system. Your Engine Alarm System may utilize up to three (3) alarm circuits to warn you of a potential problem with your engine.

The Malfunction Indicator Lamp (MIL) is used for notification of any emissions-related fault. This is an amber indicator lamp, that may be labeled 'Service Soon' or with the ISO icon, to warn the operator of possible engine problems.

The Check Gauges Lamp (CGL) is used for notification of any non-emissions-related fault. This is a red indicator lamp to warn the operator of possible engine problems such as low oil pressure or an over temperature condition.

The Buzzer is an audible notification to the operator, that may be used in conjunction with the MIL and/or CGL.

The alarm circuit has a "self" checking feature programmed into the system. This feature will light the "MIL" and "CGL" lamps, and also sound the buzzer for two short pulses upon initial start-up of the engine.

NOTE: If, during Key ON, engine OFF, either the MIL or CGL lamps are flashing, this indicates that a stored trouble code or engine fault is recorded in the ECM. Refer to your dealer for proper diagnosis.

If the "MIL" or "CGL" lights and the alarm sounds during operation, observe the instrument panel readings for the possible source of the malfunction, such as low oil pressure or excessive engine temperature readings.

Other conditions that may sound the warning buzzer are a transmission over-temperature warning (if equipped), exhaust manifold water over-temperature warning, and for an electronic throttle malfunction.

IMPORTANT: A failure involving the Electronic Throttle may result in *idle only* operation of the engine. The

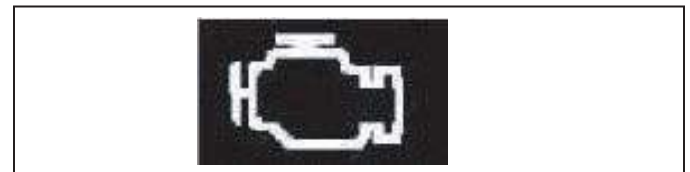

ISO Icon

operator must obtain service by an authorized PCM Premier dealer to determine the exact cause of this malfunction as soon as possible.

In most cases, when the "MIL" or "CGL" lights are on, the engine may lose some performance and/or efficiency, but remain running adequately. Also, the lights may go out or become intermittent, but a trouble code will be logged for future diagnosis.

In any case, the operator must obtain service by an authorized PCM Premier dealer to determine the exact cause of the malfunction.

NOTICE: Some boat builders may install their own alarm system. It is recommended that the boat owner check with his or her boat dealer for an explanation of the particular alarm system upon initial delivery.

OPERATING INSTRUCTIONS - 5

INSTRUMENTATION

Boat manufacturers install many different types of instrumentation on boats. Become familiar with the instrumentation on your boat and be aware of abnormal operating conditions. The following is a brief explanation of typical instrumentation found on most boats:

1. Tachometer - indicates the engine RPM (revolutions per minute)
2. Water Temperature Gauge - indicates the engine coolant temperature
3. Oil Pressure Gauge - indicates the engine oil pressure
4. Voltmeter - indicates the battery voltage and charging system voltage
5. Hour Meter - indicates the engine operating time
6. Fuel Level Gauge - indicates the fuel tank level
7. Malfunction Indicator Lamp (MIL) or Check Gauges Lamp - indicates a problem with the engine control system

Notice: Many boat manufacturers are using Controller Area Network (CAN) based instrumentation. This instrumentation is driven by a two-wire network from the engine. Refer to your boat manufacturers Owners manual for the type of instrumentation being used with your application.

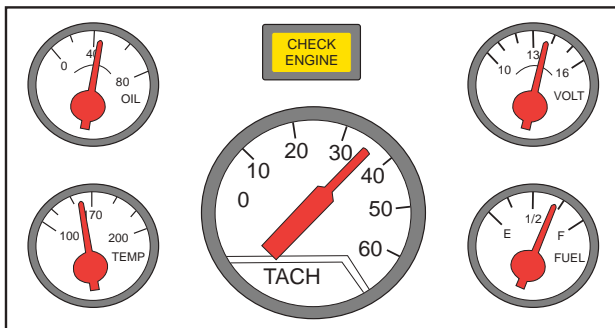

Figure 5-1 Typical Instrument Panel



Figure 5-1A Example Warning Lamp Cluster

STARTING ENGINE (FUEL INJECTED ENGINES)



WARNING

Before starting engine, ventilate the engine compartment by operating the bilge blower for a minimum of five minutes to remove any gas fumes from the engine compartment. If the boat is not equipped with a blower, open the engine compartment hatches to ventilate and leave open while starting engine.

IMPORTANT: Do not start the engine without water being supplied to the sea water pick-up pump or sea-water pump impeller will be damaged, and subsequent overheating damage to the engine may result.

IMPORTANT: The following items should be checked before starting the engine, and each time the boat is operated:

- Fuel system for any signs of leakage
- Operation of remote controls and steering
- Engine and transmission oil levels
- Fuel tank levels
- Exhaust system for leaks and tightness of the clamps
- Battery connections and water level in battery cells
- Accessory drive belt(s)
- Cooling system for leaks. If equipped with fresh-water cooling, check coolant level in recovery bottle. Check for signs of water leaks at the exhaust manifolds, risers and elbows (Figure 5-2). If the water is leaking externally, it is possible that the water is also leaking internally. This could result in internal engine damage. It is very important to service these maintenance items as soon as a problem is indicated. After performing the initial safety checks, proceed as follows to start the engine:

1. Turn the battery switch ON (if equipped).
2. Open the fuel valve.
3. Open the seacock.
4. Place the remote control in Neutral position. The transmission is equipped with a neutral safety switch, which will not allow the starter motor to operate unless the transmission is in neutral.

- Do not pump or open the throttle when starting the engine (Figure 5-3). The ECM will automatically regulate the fuel and control desired idle speed.

PCM has introduced a product enhancement feature on all PCM Multipoint Fuel Injection Products. Your engine may be equipped with the engine auto-crank feature. This feature allows the engine to automatically crank, or turn over, when commanded. Once the operator has turned the key to the START position on a key switch, or depressed the START button on a touchpad, the engine will automatically turn over and start. The engine will turn over until the engine starts, or a maximum of 5 seconds. The key switch or stop button can always be utilized in order to cease the engine from cranking and/or starting.

Important: In the event that the engine must be turned over WITHOUT automatically cranking or starting (i.e. bumping the engine to #1 position or performing a compression check) a remote starter button MUST be used, connected directly to the starter solenoid and the ignition system disabled.

- Turn the ignition key to the start position. When the engine starts, release the key.

NOTICE: Engine idle speed is controlled by the ECM and is based on the operating temperature of the engine. Upon initial start-up, engine RPM will be slightly higher and will automatically decrease as the engine operating temperature increases.

- In the event the engine becomes flooded,** ensure the Neutral Lockout is engaged and move the throttle lever to a 100% open position (Figure 5-3). At this throttle position, the ECM will command the injectors to deliver no fuel during engine cranking. When the engine starts, return the throttle lever back to the idle position.

NOTICE: Single lever throttle/shift handles use different mechanisms to achieve Neutral Lockout or throttle only operation. Some require you to push in on a button while moving the handle forward, others require the button to be pulled out. Refer to your boat owners manual for complete instructions on throttle/shift lever operation.

IMPORTANT: If the engine fails to start within 20-30 seconds, turn the ignition key to the OFF position and allow 2 minutes for the starter motor to cool off before attempting to restart the engine.

NOTICE: If engine still fails to start, contact your PCM Engines Dealer for service.

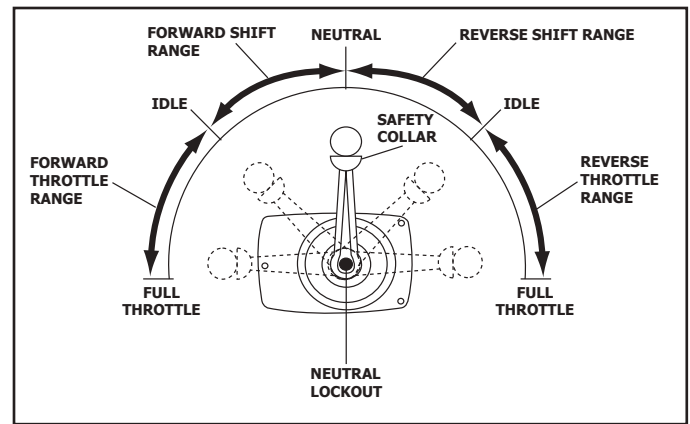

Figure 5-3 Typical Throttle / Shift Position Settings



WARNING

The machinery space must be closed anytime the engine is running to prevent injury to you or others on board. Never operate the engine with the engine machinery space open while someone is in the machinery space, either closed or open. Never open the machinery space unless the engine is shut off and the engines rotating parts are stationary. Rotating machinery can cause injury and even death if an accident should occur. Extreme care must be exercised if a problem exists that requires operation of the engine with the machinery space open. **IT IS RECOMMENDED THAT UNCOVERED ENGINE OPERATION BE ATTEMPTED BY TRAINED AND QUALIFIED SERVICE PERSONNEL ONLY.**

- Check engine oil pressure immediately after the engine starts. If oil pressure is not within specifications (see Engine Specifications), immediately stop the engine and determine the cause.
- Check voltmeter for proper charging system operation.
- Check the engine and transmission for fuel, oil, water and exhaust leaks.
- Allow the engine to reach normal operating temperature. Check the temperature gauge to ensure the engine is operating within the normal temperature range. If the temperature is abnormally high, stop the engine immediately and determine the cause.

OPERATING INSTRUCTIONS - 5

ELECTRONIC SPEED CONTROL (IF EQUIPPED)

Refer to your Boat Manufacturers Owners/Operation manual for specific operation and troubleshooting information for your speed control system.

SHIFTING TRANSMISSION



CAUTION

Never shift the transmission into or out of gear unless the throttle is at the idle position. Shifting the transmission above 1000 RPM can severely damage the boat, transmission and engine.

1. Set the throttle lever at the idle position.
2. Pull up on the Safety Collar and slowly push the throttle/shift handle into the Forward gear Idle position.

Throttle may be increased/decreased as required in the Forward Throttle Range.

3. Pull up on the Safety Collar and slowly pull the throttle/shift handle back into the Reverse gear Idle position.

Throttle may be increased/decreased as required in the Reverse Throttle Range.

4. Move the transmission lever to the **center detent** position to shift into Neutral.

FREEZING TEMPERATURE OPERATION

If the possibility of freezing exists, the cooling system must be protected after the engine is shut off to prevent freeze damage to the engine. Refer to OUT-OF-SEASON STORAGE for draining instructions.

OPERATION IN HIGH DEBRIS AREAS

If the boat is to be operated in high debris areas, a sea strainer should be installed in the water inlet hose to prevent debris from entering the cooling system. The strainer used must be of sufficient size to allow an adequate supply of water for cooling the engine. A minimum of 30 gallons per minute (114 liters per minute) flow rate is required.

CONDITIONS AFFECTING OPERATION - 6

WEIGHT DISTRIBUTION

Positioning of the weight (gear and passengers) inside the boat has the following effects on handling:

- Trimming the bow up or shifting weight to the stern (rear).
 - Normally used for cruising (running) with a choppy wave condition (following sea) for running at full speed.
 - Will generally increase speed and engine RPM.
 - Will cause the bow to bounce in rough water.
 - In extreme, may cause the boat to porpoise.
 - When coming off plane, it increases the chances of following wave splashing into the stern of the boat.
- Positioning the weight to the bow (front).
 - Normally used for cruising (running) against a choppy wave condition, acceleration onto plane and operating at slow planing speeds.
 - Will improve rough water ride and handling.
 - In extreme, may cause the boat to bow steer (veer back and forth with little control).

BOAT BOTTOM

To ensure maximum engine performance, fuel economy and boat speed, the bottom of your boat must be kept clean and free of marine growth and barnacles. Marine vegetation may accumulate when the boat is docked and should be removed before operation. If the boat is docked for long periods of time, the water inlets may become clogged with growth and will cause the engine to overheat.

In most areas, it is advisable to coat the boat bottom with antifouling paint to prevent the build-up of marine growth. Contact your dealer for advice on these requirements in your area.

PROPELLER SELECTION

Best all-around performance and maximum engine life is achieved when the engine is propped to run near the top of (but within) the recommended full throttle RPM range with a normal load. See ENGINE SPECIFICATIONS for rated full throttle RPM for your model engine.

Generally, gross weight (total weight of the entire boat, including full fuel and water, optional equipment, passengers and other miscellaneous gear) is one of the major factors and should be one of the primary considerations when selecting a propeller. Other factors to take into consideration are as follows:

- Warmer weather and higher humidity will cause an RPM loss.
- Operating the boat in a higher elevation will cause an RPM loss.
- Operating the boat with an increased load will cause an RPM loss (additional equipment, passengers, etc.).

If full throttle RPM is above or below the recommended range as stated in ENGINE SPECIFICATIONS, the propeller must be changed to prevent loss of performance. A one-inch change in the pitch of a given propeller will generally change engine RPM by 150 to 250 RPM.

ENGINE RPM CHART

Model	Minimum Full Load	Preferred	Maximum
5.3L DI	5300	5500	5600
6.2L DI	5300	5500	5600



CAUTION

Prolonged WOT operation will shorten the life of your engine and could cause premature engine failure. See NORMAL CRUISING SPEEDS in SPECIFICATIONS. Problems caused by prolonged WOT operation are considered abuse and are not covered under the PCM Warranty.

IMPORTANT NOTICE: *Your new PCM engine incorporates an RPM "MAX GOVERNOR" in order to prevent the engine from over-revving. Operation above the Maximum RPM listed, in the chart above, is not recommended. If your engine is operating above the maximum RPM listed, a higher pitched propeller would be required to lower the engine maximum RPM to the Preferred RPM listed in the chart above.*

ENGINE BREAK-IN PERIOD - 7



WARNING

Use this procedure **ONLY** when conditions are such that it can be done in complete safety.

The break-in period of your engine is the first 25 hours of operation. Proper engine break-in is essential to achieve maximum performance, longevity and minimum oil consumption. During the break-in period, the following operation guidelines must be adhered to:

- After the engine is thoroughly warmed up, and the boat is underway, open the throttle to wide open throttle until maximum RPM is reached. **DO NOT EXCEED MAXIMUM RPM.** (RPM should cease climbing after 10 to 20 seconds).



CAUTION

DO NOT operate at full throttle in neutral at any time, or at sustained full throttle during the first 5 hours of operation. Thereafter, use sustained wide open throttle in the event of an emergency.

- Reduce the throttle to 2800 - 3000 RPM, and cruise at or below this speed for 1/2 hour. Reduce the speed to idle. Go to wide open throttle until maximum RPM is reached and operate for approximately 1 minute. Reduce throttle to 2800-3000 RPM and operate for a few minutes. (Bringing the engine speed from idle to wide open throttle will load the engine and assist in seating the piston rings). This cycle should be repeated from time to time during the first 5 hours of operation, but wide open throttle should not be sustained for more than 30 seconds.
- During the remaining 20 hours of break in period, the engines can be run at cruise speeds that are approximately 75-80% of the wide open throttle RPM, occasionally varying the cruise speed by 100 RPM.
- During the early part of the break in period, the correct propeller selection can be confirmed. (With a normal load aboard, the engine's RPM should reach, but not exceed, the maximum RPM as listed in the specifications section).
- During the break in, all gauges should be watched carefully, and the speed should be reduced if abnormal readings become evident.



CAUTION

DO NOT attempt to break in any engine by prolong idling, or running at the dock.

The engine oil level should be checked often and oil added when necessary. It must be understood that every internal combustion engine will use a certain amount of oil during operation to act as a lubricating and cooling agent, especially during the break-in period. Oil consumption should decrease and become stabilized after approximately 100 hours of operation.

Somewhere before 25 hours of your break-in period, contact your dealer and have the recommended 25-hour inspection done.

NOTICE: PCM Engines assumes no responsibility for the costs related to the 25-hour inspection. This is the owner's responsibility.

25-HOUR ENGINE INSPECTION - 8

After the first 25 hours of operation, it is recommended that the engine be given an inspection. Your boat dealer or a PCM Premier servicing dealer should be contacted to perform the necessary checks and adjustments to ensure the proper engine performance. The following maintenance should be performed:

- Change the engine oil and filter. This engine starts out with break-in oil and should be run in the engine for at least the first 5 hours of operation. Any time after 5 hours, but NO MORE than 25 hours, the engine oil and filter must be changed. See ENGINE OIL RECOMMENDATIONS later in this publication.
- Replace the primary fuel pre-filter
- Check the engine alignment.
- Inspect the accessory drive belt(s) and check the tension.
- Check all the fluid levels.
- Check the throttle and the shift cable adjustments and check for freedom of movement.
- Cooling System - Inspect all the hoses for leaks, damage and deterioration. Check all the hose clamps for adequate tightness.
- Models with Thermostatically-Controlled Exhaust Cooling System - Inspect exhaust cooling system thermostat and housing inlet. Clean as necessary.
- Exhaust System - Inspect the entire exhaust system for leaks, damage and deterioration. Check all the hose clamps for adequate tightness.
- Battery - Check the electrolyte level and specific gravity. Inspect the case for damage. Check the battery cables and connections.
- Engine Assembly - Check for loose, missing or damaged parts. Pay close attention to engine mounts, starter and alternator mounting fasteners.

NOTICE: PCM Engines assumes no responsibility for the costs related to the 25-hour inspection. This is the owner's responsibility.

FUEL REQUIREMENTS - 9

GASOLINE REQUIREMENTS



CAUTION

Fire and Explosion Hazard - Gasoline is extremely flammable and highly explosive, and, if ignited, can cause serious bodily injury or death. Careful inspection of the entire fuel system including, but not limited to, fuel tanks, fuel lines, fuel filters and all fittings is mandatory, especially after periods of storage. Replace any component that shows signs of leakage, corrosion, deterioration, swelling, hardening or softening.

WARRANTY NOTICE: Damage caused to the engine through the use of improper gasoline, low-quality or gasoline with an octane rating below the minimum requirements listed below, is considered misuse of the engine. Such damage is not covered by the PCM Marine Engines warranty.

The ignition timing set by the factory requires the use of a high-quality lead-free regular gasoline with the following minimum octane specification.

Pump Octane Number (R+M/2) (PUMP) - 87

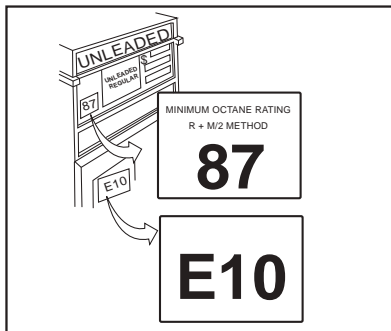

Figure 9-1 Fuel Requirements

NOTICE: These engines have been calibrated to operate on 87 octane fuel. PCM's engine control module incorporates Adaptive Learn Technology to ensure optimum engine performance is obtained when using fuel rated higher than 87 octane. Use of fuels lower than 87 octane will result in reduced performance, could cause engine damage and should be avoided.

If a slight pinging is heard during acceleration and the proper octane fuel is being used, it is considered normal. If a constant, heavy knock occurs, the engine should be evaluated by a PCM Marine Engines Premier service technician.

ATTENTION: For optimal performance, these applications should run premium 93 octane fuel.

GASOLINE CONTAINING ALCOHOL

The implementation of ethanol-based fuel is spreading rapidly throughout the United States. As such, PCM Engines provides the following information regarding the use of this fuel.

This information addresses the use of ethanol fuels in PCM ENGINES ONLY. It does not address the use of ethanol fuels in vessel related components such as boat gas tanks, boat fuel lines, etc.

Ethanol blended fuel rated E10 or less is acceptable to use. Fuels rated higher than E10 SHOULD NOT BE USED. Ethanol fuels rated higher than E10 could potentially damage the engine and/or present an unsafe boating condition. Damage to the engine resulting from the use of ethanol fuel rated higher than E10 IS NOT covered by the warranty.



CAUTION

Do Not use any gasoline that contains METHANOL. This fuel is very corrosive and will create unsafe operating conditions. Serious damage will result from the continued use of fuel containing METHANOL. Any resulting engine damage will not be covered by the warranty.

If ethanol blended fuel rated E10 or less is used, or if the presence of alcohol is uncertain, more frequent inspections and service of the complete fuel system are required. Any sign of fuel leakage or deterioration must be repaired immediately before further engine operation.

It is important to note that ethanol blended fuel will act as a solvent and will attract and hold moisture. **Without proper fuel stabilization and fuel filtration, ethanol blended fuel may cause the following:**

- Excessive moisture (water) may cause lean operation to include hard starting and operating difficulties such as, vapor lock, low speed stalling, and shortened fuel shelf life.
- Acting as a solvent, ethanol blended fuel may cause gum, sediment, sludge, and other particles to be loosened and carried through the fuel system to the engine.

Fuel system or engine damage caused by contamination from water, foreign particles, sludge, or gums entering or forming in the fuel system is not covered by the PCM Limited Warranty.

Fuel Stabilizer Recommendations for Ethanol Blend Fuel

The use of a commercially available fuel stabilizer, such as STA-BIL®, is recommended at each fill-up or when storing ethanol-blended fuel for more than **2 weeks**.

ENGINE OIL RECOMMENDATIONS

Use of Supplemental Additives

Engine oils meeting PCM Engines' recommendations already contain a balanced additive treatment. The use of supplemental additives which are added to the engine oil by the customer are unnecessary and may be harmful. PCM Engines does not review, approve or recommend such products.

Synthetic Oils

Synthetic engine oils may be used in PCM Marine Engines. Synthetic oils must meet the Engine Oil Requirements for Classification and Viscosity listed below. The use of synthetic oil **does not** permit the extension of oil change intervals.

Engine Oil Requirements

The following chart shows the recommended oil viscosity for various ambient temperature ranges:

Engine Oil Requirements

Prevailing Ambient Temperature	Recommended A.P.I. Classification & Viscosity
Above 50°F	SAE 15W-40 "GF-4/SM"
Below 50°F	SAE 5W-30 "GF-4/SM"

IMPORTANT: The use of oils which contain "solid" additives, non-detergent oils or low quality oils specifically are not recommended.

WARRANTY NOTICE: PCM Engines reserves the right to refuse warranty on part(s) and/or engine(s) damaged by using improper fuels and engine oils.

Oil Change Intervals (Common)

Crankcase oil and oil filter change - Recommended intervals:

- Initial oil change - 1st 60 days or 5-25 hours of operation, whichever occurs first
- Regular oil changes - Every 50 hours of operation or 120 days, whichever occurs first
- Heavy Duty High RPM / High Load Use - Every 30 hours of operation or 120 days, whichever occurs first

NOTE: Never over-fill the engine with oil. Engines over-filled with oil can cause engine damage.

TRANSMISSION AND "V"-DRIVE OIL REQUIREMENTS

Transmission and "V" Drive	Recommended A.P.I. Classification and Viscosity
PCM Transmissions	Dexron III Automatic Transmission Fluid (ATF) or equivalent
PCM V-Drive Transmissions	Mobiltrans SHC 50 Synthetic Transmission Lubricant PCM P/N - R190250

IMPORTANT: Dexron III should be used in all applications requiring Dexron III. Dexron VI MUST NOT be mixed with Dexron III when servicing. Damage caused by using incorrect fluid is not covered under warranty.

ENGINE MAINTENANCE - 11

ENGINE MAINTENANCE

Refer to the MAINTENANCE SCHEDULE for a complete listing of required maintenance and the frequency at which it should be performed. While some procedures may be performed by the owner/operator, PCM Engines strongly recommends that all engine service and maintenance be performed by an authorized PCM Engines Premier Dealer. Before performing any maintenance or repair procedure not covered in this manual, it is strongly recommended that a PCM Engines repair manual be purchased and read thoroughly.

CHECKING FLUID LEVELS

Engine Crankcase Oil



CAUTION

Do Not overfill engine crankcase with oil. Excessive oil can lead to premature engine component failure and/or loss of performance.

IMPORTANT: *The engine oil level must be checked while the boat is in its normal, level, at rest position on the water. Excessive wave action side to side or fore and aft may cause you to obtain erroneous readings. If the oil level is being checked while the boat is on a trailer, ensure the trailer is on level ground, then adjust the trailer so the boat is at its normal, at rest position. Excess water in the bilge and, if equipped, ballast systems must be purged when checking the engine oil level, otherwise erroneous readings may be obtained.*

1. Stop the engine, if running. Allow approximately 5 minutes for the oil to drain back into the oil pan.
2. Remove the dipstick, wipe it clean, and reinstall it until it is within two (2") inches of being fully seated. Slowly move the dipstick up and down approximately one-half (1/2") several times; then fully seat the dipstick into the dipstick tube.
3. In order to obtain an accurate reading, wait two minutes for the oil to stabilize on the dipstick. Remove the dipstick and observe the oil level. The oil level must be between the "FULL" and "ADD" marks. If the oil level is below the "ADD" mark, add specified oil to bring the level up to, but not over, the "FULL" mark on the dipstick. If the oil level is above the "FULL" mark on the dipstick, remove the excess oil. (Figure 11-1)

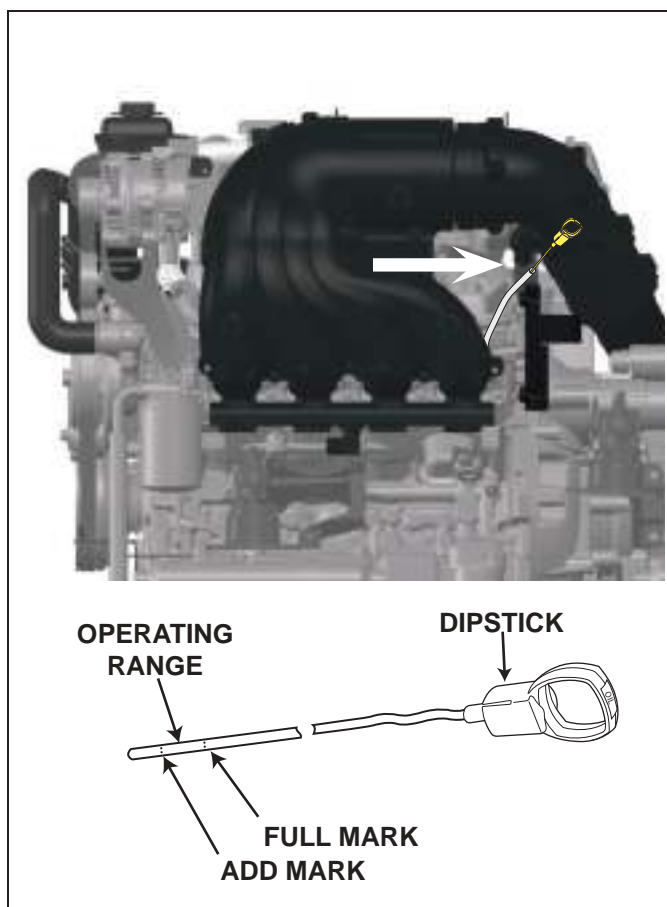

Figure 11-1 Engine Oil Dipstick



WARNING

The machinery space must be closed anytime the engine is running to prevent injury to you or others on board. Never operate the engine with the engine machinery space open while someone is in the machinery space, either closed or open. Never open the machinery space unless the engine is shut off and the engines rotating parts are stationary. Rotating machinery can cause injury and even death if an accident should occur. Extreme care must be exercised if a problem exists that requires operation of the engine with the machinery space open. ***IT IS RECOMMENDED THAT UNCOVERED ENGINE OPERATION BE ATTEMPTED BY TRAINED AND QUALIFIED SERVICE PERSONNEL ONLY.***

Transmission Fluid



CAUTION

PCM Engines uses marine transmissions supplied by several manufacturers. The maintenance requirements can be different between these manufacturers. It is important that you refer to the operation and maintenance manual supplied by the transmission manufacturer before you attempt to perform maintenance on your own. If no maintenance manual is available, PCM Engines recommends that you contact your dealer service department for any required maintenance or service instructions.

PCM 80 Series 1.23:1 Transmissions

1. The fluid level must be checked in one of the following conditions:
 - A. Engine/Transmission is cold;
 - B. Engine/Transmission has been shut off for at least 2 minutes to allow fluid to drain back.
2. Remove the dipstick by turning the T-handle counterclockwise. Wipe the dipstick off using a clean cloth.
3. Re-insert the dipstick to the threads (**DO NOT screw the dipstick in**) and remove. Observe the fluid level.
4. The fluid level should be at the "FULL" mark. If low, add the specified fluid in small increments through the dipstick hole in the transmission. Repeat the checking procedures until the fluid level is at the "FULL" mark.
5. Replace the dipstick and tighten securely.

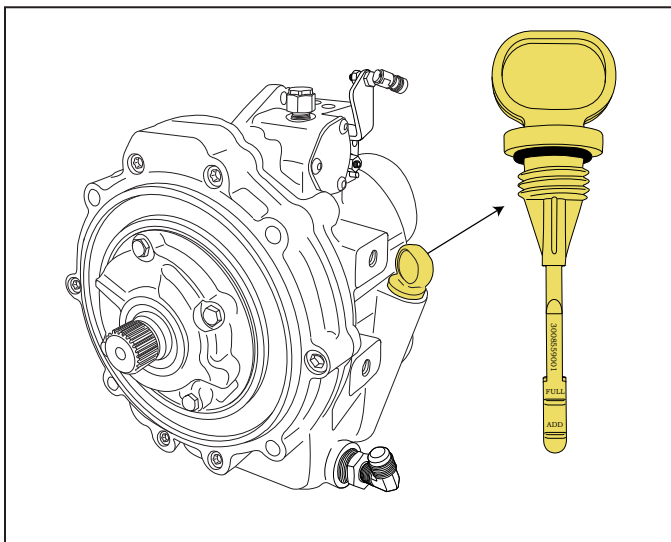

Figure 11-2 80 Series 1.23:1 Transmission Dipstick and Location



WARNING

Do not attempt to remove the transmission dipstick while the engine is running. Hot transmission fluid could be sprayed from the dipstick hole.

PCM 80 Series 1:1 Transmissions

(Dipstick Handle has a "hole" as a Dipstick Identifier)

NOTE: If the Dipstick Handle does not contain the "hole" identifier, consult PCM Customer Service for the proper Checking Procedure.

1. The fluid level must be checked in one of the following conditions:
 - A. Engine/Transmission is cold;
 - B. Engine/Transmission has been shut off for at least 2 minutes to allow fluid to drain back.
2. Remove the dipstick by turning the T-handle counterclockwise. Wipe the dipstick off using a clean cloth.
3. Re-insert the dipstick to the threads (**DO NOT screw the dipstick in**) and remove. Observe the fluid level.
4. The fluid level should be at the "FULL" mark. If low, add the specified fluid in small increments through the dipstick hole in the transmission. Repeat the checking procedures until the fluid level is at the "FULL" mark.
5. Replace the dipstick and tighten securely.

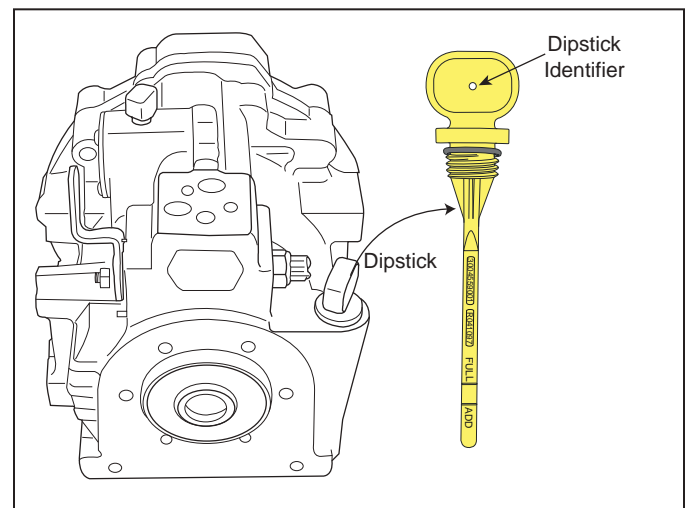

Figure 11-3 80 Series 1:1 Transmission Dipstick and Location

ENGINE MAINTENANCE - 11

PCM Power-Plus V-Drive Transmission



WARNING

Do not attempt to remove the transmission drain/fill plug while the engine is running or while the transmission is hot. Hot transmission fluid could be sprayed from the hole.

All PCM Power-Plus "V" Drive transmissions are designed to be 'Maintenance Free'. Inspect fluid level after the first 25 hours of use and annually thereafter. Fluid should only be changed if evidence of contamination is present. Use Mobiltrans SHC 50 synthetic transmission lubricant. PCM P/N: R190250.

1. Remove the drain/fill/dipstick plug from the transmission. Wipe the dipstick clean and insert into transmission - Do Not Screw the dipstick into the hole. Remove and observe the fluid level.
2. The fluid level should be between the FULL mark and the end of the dipstick. **If a plug is used, fluid level should be to the bottom of the threaded hole.** If low, add the specified fluid through the threaded hole to the proper level.

NOTE: The transmission fluid is a very high viscosity, to make adding fluid easier, remove both fill plugs.

3. Replace the drain/fill/dipstick plug(s) and tighten securely.

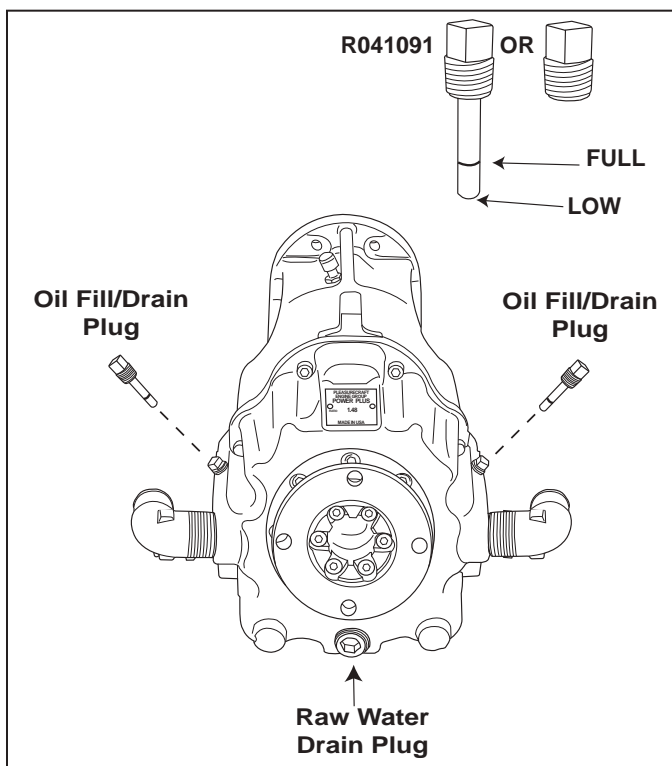

Figure 11-4 Transmission Service Location

ELECTRICAL SYSTEM RELAY AND FUSE BLOCK

MAIN PANEL FUSE

PCM engines are equipped with a 40 Amp PANEL fuse which provides electrical overload protection for the boat's instrumentation wiring and components. Should an electrical overload occur, the PANEL fuse will open and prevent electrical current flow.

When this fuse opens, the cause for the high current draw must be found and corrected. Check the battery and alternator connections and all other harness connectors between the boat and the engine main harness. Check for loose or disconnected lead wires and shorted circuits. Replace the PANEL fuse and resume operation. If the cause of the overload cannot be found, consult an authorized PCM Engines dealer to make necessary repairs.

ELECTRICAL SYSTEM FUSES

PCM engines utilize fuses to protect critical engine components and devices. The fuel pump, ECM, ignition components, fuel injectors, starter and diagnostic devices are protected by fuses. The fuse block is mounted on a bracket near the rear of the engine.

BOAT'S IGNITION FUSE

If the engine will not crank when the ignition key is turned to the START position, first check that the shift lever is in the neutral position and the safety lanyard (if equipped) is attached properly. If none of the Fuse Block fuses are open, check for a blown boat ignition fuse. The boat's ignition fuse may be located on the instrument panel, the fuse holder block or as part of the helm's instrument wiring harness. Check the wiring diagrams supplied from the boat manufacturer for the exact location.

ELECTRICAL SYSTEM WIRING AND CONNECTORS

The electrical system wiring and connectors should be checked periodically for loose or dirty connections and damaged wiring. If electrical components or wiring show signs of corrosion, deterioration or damage, consult an authorized PCM Engines dealer to make necessary repairs.

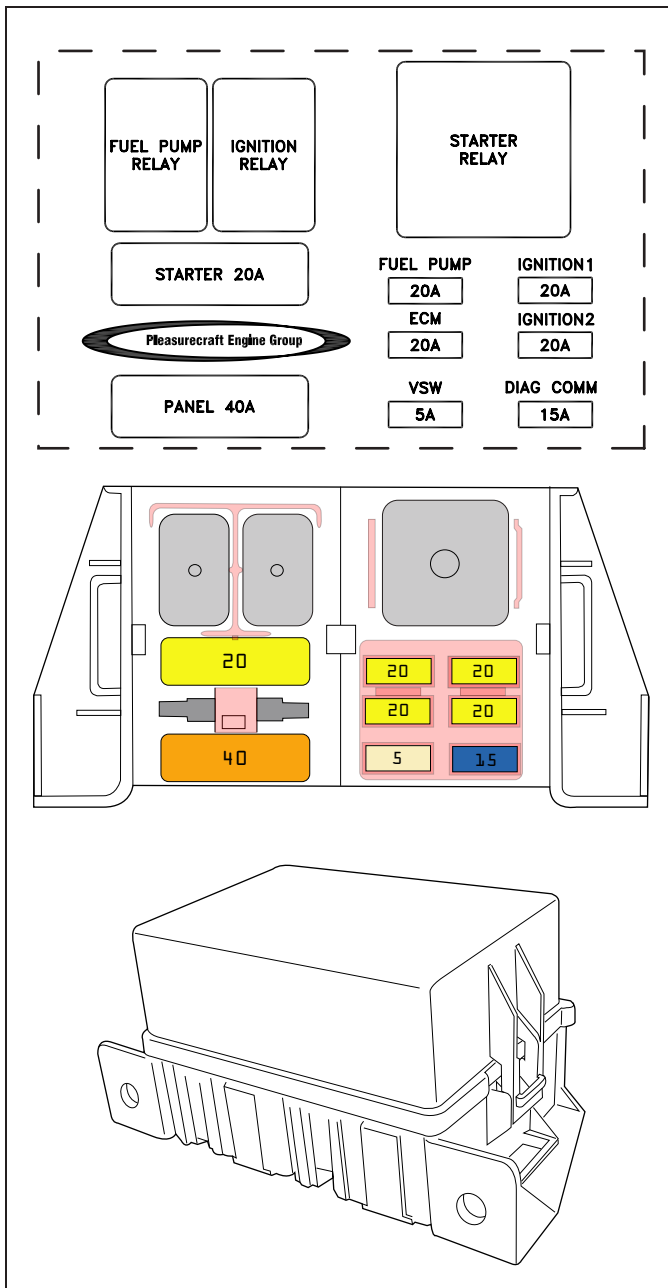

Figure 11-7 (Typical) Electrical System Relay and Fuse Block

BATTERY



WARNING

Battery electrolyte is a corrosive acid and should be handled with care. If electrolyte is spilled or splashed on any part of the body, IMMEDIATELY flush the exposed area with liberal amounts of water and obtain medical aid as soon as possible. Safety glasses and rubber gloves are recommended when handling batteries or filling with electrolyte.



WARNING

Hydrogen gases that escape from the battery when charging are highly explosive. Do not use jumper cables and a booster battery to start the engine. Do not recharge a weak battery in the boat. Remove the battery from the boat and recharge in a well ventilated area away from fuel vapors, sparks and open flames.

Follow maintenance instructions and warnings as supplied by the battery manufacturer. If this information is not available, follow these guidelines for the proper battery care.

- Do not operate the engine with an open in the battery circuit, as this may cause damage to the alternator. Make sure that all connections are clean and secure.
- When removing the battery cables, always remove the negative (-) cable first, and then remove the positive (+) cable. When installing battery cables, install the positive (+) cable first, then install the negative (-) cable.
- Periodically check the battery for signs of corrosion, frayed battery leads or cracked case. Repair or replace as necessary.
- Periodically check the electrolyte level. Add distilled water to bring up to the proper levels.

IMPORTANT: Your engine is designed to work with the standard electronics installed in your boat. If you add other electrical components or accessories, you could change the way the fuel injection controls your engine or the overall electrical system functions. Before adding electrical equipment, consult your dealer. If you don't, your engine may not perform properly.



CAUTION

Add-on equipment may adversely affect the alternator output or overload the electrical system. Any damage caused as a result will not be covered by, and may void, your warranty.

ENGINE MAINTENANCE - 11

COOLING SYSTEM SACRIFICIAL ANODES

Located in the raw water side of the cooling system are sacrificial anodes which are marked by a decal. To check, remove the anode and visually check the condition of the rod. The length of the anode rod when new is approximately 1.5 inches. If more than one half of the anode is gone, replace with a new sacrificial anode.

Different geographic locations and water make-up can result in either high or low sacrificial requirements. A high rate of sacrificial anode consumption should also alert the owner to a possibility of an improperly wired boat accessory, which would require complete checking by qualified service personnel.

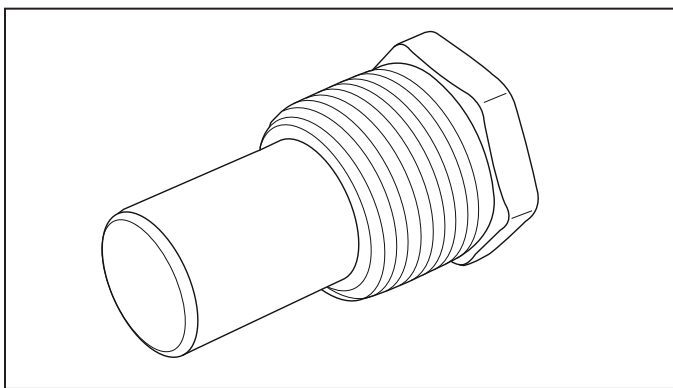

Figure 11-8 Sacrificial Anode

SACRIFICIAL ANODE LOCATIONS

PCM Raw Water Applications

- One anode is in the rear of each exhaust manifold.

PCM Fresh Water Applications

- One anode is in the rear of each exhaust manifold.
- One anode is in the heat exchanger raw water drain location.
- One anode is in the rear of the Vdrive Housing for a drain.
- One anode is in each of the exhaust corners for raw water drain.

CHECKING COOLANT LEVEL



WARNING

Do not remove cooling system filler cap when the engine is hot. Allow the engine to cool and then remove the pressure cap slowly, allowing the pressure to vent. Hot coolant, under pressure, may discharge violently and cause severe burns.

Degas Bottle

The “see-through” degas bottle is connected to the heat exchanger by a small hose. The degas bottle collects coolant that expands with rising temperature, and would otherwise overflow from the system. Coolant level should be at or slightly above the “ADD” mark on the bottle when the system is cold. Coolant should be added ONLY to the bottle when the system cools. Add specified coolant as required.

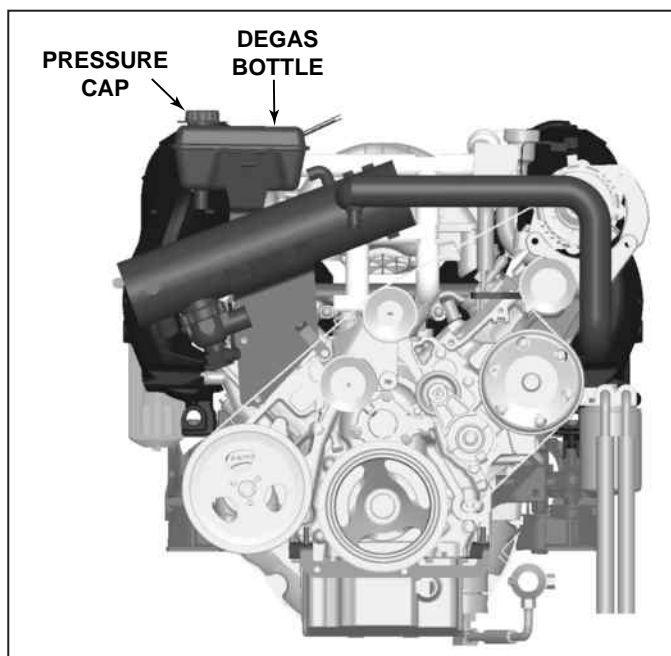

Figure 11-9 Checking Coolant Level

TESTING COOLANT FOR ALKALINITY

It is recommended that the coolant in the fresh-water section be tested each year for alkalinity. Coolant that is not alkaline has lost the effectiveness of its rust inhibitors, which can lead to internal corrosion and cooling system problems. It is recommended to replace standard ethylene glycol coolant in the system every two years or long life coolant, Dex-Cool™, every five years to prevent a build-up of harmful chemicals within the fresh-water system.



WARNING

Do not remove cooling system filler cap when the engine is hot. Allow the engine to cool and then remove the pressure cap slowly, allowing the pressure to vent. Hot coolant, under pressure, may discharge violently and cause severe burns.

1. Obtain red litmus paper from a local supplier (drugstore, laboratory, etc.).
2. Remove the pressure cap from the coolant degas bottle and insert one end of the litmus paper into the coolant.
3. If red litmus paper turns blue, coolant is alkaline and does not need to be replaced. If the litmus paper remains red, the coolant is not alkaline and must be replaced.

FLUSHING COOLING SYSTEM - SEA-WATER SECTION

To prevent silt and/or salt build-up in the cooling system (fresh or raw-water cooled), flush the sea-water section of the cooling system with fresh water at specified intervals. Close seacock (if applicable) before removing inlet hose.



CAUTION

Do not operate the engine without sufficient amount of water being supplied to the sea-water pump. The sea-water pump impeller may be damaged and subsequent overheating damage may result.



CAUTION

Do not run the engine above 1500 RPM when flushing. Suction created by the sea-water pump may collapse the flushing hose, causing the engine to overheat. Watch the temperature gauge while flushing to ensure the engine does not overheat.

DRAINING FRESH-WATER PORTION OF THE COOLING SYSTEM

NOTICE: To protect the environment, dispose of coolant properly. Check your local restrictions for proper disposal instructions of removed coolant.

NOTICE: In order to drain the raw-water portion of the systems, refer to WATER DRAIN DIAGRAMS section of this manual for proper locations.

Remove the following drain plugs/hoses in order to drain the coolant from the fresh-water portion of the cooling system.

5.3L / 6.2L DI CES Partial Full-System

- A. Drain plug from heat exchanger.
- B. Remove large hose from the engine block water circulating pump.
- C. Drain plugs from each side of the cylinder block.

NOTE: After the system has drained completely, coat drain plugs with PerfectSeal (or equivalent) and reinstall in proper locations. Reinstall hose(s) and tighten clamps securely as required.

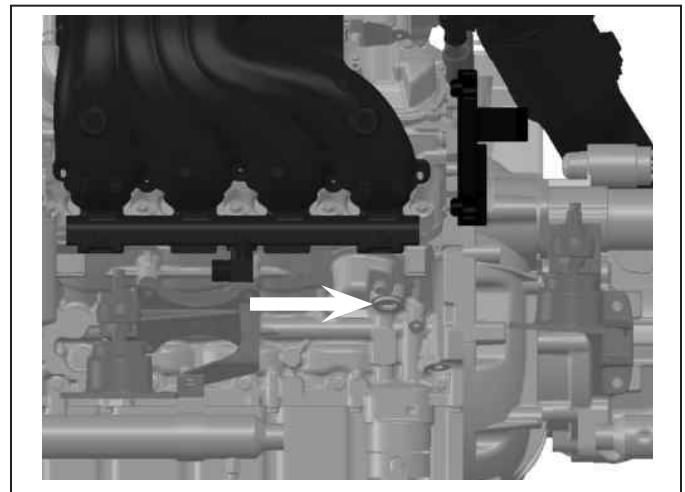

Figure 11-10 Left Side Engine Block Drain Plug

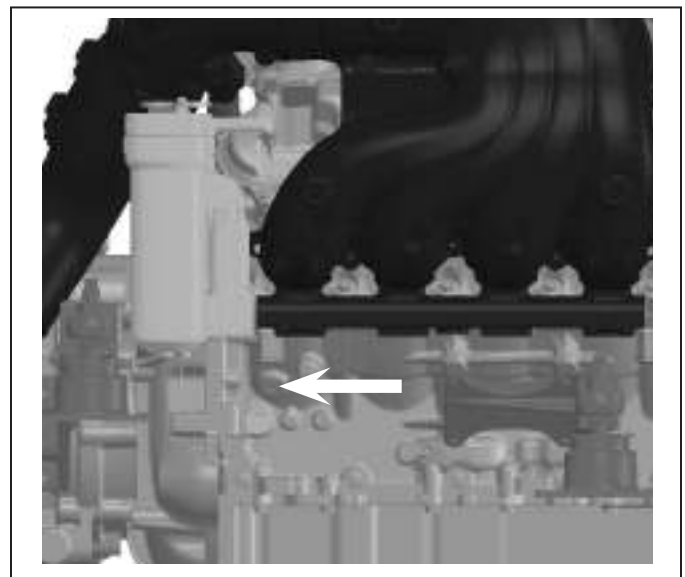

Figure 11-11 Right Side Engine Block Drain Plug

ENGINE MAINTENANCE - 11

INSPECT and CLEAN EXHAUST COOLING SYSTEM THERMOSTATS - Partial Fresh System

There is a thermostat housing on the outlet side of each exhaust manifold. Remove each raw water exhaust thermostat housing and inspect. Clean as required. This thermostat must be inspected and cleaned at the first 25 hour inspection. The thermostat must be inspected every 50 hours or once a year thereafter.

IMPORTANT: Thermostat housing **MUST** be assembled and tightened as shown, in the vertical position. Failure to do so may cause the thermostat to improperly seat and result in a leak.

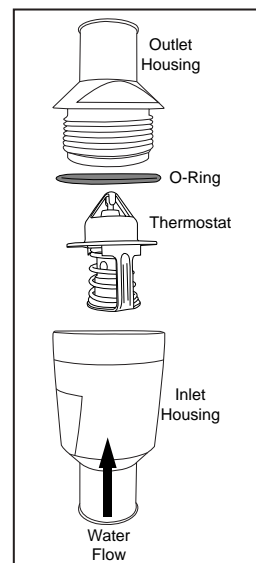

Figure 11-12 Exhaust Cooling System Thermostat Housing - Partial Fresh System

CLEANING SEA-WATER SECTION OF HEAT EXCHANGER - PARTIAL FRESH-WATER COOLED MODELS ONLY

The sea-water section of the heat exchanger should be cleaned whenever there is a noticeable decrease in cooling efficiency. You may use the following procedure for cleaning, or, if the build-up of scale and mineral deposits is heavy, it is recommended that the heat exchanger be removed and taken to a repair facility to be boiled out (such as a radiator repair facility).

1. Remove the bolts securing the heat exchanger end plates. Remove the end plates and gaskets.
2. Clean the water passages in the heat exchanger by inserting a suitable-size wire brush into each passage. Use compressed air to blow out loose particles.
3. Clean the gasket surfaces on the end plates and the heat exchanger. Apply PerfectSeal to both sides of the new gaskets. Install the end plates and the new gaskets onto the heat exchanger. Install the bolts and tighten securely.
4. Start the engine and inspect for leaks.

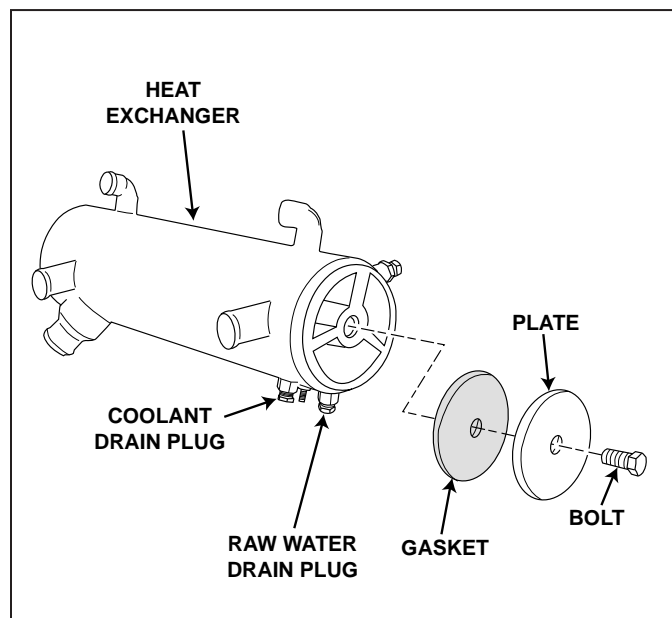

Figure 11-13 Heat Exchanger and End Plate Removal (Typical)

FUEL SYSTEM DESCRIPTION



WARNING

This fuel system can operate under extreme fuel pressures. Pressures can exceed 2000 psi in the fuel rail. Fuel system repairs should be performed only by trained and qualified technicians.



WARNING

Extreme caution must be exercised when servicing the fuel system and/or replacing fuel filter. Gasoline is extremely flammable and highly explosive under certain conditions. Be sure the ignition key is off and do not smoke or allow open flame in the area while servicing. Wipe up any spilled fuel immediately.



WARNING

Accumulation of water and other fuel contaminants may form corrosive compounds that can damage the fuel filter, and result in fuel leakage. Ethanol blended fuel may increase this risk. For this reason, annual replacement of the fuel filter, at a minimum, is required to avoid risk of explosion or fire.



WARNING

Extreme caution must be exercised when servicing the fuel system. The fuel system operates under high pressure. Use caution when removing or replacing components, as residual pressure may be present.



WARNING

Make sure that there are no fuel leaks before closing the engine hatch.



WARNING

Visually inspect unit for fuel leaks before operating the engine. If fuel leaks are present, DO NOT operate the engine, contact your service center immediately.

Fuel Control Cell (FCC) Fuel System

The Fuel Control Cell (FCC) eliminates vapor lock and air ingestion caused by fuel tank slosh, and provides the necessary filtration and water separation.

The FCC system incorporates two (2) fuel pumps to provide an uninterrupted flow of fuel to your PCM marine engine. Fuel is fed into the FCC bowl by a low-pressure, high-volume electric fuel pump. This pump flows fuel at a volume much greater than the fuel flow rate required of the high-pressure pump and engine demands. The high-pressure pump, mounted inside the FCC bowl, provides the necessary fuel pressure and volume to maintain proper engine performance. The FCC constantly has an ample supply of fuel to meet the idle, cruise and acceleration fuel requirements of the engine.

The fuel pressure regulator may be located on the fuel rail or inside the FCC bowl, controls the fuel pressure and maintains a constant pressure across the fuel delivery system. Excess fuel, not used by the engine, returns to the FCC bowl.

The fuel delivered to the engine by the FCC is filtered by a filter and water separator element, which surrounds the high pressure pump inside the FCC bowl.

As indicated above, fuel enters the FCC bowl from two (2) locations, the low-pressure pump (initial input) and the fuel pressure regulator (unused, recirculating fuel). Fuel exits the FCC bowl at two (2) locations, the high-pressure output to the fuel injection system and all excess fuel in the FCC bowl is routed back to the tank via the return line.

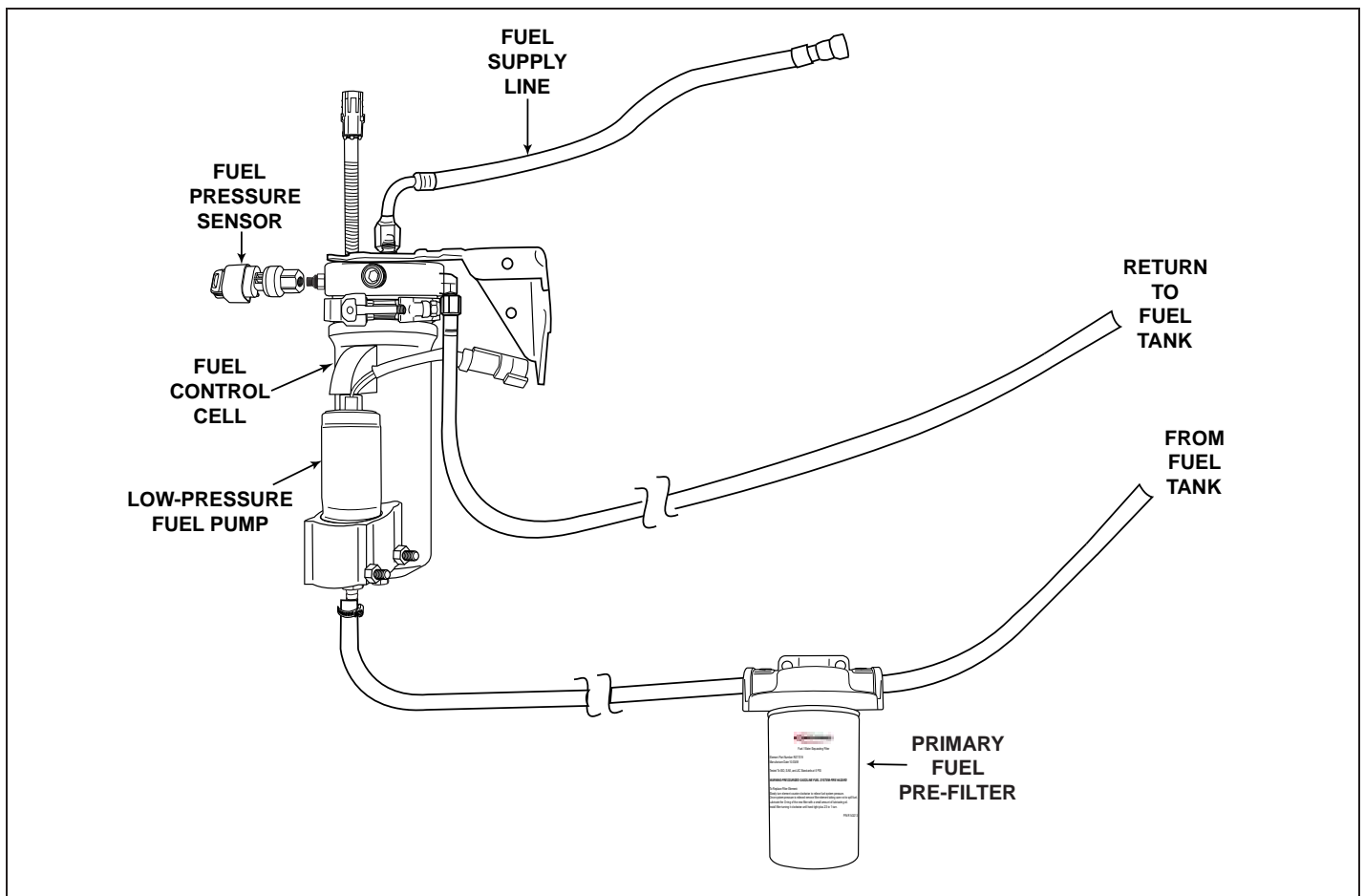

Figure 11-14 Fuel Control Cell (FCC) Fuel System (Typical)

Servicing the FCC

The frequency of draining the water or replacing the filter element is determined by the contamination level of the fuel. Replace the filter element at least once a year, or when a loss of power is noticed (whichever occurs first).



WARNING

Improper use, installation or servicing may cause an explosion or fire resulting in bodily injury, or death. This unit should only be serviced by a qualified technician. Read and follow all instructions before proceeding. Run the engine and check for fuel leaks after installation, element replacement or draining the bowl. **DO NOT** remove the FCC bowl unless servicing the filter element, otherwise contamination or bowl O-ring swelling may result.

FCC Fuel Filter (FCC Clamp-on Canister)



WARNING

Extreme caution must be exercised when servicing the fuel system. The fuel system operates under high pressure. Use caution when removing or replacing components, as residual pressure may be present.

Draining the FCC Bowl, ENGINE OFF

1. Disconnect the two-wire electrical connectors from the FCC and the Low Pressure Fuel Pump (LPFP).
2. Remove the 7/16" plug, and drain the bowl contents into an approved container.

CAUTION: Both fuel and water will drain from the FCC bowl.

3. Apply pipe sealant, suitable for use with gasoline, to the threads of the 7/16" plug.
4. Tighten the 7/16" plug.
5. Reconnect the two-wire electrical connectors to the FCC and LPFP.
6. Cycle the ignition key several times to run the electric fuel pumps and fill the FCC bowl with fuel. Inspect the drain plug area for leaks.



WARNING

Residual fuel will leak from the pump and the supply line. Elevate and plug the supply line to minimize fuel leakage. Capture/clean-up spilled fuel as required. Dispose of shop towels in an approved container.

Correct any leaks prior to operating the engine.

7. Start the engine and inspect for fuel leaks. Correct any leaks prior to operating the engine any further.

Filter Element Replacement, ENGINE OFF

FCC SERVICE KIT#: RP080026

1. Disconnect the two-wire electrical connectors from the FCC and the Low Pressure Fuel Pump (LPFP).
2. Disconnect the fuel supply line from the LPFP.
3. Remove the 7/16" plug, and drain the bowl contents into an approved container.

CAUTION: Both fuel and water will drain from the FCC bowl.

4. Remove the canister retaining clamp.
5. Slide the canister downward over the suspended filter element. It may be necessary to pull the unit to one side in order to remove.
6. Remove the fuel filter element from the suspended pump by gripping the fuel pump with one hand, and pulling the filter element downward with the other hand.
7. Visually inspect all internal components, i.e. hoses, wires, etc.

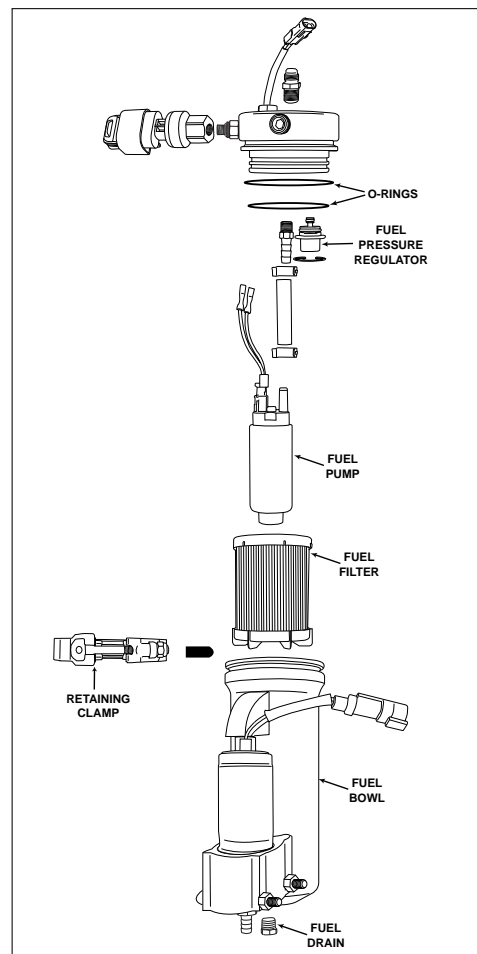

Figure 11-15 Fuel Control Cell (FCC) - Clamp-on Canister (Typical)

8. Push on new filter element (part number RP080026) over the electric fuel pump.
9. Using a pick made of soft material, such as a toothpick, remove the old O-rings from the FCC head.

CAUTION: The mounting head O-ring grooves may be damaged by using sharp steel tools to remove the O-rings.

CAUTION: Use only fuel approved O-rings (R047241) provided in RP080026 Kit. Use of non-approved O-rings may cause fuel to leak from the FCC.

10. Install the new O-rings in the same location. Lubricate the new O-rings with a fuel resistant O-ring lubricant.
11. Apply pipe sealant, suitable for use with gasoline, to the threads of the 7/16" plug.
12. Install and tighten the 7/16" plug into the canister.
13. Install the canister firmly back onto the FCC head.
14. Reinstall the retaining clamp and tighten securely.

ENGINE MAINTENANCE - 11

15. Reconnect the fuel supply line to the LPFP.
16. Reconnect the two-wire electrical connectors to the FCC and the LPFP.
17. Cycle the ignition key several times to run the electric fuel pumps and fill the FCC bowl with fuel. Inspect the drain plug area for leaks. Correct any leaks prior to operating the engine.
18. Start the engine and inspect for fuel leaks. Correct any leaks prior to operating the engine any further.

DO NOT ATTEMPT TO SERVICE ANY OTHER PARTS ON THIS UNIT.

Servicing the Primary Fuel Pre-Filter

The frequency of replacing the filter element is determined by the contamination level of the fuel. Replace the filter element after the first 25 hours, then every 50 hours or once a year (whichever occurs first).

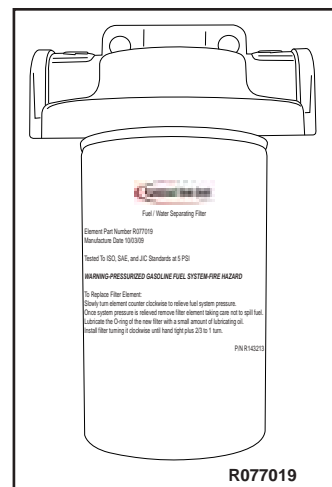

Priming Fuel System

To prime the fuel system, cycle the ignition key 3 times using the following procedures:

1. Turn ignition key to ON position for 5 seconds.
2. Turn ignition key OFF.
3. Pause for 10 seconds.
4. Repeat steps 1-3 three times.

Crank the engine until it starts or 30 seconds elapse. If the engine does not start, repeat the priming procedures.



WARNING

Improper use, installation or servicing may cause an explosion or fire resulting in bodily injury, or death. This unit should only be serviced by a qualified technician. Read and follow all instructions before proceeding. Run the engine and check for fuel leaks after installation or element replacement.

Filter Element Replacement, ENGINE OFF

PRIMARY FUEL PRE-FILTER #: R077019 (SPIN-ON)

NOTE: This filter may be located in various locations. Consult your boat manufacturer's operation manual for correct location.

1. Loosen the fuel filter by spinning it counterclockwise. A filter wrench may be required.
2. Remove the filter. Ensure that the old O-ring is removed with the filter.
3. Install the new filter by spinning it on clockwise. Ensure the new filter is installed correctly. Tighten the filter securely.
4. Start the engine and inspect for fuel leaks. Correct any leaks prior to operating the engine any further.



WARNING

Make sure there are no fuel leaks before closing the engine hatch.

FLAME ARRESTOR

At specified intervals, the flame arrestor should be checked for blockage caused by dirt or other foreign material.

Loosen the fastener securing the flame arrestor to the air intake throttle body. Remove the flame arrestor. Clean the flame arrestor with solvent and dry with compressed air. Reinstall the flame arrestor and tighten the fastener securely.

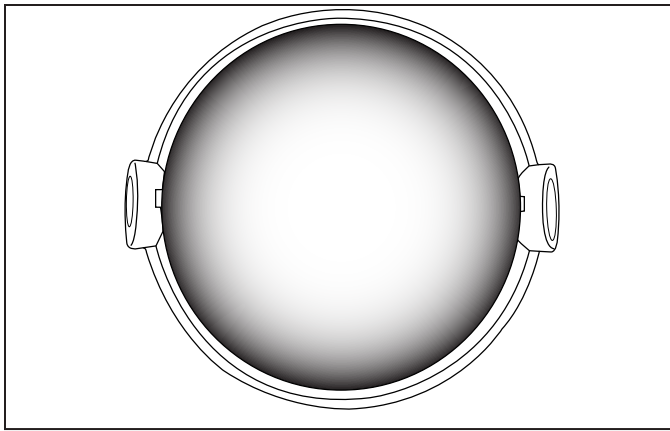

Figure 11-16 Flame Arrestor

ACCESSORY DRIVE BELT

PCM engines use a single serpentine belt to drive the engine water circulation pump, sea-water pump and the alternator.



WARNING

Engine must be shut OFF and the ignition key removed before inspecting the drive belt(s). The drive belt(s) should be checked periodically for condition and tension. If the belt(s) shows signs of cracking, glazing or deterioration, replace with new belt(s).

DRIVE BELT INSPECTION

Inspect the drive belt for excessive wear, shredding or missing sections.

Inspect the drive belt for contamination from excessive dirt, oil, coolant or other substances that may effect the drive belt operation.

If a problem is found, replace the belt after inspecting the following items:

- All pulleys and tensioners for signs of misalignment
- All pulleys and tensioners for signs of rust or other damage
- Bent pulleys or tight bearings in the engine water circulation pump, sea-water pump and alternator

DRIVE BELT REPLACEMENT

Part Number: R066040

1. Note the routing of the belt before removing.
2. Using a 15 mm box wrench or socket, turn the belt tensioner to relieve the tension on the belt. Slide the belt off of the pulleys. **Release the tensioner slowly to prevent the tensioner from snapping against its stop, and possibly causing damage to the tensioner.**
3. Slide the new belt onto the pulleys using the same routing as noted prior to removal.
4. Compress the belt tensioner, and slide the belt over the tensioner pulley. Release the tension slowly to tension the belt.

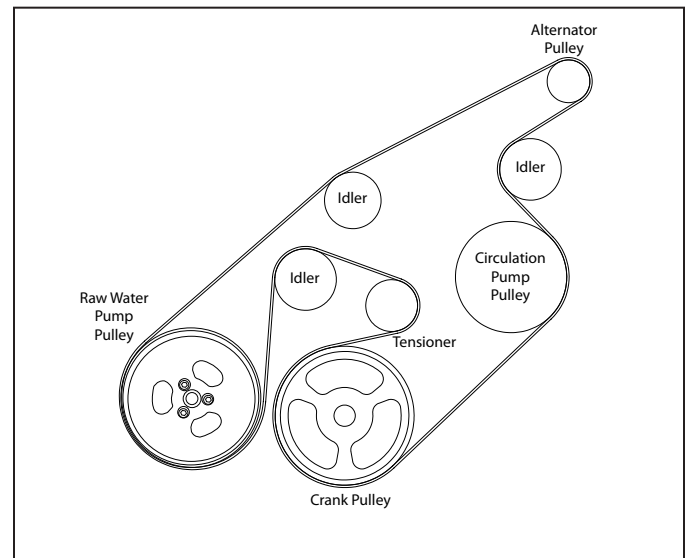

Figure 11-17 Accessory Drive Belt Configuration



Figure 11-18 Belt Tensioner

ENGINE MAINTENANCE - 11

SERVICING RAW WATER PUMP IMPELLER

IMPELLER KIT #: RP061022

The raw water pump impeller should be serviced every 50 hours, or once a year, whichever occurs first. See Maintenance Schedule.

Locations "A" (Figures 11-17 / 11-19) are access holes in order to loosen the raw water pump attaching bolts. The bolts are secured in the pump by O-rings, and will not fall out during removal.

Torque the raw water pump housing attaching bolts to 8.5-9 ft.lbs. (11.5-12 N-M), when re-installing the impeller.

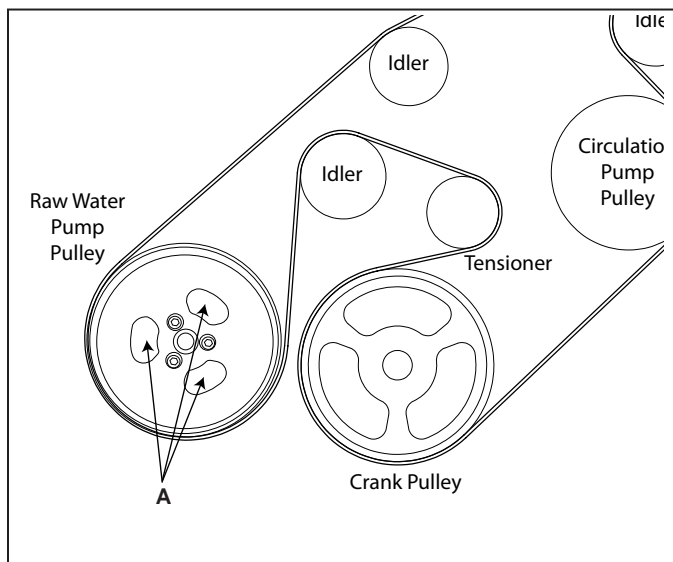

CHANGING OILS



WARNING

IMPORTANT: The Federal Water Pollution Control Act prohibits the discharge of oil or oily waste into or upon the navigable waters and continuous zone of the United States, if such discharge causes a film or sheen upon, or discoloration of the surface of the water, or causes sludge or emulsion beneath the surface of the water. Violators are subject to a penalty of \$5,000.00.

Refer to the MAINTENANCE SCHEDULE for oil change intervals. The engine and transmission oils should be changed prior to placing the boat into storage.

The transmission oil change should be performed by an authorized PCM Premier dealer, at specified intervals. Transmission fluids should be removed through a copper tube, that extends to the bottom of the transmission case, using a suction/vacuum type fluid extractor.

IMPORTANT: Change the engine oil when the engine is warm from operation. Warm oil flows more freely, and allows more foreign material and impurities to be removed.

The engine oil filter is remote mounted. The engine block location, where the filter is normally mounted, is covered with an oil filter bypass adapter. DO NOT remove this adapter when changing the oil.



CAUTION

DO NOT OVERFILL ENGINE CRANKCASE WITH OIL. Excessive oil can lead to premature engine component failure and/or loss of performance.

1. With the engine at normal operating temperature, locate the oil pan quick drain hose and thread the hose through the boat's drain plug hole. (Figure 11-21). Remove the cap from the end of the quick-drain hose and insert the discharge hose into a suitable container. Allow the oil from the engine to drain until the crankcase is empty. Reinstall the cap onto the quick-drain hose and pull the hose back through the drain and secure the hose at the engine.
2. Remove the oil filter by turning it counterclockwise, using an oil filter wrench if necessary. Discard the old filter and sealing ring.
3. Coat the sealing ring, on the new filter, with a light coating of clean engine oil. Install the oil filter securely by hand. DO NOT overtighten.

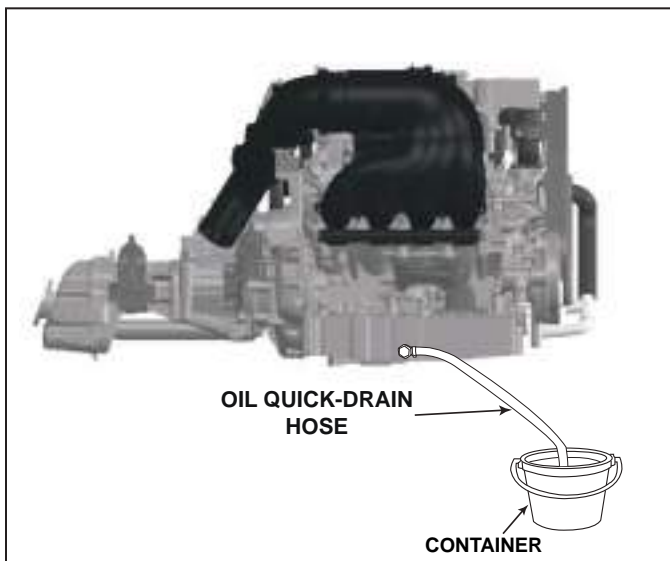

Figure 11-21 Engine Oil Removal

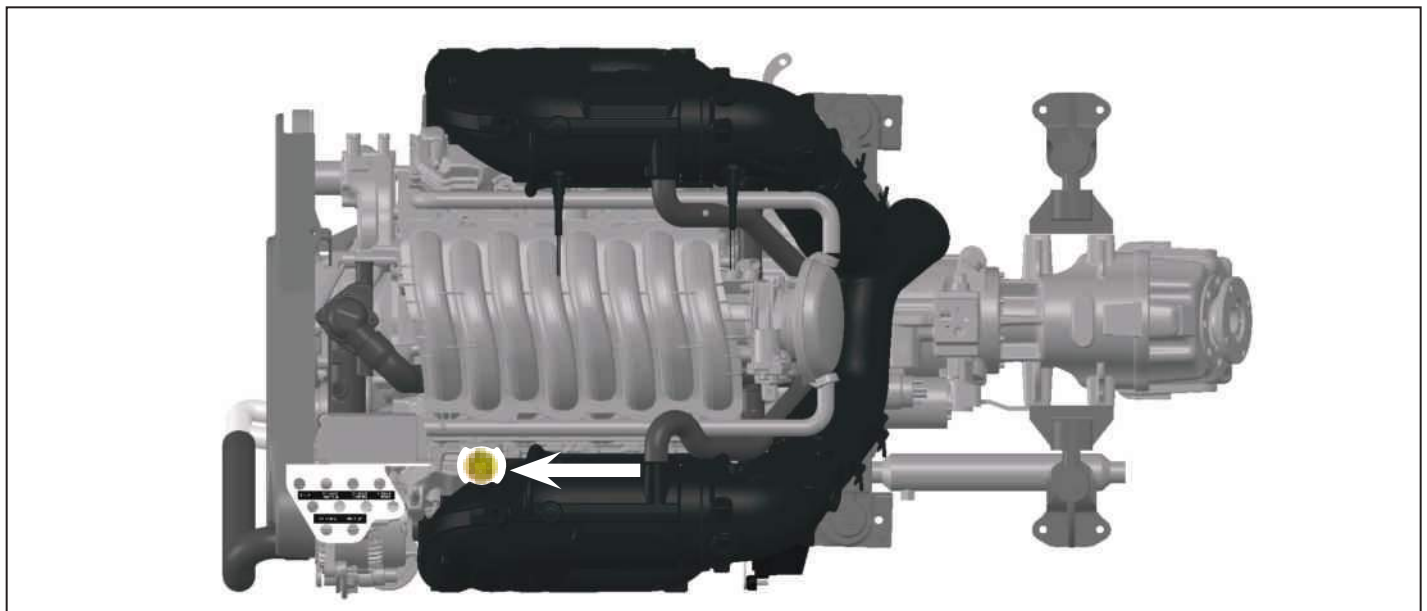

Figure 11-22 Engine Oil Fill

4. Fill the engine with the recommended oil and quantity, through the oil fill location on the valve cover (Figure 11-22). See **OIL REQUIREMENTS** and **ENGINE FLUID CAPACITIES**.
5. Start the engine and operate for 2 minutes to circulate the oil throughout the engine. Check entire system for leaks, especially around the oil filter.
6. Stop the engine and wait 5 minutes to allow the oil to completely drain down. Check the oil level. Add or remove oil, as needed, to bring the engine oil to the proper level. See **CHECKING FLUID LEVELS** for Important Notes and Cautions to observe when checking the engine crankcase oil level.

IF YOU ARE UNSURE OF THE CORRECT AMOUNT OF OIL TO USE DURING A SERVICE INTERVAL, PERFORM THE FOLLOWING PROCEDURE:

- (1) Drain the oil and change the oil filter.
- (2) Add six (6) quarts of new oil.
- (3) Start and run the engine allowing sufficient time for the new oil to circulate and fill the new oil filter.
- (4) Shut the engine off. Wait 5 minutes to allow the oil to completely drain back to the pan. Check the oil level with the dipstick and add the correct amount of oil to fill to the "FULL" mark on the oil level dipstick.

ENGINE MAINTENANCE - 11

ENGINE ALIGNMENT



CAUTION

Engine must be properly aligned, or vibration, noise and damage to the transmission output shaft, oil seal, and bearings may result.

IMPORTANT: For PCM Power-Plus V-Drive applications, adjust the engine and V-Drive mounts to achieve alignment. The Transmission mounts are for support only and, are not used to achieve proper alignment.

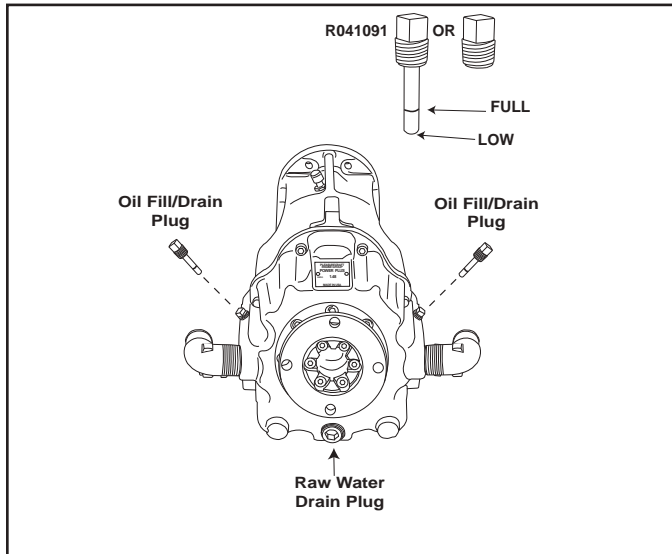

Figure 11-23 PCM V-Drive

V-DRIVE ALIGNMENT

The Transmission support mounts must be removed before performing the engine alignment. Alignment is achieved using the Engine front mounts and the PCM V-Drive rear mounts.

- Alignment with a PCM V-Drive: loosen the trunnion bolts on the TRANSMISSION mounts, then remove the bolts used to attach the mount to the Transmission. Slide the mount away from the transmission.

Perform the Engine Alignment as outline in the following steps. When you have completed the alignment you will need to re-install the mounts onto the Transmission. The Transmission mounts may need to be adjusted so there is no tension on the mounting bolts as they are re-installed. Re-tighten all trunnion bolts to complete the V-Drive alignment.

NOTE: Some PCM V-Drive configurations use only engine and transmission mounts. Alignment is accomplished using those mounts.

ENGINE ALIGNMENT

IMPORTANT: Engine alignment **MUST BE RECHECKED** with the boat in the water, fuel tanks full and with a normal load on the boat. Engine must be aligned so that the transmission and the propeller shaft coupling center lines are aligned, and coupling faces are parallel within 0.003 in. (0.07 mm). This applies to installations with solid couplings, as well as flexible couplings.

1. Check the mating surfaces on the transmission and the propeller shaft couplings. Make sure they are clean and flat (Figure 11-24).

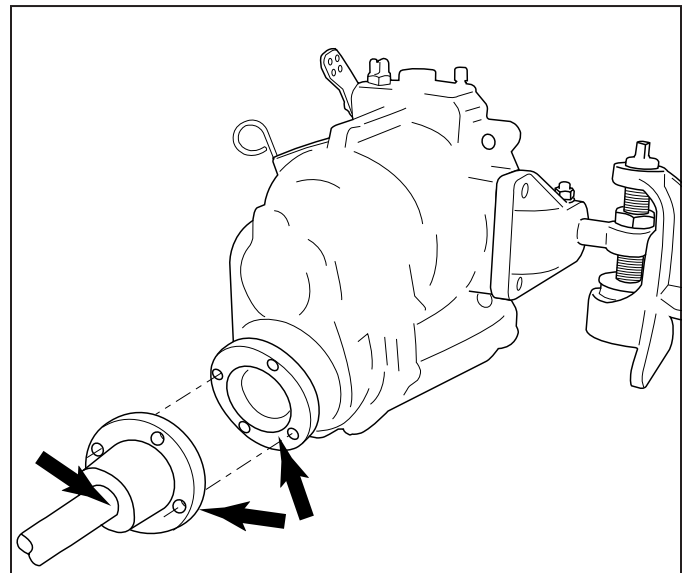

Figure 11-24 Shaft Mating Surface Check

2. Center the propeller shaft in the shaft log as follows: (Figure 11-25)
 - Push down and then lift the propeller shaft as far as it will move, then place the shaft in the middle of the movement.
 - Move the shaft to the port and then to the starboard as far as the shaft will move, then place the shaft in the middle of the movement.
 - With the propeller shaft in the middle of the shaft log, align the engine to the shaft.

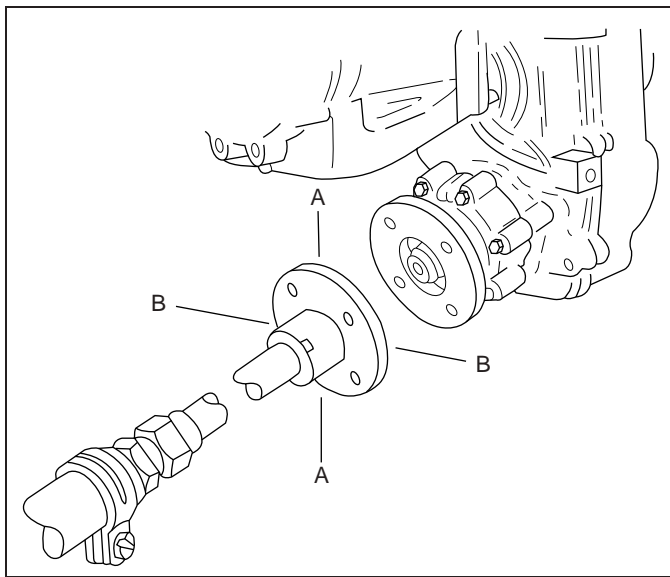

Figure 11-25 Centering Prop Shaft

3. Check that the coupling center lines align by butting the propeller shaft coupling against the transmission coupling (Figure 11-26). The shoulder on the propeller shaft coupling face should engage the recess on the transmission coupling face, with no resistance.

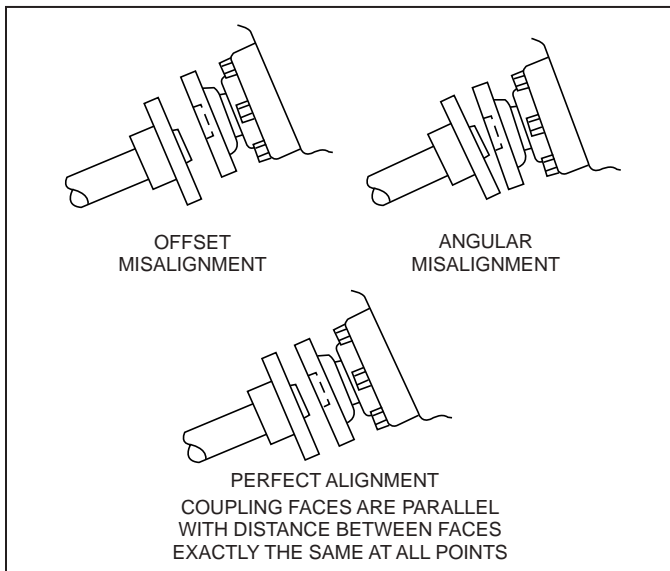

Figure 11-26 Shaft Mating Surface Check

IMPORTANT: Offset misalignment conditions must be corrected prior to checking for angular misalignment.

NOTICE: Some propeller shaft couplings may not have a shoulder on the mating surface. On these installations, use a straight edge to check the centerline alignment (Figure 11-27).

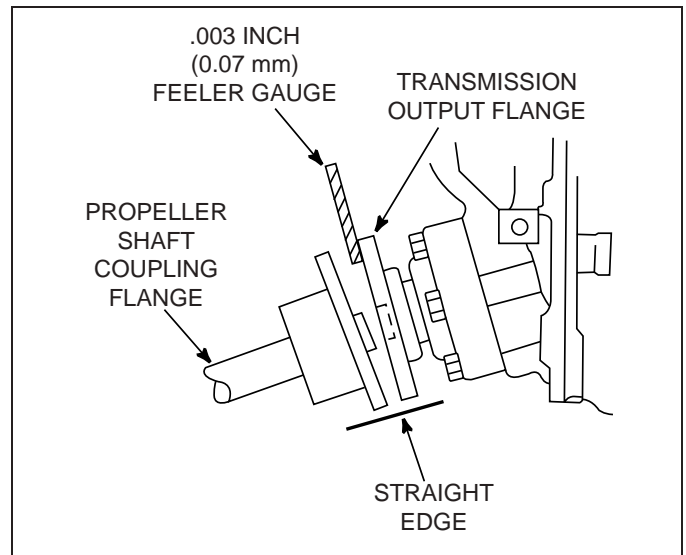

Figure 11-27 Angular Alignment

OFFSET ALIGNMENT:

4. If the coupler center lines are not aligned, adjust the mounts as follows:
 - UP or DOWN OFFSET ADJUSTMENT: Loosen the locking nut. Turn the adjusting nut or the adjusting bolt in the direction required to raise or lower the engine. After the adjustment is complete, tighten the locking nut.

IMPORTANT: For Offset Alignment, both front mounts (or rear mounts) must be turned equally or angular misalignment will occur.

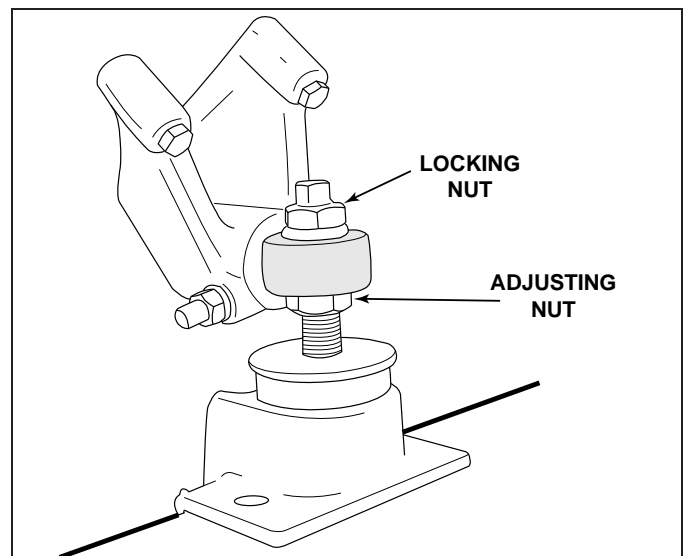

Figure 11-28 Mount Adjustment

ENGINE MAINTENANCE - 11

- LEFT or RIGHT ADJUSTMENT: Loosen the trunnion clamping bolt and the nut on all four mounting brackets. Move the engine to the left or right, as necessary, to obtain the proper alignment. After adjustment is complete, tighten all bolts.

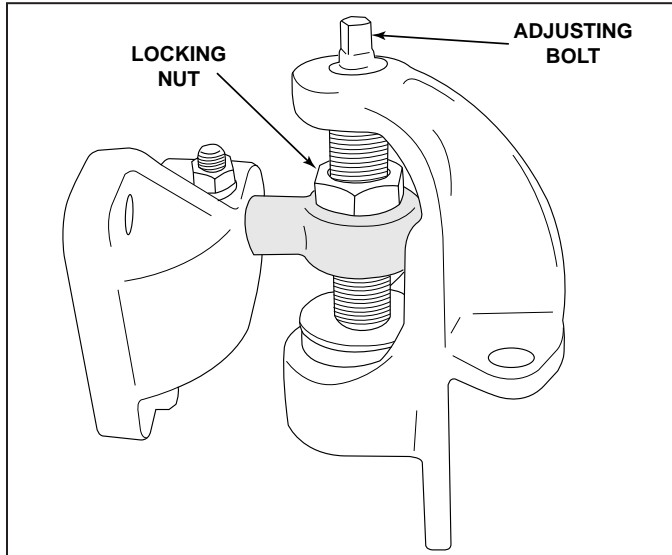

Figure 11-29 Mount Adjustment

IMPORTANT: The large diameter of the mount trunnion **MUST NOT** extend over 1.750 in. (44.45 mm), from the mounting brackets on any of the mounts; and a sufficient amount of the trunnion must remain in the mount to be secured by the trunnion locking bolt.

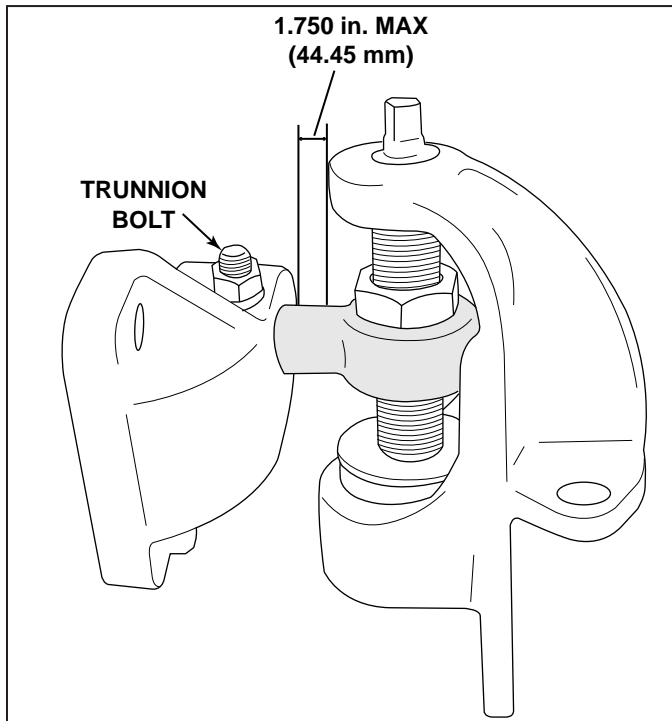

Figure 11-30 Engine Extension

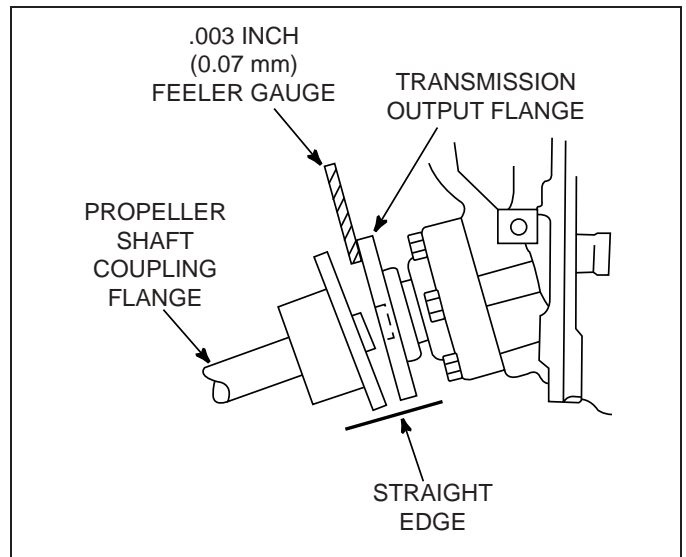

Figure 11-31 Angular Alignment

5. Check for any angular misalignment. Hold coupling faces tightly together by hand and check for a gap between the coupling faces, with a 0.003 in. (0.07 mm) feeler gauge, at 90-degree intervals. (Figure 11-31).

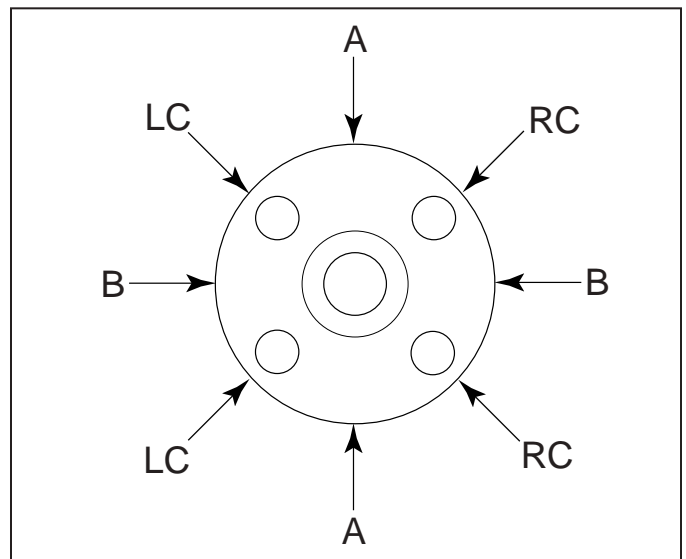

Figure 11-32 Angular Alignment Check

IMPORTANT: Angular misalignment conditions may require adjustment of one front mount, both front mounts, the trunnions, or any combination. Figure 11-32 (Angular Alignment Check) and the following table are to assist in the alignment process.

Angular Misalignment	Front Mount Adjusted
A	Both
B	Trunnion
LC	R
RC	L

- To adjust a corner of the engine up or down, loosen the locking nut. Turn the adjusting nut or the adjusting bolt in the direction required to raise or lower the engine. After the adjustment is complete, tighten the locking nut.

IMPORTANT: If a “pinch” occurs in the “A” quadrant (Figure 11-32), correcting the condition will require an equal adjustment on the front mounts. If a “pinch” occurs in the “C” quadrant, an adjustment will be made on the opposing front mount. If a “pinch” occurs in the “B” quadrant, a trunnion adjustment is required.

- To move the engine left or right, loosen the trunnion clamping bolt and the nut on all four mounting brackets. Move the engine to the left or right, as necessary, to obtain the proper alignment. After adjustment is complete, tighten all bolts.
- After the engine has been properly aligned, secure the engine mounts.
 - Connect the propeller shaft coupling to the transmission coupling. Tighten the coupling attaching bolts and nuts to the correct specifications.

FASTENER TORQUE SPECIFICATIONS

Location	Lb-Ft (N·m)
Engine Mount to Stringer	Securely
Propeller	50 (68)
Trunnion Bolts	45 (61)

ENGINE MAINTENANCE - 11

MAINTENANCE SCHEDULE

Location and Service	Check Daily	After 1st 25 Hrs of Operation	Every 50 Hours of Operation	Every 100 Hours of Operation	Once Each Year
Check coolant level - Fresh-water cooled models only	X				
Check oil level - Engine crankcase	X				
Check oil level - Transmission	X				
Engine Assembly (complete - Check for obvious leaks (water, oil, fuel and exhaust)	X				
Remote Control and Steering System - Check for proper operation	X				
Sea Strainer - Check (if equipped)	X				
Partial Cooling System - Check and clean screen on inlet side of exhaust cooling thermostat housing as required.		X	X		X
Cooling System - Check condition and tightness of all hose clamps		X		X ¹	X
Cooling System - Inspect/Replace raw water pump impeller			X		X
Drive Belt - Inspect condition and check tension		X		X	X
Exhaust System - Check condition and tightness of all hose clamps		X		X ¹	X
Exhaust System - Check for water leaks at the manifold, riser and elbow gaskets	X				
Ignition System and Spark Plugs - Clean and inspect condition		O		O	O
Engine Assembly (complete) - Check for loose, missing or damaged parts (especially engine mounts, starter and alternator mounting fasteners)		X		X	X
Change engine oil and filter		X	X		X
Engine Alignment - Check and adjust if necessary		O			O
Ignition Timing - Not Adjustable					
Battery - Check electrolyte level and specific gravity. Inspect case for damage. Check cables and connections.		X	X		X
Electrical System (complete) - Check for loose or dirty connections and damaged wiring			X ²		X
Flame Arrestor and Crankcase Ventilation System - Clean and inspect				X	X

ENGINE MAINTENANCE - 11

MAINTENANCE SCHEDULE (cont'd)

Location and Service	Check Daily	After 1st 25 Hrs of Operation	Every 50 Hours of Operation	Every 100 Hours of Operation	Once Each Year
Hoses (all) - Inspect for cracks, swelling, weather checking or other signs of deterioration				X	X
Shift and Throttle Cable Linkage - Inspect and lubricate (A)				X ¹	X
Fuel Filters - Service or replace		O	O		O
Transmission - Change fluid (B) and clean strainer, if equipped		O			O
'V'-Drive Transmissions - Change fluid (C) and clean strainer, if equipped		O			O

MAINTENANCE SCHEDULE (cont'd)

Fresh-water cooled models - Clean sea-water section	As required ³ (X)
Fresh-water cooled models - Check coolant for alkalinity	At least once each year (X)
Fresh-water cooled models - Change coolant	Every five years
Zinc Anodes - Heat exchanger and cooler - check condition	Every 30 days ³ (X)
Engine Assembly Exterior Surfaces - spray with rust-preventative oil (D)	Fresh water areas - Every 60 days (X) Salt water areas - Every 30 days (X)
Cooling System (SALT WATER AREAS ONLY) - Flush sea-water section	After use each day (X)

Notes:

- (X) Denotes service to be performed by the owner/operator
- (O) Denotes service to be performed by an authorized PCM Engines Premier dealer
- (A) Use SAE 30 engine oil
- (B) All PCM, Velvet Drive and Hurth transmissions - Use Dexron III automatic transmission fluid
- (C) All PCM Power-Plus "V" Drive transmissions are designed to be 'Maintenance Free'. Inspect fluid level after the first 25 hours of use and annually thereafter. Fluid should only be changed if evidence of contamination is present. Use Mobiltrans SHC 50 synthetic transmission lubricant. PCM P/N: R190250
- All Walters "V" Drive transmissions - Use Exxon Spartan EP-68 or SAE 30 engine oil
- All Velvet "V" Drive transmissions - Use Dexron III automatic transmission fluid

(D) Use WD-40 penetration oil or equivalent

¹ In fresh-water areas, every 100 hours of operation or 120 days (whichever occurs first). In salt-water areas, every 50 hours of operation or 60 days (whichever occurs first).

² In fresh-water areas, every 50 hours of operation or 60 days (whichever occurs first). In salt-water areas, every 25 hours of operation or 30 days (whichever occurs first).

³ Requires more frequent inspection if used in extremely salty, polluted or mineral-laden waters.

⁴ See COOLANT SPECIFICATIONS.

PCM Engines recommends that all periodical and annual service be performed by your local, authorized PCM Engines Premier dealer.

VISUAL INSPECTION

It is important for the owner/operator to visually inspect the complete engine assembly at regular intervals. Most often, costly repairs can be avoided if potential problems are corrected before there is a failure.

Inspect the complete engine assembly for obvious fuel, oil, water or exhaust leaks. Check for loose, damaged or missing parts. Check all hose clamps for adequate tightness. Check the electrical system for loose or dirty connections or damaged wiring.

Touch up scratches, nicks and corrosion damage to the exterior finish of the engine. Spray paint may be obtained from your local PCM Engines dealer.

Protect engine finish from corrosion by periodically spraying the engine exterior finish with a rust preventative oil (such as WD-40).

ENGINE FLUID CAPACITIES

Model	ALL MODELS
Crankcase Oil Capacity W / NEW FILTER	Start with 6 Quarts (5.7L) ¹
Fresh Water Cooling System Capacity	Fill Until Completely Purged ³

TRANSMISSION FLUID CAPACITIES

Model	All Models	Type
PCM, 1:1 Ratio ^{1,2}	2.0 Quarts (1.9L)	DEXRON III
PCM, 1.23:1 Ratio ^{1,2}	2.0 Quarts (1.9L)	DEXRON III
PCM Power-Plus V-Drive, All Ratios ^{1,2}	1.5 Quarts (1.42L)	Mobiltrans SHC 50 synthetic - R190250

- 1 - **Engine Fluid Capacities are dependent on installation angle. DO NOT** overfill the crankcase or transmission. Remove excess fluid above the "FULL" mark on the dipstick. Check oil with the boat at its normal, level, at rest position on the water. Ensure that ballast systems (if equipped) and excess water in the bilge have been purged. If the boat is on a trailer, the trailer must be level and adjusted to represent the boat's normal resting state on the water. Oil capacities are approximate, and may not include capacity needed for transmission cooler and oil lines. Refer to the **Checking Fluid Levels** instructions and **Changing Oils** instructions of this manual, for complete instructions, important notes and Cautions for checking engine oil levels. Always use the dipstick to determine the exact quantity of oil required. Add the correct amount of oil to fill to the "FULL" mark on the oil level dipstick.
- 2 - Refer to the **Checking Fluid Levels** instructions of this manual for complete instructions for checking transmission fluid levels. **IMPORTANT:** 80 Series PCM 1:1, 1.23:1 and all other transmission fluid levels are checked at operating temperature and immediately after shutdown of the engine.
- 3 - Fresh Water Cooling systems vary depending on half-systems, full-fresh systems, heaters, hose lengths, etc. System should be completely purged of air and the coolant level should be within the MIN/MAX level of the degas bottle after the engine has been ran at operating temperature and the system is allowed to cool down overnight. Top off as necessary. Refer to FILLING FRESH-WATER COOLING within this section.

ENGINE MAINTENANCE - 11

FILTER REQUIREMENTS

Description	Part No.
Oil Filter (remote-mounted)	R077001
Kit, Transmission Oil Filter	RP077011
Primary Fuel Pre-Filter	R077019
Fuel Control Cell (FCC) Fuel Filter Element	RP080026

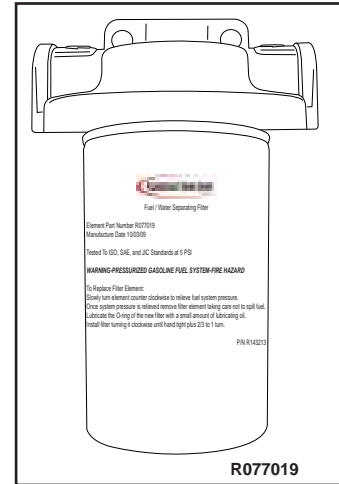
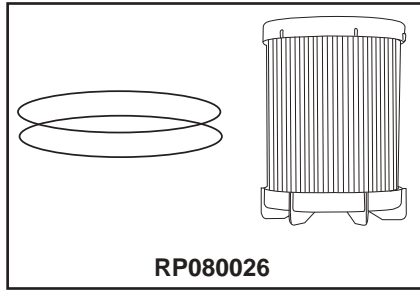

PCM POWER-PLUS V-DRIVE LUBRICANT

Description	Part No.
PCM Power-Plus V-Drive Lubricant (1 qt. bottle)	R190250

ENGINE SPECIFICATIONS - 12

MASTER ENGINE SPECIFICATIONS

MODEL	5.3L DI CES	6.2L DI CES
Displacement	5.3L (327 CID)	6.2L (383 CID)
Bore	3.78 in. (96.01 mm)	4.06 in. (103.25 mm)
Stroke	3.62 in. (92.0 mm)	3.62 in. (92.0 mm)
Compression Ratio	11:1	11.5:1
Compression	130 - 215 psi	130 - 215 psi
WOT Operating RPM Preferred WOT RPM	5300-5600 5500	5300 - 5600 5500
Cruising RPM (Max)	4000	4000
Idle RPM (In Gear)	Not Adjustable	Not Adjustable
Oil Pressure @ 2000 RPM	25 - 60 psi (172 - 414 kPa)	25 - 60 psi (172 - 414 kPa)
Minimum Oil Pressure	22 psi (152 kPa) - 1000 RPM 30 psi (207 kPa) - 2000 RPM 33 psi (228 kPa) - 3000 RPM	22 psi (152 kPa) - 1000 RPM 30 psi (207 kPa) - 2000 RPM 33 psi (228 kPa) - 3000 RPM
Spark Plug P/N Spark Plug Gap	R030013 0.040 in.	R030013 0.040 in.
Firing Order	1-8-7-2-6-5-4-3	1-8-7-2-6-5-4-3
Thermostat	Vented Thermostat Temperatures can vary with pressures	Vented Thermostat Temperatures can vary with pressures
Over- Temperature	200° F (93.3° C)	200° F (93.3° C)
Electrical System	12 Volt Negative (-) Ground	12 Volt Negative (-) Ground
Alternator Rating	100 Amps	100 Amps
Ignition Timing	Not Adjustable	Not Adjustable
CAM Retard	Not Adjustable	Not Adjustable
Battery Rating	650 CCA (Minimum) 120 Ah	650 CCA (Minimum) 120 Ah

NOTE: FOR NEW BOAT PROPPING, IT IS RECOMMENDED THAT OEMS PROP TO THE MAXIMUM RPM LISTED.

ENGINE SPECIFICATIONS - 12

LH ROTATION
FRONT

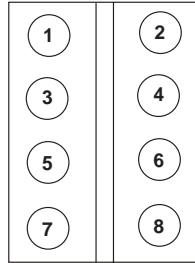

NO
DISTRIBUTOR
FLYWHEEL END OF ENGINE
ALL V-8 MODELS



FIRING ORDER:
1-8-7-2-6-5-4-3

PCM FUEL PRESSURE and ALARM WARNING SPECIFICATIONS

MODEL	ALL	NOTES
FCC Fuel Pressure	57-62 psi @ WOT	Monitored with sensor and displayed on Diacom Diagnostic Tool.
Fuel Rail Operating Pressure	580 psi - 2100 psi	Monitored with sensor and displayed on Diacom Diagnostic Tool.
Fuel Pressure - LPFP ALL ENGINES	7 - 9 psi (WOT)	
Coolant Over Temperature	200°F / 215°F DTC 116 / 117 MIL and Buzzer Engine Derates	Causes engine to go into Power Derate.
Exhaust Manifold Riser Temperature Sensors (Raw Water Applications)	235°F / 245°F DTC 1415 / 1416 / 1417 / 1418 MIL and Buzzer Engine Derates	Causes engine to go into Power Derate.
Exhaust Manifold Riser Temperature Sensors (Fresh Water Applications)	250°F / 258°F DTC 1415 / 1416 / 1417 / 1418 MIL and Buzzer Engine Derates	Causes engine to go into Power Derate.
Low Engine Oil Pressure	< 5 psi @ idle / < 35 psi @ 4000 (Stage 1) < 30 psi @ 4000 (Stage 2) DTC 524 / 520 MIL and Buzzer Engine Derates	Causes engine to go into Power Derate.
Closed Loop Control Out of Range	DTC 1155 / 1156 DTC 1157 / 1158	Causes engine to go into Power Derate.
Adaptive Fuel Control Out of Range	DTC 171 / 172 DTC 174 / 175	Causes engine to go into Power Derate.

IMPORTANT: FUEL PRESSURE VALIDATION MUST BE MADE WITH THE ENGINE UNDER LOAD.

ENGINE STORAGE

IMPORTANT: This service should be performed by an Authorized PCM Premier dealer.



CAUTION

Refer to **FLUSHING COOLING SYSTEM** before proceeding.

1. Fill the fuel tanks with gasoline and add a sufficient amount of gasoline stabilizer, such as STA-BIL™ fuel stabilizer, to prevent the formation of fuel gum and varnish. Follow the instructions on the container.



WARNING

On fuel injected engines, you **MUST** bleed off fuel pressure before proceeding. Failure to do so may cause personal injury.

2. Remove, empty and clean the fuel filter assembly. Reinstall with a new fuel filter and gasket / seals. Refer to Engine Maintenance for filter replacement procedures.

NOTE: DO NOT re-use old fuel filter components. Always replace with new fuel filter element and gasket / seals.



WARNING

Accumulation of water and other fuel contaminants may form corrosive compounds that can damage the fuel filter, and result in fuel leakage. Ethanol blended fuel may increase this risk. For this reason, annual replacement of the fuel filter, at a minimum, is required to avoid risk of explosion or fire.



WARNING

Operate the bilge blower and be sure no fuel vapors are present when treating the engine. Be sure the engine compartment is well-ventilated to prevent a potential fire hazard.

3. Run the engine and allow it to reach normal operating temperature (a minimum of 10 minutes). Shut down the engine and change the oil and oil filter (See ENGINE MAINTENANCE).
4. Flush the cooling system if operating in salt water or brackish water areas. (See ENGINE MAINTENANCE).



WARNING

Operate the bilge blower and be sure no fuel vapors are present when treating the engine. Be sure the engine compartment is well-ventilated to prevent a potential fire hazard.

5. Restart the engine and allow it to idle for 5 minutes.
6. Turn off the ignition. If fogging the engine is required for extended storage, remove the spark plugs. Use an aerosol-type fogging solution and spray a sufficient amount of oil into each cylinder spark plug hole. (Follow the instructions for the storage oil used.) Turn the crankshaft several revolutions by hand to spread the oil evenly throughout the cylinders. Install the spark plugs and connect the spark plug wires.



CAUTION

Excess storage oil in the engine's cylinders can cause hydrostatic locking to occur, and severe damage to the engine.

7. Remove and clean the flame arrestor and the vent hoses, and reinstall on the engine. Cover the throttle body assembly, to prevent the possibility of the water entering the engine through the throttle body assembly, during storage.
8. Close the fuel shut-off valve (if equipped).

OUT-OF-SEASON STORAGE - 13

DRAINING INSTRUCTIONS

IMPORTANT: *These services should be performed by an Authorized PCM Premier dealer.*



CAUTION

If the boat is to remain in the water during or after draining, close the seacock to prevent a siphoning action that may occur, allowing sea water to flow from drain holes or removed hoses.

IMPORTANT: When removing the drain plugs, insert a wire into the hole to remove any obstruction which would prevent water from draining completely.

IMPORTANT: The fresh-water section of the cooling system must be kept filled year around with recommended coolant. Make certain that the cooling system is protected with an ethylene glycol antifreeze mixture properly mixed to protect the engine to the lowest temperature that it will be exposed to.

See the ENGINE MAINTENANCE section for testing alkalinity, draining and refilling procedures of the Fresh Water Cooling System, as required.

IMPORTANT: Drain the sea-water section of the cooling system only.

1. Remove all the drain plugs and/or hoses according to the correct application found in the WATER DRAINING DIAGRAMS section of this manual.

NOTICE: It may be necessary to bend or lift the hoses to allow water to drain completely.

2. Remove the raw water pump impeller. (See ENGINE MAINTENANCE) If inspection proves the impeller to be in good condition, store it in an accessible spot for re-installation at the end of the storage period. A damaged or badly worn impeller should be discarded and a new one installed at the end of the storage period.

NOTE: Removal of the impeller during storage will prevent the impeller vanes from drying and taking a permanent "set".

3. After the water has completely drained, coat the threads of drain plugs with PerfectSeal (or equivalent), and reinstall in the proper locations. Reinstall the hoses and tighten all the clamps securely.

After draining is completed, perform the additional required maintenance as outlined in the MAINTENANCE SCHEDULE under ONCE EACH YEAR.

BATTERY STORAGE

Follow the battery manufacturer's instructions for storage. If not available, use the following instructions:

- Remove the battery from the boat and clean, removing dirt and grease from the top of the battery.
- Fill the battery with distilled water to the manufacturer's specifications.
- Store the battery in a cool, dry place. Do not store on a concrete surface.
- Periodically (every 30 to 45 days), check the water level and recharge the battery to the manufacturer's specifications. Do not fast charge.



CAUTION

A discharged battery can be damaged by freezing.

RECOMMISSIONING AFTER STORAGE

IMPORTANT: *These services should be performed by an Authorized PCM Premier dealer.*

When recommissioning the engine after storage, the following items should be checked:

1. Assemble the raw water pump and reinstall on the engine.
2. Check all the cooling system hoses. Be sure they are properly connected and all the hose clamps are tight.



CAUTION

When installing the battery, make certain that you connect the POSITIVE (+) BATTERY CABLE to the POSITIVE (+) BATTERY TERMINAL first, and the NEGATIVE (-) BATTERY CABLE to the NEGATIVE (-) BATTERY TERMINAL last. If the battery cables are reversed, the electrical system will be damaged.



WARNING

Do not use jumper cables and/or a booster battery to start the engine. Do not recharge a weak battery in the boat. Remove the battery and recharge in a ventilated area away from fuel vapors, sparks or open flame.

3. Install the fully charged battery. Be sure that all the connections are clean and free from corrosion. Coat the battery terminal connections with an anti-corrosion battery terminal spray.
4. Readjust alternator and water pump drive belt tension.
5. Check engine alignment.
6. Check engine and transmission oil levels.
7. Check engine mount fasteners.

8. Open the fuel shut-off valve (if equipped).
9. Refer to the OPERATING INSTRUCTIONS section and perform all the safety checks before starting the engine.
10. Refer to the Engine Maintenance section and perform the Priming the Fuel System instructions.



CAUTION

If the engine(s) is (are) to be started prior to launching, use the procedure FLUSHING COOLING SYSTEM before proceeding to start the engine(s).

11. Open the seacock before starting the engine.
12. Start the engine and closely observe the instrument panel. Allow the engine to reach normal operating temperature. Inspect the engine carefully for fuel, exhaust, oil and water leaks.
13. Check the steering, shift and throttle controls for proper operation.

TROUBLESHOOTING - 14

Engine performance complaints usually fall under one of the basic headings listed in the Troubleshooting Guide. When a problem cannot be easily diagnosed, consult a PCM Engines Servicing Dealer for assistance.

Malfunction	Possible Cause	Corrective Action
<p>Engine will not crank with the starter motor, or cranks slowly.</p> <p>NOTICE: Battery voltage must be AT or ABOVE 10 volts while the engine is cranking or the engine management system will not function.</p>	<p>Problem with the engine management system.</p> <p>Battery switch turned OFF (if equipped)</p> <p>Remote control not in Neutral position.</p> <p>Blown ignition/starter fuse.</p> <p>Loose and/or dirty wiring connections.</p> <p>Dead Battery</p>	<p>Contact PCM Engines Dealer.</p> <p>Turn the battery switch ON.</p> <p>Position the remote control exactly in Neutral.</p> <p>Replace the fuse</p> <p>Check the battery cables and starter circuit wiring. Clean and tighten all connections. Repair or replace the damaged wiring.</p> <p>Recharge, test and replace as necessary.</p>
<p>Engine Cranks - will not start or is hard starting.</p> <p>NOTICE: Battery voltage must be AT or ABOVE 10 volts while the engine is cranking or the engine management system will not function.</p>	<p>Improper starting procedure.</p> <p>No fuel - empty fuel tank</p> <p>No fuel to the throttle body (TBI) or the injectors (MPI)</p> <p>Engine flooded</p> <p>Ignition system malfunction</p> <p>Contaminated fuel</p>	<p>Refer to "STARTING ENGINE" in the OPERATING INSTRUCTIONS section.</p> <p>Check the fuel tank level - fill tank(s). Open shut-off valve(s).</p> <p>Plugged fuel filters. Plugged or kinked fuel lines or plugged fuel-tank vent. Faulty fuel pump - check electrical connections. Faulty anti-siphon valve.</p> <p>Open the throttle 100% and crank the engine. When the engine starts, immediately return the throttle to 1000 RPM.</p> <p>Contact PCM Engines Dealer.</p> <p>Check fuel for water or other contamination. If contaminated, drain and clean the fuel system.</p>

TROUBLESHOOTING - 14

Malfunction	Possible Cause	Corrective Action
Transmission slipping - erratic operation	<p>Low oil level</p> <p>Transmission overfilled causing oil aeration</p> <p>Transmission shift lever not fully engaged</p> <p>Contaminated fluid</p>	<p>Add specified oil. Check the transmission for leaks.</p> <p>Drain required amount of oil.</p> <p>Adjust the shift linkage and remote control. Check the shift cables for freedom of movement and binding.</p> <p>Determine and correct the contamination source and change the fluid.</p>
Engine misses, runs rough and/or backfires	<p>Ignition system malfunction</p> <p>Plugged fuel filters</p> <p>Faulty fuel pump.</p> <p>Plugged or kinked fuel lines or fuel tank vent</p> <p>Anti-siphon valve faulty</p> <p>Flame arrestor dirty</p>	<p>Contact PCM Engines Dealer.</p> <p>Replace the fuel filters.</p> <p>Have fuel pump replaced by a PCM Engines Dealer/</p> <p>Repair or replace the fuel lines. Remove obstruction.</p> <p>Clean or replace as necessary.</p> <p>Clean the flame arrestor.</p>
Poor engine or boat performance	<p>Ignition malfunction</p> <p>Throttle not fully open</p> <p>Damaged or improper propeller</p> <p>Excessive water in the bilge</p> <p>Excessive growth on the boat bottom</p> <p>Boat overloaded</p> <p>Dirty flame arrestor</p> <p>Engine overheating</p>	<p>Contact PCM Engines Dealer.</p> <p>Check the remote control and throttle body linkage for freedom of movement and proper adjustment.</p> <p>Repair or replace as necessary.</p> <p>Pump the water out and investigate source of entry.</p> <p>Clean the bottom and paint with an anti-fouling paint.</p> <p>Reduce and/or redistribute the load.</p> <p>Clean the flame arrestor.</p> <p>Repair the cooling system (See "Engine Overheats").</p>

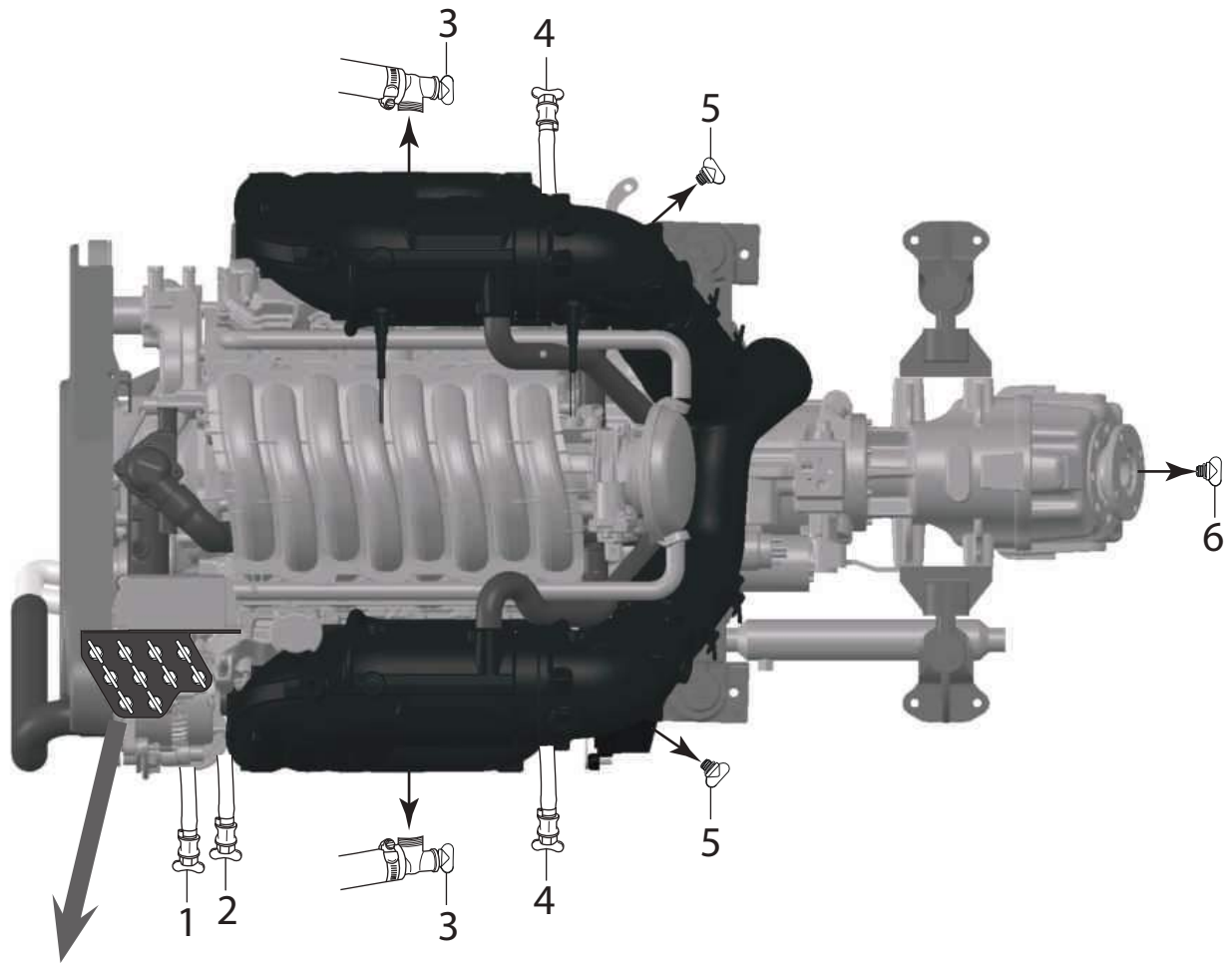
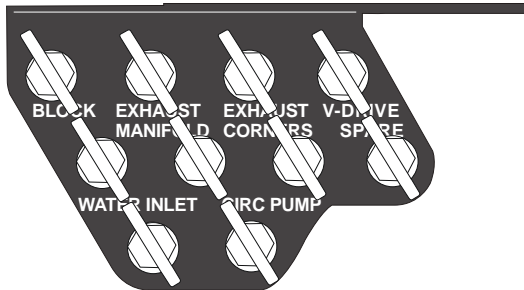

Figure 15-1 Raw Water CES 5.3L DI / 6.2L DI



RAW WATER DRAIN PLUGS

A drain plug bracket/holder is mounted above the alternator. This holder is designed to keep your drain plugs organized and secure until they need to be reinstalled. The drain plugs are BLUE for easy identification. Some locations have BLUE hoses that have the drain plugs located in the end of the hoses. Each location is identified above.

ANODES

There are anodes in the exhaust manifolds. Refer to the ENGINE MAINTENANCE section of this manual for proper locations and how to check them.

- 1 - Raw Water Inlet Manifold Hose Plug (1)
- 2 - Circulation Pump Hose Plug (1)
- 3 - Exhaust Manifold Plugs (2)
- 4 - Engine Block (2)
- 5 - Exhaust Corners (2)
- 6 - VDrive (1) / SPARE (Direct Drive)
SPARE (1)

VDrive Applications - 9 plug locations with 1 spare plug

DDrive Applications - 8 plug locations with 2 spare plug

RAW WATER DRAINING LOCATIONS - 15

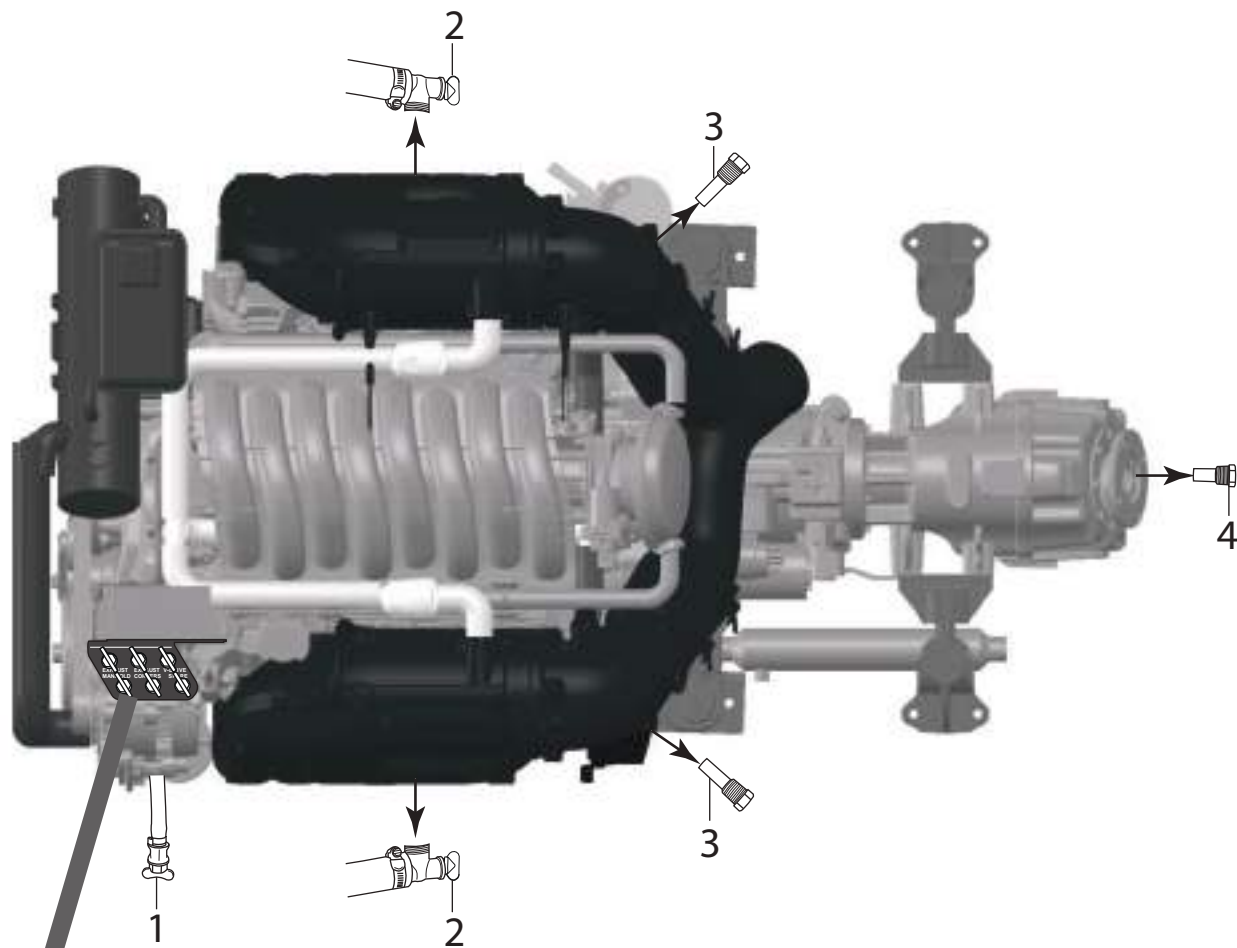

Figure 15-2 Fresh Water CES 5.3L DI / 6.2L DI

- 1 - Raw Water Inlet Manifold Hose Plug (1)
- 2 - Exhaust Manifold Plugs (2)
- 3 - Exhaust Corners - Remove / Inspect Anodes (2)
- 4 - VDrive - Remove / Inspect Anode (1) / Direct Drive - SPARE (1)
- SPARE (1)

RAW WATER DRAIN PLUGS

A drain plug bracket/holder is mounted above the alternator. This holder is designed to keep your drain plugs organized and secure until they need to be reinstalled. The drain plugs are BLUE for easy identification. Some locations have BLUE hoses that have the drain plugs located in the end of the hoses. Each location is identified above.

ANODES

There are anodes in the exhaust manifolds, exhaust corners, heat exchanger and VDrive. Refer to the ENGINE MAINTENANCE section of this manual for proper locations and how to check them.

Connecting a Heater

Raw Water Engines

1. Remove the “U” shaped hose from the engine circulation pump.
2. Connect the heater hose going out to the heater core to the fitting labeled “Outlet” below.
3. Connect the heater hose returning from the heater core to the fitting labeled “Return” below.
4. System will self-fill.

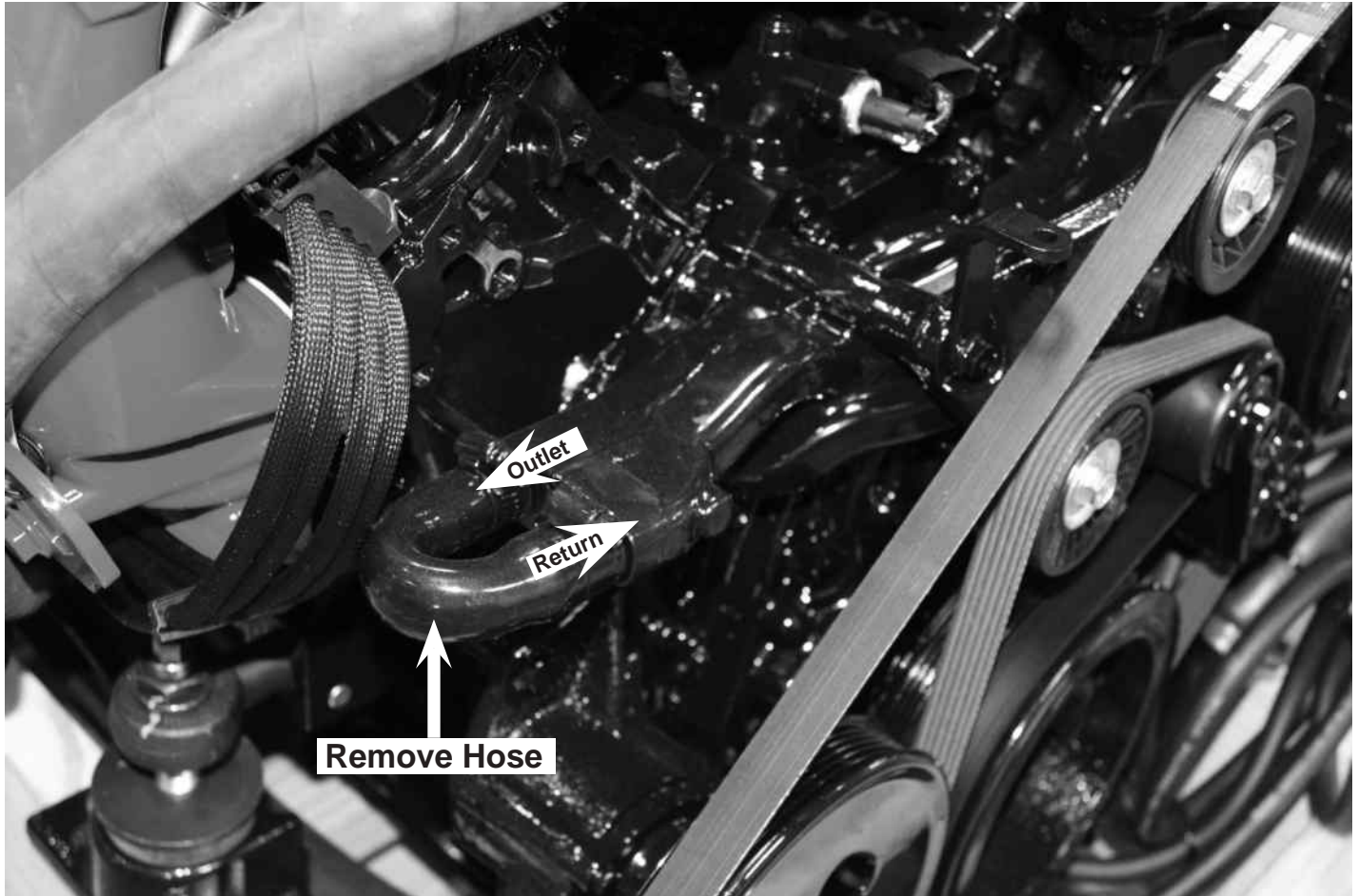

INSTRUMENTATION WIRING DIAGRAMS - 17

NOTE: ENGINE HARNESS WIRED FOR PANELS USING VOLTMETERS ONLY.

NOTE (A): POWER FOR A FUSED ACCESSORY PANEL MAY BE TAKEN FROM THIS LOCATION. LOAD CANNOT EXCEED 30 AMPS.

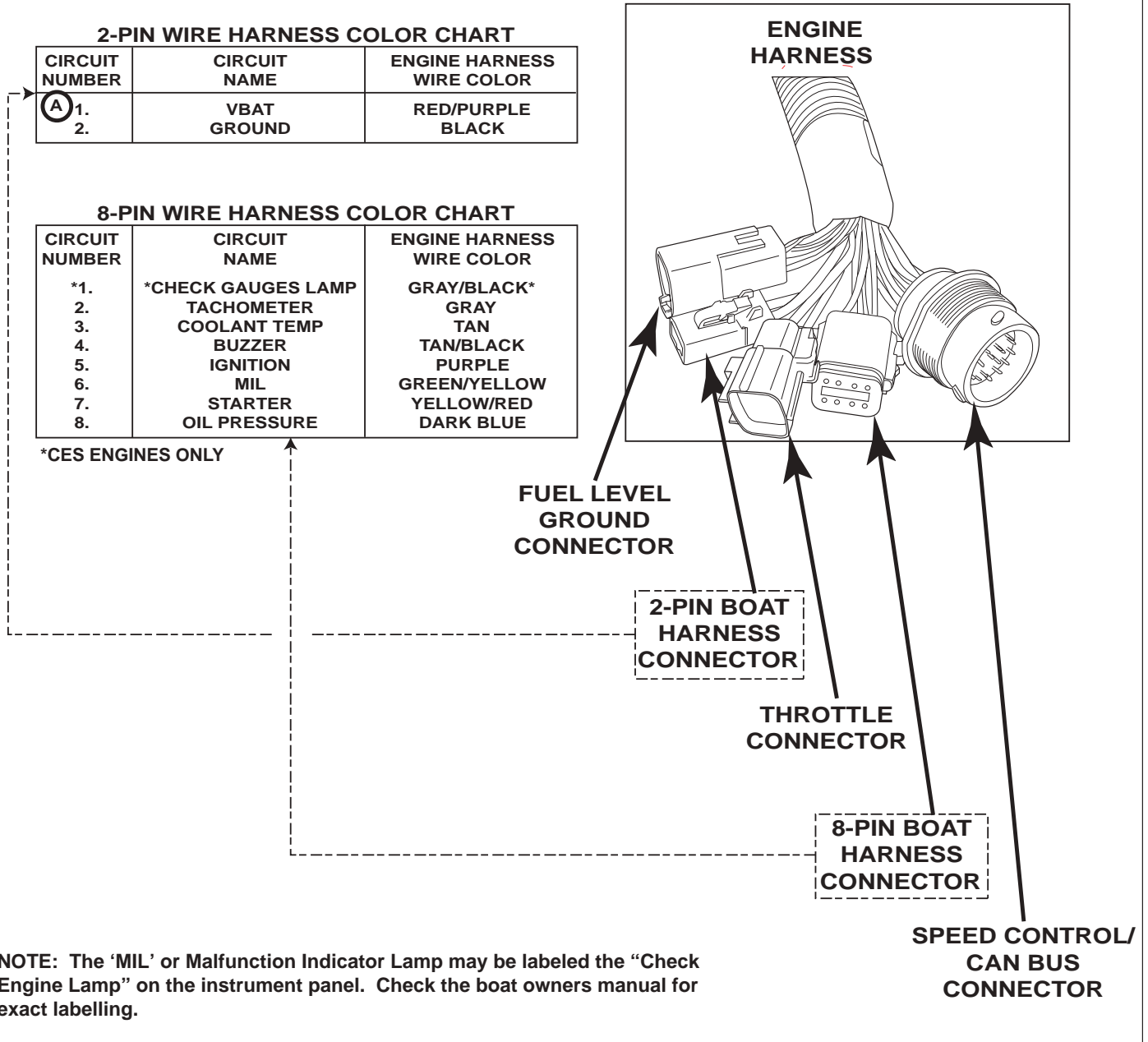

Figure 16-1 Typical Instrumentation Wiring

IMPORTANT: Your engine is designed to work with the standard electronics installed in your boat. If you add other electrical components or accessories, you could change the way the fuel injection controls your engine or the overall electrical system functions. Before adding electrical equipment, consult your dealer. If you don't, your engine may not perform properly.



CAUTION

Add-on equipment may adversely affect the alternator output or overload the electrical system. Any damage caused as a result will not be covered by, and may void, your warranty.

To obtain service and/or parts information for your PCM Marine Engine, contact your servicing or local dealer.

PCM distributes publications through a worldwide dealer network the same way parts and technical support are handled.

FORMS - 19

PCM WARRANTY TRANSFER APPLICATION

The remainder of the original PCM limited warranty is transferable **within thirty (30) days of date of sale** by the original owner/user to a subsequent purchaser for the remainder of the unused portion of the original warranty term, **provided the engine does not have in excess of 500 hours.** The original date of sale or original in-service date (whichever comes first) begins the warranty coverage period.

Direct Sale by Owner/Dealer Promo/Ski Show User/ or First Operator:

The second purchaser can be registered as the owner and retain the unused portion of the warranty term by sending the following:

- Original owner's Warranty Registration Card
- Copy of Bill of Sale/Sales Contract/Operator Contract
- Completed Warranty Transfer Application
- Warranty transfer fee

The fee for transfer is \$200.00. The transfer fee and application must be submitted via certified check **within 30 days of date of sale.**

- Purchasing from a Dealer - If you purchased your boat/engine from a dealer, the dealer may be able to submit both the engine and the boat warranty transfer at the same time through the boat manufacturer.
- Purchasing from an Individual - If you purchased your boat/engine from an individual, you may still be able to submit both the engine and the boat warranty transfer at the same time through the boat manufacturer. If you need to submit the engine warranty transfer only, mail it to the following address:

Pleasurecraft Engine Group
P.O. Drawer 369
Little Mountain, S.C., 29075

- A Warranty Registration Card will be issued to the second owner, reflecting the change has been made in the factory computer.

OUTSIDE THE U.S. AND CANADA, CONTACT YOUR LOCAL PLEASURECRAFT DEALER OR WARRANTY SERVICES AT (803) 345-0050 FOR MORE INFORMATION ON HOW TO APPLY TO THIS PROGRAM.

IMPORTANT! PURCHASER NOTICE: The checks listed below are designed to insure safety and satisfaction. A step-by-step procedure for pre-delivery can be found in Course 1 of the PCM E-Train Program. Therefore, we require the following inspection be performed at your expense by a qualified technician prior to delivery. By signature the technician certifies that he/she has checked the installation and operation of the engine and finds it to be performing properly. All terms in the Limited Warranty located in the Engine Owners Manual still apply.

ENGINE MODEL: _____

ENGINE SERIAL: _____

TRANS. SERIAL: _____

ENGINE HOURS: _____

HULL SERIAL #: _____

Pre-Delivery Checklist

- | | |
|---|---|
| <input type="checkbox"/> Check for Bulletins | <input type="checkbox"/> Belt and Pulley: Inspect for Damage |
| <input type="checkbox"/> Engine Oil: Check | <input type="checkbox"/> All Drain Plugs: Confirm Proper Installation |
| <input type="checkbox"/> Drive Lube: Check | <input type="checkbox"/> All Fuel Lines: Confirm No Leaks |
| <input type="checkbox"/> Battery Rating, Charge, and Level: Check | <input type="checkbox"/> All Oil Lines: Confirm No Leaks |
| <input type="checkbox"/> Control Adjustments: Confirm Proper Operation | <input type="checkbox"/> All Water Lines: Confirm No Leaks |
| <input type="checkbox"/> Gauges: Check for Proper Operation | <input type="checkbox"/> Electrical Wiring: Check for Proper Installation |
| <input type="checkbox"/> Record Propeller Size, Rotation and WOT
WOT RPM _____ Diameter _____ Pitch _____ Rotation _____ | |
| <input type="checkbox"/> Record Fuel Pressure, Idle _____
Record Fuel Pressure, WOT _____ | <input type="checkbox"/> Trouble Codes Checked
Trouble Codes Cleared |
| <input type="checkbox"/> Dealer Reviewed Warranty with Owner | |

DATE OF SALE (2ND Owner) ____/____/____

DATE OF SALE (1st Owner/1st Operator) ____/____/____

(New Owner)

(Previous Owner)

NAME: _____

NAME: _____

ADDRESS: _____

ADDRESS: _____

CITY, STATE, ZIP _____

CITY, STATE, ZIP _____

I hereby certify the pre-delivery checklist on engine # _____ and have corrected any abnormality revealed by this inspection.

(Technician Signature, Dealer & Date)

(Seller's Signature & Date)

(Purchaser's Signature & Date)

PCM

SUMMARY OF WARRANTY TERM LIMITS

This list does not, in any way, modify the official Limited Warranty Statement of PCM. This list has been compiled only as a general outline of year and hour limits imposed on different models of PCM engines. Please review the official Limited Warranty Statements on the following pages for specific terms and limitations as they apply to the particular engine / component involved.

ENGINE MODEL YEAR:

WARRANTY COVERAGE TERM:

2016

5 years, 500 hours. 5 years, 500 hours Transmission

Base Engine

1 year, 200 hours with exclusions.

Note:

*** The remainder of the original PCM limited warranty is transferable to a subsequent purchaser, provided the engine **does not have in excess of 500 hours and is submitted to PCM within 30 days of the date of sale.**

PCM OWNERSHIP CHANGE NOTICE

If you are the new owner of a Pleasurecraft Marine Engine on which the warranty has expired and would like to inform Pleasurecraft of your ownership for notification purposes in case of Service Updates, Recalls, etc., complete the section below and return by mail to PCM. PO Drawer 369, Little Mountain, SC 29075.

ENGINE MODEL: _____

ENGINE SERIAL NUMBER: _____

TRANS. MODEL: _____

TRANS. SERIAL NUMBER: _____

(New Owner) NAME: _____

ADDRESS: _____

CITY,STATE,ZIP: _____

DATE OF PURCHASE: _____

(Previous Owner)NAME: _____

ADDRESS: _____

CITY,STATE,ZIP: _____



PROBLEM NOTIFICATION OR INFORMATION REQUEST FORM

IMPORTANT: All blanks MUST be completed to insure proper identification of your engine which is necessary to properly understand your request.

When completed, mail this form to:

Pleasurecraft Marine
PO Drawer 369
Little Mountain, SC 29075

Engine Model _____ Engine Serial Number _____ Gear Serial Number _____

Owner Information

Name _____ Telephone () _____

Address _____

City _____ State _____ Zip _____

Selling Dealer _____

Dealers Address _____

Date of Purchase _____ Boat Make _____ Length _____ Type _____

Gentlemen, I would like to inform you of a problem I have experienced with the above engine. My problem is:

Multiple horizontal lines for writing the problem description.

My boat is located at _____

Address _____ Telephone () _____

City _____ State _____ Zip _____

Requestors Signature _____ Date _____



From: _____

FIRST
CLASS
POSTAGE

MAIL TO:

WARRANTY DEPARTMENT
PLEASURECRAFT ENGINE GROUP
P.O. DRAWER 369
LITTLE MOUNTAIN, SC 29075

**This Page
Was Intentionally
Left Blank**

Pleasurecraft Engine Group 1737 Highway 76 East, Little Mountain SC 29075

<https://www.boat-manuals.com/>