

 FOUR WINNS®

# V SERIES

OWNERS MANUAL

090-3065 A



## WARNING

A wide variety of components used on this vessel contain or emit chemicals known to the State of California to cause cancer and birth defects and other reproductive harm.

### EXAMPLES INCLUDE:

- Engine and generator exhaust
- Engine and generator fuel, and other liquids such as coolants and oil, especially used motor oil
- Cooking fuels
- Cleaners, paints, and substances used for vessel repair
- Waste materials that result from wear of vessel components
- Lead from battery terminals and from other sources such as ballast or fishing sinkers

### TO AVOID HARM:

- Keep away from engine, generator, and cooking fuel exhaust fumes
- Wash areas thoroughly with soap and water after handling the substances above

GM2203301

## Boating Safety Checklist

### MUST HAVE ITEMS As Required By Regulation

#### Personal Flotation Devices (Life Jackets)

- Type I, II, III, or V for **each person onboard** (Wearable)
- One Type IV (Throwable)  
Not Required on Non-Powered boats under 16'

#### Fire Extinguishers

Choose One	Boats w/out Fixed System	- OR -	Boats w/ Fixed System
<input type="checkbox"/> Boats <26'	1 Size BI		Fixed System
<input type="checkbox"/> Boats 26 - <40'	2 Size BI*		Fixed System + 1 Size BI
<input type="checkbox"/> Boats 40 - 65'	3 Size BI*		Fixed system + 2 Size BI*

\* One Size BII may be substituted for Two Size BI Extinguishers

#### Visual Distress Signals (VDS)

- Choose One
- Combination Day/Night VDS (Flares or Flare Gun)
  - Daytime VDS (Flags, Smoke Signal)  
AND  
Nighttime VDS (Automated SOS Light)

#### Sound Signals

- Horn or Whistle
- Bell (Not required for vessels under 12m)

#### Ventilation (Boats with Gasoline Systems)

- Natural Ventilation
- Powered Ventilation

#### Backfire Flame Control

- Backfire Flame Arrestor (Gasoline Engines except outboards)

- The above represents minimum USCG Safety Requirements on-board vessels.
- Other Requirements may be necessary to comply with state laws.
- This is not intended to be an all-inclusive list but rather a baseline of items to make your boating adventure safe and fun.
- For Vessels over 65' refer to 33CFR 25.30-20 or ABYC A-4.



## Boating Safety Checklist

### Recommended Items

Items in Red May be Required in Some States

#### Boats on Inland Waters Everything on Required List PLUS:

- |   |  |
|---|--|
| <input type="checkbox"/> <b>First Aid Kit</b><br><input type="checkbox"/> <b>Anchor with Sufficient Line</b><br><input type="checkbox"/> Bailing Device<br><input type="checkbox"/> Sun Protection<br><input type="checkbox"/> Alternate Propulsion (Paddles, Oars) | <input type="checkbox"/> <b>Boating Safety Education/<br/>Certificate</b><br><input type="checkbox"/> <b>Watersports Flag<br/>(Skier Down/Diver Down Flag)</b> |
|---|--|

#### Boats on Nearshore Waters Everything Above PLUS:

- |  |  |
|--|--|
| <input type="checkbox"/> Extra Food & Water<br><input type="checkbox"/> Float Plan<br><input type="checkbox"/> Compass<br><input type="checkbox"/> VHF Radio | <input type="checkbox"/> GPS/Chartplotter<br><input type="checkbox"/> Depth Finder<br><input type="checkbox"/> Charts<br><input type="checkbox"/> Spare Tool Kit |
|--|--|

#### Boats on Offshore Waters Everything Above PLUS:

- |   |   |
|---|---|
| <input type="checkbox"/> EPIRB<br><input type="checkbox"/> Life Raft<br><input type="checkbox"/> Searchlight<br><input type="checkbox"/> List of CPR Instruction<br><input type="checkbox"/> Radar<br><input type="checkbox"/> Radar Reflector<br><input type="checkbox"/> Shore Landing Craft (Tender) | <input type="checkbox"/> Man-Overboard Recovery Gear<br><input type="checkbox"/> AIS<br><input type="checkbox"/> Sea Drogue<br><input type="checkbox"/> Safety Knife<br><input type="checkbox"/> Weather Information System<br><input type="checkbox"/> Radio Direction Finder<br><input type="checkbox"/> Long Range Communications Gear |
|---|---|

#### Boats on River Waters Everything on Required List Plus:

- |                                    |                                 |
|------------------------------------|---------------------------------|
| <input type="checkbox"/> Throw Bag | <input type="checkbox"/> Helmet |
|------------------------------------|---------------------------------|

#### Miscellaneous Items Other Items That May be Recommended:

- |   |   |
|---|---|
| <input type="checkbox"/> Heaving Line<br><input type="checkbox"/> Spare Keys<br><input type="checkbox"/> Boat Hook/Pole<br><input type="checkbox"/> Spare Propeller<br><input type="checkbox"/> Extra Engine Oil<br><input type="checkbox"/> Handheld Lead-line | <input type="checkbox"/> Strobe Light<br><input type="checkbox"/> Carbon Monoxide Detector<br><input type="checkbox"/> Extra Clothing<br><input type="checkbox"/> Marine Hardware<br><input type="checkbox"/> Masks & Fins (For Clearing Props)<br><input type="checkbox"/> Storm Sails |
|---|---|

Scan here to download  
the ABYC Boating Safety  
Checklist App  
[abycinc.org/mobileapps](http://abycinc.org/mobileapps)



<b>PREFACE</b> .....	11
<b>SAFETY MESSAGES</b> .....	12
<b>OPERATION</b> .....	18
A - 1 GENERAL .....	18
A - 2 COMPONENT SYSTEMS .....	18
A - 3 SAFETY EQUIPMENT .....	18
A - 4 PASSENGER SAFETY .....	18
A - 5 RULES OF THE ROAD .....	18
A - 6 LIGHTNING .....	18
A - 7 DRUGS AND ALCOHOL .....	19
A - 8 PRE-CRUISE SYSTEM CHECK .....	19
A. Before Starting the Engines .....	19
B. After Starting the Engine .....	19
A - 9 ENGINE OPERATIONAL PROCEDURES .....	20
A. Before Starting .....	20
B. Cold/Warm Engine Start - EFI & Diesel .....	20
C. Starting Procedures for Diesel Engines with Volvo Penta Electronic Vessel Control (EVC) .....	21
D. Shifting and Control Speed .....	22
E. Stopping Engine - EFI & Diesel .....	23
F. Stopping Engine for Diesel Engines with Volvo Penta Electronic Vessel Control (EVC) .....	23
G. After Stopping Engine(s) .....	24
A - 10 GROUNDING AND TOWING .....	24
A - 11 BOATING EDUCATION .....	24
A. Boating Courses .....	24
B. Boating Manuals or Literature .....	25
C. Charts and Maps .....	25
D. Laws and Regulations .....	25
A - 12 BOAT OWNER REGISTRATION .....	25
A - 13 ACCIDENT REPORTING .....	26
A - 14 DISCHARGE OF OIL .....	26
A - 15 DISPOSAL OF PLASTICS & OTHER GARBAGE .....	26
A - 16 MARPOL TREATY .....	26
<b>BOATING SAFETY</b> .....	28
B - 1 GENERAL .....	28
A. Required Safety Equipment .....	28
B. Personal Flotation Devices (PFDs) .....	28
C. PFD Types .....	28
D. PFD Pointers .....	29
E. Fire Extinguisher .....	29
F. Fire Extinguisher System .....	30
G. Visual Distress Signal Devices .....	30
H. Sound Signaling Devices .....	31
I. Navigation Lights .....	31
J. Additional Recommended Equipment .....	31
B - 2 CARBON MONOXIDE .....	31
A. Properties and Characteristics of Carbon Monoxide .....	32
B. What Makes Carbon Monoxide .....	32
C. How a Person is Affected by Carbon Monoxide .....	32
D. Effects of Carbon Monoxide .....	32

E. Symptoms.....	32
F. Treatment (Evaluate, Ventilate, Evacuate, Investigate, Take Corrective Action).....	33
G. Inspection.....	33
H. Operation.....	33
I. Boathouses, Sea Walls and Confined Spaces.....	33
J. The Effect of Boats Moored Along Side.....	34
K. Backdrafting (Station Wagon Effect).....	34
L. Accumulation of Exhaust Gases - Swim Platform.....	35
M. Dangerous Activity - “Teak Surfing”/“Dragging”.....	35
N. Cabin Appliances.....	35
O. Air Conditioning (Applicable Models Only).....	35
P. Ventilation of Accommodation (Occupied) Spaces.....	35
Q. Running of Engines in Idle.....	35
R. Altitude and Sea Conditions.....	35
S. Portable Generator Sets.....	36
T. Maintenance - Engine Performance.....	36
U. Maintenance - External Conditions.....	36
V. Maintenance - Exhaust System Integrity.....	36
W. Maintenance - Ventilation Systems.....	37
X. Maintenance - Bulkhead and Deck Integrity.....	37
Y. Maintenance - Air Conditioning Systems (Applicable Models Only).....	37
Z. Maintenance - Liquid Drains.....	37
AA. Carbon Monoxide Detection Systems.....	37
<b>B - 3 SAFE BOATING PRACTICES.....</b>	<b>38</b>
A. Drugs and Alcohol.....	38
B. Safe Operation.....	38
C. Passenger Safety.....	38
D. Propeller.....	39
E. First Aid.....	39
F. Operation By Minors.....	39
G. “Rules of the Road”.....	39
H. Voluntary Inspections.....	39
I. Safe Boating Courses.....	39
<b>B - 4 WATER SPORTS.....</b>	<b>40</b>
A. Water Sport Guidelines.....	40
B. Water Skiing/Wakeboarding/Kneeboarding.....	40
<b>B - 5 HYPOTHERMIA.....</b>	<b>42</b>
<b>BASIC SEAMANSHIP.....</b>	<b>43</b>
<b>C - 1 GENERAL.....</b>	<b>43</b>
A. Boating Regulations.....	43
B. Rules of Seamanship.....	43
<b>C - 2 NAVIGATIONAL AIDS.....</b>	<b>45</b>
A. International Association of Lighthouse Authorities System B (IALA-B).....	45
B. Lateral Markers.....	45
C. Safe Water Markers.....	45
D. The Uniform State Waterway Marking System.....	46
E. A Special Sign.....	46
F. Noise.....	46
<b>C - 3 ANCHORING.....</b>	<b>46</b>
<b>C - 4 RECOMMENDED READING.....</b>	<b>47</b>
<b>C - 5 CONTACTS.....</b>	<b>47</b>
<b>C - 6 OWNER’S LOGS AND RECORDS.....</b>	<b>48</b>

C - 7	NAVIGATIONAL AIDS CHART .....	48
<b>WARRANTY AND SERVICE.....</b>		<b>49</b>
D - 1	FOUR WINNS WARRANTY POLICY .....	49
D - 2	DECK/HULL STRUCTURE WARRANTY .....	49
D - 3	WARRANTY REGISTRATION .....	49
D - 4	TRANSFER OF WARRANTY .....	49
D - 5	PRE-OWNED UNIT REGISTRATION .....	49
D - 6	INSURANCE COVERAGE .....	50
D - 7	SERIAL NUMBER RECORD.....	50
D - 8	PRE-DELIVERY SERVICE.....	50
D - 9	REPLACEMENT PARTS.....	50
D - 10	OWNER'S RESPONSIBILITIES.....	50
D - 11	CONSTRUCTION STANDARDS.....	51
D - 12	WINNGEAR.....	51
	NAME/ADDRESS CHANGE FORM .....	53
	WARRANTY REGISTRATION TRANSFER REQUEST .....	55
<b>ENGINES, DRIVES AND INSTRUMENTATION.....</b>		<b>57</b>
E - 1	GENERAL.....	57
E - 2	ENGINE EXHAUST.....	57
	A Carbon Monoxide.....	57
	B Carbon Monoxide Monitors .....	58
E - 3	ENGINES & DRIVE SYSTEM .....	59
	A Engine.....	59
	B. Stern Drives .....	59
	C. Volvo Penta IPS Drive - Units.....	59
E - 4	PROPELLERS .....	59
	A. Diameter .....	59
	B. Pitch.....	60
	C. Prop Slip .....	60
E - 5	ENGINE COOLING SYSTEMS .....	60
	A. Raw Water Cooling .....	60
	B. Fresh Water Cooling .....	61
E - 5	RUNNING ANGLE & POWER TRIM/TILT .....	61
	A. Power Trim.....	62
	B. Power Tilt.....	62
E - 7	TRIM TABS .....	62
	A. Control Listing .....	63
	B. Induce Planning & Controlling Trim Angle .....	63
	C. Trim Tab Maintenance .....	64
E - 8	ENGINE INSTRUMENTATION .....	64
	A. Tachometer/Hour Meter Combination Gauge.....	64
	B. Speedometer .....	65
	C. Temperature Gauge.....	66
	D. Oil Pressure Gauge.....	66
	E. Voltmeter.....	66
	F. Fuel Gauge .....	66
	G. Power Trim Gauge .....	66
	H. Gas Vapor Detector .....	66
	I. Engine Hour Meter .....	66
	J. Three Position Ignition Switch .....	66

K.	Four Position Ignition Switch .....	67
L.	Emergency Stop Switch .....	67
M.	Alarm Systems .....	67
N.	Navigational Equipment .....	68
E - 9	INSTRUMENT MAINTENANCE .....	69
<b>CONTROL SYSTEMS .....</b>		<b>70</b>
F - 1	GENERAL .....	70
F - 2	CONTROL OPERATION .....	70
A.	General .....	70
B.	Shifting and Control Speed .....	71
C.	Engine Speed Synchronization .....	72
F - 3	NEUTRAL SAFETY SWITCH .....	72
F - 4	JOYSTICK CONTROL .....	72
F - 5	CONTROL SYSTEM MAINTENANCE .....	73
<b>STEERING SYSTEMS.....</b>		<b>74</b>
G - 1	GENERAL .....	74
A.	Rotary Steering .....	74
B.	Power Steering - Stern Drive .....	74
C.	Electronic Vessel Control (EVC).....	75
D.	Tilt Steering.....	75
G - 2	STEERING LOAD .....	76
G - 3	PROPELLER TORQUE .....	76
G - 4	STEERING SYSTEM MAINTENANCE.....	76
<b>ELECTRICAL SYSTEMS .....</b>		<b>78</b>
H - 1	GENERAL .....	78
H - 2	SINGLE ENGINE - DUAL BATTERY SYSTEM .....	78
A.	Installation .....	79
B.	Battery Switch Operation.....	79
H - 3	DUAL ENGINE - TRIPLE BATTERY SYSTEM.....	80
A.	Installation .....	80
B.	Dual Switch Battery Panel.....	80
C.	Battery Switch Operation.....	81
H - 4	CIRCUIT BREAKER PANELS .....	83
H - 5	BATTERY CHARGER .....	85
H - 6	12VDC VOLTMETER .....	85
H - 7	12 VOLT ELECTRICAL EQUIPMENT .....	86
A.	Helm Equipment.....	86
B.	Installation of Additional 12 Volt Equipment .....	88
C.	Interior/Exterior Equipment .....	89
H - 8	12 VOLT ELECTRICAL SYSTEM SHUTDOWN PROCEDURES.....	90
H - 9	120 & 240/120 VOLT ELECTRICAL SYSTEMS .....	91
H - 10	DOCKSIDE OPERATION .....	93
A.	Shore Power Connections .....	93
B.	120 Volt AC Equipment .....	95
C.	Reverse Polarity Indicator .....	96
D.	Ground Fault Current Interrupters (GFCI).....	97
H - 11	GENERATOR .....	97
H - 12	ELECTRICAL SYSTEM MAINTENANCE .....	99



	A. Battery Maintenance .....	99
	B. Electrical Wiring Maintenance .....	100
H - 13	STRAY CURRENT CORROSION .....	100
	A. General .....	100
	B. Galvanic Corrosion .....	100
	C. Corrosion Prevention .....	101
<b>FUEL SYSTEMS .....</b>		<b>106</b>
I - 1	FUEL SYSTEMS .....	106
	A. Gasoline Fuel System .....	106
	B. System Testing .....	108
	C. Fuel Fills .....	108
	D. Fuel Vent (P-trap).....	109
	E. Anti-Syphon Valve.....	109
	F. Fuel Gauge .....	110
	G. Fuel Sender .....	110
	H. Fuel Filters .....	110
	I. Gas Vapor Detector .....	110
	J. Use and Maintenance .....	111
I - 2	DIESEL FUEL SYSTEMS - TWIN .....	111
	A. System Testing .....	112
	B. Fuel Fills.....	112
	C. Fuel Vents.....	112
	D. Fuel Pick-up .....	113
	E. Fuel Level .....	113
	F. Fuel Sender .....	113
	G. Fuel Filters .....	114
	H. Use and Maintenance .....	114
I - 3	FUEL STANDARDS .....	115
	A. Problems with Alcohol in Gasoline .....	115
	B. Recommendations .....	115
I - 4	FUELING INSTRUCTIONS .....	115
<b>WATER AND WASTE SYSTEMS .....</b>		<b>118</b>
J - 1	GENERAL .....	118
J - 2	DISINFECTING THE FRESH WATER SYSTEM.....	119
J - 3	PRESSURIZED WATER SYSTEM.....	120
	A. Priming the System .....	120
	B. System Operation .....	120
	C. Water Heating Systems.....	120
	D. Using the Shower .....	121
J - 4	GRAY WATER SYSTEM.....	122
J - 5	SHORE WATER CONNECTION .....	122
J - 6	TRANSOM SHOWER .....	123
J - 7	WASTE SYSTEM.....	123
	A. Porcelain Head.....	123
	B. Electric Toilet Operation .....	124
	C. VacuFlush® Sanitation System .....	125
	D. Tecma® Sanitation System .....	126
	E. Head with Overboard Discharge .....	127
	F. Dockside Waste Pump Out .....	128
J - 8	SYSTEM MAINTENANCE.....	129

A. Clean Vents and Screens.....	129
B. Winterizing the Water System .....	129
C. Winterizing the Waste System .....	130
<b>VENTILATION AND DRAINAGE SYSTEMS .....</b>	<b>131</b>
K - 1 ENGINE COMPARTMENT VENTILATION.....	131
A. Natural Ventilation System .....	131
B. Forced Air Ventilation .....	131
C. Engine Ventilation System Maintenance .....	131
K - 2 CABIN VENTILATION .....	131
K - 3 HULL DRAINAGE SYSTEMS.....	132
A. Transom Drain .....	132
B. Bilge Pumps .....	132
C. Sump .....	132
D. Bilge Compartment Drainage .....	133
E. Cockpit Drainage .....	133
<b>INTERIOR EQUIPMENT.....</b>	<b>134</b>
L - 1 GALLEY EQUIPMENT .....	134
A. Electric Cooktop or Stove.....	134
B. Microwave Oven .....	134
C. Refrigerator .....	134
L - 2 CABIN EQUIPMENT .....	135
A. Dinette Table.....	135
B. Carbon Monoxide Detectors.....	135
L - 3 ENTERTAINMENT .....	135
A. Stereo System .....	136
B. TV and DVD Player.....	136
L - 4 AIR CONDITIONING .....	136
<b>EXTERIOR EQUIPMENT .....</b>	<b>138</b>
M - 1 RAILS & DECK HARDWARE .....	138
M - 2 TRANSOM DOOR.....	138
M - 3 COMPANIONWAY DOOR.....	139
M - 4 WINDOWS .....	139
A. Windshield .....	139
B. Cabin/Cockpit Windows .....	140
M - 5 FOREDECK HATCH .....	140
M - 6 COCKPIT REFRESHMENT CENTER or COCKPIT GALLEY .....	141
M - 7 COCKPIT TABLE w/MOUNT.....	142
M - 8 AFT SWIM PLATFORM.....	142
M - 9 EXTENDED SWIM PLATFORM LIFT .....	143
M - 10 TRANSOM STORAGE LOCKER .....	143
M - 11 ELECTRIC GRILL .....	144
M - 12 TRANSOM TABLE .....	145
M - 13 BOW PLATFORM .....	145
M - 14 WINDLASS.....	145
M - 15 SPOT/FLOOD LIGHT.....	146
M - 16 UNDERWATER LIGHTING .....	146
M - 17 HARD TOP.....	146
M - 18 ENGINE HATCH w/ ELECTRIC LIFT .....	147

M - 19	FLAG POLE AND HOLDER .....	148
<b>UPHOLSTERY .....</b>		<b>149</b>
N - 1	INTERIOR FURNISHINGS.....	149
	A. Couch .....	149
	B. V-berth or Forward Cabin.....	149
	C. Mid Cabin.....	151
	D. Mid Cabin Stateroom .....	151
N - 2	EXTERIOR FURNISHINGS.....	152
	A. Helm Seat .....	152
	B. L-Shaped Stern Seating.....	153
	C. U-Shaped Stern Seating .....	153
	D. Opposing Bench Seats - Cockpit.....	154
	E. Port Lounge .....	154
	F. Swim Platform Seat.....	154
	G. Deck Sunpads.....	155
N - 3	INTERIOR UPHOLSTERY CARE .....	155
	A. Cleaning Interior Fabric/Upholstery .....	155
	B. Interior Carpets .....	156
	C. Privacy Curtains.....	156
N - 4	EXTERIOR UPHOLSTERY CARE .....	156
	A. Cleaning Vinyl .....	156
	B. Exterior Carpets .....	158
	C. Cleaning and Maintenance.....	158
	D. Stain Removal Testing .....	159
	E. Stain Removal Procedures.....	159
N - 5	REPLACEMENT UPHOLSTERY .....	159
<b>WEATHER COVERS.....</b>		<b>160</b>
O - 1	GENERAL INFORMATION .....	160
O - 2	GENERAL CANVAS INSTALLATION GUIDELINES .....	160
O - 3	BIMINI TOP .....	161
	A. Bimini Top without Hardtop .....	161
	B. Bimini Top with Hardtop .....	161
O - 4	CAMPER CANVAS .....	162
O - 5	COCKPIT COVER.....	163
O - 6	OTHER CANVAS INSTALLATION .....	164
O - 7	USE OF WEATHER COVERS AND CARBON MONOXIDE .....	166
O - 8	WINTER STORAGE.....	167
O - 9	MAINTENANCE .....	167
<b>FIBERGLASS AND HULL.....</b>		<b>169</b>
P - 1	HULL DESIGN INFORMATION.....	169
P - 2	FIBERGLASS CONSTRUCTION .....	169
P - 3	EQUIPMENT INSTALLATION.....	169
P - 4	FIBERGLASS CARE & MAINTENANCE .....	169
	A. General Maintenance.....	169
	B. Weathering Effects on Gel Coat .....	170
	C. Stains.....	171
P - 5	FIBERGLASS REPAIRS .....	171
	A. Scratches .....	171

	B. Gouges & Cracks.....	172
	C. Osmotic Blistering .....	172
P - 6	ANTI-FOULING PAINT.....	173
P - 7	HULL SUPPORT.....	173
<b>WOODWORK AND COMPOSITES.....</b>		<b>175</b>
Q - 1	HIGH-PRESSURE LAMINATE CARE .....	175
Q - 2	REAL WOOD TRIM.....	175
Q - 3	STAR BOARD.....	175
Q - 4	LAMINATED FIBERGLASS.....	175
Q - 5	TEAK.....	176
Q - 6	SOLID SURFACE MATERIAL.....	176
Q - 7	ACRYLIC PLASTIC - (PLEXIGLASS).....	177
Q - 8	AQUA FLEX SWIM PLATFORM MAT.....	178
Q - 9	FLEXITEEK.....	178
<b>GENERAL MAINTENANCE.....</b>		<b>179</b>
R - 1	WINTERIZATION .....	179
	A. Prior to Lifting for Winter Lay up .....	179
	B. After Lifting.....	179
	C. Prior to Winter Storage.....	180
R - 2	GENERAL MAINTENANCE SCHEDULE .....	181
<b>TRAILER INFORMATION.....</b>		<b>184</b>
S - 1	GENERAL TRAILER INFORMATION .....	184
	A. Regulations.....	184
	B. Load Carrying Capacity.....	184
	C. Hitches.....	185
S - 2	TRAILER COMPONENTS.....	185
	A. Bunk Supports .....	185
	B. Tongue.....	186
	C. Swivel Jack .....	186
	D. Surge Brakes & Coupling Assembly.....	187
	E. Winch.....	188
	F. Tires & Wheels.....	188
	G. Spare Tire Carrier .....	189
	H. Lights .....	189
	I. Tie-downs .....	189
S - 3	OPERATION .....	191
	A. Hitching Trailers .....	191
	B. Backing Up with Surge Brakes .....	193
S - 4	TRAILERING .....	194
	A. Checklist .....	194
	B. Tactics .....	195
S - 5	MAINTENANCE .....	195
	A. Care of Exterior Finish.....	195
	B. Bunks.....	195
	C. Swivel Jack .....	196
	D. Brake Actuator & Coupling Assembly.....	196
	E. Winch.....	196

	F. Lights .....	196
	G. Tie-downs .....	196
	H. Wheels.....	196
	I. Brakes.....	196
	J. Bearings.....	197
S - 6	AXLE INSPECTION & REPAIRS.....	198
	A. Removal of Hub .....	198
	B. Bearing/Seal Inspection and Replacement.....	198
	C. Hub Reinstallation .....	199
S - 7	SUPPLEMENTAL TRAILER INFORMATION .....	199
	A. Information Contained on Sidewall of the Tire .....	199
	B. Sample Tire Registration.....	200
	C. Inflating Your Tires .....	200
	D. Load Carrying Capacity.....	201
	E. Reporting Safety Defects .....	201
	F. Glossary of Tire Terminology .....	202
<b>PRE-LAUNCH AND UNDERWAY.....</b>		<b>203</b>
T - 1	LAUNCH & CRUISE CHECKLIST .....	203
T - 2	FUELING.....	204
	A. Recommendations .....	204
	B. Preliminary Guidelines .....	204
	C. Pumping Fuel.....	204
	D. After Fueling.....	204
T - 3	LOADING PASSENGERS & GEAR .....	205
T - 4	STARTING PROCEDURES .....	205
	A. Preliminary Checks .....	205
	B. Starting.....	205
T - 5	MANEUVERING.....	206
	A. Leaving the Dock .....	206
	B. Stopping.....	206
T - 6	ACCELERATION.....	207
T - 7	TRIMMING YOUR BOAT .....	207
T - 8	NAVIGATION LIGHTS.....	208
T - 9	HAZARDOUS CONDITIONS.....	209
	A. Storms .....	209
	B. Fog.....	209
	C. Running Aground .....	209
	D. Warning Markers.....	210
T - 10	REACTING TO EMERGENCIES .....	210
	A. Flooding .....	210
	B. Capsizing and Man Overboard.....	210
	C. Capsizing .....	210
	D. Man Overboard .....	210
	E. Collision .....	211
	F. Fire.....	211
	G. Medical Emergency.....	211
	H. Propulsion Failure .....	211
	I. Control Failure.....	212
	J. Steering Failure.....	212
	K. Additional Underway Information.....	213
T - 11	RETURNING TO SHORE.....	213
	A. Docking.....	213

---

B. Mooring.....	213
<b>GLOSSARY.....</b>	<b>215</b>
<b>FLOAT PLAN.....</b>	<b>222</b>
<b>FUEL LOG.....</b>	<b>223</b>
<b>SERVICE LOG.....</b>	<b>226</b>
<b>SERVICE INFORMATION.....</b>	<b>229</b>

Congratulations on your new boat purchase and welcome to our boating family!

We want your boating experience to be the most enjoyable possible. The more you know about your new boat, the more you'll enjoy the time you spend aboard. That's why we prepared this manual. It's your guide for safe operation as well as understanding your boat's systems and equipment. It has been written for the beginning boater but experienced boaters will find helpful information as well. Be sure to read the contents thoroughly.

This manual will acquaint you with the use and maintenance of your new Four Winns boat. This manual also provides special information critical to the safety of the passengers, and longevity of the equipment. The information on the following page lists the graphics used to increase the visibility of these important messages. Also included in your owner's packet is the "Boating Basics, A Guide to Responsible Boating". This guide covers boating basics and should be read along with your Four Winns owner's manual before operating your boat. Review this information completely before using your new boat. **Please refer to our website for further updated information and possible revisions to this manual.**

Four Winns continually strives to improve its products. Unit specifications, including standard and optional equipment are constantly being modified. **Equipment availability is also subject to change without notice. The most current and accurate information available at the time of publication is included in this manual. Some variation in material, equipment, description, location, and details can result.**

The information in this manual focuses upon the equipment designed and manufactured by Four Winns on specific models. When appropriate, please utilize the information pertinent to your specific boat model.

Equipment such as engines, and other accessories are manufactured by others. **The information provided in this manual is intended to be used in conjunction with the information provided by the manufacturers of this equipment.** All information available at the time of manufacture has been included with your owner's packet. In many cases, replacement of manufacturer's literature may be obtained via their respective websites.

**Read this entire manual carefully before operating your new boat.** Many instructions may require direct performance of the activity to fully understand the correct method. If you choose to read this manual at home, remember to take it to the boat with you.

Your Four Winns dealer knows your boat best and is committed to your complete satisfaction. Return to the dealer for service or other assistance. If you find it necessary to contact Four Winns directly, please refer to the contact information listed below. Be sure to include the boat model, hull identification number, your daytime telephone number, and specifics of the information desired.

This manual has been specifically developed for the V series models. Please record the model and hull identification number information below.

Model

Hull Identification Number

---

This manual should be considered part of the boat. Should you sell the boat, pass this manual on to the new owner. Take special care of this manual. Certain information in this manual may not be available in a replacement manual. An electronic version of this manual may be viewed on our website at [www.fourwinns.com](http://www.fourwinns.com).

Thank you for joining the Four Winns family. We appreciate your purchase and welcome the opportunity to demonstrate our commitment to you.

**Four Winns Customer Service Department**

**925 Frisbie Street**

**Cadillac, Michigan 49601**

**231 775-1343 (Phone)**

**231 779-2345 (Fax)**

**E-mail Address: [boating@fourwinns.com](mailto:boating@fourwinns.com)**

**©Rec Boat Holdings, LLC 2016 All Rights Reserved.**

The popularity of boating and other water sports has grown tremendously in the past few years. Because of this, safety is an important issue for everyone who shares our waterways.

Remember that along with the freedom and exhilaration of boating comes the responsibility that you have for the safety of your passengers and the other boaters who share the water with you. Throughout this manual, specific precautions and symbols identify safety-related information. Be sure to pay close attention to them.

**IMPORTANT HEALTH AND SAFETY INFORMATION ABOUT YOUR NEW BOAT**
**NOTICE**

*Boxes that are gray require your special attention. Notice boxes include helpful boating practices and law reminders.*



*This symbol means “pay attention!” Here is important information for your safety. If you don’t follow these instructions, you can damage your boat, hurt yourself or someone else or, even worse, have a fatal accident.*



*This symbol and signal word indicate a potentially hazardous situation. If you ignore this safety message, property damage or minor or moderate personal injury MAY or CAN result.*



*This symbol and signal word indicate a potential hazard. If you ignore this safety message, serious injury or death CAN result.*



*This symbol and signal word indicates an immediate hazard. If you ignore this safety message, serious personal injury or death WILL result.*

The precautions in this manual can not and do not cover every boating situation. If a specific method or procedure is not recommended, you must make sure that what you do is safe for you and others. Always use common sense when boating! Remember to make sure that every safe boating excursion is a happy experience.

**IMPORTANT HEALTH AND SAFETY INFORMATION ABOUT YOUR NEW BOAT**

WARNING

A wide variety of components used on this vessel contain or emit chemicals known to the State of California to cause cancer and birth defects and other reproductive harm.

**EXAMPLES INCLUDE:**

- Engine and generator exhaust
- Engine and generator fuel, and other liquids such as coolants and oil, especially used motor oil
- Cooking fuels
- Cleaners, paints, and substances used for vessel repair
- Waste materials that result from wear of vessel components
- Lead from battery terminals and from other sources such as ballast or fishing sinkers

**TO AVOID HARM:**

- Keep away from engine, generator, and cooking fuel exhaust fumes
- Wash areas thoroughly with soap and water after handling the substances above

© 2012 Four Winns  
4W000001




We'd also like to remind you to be kind to our environment while you're boating. Don't throw garbage and other refuse overboard. Do your best to keep harmful compounds like gasoline, oil and antifreeze out of the water. Please see the notifications below:

### DISCHARGE OF OIL PROHIBITED

THE FEDERAL WATER POLLUTION CONTROL ACT PROHIBITS THE DISCHARGE OF OIL OR OILY WASTE INTO OR UPON THE NAVIGABLE WATERS OF THE UNITED STATES, OR THE WATERS OF THE CONTIGUOUS ZONE, OR WHICH MAY EFFECT NATURAL RESOURCES BELONGING TO, APPERTAINING TO, OR UNDER THE EXCLUSIVE MANAGEMENT AUTHORITY OF THE UNITED STATES, IF SUCH DISCHARGE CAUSES A FILM OR DISCOLORATION OF THE SURFACE OF THE WATER OR CAUSES A SLUDGE OR EMULSION BENEATH THE SURFACE OF THE WATER. VIOLATORS ARE SUBJECT TO SUBSTANTIAL CIVIL PENALTIES AND/OR CRIMINAL SANCTIONS INCLUDING FINES AND IMPRISONMENT.

*Oil Discharge Plate - (Specific Models Only - Location Not Shown)*

**It is illegal for any vessel to dump plastic trash anywhere in the ocean or navigable waters of the United States. Annex V of the MARPOL TREATY is an international law for a cleaner, safer marine environment. Violation of these requirements may result in civil penalty up to \$25,000, fine and imprisonment.**

 <b>U.S. Lakes, Rivers, Bays, Sounds and 3 miles from shore</b> <b>ILLEGAL TO DUMP Plastic &amp; Garbage</b> Paper Metal Rags Crockery Glass Dunnage Food	<b>3 to 12 miles</b> <b>ILLEGAL TO DUMP Plastic</b> Dunnage, lining & packing materials that float, also if not ground to less than one inch: Paper Crockery Rags Metal Glass Food	<b>12 to 25 miles</b> <b>ILLEGAL TO DUMP Plastic</b> Dunnage, lining & packing materials that float	<b>Outside 25 miles</b> <b>ILLEGAL TO DUMP Plastic</b>
---	---	---	---

State and local regulations may further restrict the disposal of garbage.

*Trash Overboard Decal - (Specific Models Only - Location Not Shown)*

*This manual has been compiled to help you operate your boat with safety and pleasure. It contains the details of the boat, the equipment supplied or fitted, its systems, and information on its operation and maintenance. Please read it carefully and familiarize yourself with the boat before using it.*

*If this is your first boat, or if you are changing to a type of boat you are not familiar with, for your own comfort and safety, please ensure that you obtain handling and operating experience before "assuming command" of the boat. Your dealer or national sailing federation or yacht club will be pleased to advise you of local sea schools and competent instructors.*

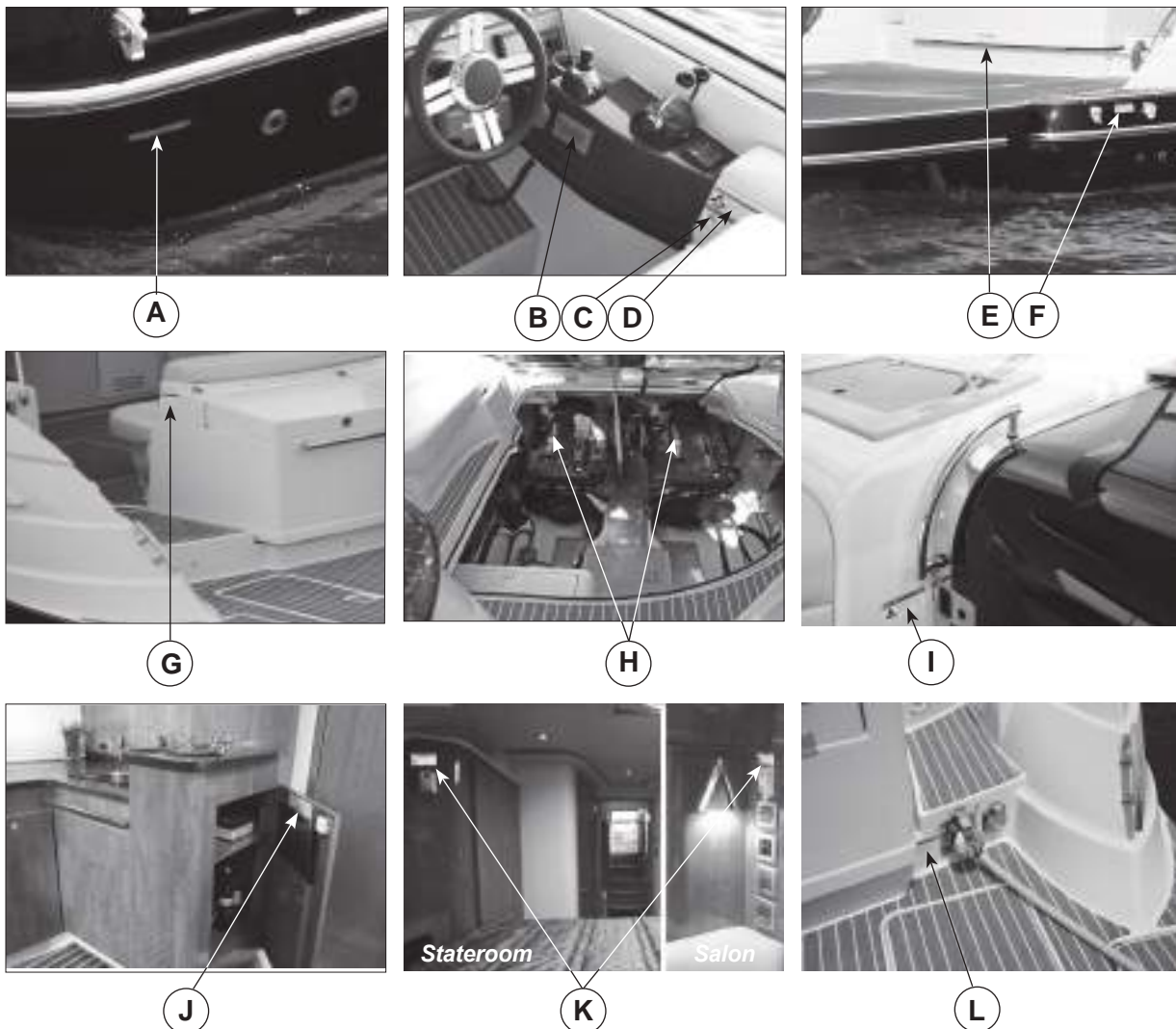
**PLEASE KEEP THIS MANUAL IN A SECURE PLACE, AND HAND IT OVER TO THE NEW OWNER WHEN YOU SELL THE BOAT.**

**LABEL LOCATIONS**

Various warning labels are placed at different locations on each model for your safety. Additional warnings for fuel leakage, blower operation, and other important information will be imprinted or located on the dash. Many of these stickers and labels are not required by the US Coast Guard but are important to ensure the safe operation of your Four Winns® boat. In addition, the Hull Identification Number plate is permanently attached below the deck-hull joint at the stern of the boat on the starboard side.

Below are letters corresponding to the various locations for each item on the drawings. See the following pages of this section for the actual wording of each of the various warning labels found on your boat.

- |                                      |  |
|--------------------------------------|--|
| (A) Hull Identification Number Plate | (G) Transom Door Prevent Falls Overboard Label |
| (B) NMMA Yacht Certification Plate   | (H) Leaking Fuel Warning Label                 |
| (C) Helm Boarding Ladder Warning     | (I) CO - Cabin Door                            |
| (D) CO - Helm Warning Label          | (J) Trash Overboard Discharge Decal            |
| (E) CO - Transom Warning Label       | (K) CO - Cabin Warning Label                   |
| (F) Rotating Prop Boarding Ladder    | (L) Shore Power Inlet Warning Label            |



**Figure 1: Warning Labels and Other Label Locations - Reference Only**  
*(Locations may vary depending upon the model)*

## NMMA CERTIFICATION LABEL, YACHT CERTIFICATION PLATE & WARNING LABELS

**MAXIMUM CAPACITIES**

**11 PERSONS OR 1650 LBS.**

1800 LBS, PERSONS, GEAR

---

**THIS BOAT COMPLIES WITH U.S. COAST GUARD SAFETY STANDARDS IN EFFECT ON THE DATE OF CERTIFICATION**

**MEETS U.S. EPA EVAP STANDARDS USING CERTIFIED COMPONENTS**

**MANUFACTURER: Rec Boat Holdings, LLC dba FOUR WINNS, Cadillac, MI**

DESIGN COMPLIANCE WITH NMMA REQUIREMENTS IS VERIFIED. MANUFACTURER RESPONSIBLE FOR PRODUCTION CONTROL.



**NATIONAL MARINE MANUFACTURERS ASSOCIATION**

**NMMA Capacity Label**

See Actual Capacity Plate Affixed to Boat for Actual Capacities.



**NMMA Yacht Certification Plate**

Replaces NMMA Capacity Label on Certain V series

**Note:** The NMMA Yacht Certification rating (indicated by a yacht certification plate) places the responsibility on the captain to make the determination as to the appropriate load, load placement and number of passengers permitted aboard the vessel.

**CANADIAN COMPLIANCE NOTICE  
AVIS DE CONFORMITÉ CANADIEN**

FOUR WINNS (PFW)  
CADILLAC, MI, USA  
MODEL / MODELE:

THE MANUFACTURER DECLARES THAT THIS VESSEL COMPLIES WITH THE PLEASURE CRAFT CONSTRUCTION REQUIREMENTS OF THE SMALL VESSEL REGULATIONS, AS THEY READ ON THE DAY ON WHICH THE CONSTRUCTION OF THE VESSEL WAS STARTED OR ON THE DAY ON WHICH IT THE VESSEL WAS IMPORTED.

LE FABRICANT ATTESTE QUE CE BÂTIMENT EST CONFORME AUX EXIGENCES DE CONSTRUCTION DES EMBARCATIONS DE PLAISANCE DU RÈGLEMENT SUR LES PETITS BÂTIMENTS EN VIGUEUR À LA DATE DU DÉBUT DE SA CONSTRUCTION OU À LA DATE DE SON IMPORTATION.

**SAMPLE**

**Canadian Compliance Notice**

CE

0609

C



**FOUR WINNS**

SAMPLE - MODEL NAME/YEAR

---

**MAXIMUM**

---

8  +  = 1134 kg

**EU Builders Plate - CE Certification Plate (Export)**



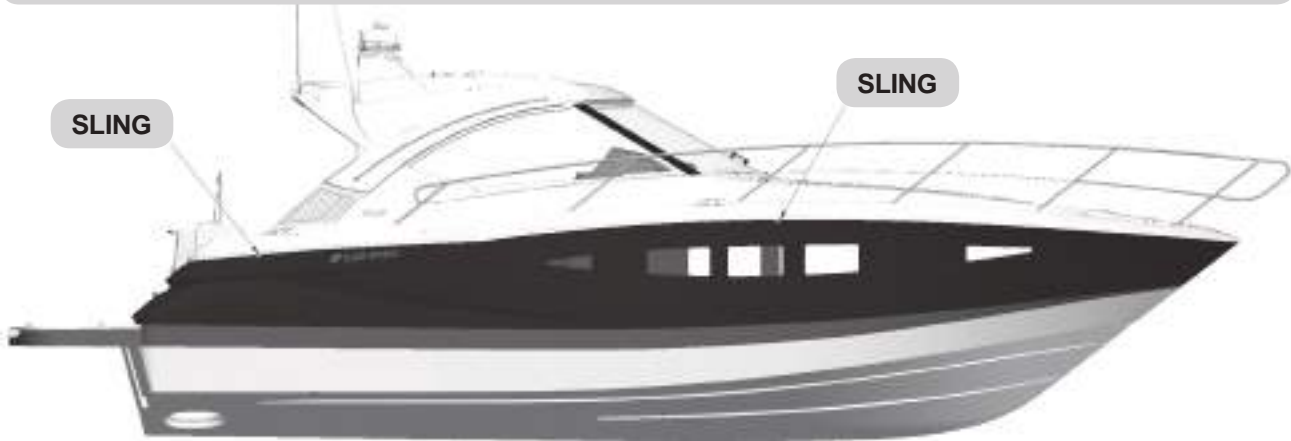
**Winning Edge Sticker**



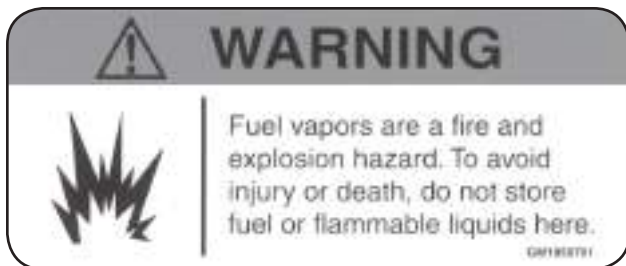
**NMMA Certified Sticker**

 **CAUTION**

Ensure slings are in proper location as indicated by the sling label location. **Failure to do so may result in permanent hull structure damage and will invalidate the hull structure warranty.**



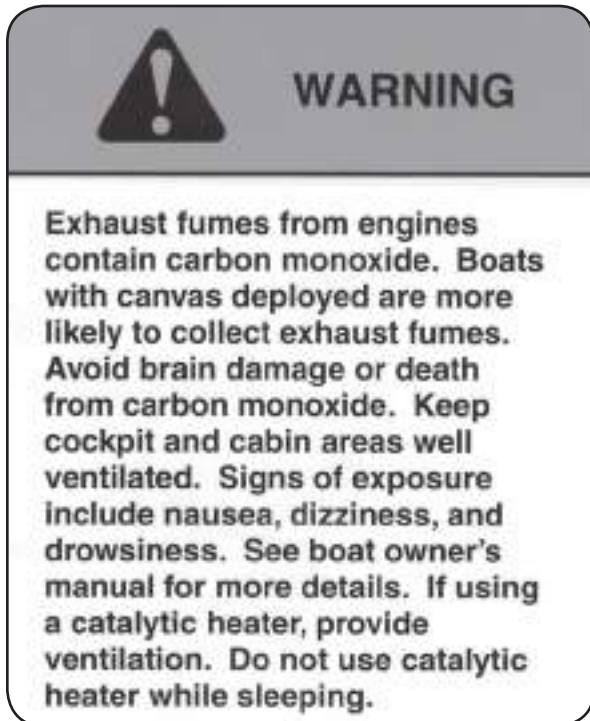
**Figure 2: Sling Locations - Reference Only**  
(Locations will vary depending upon the model)



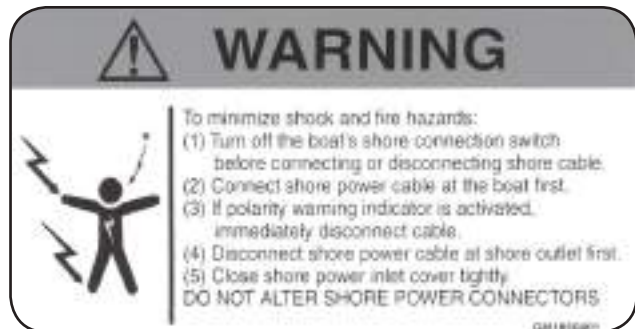
**No Ventilation - Do Not Store Fuel Warning Label**



**Carbon Monoxide - Cabin Doors Warning Label**



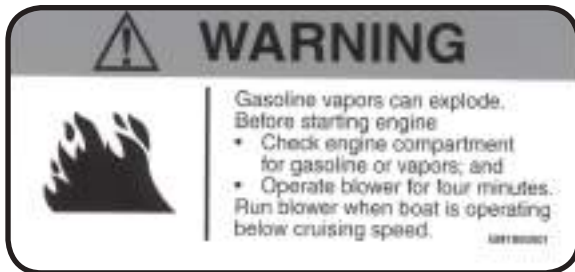
**Carbon Monoxide - Canvas Warning Label**



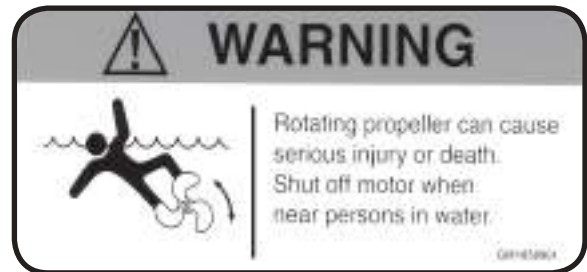
**Shore Power Inlet Warning Label**



**Microwave Caution Label**



*Gasoline Vapor-Blower Warning Label*



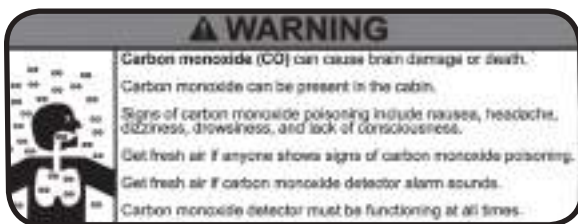
*Rotating Propeller - Helm Warning Label*



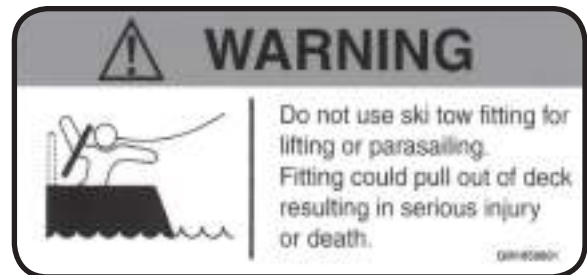
*Rotating Propeller - Ladder Warning Label*



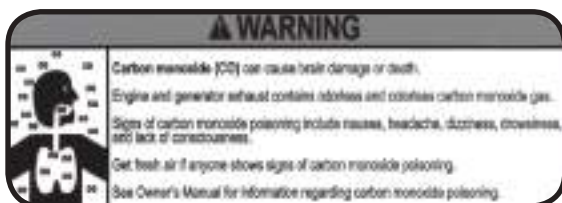
*Leaking Fuel Warning Label*



*CO-Cabin Warning Label*



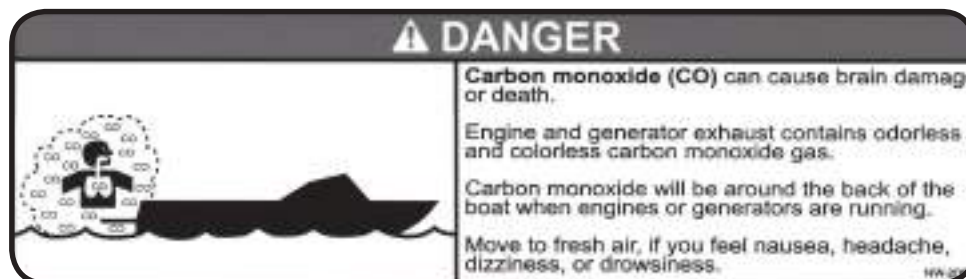
*Ski Tow Warning Label*



*CO-Helm Warning Label*



*Transom/Side Door Warning Label*



*CO Swim Platform and Lounging Area Warning Label*

### A - 1 GENERAL

Before starting the boat, become familiar with all of the various systems and related operations. Be sure all necessary safety equipment is on-board. Know the “Rules of the Road”. Have an experienced operator brief you on the general operation of your new boat. Perform a “pre-cruise systems check”. This manual is a part of your boat’s equipment. Always keep it on board.

### A - 2 COMPONENT SYSTEMS

Before you can really enjoy your boat, a thorough understanding of its systems and their operation is essential. This manual and the associated manufacturers information are included in the owner’s packet. This information is provided to enhance your knowledge of the boat. Read this information carefully.

After becoming familiar with the boat and its systems, reread this manual and other material provided in the owner’s packet. Maintenance and service tips are included to help keep the boat in like-new condition.

### A - 3 SAFETY EQUIPMENT

Besides the equipment installed on the boat by Four Winns certain other equipment is required for passenger safety. A booklet listing the Federal equipment requirements is included in the owner’s packet or is available through your local US Coast Guard Station. Remember that these laws are for your protection and are minimum requirements. Check your local and state regulations, also. More information on safety equipment is provided in Section B.

Items like a sea anchor, working anchor, extra dock lines, flare pistol, a line permanently secured to your ring buoy, etc. could at some time save your passengers lives, or save your boat from damage.

The Coast Guard Auxiliary offers a “Courtesy Examination.” This inspection will confirm the boat is equipped with all of the necessary safety equipment.

### A - 4 PASSENGER SAFETY

You are responsible for the safety of your passengers as well as for their behavior while aboard. Make sure:

1. Each passenger is properly instructed in Personal Flotation Device (PFD) use and keeps one within reach in case of emergency. All non-swimmers and children should wear a PFD at all times when underway.
2. Passengers do not sit on gunwales, open decks, elevated pedestal seats or on seat backs when the boat is underway. This could cause them to be thrown overboard during a sudden maneuver.
3. At least one other person knows how to operate the boat in case of an emergency.

### A - 5 “RULES OF THE ROAD”

As in driving an automobile, there are a few rules that must be known if safe boating operation is to be maintained. The Coast Guard, Coast Guard Auxiliary, Department of Natural Resources or your local boat club sponsor courses in boat handling, including “rules of the road”. Such courses are strongly recommended. Books on this subject are also available from local libraries.

### A - 6 LIGHTNING

When boating, it is important to be aware of the weather around you. When the weather changes for the worse, DO NOT jeopardize your safety by trying to “ride out the storm”. If possible, return to safe harbor and dock your vessel immediately.

If caught in a storm, seek shelter inside the cabin and wait for the storm to pass. With certain models, campers will provide some protection, but should not be relied on if you are able to return to shore. Exercise care when high winds are present!

#### **NOTICE**

*Four Winns boats are **not** equipped with a lightning protection system.*



*DO NOT swim or dangle legs or arms into the water during a lightning storm. Stay out of the water!*

Lightning will seek a ground when it strikes. Avoid contact with metal parts such as bow rails, control handle, or windshield.

## A - 7 DRUGS AND ALCOHOL

Please keep in mind that along with the fun of boating comes responsibility. As the owner or operator of a pleasure boat, you are obligated (morally and legally) to use good judgement while underway in providing for the safety and well-being of your passengers and other boaters around you.

A common and flagrant violation of good judgement and the law by boaters involves the use of alcohol or drugs. Each year, about half of all accidents involving fatalities involve the use of alcohol or drugs.

It is a federal offense to operate a boat while intoxicated. Criminal penalties may include the termination of operating privileges for up to one year. Many states have passed similar laws.

Alcohol or drugs have an inhibiting effect on the judgement and reaction time of the boat operator and his/her passengers. Heed the advice of experts and statisticians...DO NOT drink or use drugs when operating a boat. NEVER allow an obviously intoxicated person to take the helm.

Have fun in your Four Winns® boat, but also have the good sense to be mentally alert and physically capable of operating the boat in a safe manner.

## A - 8 PRE-CRUISE SYSTEMS CHECK

Before leaving the dock, the following items should be checked:

### A. Before Starting The Engine

1. Check the weather forecast. Determine if the cruise planned can be made safely.

2. Be sure all necessary safety equipment is on board and operative. This includes items such as the running lights, horn, spotlight, life saving devices, etc.
3. Conduct an engine and if applicable an engine room general inspection. Check the bilge water level and bilge pump operation. Check the engine oil level, coolant level and drive-unit oil level. Look for other signs of potential problems such as leaks and conduct function checks. Check for the scent of fuel fumes.
4. Activate the Bilge Blower. Check the blower output.



*Fuel vapors can explode resulting in injury or death. Before starting the engine, check engine compartment bilge for fuel or vapors. Operate blower for four minutes, and verify blower operation. ALWAYS run the blower when the vessel is operating below cruising speed.*

5. Ensure an adequate amount of fuel is on board.
6. Be sure you have sufficient water and other provisions on board for the cruise planned.
7. Leave a written message listing details of the planned cruise with a close friend ashore.

### B. After Starting The Engine

1. Visibly check the engine to be sure there are no apparent water or oil leaks.
2. Check the displays . Make sure the oil pressure, water temperature, voltmeter, etc. are reading normally.
3. Have a safe cruise and enjoy yourself.



*Always be sure to raise the anchor and ensure the chain stop is engaged prior to operating your boat. Failure to raise and secure anchor before getting underway could result in damage to boat and even severe injury or death from a rebounding anchor.*

## A - 9 ENGINE OPERATIONAL PROCEDURES

### NOTICE

**Consult engine operator's manual for specific procedure for your particular model.** The following information is general in nature. Additional general information is located in Section T.

### A. Before Starting

1. Ensure an adequate amount of fuel is on board. Open the fuel valves.
2. Check the engine compartment for water, fuel, and/or oil leaks of any kind. Keep the bilge in a clean condition to prevent blower and bilge pump damage and fire hazards.
3. Check the fluid levels of the engine oil and drive-unit daily before first start. Fill oil or drive-unit as required by the indications on the dip sticks. Refer to your engine manual included in the owner's packet. Follow engine manufacturer's recommendations.

Diesel engines use a Series IIID oil, SAE15W/40. Refer to your engine manual included in the owner's packet. Follow engine manufacturer's recommendations.

### NOTICE

**IMPORTANT:** Lubrication requirements for catalyzed engines differ from the requirements for non-catalyzed engines. Some marine-grade lubricants contain high levels of phosphorus, which can damage the catalyst system. Although these high phosphorus lubricants may allow acceptable engine performance, exposure over time will damage the catalyst. Catalysts damaged by lubricants containing high levels of phosphorus may not be covered by the engine manufacturer's warranty.

3. Power steering and power trim use automatic transmission fluid. Check the fluid levels in the vertical drive units or transmission as often as practical.
4. Start and operate the bilge blower system for at least four (4) minutes before start-up.
5. Check all electrical systems and navigation lights.

6. Lower the vertical outdrive units (if applicable) making sure the water intakes are under the water.

### B. Cold / Warm Engine Start - EFI & Diesel

1. If your boat is equipped with a battery selector switch, turn the battery switch to I (ON), or COMBINED BATTERY (emergency start) position (positions may vary depending on which model you have).
2. Attach the ignition interrupt lanyards securely to your body (if applicable). In the event that you move away from the helm area and beyond the length of the lanyard, the engine will be turned off.
3. Move the shifter to NEUTRAL the detent position.
- 4a. Turn the key switch to start and hold until engine starts, for no longer than 10 seconds. If engine does not start, let go momentarily, then try again.
- 4b. For certain diesel engines, you must first turn the ignition key to the ON position and wait 30 seconds, allowing preheaters to activate. After 30 seconds, turn key switch to START position and hold until engine starts. DO NOT hold in START position for more than ten seconds. Be sure to follow the engine operator's manual for specific starting procedures for your particular diesel engine
5. As soon as engine starts, release key to ON or RUN.

### NOTICE

Priming is not necessary for EFI engines. Refer to the engine owner's manual for additional information.

### NOTICE

NEVER turn key to START position when engine is running.

### NOTICE

When starting engine, do not allow engine to "over-rev". Engine damage could result. "Over-revving" engine after off-season storage could also damage the water pump impeller.

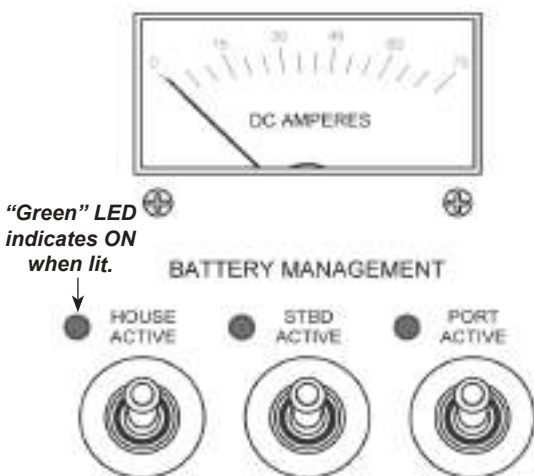


### NOTICE

When starting engine for the first time after off-season storage, always idle engine for ten minutes to allow the water pump to prime.

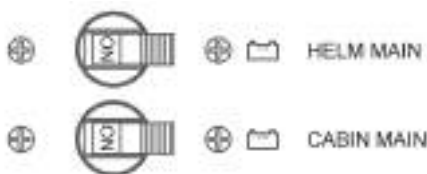
### C. Starting Procedures for Diesel Engines with Volvo Penta Electronic Vessel Control (EVC)

1. Activate the 3 batteries (Port, Stbd & House) by pressing the respective main battery switches located on the 12VDC cabin panel. See Figure A1.



**Figure A1: Battery Activation Switches - "ON"**  
(Certain Models Only - Panels & Switches Vary)

2. Turn the HELM MAIN circuit breaker switch ON located on the 12VDC cabin panel. See Figure A2.



**Figure A2: Helm & Cabin Main Circuit Breakers - "OFF"**  
(Certain Models Only - Panels & Switches Vary)

3. Start and operate the bilge blower system for at least four (4) minutes before start-up.
4. Open the seawater seacocks on the drive units.
5. Place the drive-unit in neutral by moving the control levers to the neutral positions.
6. Move the dual shift/throttle lever of the control head to the neutral idle detent positions (N). Note: The engine can only be started if the control is in the neutral detent position. When in the neutral

idle detent position, press the neutral button "N" in and hold it down while moving the control lever forward to the forward shift position. Release the neutral button. The green indicator begins to flash indicating the shift function has been disengaged. The lever now only controls engine speed which permits engine warm-up. See the manufacturer's literature for further details. Moving the lever back to the neutral detent position will automatically re-engage the shift function which is indicated by the constant green light.



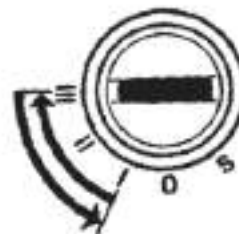
Take care not to engage the drive-unit unintentionally.

7. Turn the ignition key to the ON position "I" and wait 20 seconds, allowing pre-heaters to activate. See Figure A3.



**Figure A3: Ignition Switch ON Position**

8. Check for audible warnings, information messages or alarms on EVC system displays.
9. After 20 seconds, turn key switch to START position and hold until engine starts. DO NOT hold in START position for more than ten seconds. See Figure A4. **Note:** If one of the designated engine batteries fails to start its respective engine, engage the "EMERGENCY START" switch at the helm and attempt to start the engine.



**Figure A4: Ignition Switch START Position**

10. As soon as engine starts, release key to the ON or RUN position.

**NOTICE**

Allow the engine to idle for the first ten seconds. Monitor all instruments and displays to ensure normal readings are shown. Check that no alarms are displayed and that no warning lights are flashing. Then warm the engine at low speed and low load until engine reaches normal temperature before full power is used.

**NOTICE**

Priming is not necessary for EFI engines. Refer to the engine owner's manual for additional information.

**NOTICE**

NEVER turn key to START position when engine is running.

**NOTICE**

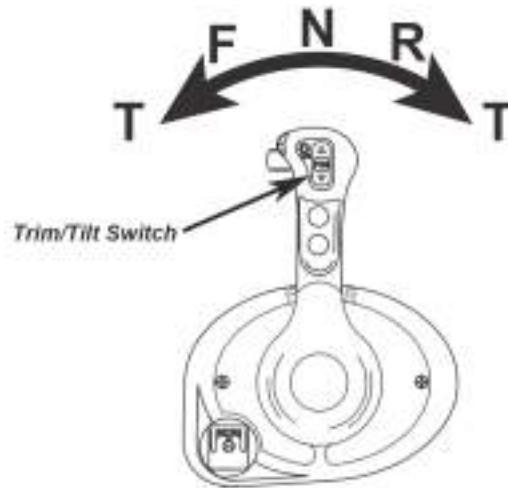
Failure to move the throttle handle to the idle position immediately when engine starts will allow engine to "over-rev" and engine damage could result. "Over-revving" engine after off-season storage could also damage the water pump impeller. **When starting engine for the first time after off-season storage, always idle engine for ten minutes to allow the water pump to prime.**

**D. Shifting and Control Speed**

**NOTICE**

If your boat is equipped with a non-OEM remote control system, ask your dealer how to properly operate it.

1. Move shift/throttle lever(s) to the neutral idle position (N). Placing the shift/throttle levers in the neutral detent position will engage neutral start switch and allow engine to start. Refer to Figures A5 & A6.



**Figure A5: Shift/Throttle Control - Single Engine**  
(Depending on Engine Configuration Models Will Vary)



**Figure A6: Control Lever Positions - Dual Binnacle**  
(Representative View - Models may vary)

2. To go FORWARD - move the shift/throttle lever(s) forward (F). Once forward gear engagement is complete, push shift/throttle lever(s) forward until desired speed is achieved (T).
3. To go in REVERSE - move the shift/throttle lever(s) rearward (R). Once rearward gear engagement is complete, push shift/throttle lever(s) rearward until desired speed is achieved (T).



**DO NOT** shift from forward to reverse when the boat is planing.

- To go from FORWARD to REVERSE, or REVERSE to FORWARD; always pause at NEUTRAL and allow engine speed to fall below 1500 RPM.

#### NOTICE

*On certain models, if you attempt to shift gear at an excessive engine speed, a safety function cuts in automatically, and delays shifting until engine speed has fallen below 1500 RPM.*

- After shifting is completed, slowly push throttle lever(s) forward/rearward until desired speed is achieved.



*On a boat with twin engines it is important that both engines be running during reverse procedures, to avoid the risk of water entry (via the exhaust pipe) into a stationary engine.*



*Any time the boat is operated, be aware of changes in shift system operation. A sudden increase in shift effort of the shifter levers, or other abnormal operation, indicates a possible problem in the shift system. If this occurs, the following precautions must be taken:*

- With engine running and boat securely tied to the dock, shift drive into forward and reverse to ensure there is gear engagement.
- When docking the boat, all docking maneuvers must be performed at slow speed. Pay special attention to other boaters. Passengers should be informed of potential problems and precautions taken.

If you suspect there is a problem, see your engine manufacturer's authorized service center as soon as possible for proper diagnosis and required service or adjustment. Continued operation could result in damage to the shift mechanism and loss of control.

#### E. Stopping Engine - EFI & Diesel

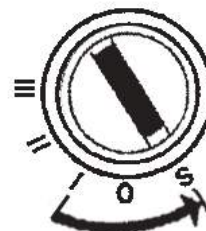
- Move shifter/throttle lever(s) to the NEUTRAL position.
- Turn ignition key to the OFF position.

#### NOTICE

*DO NOT stop engine at speeds above idle or "speed up" engine while turning off ignition. Engine damage could result.*

#### F. Stopping Engine for Diesel Engines with Volvo Penta Electronic Vessel Control (EVC)

- Move shifter lever(s) to the NEUTRAL position. Allow engines to idle for a few minutes (in neutral) before turning them OFF. This will avoid boiling and even out the temperature. This is especially important if the engines have been operated at high engine speeds and loads.
- Turn ignition key to the STOP position "S" Keep the key turned until the engine stops. The key will automatically return to the OFF position "0" when released and then can be removed. See Figure A7.



**Figure A7: Ignition Switch STOP Position**



*Never switch OFF the main battery switches while engines are running. This could damage the alternator.*



*Never switch OFF the main battery switches before the starter key is turned OFF (is in the "0" position or removed). This could damage the electrical system.*



*DO NOT stop engine at speeds above idle or “speed up” engine while turning off ignition. Engine damage could result.*

With the Inboard Performance System (IPS) engines, when they are stopped the drive-units will automatically be positioned in the straight forward position.

### G. After Stopping Engine(s)



*Ensure the starter key is turned OFF (is in the “0” position or removed) before main battery switches are turned OFF. Otherwise the electrical system could be damaged.*

1. Inspect the engines and engine compartment for any leaks.
2. Switch OFF the main battery switches located either at the battery switch panel, Power Management Center or at the 12VDC cabin panel if the boat is not to be used for some time.

## A - 10 GROUNDING AND TOWING



*If the boat should become disabled, or if assisting another craft that is disabled, great care must be taken. The stress applied to a boat during towing may become excessive. Excessive stress can damage the structure of the boat and create a safety hazard for those aboard.*

Four Winns® boats are not designed nor intended to be used as a towing vessel. The mooring cleats on Four Winns® boats are not designed or intended to be used for towing purposes. These cleats are specifically designed as mooring cleats for securing the boat to a dock, pier, etc. DO NOT use these fittings for towing or attempting to free a grounded vessel.

Freeing a grounded vessel or towing a boat that is disabled requires specialized equipment and knowledge. Line failure and structural damage caused by improper towing have resulted in fatal injuries. Because of this, Four Winns strongly suggests that these activities be left to those who have the equip-

ment and knowledge such as the US Coast Guard or Sea Tow®, to safely accomplish the towing task.



*Running aground can cause serious damage to a boat and associated underwater gear. If the boat should become grounded, distribute personal flotation devices and inspect the boat for possible damage. Thoroughly inspect the bilge area for signs of leakage. An experienced service facility should check the hull and underwater gear at the first opportunity. DO NOT continue to use the boat if the condition of the hull or underwater equipment is questionable.*

If towing or being towed is absolutely necessary, use the strongest lines available, and attach them to the bow eyes or stern eyes only. Have all passengers slip on life jackets and take a seat in the cabin or other protected area.



*Lines can snap or other hardware can be loosened or broken while towing. Under certain conditions, this can cause severe injury or fatality.*

## A - 11 BOATING EDUCATION

### A. Boating Courses

Boating education classes are offered throughout the country. The United States Coast Guard Auxiliary offers free courses on different topics usually during the off-season. The most popular course is the “Boating Skills & Seamanship Course,” and information can be obtained by calling 1 800-336-BOAT (2628) or by visiting their website at: [www.boatus.com/courseline](http://www.boatus.com/courseline).

The United States Power Squadron also offers free courses ranging from basic seamanship to celestial navigation. For information, contact your local Power Squadron, or write: USPS, P.O. Box 30423, Raleigh, NC 27622 or visit their website at: [www.usps.org](http://www.usps.org). The World Wide Web contains many websites devoted to boating and boating safety. One such site is [www.discoverboating.com](http://www.discoverboating.com) which contains many informative articles and website links for both the new boater as well as the experienced boater alike.

The Canadian Power and Sail Squadron offers seamanship courses. Information may be obtained by visiting their website at [www.cps-ecp.ca/](http://www.cps-ecp.ca/).

## B. Boating Manuals or Literature

A good source of information is the US Coast Guard's home study book called "The Skipper's Course". This book may be purchased through Superintendent of Documents, US Government Printing Office, Washington, DC 20402, Stock # 050-012-00159-6.

Another good source of boating information is Chapman's "Piloting, Seamanship and Small Boat Handling". Also, check the local library or bookstore for additional information on boating.

## C. Charts and Maps

US nautical charts are sold throughout the country at Governmental Printing Office stores and other agents. Chart catalogs are available by visiting the National Oceanic and Atmospheric Administration website at <http://nauticalcharts.noaa.gov/mcd/ccatalogs.htm#state>.

In addition, many federal agencies publish recreational maps, including the US Army Corp of Engineers, the Forest Service, the National Park Service, and the Tennessee Valley Authority.

Addresses of all state boating law administration offices are found in the "Boating Basics, A Guide to Responsible Boating", included in your owner's packet. Additional copies may be purchased by contacting Outdoor Empire Publishing at [www.outdoor-empire.com](http://www.outdoor-empire.com).

## D. Laws and Regulations

The US Coast Guard is the authority of the waterways; they are there to help the boating public. State boating regulations are enforced by local authorities. You are subject to marine traffic laws and "Rules of the Road" for both federal and state waterways; you must stop if signaled to do so by enforcement officers, and permit to be boarded if asked.

There are many pamphlets, prepared by the US Coast Guard, available to you. These pamphlets explain "Rules of the Road," signal lights, buoys, safety, international and inland regulations and other information which goes beyond the scope of this manual.

For more information contact your local US Coast Guard Unit or call the Coast Guard info line at 1 800 368-5647, or visit the US Power Squadron website at [www.usps.org](http://www.usps.org).

## A - 12 BOAT OWNER REGISTRATION

Federal and state laws require that every boat equipped with propulsion machinery of any type must be registered in the primary state of usage. Registration numbers and validation stickers must be displayed on the boat according to regulations. In most states, this means registration with the designated state agency. In a few jurisdictions, the Coast Guard retains registration authority. Your dealer will either supply registration forms or tell you where they may be obtained. The registration agency will issue you a certificate that must be carried on board when the boat is in use. Some states require additional registration when an out of state boat is used within their boundaries.

Your boat has a hull identification number on the starboard side of the hull. Figure A8 shows a typical identification number. Use this hull identification number for registration and to identify your boat for warranty service.

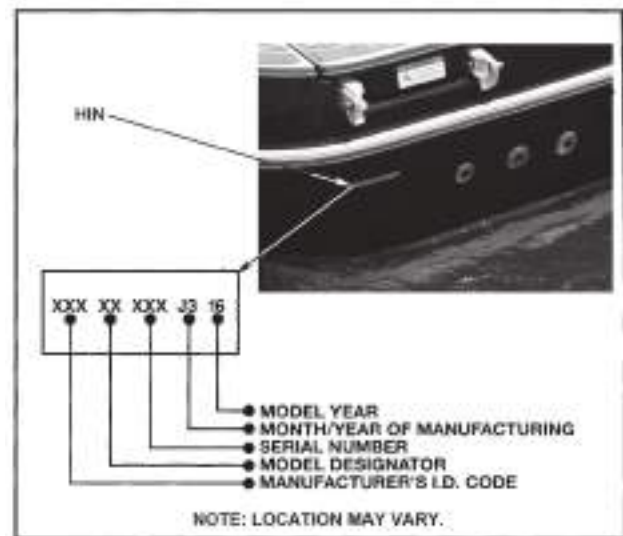


Figure A8: HIN

In most states, the boat owner is legally responsible for damages or injuries he or she causes, even if someone else is operating the boat at the time of the accident. Common sense dictates that you carry adequate personal liability and property damage insurance on your boat, just as you would on an automo-

bile. You should also protect your investment by insuring your boat against physical damage or theft.

### **A - 13 ACCIDENT REPORTING**

The operator of the boat is responsible for filing a report with the appropriate authorities. In general, reports are necessary for accidents involving loss of life, injury, or damage over \$500. In the case of accidents with reportable injuries or death, a formal report is required within 48 hours. If only property damage is involved, a report must be made within ten days. The 1971 Boating Safety Act may impose a \$1,000 civil fine for people who fail to submit a boating accident report. Ask your insurance agent for more information. The Department of Homeland Security, US Coast Guard's Recreational Boating Accident Report has been included at the end of this manual to assist you should you need to refer to it. You may also access it online at [https://www.uscg.mil/forms/cg/CG\\_3865.pdf](https://www.uscg.mil/forms/cg/CG_3865.pdf).

If you see a distress signal, you must assume it is a real emergency and render assistance immediately. The master or person in charge of a boat is obligated by law to provide assistance to any individual in danger at sea. However, you should not put your boat or crew in a dangerous situation which exceeds your capabilities or those of your boat. The 1971 Boating Safety Act grants protection to a Good Samaritan boater offering good faith assistance, and absolves a boater from any civil liability arising from assistance given.

### **A - 14 DISCHARGE OF OIL**

The Federal Water Pollution Control Act prohibits the discharge of oil waste into or upon the navigable waters of the United States or the waters of the contiguous zone if such discharge causes a film or sheen upon or a discoloration of the surface of the water or causes a sludge or emulsion beneath the surface of the water. Violators are subject to a penalty of \$5,000.

### **A - 15 DISPOSAL OF PLASTICS & OTHER GARBAGE**

Plastic refuse dumped in the water can kill fish and marine wildlife and can foul boat propellers and cooling water intakes. Other forms of waterborne garbage can litter our beaches and make people sick. US Coast Guard and most state regulations prohibit the dumping of plastic refuse or other garbage mixed with plastic into the water anywhere, and restrict the dumping of other forms of garbage within specified distances from shore.

### **A - 16 MARPOL TREATY**

Boats 26 feet or longer must display a sign stating the disposal regulations of the Federal Water Pollution Control Act. The US Coast Guard has issued these regulations to implement Annex V of the International Convention for the Prevention of Pollution from Ships, 1973, commonly known as Annex V of the MARPOL (Marine Pollution) Treaty 73/78. They apply to all US boats wherever they operate (except waters under the exclusive jurisdiction of a State) and foreign boats operating in US waters out to and including the Exclusive Economic Zone (200 miles). It is important to know these regulations and adhere to them.

The regulations require US recreational boaters, if your boat is 26 feet or more in length, to affix one or more USCG Trash Dumping Restrictions placards to your boat. The placard warns against the discharge of plastic and other forms of garbage within the navigable waters of the United States and specify discharge restrictions beyond the territorial sea. (The territorial sea generally ends three nautical miles from the seashore.) In addition, the placard must contain the warning that a person who violates these requirements is liable to civil (\$25,000) and criminal (imprisonment) penalties. The placard also must note that State and local regulations may further restrict the disposal of garbage.

Operators shall display one or more placards in a prominent location and in sufficient numbers so they can be observed and read by crew and passengers. These locations might include embarkation points, food service areas, galleys, garbage handling spaces and common deck spaces frequented by crew and passengers. We recommend that these placards may be purchased from local marinas, boat dealerships and marine equipment suppliers. A special placard is available for boats operating on the Great Lakes.

**NOTICE**

*IMPORTANT: It is illegal to discharge waste from your marine sanitary device (toilet) into the water in most areas. It is your responsibility to be aware of and adhere to all local laws concerning waste discharge. Consult with the Coast Guard, local marina or your dealer for additional information.*

**NOTICE**

*NOTE: Some states and localities have legal limits on speed, noise and trailer specifications. It is your responsibility to be aware of these laws and limits and to insure that your boat (and trailer) comply. Consult with your local Marine Patrol or local Coast Guard office.*



## B - 1 GENERAL

As the owner/operator of the boat, you are responsible for assuring that all required safety equipment is aboard. You should also consider supplying additional equipment as needed for your safety and that of your passengers. Check state and local regulations and visit the US Coast Guard's Office of Boating Safety website at [www.uscgboating.org](http://www.uscgboating.org) for information about required safety equipment. Also visit the United Power Squadron website at [www.usps.org](http://www.usps.org).

### A. Required Safety Equipment

Most of the safety equipment required by federal regulations is provided as standard equipment. Personal Flotation Devices (life jackets) must fit the persons wearing them. Minimum requirements include the following:

- Personal Flotation Devices
- Visual Distress Signal
- Bell or Whistle
- Fire Extinguisher
- Navigation Lights

#### NOTICE

*As the owner/operator of the boat, you are responsible for assuring that all required safety equipment is aboard and meets the boating regulations as prescribed by both federal and local authorities in your area.*

### B. Personal Flotation Devices (PFDs)

Federal regulations require that you have at least one Coast Guard approved personal flotation device (PFD) for each person in a recreational boat. You should not use your boat unless all PFDs are in serviceable condition, readily accessible, legibly marked with the Coast Guard approval number, of an appropriate size (within the weight range and chest size marked on the PFD) for each person aboard.

A PFD provides buoyancy to help keep your head above the water and to help you remain in a satisfactory position while in the water. Body weight and age should be considered when selecting a PFD. The buoyancy provided by the PFD should support your weight in water.

The size of the PFD must be appropriate for the wearer. Body weight or chest size are common methods

used to size PFDs. It is your responsibility to ensure that you have the proper number and types of PFDs on board and that your passengers know where and how to use them.

### C. PFD Types

Five types of PFDs have been approved by the US Coast Guard. The PFDs are described as follows:

**PFD Type 1, Wearable** (Figure B1) has the greatest required buoyancy. Its design allows for turning most unconscious persons in the water from face down position to a vertical or slightly backward, face-up position. It can greatly increase the chances of survival. Type 1 is most effective for all waters, especially offshore when rescue may be delayed. It is also the most effective in rough waters.



**Figure B1: Type I, Wearable**

**PFD Type II, Wearable** (Figure B2) turns its wearer in the same way as Type I, but not as effectively. The Type II does not turn as many persons under the same conditions as a Type I. You may prefer to use this PFD where there is a probability of quick rescue such as in areas where other people are commonly involved in water activities.



**Figure B2: Type II, Wearable**

**PFD Type III, Wearable** (Figure B3) allows the wearer to place themselves in a vertical or slightly backward position. It does not turn the wearer. It maintains the wearer in a vertical or slightly backward position and has no tendency to turn the wearer face down. It has the same buoyancy as a Type II PFD and may be appropriate in areas where other people are commonly involved in water activities.





**Figure B3: Type III, Wearable**

**PFD Type IV, Throwable** (Figure B4) is required in addition to the PFDs previously discussed. The most common Type IV PFD is a buoyant cushion or ring buoy. It is designed to be thrown to a person in the water, grasped and held by the user until he or she is rescued. A Type IV PFD should always be in serviceable condition and immediately available for use. Grasping this PFD may be difficult if the rescue is delayed or if the user is overcome by hypothermia (loss of body heat).



**Figure B4: Type IV, Throwable**

**PFD Type V, Wearable** (Figure B5) when inflated, it provides buoyancy equivalent to Type I, II, or III PFDs. When it is deflated, however, it may not support some people.



**Figure B5: Type V, Wearable**

#### D. PFD Pointers

The purpose of a PFD is to help save your life. If you want it to support you when you are in the water, it needs to fit, float, and be in good condition.

1. Try the PFD on and adjust it until it fits comfortably in and out of the water. Mark your PFD if you are the only wearer.
2. To make sure the PFD works, wear it in the water. This will show you how it works and give you confidence when you use it.

3. Teach children how to put a PFD on and allow them to try it in the water. That way, they know what the PFD is for and how it works. They will feel more comfortable with it if they suddenly find themselves in the water.
4. If the PFD is wet, allow it to dry thoroughly before storing it. Do not dry it in front of a radiator or heater. Store it in a well ventilated area.
5. Keep PFDs away from sharp objects which can tear the fabric or puncture the flotation pads.
6. For their own safety and the safety of others, all non swimmers, poor swimmers, and small children should wear PFDs at all times, whether the boat is stationary or moving.
7. Check the PFD frequently to make sure that it is not torn, that flotation pads have no leaks, and that all seams and joints are securely sewn.
8. If a PFD contains kapok, the kapok fibers may become waterlogged and lose their buoyancy after the vinyl inserts are punctured. If the kapok becomes hard or if it is soaked with water, replace it. It may not work when you need it.

#### E. Fire Extinguisher

As the owner/operator of the boat, you are responsible for supplying a fire extinguisher approved by the US Coast Guard.

Hand-held portable extinguisher(s) should be mounted in a readily accessible location(s) away from the engine compartment. All persons aboard should know the location(s) and proper operation of the fire extinguisher(s).



#### **FIRE**

*In case of fire do not open the engine compartment. Shut down engine(s), generator(s), and blower(s). Discharge entire contents of fixed fire suppression system, if equipped. If using a portable CO2 fire extinguisher, continuously discharge entire contents. On export models, discharge contents through fire port.*

**NOTICE**

*Using a portable fire extinguisher with an access/fire port in the engine compartment is preferred to opening the engine compartment to fight the fire. However, using a portable extinguisher in this way provides less protection against fire than a fixed suppression system.*

**NOTICE**

*Do not test fire extinguishers by squirting small amounts of the extinguishing compound. The fire extinguisher might not work when you really need it.*

The V series models that measure 26 to less than 40 feet are considered Class 2 powerboats. All Class 2 powerboats are required to carry two (2) B-I type approved hand portable fire extinguishers or one (1) B-II type approved hand portable fire extinguisher. When a fixed fire extinguishing system is installed in machinery space(s), at least one (1) B-I type approved hand portable fire extinguisher is required.

All Class 3 powerboats (40 to less than 65 feet) are required to carry a minimum of three (3) B-I type, US Coast Guard approved, hand portable fire extinguishers when there is **no** fixed fire extinguishing system in the machinery space. If the boat is equipped with a fixed fire extinguishing system in the machinery space the minimum requirement of two (2) B-I type approved hand portable fire extinguishers is required. **Additional note:** One (1) B-II type approved hand portable fire extinguisher may be substituted for two (2) B-I type approved hand portable fire extinguishers.

**F. Fire Extinguisher System**

An automatic fire extinguisher system is available on certain boat models. The type of extinguishing agent used may vary. Other models may have a fire extinguishing system in conjunction with an automatic shut-down system available. If applicable, the equipment utilized has been so chosen, and located, to provide sufficient volume and coverage of the entire engine compartment. While the system ensures excellent overall bilge fire protection, it does not eliminate the USCG requirement for hand-held fire extinguishers. Refer to the manufacturer’s literature included in the owner’s packet if this feature has been installed.

On models equipped with an automatic HFC-227ea agent fire extinguisher system If fire breaks out aboard a diesel powered vessel, the engine(s) must be shut

down immediately for the fire extinguisher system to effectively extinguish the fire. Continued engine operation may remove the agent, lowering the concentration required to effectively extinguish the fire.

**G. Visual Distress Signal Devices**

Visual distress signal devices approved by the US Coast Guard are required on all recreational boats operating on coastal waters and to boats owned in the United States when they are operating on the high seas. Coastal waters include territorial seas and those waters directly connected to the Great Lakes and the territorial seas up to a point where the waters are less than two miles (3.2km) wide. Visual distress signal equipment may be of the pyrotechnic or non-pyrotechnic type. Regulations prohibit display of visual distress signals on the water under any circumstances except when assistance is required to prevent immediate or potential danger to persons on board a vessel.

The equipment must be approved by the US Coast Guard, be in serviceable condition, and be stowed in a readily accessible location. Equipment having a date for serviceable life must be within the specified usage date shown. Careful selection and proper stowage of visual distress equipment is very important if young children are aboard.

DAY USE ONLY	NIGHT USE ONLY	DAY AND NIGHT USE
Three orange smoke signals (one hand held and two floating) or one orange flag with black square and disk.	One S-O-S electric distress light.	Three flares of the hand held, meteor or parachute type.

**Distress Signal Table**

The minimum visual distress signals required in coastal waters for a Class 1 or Class 2 powerboat is the following:

One orange flag with black square and disc (daytime); and an S-O-S electric light (nighttime); or three orange smoke signals, hand-held or floating (daytime); or three red flares of hand-held, meteor, or parachute type (daytime/nighttime).

### NOTICE

*No single signaling device is appropriate for all purposes. Consider keeping various types of equipment on board.*

## H. Sound Signaling Devices

Class 1 and Class 2 powerboats are required to carry a hand, mouth or power operated horn or whistle. It must produce a blast of two-second duration and audible at a distance of at least one-half (1/2) mile.

The following are standard whistle signals:

- One Prolonged Blast = Warning Signal
- One Short Blast = Pass on my Port Side
- Two Short Blasts = Pass on my Starboard Side
- Three Short Blasts = Engines in Reverse
- Five or More Blasts = Danger Signal

## I Navigation Lights

Navigation lights are intended to keep other vessels informed of your presence and course. If you are out on the water between sunset and sunrise, you are required to display appropriate navigation lights.

## J. Additional Recommended Equipment

Four Winns® recommends that you acquire additional equipment for safe, enjoyable cruising. This list, while not all-inclusive, suggests items you should consider acquiring.

### Basic Gear

Flashlight	Spare batteries	Tow line
Oar, paddle	Mooring lines	Compass
Dock fenders	Distress signals	First aid kit
Boat hook	VHF radio	EPIRB*
Sunscreen	Extra warm clothing	Charts

Second anchor & line

Dewatering device (pump or bailer)

Emergency supply of drinking water and food

\*Emergency Position Indicating Radio Beacon

### Tools

Spark plug wrench	Hammer	Screwdriver
Jackknife	Pliers	
Electrical tape	Duct tape	
Adjustable wrench	Lubricating oil	Prop wrench

### Spare Parts

Extra bulbs	Spare prop	Extra fuses
Extra drain plug	Spark plugs	Spare wire
Extra prop nut/washer		

### Gear For Extended Cruises

Foul weather gear      Parallel rulers      Dividers  
Global Positioning System navigation equipment

## B - 2 CARBON MONOXIDE



### **CARBON MONOXIDE!**

*Carbon monoxide (CO) can be harmful or fatal if inhaled. Brain damage or death can result from prolonged exposure to carbon monoxide. Keep exhaust outlets clear of blockage. Provide adequate ventilation. Open hatches, doors, windows and vents to insure adequate ventilation. Close engine compartment doors and hatches when engine or generator is running. Avoid operating the boat for extended periods of time at idle speed, and be sensitive to weather conditions that may prevent CO from dissipating into the air. Do not stand or swim near engine or generator exhausts when engines are running.*

Carbon monoxide accumulation is affected by many variables (e.g., boat geometry, hatch, window and door opening, ventilation openings, proximity to other structures, swim platforms, canvas enclosures, location of exhaust outlets, vessel attitude, wind direction, vessel speed, boat systems maintenance, etc.) The technical information included in this section is to inform the boat owner of possible cause and effects of carbon monoxide exposure. This information has been reprinted with permission from the American Boat and Yacht Council's (ABYC) technical information report: "Educational Information About Carbon Monoxide". This information pertains to all gasoline-powered boats manufactured by Four Winns.

### NOTICE

*The boat owner should be aware that other factors may contribute to carbon monoxide accumulation. The most common ones are listed in this section. If a person is exhibiting carbon monoxide-type symptoms (Refer to B-2E Symptoms), be sure to take the necessary precautions as prescribed later in this section.*

### NOTICE

*Boats fueled by diesel have limited carbon monoxide present in the exhaust in comparison to gasoline engine exhaust. However, the boat owner should still be aware of the causes and effects of carbon monoxide which may occur in different boating situations.*

#### A. Properties and Characteristics of Carbon Monoxide

1. Carbon monoxide is a colorless, odorless and tasteless gas. It is commonly referred to as CO.
2. Its weight is about the same as air so it cannot be expected to rise or fall like some other gases, but will distribute itself throughout the space.

### NOTICE

*DO NOT rely on the use of smell or sight of other gases to detect CO, because it diffuses in the air much more rapidly than easily detectable vapors (i.e., visible and aromatic vapors).*

#### B. What Makes Carbon Monoxide

Any time a material containing carbon burns such as gasoline, natural gas, oil, propane, coal, or wood, CO is produced.

Common sources of carbon monoxide are:

1. Internal combustion engines such as:
  - a. Propulsion engines
  - b. Generators
2. Open flame devices such as:
  - a. Cooking ranges
  - b. Central heating plants
  - c. Space heaters
  - d. Water heaters
  - e. Fireplaces
  - f. Charcoal grills

#### C. How a Person is Affected by Carbon Monoxide

Carbon monoxide is absorbed by the lungs and reacts with blood hemoglobin to form carboxyhemoglobin, which reduces the oxygen carrying capacity of the blood. The result is a lack of oxygen for the tissues

with the subsequent tissue death and, **if exposure is prolonged, death of the individual.**

#### D. Effects of Carbon Monoxide

Carbon monoxide in high concentrations can be fatal in a matter of minutes. Lower concentrations must not be ignored because the effects of exposure to CO are cumulative and can be just as lethal.

Certain health related problems and age will increase the effects of CO. People who smoke or are exposed to high concentrations of cigarette smoke, consume alcohol or have lung disorders or heart problems, are particularly susceptible to an increase in the effects from CO; however, all occupants' health should be considered. Physical exertion accelerates the rate at which the blood absorbs CO.

#### E. Symptoms

One or more of the following symptoms can signal the adverse effect of CO accumulation:

1. Watering and itchy eyes
2. Flushed appearance
3. Throbbing temples
4. Inattentiveness
5. Inability to think coherently
6. Loss of physical coordination
7. Ringing in the ears
8. Tightness across the chest
9. Headache
10. Drowsiness
11. Incoherence
12. Slurred speech
13. Nausea
14. Dizziness
15. Fatigue
16. Vomiting
17. Collapse
18. Convulsions

### NOTICE

*The order of the above list is generally the sequence of appearance of symptoms. However, the order of appearance may change for different people.*

### NOTICE

*The symptoms of carbon monoxide poisoning may easily be mistaken for seasickness or alcohol intake.*

## F. Treatment (Evaluate, Ventilate, Evacuate, Investigate, Take Corrective Action)

1. Evaluate the situation and ventilate the area if possible.
2. Evacuate the area and move affected person(s) to a fresh air environment.
3. Observe the victim(s).
4. Administer oxygen if available.
5. Contact medical help. If the victim is not breathing, perform rescue breathing or approved cardiopulmonary resuscitation (CPR), as appropriate, until medical help arrives and takes over.
6. Investigate source of CO and take corrective action.

### NOTICE

*Prompt action can make the difference between life and death.*

## G. Inspection

Look and listen for leaks in the exhaust systems of both the generator (if applicable) and propulsion engine(s). Look for discoloration around joints in the system (water leaks, carbon, stains, etc.).

1. Make sure all exhaust clamps are in place and secured.
2. Make sure ventilation systems work and are not obstructed or restricted.
3. Make sure gaps around the engine room plumbing and cableways and exhaust system doors, hatches, and access panels are minimized to reduce the opportunity for CO to enter the accommodation space(s).

## H. Operation

Cold Start vs. Warm Start: CO production is greater while the combustion chamber surfaces and gas passages are cold versus when they are warm. A boat operator should:

1. Pay attention to ventilating the boat.
2. Orient the boat so it will allow the maximum dissipation of CO.

3. Minimize the time spent on getting underway.
4. In order to minimize CO buildup, do not warm up or run propulsion engine(s) for extended periods while the vessel is stationary.



*The following are examples of possible situations where carbon monoxide can accumulate within your boat while docked, anchored, or underway. Become familiar with these examples and their precautions to prevent **dangerous** accidents or death.*

## I. Boathouses, Sea Walls and Confined Spaces

A boat operator should be aware that dangerous concentrations of CO can accumulate when a boat, generator or other engine operated device is operated while the boat is moored in a confined area such as:

1. Boathouses,
2. Proximity to sea walls, or
3. Proximity to other boats.

Keep engine room hatches and doors closed when operating engines, including the generator (if applicable).

Pay attention to prevailing conditions and provide for ventilation to induce fresh air and minimize exhaust re-entry. Orient the boat for maximum dissipation of the exhaust. **DO NOT** run the boat or boat equipment for extended periods under these conditions. See Figure B6.



**Figure B6: Minimize Exhaust Re-entry**

Be aware that cockpit and deck drains can be a source of CO ingress into boats, especially boats with cockpit or decks enclosed with canvas or permanent boat structures.

## J. The Effect of Boats Moored Along Side

A boat operator should be aware that carbon monoxide is emitted from any boat's exhaust. The operation, mooring, and anchoring in an area containing other boats may be in an atmosphere containing CO not of the operator's making. An operator likewise needs to be aware of the effect of their boat on other boats in the area. Of prime concern is the operation of an auxiliary generator where boats are moored along side each other. Be aware of the effect your exhaust may have on other boats and be aware that the operation of other boats' equipment may affect the carbon monoxide concentration on your boat. See Figure B7.



**Figure B7: The effect of boats moored along side**

## K. Backdrafting (Station Wagon Effect)

Backdrafting or the "station wagon effect" is caused by air movement over or around a boat creating a low pressure area or suction area around the stern that can increase CO level on the boat. Backdrafting can be affected by relative wind direction, boat speed, and boat trim angle. See Figure B8 Backdrafting – Airflows Over Boat and Behind Transom".



**Figure B8: Backdrafting - Air flows over boat and behind transom**

Under certain speed and operating conditions, the low pressure area may form in other regions and permit carbon monoxide to enter the hull through openings that are not on the back of the boat. Boat factors which may affect CO concentration:

1. Intentional or unintentional excessive trim angle causing high bow angle. See Figure B9.

2. Excessive or unequally distributed weight.



**Figure B9: Inefficient trim angles**

3. Canvas configurations – Under various conditions, adding or removing canvas may raise or lower CO levels. See Figures B8, B9 & B11.



### EXHAUST FUMES!

Hull exhaust from your boat can cause excessive accumulation of poisonous carbon monoxide gas within cockpit areas when using protective weather coverings (while underway or while stationary). Provide adequate ventilation when the canvas top, side curtains and/or back (aft) curtains are in their closed protective positions.

4. Opening and closing ports, hatches, doors, and windows may raise or lower CO levels on board a boat. When airflow is moving forward inside the boat, CO may be entering the boat. See Figures B10 and B11.



**Figure B10: Desired air flow through the boat**



**Figure B11: The effect of canvas configurations**

5. Operating a boat at slow speeds with a following wind should be avoided. Consider changing direction, adjusting speed, or both. See Figure B12.



**Figure B12: Operating at Slow Speed with Following Wind**

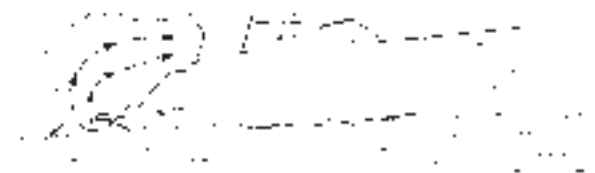
6. Be aware that cockpit and deck drains can be a source of CO ingress into boats, especially boats with cockpit or decks enclosed with canvas or permanent boat structures.

#### L. Accumulation of Exhaust Gases - Swim Platform

When the propulsion engine(s) or generator is running, CO is produced and may remain in the vicinity of the exhaust outlet (including underwater exhaust outlets).

1. Do not occupy aft lounging area(s) or swim platform.
2. Do not swim under or around swim platform.
3. Do not swim in the vicinity of the exhaust outlet.

Refer to Figure B13.



**Figure B13: Exhaust Gas Accumulation at Swim Platform**

#### M. Dangerous Activity - “Teak Surfing”/“Dragging”

Do not sit on, occupy or hang on any stern appendages (e.g., swim platforms, boarding ladders, etc.) while underway. Do not body surf, commonly known as “teak surfing” or “dragging”, etc., in the wake of the boat. Do not tow persons in close proximity to the stern of the boat. See Figure B14. This activity can also increase the possibility of injury due to contact with a rotating propeller.



**Figure B14: Exhaust Gas Accumulation - Dangerous Activity**

#### N. Cabin Appliances

Boats having fuel burning appliances in accommodation areas should be provided with adequate ventilation and the appliance should be maintained to function properly.

#### O. Air Conditioning (Applicable Models Only)

Lack of system maintenance may cause CO to be brought into the air-conditioned spaces by the air conditioner. If applicable, please refer to the air conditioner manufacturer’s literature for additional information. Please consult with your Four Winns Dealer regarding availability.

#### P. Ventilation of Accommodation (Occupied) Spaces

Accommodation spaces need to be ventilated to introduce fresh air into the spaces. Ventilation methods (e.g., windows, hatches, doors, and blowers) used to accomplish this may, under certain conditions, bring hazardous levels of CO into the occupied spaces. Care should be taken to be aware of all prevailing conditions when using these ventilating methods.

#### Q. Running of Engines in Idle

Engines running in idle exhaust carbon monoxide that can accumulate near the hull of the boat. Do not stand or swim near the engine exhaust or outrdrive when engines are idling or generator is running.

#### R. Altitude and Sea Conditions

Operation at altitudes greater than 5,000 feet contributes to inefficient engine performance and may require adjustments to the ignition systems, fuel systems, or changing the propeller’s size or gear ratio.

1. Failure to make adjustments to ignition systems and/or fuel systems for altitude conditions may cause an increase in CO production.

2. Reduced power resulting from increased altitude may require adjustments to propeller size.
3. Heavy sea or out of trim conditions tend to load engines resulting in reduced performance and thereby increasing their CO production.

#### S. Portable Generator Sets



*Never use a portable generator on a boat.*

Gasoline-powered portable generators are available in the marine market place and are not an option available through Four Winns. Portable generators will produce CO. These sets discharge their exhaust products in locations which can lead to an increase in the accumulation of carbon monoxide in the accommodation occupied space. **Do not use gasoline-powered portable generators on Four Winns® boats.**

#### T. Maintenance - Engine Performance

Efficient engine performance is vital to minimizing CO production. The following items are those considered to have the greatest effect on increased CO production:

1. Fuel Systems - Fuel that is contaminated, stale or incorrect octane number
2. Carburetors/Injectors
  - a. Dirty or clogged flame arrester
  - b. Malfunctioning automatic choke plate or faulty adjustment of manual choke plate
  - c. Worn float needle valve and seat
  - d. High float level
  - e. Incorrect idle mixture adjustment
  - f. Dirty or worn injectors
3. Ignition System
  - a. Fouled or worn spark plug.
  - b. Worn points or incorrect gap on points

- c. Shorted or opened circuit high tension spark plug cables
- d. Incorrect ignition timing.

#### 4. General

- a. Worn piston rings and valves
- b. Engine temperature - Cold running engines increase CO production. Engine cooling water system design and selection of thermostat(s) are primary considerations affecting engine operating temperature. Generally, an engine produces less CO if it operates at a relatively high temperature within manufacturer's specifications.
- c. Exhaust Back-Pressure - Certain alterations to the exhaust system may increase engine exhaust back pressure and CO production.
- d. Restricted engine room or compartment ventilation

#### U. Maintenance - External Conditions

External conditions that contribute to inefficient engine performance can include:

1. Fouled hull bottom
2. Damaged and fouled running gear (i.e., outdrive shaft, strut propeller, rudder and trim tabs, if applicable)
3. Incorrect selection of propeller size

#### V. Maintenance - Exhaust System Integrity

Gas tight integrity of exhaust systems must be maintained to insure that leakage of CO within the boat does not occur. Disassembly may be required to carry out a thorough inspection. Repair or replace components as indicated. Inspect the following:

1. Gaskets at cylinder head connection
2. Casting and pipe fittings in the dry section
3. All joints
4. Hoses



5. Clamps
6. Mufflers and their drain plugs
7. Thru-hull fittings
8. Hangers and other supports

#### **W. Maintenance - Ventilation Systems**

Boats are equipped with ventilation systems to eliminate gasoline vapors. Blowers and fans may also be provided for ventilation and to mitigate the migration of CO into occupied compartments. Attention should be paid to the following:

1. Keeping ventilation intakes clear of debris
2. Replacing damaged hardware
3. Maintaining the integrity of the duct material and its connections
4. Ensuring that position of duct intakes are not obstructed or restricted, collapsed, kinked, or crushed
5. Eliminating sags in ducts that can form a water trap
6. Checking hangers and other supports
7. Ensuring blower/fan is operational
8. Ensuring that airflow is present at discharge
9. Inspecting wiring to equipment

#### **X. Maintenance - Bulkhead and Deck Integrity**

1. Seal all visible openings (e.g., cracks, crevices, holes, including openings around wiring and piping runs) in bulkheads and decks that separate machinery compartments from occupied compartments. These openings can permit migration of CO vapors.
2. Check gaskets and sealing surfaces on hatches, doors, and access panels.

#### **Y. Maintenance - Air Conditioning Systems (Applicable Models Only)**

These systems can be a source of CO ingress and migration of CO vapors.

1. Keep grilles and filters clean.
2. Seal bulkhead voids and openings at wiring and piping runs in return air ducts, plenums, and air handling equipment enclosures, especially those adjacent to machinery compartment bulkheads.
3. Check that water traps and condensate drains are present. These may be in the form of a double loop in the drain line or prefabricated p-traps. Any drain that discharges below the waterline when the boat is underway is sealed, by virtue of its design, against CO intrusion.

#### **Z. Maintenance - Liquid Drains**

Sink, shower and condensate drains can be a source of CO ingress. Ensure that water traps are present and contain fluid. These traps may be in the form of a double loop in the drain line or prefabricated p-traps. Any drain that terminates below the waterline is, by virtue of its design, sealed against CO intrusion. Some drains that are below the waterline when boat is underway will be above the waterline when the boat is at rest. The location of drains, relative to the waterline, can be affected by the dynamics of boat motion (i.e., underway or at rest).

#### **AA. Carbon Monoxide Detection Systems**

Four Winns has installed a CO monitor in the berthing space(s). This piece of safety equipment could mean the difference between life and death. Check monitor and maintain in accordance with the manufacturer's instructions.



*Never disarm a CO detector. If a CO detector alarms, immediately ventilate the area and check passengers for symptoms of CO intoxication. See your Four Winns dealer for assistance in diagnosing the cause for the alarm.*

### NOTICE

*For information on CO Detection Systems, see American Boat and Yacht Council (ABYC Manual) Section A-24, "Carbon Monoxide Detectors".*

Even with the best of boat design and construction along with the utmost care in inspection, operation, and maintenance of boat systems, hazardous levels of CO may still be present in accommodation spaces and exterior areas under certain conditions. Vigilant observation of passengers for CO sickness symptoms should be supplemented by a marine CO detection device in the accommodation space.



*A CO detector is not a gas/fuel vapor detector. Gas/fuel vapor detectors do not monitor the buildup of carbon monoxide in an enclosed area. For further information on the design, construction, and testing of boats in consideration of carbon monoxide, see ABYC TH-23.*

### NOTICE

*Detection devices shall meet the requirements of ABYC A-24 "Carbon Monoxide Detection Systems on Boats".*

## B - 3 SAFE BOATING PRACTICES

### NOTICE

***YOU** are responsible for your own safety, the safety of your passengers, and the safety of fellow boaters.*

### A. Drugs and Alcohol



*Alcohol consumption and boating do not mix! Operating under the influence endangers the lives of your passengers and other boaters. Federal laws prohibit operating a boat under the influence of alcohol or drugs.*

Do not use drugs or drink alcohol while operating a boat. Like driving a car, driving a boat requires sober, attentive care. Operating a boat while intoxicated or under the influence of drugs is not only dangerous,

but it is also a Federal offense carrying a significant penalty. These laws are vigorously enforced. The use of drugs and alcohol, singly or in combination, decreases reaction time, impedes judgement, impairs vision, and inhibits your ability to operate a boat.

### B. Safe Operation

Safe operation means that you do not misuse your boat nor do you allow your passengers to do so. Safe operation means using good judgement at all times. It includes, without limitation, the following actions:

- Observe all safety signs and warnings both inside the boat and in the immediate boating area.
- Become familiar with and adhere to the "Rules of the Road".
- Maintain boat speed at or below the legal limits. Avoid excessive speed or speeds not appropriate for operating conditions.
- Be sure at least one other passenger is familiar with the operation and the safety aspects of the boat in case of an emergency, and knows how to use and locate all safety equipment.
- Load the boat within the limits listed on the capacity plate. Balance loads bow and stern and port to starboard. Passengers are to sit only on seats, not seat backs, gunwales, engine cover, or any other unsafe locations.
- Do not use the boat in bad weather or sea conditions beyond the skill or experience of the operator or the comfortable capability of the boat or passengers.
- Make sure the passengers and gear do not obstruct the operator's view or impede his ability to move.
- Do not exceed the maximum engine power rating stated on the certification plate located inside the boat.

### C. Passenger Safety

Before getting underway, show all passengers where emergency and safety equipment is stowed, and explain how to use it. Everyone aboard should wear rubber-soled shoes which resist slipping on wet

surfaces. While underway, passengers should remain seated inside the deck rails and gates. Do not allow passengers to drag their feet or hands in the water. Always use hand holds and other safety hardware to prevent falls. All non swimmers, poor swimmers and small children should wear PFDs at all times.

#### D. Propeller



##### **PERSONAL INJURY**

*Do not allow anyone near a propeller, even when the engine is off. Propeller blades can be sharp and continue to turn even after the engine is shut off. Do not allow anyone near the propeller when the throttle is in neutral position. Accidentally engaging the shift can result in a serious injury or death. (See actual ladder warning labels and helm boarding ladder warning label below).*



*Never approach or use ladder when motor is running. Severe injury or death will result from contact with rotating propeller.*

##### **Ladder Warning Label**



*Shut off motor when near swimmers. Severe injury or death will result from contact with rotating propeller.*

##### **Helm Boarding Ladder Warning Label**



*When pulling skiers do not turn on the engine until you are at least a boat length away from the person in the water. When approaching a downed skier, turn off the engine at least one boat length away before reaching the skier in the water.*

#### E. First Aid

As a boater, you should be familiar with the basic first aid procedures that may be needed while you are out far from help. Fish hook accidents or minor cuts and abrasions may be the most serious mishaps on board a boat but you should also learn the proper procedures and be ready to deal with the truly serious

problems like mouth-to-mouth resuscitation, excessive bleeding, hypothermia, and burns. First aid literature and courses are available through most Red Cross chapters.

#### F. Operation By Minors

Minors should always be supervised by an adult whenever operating a boat. Many states have laws regarding the minimum age and licensing requirements of minors. Be sure to check local laws or contact the state boating authorities for information.

#### G. “Rules of the Road”

As a responsible boater, you must comply with the “Rules of the Road,” the marine traffic laws enforced by the US Coast Guard. Navigating a boat is much the same as driving an automobile. Operating either one responsibly means complying with a set of rules intended to prevent accidents. Just as you assume other car drivers know what they are doing, other boaters assume you know what you are doing. Information regarding navigational rules and the “Rules of the Road” are discussed in further detail in C-1 & C-2 of the next section.

#### H. Voluntary Inspections

State boating officials in many states or the US Coast Guard Auxiliaries offer courtesy inspections to check out your craft. They will check for compliance with safety standards and required safety equipment. You may voluntarily consent to one of these inspections, and you are allowed to make corrections without prosecution. Check with the appropriate state agency or the Coast Guard Auxiliary for details.

#### I. Safe Boating Courses

The local US Coast Guard Auxiliary and the US Power Squadrons offer comprehensive safe boating classes several times a year. You may contact the Boat/U.S. Foundation at 1-800-336-BOAT (2628) for a course scheduled in your area. Also contact the US Coast Guard Auxiliary or Power Squadron Flotilla for the time and place of their next scheduled class.

## B - 4 WATER SPORTS



### PERSONAL INJURY

*Four Winns® boats are not designed for and should not be used for pulling parasails, kites, gliders or any device which can become airborne. Use boat only for appropriate water sports. (See Preface for actual warning label).*

Water skiing, wakeboarding, kneeboarding, or riding a towed, inflatable apparatus are some of the more popular water sports. Taking part in any water sport requires increased safety awareness by the participant and the boat operator. If you have never pulled someone behind your boat before, it is a good idea to spend some hours as an observer, working with and learning from an experienced driver. It is also important to be aware of the skill and experience of the person being pulled. Always have a second person on board to observe the person in the water so the driver can concentrate on operating the boat.

### A. Water Sport Guidelines

Everyone participating in a water sport should observe these guidelines:

1. Allow only capable swimmers to take part in any water sport.
2. Always wear a personal flotation device (PFD) approved by the US Coast Guard. Wearing a properly designed PFD helps a stunned or unconscious person stay afloat.
3. Be considerate of others with whom you share the water.
4. Give immediate attention to a person who has fallen. He or she is vulnerable in the water alone and may not be seen by other boaters.
5. Approach a person in the water from the lee side (opposite the direction of the wind). **Turn off the motor at least a boat length from the person.**
6. Turn engine off and anchor before swimming.
7. Always participate in water sports in safe areas. Stay away from other boats, beaches, restricted areas, swimmers and heavily traveled waterways.

8. Swim only in areas designated as safe for swimming. These are usually marked with a swim area buoy (see Figure B15). Do not swim alone or at night.



**Figure B15: Swim Area Buoy**



### Rotating Propeller!

*Rotating propeller can cut or sever causing serious injury or death. Shut engine off and remove ignition key when anyone is swimming nearby. (See Section B-3D).*

9. Do not allow anyone near the propeller(s), even when the engine is off. Propeller blades are sharp and can continue to turn even after the engine is off. Stay at least 150 feet away from areas marked by diver down float. See Figure B16.



**Figure B16: Diver Down Float**

10. Do not drive the boat directly behind a water skier. At 25 miles per hour, the boat will overtake a fallen skier who was 200 feet in front in about 5 seconds.

### B. Water Skiing/Wakeboarding/Kneeboarding

The popular sport of water skiing has brought a special set of safety precautions to observe in boating. The following guides help prevent accidents while water skiing.

1. Water ski only in safe areas, away from other boats and swimmers, out of channels, and in water free of underwater obstructions.

2. Allow no one who can not swim to water ski. Skiers must wear a USCG approved flotation device. A Type III water-ski vest is an approved and practical PFD.
3. Have a second person aboard to observe the skier and inform the driver about the skier's hand signals (Figure B17). The driver must give full attention to operating the boat and the waters ahead.
4. Give immediate attention to a fallen skier. Be careful not to swamp the boat while taking the skier on board.
5. Always participate in water sports in safe areas. Stay away from other boats, beaches, swimmers, and heavily traveled waterways.
6. Be considerate of others with whom you share the water.
7. Give immediate attention to a person who has fallen. He or she is vulnerable in the water alone and may not be seen by other boaters.
8. Approach a person in the water from the lee side (opposite the direction of the wind). Stop the motor at least a boat length from the person.

9. Turn off engine and anchor your boat before swimming.



### Rotating Propeller!

*Rotating propeller can cut or sever causing serious injury or death. Switch engine off before skiers enter the water and before taking skiers aboard. Do not leave engine running in neutral. Accidentally engaging shift can seriously injure skier.*

10. Do not water ski between sunset and sunrise. It is illegal in most states.

For more information about waterskiing, wakeboarding, and/or kneeboarding, please visit the American Water Ski Association, at their website: [www.usawaterski.org](http://www.usawaterski.org).

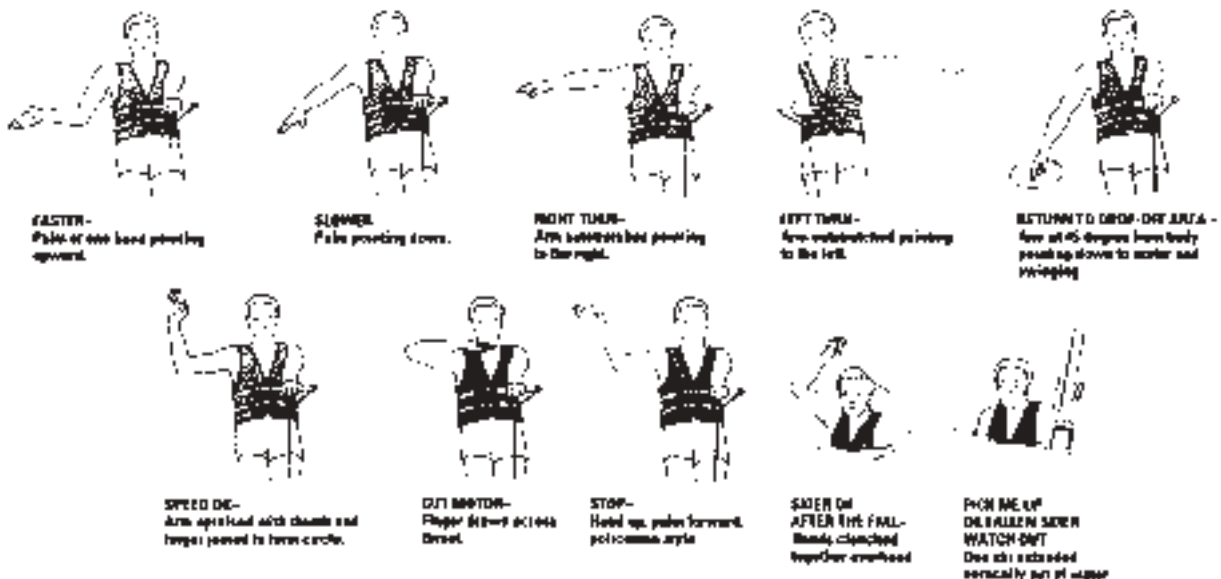


Figure B17: Skier's Hand Signals

## B - 5 HYPOTHERMIA

Hypothermia is a significant cause of deaths in boating accidents and should be taken very seriously. It occurs when the body is unable to generate enough heat to overcome the body's loss of heat to the environment such as water. Should a man overboard situation occur immediate action is necessary. Typically, when an individual has been overcome by hypothermia, loss of consciousness will take place and drowning will then occur. The colder the water the quicker hypothermia can set in.

PFDs can increase survival time because of the insulation they provide. When operating in cold water (below 40°F (4.4°C) consideration should be given to using a coat or jacket style PFD as they cover more of the body than the vest style PFDs. Additional note: Certain types of pfd's allow for turning most unconscious persons in the water from face down position to a vertical or slightly backward, face-up position. These types may increase the chances for survival.

Points to remember should you find yourself in the water:

1. Conservation of body heat is vital! While afloat in the water, do not attempt to swim unless it is to reach a nearby boat, fellow survivor, or a floating object on which you can lean or climb. Unnecessary swimming increases the rate of body heat loss. In cold water, drown-proof method that require putting your head in the water are not recommended. Keep your head above the water. This will greatly lessen heat loss and increase your survival time.
2. Keep a positive attitude about your survival and rescue. This will improve your chances of extending your survival time until rescued. Your will to live does make a difference!
3. If there is more than one person in the water, huddling is recommended while waiting to be rescued. This action tends to reduce the rate of heat loss and thus increase the survival time.
4. Always wear your PFD. It won't help you fight off the effects of hypothermia if you don't have it on when you go into the water.

## C - 1 GENERAL

Basic rules of seamanship, general information about navigational aids, and sources for additional reading and boater education are presented in this portion of your owner's manual.

### A. Boating Regulations

The US Coast Guard is the authority of the waterways. State boating regulations are enforced by local authorities. Your boat is subject to the marine traffic laws known as "Rules of the Road," which are enforced by the US Coast Guard. You are subject to marine traffic laws and "Rules of the Road" for both federal and state waterways; you must stop if signaled to do so by enforcement officers, and permit them to board if asked. The "Navigational Rules, International-Inland Rules of the Road" can be obtained from the US Coast Guard website at [www.uscgoating.org](http://www.uscgoating.org).

Many pamphlets prepared by the US Coast Guard are available. They explain signal lights, buoys, safety, international and inland regulations and other information which goes beyond the scope of this manual. "Aids to Navigation" (US Coast Guard pamphlet #123) explains the significance of various lights and buoys. Because of proposed alterations to buoys and markers, contact the US Coast Guard or visit their website to stay informed of changes. Other pamphlets, including the "Boating Safety Training Manual" and "Federal Requirements For Recreational Boats," are also available from the US Coast Guard.

#### NOTICE

The spoken word "MAYDAY" is the international signal for distress. "MAYDAY" should NEVER be used unless there is grave or imminent danger, and you are in need of immediate assistance.

### B. Rules of Seamanship

#### 1. Right-of-way

In general, boats with less maneuverability have right-of-way over a more agile craft. You must stay out of the way of the following vessels:

A vessel not under command or aground.	These vessels have no maneuverability.
A vessel restricted in its maneuverability.	These vessels are performing work which limits their maneuverability such as surveying, dredging, laying pipe or cable, servicing navigational markers among others.
A vessel engaged in fishing.	These include boats fishing with lines, trawl or nets; but not trolling lines.
Sailboats	Sailboats have the right-of-way over power boats; however, if a sailboat is using a propeller to move forward, it is considered a power boat even if its sails are up.

#### 2. Meeting Head-On

When two boats meet head-on neither boat has right-of-way. Both boats should decrease speed and pass; port to port. However, if both boats are on the left side of a channel, each vessel should sound two short horn blasts and pass to starboard to starboard. See Figure C1.

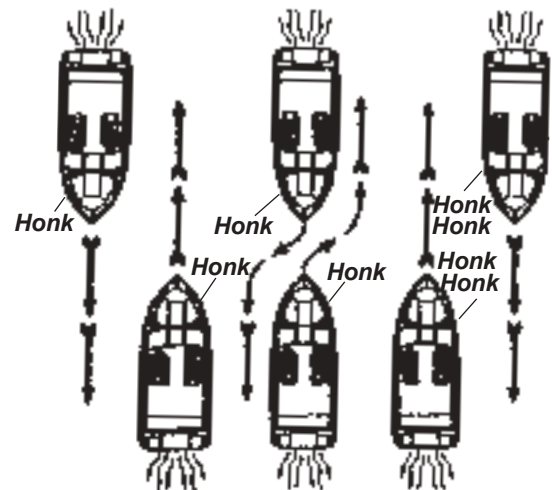


Figure C1: Meeting Head-On

#### 3. Crossing Situations

In a crossing situation, the boat on the right from the 12-4 o'clock position has the right-of-way. It must hold course and speed. The boat without the right-of-way must keep clear and pass to the stern. See Figure C2.

Stand-on (Privileged) vessel holds course and speed

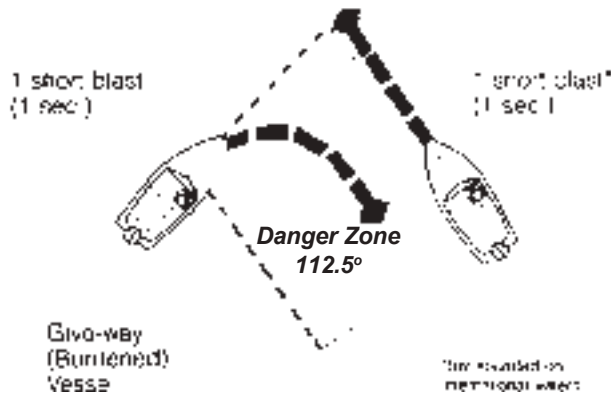


Figure C2: Crossing Situation

#### 4. Overtaking

The boat overtaking the one ahead must yield the right-of-way to the boat being passed. The overtaking boat must make necessary adjustments to keep out of its path. The boat being passed should hold its course and speed. See Figure C-3.

Inland Rules	Stand-on (Privileged) Vessel Being Overtaken	Inland Rules
"I want to pass you on your port side."		"I want to pass you on your starboard side."
2 short blasts (1 sec.)		1 short blast (1 sec.)
"Proceed"		"Proceed"
2 short blasts (1 sec.)		1 short blast (1 sec.)
International Rules		International Rules
"I am altering my course to port."		"I am altering my course to starboard."
2 short blasts (1 sec.)		1 short blast (1 sec.)
2 short blasts (1 sec.)		1 short blast (1 sec.)
International Rules in Narrow Channels		International Rules in Narrow Channels
"I intend to pass you on your port side."		"I intend to pass you on your starboard side."
2 prolonged blasts (4-6 sec.)		2 prolonged blasts (4-6 sec.)
2 short blasts (1 sec.)		1 short blast (1 sec.)
"Proceed."		"Proceed."
1 prolonged, 1 short		1 prolonged, 1 short
1 prolonged, 1 short		1 prolonged, 1 short
		1 prolonged, 1 short

Figure C3: Overtaking

#### 5. The General Prudential Rule

The general prudential rule regarding right-of-way is that if a collision appears unavoidable, neither boat has right-of-way. As prescribed in the "Rules of the Road", both boats must act to avoid collision.

#### 6. Night Running

Boats operating between sunset and sunrise (hours vary by state), or in conditions of reduced visibility, must use navigational lights. Nighttime operation, especially during bad weather or fog, can be dangerous. All "Rules of the Road" apply at night, but it is best to slow down and stay clear of all boats regardless of who has right-of-way.

To see more easily at night, avoid bright lights when possible. Also, it is helpful to have a passenger keep watch for other boats, water hazards, and navigational aids.

To determine the size, speed and direction of other vessels at night, you should use running lights. A green light indicates the starboard side, and the red light indicates the port side. Generally, if you see a green light, you have the right-of-way; if you see a red light, give way to the other vessel. See Figure C4.

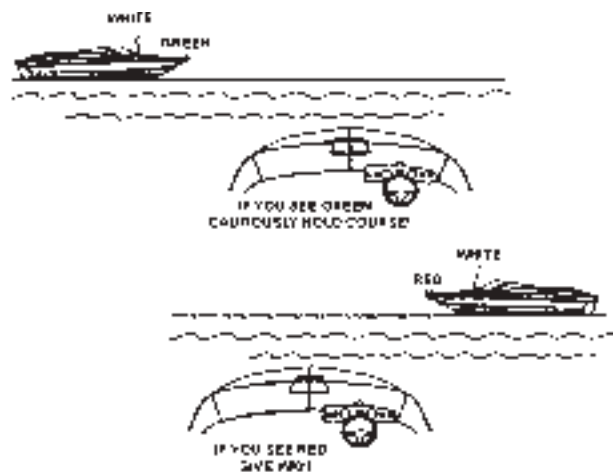


Figure C4: Night Running

#### 7. Whistle Signal

Out on the water, whistle signals are commonly used. Although using a whistle signal is not necessary every time a boat is nearby, operators must signal their intentions when necessary to avoid potentially confusing or hazardous situations. Use whistle blasts early enough to be noticed and understood by other boaters.

It is customary for the privileged boat to signal first and the yielding boat to return the same signal to acknowledge she understands and will comply. Use the danger signal (five or more short and rapid



blasts) if intent is not clear. A short blast is one or two seconds long. A long blast is 4 to 6 seconds long. The Navigational Aids Chart at the end of this manual lists the meanings of the various whistle signals.

## C - 2 NAVIGATIONAL AIDS

Aids to navigation (ATONS) help you to travel safely on the water. They help you get from one place to another and are most helpful if you have a nautical chart. A navigational aids chart is at the end of this manual (inside back cover).



*NEVER tie your vessel to an ATON. It is illegal because it blocks the ATON from view of other boaters. Decreased visibility can contribute to a serious accident which may result in property damage, personal injury, or death.*

There are two ATON systems. The system used on federal waters is known as the International Association of Lighthouse Authorities System B (IALA-B). The US Coast Guard maintains this system. The second system is the Uniform State Waterway Marking System (USWMS). This system is maintained by state authorities.

### A. International Association of Lighthouse Authorities System B (IALA-B)

IALA-B uses four types of ATONS. This section discusses the two most common markers: lateral markers and safe water markers. Other federal markers include special markers and isolated danger markers. The Navigational Aids Chart at the end of this manual shows these aids.

### B. Lateral Markers

Lateral markers indicate the sides of navigable channels. They consist of lighted can or nun buoys and daymarks. Each has a number and is either red or green. The numbers on the green markers are odd. Red markers have even numbers.

Buoys are red or green floating ATONS. If lighted, they have either red or green lights. Unlighted green buoys, called cans, look like cylinders. Unlighted red nun buoys have a cone shaped top with their points cut off. Do not pass too close to a buoy. You may foul the propeller in its chain.

### NOTICE

*Buoys are anchored floating objects and may not always be in exactly the same position.*

Daymarks are red or green boards with numbers. They are on posts or groups of pilings tied together and called dolphins. Daymarks and their supports are daybeacons. Daybeacons may or may not have lights. If a red or green daybeacon has a light, it is the same color as the marker-red or green. Red daymarks are triangular and have even numbers. Green daymarks are square and have odd numbers.

**Red Right Returning** is a basic rule to assist you in using lateral markers. When you are returning from seaward, keep red markers on the starboard (right) side when you pass them. Keep green markers to the port side.

Returning from seaward is very clear if you have been on the ocean. You are returning to port. By agreement, going upstream on a navigational river is returning from seaward. The outlet ends of the Great Lakes are also the seaward ends. Traveling from a large body of water to a smaller one is considered returning from seaward.

### C. Safe Water Markers

Safe water markers have vertical red and white stripes and mark the center of navigable channels and fairways. Safe water markers included both lighted and unlighted buoys and daymarks. If a marker is lighted, the light is white and flashes the letter "A" in Morse Code.

Preferred Channel markers have horizontal red and green bands. If lighted, the color of the light is the same as the top of the band. They show the preferred channel for you to use at a junction point. Be sure to notice the color of the top of the band, and treat it as any other marker you would of that color. If the band is red and you are returning from seaward, keep the marker to the right.

Most lights on markers flash on and off. Others such as lights on aids with no lateral significance are fixed. They stay on all night. ATON lights flash in regular patterns. For example, they may flash every three seconds, or in groups such as two flashes and a pause. There are a number of flashing patterns, which help you identify the light at night. To identify

a light, note its color and pattern or timing of flashes, and compare it to your chart to find its location.

#### **D. The Uniform State Waterway Marking System**

This section discusses three kinds of markers in this system: Regulatory, Informational, and Lateral.

Regulatory markers in this system are either signs or buoys. Signs are square with orange borders. Regulatory buoys are white and shaped like cylinders. They have horizontal orange bands near their tops and just above the water's surface. An orange circle on a marker means a controlled area. A message such as "No Wake, Idle Speed, No Skiing, or 5 M.P.H." may appear on a marker. An orange diamond means danger. If a diamond has an orange cross inside it, do not enter the area. The reason you should stay out, such as "Swim Area" may be printed in black on the marker.

Informational Markers are white signs with orange borders. They give information such as direction, distance, and location.

Lateral markers in the USWMS system are either numbered red or black buoys. Black buoys may have green reflectors or lights. They are the equivalent of green buoys in the IALA-B system. Red buoys may have red reflectors or lights. They are the same as red buoys in the IALA-B system. Red or black buoys are usually found in pairs – pass between them.

#### **E. A Special Sign**

In Florida, you may see a special sign: "Caution, Manatee Area". When you see this sign, slow down to idle speed. Manatees, an endangered species, are passive, large, slow-moving mammals. Many manatees are seriously injured or killed each year by boat propellers.

#### **F. Noise**

Always be aware of local laws on noise limits. Noise means engine noise, radio noise or even yelling by people on your boat. Good seamanship demands that you operate your boat quietly so as not to infringe on the rights of others. Do not use thru-hull exhaust unless you are well offshore.

### **C - 3 ANCHORING**

The weight of the anchor and diameter of anchor line should be governed by the size and weight of your boat. Keep anchor secure while underway to prevent damage or injury due to sudden shifting in the boat's attitude.

Use two or more anchors if anchoring overnight or for extended periods. If not using two anchors, make certain there is sufficient clearance for your boat to swing in a full circle to prevent damage in case of shifting winds.

Make certain you have enough anchor line (or scope) for the depth of water. Your anchor line should be 6 to 7 times the depth of water anchored in. For example, if you are in 20 feet of water, use 120 to 140 feet of anchor line.



*Secure anchor line to bow eye or deck cleat.  
Never tie anchor line to a rail, rail fitting or other hardware not designed to support this stress.*

To drop anchor:

Approach your selected anchoring site from downwind and come to a dead stop over the spot where you want to drop anchor. Lower the anchor manually or by using the windlass if applicable.

Maneuver the boat slowly backwards until length of anchor line is 6 or 7 times the depth of the water.

Fasten the anchor line around the bow eye or deck cleat. Anchor flukes should dig in and catch. Watch for anchor drag by checking shoreline landmarks at the time the anchor is dropped and one-half hour later. If the boat has drifted away from these reference marks, the anchor is dragging and must be reset.

To weigh anchor:

Start the engine running before pulling in anchor.

Slowly maneuver the boat forward to reduce tension on the line and make retrieval of the anchor line easier.

Raise the anchor manually or by using the windlass if applicable. Make sure the chain stop is engaged if windlass is used. Properly stow anchor and anchor line.



*Always be sure to raise and secure the anchor prior to operating your boat. Failure to raise and secure anchor before getting underway could result in severe injury or damage to boat from rebounding anchor.*



*Always utilize the chain stop provided with the windlass/bow roller combination. The chain stop prevents the anchor from accidentally releasing while the boat is moving thus preventing damage to the boat or possible injury or death to individual(s) aboard the boat.*

If the anchor becomes stuck, attach the vertical line to the mooring cleat. Wave action on the bow may lift flukes from the bottom and free the anchor. If the anchor is still stuck, feed out a few feet of line and attach it to the bow cleat. Maneuver the boat around the anchor, keeping the line firm. Determine the angle that will work to pull the anchor free.

Anchors are available in different shapes, sizes and weights to fit different boats, uses, and conditions. Your Four Winns dealer can tell you which anchor will work best for your boat.

#### **C - 4 RECOMMENDED READING**

We recommend that you read the boating literature published by your state boating agency and the US Coast Guard. Other suggested reading includes the following:

Damford, Don. Anchoring. (ISBN 0-915160-64-1). Seven Seas.

United States Coast Guard Auxiliary. Boating Skills and Seamanship. LC74-164688.(illus.). (ISBN 0-930028-00-7). US Coast Guard.

Bottomley, Tom. Boatman's Handbook, (illus.). 316 p. (ISBN 0-688-03925-1, Hearst Marine Book). Morrow.

Whiting, John and Bottomley, Tom. Chapman's Log and Owner's Manual. 192 p.(ISBN 0-686-96737-2). Hearst Marine Book.

Chapman, Charles F. and Maloney, E.S. Chapman's Piloting, Seamanship and Small Boat Handling. (illus.). 62 p. (ISBN 0-87851-814-2, Pub. by Hearst Bks.); deluxe ed. (ISBN 0-87851-815-0). Morrow.

National Fire Protection Association. Fire Protection Standard for Pleasure and Commercial Motor Craft. (ISBN 0-317-07388-5, NFPA 302). National Fire Protection Association.

Brotherton, Miner. Twelve-Volt Bible. (ISBN 0-915160-81-1). Seven Seas.

#### **C - 5 CONTACTS**

There are many good boating publications that have information about your area and what other boats are doing, such as clubs and other activities. Educational programs are sponsored by publications and organizations such as the US Power Squadron, US Coast Guard Auxiliary and the American Red Cross. See your dealer about special courses available in the area. For detailed information contact:

American Red Cross  
Local address (see local telephone directory)  
website: [www.redcross.org](http://www.redcross.org)

Boat U.S. Foundation for Boating Safety  
1 800-336-BOAT  
website: [www.boatus.com/courseline](http://www.boatus.com/courseline)

US Coast Guard Office of Boating Safety  
website: [www.uscgboating.org](http://www.uscgboating.org)

Skippers Course  
GPO Superintendent of Documents  
Washington, DC 20012  
202 512-1800  
202 512-2250 (fax)

United States Coast Guard Auxiliary  
Local Flotilla or contact appropriate Coast Guard District Headquarters  
website: [www.cgaux.org](http://www.cgaux.org)

United States Coast Guard Headquarters  
2100 2nd St., SW  
Washington, D.C. 20593-0001  
202 267-1060  
website: [www.uscgboating.org](http://www.uscgboating.org)

United States Power Squadron  
P.O. Box 30423  
Raleigh, NC 27617  
website: [www.usps.org](http://www.usps.org)

## C - 6 OWNER'S LOGS AND RECORDS

At the end of this owner's manual are several forms which you will find very helpful.

The **Float Plan** provides a record of your destination, departure and return times, boat description, passenger list, and other information about the trip you have planned. At the bottom of the form is space for listing emergency telephone numbers in case your return is delayed past the expected time. It also has space for indicating information about the person filing this report. Leave the completed form ashore with a responsible person. We recommend you make several copies of this form each boating season to assure an ample supply.

The **Fuel Log** is a handy way to record information covering engine hours, fuel consumption, miles traveled, as well as RPM (revolutions per minute), average MPH (miles per hour) and GPH (gallons per hour).

The **Service/Maintenance Log** provides a record of maintenance work completed, the date of completion, and the engine hour reading. This log also helps you identify the frequency of routine maintenance work, such as engine oil changes. If you should decide to sell your boat, it demonstrates to prospective buyers that you have done a good job taking care of it.

The **Service Information Sheet** allows you to record all the pertinent information regarding your Four Winns® boat. This sheet will be extremely helpful when ordering additional/optional parts for your boat or when having service work done.

## C - 7 NAVIGATIONAL AIDS CHART

The illustrated Navigational Aids Charts contain information concerning whistle signals, storm warnings, bridge signals, and buoy descriptions. See the inside back cover of this manual.



## **D - 1 FOUR WINNS WARRANTY POLICY**

The Four Winns Winning Edge™ Owner Protection Plan provides the new Four Winns purchaser with one of the most comprehensive corporate commitments in the marine industry today. The Winning Edge™ Owner Protection Plan defines the warranty coverage on all units manufactured by Four Winns. It thoroughly describes the warranty policies and those procedures to be followed to obtain warranty coverage. Review the Four Winns Owner Protection Plan and limited warranty statements carefully.

All engines utilized in the Four Winns® product are warranted by the engine manufacturer. Your Four Winns dealer is authorized to repair your engines and will work closely with the engine manufacturer to resolve any problems you have.

## **D - 2 DECK/HULL STRUCTURE WARRANTY**

Each unit manufactured by Four Winns is encompassed by a separate warranty providing specific coverage on the deck/hull structure. The Winning Edge™ Owner Protection Plan thoroughly describes this coverage.

## **D - 3 WARRANTY REGISTRATION**

A Four Winns Warranty Registration is attached to the Winning Edge™ Owner Protection Plan statement. Your Four Winns Dealer is responsible for completing and submitting the warranty registration at the time of purchase. The receipt of the warranty registration is the sole basis for establishing proof of ownership of the boat and corresponding warranty validation.

By signing the warranty registration you, the new owner, indicate an understanding of the terms and conditions of the Limited Warranty. The warranty registration should be properly completed by the dealer, signed by the new owner, and submitted to us via the Extranet within fifteen (15) days after the original purchase in order to validate the warranty. This is a dealership's responsibility. Be sure to keep a copy of the Owner's Registration for your records. All warranty registrations are performed on-line via the Extranet.

All boat manufacturers are required by The Federal Boat Safety Act of 1971 to notify first time owners in the event any defect is discovered "which creates a substantial risk of personal injury to the public." In order for us to notify you if necessary, be sure to verify the accuracy of the Winning Edge™ warranty registra-

tion upon receipt. You should receive your Winning Edge™ warranty registration at the time of delivery or within approximately 30 days from the day of your boat purchase. If you have not received your Winning Edge™ warranty registration within this time frame please contact your Four Winns selling dealer for resolution. If upon receipt of the warranty registration you discover a discrepancy, please notify Four Winns at 231 775-1343. The information will be corrected and a new copy will be supplied to you.

Other equipment manufacturers also require that their products be registered with their respective company. Warranty registrations are provided in the owner's information packet.

## **D - 4 TRANSFER OF WARRANTY**

Four Winns' confidence in the product and our warranty commitments can extend after the original purchaser may choose to move on to a new boat. The remainder of the Four Winns warranty coverage is transferable to the second owner of the boat for a fee. The warranty may be transferred only once. Registration of the second owner is required and the amount of the transfer fee is indicated on the warranty statement of the Warranty Registration . Transfer of the remainder of the warranty must occur within five (5) years of the original retail sale. The transfer fee must be paid within fifteen (15) days of purchase of the used boat by check, money order or cashier's check payable to Rec Boat Holdings, L.L.C. Proof of purchase date is required. The Winning Edge™ Owner Protection Plan thoroughly describes the action required to transfer warranty coverage.

## **D - 5 PRE-OWNED UNIT REGISTRATION**

Section D-4 Transfer of Warranty discusses the need to properly register the purchase of a pre-owned boat with Four Winns in order to transfer applicable warranty coverage.

Purchasers of all Pre-Owned Four Winns models, regardless of the decision to transfer warranty coverage, are encouraged to register ownership with Four Winns. To register ownership of a "Pre-Owned Four Winns® boat," provide Four Winns with your name, address, daytime phone number, e-mail address, purchase date, and hull serial number of the boat purchased. The hull serial number plate is permanently affixed to the starboard side of the transom. Registration of a Pre-Owned Four Winns® boat does not extend or in any way affect or modify the specific

terms of the Winning Edge™ Owner Protection Plan or Limited Warranties. We provide this service to the purchasers of Pre-Owned Four Winns® boats in the interest of better boating. Four Winns welcomes every purchaser of a Four Winns® boat, new or used, to our family.

## **D - 6 INSURANCE COVERAGE**

One of your responsibilities as a new boat owner is to acquire proper insurance protection. Insurance should include comprehensive and general liability coverage appropriate to your financial needs. Please contact your local agent for assistance on insurance coverage.

## **D - 7 SERIAL NUMBER RECORD**

The manufacturer, model, and serial number of major components are recorded during the assembly of each Four Winns® boat. A copy of this form is included in the owner's packet. Using this form, you may want to have your dealer help you complete the service information form at the back of this manual. A copy of the serial number record should be made and kept by the dealer in his records. This can assist the dealer in processing warranty claims, or obtaining necessary information. The original copy of the serial number record should be kept in the owner packet. The service information form should remain in the owners manual for easy reference.

## **D - 8 PRE-DELIVERY SERVICE**

Four Winns makes every effort to deliver your boat in "turn key" condition to the dealer. The process of transporting and handling the boat necessitates certain inspections and adjustments prior to delivery to you. Also, various aspects of operation must be checked and adjusted immediately prior to final delivery and use.

The selling Four Winns dealer must perform this thorough review of the boat and its numerous systems during the commissioning or "dealer pre-delivery service" of the craft.

A Four Winns Pre-Delivery Inspection Form is part of the Warranty Registration. It lists the many items encompassed by the pre-delivery service previously described. The dealer is to check off the items as they are completed, and complete the form as indicated providing specific performance related information appropriately.

Your Four Winns dealer will sign the Pre-Delivery Inspection Form of the Warranty Registration upon completion of the work. You will also be asked to sign the Pre-Delivery Inspection Form upon accepting delivery of the boat. You are to retain the two copies marked "Boat Owner". Your dealer is to retain the copy marked "Dealer copy" for his records. The manufacturer's copy is submitted on-line via the Extranet to the Four Winns Customer Service Department.

## **D - 9 REPLACEMENT PARTS**

Four Winns dealers have access to an electronic Four Winns parts manual that details the components of each model and their appropriate part numbers. Many Four Winns dealers inventory common replacement components.

In addition, Four Winns maintains specific records on the components used in the manufacture of each unit and makes a concerted effort to maintain components specifically to fill replacement part needs.

The Four Winns dealer from whom you purchased your boat is in the best position to meet your needs. If the dealer does not have the needed item, the dealer has the capability, through direct contact with the Four Winns Customer Service Department, to obtain it quickly. Four Winns will only sell replacement parts to established Four Winns dealers. If you relocate and cannot find a Four Winns dealer close to you, contact the Four Winns Customer Service Department for information on the nearest dealer in your area.

## **D - 10 OWNER'S RESPONSIBILITIES**

1. Sign the warranty registration verifying your address, model and hull serial number. The dealer is responsible for on-line submission of the warranty registration.
2. Inspect the boat at the time of delivery to verify that all systems and components are operating safely and acceptably. Read all manuals and instructions.
3. Operate all equipment in compliance with the manufacturer's instructions.
4. Review the pre-delivery checklist for the boat and engine with your dealer when you take delivery.

5. Schedule your 20-hour boat and engine checkup with your dealer.
6. Know how to safely operate your boat and the rules of the road before you use your boat.

**IMPORTANT:** Make sure that your dealer checks the engine alignment during your boat's 20-hour checkup. The engine alignment check should be performed in accordance with recommended procedures as stated by the engine manufacturer in your engine owner's manual. Failure to do so could result in drive train damage, which is not covered under the warranty.

7. We recommend that you review your engine owner's manual and warranty certificate for break-in advice, initial inspection and service requirements.
8. Perform or provide for the scheduled maintenance checks outlined in this manual and all related service guides and manuals.
9. You are responsible for any modifications made to the boat or its equipment that could affect the safe operation of the boat.

Along with boating, comes responsibility...responsibility for safety, boating laws, and the environment. Please think about the future of our waterways, oceans and marine life while you're out enjoying them and take all necessary measures to help protect what natural habitats we have left. Keeping our waterways and marine habitats free from debris, and showing consideration for the creatures who thrive in these environments are some ways you can help assure the pleasure of boating for years to come.

The operator is also responsible for complying with the following procedures and operational requirements:

- State registration
- Insurance
- Warranty registration
- Warranty terms and conditions
- Rules of the road
- Break-in procedure
- Proper maintenance of the boat and its systems
- Safety equipment
- Safety training of passengers and crews
- Knowledge of boat systems
- Seaworthiness/operational inspection
- Safe operating practices
- Avoiding use of drugs/alcohol

- Environmental regulations
- Accident reporting

## **D - 11 CONSTRUCTION STANDARDS**

All Four Winns® boats meet or exceed the construction standards set by the US Coast Guard and the American Boat and Yacht Council (ABYC) concerning:

- Navigational lights
- Factory-installed fuel systems
- Engine and fuel tank compartment ventilation
- Flotation
- Steering systems
- Backfire flame arresters

We recommend that you see your dealer if you wish to modify factory-installed equipment or add new equipment. Your dealer is qualified to make such modifications or additions without placing the safety or design integrity of your boat at risk and without invalidating the warranty.

## **D - 12 WINNGEAR**

Show your colors! Four Winns offers a complete line of sports clothing designed to complement your new boat. The WinnGear™ line is on display on our website at [www.fourwinns.com](http://www.fourwinns.com).

This page is intentionally blank.





Please place in envelope and mail to:  
Rec Boat Holdings, L.L.C.  
Attn: Four Winns Customer Service  
925 Frisbie Street  
Cadillac, MI 49601



## NAME / ADDRESS CHANGE FORM

Name & Address:

*Please print clearly.*

---

---

---

---

Telephone & E-mail Address:

---

Hull Identification Number:

---

Boat Model:

---

Date of Purchase:

---

NOTE: For warranty transfer please use the Warranty Transfer Request Form also included in this manual.

Please place in envelope and mail to:  
Rec Boat Holdings, L.L.C.  
Attn: Four Winns Customer Service  
925 Frisbie Street  
Cadillac, MI 49601



## NAME / ADDRESS CHANGE FORM

Name & Address:

*Please print clearly.*

---

---

---

---

Telephone & E-mail Address:

---

Hull Identification Number:

---

Boat Model:

---

Date of Purchase:

---

NOTE: For warranty transfer please use the Warranty Transfer Request Form also included in this manual.



## NAME / ADDRESS CHANGE FORM

Name & Address:

*Please print clearly.*

---

---

---

---

Telephone & E-mail Address:

---

Hull Identification Number:

---

Boat Model:

---

Date of Purchase:

---

NOTE: For warranty transfer please use the Warranty Transfer Request Form also included in this manual.

This page is intentionally blank.





Rec Boat Holdings, L.L.C., 925 Frisbie Street, Cadillac, MI 49601 Phone (231) 775-1343

## WARRANTY REGISTRATION TRANSFER REQUEST

Original Owner Name & Address:

---

---

---

Original Date of Purchase:

---

Hull Identification Number:

---

Boat Model:

---

Selling Dealer:

---

Name and address of new purchaser:

---

---

---

Telephone & E-Mail Address:

---

Date of Purchase:

---

The warranty may be transferred only once. Registration of the second owner is required and the amount of the transfer fee\* is indicated on the warranty statement of the Warranty Registration Card. Transfer of the remainder of the warranty must occur within five (5) years of the original retail sale. The transfer fee must be paid within fifteen (15) days of purchase of the used boat by check, money order or cashier's check payable to Rec Boat Holdings, L.L.C.

This warranty registration request if accepted, transfers the warranty coverage remaining on the boat to the new purchaser. Acceptance of this request does not create any additional warranties or obligation on Rec Boat Holdings, L.L.C.

Warranty Expiration Date:

---

Four Winns Transfer Acceptance Date:

---

Four Winns Authorized Signature:

---

Mail to: Rec Boat Holdings, L.L.C.

Attn: Four Winns Customer Service Department  
925 Frisbie Street,  
Cadillac, MI 49601

**\*Subject to change without notice.**

This page is intentionally blank.





### E - 1 GENERAL

#### NOTICE

*The information included in this section is general only. For specific operation of the engine(s) on your boat, refer to the engine manufacturer's literature (operator's manual) included in your owner's packet. Ensure you completely understand the operation procedures of the engine(s) before operating your boat. Also consult your dealer should any questions arise regarding the engine operation and/or maintenance.*



*DO NOT attempt to service any engine without being totally familiar with the safe and proper service procedures. Do not attempt to maintain or adjust an engine while it is running. Certain moving parts are exposed and failing to shut off the engine can result in serious injury or death.*

Four Winns does not manufacture engines or drives. Because of the technical nature of the engine and drive systems, all manufacturers of these items require that warranty and service problems be taken directly to an authorized dealer for resolution. The Four Winns dealer from whom you purchased your boat, will handle all warranty and service matters with the engine manufacturer for you.

In compliance with the Federal Boat Safety Act of 1971 all engine manufacturers require their products to be registered. A registration card is furnished with each new engine. When selling a Four Winns® boat, the dealer, along with the purchaser, should complete the information requested on these cards and return them to the respective engine manufacturers. Engine registration cards are provided with the engine and will usually be found with the boat literature.

Each manufacturer of the various marine power components provides an owner's operator's manual with their product. This publication is included with this manual. It is important that you read the manual(s) carefully and become completely familiar with proper care and operation of the engine and drive system. Be sure to read the section on winterization. Replacement costs associated with frozen engine blocks, drive systems and other components are quite substantial.

Also review the other sections in this manual, especially Section F on Control Systems and Section I on Fuel Systems.

### E - 2 ENGINE EXHAUST

#### A. Carbon Monoxide

The carbon monoxide in exhaust fumes can be hazardous. It is important for you and your passengers to be aware of the potential safety hazard created by exhaust fumes. Familiarize yourself with the symptoms of individuals overcome by carbon monoxide, and most importantly, ways you can protect yourself and your guests.



*DO NOT inhale exhaust fumes! Exhaust contains carbon monoxide which is colorless and odorless. Carbon monoxide is a dangerous gas that is potentially lethal.*

*Persons overcome by carbon monoxide may exhibit the following symptoms:*

- a. *Watering and itchy eyes*
- b. *Flushed appearance*
- c. *Throbbing temples*
- d. *Inattentiveness*
- e. *Inability to think coherently*
- f.  *ringing in the ears*
- g. *Tightness across the chest*
- h. *Headache*
- i. *Drowsiness*
- j. *Incoherence*
- k. *Nausea*
- l. *Dizziness*
- m. *Fatigue*
- n. *Vomiting*
- o. *Collapse*
- p. *Convulsions*

***IF YOU THINK EXHAUST FUMES ARE ENTERING YOUR BOAT, DETERMINE THE CAUSE AND HAVE IT CORRECTED IMMEDIATELY!***

The following suggestions can help prevent exhaust fumes from entering the boat or injuring people in the vicinity:

1. DO NOT allow the boat to remain stationary with the engines running for an extended period of time. Do not stand or swim near the exhaust output or drives when the engine is idling.
2. Use extreme caution while operating the engines in confined areas such as enclosed slips, congested piers, or in any area where the exhaust outlets are facing or near a bulkhead or wall structure of any kind. Operation under such conditions could easily lead to exhaust gases (carbon monoxide) entering even though you may have all the hatches, windows, doors and portholes closed.
3. Never operate your generator while the boat is moored against any other boat, dock or wall structure that is against or near the exhaust outlet. Again, operation under such conditions could easily lead to exhaust gases (carbon monoxide) entering your boat or the boat to which you are moored, even though you may have all the hatches, windows, doors, and portholes closed.
4. Under certain conditions, exhaust gases can enter the boat through the sink drains. Each sink drain has a water trap installed to help prevent this. To be effective, the sink drains must have water in them. Normal use of the sinks will provide the water needed for this to occur.
5. Persons sleeping can be easily overcome by carbon monoxide because they are unaware of its presence. Sleeping with the engines or generator running is not recommended. If persons are sleeping aboard while underway, or while the generator is running, those awake should monitor for carbon monoxide accumulation in the cabin; especially the sleeping areas. Open forward facing windows or deck hatches to provide fresh air ventilation. Keep hatches, windows, and doorways that face aft or towards the exhaust discharge closed.



*NEVER operate the propulsion engine(s) or generator while everyone on board is sleeping. Fatal carbon monoxide poisoning can occur.*

6. If possible, ventilate your cabin while under way. Open a forward hatch or window to allow air to travel through the cabin. Do not operate the boat with the cabin door(s) or windows that face aft, open. The natural vacuum created during operation may allow exhaust gasses to be drawn into the cabin.



**Carbon Monoxide - Cabin Doors Warning Label**

### NOTICE

*The forward deck hatch, portlights and port and starboard windows are designed to allow ventilation when placed in open position.*

7. Inspect the engine exhaust system frequently for water and exhaust gas leakage, hose deterioration, and loose hose clamps. See Section R - General Maintenance for additional information.
8. Have a certified marine engine service technician inspect your exhaust system whenever your boat is in for service, or if you notice a change in the sound of your engines.

For additional information, refer to Section B-2 - Carbon Monoxide.

### B. Carbon Monoxide Monitors

A carbon monoxide (CO) monitor(s) will sound an alert should carbon monoxide reach an unsafe level in the cabin. The CO monitors are standard equipment and are generally located in the aft cabin, forward cabin and main cabin. CO monitors locations will vary depending on V series model. Refer to the CO monitor's manufacturer literature included with the owner's packet.



*Never disarm a CO detector. If a CO detector alarms, immediately ventilate the area and check passengers for symptoms of CO intoxication. See your Four Winns dealer for assistance in diagnosing the cause for the alarm.*

## E - 3 ENGINE & DRIVE SYSTEM

### A. Engine

The V series models can be equipped with variety of different engine propulsion systems. Please consult the engine operator's manual provided in your owner's packet for operation and maintenance information.

### B. Stern Drives

A stern drive propulsion system has a piston engine equipped with special marine components mounted near the transom and coupled to an external outdrive-type transmission unit. Shifting is performed within the outdrive upper gear case. This type of system is depicted in Figure E1.

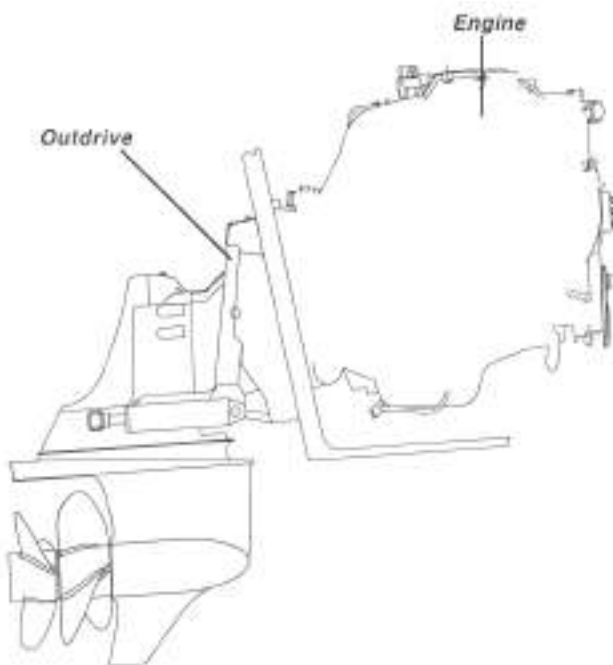


Figure E1: Stern Drive

### C. Volvo Penta IPS Drive-Units

The Volvo Penta Inboard Performance System (IPS) has twin drive-units that are steerable. These drive-units turn and point the entire thrust in the desired direction. The drive-units can be steered independently of one another. Each drive-unit is coupled to its respective diesel engine and shifting is performed within the drive-unit. The drive-units are mounted through the hull at the stern. This type of system is depicted in Figure E2.



Figure E2: Volvo Penta IPS Drive-Unit

#### NOTICE

To go from FORWARD to REVERSE, or REVERSE to FORWARD; always pause at NEUTRAL and allow engine speed to return to idle. **NEVER** shift the unit while engine speed is above 800 rpm.

#### WARNING

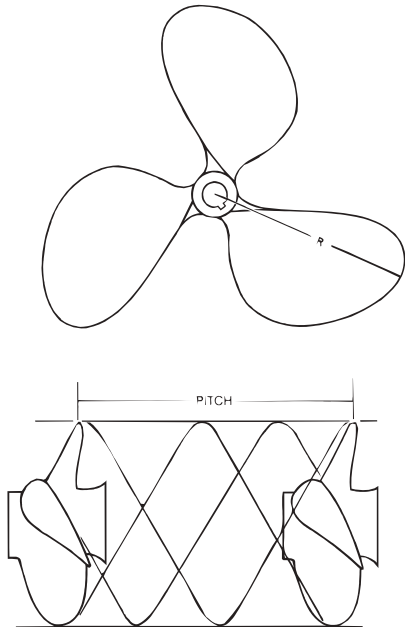
Avoid running aground or striking a (submerged) object. Serious damage to the engine(s) or IPS underwater gear can result and the boat can take on water. In the event of such an occurrence, proceed at low speed to the nearest service facility and have an immediate inspection made of the under-water gear before further use of the craft. Keep all life saving devices at hand while driving to a dock area. If the boat cannot be immediately removed from the water, thoroughly inspect the bilge area for leaks so that the boat does not sink while moored.

## E - 4 PROPELLERS

Knowledge of the propeller is most easily gained through better understanding of the terminology used to refer to the aspects of propeller size and performance.

### A. Diameter

Diameter is twice the distance from the center of the prop shaft to the extreme tip of a propeller blade. Increasing or decreasing propeller size will have a direct bearing on the RPM's an engine will develop. This is due to the greater amount of propeller blade surface in contact with the water. See Figure E3.



**Figure E3: Propeller Pitch & Diameter**

### B. Pitch

Pitch is a measure of helix angle, or angle of attack, of the rotating blade. Pitch is easily understood if one imagines the propeller rotating through a semisolid such as butter or gelatin. The distance the propeller will travel in one revolution is called "Pitch." Increasing or decreasing pitch will also have a direct bearing on engine RPM's because of the greater bite taken by the blade with each rotation. See Figure E3.

### C. Prop Slip

When traveling through water a propeller is unable to get a complete bite because of the fluidity of water. "Prop slip" is usually expressed as a percent of the computed theoretical speed. Twenty-five to thirty-five percent prop slip is common for a cruiser-type boat operating at cruising speed.

Changing either diameter or pitch will have an effect on engine speed and prop slip, and in turn, directly effect the performance of a boat. The propellers included with each Four Winns® boat provide the best general performance based on data obtained from on-the-water testing of that model. Variations in load, operating conditions, environment, the individual engine and hull performance may necessitate the purchase and use of another propeller(s).

Under your normal load conditions, the engines should turn within the maximum RPM range when at full throttle. If the engines exceed the recommended RPM, an increase in pitch or diameter is required. If the engine RPM is too low, a decrease in pitch or diameter is required.

The load carried in a boat will directly affect performance of the engine. If an engine that is not developing full power, be sure the engine is properly tuned and load conditions are those normally experienced, before changing propellers.

For shipping reasons, the propellers are not factory installed. Initial installation of the propellers will be performed by the dealer during pre-delivery service. Consult your specific engine manufacturer's owner's manual for propeller installation instructions. See Figure E3.

#### NOTICE

*Should it be necessary to change propellers, always use an appropriate propeller removal tool or "Prop Puller." DO NOT attempt removal using a hammer. Damage to the propeller or propeller shaft can result.*

Be sure the propellers are of the correct blade configuration, diameter, pitch, and shaft size to assure good performance. For additional information on factors affecting performance and/or assistance with your selection, please consult your Four Winns dealer.

#### NOTICE

*For twin engine installations, always check drive shaft rotation before propeller installation. A right hand rotation propeller must be installed on the starboard propeller shaft. Similarly, a left hand prop must be installed on the port propeller shaft.*

## E - 5 ENGINE COOLING SYSTEMS

### A. Raw Water Cooling

Certain stern drive engines utilize a raw water cooling system. This cooling system is a seawater system. Seawater (raw) water is taken in through water inlets on the both sides of the lower gear unit of the stern drives models. Water pumped to the engine by the seawater pump is circulated through the engine by the engine circulating pump. A thermostat controls the engine operating temperature by determining the



amount of water to be taken in, recirculated and discharged. On stern drive models, the water is discharged through an idle exhaust relief and the exhaust through the propeller hub. A temperature gauge(s) located on your instrument panel monitors engine(s) temperatures.



*Never operate your engine without a thermostat. Engine damage can occur and is considered operator negligence and therefore not covered under the engine warranty.*



*If engine should overheat, turn off engine, look for obstructions to water pick-up. If any obstructions are found, clear the obstructions and run engine again at 1500 RPM in neutral and check temperature gauge to verify condition. If overheating still occurs, return to port at low RPM to prevent excessive overheating and engine damage. Consult with your certified engine dealer for service.*

#### **NOTICE**

*When laying up the boat for winter it is important that the cooling system be flushed with fresh water so that deposits do not dry and to prevent the buildup of salt crystals. Please consult your engine owner's/operator's manual for proper engine and cooling system winterization procedures.*

## **B. Fresh Water Cooling**

IPS drives along with certain stern drive models include a "closed water cooling" system. The fresh water system is the engines' internal cooling system. The freshwater cooling system ensures the engine operates at the correct temperature. It is a "closed water cooling" system and **must** be filled with a mixture of at least 40% concentrated coolant and 60% water to protect against internal corrosion, cavitation and damage caused by freezing.

This system provides adequate engine cooling without exposing the internal engine to the detrimental effects of surface water, including salt, highly polluted or silt-laden water. The engine owners manual provides additional information regarding service and maintenance of this equipment.

Models that use fresh water cooling also use surface water as a cooling medium for the heat exchanger. This seawater system is the boat's external cooling system. Surface water may be used as a cooling medium for such items as the control system oil cooler, fuel cooler, intercooler, engine oil cooler and heat exchanger. Depending on the model, The cooling water employed enters the system through a water intake on the drive-unit or thru-hull water intake scoops. It is relinquished through the exhaust pipe elbow where it is mixed with the exhaust gases.

These types of intakes have an external strainer. Be sure strainers are kept free of mud, weeds and other debris. Some boating areas require that additional water intake filters be installed. Reference Section P-3 - Equipment Installation, in this manual for installation instructions and consult your Four Winns dealer regarding any special equipment that may be required.

A gate valve or seacock is provided at each engine intake scoop previously described. Be sure these valves are in the open position (lever is parallel with the valve) when operating the engines and in the closed positions (lever is perpendicular to valve) when engines are not operating for an extended period of time.



*Serious engine damage could result if seacock valve(s) is not open during engine(s) operation. Ensure seacock valve(s) are in the open position when operating engine(s).*



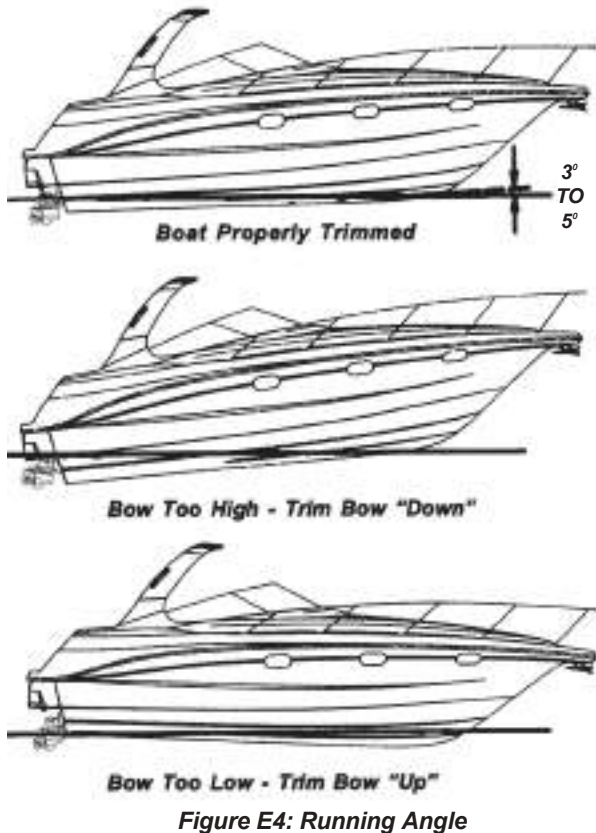
*Should an engine intake or an exhaust or cooling hose rupture, turn the engine off and close the seacock immediately. Proceed under tow if necessary to a service facility for appropriate repairs. Maintain a close visual watch on the problem hose and also on the bilge water level.*

## **E - 6 RUNNING ANGLE & POWER TRIM/TILT**

Hull planing surfaces have the least amount of drag at a three to five degree angle with the water. This is the preferred running angle when boating. The running angle has a significant impact on top speed and

handling. Heavy load or certain water conditions may make it difficult to achieve the optimum running angle. See Figure E4.

The running angle can be controlled through the use of power trim (stern drives) and/or trim tabs. See Section E-7 - Trim Tabs and Section T-7 - Trimming Your Boat for information on the use of trim tabs and tilt/trim control switches.



**Figure E4: Running Angle**

### A. Power Trim

Trim angle is how far in or out, the lower unit is positioned in relation to the bottom of the boat. The trim angle of the lower unit has a distinct affect on the running angle of the boat.

The power trim system permits control of the trim angle of the drive unit relative to the boat, at the touch of a button.

It allows the drive unit to be raised (trimmed out) for shallow water operation. Power trim also allows the operator to adjust the drive unit while underway to provide the ideal running angle for a given load and water condition. Additional information can be found in the engine owner's manual.

### B. Power Tilt

Power tilt allows the operator to raise and lower the drive unit for transporting, launching, and beaching. Additional information on power tilt can be found in the engine manufacturer's manual included with this manual.

#### NOTICE

*DO NOT operate the engine with the stern drive tilted up. Severe damage to the engine drive system can result. Consult the Engine Owner's manual for specific information.*

### E - 7 TRIM TABS

#### NOTICE

*The information regarding trim tab(s) operation is general in nature. Please consult the manufacturer's operations manual for specific information.*

Electric/hydraulic trim tabs are available for certain V series models. Trim tabs help provide maximum control of the hull in all water and load conditions. If used properly, trim tabs can:

- a. Compensate for wind and load listing (level the boat side to side).
- b. Induce faster planing and help achieve optimum running angle (see Section E-7 - Running Angle & Power Trim/Tilt).

The proper use of electric/hydraulic trim tabs requires a basic understanding of trim tab operation and some practice in calm water. The following discusses general trim tab operations. Your model may vary. Be sure to read the manufacturer's literature included in the owner's packet regarding the specific operating instructions of the trim tabs installed on your boat.

The trim tab control uses two (2) momentary-type rocker switches. The trim tab switches control the attitude or position of the boat. The trim tab switches are labeled by position such as "Bow Up" and "Bow Down". They are also labeled for "Port" and "Stbd". When pressed, the label indicates what happens to the bow of the boat.

Before leaving the dock and utilizing the trim tabs, ensure the trim tabs are in the full up position. Press both lower halves of the trim tab switches and hold (for approximately 10 seconds) until the tabs are full up.

### A. Control Listing

Wind, loading and many other factors can result in the boat tilting or leaning towards one side while running. This is called listing and can be negated using trim tabs.

Pressing the lower port trim tab switch will move the starboard trim tab upward. This will result in the port bow of the boat being allowed to rise.

Pressing the lower starboard trim tab switch will cause the port trim tab to move upward and will result in the starboard bow being allowed to rise.

Pressing the upper port trim tab switch will cause the starboard trim tab to move downward and will force the port bow downward.

Pressing the upper starboard trim tab switch will cause the port trim tab to move downward and will force the starboard bow downward.

Always establish your intended heading and attain desired cruising speed before trying to adjust running attitude (using the trim tabs).



*Always press the trim tab switches in short one (1) second bursts. If pressed too long, you can overcompensate, and potentially lose control. DO NOT try to correct the situation by pressing the other upper trim tab switch. Instead, raise the tab slightly by pressing the appropriate lower half of the trim tab switch.*

After stabilization of speed and direction, press the upper half of the appropriate trim tab switch to achieve a level side to side running attitude. Be sure to press the correct trim tab switch to obtain the desired result.

After pressing a trim tab switch, always wait and allow time for the change in trim tab position to take effect. DO NOT continue to press the trim tab switch while awaiting trim tab reaction. By the time the effect is noted, the trim tab will move too far and thus overcompensate.

### B. Induce Planing & Controlling Trim Angle

Trim tabs can also be used to facilitate faster planing and allow better control of the running angle.

Before accelerating and trying to gain plane, press both upper trim tab switches. This will cause both trim tabs to move downward and force the bow down when running. This can also be used when running the boat with a heavy load aboard.

Moving the trim tabs downward will increase the lift and the boat will achieve plane faster, or stay on plane at a lower engine and boat speed.

After gaining plane and establishing cruising speed, pressing both lower trim tab switches will cause both trim tabs to move upward and will allow the bow to rise. This should be used to adjust the running attitude of the boat to decrease the drag at cruising speed or above, or when running in a following sea.

When running at an engine speed that results in the boat falling off plane or causes the boat to plane inefficiently, lowering both tabs slightly (bow down) will improve the running angle and improve operating efficiency.

Optimum efficiency is obtained when operating at a 3 to 5 degree running angle. Utilizing too much "Bow Down" trim tab can reduce operating efficiency and cause substantial steering and handling difficulties. Be extremely careful when running in a following sea. The effect of trim tabs is amplified under such conditions. Steering and handling difficulties can result from improper trim tab usage, especially in a following sea. If unsure of proper trim tab positioning, raise the trim tabs to the full-up position.



*When running at high engine speeds, be sure the trim tabs are in the full up position. Trim tab action should be only enough to compensate for any listing. Trim tab adjustments at high speeds are extremely critical. Be prepared to slow down should handling difficulties arise.*

When running in a displacement (very slow speed) mode, better efficiency will be obtained with the trim tabs in the full-up position.

### C. Trim Tab Maintenance

Check the fluid level of the trim tab reservoir often. Always keep the fluid level between the designated marks on the trim tab pump-reservoir. Refer to the manufacturers information for specifications on the type of fluid to be used and other operation and maintenance information.

## E - 8 ENGINE INSTRUMENTATION

The helm station is equipped with a complete set of engine instruments. These instruments allow the pilot to constantly monitor the operational condition of the engine. Close observation of these instruments could save the engine from damage.

Many of the V series models have individual gauges in the dash panel. In this section we will discuss these various gauges and their functions. See Figure E5.



**Figure E5: V series Helm Station**  
(Representative View - Models May Vary)

### NOTICE

*Certain V series can be equipped with an Electronic Vessel Control (EVC) system, which includes a display panel. See Figure E6. The EVC system display panel shows operating information about the engine and allows you to communicate with the engine's electrical system. Due to the technical nature of this system it is imperative that you refer to the engine operator's manual and any other manufacturer's literature included in the owner's packet for exact operating instructions of the EVC system and display.*



**Figure E6: EVC System Display Panel**  
(Representative View - Models May Vary)

### A. Tachometer/Hour Meter Combination Gauge

The tachometer indicates the speed of the engine in revolutions per minute (RPM). This speed is not the boat speed or necessarily the speed of the propeller. The tachometer may not register zero with the ignition key in the OFF position.

### NOTICE

*Never exceed the maximum recommended operating RPM of your engine. Maintaining maximum, or close to maximum RPM for extended periods can reduce the life of the engine.*

Some engines are equipped with devices that limit engine RPM in accordance with the oil pressure, or engine temperature. Refer to the engine manual included in the owner's packet for additional information.

The tachometer must be set for different engines installed. This is typically done at the factory. The tachometer gauge is shown along with the table detailing the tachometer settings. See Figure E7.

## TACHOMETER SETTINGS



Set switch to match your engine.  
**CAUTION:** Depress switch slightly while turning.

TACHOMETER SETTINGS	
NUMBER OF CYLINDERS	ENGINE SETTING
4*	1
6*	2
8*	3
12 POLE	4
(OB ALT)	
* 4 CYCLE ONLY	

Note: Setting information is labeled on the back of the tachometer.

**Figure E7: Tachometer Settings**

The tachometer/hour meter combination gauge allows for hour meter viewing at the helm. See Figure E8. The hour meter provides a numeric record of elapsed engine operating time. This information is important in determining scheduled maintenance intervals, ship's log data, cruise information, etc.

The hour meter is connected to the ignition switch. Be sure the ignition switch is in the OFF position when the engine is not operating or the hour meter will record additional time. Note: If ignition key is placed in the ACC (Accessory) position the hour meter will not record additional time.



**Figure E8: Tachometer/Hour Meter**  
 (Representative View - Models May Vary)

## B. Speedometer

A speedometer may be available on certain V series models only. The speedometer is designed to be used like an automobile speedometer. See Figure E9.



**Figure E9: Speedometer**  
 (Representative View - Models May Vary)

Typically on those models that do not offer a speedometer gauge the ability to monitor your speed becomes available with a GPS/navigational package. Please refer to the manufacturer's literature for programming the GPS unit for speed readings. This information is included in the owner's packet when the boat is ordered with an available navigation package.

### NOTICE

*Speedometers/speed indicators are not precision instruments. The indications are relative and should never be used for navigational purposes or similar critical situations alone. Use other navigation systems in conjunction with the speedometer.*

### NOTICE

*DO NOT rely on the speedometer/speed indicator when trying to achieve a "NO WAKE" condition in a harbor or other enclosed waterway. Speedometers are not effective at measuring low operational speeds. ALWAYS be cognizant of the size of your waves your boat is making and reduce throttle until you are sure that they will not cause any damage. You are responsible for damage caused by the wake of your boat.*

The speedometer is a water pressure sensitive unit. It has a pick-up (pitot tube) assembly mounted in the outdrive assembly and a speedo tube connecting it to the speedometer gauge on the dash. Water strikes the tube inlet and creates positive pressure. The faster the boat speed, the greater the pressure, and the higher the speed indication on the speedometer.

### C. Temperature Gauge

On certain models the temperature gauge is in the “Four-in-One” gauge. The temperature gauge monitors the cooling system of the engine. A sudden increase in the temperature could be a signal of a blocked cooling passage or a water pump malfunction.

#### NOTICE

*Operation of an overheated engine can result in engine seizure. If an unusually high temperature reading occurs, shut the engine off immediately.*

### D. Oil Pressure Gauge

On certain models the oil pressure gauge is in the “Four-in-One” gauge. The oil pressure gauge indicates the pressure in the engine lubrication system. A drop in oil pressure is a possible indication of oil pump or leakage problems.

#### NOTICE

*Operation of an engine with abnormally low oil pressure can lead to engine damage and possible seizure. Have the engine serviced immediately upon a reduced oil pressure indication.*

### E. Voltmeter

On certain models the voltmeter gauge is in the “Four-in-One” gauge. The voltmeter monitors battery condition and thus alternator performance.

### F. Fuel Gauge

On certain models the fuel gauge is in the “Four-in-One” gauge. The fuel gauge displays the level of fuel that is present in the fuel tank. Refer to Section I - Fuel System for additional information.

Due to the mechanical nature of the fuel sender, variations in readings during various speeds of operation may occur. This system is merely a relative indication

of the available fuel supply and not a calibrated instrument. Refer to Section I-1G - Fuel Sender for additional information.

#### NOTICE

*Fuel gauges are not precision instruments. The reading is relative, and should never be relied upon as the sole indicator of fuel availability.*

#### NOTICE

*Use only clean, dry fuel of the type and grade recommended by the engine manufacturer. The use of incorrect or contaminated fuel can cause engine malfunction and serious damage. Refer to Section I - Fuel Systems for additional information.*

### G. Power Trim Gauge

Certain V series models equipped with stern drives have a “power trim gauges.” This gauge provides a visual indication of the inward-outward (trim angle) position of the outdrive. There is not a trailer travel mode on the gauge.

### H. Gas Vapor Detector

A gas vapor detector may be available on the certain V series models. If equipped, the gauge mounts in the dash. Additional information can be found in Section I-11- Gas Vapor Detector in this manual.

### I. Engine Hour Meter

Engine hour meters are available and provide a numeric record of elapsed engine operating time. This information is important in determining scheduled maintenance intervals, ships log data, cruise information, etc. The hour meter is located at the helm within the tachometer/hour meter combination gauge.

### J. Three Position Ignition Switch

On certain V series models, the ignition switch has three positions: OFF, RUN, and START. The START position is spring loaded and the key should be held in this position until the engine starts. The key will return to the RUN position once released. Always turn the key to the OFF position when the engine is not running. This will prevent discharging of the batteries. Additional information on ignition switch operation is covered in Section A - Operation of this manual.

## K. Four Position Ignition Switch

Other V series models, use an ignition switch with four positions: OFF, RUN, ACCESSORIES, and START. Just like the three position switch, the START position is spring loaded and the key should be held in this position until the engine starts. The key will return to the RUN position once released. Always turn the key to the OFF position when the engine is not running. This will prevent discharging of the battery(s). The ACCESSORIES position allows the operator to run the stereo without activating the other ship's systems. Additional information on ignition switch operation is covered in Section A Operation, of this manual.

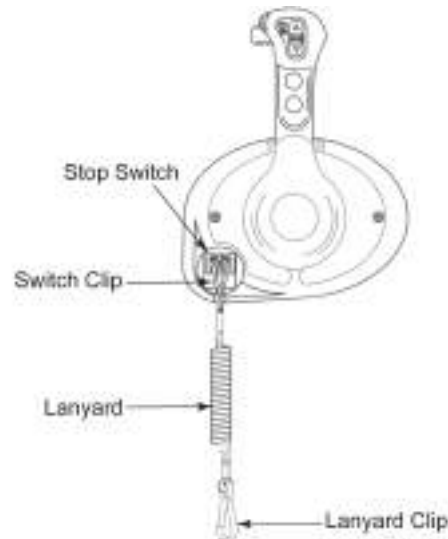
## L. Emergency Stop Switch

This safety device automatically stops the engine if the lanyard is attached to the operator and the operator falls from his helm station and may be installed on certain V series models. Refer to the engine manual for detailed information about using this switch.

The emergency stop switch (Figure E10) incorporates a shutoff switch, switch clip, lanyard, and lanyard clip. The lanyard clip must be securely attached to the operator's PFD, clothing, arm, or leg. Be sure to attach the lanyard to a place where it is free of obstructions and to something that will move with the operator if he or she leaves the helm station. If the engine shuts down because this switch was activated, the clip may have to be reinstalled on the interrupter switch before the engine can be started.



*Keep emergency stop switch lanyard free from obstructions that could interfere with its operation. Do not modify or remove emergency stop switch or bypass its safety features. The proper use of the emergency stop switch will prevent a runaway boat situation which can cause severe personal injury or death.*



**Figure E10: Emergency Stop Switch  
(Certain Models Only)**

The emergency stop switch can only be effective when in good working condition. Observe the following:

1. Lanyard must always be free of entanglements that could hinder its operation.
2. Once a month, check the switch for proper operation. With engine running, pull lanyard. If the engine does not stop, see your Four Winns Dealer.
3. Once a month, inspect both the clip and lanyard for cuts, breaks or wear. Replace worn or damaged parts.

In an emergency situation, any occupant of the boat can restart the engine. Just press in and hold the emergency stop switch button, then follow normal starting procedures. When the button is released, the engine will stop.



*Avoid knocking or pulling the clip or lanyard from the switch during regular boating operation. Occupants may be thrown forward or possible engine damage may occur by the sudden loss of engine power.*

## M. Alarm System

Certain V series models have an engine alarm system installed. This is an audible alarm that is mounted in the helm area; it is actuated by engine water tempera-

ture and engine oil pressure senders. The alarm will sound in the event of low engine oil pressure or high engine coolant temperature.

The engine alarm will sound during engine start-up, or whenever the ignition switch is positioned to ON and the engine is not operating. The alarm sounds under these conditions because engine oil pressure is low; the alarm will cease to sound as soon as engine oil pressure rises to the proper level.

### NOTICE

*The engine alarm monitors only engine water temperature and engine oil pressure. Always maintain a close visual watch on the drive(s), transmission(s), engine fluid levels, bilge water level, etc. Refer to the engine manufacturer's literature for additional information.*

## N. Navigational Equipment

Four Winns makes available navigational packages for its V series models. See Figure E11. Please consult the manufacturer's literature included in the owner's packet for operation and maintenance of these navigational systems (if applicable). Note: Equipment availability may vary. Please consult Four Winns dealer for equipment availability for your specific model.

### NOTICE

*Four Winns does not limit you to this specific navigational package mentioned above. There are many navigational systems on the market today. You may desire to use a different system based on your needs, personal preference, and mounting space available.*

### NOTICE

*Four Winns continually strives to improve its products. Unit specifications, including standard and optional equipment are constantly being modified. Equipment availability is also subject to change. The most current and accurate information available at the time of publication is included in this manual. Some variation in equipment, description, location, and details can result.*

### NOTICE

*These devices are only an aid to navigation. Their accuracy can be affected by many factors including equipment failure or defects, environmental conditions, and improper handling or use. It is the user's responsibility to exercise common prudence and navigational judgement. These devices should not be relied upon as a sole means of navigation nor as a substitute for such prudence and judgement.*



**Figure E11: Navigation Package**  
(Representative View - Models & Equipment May Vary)

### 1. Ship to Shore VHF Radio

A VHF radio is available on many of V series models.. It provides reliable communication between vessels, and from ship to public or private shore stations. It is programmed for two-way communication on all the International, US and Canadian channels plus reception on separate weather channels, and the international calling and safety channels (16/9). The VHF radio with microphone is mounted on the helm. If equipped, additional information is included in the manufacturer's literature included in the owner's packet.

### 2. GPS/Plotter/Radar

A GPS/chart plotter is an electronic system through which a navigator can determine his position regardless of weather. The GPS sensor receives high frequency radio signals generated from satellites to generate coordinate readings on the display. The GPS navigational unit takes this information and uses it to determine the vessel's exact position and indicates the vessels position on the chart plotter. The chart plotter allows one's course to be plotted



electronically. This factory installed GPS/Plotter system is available on certain V series models. It is mounted at the helm. If equipped, refer to the manufacturer's literature included in the owner's packet.

#### NOTICE

*You should not rely on these displays as your primary source of navigation. Rather, you should use the chart plotter as a backup to official government charts and traditional methods of navigation.*

Radar along with the GPS/Plotter may also be included in one of the navigation packages. The radar detects objects/targets and displays them for the operator to see. If so equipped refer to the manufacturer's literature included in the owner's packet for operation instructions.

### 3. Depth Sounder

A depth sounder may be included with the navigation package. Please consult the manufacturer's literature included in the owner's packet for operation and care of the particular depth sounder should it be installed.

### 4. Compass

A compass is available on certain V series models. See Figure E12. The compass can provide directional information when operating offshore, in unfamiliar waters, or in adverse weather conditions.



**Figure E12: Compass**

After all personal equipment is installed, including all electronics (VHF radio, GPS, chart plotter, etc.), the compass must be properly calibrated. DO NOT rely on the compass readings until initial adjustment (compensation) has been performed. The boat has a factory installed compass, the manufacturer's instructions are provided in the owner's packet. Most areas

have local companies that specialize in compass adjustment. If unsure of the proper compensation techniques, consider having the adjustment done professionally to insure accuracy and confidence in the compass.

#### NOTICE

*During use, keep all extraneous metal objects away from the compass. The close proximity of metal objects (e.g., beverage cans) can cause compass deviation.*

## E - 9 INSTRUMENT MAINTENANCE

Electrical protection for instruments and ignition circuitry is provided by a circuit breaker on the ignition panel. Periodically, spray the ignition switches with a contact cleaner. The ignition switches and all instruments, controls, etc. should be protected from the weather when not in use. Four Winns offers appropriate weather covers for each model. Excessive exposure can lead to gauge and ignition switch difficulties.



*DO NOT use a product such as WD-40 as a contact cleaner. Be sure to read the label before using any product.*

Electronic gauges are affected by static electricity that builds-up on the glass face. Periodic washing of the gauge face with clean warm water and mild liquid detergent will help eliminate the static electricity problem and improve gauge accuracy.



**F - 1 GENERAL**
**NOTICE**

*The control information included in this section is general only. For specific operation of the controls on your boat, refer to the control manufacturer's literature and engine manufacturer's literature included in your owner's packet. Ensure you completely understand the operation of the controls before operating your boat. Also consult your dealer should any questions arise regarding the operation of the control unit.*

Control systems permit operation of the engine's throttle and shift mechanisms. Typically, they consist of three major components; the control, the throttle and shift cables. Note: On models which include an electronic shifter the control cable is replaced by a CAN-bus type of electronic system. CAN stands for Control Area Network. Note: Controls will vary depending on the V series model and engine(s) selection.

V series single engine models are equipped with side mount control. See Figure F1. Stern drive models are also equipped with a trim switch which raise or lower the outdrive.



**Figure F1: Side-Mount Control - Single Engine (Representative Image only - Models may differ)**

V series twin engine models are equipped with a dual engine binnacle control. See Figures F2 and F3. On twin stern drive models the dual binnacle control has a trim switch(s) also. These trim switch(s) raise or lower the outdrives.



**Figure F2: Mercruiser's Dual Binnacle Control w/Trim (Trim Switches - Stern Drive Models Only)**



**Figure F3: Volvo Penta's Dual Binnacle Control w/Trim (Trim Switch - Stern Drive Models Only)**

**F - 2 CONTROL OPERATION**
**A. General**

On dual binnacle controls, the left lever controls the port engine and the right lever controls the starboard engine. Both the shift function and the engine speed are controlled by the lever control. Moving the lever forward will shift the drive into forward. Moving it aft will shift the drive into reverse. Moving the lever further will increase engine speed. See Figure F4.



**Figure F4: Electronic Control - Dual Binnacle IPS Control Shifter Shown - Models may vary)**

### NOTICE

Allow the engine to idle for the first ten seconds. Monitor all instruments and displays to ensure normal readings are shown. Check that no alarms are displayed and that no warning lights are flashing. Then warm the engine at low speed and low load until engine reaches normal temperature before full power is used.

## B. Shifting and Control Speed

1. Move shift/throttle lever(s) to the neutral idle position. Placing the shift/throttle levers in the neutral detent position will engage neutral start switch and allow engine to start. The engine can not be started if the control lever is in any other position but NEUTRAL. See Figure F5.



**Figure F5: Control Lever Positions - Dual Binnacle (Representative View - Models may vary)**

- N** - Neutral position. Drive-unit is disengaged and the engine runs at idle speed.
- F** - Drive-unit engaged for forward movement (ahead).

**R** - Reversing drive-unit engaged for rearward movement (astern).

**T** - Adjustment of engine speed.

### CAUTION

*DO NOT shift into FORWARD or REVERSE unless engine is running. Damage to the shift system could result from trying to shift without the engine running. Carefully check function of all control and engine systems before leaving the dock.*

2. To go FORWARD - move the shift/throttle lever(s) forward. Once forward gear engagement is complete, push shift/throttle lever(s) forward until desired speed is achieved.
3. To go in REVERSE - move the shift/throttle lever(s) rearward. Once rearward gear engagement is complete, push shift/throttle lever(s) rearward until desired speed is achieved.

### WARNING

*DO NOT shift from forward to reverse when the boat is planing.*

### CAUTION

*DO NOT shift if engine speed is above 1500 RPM. Shifting at higher engine speeds can place unnecessary stress on the drive-unit or cause engine to stop.*

4. To go from FORWARD to REVERSE, or REVERSE to FORWARD; always pause at NEUTRAL and allow engine speed to return to idle. **Note:** On certain controls, a beep will sound to indicate that the control lever is in NEUTRAL.

### CAUTION

*On a boat with twin engines it is important that both engines be running during reverse procedures, to avoid the risk of water entry (via the exhaust pipe) into a stationary engine.*

5. After shifting is completed, slowly push throttle lever(s) forward/rearward until desired speed is achieved.

 **WARNING**

*Any time the boat is operated, be aware of changes in shift system operation. A sudden increase in shift effort of the shifter levers, or other abnormal operation, indicates a possible problem in the shift system. If this occurs, the following precautions must be taken:*

- *With engine running and boat securely tied to the dock, shift drive into forward and reverse to ensure there is gear engagement.*
- *When docking the boat, all docking maneuvers must be performed at slow speed. Pay special attention to other boaters. Passengers should be informed of potential problems and precautions taken.*

If you suspect there is a problem, see your Volvo Penta® or MerCruiser® certified dealer as soon as possible for proper diagnosis and required service or adjustment. Continued operation could result in damage to the shift mechanism and loss of control.

### C. Engine Speed Synchronization

During the general operation of a twin engine boat, it is advantageous for both engines to be operated at the same engine speed (rpm). This reduces noise and vibration, and can increase propulsion system efficiency. Setting the throttles so the engines are running at the same rpm (synchronized) can be done by using the synchronization function (if equipped) on the electronic binnacle control. Follow the engine manufacturer's operating instructions regarding synchronization of the engines. These instructions are included in your owner's packet.

Attempting to synchronize the engines by manually controlling the throttle lever placement will generally not be effective. When the engines are in proper synchronization, the throttle levers may not necessarily be in the same position.

### F - 3 NEUTRAL SAFETY SWITCH

Every control system has a neutral safety switch incorporated into it. This device prohibits the engine from being started while the shift lever is in any position other than the neutral position. If the engine will not start, slight movement of the shift lever may be necessary to locate the neutral position and disengage the safety cutout switch. Should control adjustments be necessary they must be done by a authorized service technician.

### F - 4 JOYSTICK CONTROL

Joysticks are available on certain V series models. The joysticks are designed as a docking aid. It can be used for all your slow-speed maneuvering. The joystick allows the operator to maneuver and moor the boat in a simpler and safer manner. See Figures F6, F7 and F8. Refer to the engine operator's manual for specific instructions on the proper use of the Volvo Penta's "Joystick" or Mercruiser's "Axius" joystick.

 **WARNING**

*Learn to use the joystick control and its functions in a safe and correct manner before using at the dock.*



**Figure F6: Volvo Penta's "Joystick"**



**Figure F7: MerCruiser's "Axis" Joystick**

If the control units comes in contact with salt spray, simply wipe the affected surfaces with a clean cloth dampened with fresh water.



**Figure F8: Joystick Control**

*(Representative View Only - Models may vary)*

## F - 5 CONTROL SYSTEM MAINTENANCE

The electronic binnacle control and joystick control are designed to provide years of trouble-free operation with virtually no maintenance required. Do not attempt to repair these control units yourself. **Repairs must be performed by an authorized control service technician.**

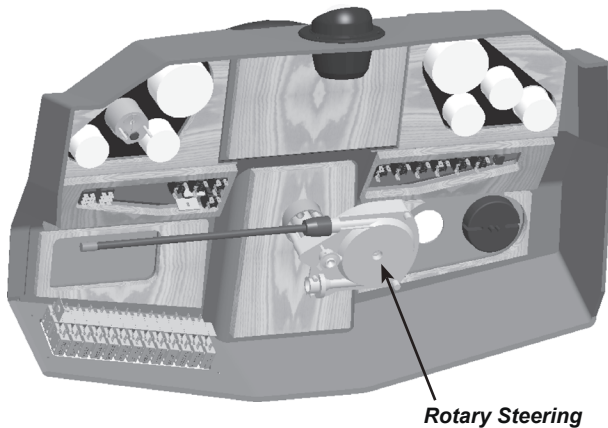


**G - 1 GENERAL**

Certain stern drive V series models are equipped with rotary-type steering systems. Certain V series may be equipped with an Electronic Vessel Control (EVC) system. Tilt and power steering are also available. Consult engine operator's manual and manufacturer's literature for further information regarding your particular steering system.

**A. Rotary Steering**

In the rotary system, a rotary drum assembly is mounted under the dash behind the steering wheel with a one-piece cable running through the boat into the engine compartment. At the transom, the cable turns and is connected to the drive tiller and the power steering unit. See Figure G1.



**Figure G1: Back of Helm Console**

**B. Power Steering - Stern Drive**

Power steering is available on certain V series models. It is comprised of an engine mounted pump, control valve, hoses, and steering cylinder. Power steering works in conjunction with the helm and steering cable to move the transom mounted tiller arm and vertical drive more easily.

This is a "power assist" system and can greatly reduce steering effort required. It is not, however, a full power steering system as is used in automobiles. Some steering tension remains in the system. Restricting movement of the steering cable will limit or stop the steering system's hydraulic assist.

**NOTICE**

*DO NOT interfere with or restrict steering cable movement through the last 90° of bend at the engine. DO NOT use cable retainers, clamps or tie straps. Using one or all of these could restrict the cable movement near the engine. DO NOT tie wiring harnesses or other control cables to the steering cable. Make sure the deck coaming pads and bulkheads allow for steering cable movement in all positions of trim.*

**NOTICE**

*When storing equipment in the engine compartment, be sure to avoid contact with the steering cable. Cables may become kinked or damaged and may increase steering effort.*

On twin engine installations, only the starboard engine is equipped with a power steering hydraulic assist unit. Therefore, when operating on a single engine, it is imperative to operate with the starboard engine. If only the port engine is used, hard steering will result.

Upon commissioning the boat, it is necessary to purge the system of air. This is performed by your Four Winns dealer during pre-delivery service. Should steering difficulty increase with time, it is possible additional bleeding of the system is required. See your Four Winns dealer for assistance. This and other adjustments on power steering units are critical and should be performed only by a qualified service technician.



*After the first two hours of running time, check the entire steering system for loose bolts, nuts and fasteners which could adversely affect steering control.*

If the power steering becomes inoperative, steering will be harder and more effort will be needed to steer the boat. Check for a broken or loose belt on the power steering pump. Also, low fluid levels in the power steering pump reservoir will cause hard steering. If these items are not the source of the problem, check for equipment or other items lying on or up against the steering cable at the back of the boat. The cable must be free and clear to slide back and forth. Any item blocking free movement of the cable will result in harder steering and possible damage to the steering cable.

If the power steering system cannot be corrected on board, proceed at a reduced speed. The boat will be steerable, but with increased effort. Contact your Four Winns dealer as soon as possible to correct the power steering system.

It is important that the power steering fluid be maintained at the proper level. Do not over fill the power steering pump reservoir. Please consult the section in the engine manual regarding steering system and maintenance. The engine manual is included in the owner's packet.

 **CAUTION**

*Check the power steering fluid level in the reservoir periodically. Low power steering fluid levels may increase steering difficulty.*

**NOTICE**

*DO NOT force the steering unit to either extreme. This can place undue strain on the unit and can lead to hydraulic line or seal failure.*

 **WARNING**

*Full lock when driving at high speed will make the boat turn strongly, which entails a great risk of personal injury, and/or people aboard may fall over or be thrown overboard. **Warn** everybody aboard before doing any emergency maneuvers.*

**C. Electronic Vessel Control (EVC)**

On V series models, where the steering system is operated through the Electronic Vessel Control (EVC) system, a smooth and exact steering is delivered. It offers steering capabilities which are not possible with traditional steering systems.

The helm steering unit sends an electrical signal via the EVC system to the servo unit steering (SUS) on the drive-unit. The electronic steering is progressive and the turn rate automatically adjusted to suit the actual boat speed for optimized comfort and boat handling. The wheel spins easier at low speeds, further reducing driver effort.

For reliability the steering system is built with redundancy on several levels. Consult engine operator's manual for specific information.

**D. Tilt Steering**

When equipped with tilt steering, the steering wheel can be tilted up or down so as to enhance the driver's comfort and enjoyment. To tilt the steering wheel, depress the release lever (adjusting tab) with your thumb to tilt the steering wheel. Be sure to hold the top of the wheel to assist in positioning. Release the lever once the steering wheel is in the position desired. See Figures G2 and G3. Refer to the steering manufacturer's literature, included in the owner's packet, for additional information.



**Figure G2: Adjusting Tab**



**Figure G3: Tilt Steering**

 **WARNING**

*The tilt mechanism should not be adjusted when the boat is moving. Sudden boat movement may cause loss of balance resulting in loss of control and/or injury.*

 **WARNING**

*The tilt mechanism is spring loaded. Due to the variation in steering wheel offerings, the wheel may spring up rapidly when depressing the release lever. Always keep one hand on the wheel during tilt adjustment to prevent possible damage to tilt mechanism and/or possible injury.*

## G - 2 STEERING LOAD

A load is placed on the steering system by the propeller torque, and/or water flowing past the rudder/outdrives. The steering system is designed to normalize the effort required to turn the steering wheel throughout the average operating speed range and general rudder/outdrive position. This is an advantage when the boat is on plane. This can be somewhat of a disadvantage at lower speeds in that the steering effort is not reduced to a level where it can be wheeled “lock to lock” without a concentrated turning effort.

 **CAUTION**

*Steering effort can vary significantly with engine acceleration, steering angle, trim angle, and sea condition. Be prepared for additional steering loads at all times.*

Models equipped with the Inboard Performance System (IPS) the propulsion forces and vibrations are absorbed by the combined rubber suspension and sealing. The propellers operate in undisturbed water with no cavitation. Also an increased number of propeller blades distribute the forces thereby reducing the effect of the pulses created by the propellers on the hull. All of this combined with the Electronic Vessel Control (EVC) system provides a smooth and exact steering with minimal to negligible steering load.

## G - 3 PROPELLER TORQUE

A boat with conventional drives, the propeller rotation of a single engine operation will exert a directional force on the steering system. This can cause the steering to be harder in one direction than the other, and is called propeller torque.

Propeller torque can also cause the boat to wander (not follow a straight line) when operated at low speeds. This condition is normal and can be corrected only by increasing engine rpm. Wind, water and currents can cause equivalent effects.

It should also be noted (per Volvo Penta®) on models equipped with Duoprop™ propellers that they improve low speed and reverse control/handling. The boat will steer straighter at cruising speed. Also the Duoprop™ propellers provide equal steering to both sides.

On V series with IPS, there are two counter-rotating propellers on each propulsion unit which means there are no lateral forces to consider and that tracking is completely straight. Propeller torque is negated.

## G - 4 STEERING SYSTEM MAINTENANCE

**NOTICE**

*Should adjustments and/or repairs be necessary, they should be performed only by a qualified service technician.*

A periodic inspection of all stern drive steering cables, linkage and helm assemblies should be made. Signs of corrosion, cracking, loosening of fastenings, excessive wear, or deterioration should be immediately corrected. Failure to do so could lead to steering system failure and corresponding loss of control.

The helm and cable assembly (if applicable) should be so adjusted that the steering wheel is centered with the drives in the straight ahead position. There should be an equal number of turns to port and starboard from the straight ahead position. If adjustment becomes necessary, see your Four Winns dealer.

All cables, helm assemblies, and steering connections should be periodically lubricated with a light, water-proof grease or as indicated in the manufacturers information provided in the owner's packet.



On V series models which have an advanced steering system such as EVC, **do not** change connectors, wiring or splice of the components.

Periodic inspections (every 200 hours/at least once a year) of the EVC system must be conducted. Service must be done by approved Volvo Penta® service centers which have certified personnel with qualified professional training. Contact your Four Winns dealer for assistance.



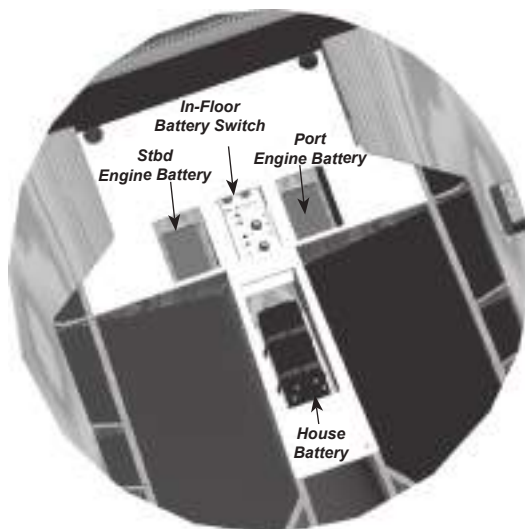
**H - 1 GENERAL**

All electrical equipment on the Four Winns V series domestic models operates on the following: 12 volts DC or 120 volts on 60 Hertz or 240 volts on 60 Hertz AC electrical power. Note: On domestic models supplied with the 240 volts AC, it is then split to two (2) - 120 volt AC circuits. On export model applications 230 volts on 50 Hertz models AC electrical power is typically used.

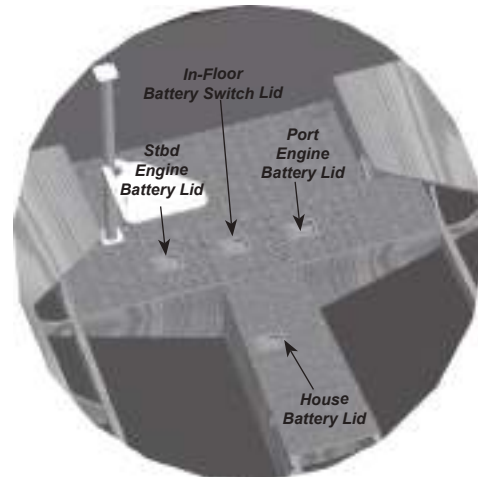
**NOTICE**

The V series electrical panels vary according to model and equipment availability. The labeling of switches and breakers may also vary. The information regarding general operation and activation is similar however. As with any equipment, be sure to read and understand the safe operating instructions provided by equipment manufacturer before using. If you are still experiencing difficulty please contact your Four Winns dealer or Four Winns for clarification

Depending on the model, the boat is equipped with either a dual or a triple battery system. If equipped with dockside power a battery charger is included. The batteries are located in the engine compartment. Certain models have a battery compartment(s) with lids inside the engine compartment/room. See Figures H1 & H2.



**Figure H1: Battery Locations - Engine Compartment**  
(Engine Compartment Layouts Vary by Model)



**Figure H2: Battery Locations - Engine Compartment**  
(Engine Compartment Layouts Vary by Model)


**Fire or Explosion Hazard!**

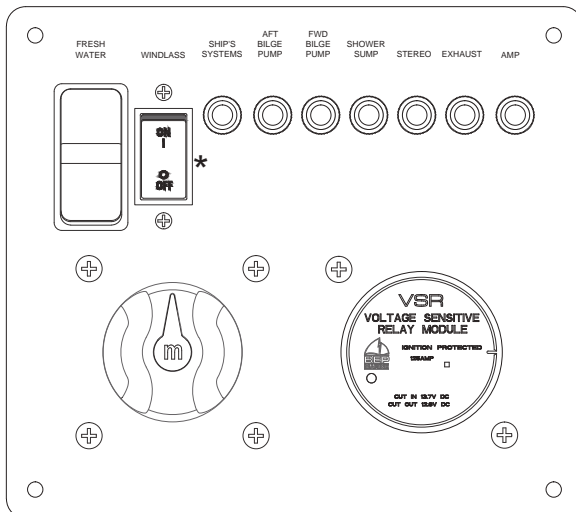
Electrical system parts are designed by and manufactured to comply with the US Coast Guard requirements to minimize risks of fire or explosion. **Never substitute automotive parts for marine parts.** Automotive parts do not provide the necessary ignition spark protection.



**DO NOT** tamper with any electrical connection, panel or harness, or attempt installation of any electrical equipment unless thoroughly familiar with the systems and experienced in making such installations.

**H - 2 SINGLE ENGINE - DUAL BATTERY SYSTEM**

If equipped with dual batteries and a battery switch, the boat has a designated battery for the ship's systems and for the engine. Circuit breakers are installed on the panel to protect various system component circuitry. The SHIP SYSTEMS breaker supplies power to all DC electrical components with the exceptions of aft and forward bilge pumps, shower sump, stereo memory, exhaust, and stereo amplifier. The circuit breakers and fuses are labeled for amperage and use. See Figure H3.



**Figure H3: Single Engine Battery Switch Panel**

#### NOTICE

Listed on the battery switch panel are various labels for the circuit breakers protecting different components. A particular label does not necessarily mean your boat is equipped with this component. The component may be either optional but not installed or not available for that particular model. Please contact your Four Winns dealer for should you have questions.

#### A. Installation

1. Connect each of the red (positive) battery cables leading from the battery selector switch to the positive (+) terminal on each of the two batteries.

#### NOTICE

Be sure the two red (positive) cables are installed on the positive (+) battery terminals.

2. Connect each of the black or yellow (negative) battery cables leading to the engine block to the negative (-) battery terminal on each of the two batteries.



When disconnecting the cables from the battery, make sure all switches are off and disconnect the black or yellow negative cable(s) first to prevent spark.

#### B. Battery Switch Operation

Power to the engine and all 12 volt electrical equipment is controlled at the battery switch panel. Separate circuit breakers are provided on the battery selector switch panel to protect the aft bilge and forward bilge pumps, shower sump, stereo memory, exhaust, and stereo amplifiers (if applicable). See Figure H3.

As described by the manufacturer, the battery switch (See Figure H4) makes it possible to switch two battery banks simultaneously with one single ON/OFF switch. It eliminates the confusion surrounding the traditional four-position selector battery switch. The battery switch offers simple ON/OFF switching and the isolated engine start and ship's systems (house) circuits reduces the chance of fully discharging both batteries. It also protects house electronics from engine starting sags and spikes as well as protecting engine electronics controls from stray house line noise.



**Figure H4: Battery Switch**

A description of the various positions for this battery switch is as follows:

“OFF” - With the battery selector switch in the “OFF” position, all 12 volt power to the boat is shut off completely except to the automatic bilge pump and stereo memory. A separate circuit breaker is provided on the battery switch panel for the automatic bilge pump. Always turn the battery selector switch to the “OFF” position when the boat is removed from the water.

**NOTICE**

*DO NOT turn or “pass” the battery selector switch to the “OFF” position while the engine is running. Alternator and wiring damage could result.*

“ON” (I) - When the battery switch is set to “ON”, current flows from the engine (start) battery to the engine start circuit, and from the ship’s systems (house) battery to the ship’s systems circuits.

“COMBINE BATTERIES” - When the battery switch is set to “COMBINE BATTERIES”, current flows from both ship’s systems and engine batteries to ship’s systems and engine circuits. The “COMBINE BATTERIES” function offers the ability to combine the two battery banks in the event of a low start battery. Once engine starts, return battery switch to “ON.”

**NOTICE**

*The panel is equipped with a voltage sensitive relay (VSR) to allow charging of all batteries when the alternator is charging.*

**H - 3 DUAL ENGINE - TRIPLE BATTERY SYSTEM**

Depending on the model, two or three battery selector switches are installed on dual engine, triple battery installations. This allows DC power to be used from any of the three batteries. On certain models the battery switch is located inside the systems locker or at the port transom.

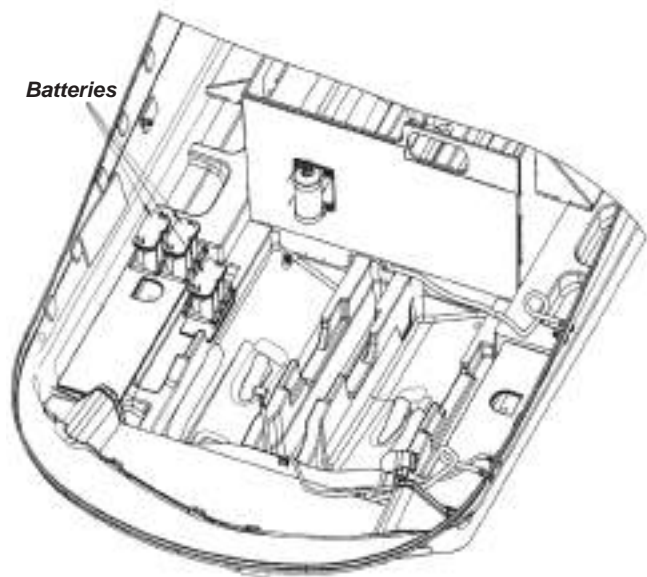
**A. Installation**

1. Connect each of the red (positive) battery cables leading from the battery selector switch to the positive (+) terminal on each of the three batteries. Refer to Figure H5.

**NOTICE**

*Be sure all three red (positive) cables are installed on the positive (+) battery terminals.*

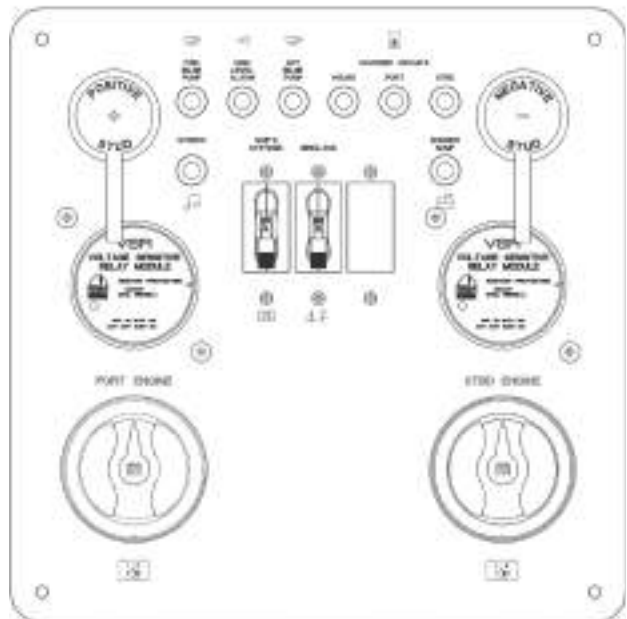
2. Connect each of the black or yellow (negative) battery cables leading to the engine block to the negative (-) battery terminals on each of the three batteries.



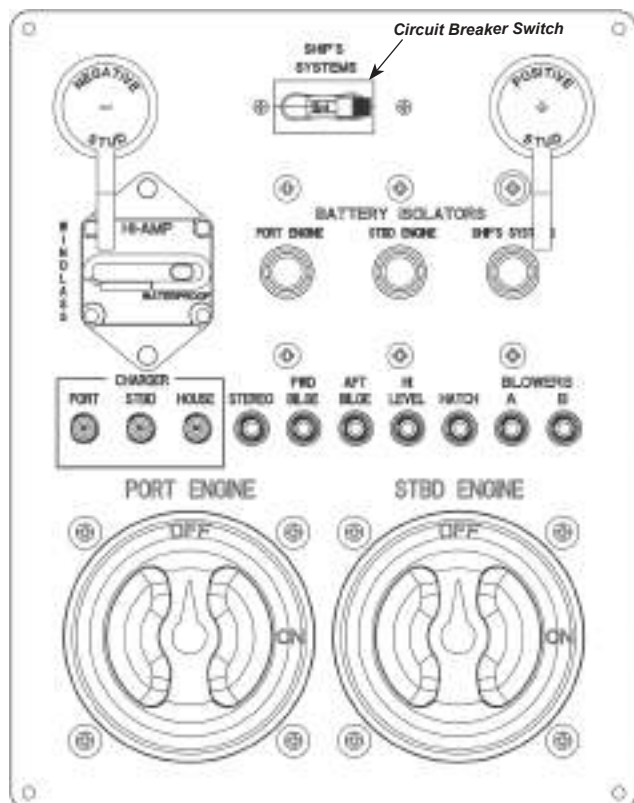
**Figure H5: Triple Battery System**  
(Location of Batteries May Vary by Model)

**B. Dual Switch Battery Panel**

Power to the engine and all 12 volt electrical equipment is controlled at the battery switch panel. Separate circuit breakers are provided on the battery selector switch panel to protect the circuitry to the aft bilge pump, forward bilge pump, shower sump, stereo memory, exhaust, hatch, ship’s systems and windlass (if applicable). See Figures H6 & H7 for some examples of battery switch panels.



**Figure H6: Dual Switch Battery Panel**  
(Certain Models Only)



**Figure H7: Dual Switch Battery Panel**  
(Certain Models Only)

On certain models the switches to activate the respective batteries and supply 12 volt power to related engine and/or ship's systems (HOUSE) equipment are located on the "Power Management Center" panel or "12VDC" cabin panel. See Figures H8 & H9. These types of switches are toggle switches. A LED light may be installed. If so, it will light up thus indicating that the switch is in the "ON" position.

### C. Battery Switch Operation

The battery selector switch positions for the dual switch battery panel, "Power Management Center" panel or 12VDC cabin panel are as follows:

"OFF" - With the battery selector switches in the "OFF" position and the "SHIPS SYSTEMS" circuit breaker in the "OFF" position (if applicable), all 12 volt power to the boat is shut off except to the fore and aft automatic bilge pumps, stereo memory, and ship's systems. Depending on the model the exhaust, hatch (electric lift) and windlass (if installed) may also have power even with the battery switches in the "OFF" position. Always turn the battery selector switches and the SHIPS SYSTEMS" circuit breaker switch (if applicable) to the "OFF" position when the boat is unattended for an extended period.

### NOTICE

Twelve volt power to the cabin panel is supplied by the "SHIPS SYSTEMS" circuit breaker switch on the battery selector panel. On models using this breaker switch, it must be turned on to operate any 12 volt accessories on the cabin panel. The bilge pumps, stereo and windlass receive power from the ships system battery and remain on at all time regardless of battery selector or ship systems switch position.

### NOTICE

DO NOT turn the battery selector switch to the "OFF" position while its corresponding engine is running. Alternator and wiring damage could result.

### Port Engine Battery Switch:

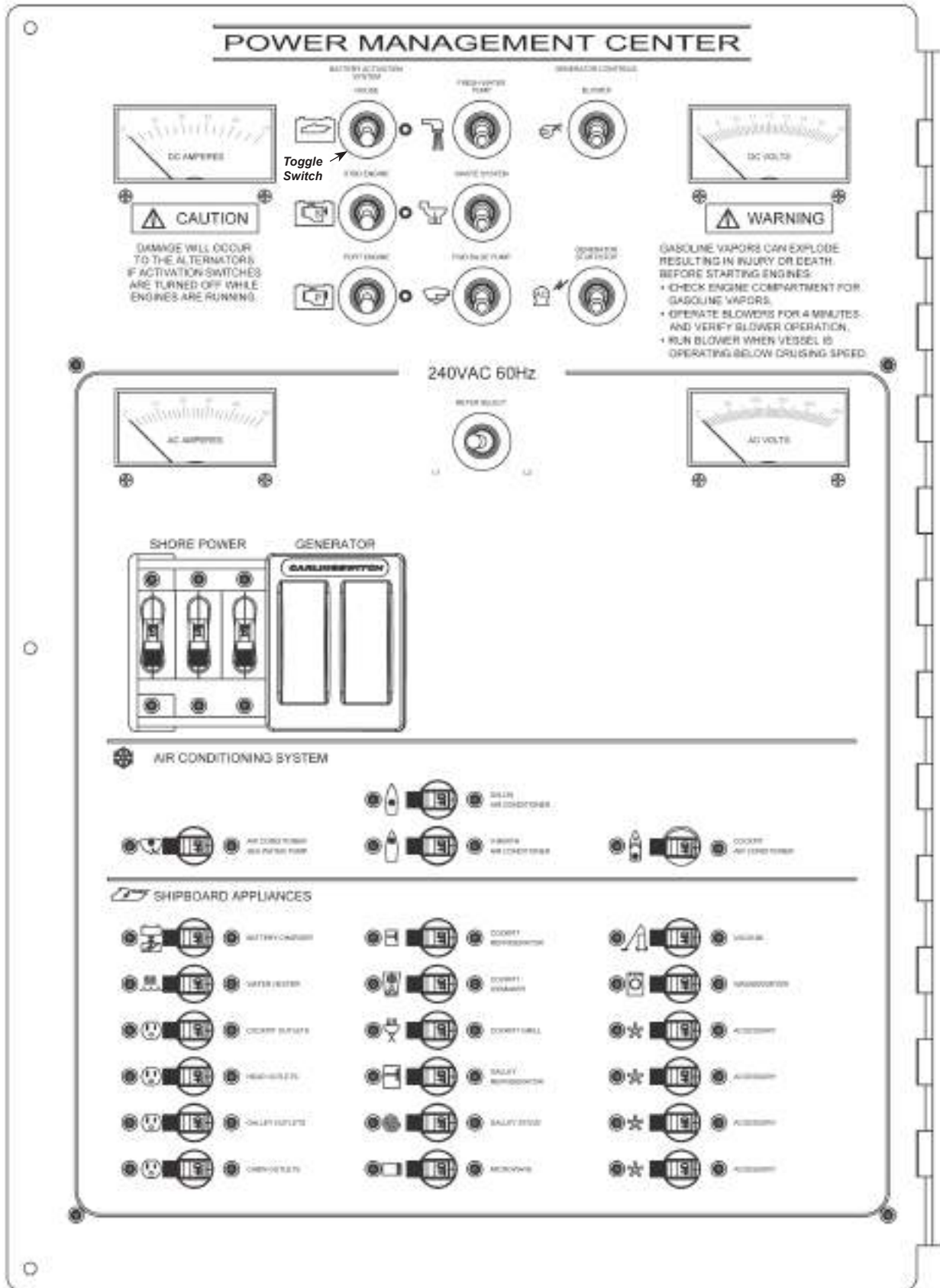
"ON" - Turning the switch to position "ON" will use the port engine battery to power the port engine and 12 volt engine related equipment. The ship's system battery will not be used for any engine related equipment. It will power all other 12 volt equipment on the boat when the associated switch (breaker or toggle) is placed in the "ON" position. The isolator will allow any alternator to charge all three batteries. "ON" is the recommended switch position for normal boat operation. This position allows maximum use of 12 volt equipment on the boat.

### Starboard Engine Battery Switch:

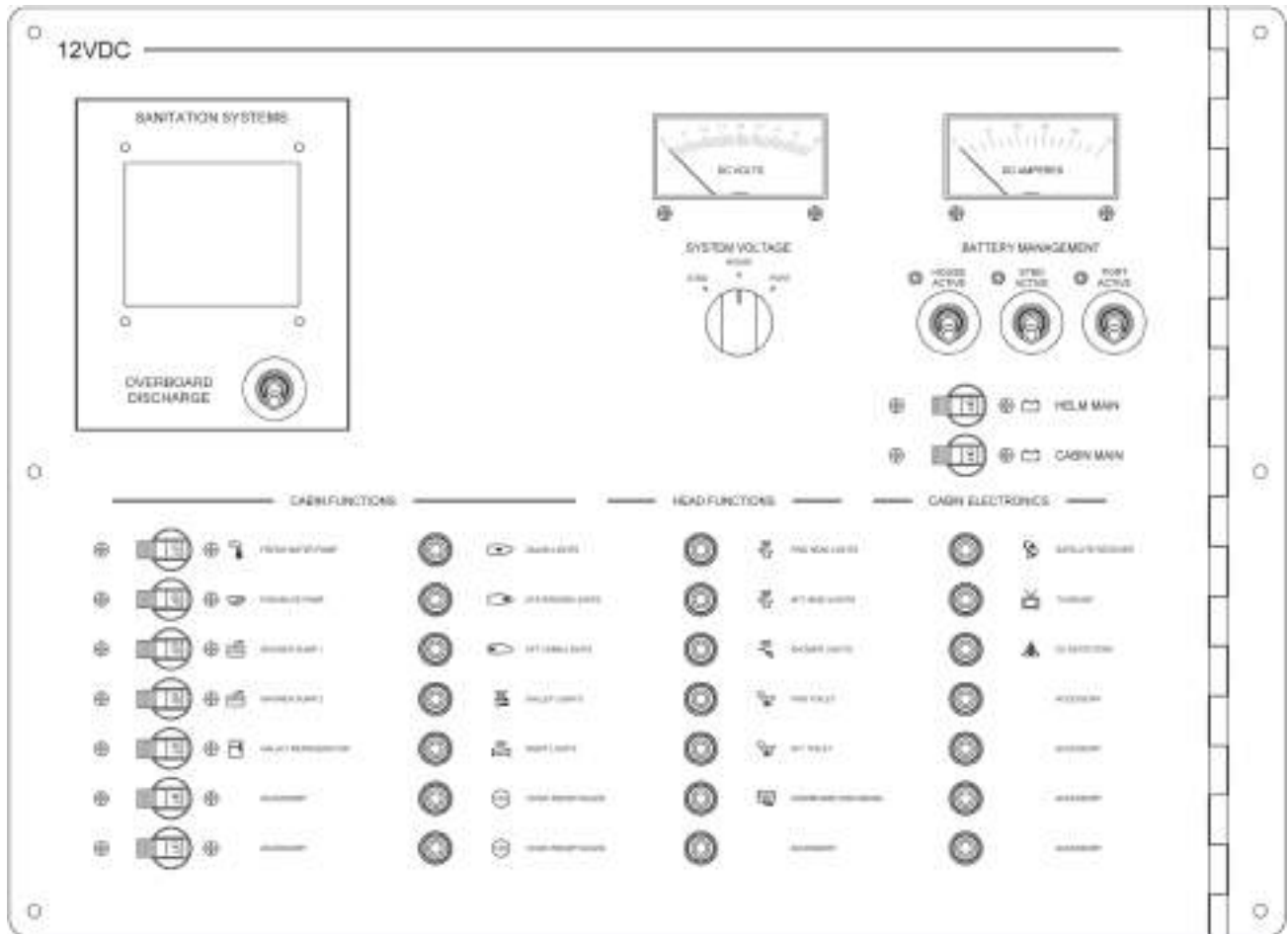
"ON" - Turning the switch to position "ON" will use the stbd engine battery to power the stbd engine and 12 volt engine related equipment. The ship's system battery will not be used for any engine related equipment. It will power all other 12 volt equipment on the boat when the associated switch (breaker or toggle) is placed in the "ON" position. The isolator will allow any alternator to charge all three batteries. "ON" is the recommended switch position for normal boat operation. This position allows maximum use of 12 volt equipment on the boat.

### Emergency Engine Start Procedures:

If one of the designated engine batteries fails to start its respective engine, turn the "EMERGENCY START" or "BATTERY PARALLEL" switch to "ON" at the helm and attempt to start the engine. Current is drawn from the other batteries to start the engine. Once engine has been started return the "EMERGENCY START" or "BATTERY



**Figure H8: Power Management Center**  
(Certain Models Only)



**Figure H9: 12VDC Cabin Panel**  
 (Representative View - 12VDC Panels & Equipment Availability Vary by Model)

PARALLEL” switch to the “OFF” position. Once back at port, be sure to have the failed engine battery checked for possible service or replacement.

**H - 4 CIRCUIT BREAKER PANELS**

The helm circuit breaker panel, main circuit breaker panel, aft circuit breaker panel and cabin electrical panels are placed in specific areas of the boat. Note: The numbers of circuit breaker panels as well as their location may vary by model. The circuit breakers are labeled on the panels which identify the component circuitry protected. These circuit breakers protect the designated circuitry from damage caused by an overload or short circuit. See Figures H10, H11 & H12 for some examples of circuit breaker panels.

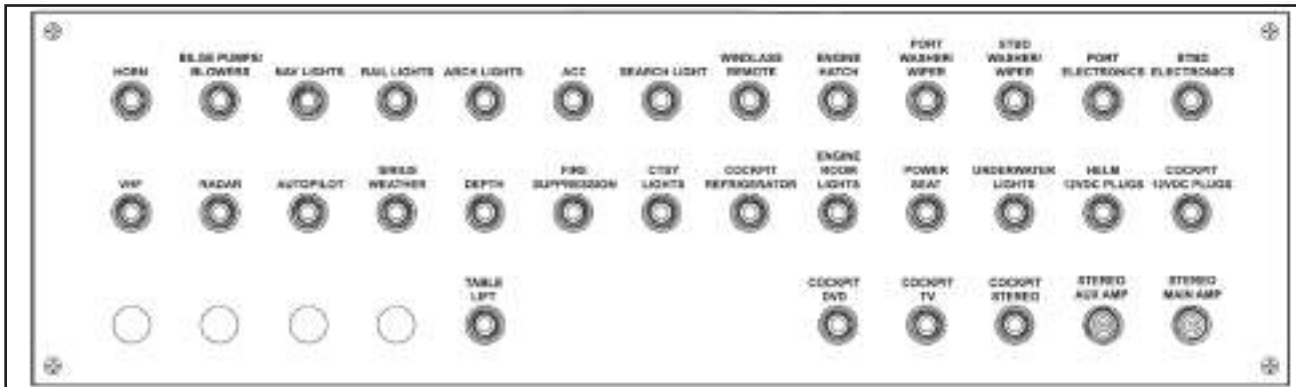


**Helm Circuit Breaker Panel**

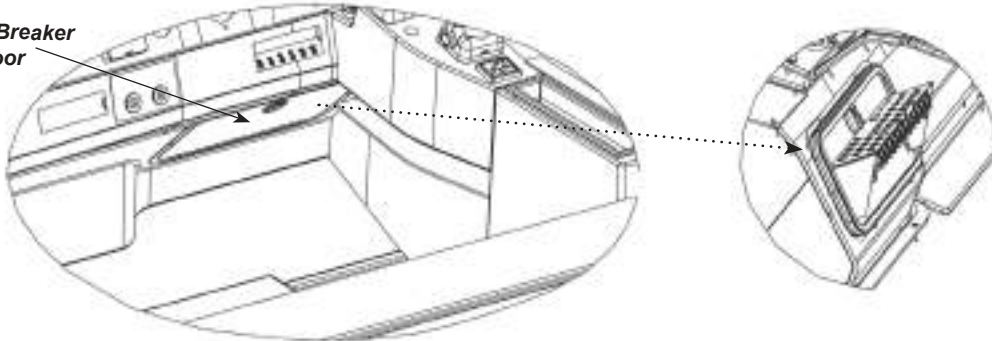


**Main Circuit Breaker Panel**

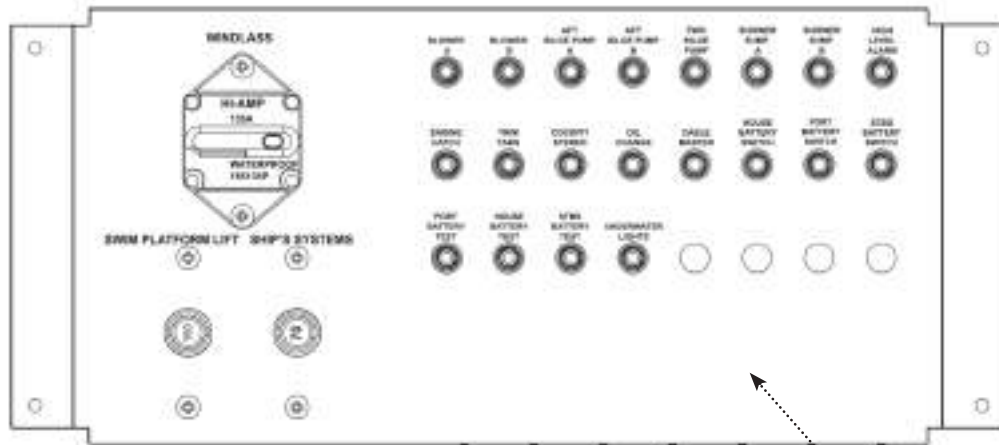
**Figure H10: Helm & Main Circuit Breaker Panel Location**  
 (Models Will Vary)



Helm Circuit Breaker Panel Door

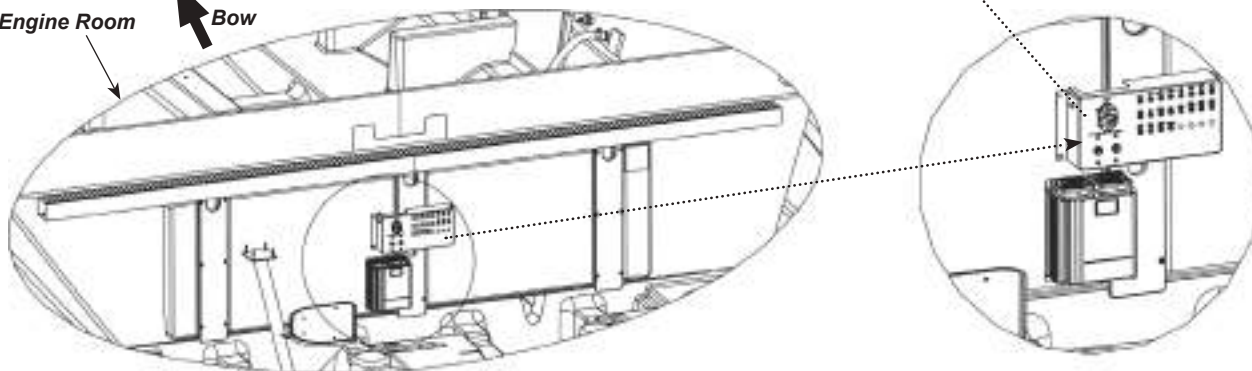


**Figure H11: Helm Circuit Breaker Panel**  
(Representative View - Panel & Equipment Availability May Vary by Model)



Engine Room

Bow



**Figure H12: Aft Circuit Breaker Panel and Location**  
(Certain Models Only)



### NOTICE

Listed on the battery switch panel are various labels for the circuit breakers protecting different components. A particular label does not necessarily mean your boat is equipped with this component. The component may be either optional but not installed or not available for that particular model. Please contact your Four Winns dealer for should you have questions.

If a circuit breaker does trip, determine the cause of the fault. Take the necessary steps to correct the cause. Once the correction has been made reset the circuit breaker.

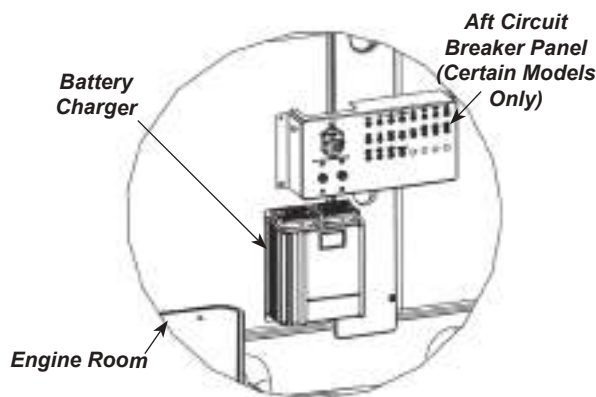


Do not keep resetting a circuit breaker without investigating the cause of the fault. Doing so could lead to damage to component circuitry or possible fire. Please see your authorized Four Winns dealer should problem persist.

Note: The engines and drive units are fitted with automatic circuit breakers. The circuit breakers cut the power should the system be overloaded. Please see engine operator's manual for specific information regarding your model.

## H - 5 BATTERY CHARGER

If equipped with dockside power a battery charger is included. The charger is typically located in engine compartment on most models. See Figure H13.



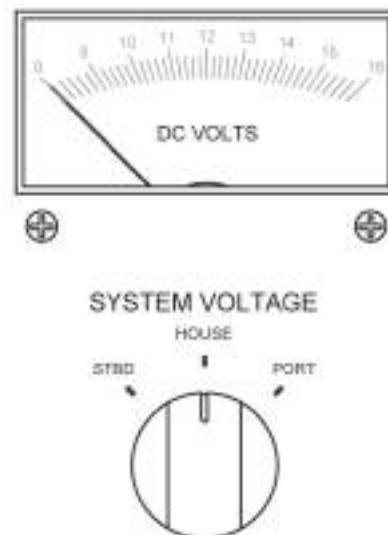
**Figure H13: Battery Charger - Representative View**  
(If Equipped - Location May Vary by Model)

The batteries will be charged by the battery charger when the boat is connected to dockside power and the SHORE circuit breakers and BATTERY CHARGER circuit breaker are "ON". These breakers are located on the AC cabin panel. See Figure H8. If a generator is available and operating, it too will allow the batteries to be charged by the battery charger when the BATTERY CHARGER circuit breaker is placed in the "ON" position.

Additional information on the battery charger can be found in Section H-10B - 120 Volt AC Equipment in this manual and refer to the manufacturer's literature included with the owner's packet.

## H - 6 12VDC VOLTMETER

Where a DC cabin panel is available, typically a voltmeter is installed. This voltmeter allows one to monitor the condition of the port engine, starboard engine or house battery. Place the selector switch to the desired battery to be checked and the voltage will be indicated on the voltmeter. See Figures H9 and H14.



**Figure H14: DC Cabin Panel - Voltmeter**  
(Representative View - Models May Vary)

It should be noted that the engine battery voltage may also be checked using the respective EVC display if applicable. Additional information on voltage may be found in the engine owner's manual.

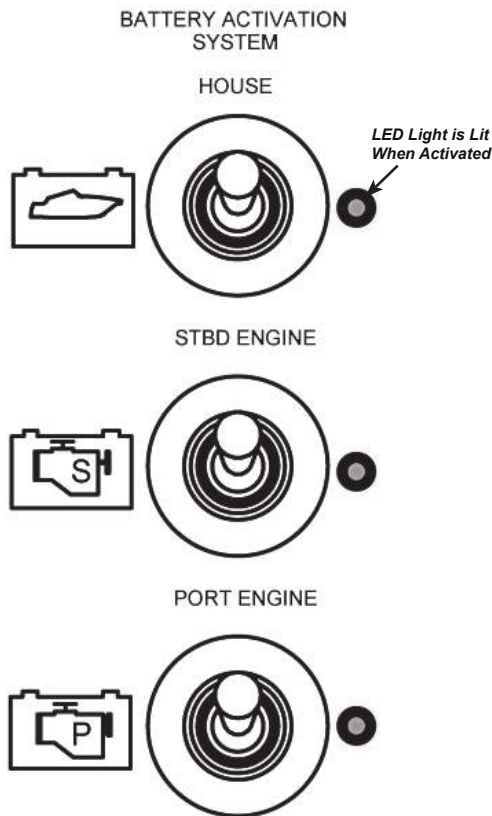
## H - 7 12 VOLT ELECTRICAL EQUIPMENT

### A. Helm Equipment

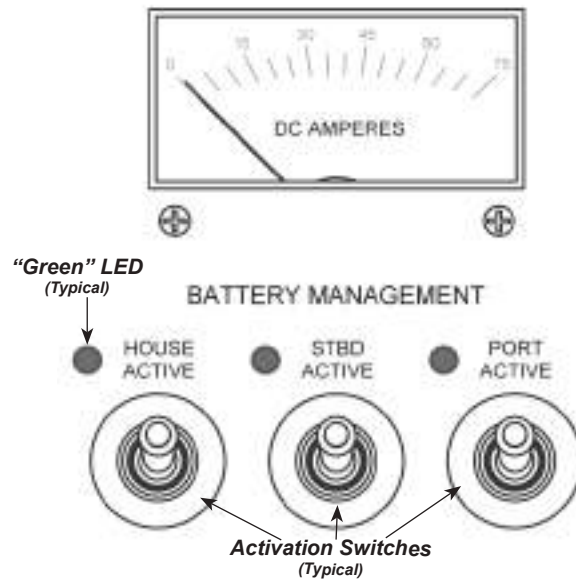
Helm equipment circuitry is typically protected by circuit breakers at the helm. Helm power is supplied on V series models with the “HOUSE” battery.

To supply power to the helm on certain V series models requires either turning the battery switch or the Ship’s Systems circuit breaker on the battery switch to the “ON” position. See Figures H3, H6 & H7.

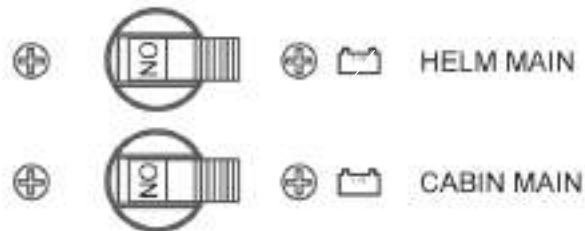
Other models require the following. If not already done, first place the “HOUSE” battery switch (at the battery switch) to the “ON” position. Secondly, there is a cabin panel either called a “Power Management Center” or a “12VDC” cabin panel. See Figures H15 & H16 respectively. Turn the “HOUSE” or the “HOUSE ACTIVE” switch to the “ON” position. Lastly if applicable, on the “12 VDC cabin panel” there is a “HELM MAIN” circuit breaker switch (Figure H17). Place this switch to the “ON” position as well. Power is then supplied to the helm. Note: Activation of the house battery is indicated by a lit LED light (depending on the model) Refer also to Figures H7-H9.



**Figure H15: Battery Activation System**  
(From Power Management Center)



**Figure H16: Battery Management (12VDC Cabin Panel)**  
(Representative View - Models May Vary)



**Figure H17 Helm & Cabin Main Circuit Breakers - “ON”**  
(12 VDC Cabin Panel - Representative View - Models May Vary)

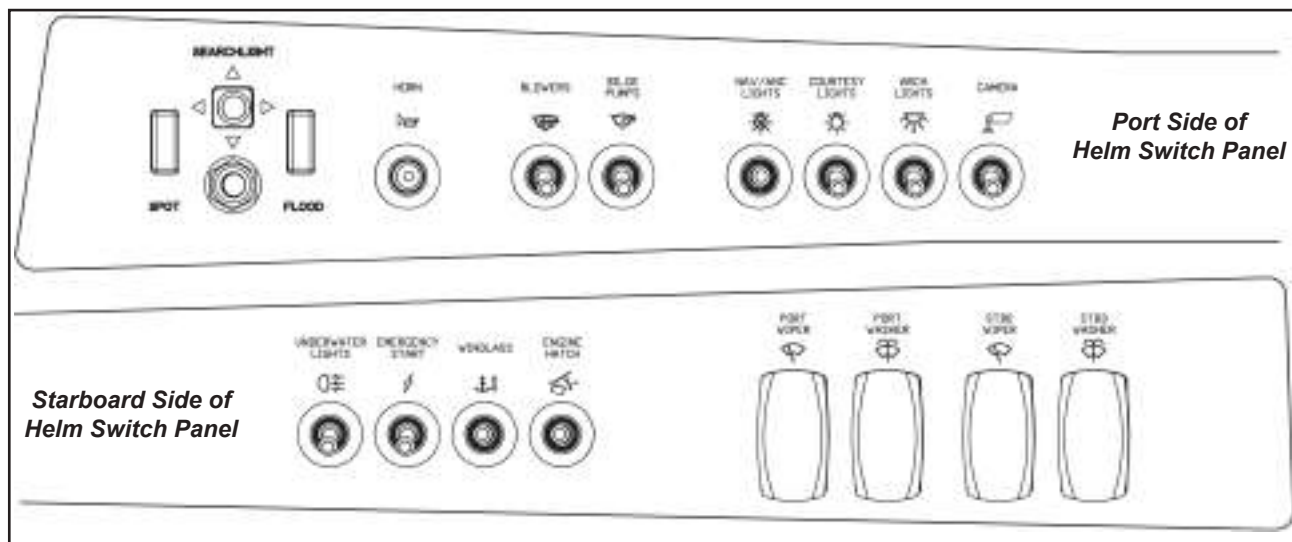
Helm switches are used to activate/deactivate various equipment. See Figure H18. Note: Equipment availability and description of switches may vary by model. To assist you, we have listed the descriptions of individual switches, receptacles and their uses:

**WARNING**

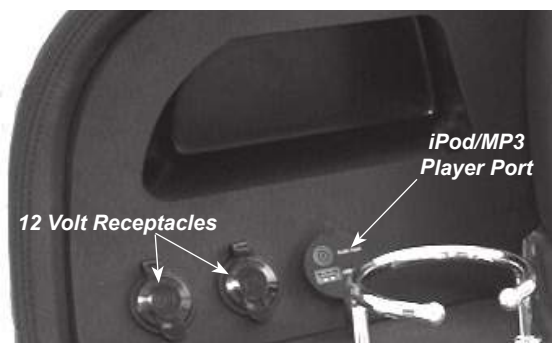
To avoid electrical problems, equipment damage or electrical fires, use only replacement fuses or breakers that are of equal rating to the originals.

12 Volt DC Receptacle - Permits the use of additional 12 volt equipment such as a cell phone. Using the appropriate adaptor, the equipment draws power from the boat’s house battery. See Figure F19.

iPod/MP3 Player Port - Allows you to play music from your iPod or MP3 player over your boat’s sound system. See Figure F19.



**Figure H18: Helm Switch Panel**  
(Representative View - Models May Vary)



**Figure H19: 12 Volt Receptacles & iPod/MP3 Player Port**  
(Representative View - Models May Vary)

**Searchlight Remote Control** - Allows the searchlight to be operated from the helm. Activate the switch to turn the searchlight "ON". Using the arrow button above the "ON" switch allows the searchlight to be positioned in the desired direction. The searchlight can be either a spot or flood light by pressing the respective switch. See Figure H20. Consult the manufacturer's operating manual for additional information on the use and care of the searchlight.



**Figure H20: Search Light Switches**  
(Representative View - Models May Vary)

**Horn** - To sound the horn, press the HORN switch.

**Blower** - The BLOWER switch is used to activate the bilge blower. Pressing the switch to the "ON" position, activates the electric bilge blowers, changing the air in the engine compartment that may contain fuel vapors.



**WARNING**  
Fuel vapors can explode resulting in injury or death. Before starting the engine, check engine compartment bilge for fuel or vapors. Operate blower for four minutes, and verify blower operation. ALWAYS run the blower when the vessel is operating below cruising speed.

**Aft Bilge Pump** - The BILGE PUMP switch is used to manually activate the bilge pump(s) in the engine compartment. The bilge pump(s) are used to remove water from the bilge (bottom of the hull) area of the boat by pumping this water overboard. The aft bilge pump(s) are equipped with an automatic bilge switch(es) and will operate whenever bilge water rises to a level that will cause the floats to move upward.

This automatic bilge pump(s) are active even if the battery activation switches on the DC cabin panel are in the "OFF" position. The automatic bilge pump circuitry is connected directly to the batteries. Circuit breakers are located at the helm circuit breaker panel and the aft circuit breaker panel (applicable models).

When leaving your boat unattended for an extended period, check the charge on the battery(s) periodically. Also check the water level in the bilge and make sure the float switch(es) are functional. If the automatic bilge pump(s) must be disabled, disconnect the wiring plug near the respective bilge pump.

**Navigation & Anchor Lights** - Moving the NAV/ANC LIGHTS switch to the NAV position (up position) activates the bow lights, the front portion of the mast light and the instrument lights on the dash. Move the switch to the ANC position (down position) to activate the all-around portion of the mast light. The center switch position is "OFF".

**Courtesy Lights** - The COURTESY LIGHTS switch is used to activate the courtesy (cockpit) lights. Additional courtesy light switches are located on the companionway light switch panel and on the transom switch panel. The switches may either be labeled COCKPIT LIGHTS or COURTESY LIGHTS. A key fob remote may also be available and used to activate the courtesy lights.

**Arch Lights** - The ARCH LIGHTS switch is used to activate the overhead lights on the hardtop. Another switch located on the transom switch labeled OVERHEAD LIGHTS will also activate these same lights.

**Accessories** - Additional 12 volt equipment may be added to the boat by the using the ACC switch on the port switch panel. Certain accessories may be wired directly to the helm circuit breaker. For additional information on adding accessories, refer to Section H-7B.

**Underwater Lighting** - If installed, the starboard ACC switch on the helm is used to operate this option should it be installed. To activate the underwater lighting place the starboard ACC switch to the ON position.

**Emergency Start** - If one of the designated engine batteries fails to start its respective engine, turn the "EMERGENCY START" or "BATTERY PARALLEL" switch to "ON" at the helm and attempt to start the engine. Current is drawn from the other batteries to start the engine. Once engine has been started return the "EMERGENCY START" or "BATTERY PARALLEL" switch to the "OFF" position. **Note:** Certain models have a momentary switch which combines the batteries for ten (10) minutes. Once back at port, be sure to have the failed engine battery checked for possible service or replacement.

**Windlass** - The WINDLASS switch activates the windlass. Circuit breakers are located on the helm and aft circuit breaker panels. Refer to the Section M-14 in this manual and the manufacturer's literature for additional information.

**Engine Hatch** - The ENGINE HATCH switch is used to raise and lower the engine hatch by activating a linear screw jack. Pressing the upper portion of the switch allows the engine hatch to be raised. Pressing the lower portion of switch lowers the engine hatch. On certain models, when the engine hatch is raised, the engine room lights are automatically turned on. When the engine hatch is closed the lights go off. The same is true should you access the engine room via the engine inspection hatch (if applicable).

**Port Wiper and Stbd Wipers** - If equipped, the PORT WIPER or STBD WIPER switch activates the port or starboard windshield wiper respectively. The wiper(s) will self park when switched OFF.

**Port Washer and Stbd Washer** (Certain V series models only). If equipped, the PORT WASHER or STBD WASHER switch activates the port or starboard windshield washer respectively.

## B. Installation of Additional 12 Volt Equipment

Accessories may be added to the boat by wiring directly to the cabin panel. Non-factory installed 12 volt accessory equipment can be connected to the port ACC switch on the dash.



*Be sure to provide proper fuse or circuit breaker protection for all 12 volt equipment that is installed. DO NOT overload the accessory circuitry by installing too much additional 12 volt equipment.*



*DO NOT attempt installation of additional 12 volt equipment unless you are familiar with the proper electrical procedures involved. Failure to properly install equipment could lead to equipment damage and/or possible fire.*

## C. Interior/Exterior Equipment

### NOTICE

*The V series 12VDC electrical panels, such as light and cabin panels, vary according to model and equipment availability. The information regarding general activation of the 12VDC equipment is however similar. If you are still experiencing difficulty after reading this section, please contact your Four Winns dealer for assistance.*

To supply power to the cabin equipment on certain models requires either turning the battery switch or the Ship's Systems circuit breaker on the battery switch to the "ON" position. See Figures H3, H6 & H7.

Other models require the following. If not already done, first place the "HOUSE" battery switch (at the battery switch) to the "ON" position. Secondly, (depending on the model) there is a cabin panel either called "Power Management Center" or the "12VDC" cabin panel. See Figures H15 & H16 respectively. Turn the "HOUSE" or the "HOUSE ACTIVE" switch to the "ON" position. Lastly if applicable, on the "12 VDC" cabin panel there is a "CABIN MAIN" circuit breaker switch (Figure H17). Place this switch to the "ON" position as well. Power is then supplied to the cabin. Note: Activation of the house battery is indicated by a lit LED light (depending on the model) Refer also to Figures H7-H9.

The following is a listing followed by a brief description of the certain 12 volt cabin equipment. The equipment's circuitry is protected by circuit breakers on cabin 12VDC panel (if applicable). Additionally, certain 12 volt equipment may have an additional circuit breaker located on another circuit breaker panel.

**Note:** When applicable the specific circuit breaker on the cabin panel must also be activated (placed in the "ON" position) in order for the desired equipment to work.

**Step Lights** - If installed the STEP LTS switch (located on the transom switch) is used to activate the step lights at the transom and for the deck lighting in the rail.

**Transom Speakers** - If installed this switch is part of the transom switch assembly. The switch permits one to conveniently turn the transom speakers "ON" or "OFF" while at the transom.

**Engine Room Lights** - If equipped these lights are activated automatically when either the engine hatch or the engine inspection hatch are raised.

**Fresh Water Pump** - A pressure water pump delivers water to the faucets, shower, and transom washdown (if installed) The pressure water pump will operate automatically as long as the FRESH WATER PUMP circuit breaker switch is "ON". Turn the FRESH WATER PUMP circuit breaker switch "OFF" when the water tank becomes empty or when water will not be required for an extended period or when connected to shore water while at dockside. Tank monitoring systems are available to check water levels. Refer to Sections J-1 and J-4 in this manual for additional information.

**Forward Bilge Pump** - The forward bilge pump can be activated manually by the FWD BILGE PUMP breaker switch placed in the "ON" position. Any water from the stringers or from other sources within the cabin will drain into the forward bilge compartment. The pump is equipped with an automatic float switch and will operate whenever bilge water rises to a level that will cause the float to move upward. The water will be pumped overboard.

**Shower Sump Pump(s)** - These shower sump pump(s) are used to discharge water from their respective shower and sink sump(s) overboard or into an available gray water tank (if installed). These sump pumps have a float switch which will activate the pump when the water level rises in the sump. The respective pump is protected by the SHOWER SUMP PUMP circuit breaker(s).

**Galley Refrigerator/Freezer** - If equipped, this refrigerator/freezer is a dual voltage unit and therefore has a circuit breaker provided on both the AC cabin panel and on the 12VDC cabin panel (if available) to provide protection no matter which power source is being used. The refrigerator/freezer typically has a separate "ON/OFF" switch also. Refer to Section L-1C in this manual and to the manufacturer's literature for additional information.

**Accessories** - Additional 12 volt equipment may be added to the boat by wiring directly to the cabin panel using the existing ACCESSORY circuit breaker(s) provided. See Section H-7B -- Installation of Additional 12 Volt Equipment.

**Salon Lights/Stateroom Lights/Aft Cabin Lights/Galley Lights/Night Lights/Fwd Head Lights/Aft Head Lights/**

Shower Lights - The light's circuitry is protected by its respective circuit breaker at the panel. With the CABIN MAIN circuit breaker "ON", these various lights may be activated using the corresponding ON/OFF switch (if applicable). The switches on these panel assemblies are labeled to indicate which switch activates what on that particular light panel assembly. A variety of switch panels assemblies may be located throughout the boat. Additionally, duplicate ON/OFF light switches may be located in various areas of the cabin i.e. forward berthing area for convenience.

12 Volt Receptacles - These receptacles can be utilized when the respective 12VDC PLUGS circuit breaker is in the "ON" position.

Forward Toilet and/or Aft Toilet - These toilets (if applicable) utilize an electronic switch for flushing and therefore power must be supplied and circuitry protected through their respective circuit breaker labeled either FWD TOILET or AFT TOILET.

Overboard Discharge - If installed, the waste from the waste holding tank may be pumped overboard when the OVERBOARD DISCHARGE circuit breaker is "ON" and the OVERBOARD DISCHARGE SWITCH is depressed. See Figure H21.

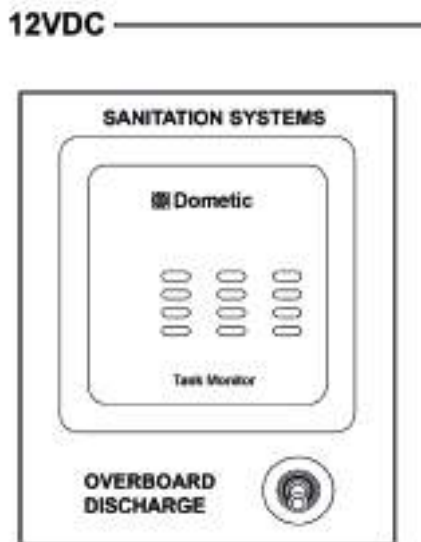


Figure H21: Overboard Discharge Switch

**Note:** The seacock for overboard discharge must first be opened before depressing switch. See Section J - Water and Waste Systems of this manual for further details and regulations regarding the discharging of waste overboard.

Satellite Receivers - If equipped, the satellite receiver's circuitry is protected through its respective circuit breaker. In order for the satellite receiver to function the CABIN MAIN circuit breaker must be "ON".

CO Monitor (Detector) - The CO monitors' wiring is protected by the circuit breaker in the cabin panel labeled CO DETECTORS.

TV Mount - The TV mount (if applicable) in the galley is operated through an electrical control and therefore has a circuit breaker labeled TV MOUNT. The switch that controls the TV mount is located in the galley, near the TV, and is called the Forward Galley Salon switch panel.

## H - 8 12 VOLT ELECTRICAL SYSTEM SHUTDOWN PROCEDURES

When leaving your boat unattended for an extended period of time it is advisable to shutdown the electrical system to reduce battery drainage and/or possible electrical draw.

### To shutdown:

1. On the 12VDC cabin panel, turn the HELM MAIN and CABIN MAIN circuit breaker switches (applicable models) to the "OFF" position. See Figure H22. Switch the HOUSE ACTIVE, STBD ACTIVE and PORT ACTIVE switches to the "OFF" position. See Figure H23.

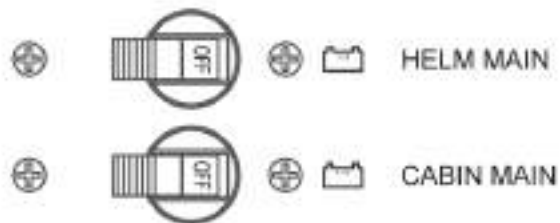
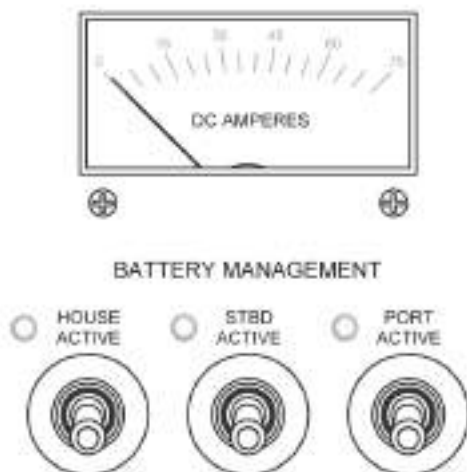


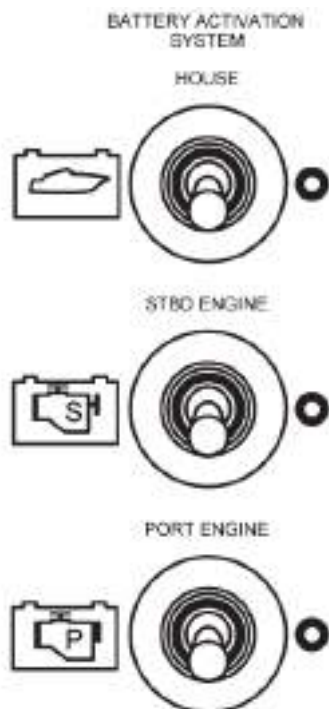
Figure H22: Helm & Cabin Main Circuit Breakers - "OFF"

## H - 9 120 & 240/120 VOLT ELECTRICAL SYSTEMS



**Figure H23: Battery Activation Switches - "OFF"**

- 1b. On models with a Power Management Center, switch the HOUSE, STBD ENGINE and PORT ENGINE switches to the "OFF" position. See Figure H24.



**Figure H24: Battery Activation Switches - "OFF"**

2. Depending on the model, turn the windlass switch (if applicable), the Ship's Systems switch (if applicable) and all battery switch(es) on the battery switch panel to the "OFF" position. See Figures H3, H6 & H7.

### NOTICE

The V series AC electrical panels vary according to model and equipment availability. The labeling of switches and breakers may also vary. The information regarding general operation and activation is similar however. As with any equipment, be sure to read and understand the safe operating instructions provided by equipment manufacturer before using. If you are still experiencing difficulty please contact your Four Winns dealer or Four Winns for clarification

When the boat is connected to a shore power outlet and the respective circuit breaker(s) is ON, the AC system supplies 120 volt 60 Hertz (230 volt 50Hz - export) electrical power to the following items such as the cockpit refrigerator, icemaker, grill, battery charger, water heater, cockpit TV, galley refrigerator, washer/dryer, range, microwave, vacuum, and/or various outlets. Refer to the AC cabin panels, Figures H38-H41, which have been placed at the end of this section to assist you.

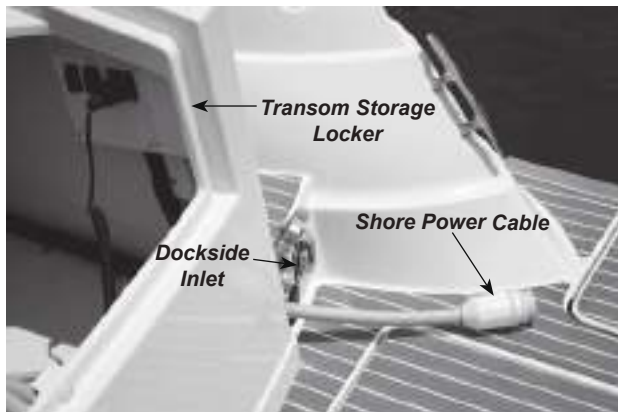
### NOTICE

Listed on 120VAC 60HZ & 240VAC 60Hz cabin electrical panels are various labels for the circuit breakers protecting different component circuitry. A particular label does not necessarily mean your boat is equipped with this component if the component is optional. Please contact your Four Winns dealer if you have questions.

The dockside system uses four-wire, color-coded circuitry. The black and red or hot wires are the ungrounded current carrying conductors. The white or neutral wire is the grounded current carrying conductor. The green wire, referred to as the "equipment ground," is a grounded conductor, and under normal conditions is not a current carrying wire. The neutral wires are connected together at a buss bar. The equipment grounds are similarly connected together at another buss bar. Each hot wire is connected to, and protected by, a circuit breaker in the distribution box located at the top section of the AC cabin panel identified as either "120VAC 60 Hz or "240VAC 60Hz". See Figures H38 - H41 at the end of this section.

The dockside system installed has a main circuit breaker which protects the overall distribution network. Depending on the V series models, it may have the MAIN dockside inlets located either on the port or starboard deck or in the aft transom systems locker.

Certain V series models have a MAIN dockside inlet with Cablemaster shore power cable storage system located at the starboard side of the aft transom. The switch which extends or retracts the Cablemaster shore power cable is typically located inside the transom storage locker. See Figures H25 & H26.



**Figure H25: Dockside Inlet Location**

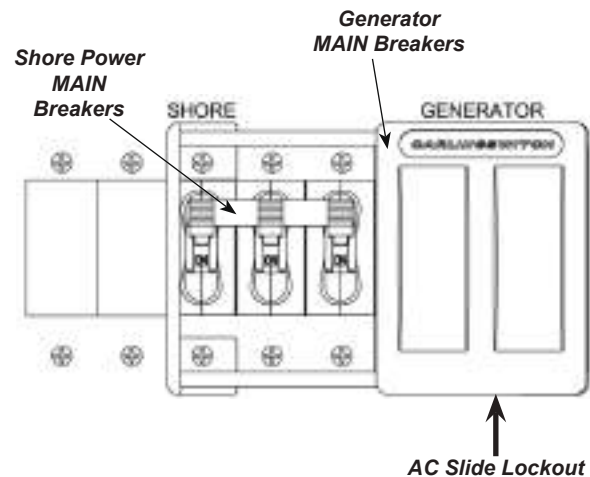


**Figure H26: Cablemaster Switch Location**

The MAIN circuit breakers on the AC/DC cabin panel. The MAIN breakers must be turned "ON" and the boat must be connected either to shore power or generator running for AC system operation. The MAIN circuit breaker protects both the hot and neutral input leads. This breaker is sensitive. The resulting power surge which occurs when connecting the shore power cord

may cause the MAIN breakers to trip. To avoid this power spike, turn off the MAIN breakers before plugging in the shore power cord. Securely connect the power inlet of the boat and the shore power receptacle. Once the shore power is securely connected, turn the MAIN breakers back on. If the connection is broken and later re-secured, the circuit breaker may trip. Connections must be secure for uninterrupted dockside service.

Certain V series models have main circuit breakers on the AC panel labeled SHORE and GENERATOR. See Figure H27.



**Figure H27: AC Cabin Panel - Main Breakers  
(Panels May Vary)**

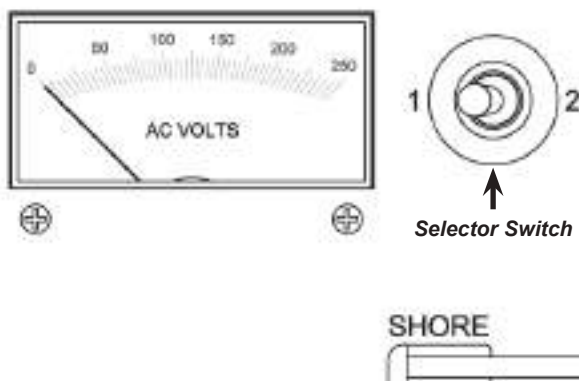
The respective main breakers must be turned ON and the boat must either be connected to shore power or the generator must be running for AC system operation. **Note:** An AC slide lockout is installed on the MAIN breaker switches to prevent energizing both the SHORE and GENERATOR systems simultaneously thus preventing possible damage to the electrical system.



**Never** override the AC slide lockout mechanism. Damage to the electrical system and possible fire and/or death could result.

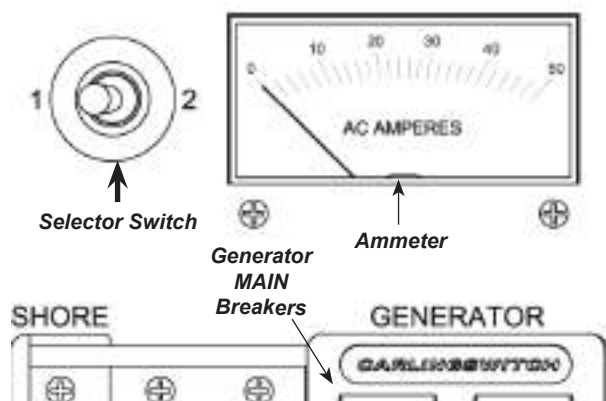
The AC voltage for the shore power AC or generator systems may be monitored with the voltmeter in the AC panel. The SHORE or GENERATOR voltage is automatically monitored when that particular system is activated/energized. See Figure H28.





**Figure H28: AC Volt Meter**  
(Panels May Vary)

Also on the AC main distribution panel is an ammeter and on certain models an ammeter selector switch. See Figure H29.



**Figure H29: Ammeter & Selector Switch**  
(Panels May Vary)

The ammeter measures the amount of current, in amperes, flowing through the selected circuit. Place the selector switch to the desired meter to be monitored (if applicable). When 120 volt equipment is turned ON and the ammeter is selected. It should indicate a certain amount of current flow for the circuit. This in turn tells you that your 120VAC equipment is working. **Note:** Should you notice the SHORE (Main) circuit breakers constantly tripping; this is an indication of a problem with one of the 120 or 240 volt electrical circuits. Have the 120 volt circuit and 240 volt circuit (if applicable) checked by a qualified marine electrician.

Most receptacle circuits are capable of handling 15 amperes. Refer to Table I for a list of equipment and the electrical currents usually required to operate these items. For 230 volt, 50 Hertz models, divide all of the current ratings by 2. Usually, the power require-

ment is specified on the electrical item. This is only an approximation of the electric current usage normally experienced.

EQUIPMENT	ELECTRICAL LOADS
Air Conditioners	See motor load plate
Battery Chargers	Up to 800 watts (7.3 amps)
Blankets (Electric)	50 to 200 watts (2 amps)
Coffee Makers	550 to 700 watts (6.3 amps)
Electrical Drills	See motor load plate
Fans	25 to 75 watts (0.7 amps)
Fry Pan	1350 watts (12.3 amps)
Heater	1500 watts (13.7 amps)
Lights	Wattage as marked
Television	1500 watts (10.5 amps)
Vacuum Cleaners	See motor load plate

**Table I: Electrical Equipment**

## H - 10 DOCKSIDE OPERATION

### WARNING

*If any abnormalities appear during dockside operation, DISCONNECT the system immediately to prevent electric shock hazards! Have the boat's electrical system and the shoreside receptacles checked as soon as possible.*

### A. Shore Power Connections

### WARNING

*To prevent electric shock hazards, use only equipment with approved three wire electrical plug connections. Be sure each item being used has been tested and is free of electrical shorts and ground faults.*

Shore power inlets (if equipped) are installed either on port or starboard deck or ship's systems locker depending on the model. Certain V series comes equipped with a Cablemaster shore power cable storage system. This system allows one to pay out or retract the dockside power cable automatically. The system comes with a seventy-five foot, 50 amp, three-wire shore power cable. **Note:** The amount of usable dockside cable is approximately fifty feet due to 25 feet being used inside the boat for connection purposes. The dockside cable(s) have a "twist lock-type" connector. This type connector complies with the

American Boat and Yacht Council (ABYC) standards. See Figures H25 and H26.

To extend the Cablemaster shore power cable (if equipped):

- 1) Flip the power switch to “OUT” position; grasp the power cord plug.
- 2) Walk to dock power source and plug power cord into receptacle.
- 3) Cablemaster will automatically shut itself “OFF” when cable has fully extended or when the momentary switch is released.
- 4) If less cable is more desirable, turn switch to the “IN” position.
- 5) Release switch when desired cable length is achieved

To retract the Cablemaster shore power cable:

- 1) Disconnect the power cord plug from the dock power source.
- 2) While holding power plug, walk to Cablemaster.
- 3) Turn the power switch to the “IN” position.
- 4) Cablemaster will automatically shut itself off when cable has fully retracted or when the momentary switch is released. **Do not move vessel until cable is fully retracted!**

Some marinas are not equipped with approved twist lock-type receptacles. Use only an adaptor approved by the manufacturer when an adaptor is necessary. An adaptor may be available through the dockside cable manufacturer, Marinco®. Follow the manufacturer’s instructions regarding its use.



**DO NOT** use a two-wire adaptor to connect to a three-wire system. These adaptors do not provide adequate grounding.

Shore power connection procedure is as follows:

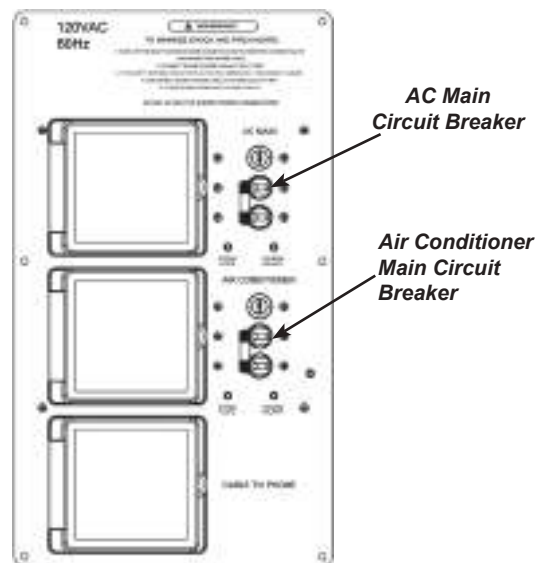
1. Be sure the generator is “OFF” (if equipped). Place the AC lockout slider over the GENERATOR main circuit breakers on the AC panel.

2. Turn “OFF” the boat’s main (SHORE) breaker switch before connecting or disconnecting the shore power cable.
3. Connect shore power cable to the dockside inlet receptacle of the boat first, then connect it to dockside shore power outlet. Omit this step if equipped with Cablemaster.

#### NOTICE

*Always connect the cord to the shore power inlet receptacle of the boat before making connections to the shore power source. Not applicable for Cablemaster equipped models.*

4. Connect shore power cable to dockside shore power outlet. If equipped with Cablemaster following procedure described earlier regarding extended the shore power cable.
5. Check for reversed polarity on the AC panel. If the reversed polarity light is activated, immediately disconnect the shore power cord. See Section H-10C - Reverse Polarity Indicator.
6. Turn the SHORE main breakers at the AC cabin panel and at the dockside outlet (if applicable) to the “ON” position. See Figure H30.



**Figure H30: Shore Power Inlet**  
(Representative View - Models May Vary)

To disconnect shore power:

1. Turn the main (SHORE) circuit breaker switches to the “OFF” position located on the AC panel and at the dockside inlet of the boat (certain models only). See Figure H30.

2. Disconnect the shore power cable from the shore power dockside receptacle. Retract the shore power cable following the procedure described earlier if the boat is equipped with Cablemaster.

**NOTICE**

*Always disconnect the shore power cord from the dockside first before disconnecting from the boat. Not applicable for Cablemaster equipped models.*



*Always remember to disconnect and properly store the shore power cable first before leaving the dock. Retract the shore power cable if applicable. Failure to do so may lead to the damage of the shore power cable, electrical system and/or boat.*

**B. 120 Volt AC Equipment****NOTICE**

*Listed on 120VAC 60HZ & 240VAC 60Hz cabin electrical panels are various labels for the circuit breakers protecting different component circuitry. A particular label does not necessarily mean your boat is equipped with this component if the component is optional. Please see your Four Winns dealer for details.*

All 12 volt equipment is isolated from the 120 VAC 60Hz and the 240/120VAC 60Hz systems with the exception of the cockpit and galley refrigerators which are dual voltage. When AC power is supplied by either dockside power or by the generator and with the respective main circuit breakers ON, the individual circuit breakers on the panel provide protection for that specific equipment's circuitry (if installed). The receptacles can be used for 120 volt (230 volts on 50 Hertz - export) household appliances. Refer to the following list for information on appliances and other equipment.

**NOTICE**

*As with any equipment, be sure to read and understand the safe operating instructions provided by equipment manufacturer before using. This information is included in your owner's packet.*

**Cockpit Refrigerator** - If equipped, the cockpit refrigerator is a dual voltage appliance. The COCKPIT REFRIGERATOR breaker located on the 120VAC cabin panel must be ON to supply 120 volt power to the refrigerator. If this breaker is off, the refrigerator will automatically operate on the 12 volt system

**Cockpit Ice maker** - The cockpit icemaker is available on certain V series models. If equipped, the ICEMAKER breaker is located on the applicable cabin panel must be ON to supply 120 volt power to the icemaker. Note: The icemaker may be exchanged for a refrigerator on certain models. If so the icebreaker would use the refrigerator's circuit breaker

**Electric Grill** - If equipped, allows grilling at the transom/cockpit. The grill may be operated once the GRILL breaker is placed in the ON position. Also a ground fault circuit interrupter (GFCI) is located underneath the grill.

**Battery Charger** - The battery charger is controlled by a circuit breaker on the AC electrical panel in the cabin labeled BATTERY CHARGER. In order for the charger to charge the batteries the circuit breaker must be ON while connected to dockside power. If a generator is available and operating it too will allow the batteries to be charged by the battery charger when the circuit breaker is ON.

**Water Heater** - The WATER HEATER circuit breaker supplies power to the water heater. Refer to Section J-3C - Water Heating Systems in this manual for more information.

**NOTICE**

*DO NOT supply electrical power to an empty water heater. Activate the FRESH WATER PUMP circuit breaker on the 12VDC panel to energize the water pump and prime the system when **not** connected to dockside water. Be sure there is adequate water in the system before turning on the water heater. Failure to comply will result in immediate damage to the heater element.*

**Cockpit TV** - This circuit breaker when switched ON provides power the cockpit TV if so equipped. Note: Certain models may have an electrical lift at the cockpit refreshment center for the TV while other have a TV mount in the cockpit..

Galley Refrigerator/Freezer - The GALLEY REFRIGERATOR circuit breaker must be ON to operate on 120 voltage. If this breaker is OFF, the refrigerator/freezer will automatically operate on the 12 volt system. This can deplete the battery. Excessive drain on the battery may cause irreparable battery damage. The refrigerator/freezer will automatically operate on 120 volts when provided. Refer to Section L-1C - Galley Equipment in this manual for more information.

Electric Stove - The RANGE circuit breaker must be activated to supply power to the electric stove. Refer to Section L-1 - Galley Equipment in this manual for more information.

Microwave - The MICROWAVE breaker must be energized to supply power to the microwave.

Washer/Dryer (Optional) - Power is supplied to the washer/dryer when the WASHER/DRYER circuit breaker is placed in the ON position.

Vacuum - The VACUUM circuit breaker must be activated to supply power to the vacuum.

Forward Battery Charger - Not applicable to the V475 with the Inboard Performance System (IPS) installed.

Receptacles - The OUTLETS circuit breakers supply power to the corresponding receptacles in the AC system.

Accessories - Additional 120 volt (220 volts on 60 Hertz) equipment may be added to the boat by wiring directly to the 120VAC 60Hz or 240V 60Hz cabin panel using the existing ACCESSORY circuit breakers provided. See Section H-7B - Installation of Additional 12 Volt Equipment.

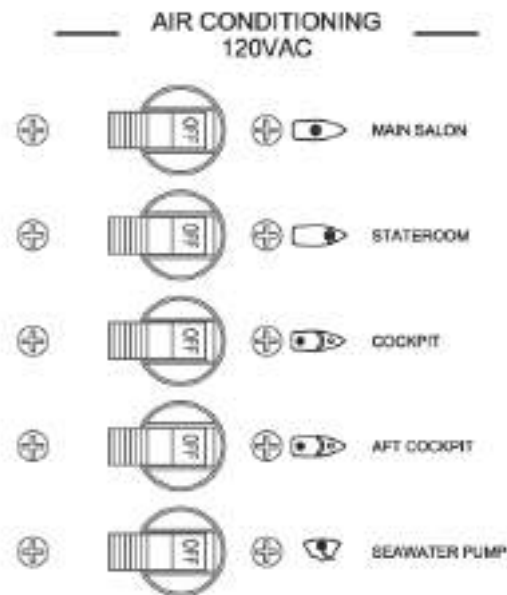
**⚠ WARNING**

*DO NOT attempt installation of additional 120 volt (230 volts) equipment unless you are familiar with the proper electrical procedures involved. Failure to properly install equipment could lead to equipment damage and/or possible fire. Due to the complex nature of the electrical system Four Winns recommends that installation of any additional 120 volt (230 volt) equipment be conducted by a qualified marine electrician.*

Air Conditioner - On domestic models the air conditioner(s) run on 120 volt AC system (if equipped). The AIR CONDITIONER circuit breakers supply power to the air

conditioner(s) and seawater pump (if equipped) when placed in the "ON" position. Certain models have dual dockside installation. With a dual dockside installation, one inlet is dedicated to the air conditioner only and the other is for the "AC Main" If so equipped be sure to place the "AIR CONDITIONER circuit breakers on the shore power inlet to "ON" as well as ones on the cabin panel in order to operate. See Figure H30. Refer to Section L-4 - Air Conditioning in this manual for more information regarding the air conditioner.

**Note:** For models with the SEAWATER PUMP circuit breaker, it must be "ON" in order to operate any of the air conditioner(s) that may be installed. See Figure H31.



**Figure H31: Air Conditioner Circuit Breakers**  
(Representative View - Panels Will Vary by Model)

**C. Reverse Polarity Indicator**

Improper grounds or reversed polarity at shore power are a source of serious electrical hazard. On certain models a reverse polarity light (LED) is installed. To indicate if a problem exists at the 120 AC electrical system shore connection.

**NOTICE**

*Some marina shore power systems may be improperly grounded to retard electrolysis (see Section H-11 - Stray Current Corrosion). Before using any 120 volt equipment, make sure the reverse polarity light does not activate when connecting the cord to the inlet.*

If a problem exists, the reverse polarity indicator light will come on when the shore power cable is attached to the inlet. **DO NOT** activate the shore power switch in the cabin when the reverse polarity light is on.



*ALWAYS check the reverse polarity indicator light (if available) in the AC distribution panel immediately upon connecting the shore power cord before turning "ON" the AC SHORE POWER circuit breaker. If the light is on, a problem with a reversed electrical connection exists. Disconnect the shore power cord immediately. Notify the marina and have the dock's shore power connection inspected.*

Under proper operating conditions, the reverse polarity indicator light **will not** be on. On certain models a LED light is provided for the shore power and will be "ON" when dockside power is being used.

#### D. Ground Fault Current Interrupters (GFCI)

The ground fault current interrupter (GFCI) is a device which protects against hazardous electrical shock from improper ground. An appliance electrical cord with worn insulation or damp equipment may have stray current which will run through electrical grounds. Stray current as above will result in an electrical shock.

One GFCI receptacle will protect all of the receptacles on the circuit. A GFCI may be used as a receptacle as well as an interrupter.

To test:

Push the black test button and the red reset button should pop out from the inner surface. The receptacle and the circuit are now off.

Push the reset button in until it clicks to reset it. If it does not reset, there is either a short in the circuit or the equipment or a ground fault in the equipment. Unplug all appliances and reset the GFCI. One at a time, plug the equipment back in and turn it on. The item that causes the GFCI to trip is the problem and should **not** be used.

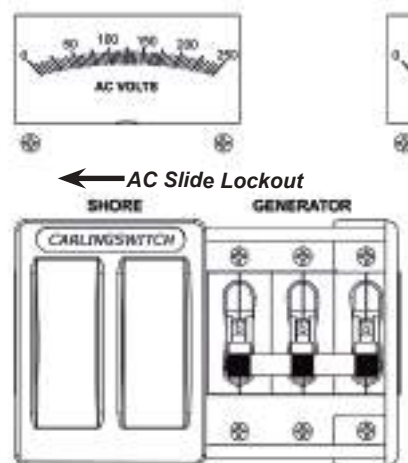
## H - 11 GENERATOR

A gas or diesel generator may be available. It provides 120 volt (230V export) AC power when the boat is away from the dock. The generator can be operated while running at or below cruising speed. Note: The generator should not be operated when the boat is being run at high speeds. **Insufficient cooling water may be available due to the speed.**

A generator is factory installed by Four Winns is capable of providing sufficient power for most electrical needs including cooking, refrigeration, and air conditioning. **Note: It is possible to overload the generator by trying to operate too much equipment at one time.** The circuit breaker that protects the output circuits on the generator set will trip should that occur. See the generator manufacturers information for specifications, operation and additional details regarding the generator.

To use generator power, follow the procedure below:

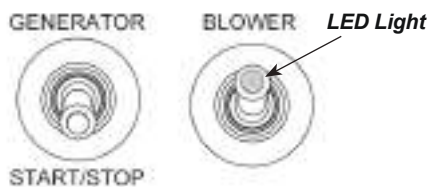
1. Be sure the shore power cable(s) is disconnected and retracted.
2. The breaker switches for the SHORE and GENERATOR AC system must be placed in the OFF position and the AC slide lockout must be moved to cover the SHORE breakers switches. See Figure H32.



**Figure H32: AC Cabin Panel - Main Breakers**  
(Representative View - Panels Will Vary by Model)

4. Check the bilge for fumes. Operate the blower by pressing the remote switch on the panel. Operate blower for at least 4 minutes. Verify blower operation. On most models a LED light on the switch or panel will light up to signify the blower is

operating. **Note:** Follow the procedures indicated on the generator switch panel before starting generator and while running generator. See Figure H33.

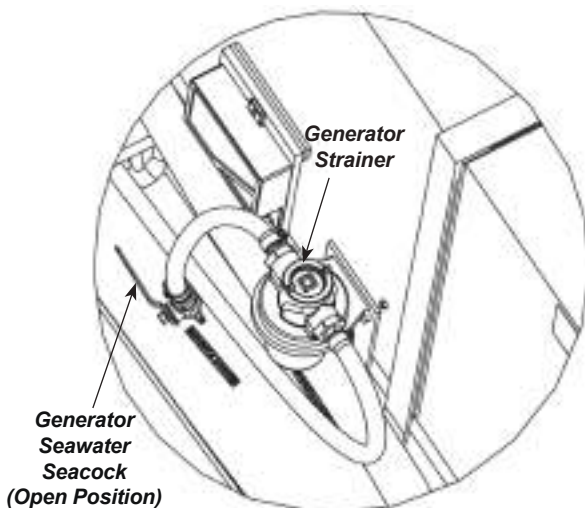


**Figure H33: Remote Generator & Blower Switches**  
(Representative View - Panels Will Vary by Model)



Be sure to operate the bilge blower for at least four (4) minutes before starting engine or generator, or whenever operating the engine(s) at idle speed. Check the bilge blower output before each use.

5. Open the generator's seacock valve, labeled GENERATOR SEAWATER, to allow water flow to the generator for cooling purposes. The seacock is typically located in the engine room next to the generator. See Figure H34.

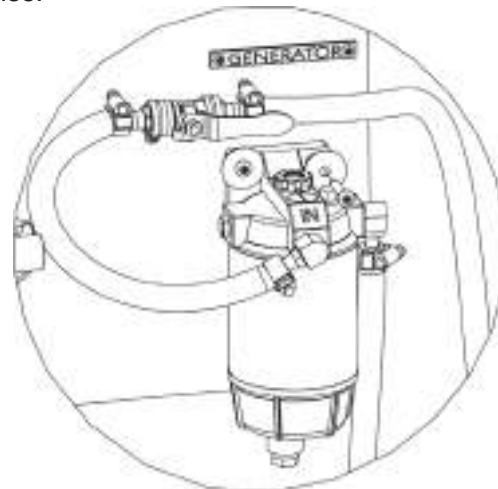


**Figure H34: Generator Seawater Seacock & Strainer**  
(Representative View - Models and Location May Vary)

## NOTICE

In order to use the generator, you must first open the seacock valve (handle parallel to the flow of valve). Failure to open seacock valve while running generator will cause generator to overheat and possible failure. When not using the generator be sure to close the seacock.

6. Open the fuel valve for the generator located in the engine compartment (if applicable). See Figure H35.



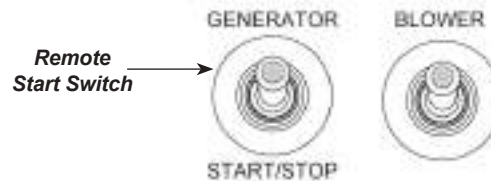
**Figure H35: Generator Fuel Valve**  
(Representative View - Models and Location May Vary)

7. Start the generator using the remote generator start switch on the 240V AC cabin panel. See Figure H36.



GASOLINE VAPORS CAN EXPLODE RESULTING IN INJURY OR DEATH. BEFORE STARTING ENGINES:

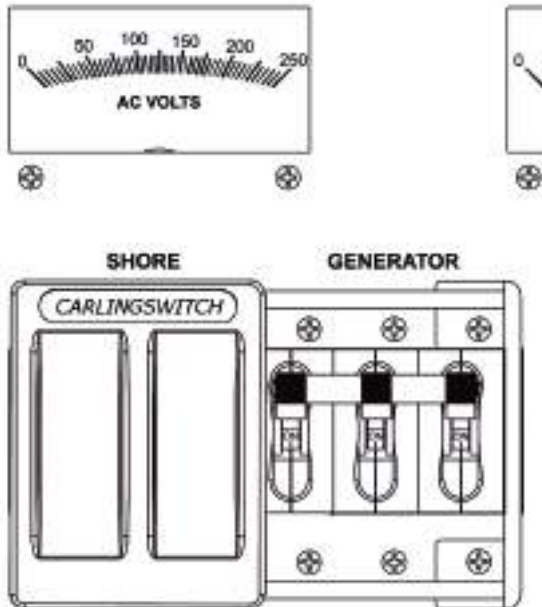
- CHECK ENGINE COMPARTMENT FOR GASOLINE VAPORS.
- OPERATE BLOWERS FOR 4 MINUTES AND VERIFY BLOWER OPERATION.
- RUN BLOWER WHEN VESSEL IS OPERATING BELOW CRUISING SPEED.



**Figure H36: Remote Generator & Blower Switches-"ON"**  
(Representative View - Panels Will Vary by Model)

Generator Emergency Start Procedure: If the house battery fails to start the generator due to low voltage, press and hold the emergency start switch at the helm while simultaneously starting the generator. Current is drawn from the other batteries to start the generator. Once back at port, be sure to have the failed engine battery checked for possible service or replacement.

- Turn the generator's main circuit breakers switches to the "ON" position. See Figure H37.



**Figure H37: Generator Main Breakers - "ON"**  
(Representative View - Panels Will Vary by Model)



Generator exhaust contains carbon monoxide. Review information regarding carbon monoxide at Section B-2 - Carbon Monoxide and Section E-2 - Engine Exhaust.

Periodic generator maintenance as outlined in the generator owner's manual is necessary. Clean the generator strainer periodically or as required. Refer to the manufacturer's literature for more information.

## H - 12 ELECTRICAL SYSTEM MAINTENANCE

### A. Battery Maintenance

Be sure to keep the batteries charged. Also, keep the batteries clean, especially the terminals and connection lugs. Be sure the batteries are fastened securely while in use.

Check the battery fluid level often, especially when a charger/converter is being used. Replenish a battery indicating a low charge. Determine the reason for the discharge. Lack of battery usage is as detrimental to battery longevity as is overuse. Alternating battery usage is important. Refer to the battery manufacturer's instructions included with your battery.



Batteries produce hydrogen and oxygen gases when being charged. These explosive gases escape through the vent/fill caps and may form an explosive atmosphere around the battery if the ventilation is poor. This gas may remain around the battery for several hours after charging. Sparks or flames can ignite the gas and cause an explosion.



#### Fire or Explosion Hazard!

Only qualified personnel should install batteries and perform electrical system maintenance. Do not expose batteries to open flame or sparks. Do not smoke near batteries.



#### Poison!

Sulfuric acid in batteries can cause severe burns. Avoid contact with skin, eyes, or clothing. Wear goggles, rubber gloves and protective apron when working with batteries. In case of skin contact, flush with water at least 15 minutes. If swallowed, drink large quantities of water or milk. Follow with Milk of Magnesia, beaten egg or vegetable oil. Get medical attention immediately.



Disconnect the battery before working on electrical or ignition system to prevent electrical shock and accidental ignition.

## B. Electrical Wiring Maintenance

Periodically, inspect all wiring for nicks, chaffing, brittleness, improper support, etc. Check all AC and DC wiring connections to be sure they are secure and free of corrosion. Spraying the receptacles and electrical connections with an electrical connection cleaner will reduce corrosion and improve electrical continuity.



*DO NOT allow corrosion to build up on connections. Shorts or ground faults can result.*

Depending on the model, the entire AC circuitry, especially the shore power cable, should be seasonally tested for proper continuity by an experienced marine electrician. This will help detect any short, open wire, or ground fault.



*120VAC & 240VAC (230VAC-export) electrical power can be dangerous. DO NOT attempt to service a system unless you are familiar with, and experienced in, performing such service.*

Periodically, inspect the exterior jacket of your shore power cable for nicks or cuts. For Cablemaster users, experience has shown that when only a short section of the power cable is used regularly, the cable may be subject to sharper than normal coiling. This in turn causes undue “kinking” of the cable. To relieve this condition, routinely pay the cable out completely and stretch it on any smooth surface. Allow the Cablemaster to then retract the cable into the cable storage area. Check the neoprene covers on the in-limit switch and power switch to be sure they are free of cracks or fracture. If your shore power cable is dirty DO NOT USE any cleaner that will leave a waxy film on the shore power cable. The waxy film will cause slippage between the Cablemaster’s main pulley and your shore power cable. It is recommended to use a mild soap and water to clean your cable.

## H - 13 STRAY CURRENT CORROSION

### A. General

Electrically induced underwater corrosion occasionally affects boats and their related components. This is referred to as “Stray Current Corrosion” and appears as surface pitting or deterioration. Stray current corrosion is the decomposition of chemical compounds by electric current.

Stray current corrosion can be caused by surrounding boats; an improperly wired battery/charger installation or other boats that are in close proximity which have electrical power leakages. Stern drive units are especially vulnerable to stray current corrosion. Periodically inspect the engine components to determine if corrosion damage exists. If stray current corrosion damage is found, determine and correct the cause of the stray current to prevent further damage. Consult an experienced marine electrician or contact your Four Winns dealer for assistance.

The use of some shore power battery chargers, while the boat is in the water and the battery is connected to the system, can cause stray current corrosion. Have an experienced marine electrician review any battery charger installation to ensure a stray current corrosion problem will not develop. An improper battery connection is a common cause of stray current corrosion.

### NOTICE

*Use only UL Marine-ignition protected battery charger(s) designed to meet US Coast Guard regulations for external ignition protection.*

Corrosion is usually more prevalent in polluted or salt water than in fresh water. It is also more likely to occur when dockage is in an area with steel piers, large metal boats, or where shore power is in use.

### B. Galvanic Corrosion

Galvanic corrosion results from a potential electrical difference existing between dissimilar metals immersed in a conductive solution (e.g., salt or brackish water). If these metals touch or are otherwise electrically connected, this potential difference produces an electron flow between them. The attack on the more active metal is usually increased and the attack on the less active metal is decreased, as compared to when these metals are not touching.



### C. Corrosion Prevention

Anticorrosion anodes are attached to the transom to prevent corrosion to your electrical systems and underwater parts. These anodes will be slowly eroded away by galvanic action and require periodic inspection. Please refer to the section on “Anti-Corrosion Anodes” in your engine manufacturer’s manual for additional information.

#### **NOTICE**

*Four Winns continually strives to improve its products. Unit specifications, including standard and optional equipment are constantly being modified. Equipment availability is also subject to change without notice. The most current and accurate information available at the time of publication is included in this manual. Some variation in equipment, description, location, and details can result. Please refer to the manufacturer’s literature in the owner’s packet.*



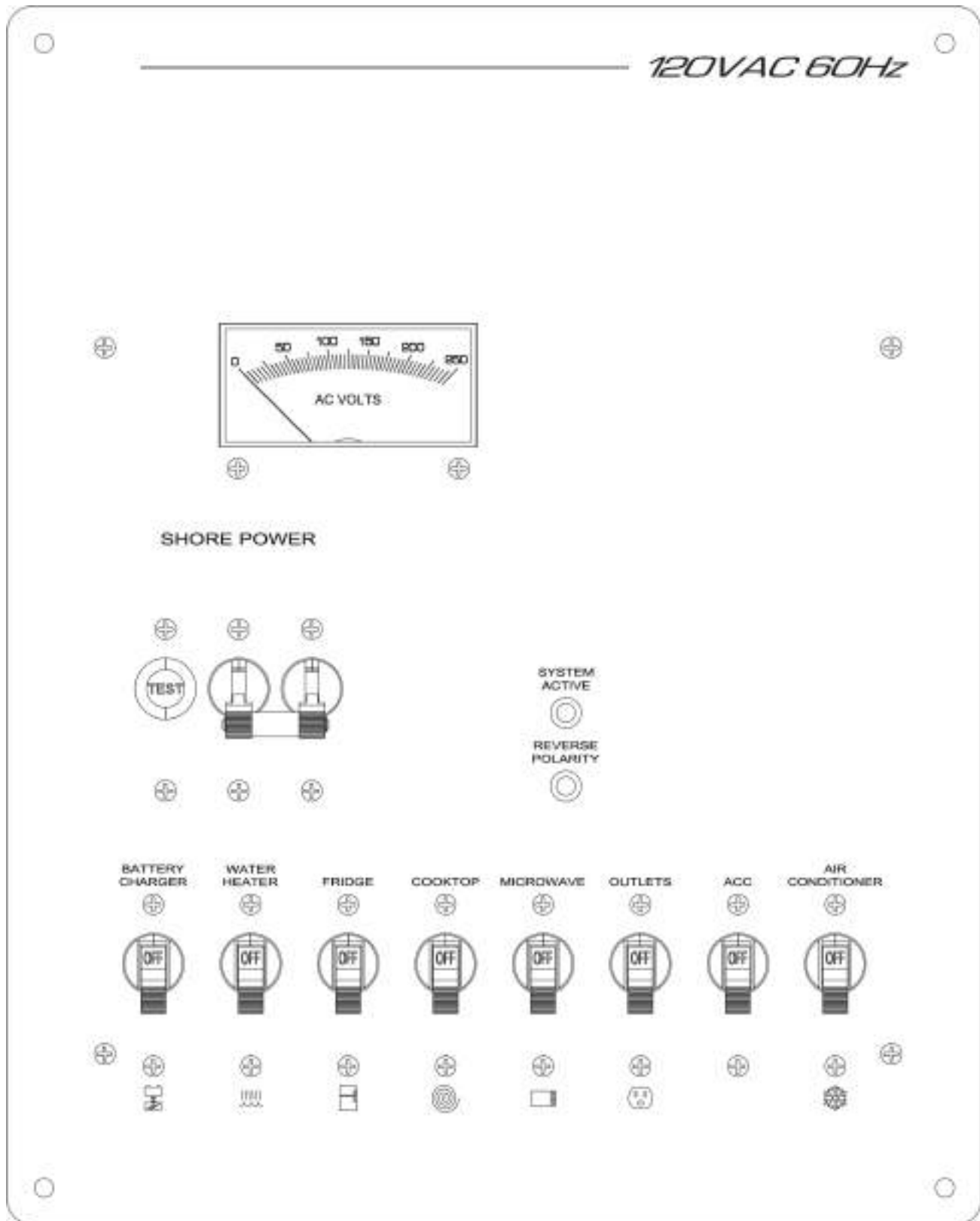


Figure H38: 120 VAC Cabin Panel

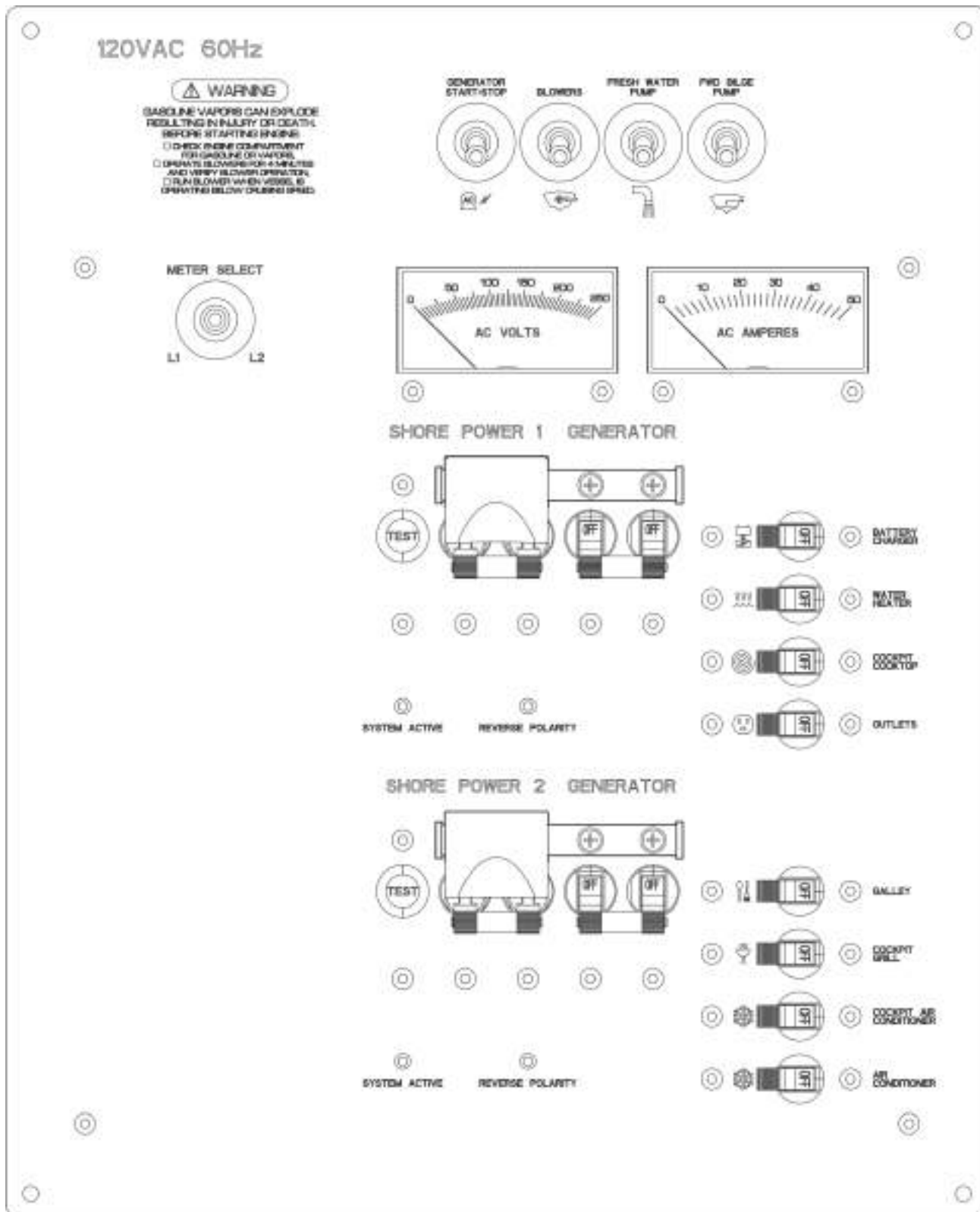


Figure H39: 120 VAC Cabin Panel

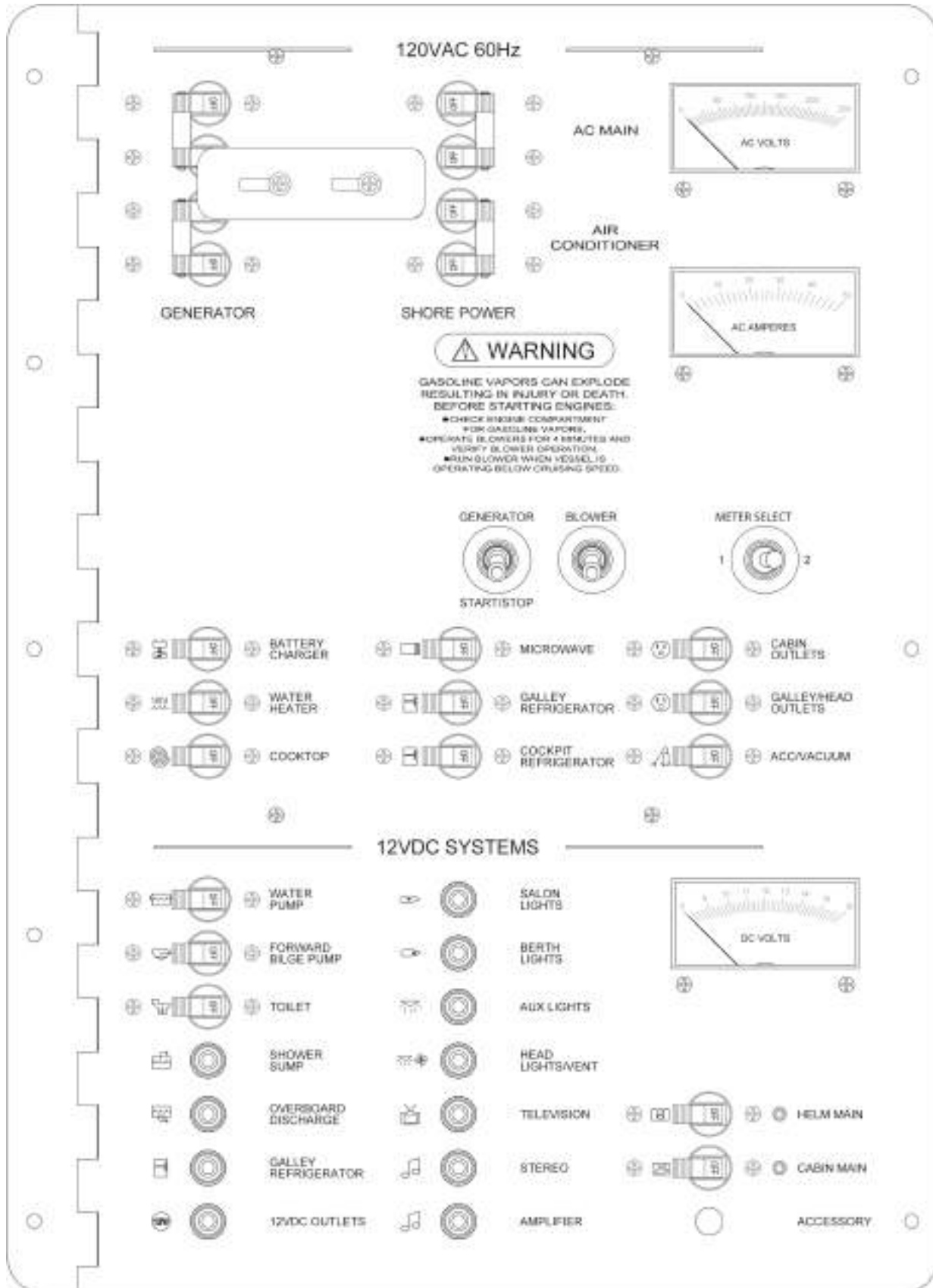
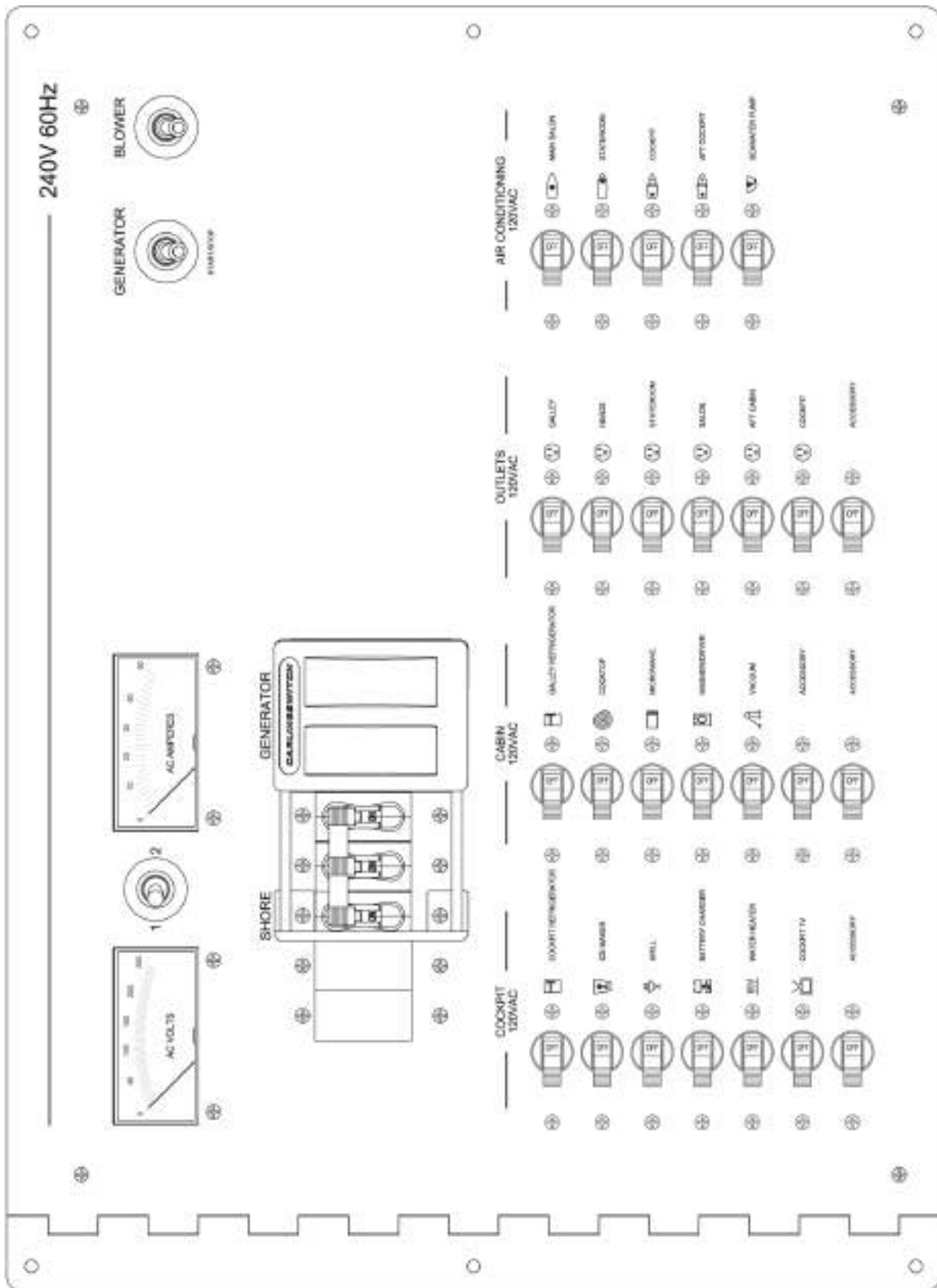


Figure H40: 120 VAC Cabin Panel



**Figure H41: 120 VAC Cabin Panel**

**I - 1 FUEL SYSTEMS**
**A. Gasoline Fuel System**
**NOTICE**

*Fuel systems used in Four Winns® boats are designed to meet or exceed the requirements of the Environmental Protection Agency (EPA), US Coast Guard, California Air Resources Board (CARB), the National Marine Manufacturers Association, and the American Boat and Yacht Council in effect at the time of manufacture.*

These V series models, whether single or twin tanks include an integrated fuel system. See Figure I1. As the fuel tank(s) is filled with gasoline, pressure rises in the fuel tank. To prevent over-pressurization, the fuel limit vent valve expels pressure (which includes gas vapors) that travel through the fuel vent hose and out the fuel fill/vent. See Figure I1.

When a predetermined level has been reached the fuel limit vent valve shuts off. Pressure quickly builds in the tank and the fuel fill inlet control closes. Fuel no

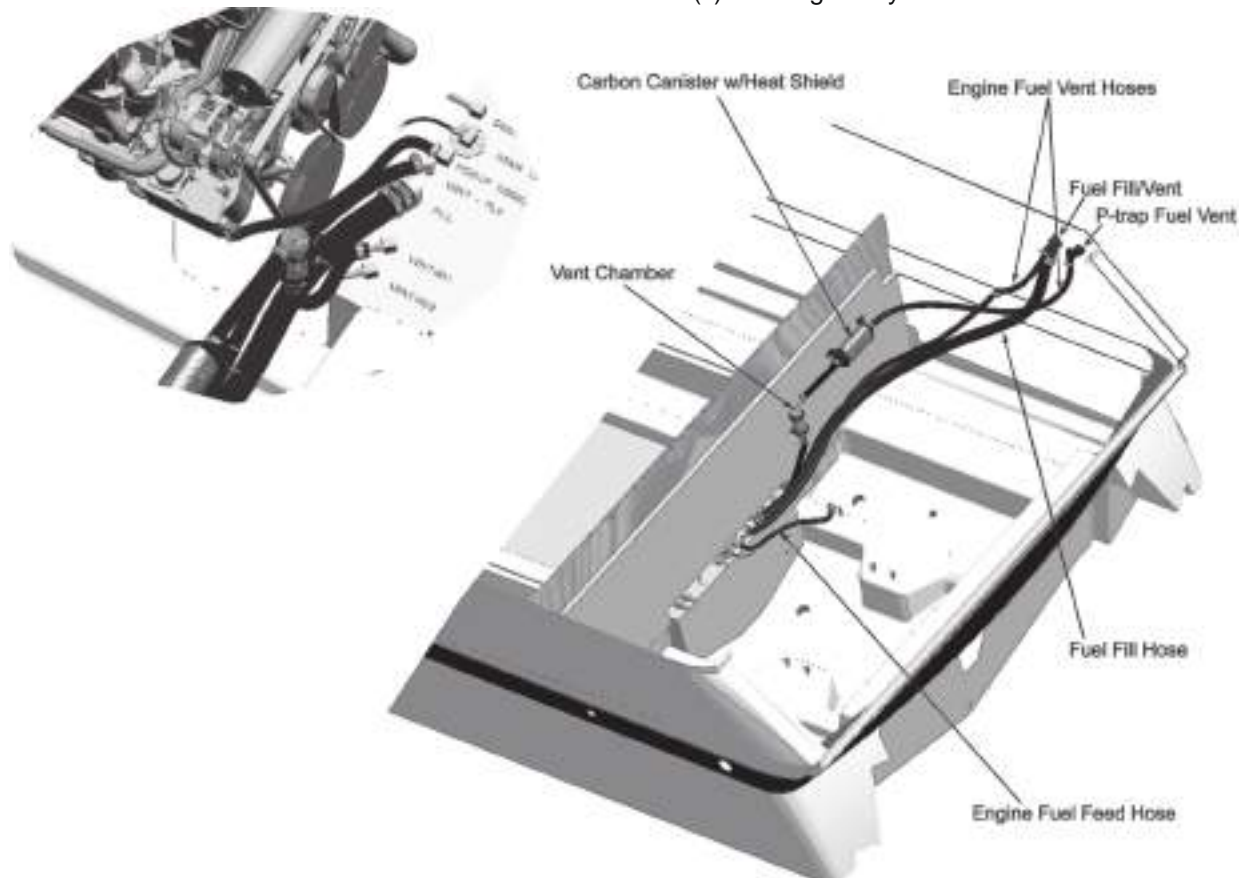
longer can enter the tank. As the fuel level rises in the fill hose it shuts off the fuel flow from the fuel nozzle (just like when you fill your car's fuel tank).


**WARNING**

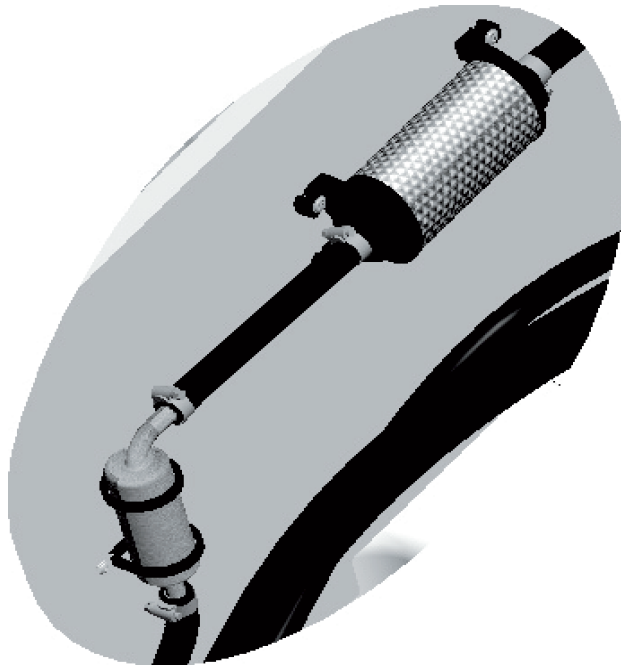
*Avoid overboard spills. Be alert. The fuel nozzle should automatically shut off when using an automatic shut off nozzle. Be ready in the event it does not or if you are using a different type of nozzle for dispensing fuel. **DO NOT TOP OFF.***

When the pressure reduces in the fuel tank the fuel fill inlet control opens and allows the remaining fuel in the fuel line to drain into the fuel tank.

It should also be noted that when the air temperature rises so does the pressure in the fuel tank. When this happens, the pressure is released through the grade valves depending upon the level of the fuel in the tank. The gas vapors are scrubbed by the carbon canister before being released into the air through the fuel P-trap vent(s). See Figures I1 & I2. As the temperature drops, air is brought back in through the fuel P-trap vent(s) allowing the system to breath.



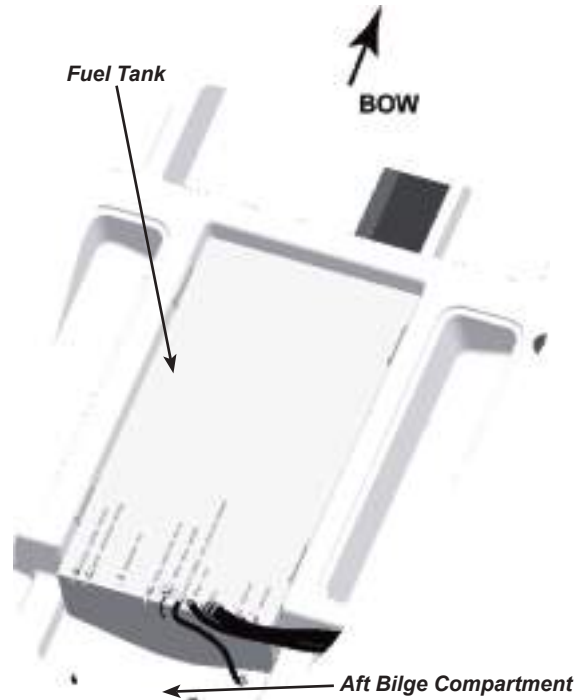
**Figure I1: Fuel System Components & Hose Routing**  
(Single Fuel Tank Shown - Representative View - Models May Vary)



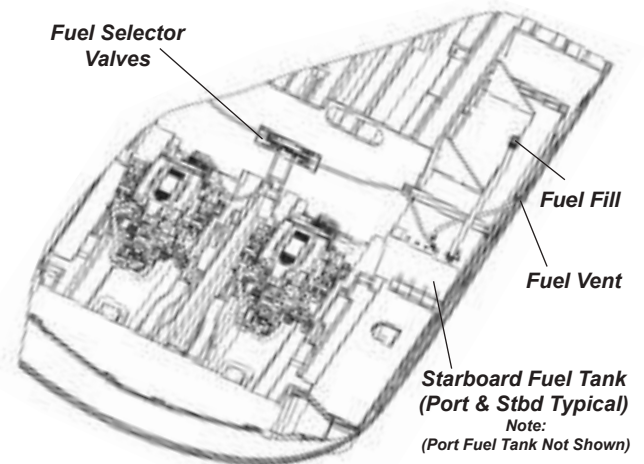
**Figure 12: Carbon Canister w/Heat Shield**  
(Representative View - Models May Vary)

On V series models, with a single fuel tank installed, the location of the tank is forward of the aft bilge compartment below the floor. See Figure 13. In twin engine applications, the port and starboard fuel tanks are located forward and outboard in relationship to their respective engine. See Figures 14. The capacity of the fuel tank(s) may be found on our website at [www.fourwinns.com](http://www.fourwinns.com).

These V series models equipped with twin fuel tanks come with a manual fuel valve system. This fuel valve system allows you to manually select which fuel tank you want your engines to draw fuel from. The generator (if applicable) uses a separate fuel pick-up (not shown). Please see Figure 120 at the end of this section for fuel valve operations.



**Figure 13: Single Fuel Tank Location**



**Figure 14: Twin Fuel Tank Locations**

#### NOTICE

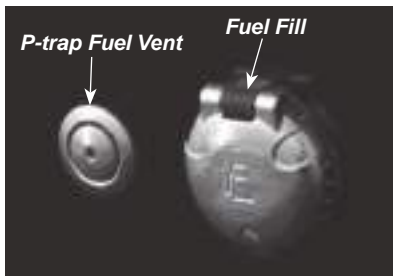
Use only clean fuel of the type and grade recommended by the engine manufacturer. Engine damage resulting from the use of a lower octane gasoline is considered misuse of the engine and will void the engine warranty. Refer to the section on gasoline requirements in the engine manual for information on octane specifications.

## B. System Testing

All gasoline fuel systems have been factory inspected and pressure tested in accordance with regulations in effect at the time of manufacture. Additionally, each fuel tank must pass rigid tests and inspections performed by the fuel tank manufacturer. Prior to taking delivery, it is important that a full inspection be made of the entire fuel system by the selling dealer. An entry on the Four Winns® Pre-Delivery Inspection Form portion of the online Warranty Registration will attest to the dealer's performance of this service.

## C. Fuel Fills

Fuel deck fills are located either on the aft deck or side decks, and are clearly marked with a fuel symbol or are labeled "GAS". See Figures I5 & I6. The fuel deck fill is hinged to prevent loss. The deck fill is vented to prevent the fuel tank from becoming over-pressurized during refueling. It is designed for nozzle retention and are automatically shut-off compatible (domestic models only). The water-resistant gas cap prevents water from entering the fuel system.



**Figure 15: Fuel Deck Fill & Fuel Vent**  
(Representative View - Location and Type May Vary)

The "click-to-close" gas cap allows for ease of use. To open, push the catch/release mechanism shown in Figure I6 inward. To close, simply shut the cap and press the cap until it "clicks" shut. Hearing the click ensures that the gas cap is completely closed. Be sure to utilize the proper type and grade of fuel as recommended by the engine manufacturer. See Section I-3 for additional information.



**Figure 16: Fuel Deck Fill**  
(Representative View - Models May Vary)

### WARNING

Avoid overboard spills. Be alert. The fuel nozzle should automatically shut off when using an automatic shut off nozzle. Be ready in the event it does not or if you are using a different type of nozzle for dispensing fuel. **DO NOT TOP OFF.**

### NOTICE

All connections, including the fuel deck fill, should be checked annually for leaks.

### WARNING

DO NOT confuse GAS deck fill plate with WATER or WASTE deck plates. Deck fill plates are labeled according to the intended use.

### WARNING

Spilled fuel is a fire hazard. DO NOT overfill or overflow the tank, or allow fuel spills into the hull or bilge. If spillage occurs, clean up immediately and dispose of soiled rags/towels in a proper container.

### NOTICE

When fueling at a marina, DO NOT overfill. Fuel may spill into the water.

After fueling, close the fill cap, and wash the areas around the fuel fill plate. Residual fuel left on the deck and hull sides can be dangerous and will yellow the



fiberglass. It can also damage the tape stripes and logos. Care should be taken, when cleaning, to prevent contaminating the fuel deck fill/vent. Cleaning with only mild soapy water is recommended.

The gasket seal on the fuel fill cap assists in sealing when closed. A missing or damaged gasket can allow water on the surrounding surfaces to run into the tank. Periodically inspect the gasket (if applicable) and/or the fuel deck cap for damage.

#### D. Fuel Vent (P-trap)

On the V series models, separate thru-hull P-trap fuel vent(s) is installed. See Figures I5 & I7. During normal boating operations and/or temperature increases, air from the fuel tank is displaced and escapes through the vent overboard. Before being released into the environment the gas vapor is scrubbed by a carbon canister thus greatly reducing emissions.



**Figure 17: P-trap Fuel Vent**  
(Representative View - Models May Vary)

When it comes to maintenance of the fuel vent the manufacturer has provided the following information and maintenance instructions.

You will know the vent needs maintenance if vapor rushes into or out of fuel tank when you open deck fill cap. You may also notice difficulty while fueling (back-splash or pump shutting off continuously during fill).

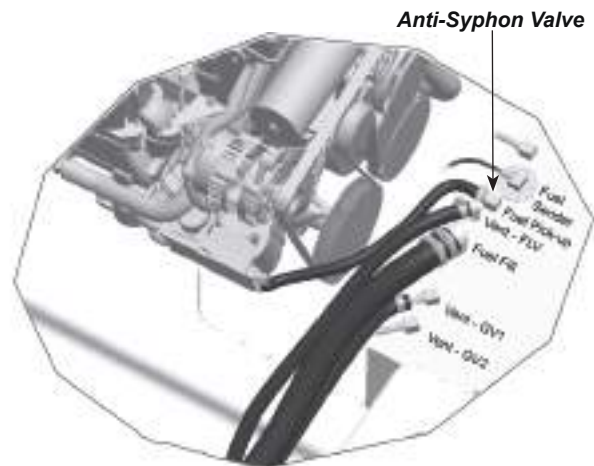
Debris and spider webs can block the vent, especially after storage. Use these steps to clean vent screen before and after storage, or at least once a year.

This maintenance should be done while the boat is out of the water. This way you do not risk losing parts.

1. Use a 3/16" (5mm) hex wrench to turn cap off counter-clockwise. Set cap aside for re-installation
2. When cleaning, DO NOT allow debris to fall down the vent tube into tank.
3. Remove screen and clean with solvent or air pressure. **Be sure not to puncture the screen.**
4. Replace screen in original position. 5. Replace and tighten vent cap (30-to-35 in./lb. torque, 3.39 to 3.95N.Meters). **Do not over-tighten.**

#### E. Anti-Syphon Valve

The fuel withdrawal line is equipped with an anti-syphon valve where the line attaches to the fuel tank. This valve prevents gasoline from syphoning out of the fuel tank should a line rupture. See Figure I8 for anti-syphon location.



**Figure 18: Fuel Tank Fittings**

#### CAUTION

The fuel withdrawals are positioned in the fuel tanks to achieve optimum fuel usage, and fuel line routing. At certain speeds and hull trim angles, the fuel supply at the withdrawal tank location can increase or decrease accordingly. Be extremely careful when attempting to operate the boat on a minimum amount of fuel. Though some fuel may be in the tank, the relative trim angle of the boat may cause the fuel to flow away from the withdrawal.

**NOTICE**

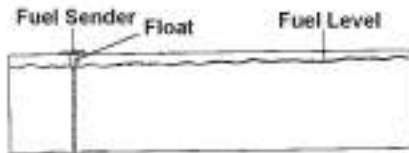
Access plates or lids are provided in the floor for easier access to the fuel pick-up, anti-syphon valve and sender.

**F. Fuel Gauge**

The fuel gauge indicates the amount of fuel in the tank. See Section E-8F - Fuel Gauge for additional information on fuel gauge use.

**G. Fuel Sender**

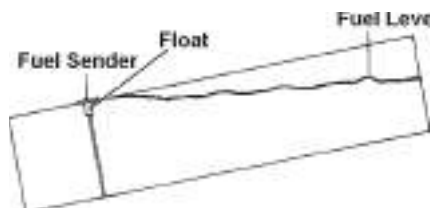
The fuel sender consists of a float which travels up and down a stationary tube. The float measures the level of the fuel in the tank and sends a signal to the fuel gauge. See Figure I9.



**Figure I9: Fuel Sender Operation**

Due to the mechanical nature of the fuel sender, variations in readings during various speeds of operation may occur. This system is merely a relative indication of the available fuel supply and not a calibrated instrument. With this type of sending unit a more accurate measurement of fuel level is obtained with the boat in a level position.

The gauge readings will also vary with the trim angle of the boat. When sitting at a dock and the boat is nearly level, the fuel gauge will register accurately. Refer to Figure I9. When boating, the trim angle of the boat changes and affects the gauge readings. Under these conditions, the fuel sender will register “full” for the first few hours of running time until the fuel level drops below the 3/4 or 1/2 mark. This is caused by the angle of the fuel in the tank as shown in Figure I10.

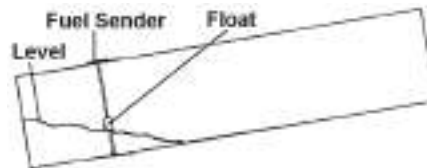


**Figure I10: Effects of Trim Angle**

It is very important to keep track of hours and fuel consumption to obtain an average gallon per hour consumption figure. Refer to the fuel log located at the back of this manual. This will help to prevent any problems with running out of fuel on the water.

Dealers are equipped with some general figures on consumption which can be used as a guide until specific information on your boat is determined. Because of boating conditions, speed, weight and other factors common to your situation, fuel consumption will vary between your boat and consumption figures developed by Four Winns.

When the fuel gauge begins to register below the “Full” mark, the gauge readings will drop much faster until it reads “empty”. When this occurs, the trim angle has affected the sender reading. When the gauge registers “empty”, the sender has bottomed out and there may be 3 to 4 gallons of fuel in the tank. See Figure I11.



**Figure I11: Trim Angle Effect with Low Fuel**

**H. Fuel Filters**

Fuel filters are installed on each engine. Filters should be changed frequently to assure an adequate supply of fuel to the engine. Refer to the engine manual for additional information. The engine manual is included in the owner’s information packet.

**NOTICE**

Canister-type filters should be changed annually.

**I. Gas Vapor Detector**

A gas vapor detector may be available on certain models. If equipped, the gas vapor detector will monitor the engine compartment and notify the operator of an accumulation of gasoline vapors. The operator must take immediate action upon warning to avoid the possibility of an explosion.

The sensing unit is usually mounted towards the rear of the engine compartment. The alarm unit is mounted at the dash.

**⚠ WARNING**

Always personally inspect the engine compartment and sniff for fuel vapors before starting the engine. Remember, a gas vapor detector is a mechanical device. DO NOT rely exclusively on its operation.

## J. Use and Maintenance

**⚠ WARNING**

DO NOT let the odor of gasoline go unchecked. If the odor of gasoline is noted, DO NOT START ENGINE. If engine is running, SHUT OFF ENGINE, ELECTRICAL AND HEAT GENERATING EQUIPMENT. Investigate and correct the situation immediately! Have all passengers put on personal flotation devices and keep fire extinguishers at hand until the situation is resolved.

**⚠ WARNING**

Avoid serious injury or death from fire or explosion resulting from leaking fuel. Inspect systems for leaks at least once a year.

**⚠ WARNING**

To help guard against damage, avoid the storage or handling of gear near the fuel lines, fittings and tanks.

**⚠ WARNING**

DO NOT attempt installation or maintenance of any fuel system equipment unless thoroughly familiar with the systems and experienced in making such installations or maintenance. Only qualified personnel should perform fuel system maintenance.

## I - 2 DIESEL FUEL SYSTEMS - TWIN

The diesel fuel system used in certain V series models is designed to meet or exceed the requirements the National Marine Manufacturers Association and the American Boat and Yacht Council in effect at the time of manufacture.

In twin diesel engine applications, the port and starboard fuel tanks are located forward and outboard in relationship to their respective engine. See Figure I12.

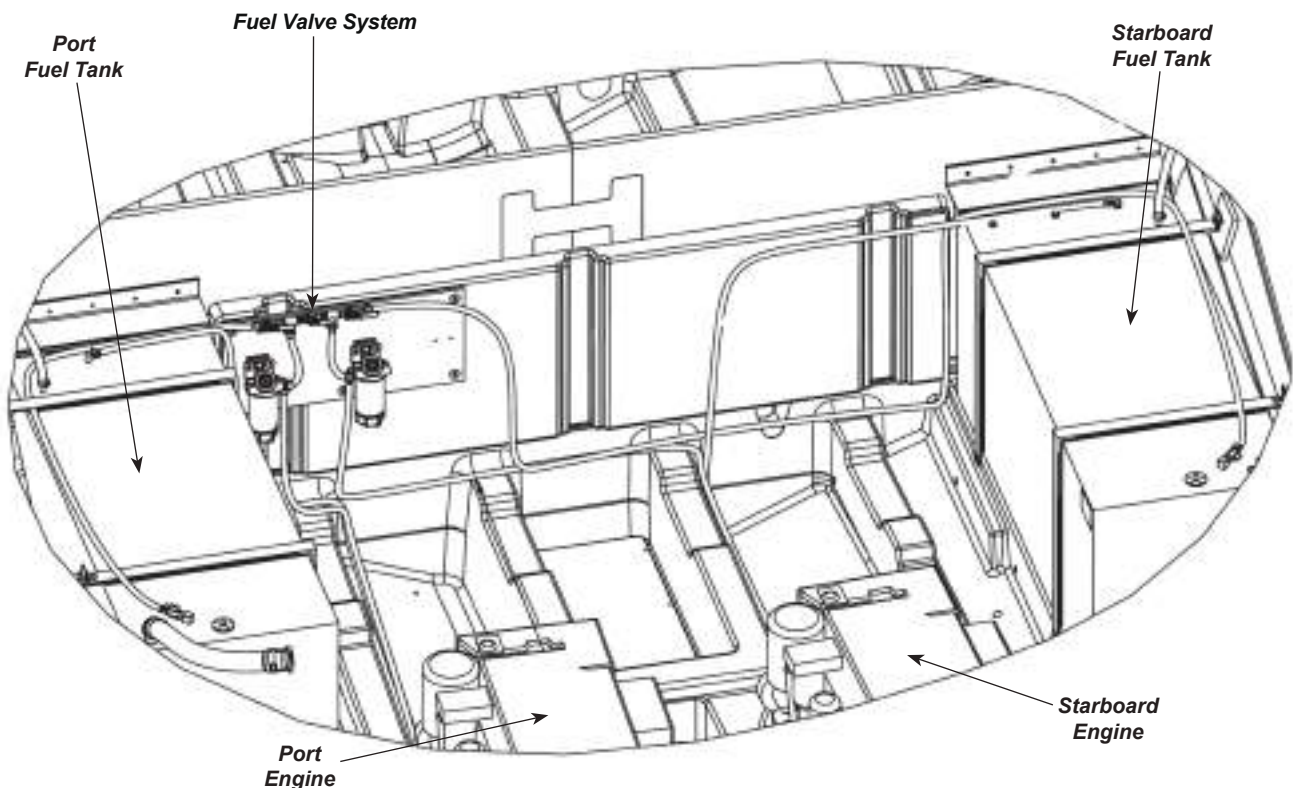


Figure I12: Twin Fuel Tank Locations

The capacity of the fuel tank(s) may be found on our website at [www.fourwinns.com](http://www.fourwinns.com).

#### NOTICE

*Use only clean, dry fuel of the type and grade recommended by the engine manufacturer. The use of incorrect or contaminated fuel can cause engine malfunction and serious damage. Engine damage resulting from the use of incorrect fuel is considered misuse of the engine and will void the engine warranty. Refer to the section on Fuel Requirements in the engine manual for information on fuel specifications.*

The V series models equipped with twin fuel tanks come with a manual fuel valve system. See Figure I12. This fuel valve system allows you to manually select which fuel tank you want your engines to draw fuel from. The diesel generator (if applicable) uses a separate fuel pick-up (not shown). Please see Figure I20 at the end of this section for fuel valve operations.

#### A. System Testing

All fuel systems have been factory inspected and pressure tested in accordance with regulations in effect at the time of manufacture. Additionally, each fuel tank must pass rigid tests and inspections performed by the fuel tank manufacturer.

Prior to taking delivery, it is important that a full inspection be made of the entire fuel system by the selling dealer. An entry on the Four Winns Pre-Delivery Inspection Form portion of the Warranty Registration Card will attest to the dealer's performance of this service.

#### B. Fuel Fills

The fuel fill deck plates are located on the port and starboard at the transom and are marked "DIESEL". See Figure I13. Be sure to utilize the proper type and grade of fuel as recommended by the engine manufacturer. To open, insert the deck plate key into the holes on the cap and rotate counterclockwise. A bead chain connects the cap to body to help prevent loss overboard. Refer to Section I-4 for information regarding fueling instructions.



**Figure I13: Starboard Fuel Fill Location (Port & Stbd Typical)**



**DO NOT** confuse FUEL deck fill plate with WATER or WASTE deck plates. Deck fill plates are labeled according to the intended use.

The gasket/O-ring seals on the fuel fill cap assist in sealing when closed. A missing or damaged O-ring can allow water on the surrounding surfaces to run into the tank.

Periodically inspect the cap and the fuel deck plate. The O-ring seal should be inspected for cracks or damage and replaced as necessary. Lubricating with a light, waterproof oil or grease is recommended and can extend the O-ring's longevity.

#### C. Fuel Vents

Separate thru-hull fuel vents are installed. See Figure I14. While the tank is being filled, the air displaced by the fuel escapes through the vent overboard.



**Figure I14: Port Fuel Vent Location (Port & Stbd Typical)**

**WARNING**

Spilled fuel is a fire and explosion hazard. DO NOT overfill or overflow the tank, or allow fuel spills into the hull or bilge. If spillage occurs, clean up immediately and dispose of soiled rags/towels in a proper container.

**WARNING**

Avoid overboard spills. When tank is almost full the sound from the fuel fill/vent will change. The pitch will become higher indicating the tank is close to being full. Stop pumping fuel into tank. **DO NOT TOP OFF.**

**NOTICE**

When fueling at a marina, DO NOT overfill. Fuel may spill into the water.

After fueling, replace the fill cap, and wash the areas around the fuel fill plate and below the fuel vent. Residual fuel left on the deck and hull sides can be dangerous, and will yellow the fiberglass. It will also damage the tape stripes and logos.

For those models with thru-hull venting, periodically, inspect the fuel vent(s) for any dirt, wax, etc. Please follow the manufacturer's recommended maintenance schedule and maintenance instructions located in Section I-1D.

#### D. Fuel Pick-Up

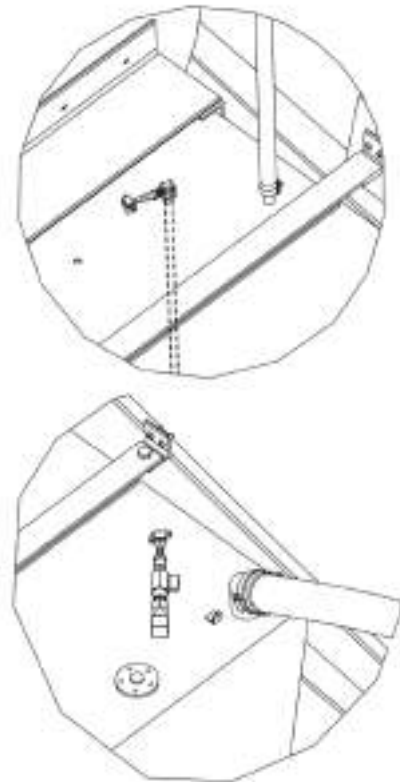
The fuel withdrawal line attaches to the fuel tank at the fuel pick-up. See Figure I15 for fuel pick-up location.

**CAUTION**

The fuel withdrawal is positioned in the fuel tank to achieve optimum fuel usage, and fuel line routing. At certain speeds and hull trim angles, the fuel supply at the withdrawal can increase or decrease accordingly. Be extremely careful when attempting to operate the boat on a minimum amount of fuel. Though some fuel may be in the tank, the relative trim angle of the boat may cause the fuel to flow away from the withdrawal.

**NOTICE**

On certain V series models, access to the fuel fittings is through the engine compartment.



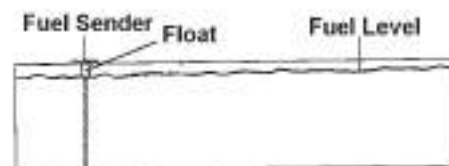
**Figure I15: Starboard Fuel Tank Fittings Shown (Port & Stbd Typical)**

#### E. Fuel Level

The amount of fuel in the fuel tanks can be determined by either the fuel gauges or accessed through the Electronic Vessel Control (EVC) system (if applicable). An EVC display for each engine is mounted at the helm and monitors their respective systems to include fuel level. Refer to the manufacturer's literature included in your owner's packet for specific information regarding ECV operation and information display (if applicable).

#### F. Fuel Sender

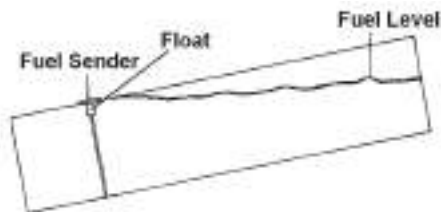
The fuel sender consists of a float which travels up and down a stationary tube. The float measures the level of the fuel in the tank and sends a signal to the EVC display or fuel gauges. See Figure I16.



**Figure I16: Fuel Sender Operation**

Due to the mechanical nature of the fuel sender, variations in readings during various speeds of operation may occur. This system is merely a relative indication of the available fuel supply and not a calibrated instrument. With this type of sending unit a more accurate measurement of fuel level is obtained with the boat in a level position.

The display readings will also vary with the trim angle of the boat. When sitting at a dock and the boat is nearly level, the fuel display will register accurately. Refer to Figure 17. When boating, the trim angle of the boat changes and affects the gauge readings. Under these conditions, the fuel sender will register “full” for the first few hours of running time until the fuel level drops below the 3/4 or 1/2 mark. This is caused by the angle of the fuel in the tank as shown in Figure 17.

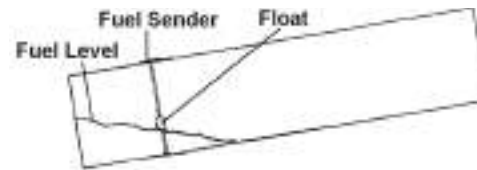


**Figure I17: Effects of Trim Angle**

It is very important to keep track of hours and fuel consumption to obtain an average gallon per hour consumption figure. Note: The EVC display can be set to show the fuel consumption rate. Use the fuel log located at the back of this manual to assist in keeping track of the fuel consumption rate. This will assist in preventing any problems with running out of fuel on the water.

Dealers are equipped with some general figures on consumption which can be used as a guide until specific information on your boat is determined. Because of boating conditions, speed, weight and other factors common to your situation, fuel consumption will vary between your boat and consumption figures developed by Four Winns.

When the fuel begins to register below the “full” mark, the display readings will drop much faster until it reads “empty”. When this occurs, the trim angle has affected the sender reading. When the display registers “empty”, the sender has bottomed out and there may be 3 to 4 gallons of fuel in the tank. See Figure I18.



**Figure I18: Trim Angle Effect with Low Fuel**

## G. Fuel Filters

Fuel filters are installed on each engine. Filters should be changed frequently to assure an adequate supply of fuel to the engine. Refer to the engine manual for maintenance schedule as well as the procedure for changing the fuel filter. The engine manual is included in the owner’s information packet.



*DO NOT attempt installation or maintenance of any fuel system equipment unless thoroughly familiar with the systems and experienced in making such installations or maintenance. Only qualified personnel should perform fuel system maintenance.*

## H. Use and Maintenance



*DO NOT let the odor of fuel go unchecked. If the odor of gasoline is noted, DO NOT START ENGINE. If engine is running, SHUT OFF ENGINE, ELECTRICAL AND HEAT GENERATING EQUIPMENT. Investigate and correct the situation immediately! Have all passengers put on personal flotation devices and keep fire extinguishers at hand until the situation is resolved.*



Avoid serious injury or death from fire or explosion resulting from leaking fuel. Have fuel system inspected for leaks, check conditions of all rubber hoses and re-tighten hose clamps every 200 hours or at least once a year by an authorized service facility.

If areas are found within the fuel system that appear questionable, have a qualified marine technician inspect the system. A thorough fuel system examination should be made by an experienced marine technician at least once a year.



*To help guard against damage, avoid the storage or handling of gear near the fuel lines, fittings and tanks.*

### I - 3 FUEL STANDARDS

Be cautious when using gasoline that contains alcohol. The fuel system components on the plastic fuel tanks used by Four Winns® will withstand up to 10% alcohol content in the gasoline. Also refer to the section on gasoline requirements in your engine manual for additional information.



*To conform to Federal Air Quality Standards, the petroleum industry reduced the amount of tetraethyl lead in gasoline. Alcohol is being blended with gasoline to help restore the octane rating lost when the lead was removed. While blending alcohol with gasoline increases the octane level of the fuel, it can also create certain safety and performance related problems for boaters.*

#### A. Problems with Alcohol in Gasoline

Below is a list of problems which may be experienced when using blended gasoline.

1. Premature deterioration of fuel system components may occur. Alcohol will attack rubber fuel hoses, fuel tanks, fuel filters, fuel pumps and rubber gaskets. This deterioration will lead to fuel system leakage.
2. Phase separation of fuel will cause contamination. Water which accumulates in the tank through contamination or condensation will be absorbed by the alcohol. This water-heavy alcohol will settle at the bottom of the tank. This phase separation will lead to fuel tank corrosion. This may also result in a lean mixture to the carburetor and cause engine stalling or possible engine damage.

The use of alcohol additives in gasoline has become more widespread. Regulations on public notification of the existence of additives is currently controlled by the Environmental Protection Agency (EPA). Some states do require that gasoline pumps display information on

additives (especially alcohol). If alcohol content is not posted, ask and avoid using fuel containing alcohol if possible.

#### B. Recommendations

Assume blended gasoline is being used and follow these recommendations below.

1. Inspect fuel hoses often. A deteriorated hose containing alcohol blended gasoline will normally be soft and swollen. A deteriorating hose containing no fuel will normally be hard and brittle. In both cases the hose should be replaced.
2. Ventilate the engine compartment before starting the engine. Operate the engine compartment blower for four (4) minutes. Then, prior to starting the engine, check the bilge area for the scent of gasoline fumes; DO NOT start the engine if the odor of gasoline is detected.
3. Frequently inspect the fuel system fittings. Inspect the fuel tank, pump and filter for signs of leaks or corrosion. Visually inspect for deteriorating metal fittings at the fuel hose connections.



*Avoid serious injury or death from fire or explosion resulting from leaking fuel. Inspect system for leaks at least once a year.*

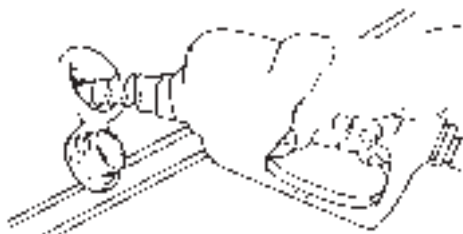
If areas are found within the fuel system that appear questionable, have a qualified marine technician inspect the system. A thorough fuel system examination should be made by an experienced marine technician at least once a year.

### I - 4 FUELING INSTRUCTIONS

1. Avoid fueling at night except in emergencies.
2. When moored at fueling pier:
  - a. Do not smoke, strike matches, or throw switches.
  - b. Stop all engines, motors, fans, and devices that could produce sparks.
  - c. Put out all lights and galley stove.

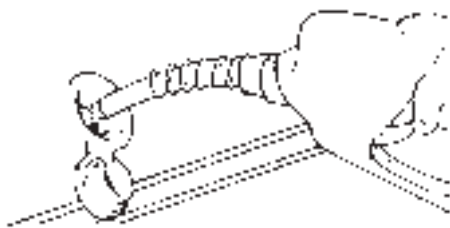
- d. On the DC cabin panel place the HELM MAIN and CABIN MAIN breaker switches to OFF position.
3. Before starting to fuel:
    - a. Ensure that boat is moored securely.
    - b. Close all ports, windows, doors and hatches.
    - c. Be sure the proper type and grade of fuel as recommended by your engine manual is used.
    - d. Know the capacity of your fuel tank and how much fuel is currently in the tank before fueling. Determine how much additional fuel is required to avoid overflow.
  4. During fueling:

Keep the fill nozzle in contact with the fuel opening at all times to guard against possible static spark or spill. See Figure I19.



Grounding the fuel hose - Proper

(Nozzle in contact with fuel opening - Correct)



Not grounding the fuel hose - Improper

(Nozzle not in contact with fuel opening - Incorrect)

**Figure I19: Grounding Fuel Hose**



#### **Gasoline**

*Avoid overboard spills. Be alert. The fuel nozzle should automatically shut off when using an automatic shut off nozzle. Be ready in the event it does not or if you are using a different type of nozzle for dispensing fuel. **DO NOT TOP OFF.***



#### **Diesel**

*Avoid overboard spills. When tank is almost full the sound from the fuel fill/vent will change. The pitch will become higher indicating the tank is close to being full. Stop pumping fuel into tank. **DO NOT TOP OFF.***

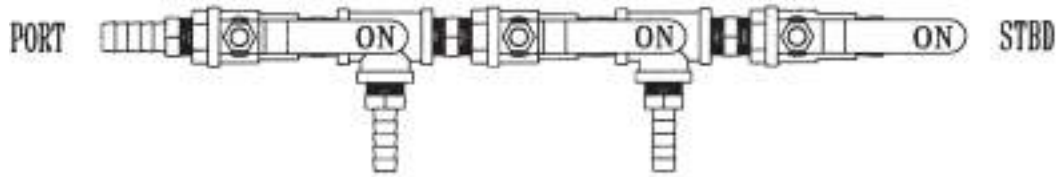
5. After fueling:
  - a. Replace all fill caps securely.
  - b. Wipe up any spilled fuel.
  - c. Open all ports, windows, doors and hatches.
  - e. Determine that there is no odor of fuel in the engine compartment or below decks before starting machinery, turning on lights or lighting stove. Operate the bilge blower system for at least four (4) minutes before engine start-up.
  - f. Be prepared to cast off moorings as soon as engines are started.



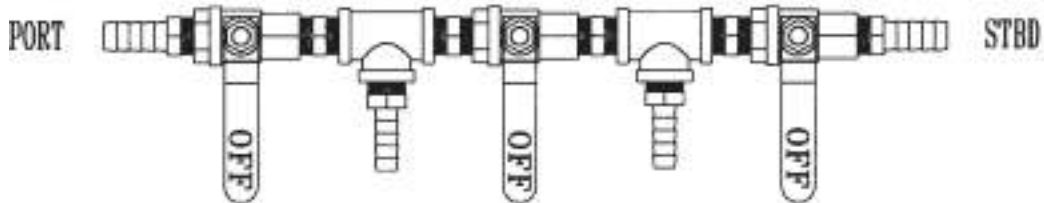


**NOTE: GENERATOR OPTION HAS SEPARATE FUEL PICK-UP.**

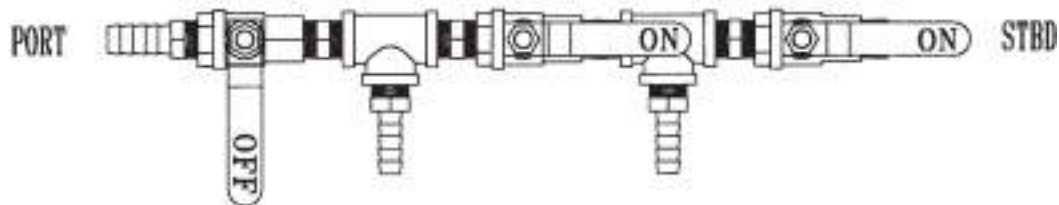
**PORT ENGINE AND STARBOARD ENGINE DRAWING FROM BOTH FUEL TANKS.**



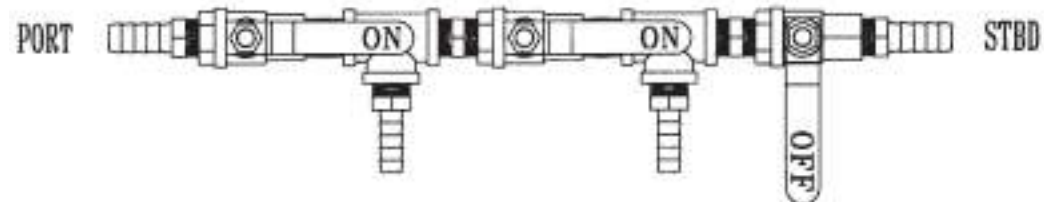
**FUEL SYSTEM COMPLETELY CLOSED.**



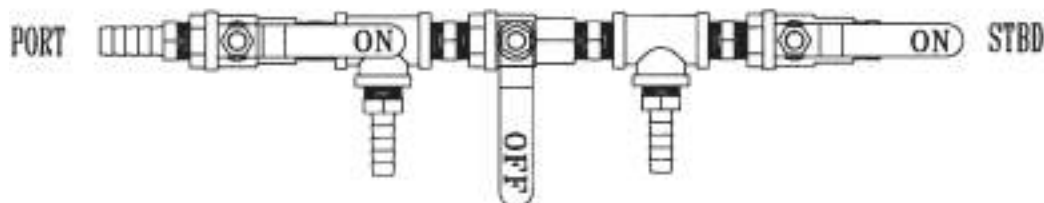
**PORT ENGINE AND STARBOARD ENGINE DRAWING FROM STARBOARD FUEL TANK.**



**PORT ENGINE AND STARBOARD ENGINE DRAWING FROM PORT FUEL TANK.**



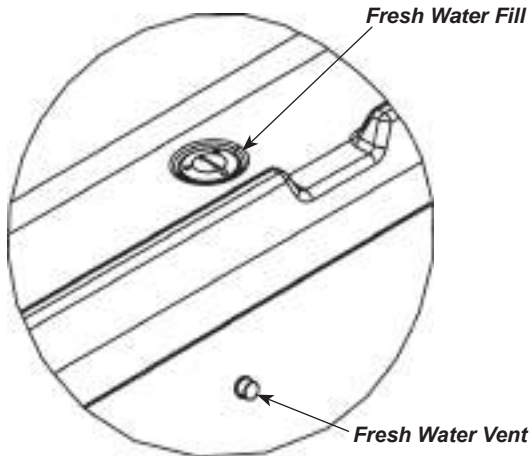
- 1) PORT ENGINE DRAWING FROM PORT FUEL TANK.
- 2) STARBOARD ENGINE DRAWING FROM STARBOARD FUEL TANK.



**Figure I20: Fuel Valve System - Gasoline & Diesel**

## J - 1 GENERAL

All Four Winns V Series models are equipped with a fresh water supply system. This system consists of a water supply tank, water distribution lines and a distribution pump. The water fill deck plate for the fresh water system may be located on the deck and labeled accordingly. Always fill the tank slowly. See Figure J1. Other models have a dockside inlet which is used to fill the fresh water tank. See Figure J2.



**Figure J1: Fresh Water Fill & Vent**  
(Locations may vary depending on model)



**Figure J2: Dockside Inlets**  
(Locations may vary depending on model)

The water tank is equipped with an overboard vent (Figure J1). Maintain a close visual watch on the overboard vent while filling the water tank. Always fill

the tank slowly. When the tank is almost full, water will spurt out of the vent.

**CAUTION**

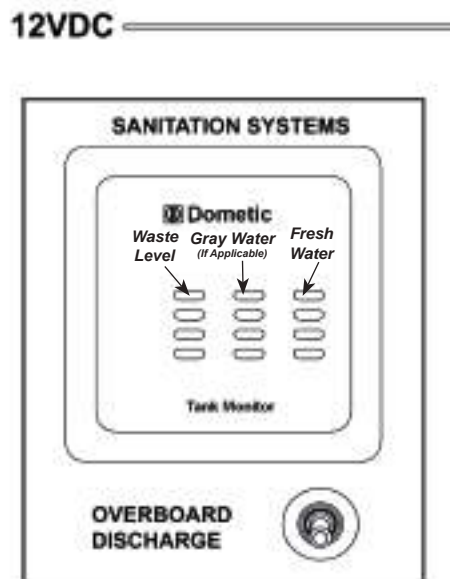
*The water deck plate is appropriately labeled. DO NOT fill the system with anything other than water. Should the system become contaminated with fuel or other toxic solution, component replacement may be necessary.*

**NOTICE**

*When filling the tank, never seal the hose to the deck plate (if applicable). The tank could become pressurized and could rupture.*

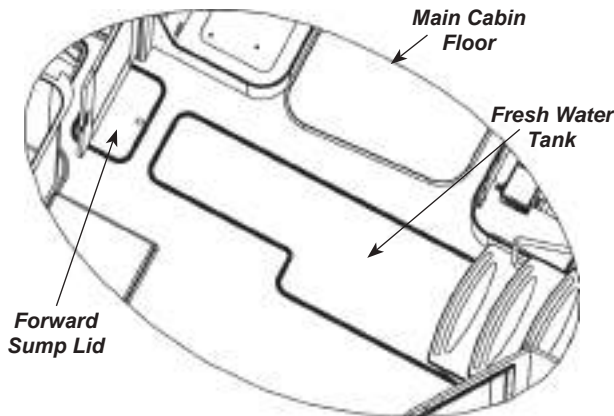
*DO NOT overfill the water tank. Tank damage may result. Water capacity and tank location may vary due to other equipment that may be installed on the boat.*

For the potable water capacity, please refer to our Four Winns website at [www.fourwinns.com](http://www.fourwinns.com). Tank monitoring systems are available certain models. These indicators are located on the 12VDC panel or in the head depending on the model. The systems indicate such things as the water/waste levels. Refer to Figure J3. Included in the owner's packet is the manufacturer's literature regarding the level indicators and their functions. Note: Depending on the number of systems installed will determine the number of indicators the monitor will have.



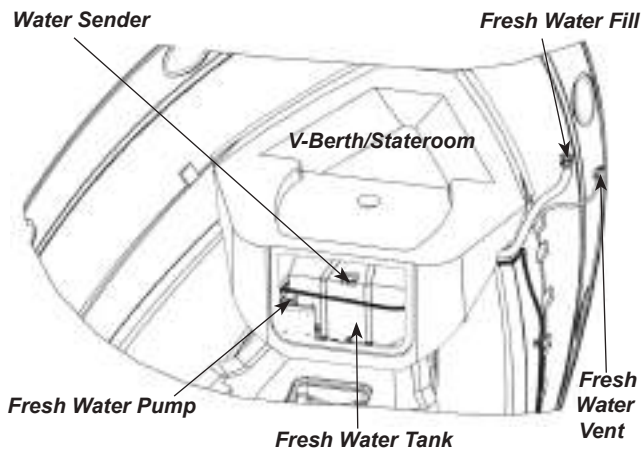
**Figure J3: 12VDC Cabin Panel - Sanitation Systems**  
(Location may vary depending on model)

On certain models, access to the tank is gained through the fresh water lid located in the main cabin's floor. See Figure J4.



**Figure J4: Fresh (Potable) Water Tank Lid Location**  
(Locations may vary depending on model)

Access to the tank is gained through the forward berth's under berth storage drawer on other V series models. See Figure J5.



**Figure J5: Fresh (Potable) Water Tank Location**  
(Locations may vary depending on model)

The materials from which the components of the water system are made may give the water supply a peculiar taste, especially when new. This condition is normal and can be reduced somewhat through the use of a water filter. The taste will completely dissipate in time.

## J - 2 DISINFECTING THE FRESH WATER SYSTEM



*The fresh (potable) water system should be disinfected prior to initial use.*

The water system should be disinfected before first use and at the beginning of each season. The following information is a general guide to disinfecting the fresh water system.

A suggested method of disinfection is taken the American Boat & Yacht Council (ABYC H-23). Perform the following steps in the order indicated:

1. Flush entire system thoroughly by allowing potable water to flow through it.
2. Drain system completely.
3. Fill entire system with a chlorine solution having a strength of at least 100 parts per million, and allow to stand for one (1) hour. Shorter periods will require greater concentrations of chlorine solution. See Table I.
4. Drain chlorine solution from entire system.
5. Flush entire system thoroughly with potable water.
6. Fill system with potable water.

Table I shows how much disinfecting agent is required to make up various quantities of 100 parts per million chlorine solution.

Amount of chlorine compound required for 100 ppm solution.

Solution (Gallons)	Chlorinated Lime 25% (ounces)	High Test Calcium Hypochlorite 70% (ounces)	Liquid Sodium Hypochlorite 1% (quarts)
5	0.3	0.1	0.2
10	0.6	0.2	0.4
15	0.9	0.3	0.6
20	1.2	0.4	0.8
30	1.8	0.6	1.2
50	3.0	1.0	2.0
100	6.0	2.0	4.0

**Table 1 – Chlorine Concentrations**

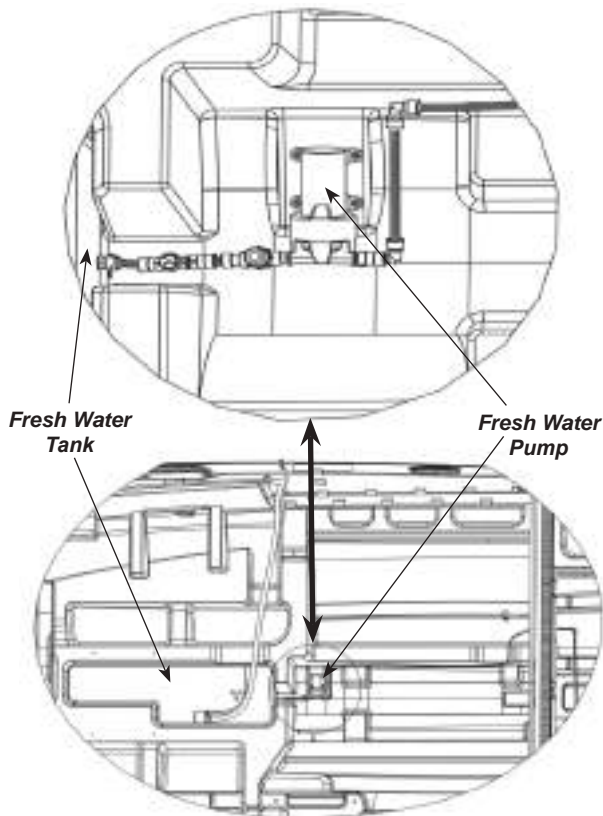
NOTE: This table contains information taken from the Handbook on Sanitation of Vessel Water Points, Public Health Service Publication No. 274 - Reprinted June 1963.

To remove excessive chlorine taste or odor which might remain in the system, prepare a solution of one quart vinegar to five gallons water and allow this solution to agitate in the tank for several days during boating. Then drain tank and refill with fresh water.

All drains are equipped with traps, and the water will drain slowly. If the system is not operating properly, have it checked by your authorized Four Winns dealer.

### J - 3 PRESSURIZED WATER SYSTEM

The water pump is an automatic, on-off, self-priming pump that can service several outlets at once. The pump will build up water pressure and will turn off when it reaches 60 psi. Refer to Figures J5 & J6.



**Figure J6: Fresh Water Pump & Location**  
(Locations may vary depending on model)

#### A. Priming the System

After filling the water tank, open all faucets partially. Depending on the V series model either activate the FRESH WATER circuit breaker switch on the cabin 12VDC cabin panel or the FRESH WATER switch located on the battery switch to supply the system with water. Let the pump run until water comes out of the galley faucet, transom shower, head faucets and showers.

After all the air has been purged from the system and a steady flow of water is coming from each outlet, turn off

the faucets one by one. Begin with the cold water faucets and continue until all faucets are shut off. As the pressure builds, the pump will automatically shut off at approximately 60 psi. Refer to Section H-7 - 12 Volt Electrical Equipment and the manufacturer's literature included in the owner's packet for additional information.

#### B. System Operation

When properly primed and activated, the pressurized water system can be used in the same manner as the water system in a home. An automatic pressure sensor in the water pump keeps the system pressurized. Simply turn on the faucet and water will be delivered. If the system has been recently filled, or has not been used for an extended period of time, air bubbles may accumulate at the pump and/or in the waterlines. If this should happen, re-priming may be necessary. Refer to the preceding subsection regarding priming the system.

To obtain the most consistent mixture of hot and cold water, turn the cold water on full, then mix in hot water until the desired temperature is obtained. If water pump cycling occurs, some minor variations in water temperature can be expected.

Whenever the boat will be left unattended for an extended period, depending upon the model either the FRESH WATER PUMP circuit breaker switch or FRESH WATER switch should be turned to the OFF position. This respective switch should also be turned OFF whenever the water tank is to remain empty for an extended period of time.

#### C. Water Heating Systems

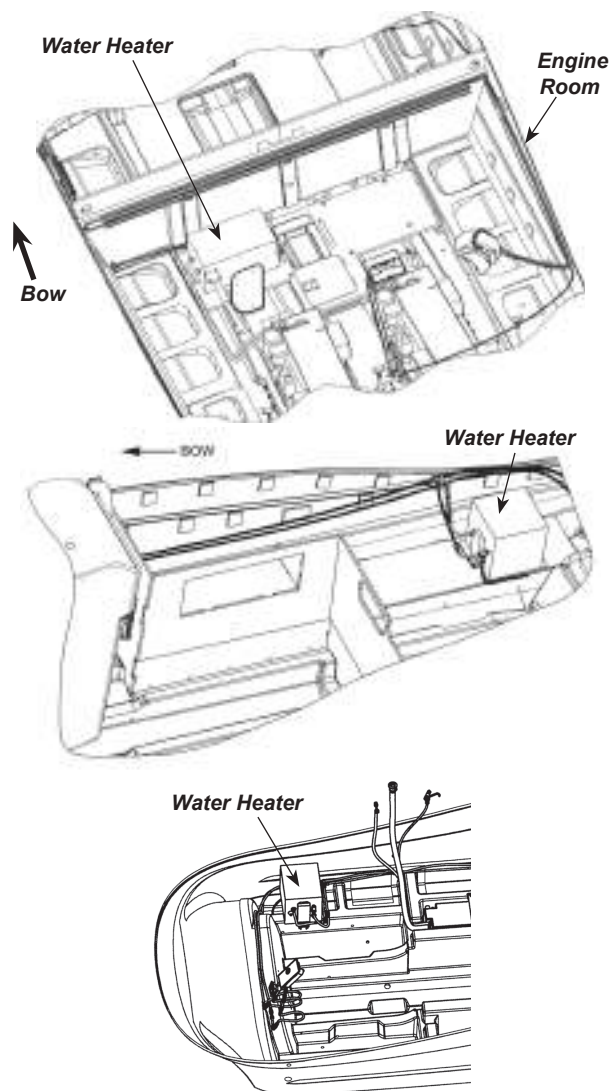
A water heater is available on the V series models. If applicable, the capacity of the water heater may be found on our website at [www.fourwinns.com](http://www.fourwinns.com). Refer to Figure J7 for various locations of the water heater.

#### NOTICE

*Water heater location may vary due to the installation of optional equipment.*

#### NOTICE

*DO NOT supply power to an empty water heater. Damage to the heater will result immediately. The water system must be filled and primed before attempting to use the water heater.*



**Figure J7: Water Heater Locations**  
(Locations may vary depending on model)

If installed, the water heater incorporates a heat exchanger. The heat exchanger allows the engine coolant to quickly heat a portion of the fresh water supply while the engines are operating. This provides hot water at times when AC power is not available. Additional information on heat exchangers is discussed in the hot water heater manufacturer's manual. Please refer to Section H on Electrical Systems for additional information.

#### D. Using the Shower

Turn on the faucets to desired temperature, remove the shower spout from its holder, move the diverter lever on the shower head (if required), and the shower is operational.

On other V series model, turn on the shower by lifting up on the shower handle. Rotate the shower handle position to obtain the desired temperature. The shower head is designed to be hand-held. If desired the shower sprayer may be removed from its holder position and used. This hand-held feature allows for greater ease of use and efficiency. When showering has been completed, turn the shower handle to the off position and place the shower head back onto its holder (if applicable). Note: On certain models the height of the shower holder may be adjusted for convenience.

When using the shower, draw the shower curtain (if applicable) closed before using the shower. Damage to the finish can result if surrounding walls and flooring are allowed to become excessively wet. Thoroughly dry these areas after showering.



*The water temperature can vary during shower use as the pressure pump cycles on and off.*

A shower sump pump(s) is incorporated into the drain system of the shower. The shower drains into the sump(s) located generally forward of the aft cabin. The water will then be pumped overboard. If a gray water system is installed, the water will be pumped into the gray water holding tank.

The sump pump circuitry is protected by circuit breaker(s). Depending on the model, the circuit breaker may be either located on the aft circuit breaker panel and/or the 12VDC cabin panel or the battery switch panel. The sump pump includes an automatic float switch. The sump pump will automatically start as soon as the water in the sump reaches a level that causes the float on the switch to rise. The gray water is then pumped overboard through thru-hull fitting(s) or into the gray water holding tank (if installed).

After showering, let the water flow for a period of time to flush the pump of soap residue. Check the sump for excess residue periodically. When rinsed out, the pump will automatically shut off.

If water flow from the shower head appears to be restricted, it may be due to sediment accumulating at the shower head. If necessary, remove the shower head and clean the discharge holes with a fine wire. Periodically check the sump pump screen for clogs to prevent drainage problems from occurring in the shower drain. Refer to the manufacturer's literature included in the owner's packet.

## J - 4 GRAY WATER SYSTEM

This feature is available on the V series models. If installed, the water from the galley sink, head sink and shower will drain into a sump and is pumped into a gray water holding tank respectively. A waste level indicator may be installed and is located in the head compartment or on the 12VDC cabin panel depending on the model. A pumpout fitting labeled WASTE but designated for gray water is provided on the deck.

### NOTICE

*Certain geographical areas have restrictions on gray water being pumped or drained overboard. Be sure to check all local, state and federal laws in the boating area.*

## J - 5 SHORE WATER CONNECTION

Shore water connection is available on the V series models. This feature allows the direct connection of a city or shoreside water supply to the boat's water system to provide a constant supply of fresh water without the need to constantly refill the fresh water supply tank. This minimizes pressure pump operation thus extending the life span of the pump.

Dockside shore water pressure can vary dramatically. Excess pressure could damage the boat's water system so the shore connection also regulates the water pressure to a maximum of 35 psi. The shore water inlet/regulator fitting is typically located at the transom. Locations may vary depending on the model. See Figures J2, J8 & J9 for examples.



**Figure J8: Dockside Water Inlet**



**Figure J9: Dockside Inlets - Transom Systems Locker**

To use shore water, connect a hose from the shore water faucet to the city water inlet on the boat and turn ON the shore water. The water system of the boat will then be pressurized by city water if the system was previously primed.

The FRESH WATER PUMP circuit breaker switch located on the 12VDC cabin panel or battery switch (depending on model) should be turned OFF when using city water. If the pump is OFF, the pump will not function and the water in the storage tank of the boat will not be utilized.

### NOTICE

**Always** remember to disconnect the shore water supply hose before leaving the dock, otherwise damage to the dockside inlet and/or boat may occur.

**Always** turn off the shore water whenever the boat is left unattended. If a major water leak did occur and went undetected, the boat could fill with water and sink.

**DO NOT** alter or repair the pressurized water system or shore water connection without having proper knowledge of the system. Damage to the water system can occur.

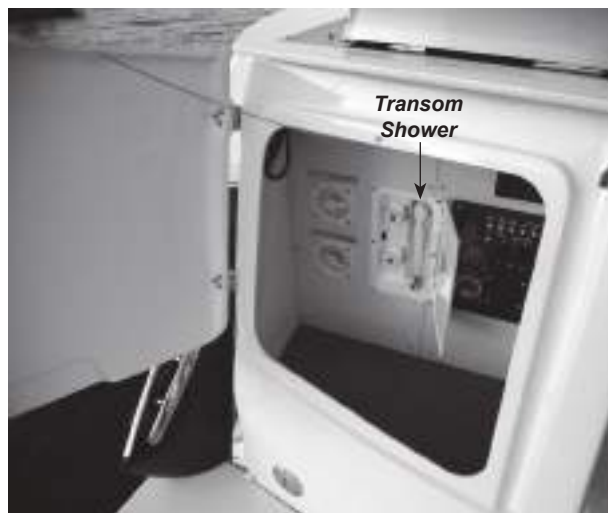
See Section J-1 for general water system information and instructions on filling the water tank. **Note:** The fresh water tank will not be filled while connected to shore/city water.

## J - 6 TRANSOM SHOWER

The transom shower with a choice of hot/cold water is available. The shower unit is located at the transom. Refer to Figures J10 & J11. Note: Certain V series models may also have available a bow washdown.



**Figure J10: Transom Shower**  
(Representative View Only - Models may vary)



**Figure J11: Transom Shower Location**  
(Locations vary by model)

The water supply system can be used for showering or washing down the transom area. As long as there is water pressure, the shower sprayer will operate. Fresh water tank capacity is limited. Connect the boat to shore water before using large amounts of water as required when washing down the transom/swim platform area.

## J - 7 WASTE SYSTEMS

### NOTICE

The various anti-pollution laws presently in effect have necessitated the use and availability of a wide variety of toilets. They have been chosen to provide proper fit, reasonable longevity and reliable service, at a realistic cost.

Certain toilets obtain their flush water from the fresh water system. Fresh water is the key to an odor free bathroom compartment. This system eliminates the unpleasant sulfide odors which plague saltwater systems. Flush water is no longer drawn through the through-hull fittings, seacock, and vented loop. It also extends the life of the system components by eliminating salt water and impurities from accumulating in the system over time.

The toilets are optimized for minimal water use. **Note:** The fresh water system is protected from any possible contamination from the waste system. Lock-out electronics is another notable feature which prevents flushing if the waste holding tank is full and may be available on your particular model. A circuit breaker which protects the toilet circuit is located on the 12VDC cabin panel or DC breaker panel at the helm and is labeled accordingly.

The following are basic manufacturer's toilet operations for the various model toilets. Be sure to consult the toilet manufacturer's owner's manual for complete details regarding the toilet operations as well as maintenance.

### A. Porcelain Head

Certain V series models comes with a porcelain head and holding tank. For the holding capacity, please refer to our Four Winns website at [www.fourwinns.com](http://www.fourwinns.com). The toilet is a left hand, manually-operated toilet and is surprisingly easy to operate. The toilet obtains water from the fresh water tank for rinsing the bowl. See Figures J12 - J14.

To operate toilet:

1. Move the wet/dry selector to the WET bowl position (left) and pump handle up and down a few times to add some water to the bowl prior to use.

2. After using, flush again by pumping the handle up and down (in WET bowl position) until bowl is thoroughly rinsed and evacuated.
3. Then move the wet/dry bowl selector to the DRY bowl position (right) and continue pumping until only about one cup of water remains in the bottom of the bowl.
4. Leave the wet/dry bowl selector in the dry bowl position when not in use.



Figure J12: Wet/Dry Toilet Operations Label

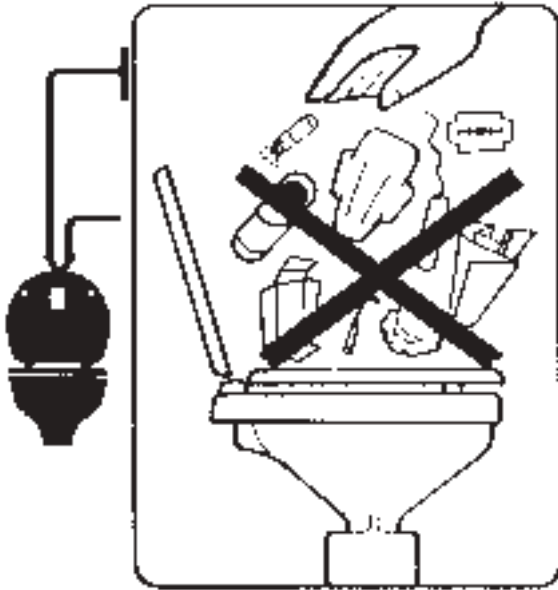


Figure J13: Do Not Place These Items in Toilet Label

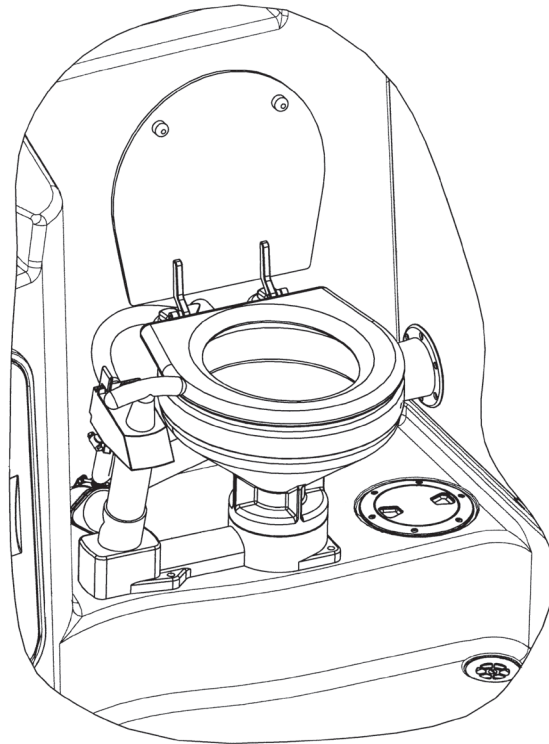


Figure J14: Porcelain Toilet - Left Hand

## B. Electric Toilet Operations

1. Add water to the toilet bowl by pressing “Add Water” switch (1) and hold until desired water level is achieved. See Figure J15. (Do not press “Add Water” switch too long or overflow may occur.) More water is usually added only when flushing solids.
2. To flush the toilet press the “Flush” switch (2) down and hold for a few seconds after waste drains from toilet bowl (about five seconds). See Figure J15. This switch activates a powerful macerator pump that siphons water and waste from the bowl, macerates, and propels the effluent through the discharge line/holding tank. To use less water for liquid-only flushes, press “Flush” switch for shorter period of time.
3. “DRY BOWL” OPERATION - During periods of rough travel, water in a toilet bowl can splash out and into the bathroom area. To avoid this situation, press “Dry Bowl” switch (3) to drain water completely from toilet bowl. See Figure J15. Water is not added to bowl during or after pressing the “Dry Bowl” switch





Figure J15: Electric Toilet Switch



*Do Not Flush Waste with “Dry Bowl” Switch! To maintain proper cleanliness and operation of the toilet and macerator pump, water should be used with every flush.*



*Do Not Flush Foreign Objects! Flush only water, bodily wastes and rapid-dissolving toilet tissue. Do not flush wet wipes, sanitary napkins, condoms, diapers, paper cups, cotton swabs, food, hair or liquids such as oils or solvents as clogging or damage to the toilet or toilet system may occur.*

## C. VacuFlush® Sanitation System

The VacuFlush® sanitation system is available on certain models. The system eliminates the unpleasant sulfide odors which plague saltwater systems. Flush water is no longer drawn through the through-hull fittings, seacock, and vented loop. It also extends the life of the system components by eliminating salt water and impurities from accumulating in the system over time.

The VacuFlush® toilet operates in a different way from other marine toilets. VacuFlush® systems use a small amount of water (a little more than a pint) per flush in addition to a simple vacuum. The toilet is connected to the fresh water system. Fresh water is the key to an odor free bathroom compartment. VacuFlush® toilets are equipped with an integrated vacuum breaker which prevents the possible contamination of the potable/fresh water supply. See Figures J16 & J17. Also refer to the manufacturer’s literature included in the owner’s packet.

### NOTICE

*The VacuFlush® (TOILET) switch located in the head must be ON in order for the toilet to flush & recharge.*

To operate:

1. To add water to the toilet before using, raise flush lever until desired water level is reached. Generally, more water is required only when flushing solids. See Figure J16.
2. To flush toilet, press flush lever sharply down to the floor until contents clear bowl. A sharp popping noise is normal when the vacuum seal is broken and the flushing action begins. **Be sure to hold lever down for 3 seconds.** If flush lever is accidentally released before waste clears bowl, do not attempt to flush toilet again until vacuum pump stops running. A small amount of water should remain in the bowl after flushing.
3. Do not dispose of sanitary napkins or other non-dissolving items in toilet, such as facial tissue or paper towels. These items can cause plugging of the system. Refer to the “Deodorants and Special Tissue” section in the manufacturer’s manual for more information.

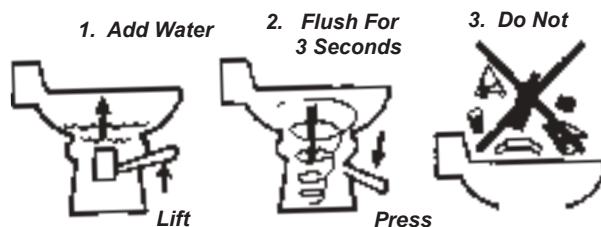
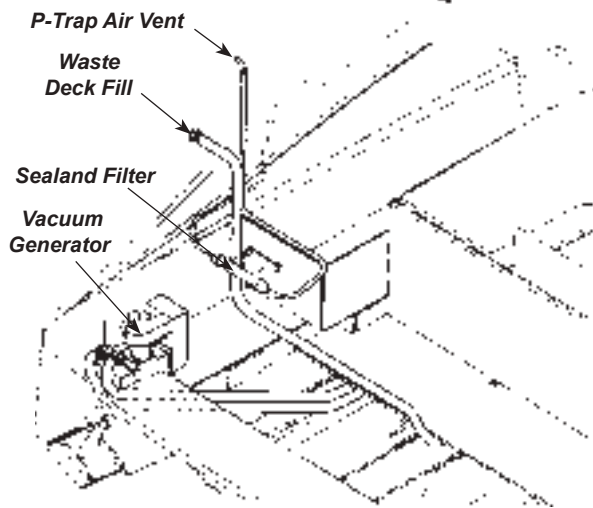


Figure J16: VacuFlush® Operations

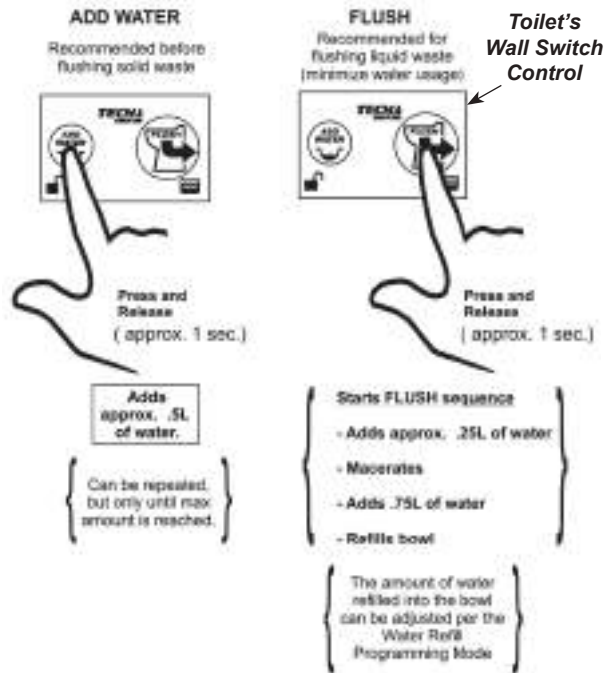


**Figure J17: VacuFlush® Vacuum Generator and Waste Deck Fill - (Representative View Only - Location may vary depending on model).**

#### D. Tecma® Sanitation System

The toilet's wall switch control has two primary functions. See Figure J18.

- 1) An ADD WATER button – Adds approximately 0.5L of water each time it is pushed momentarily. Electronics prevent overflow.
- 2) A FLUSH button – Starts an add water and macerate sequence that runs the motor and adds water twice for maximum cleansing and minimum water usage. Sequence ends with a small amount of water added to the bowl to provide an odor trap. Recommended to minimize water use and for liquid waste disposal without adding water.



**Figure J18: Tecma® Toilet Operations (Representative View Only - Models may vary)**

**CAUTION**

*If toilet is connected to any through-hull fittings, always CLOSE or TURN OFF all seacocks when boat is unattended – even if only for a minimal time.*

**CAUTION**

*For units using fresh water that are (at any time) connected to shoreside municipal water supply systems, Shoreside system must be DISCONNECTED if boat is left unattended – even if only for a minimal time.*

**CAUTION**

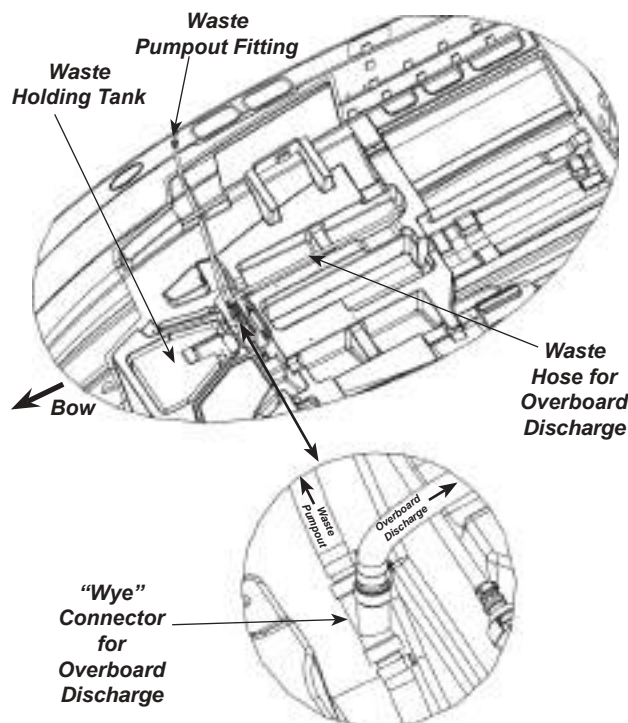
*Only human waste and toilet paper should be put into the toilet. Never flush FOREIGN MATERIALS (e.g. paper towels, pre-moistened wipes, condoms, feminine hygiene products, dental floss, household garbage, etc.). Damage to toilet and/or waste system may result.*

**NOTICE**

*It is important to use a RV/Marine tissue that disintegrates rapidly, which household tissues cannot be relied upon to do.*

## E. Head With Overboard Discharge

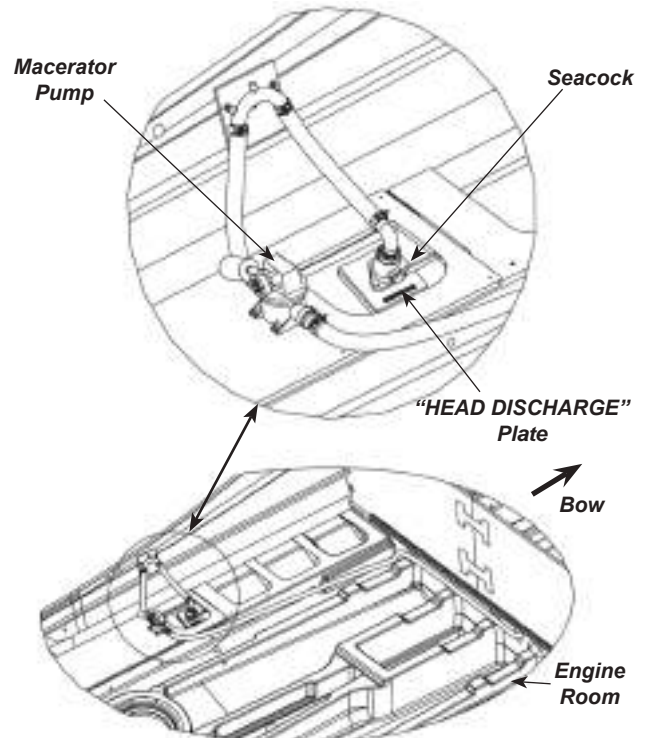
This equipment is available on certain V series models. The head toilet operations are the same as the systems described earlier. A single “wye” connector is incorporated into the waste holding tank system. See figure J19. An additional hose with a seacock and discharge pump has also been installed for overboard discharge. Refer to Figure J20. **Note:** A circuit breaker which protects the discharge pump’s circuitry is located on the 12VDC cabin panel or the DC breaker panel.



**Figure J19: “Wye” Connector - Overboard Discharge**  
(Representative View Only - Models may vary)

### NOTICE

The discharge pump must be used to discharge waste overboard. DO NOT use the discharge pump to discharge waste at a pumping station.



**Figure J20: Seacock & Macerator Pump - Overboard Discharge**  
(Representative View Only - Models may vary)



### HAZARD OF FLOODING

Close all waste system seacocks when toilet is not in use. Failure to do so may result in flooding which can cause loss of property and life.

To operate the overboard discharge system:

1. The seacock (discharge valve) is located in the engine compartment labeled HEAD DISCHARGE. To open, turn the valve so that the handle is parallel to the flow of the valve. **Note:** The seacock may be fitted with a device called an “Interlock Switch” which prevents the overboard discharge switch from activating the discharge pump should the seacock be in the CLOSED position. See Figure J21. Should the pump not activate please check to see that the seacock is in the OPEN position. Additionally, the waste deck plate cover must be tightened securely for the overboard discharge system to operate properly.

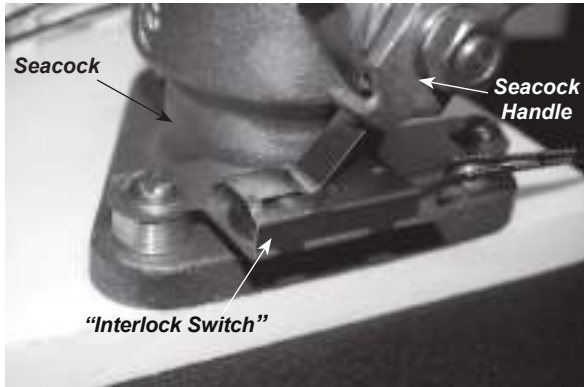


Figure J21: "Interlock Switch" Attached to Seacock

- Turn ON the overboard discharge switch (if applicable) which is located on the 12VDC cabin panel. See Figure J22. Allow the discharge pump to run until the storage tank is empty. The sound of the pump's motor load and speed will change when the tank becomes empty.

## 12VDC

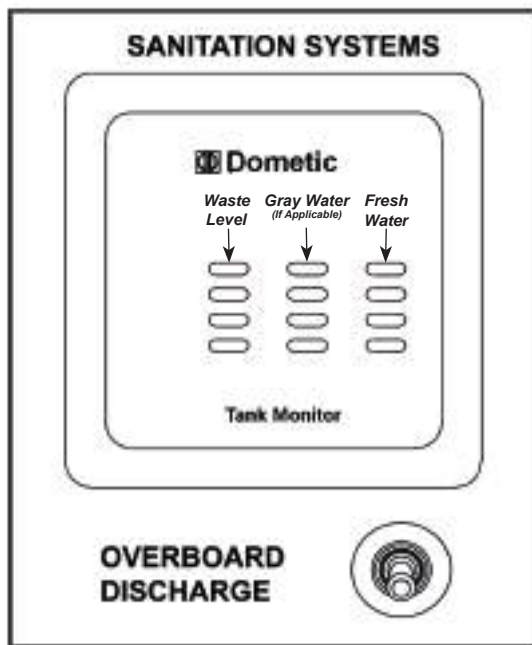


Figure J22: Overboard Discharge Switch

- Turn the overboard discharge switch OFF.
- Turn the head discharge valve handle to the closed position, and secure it. This thru-hull valve (seacock) **must** be closed to prevent water from being forced back into the system.

### NOTICE

Discharging waste overboard is illegal in most US waters today. Discharge is limited to certain coastal waters, a designated distance offshore. Check with your local boating regulations before proceeding with any discharge activities.

Some local regulations require overboard discharge systems be physically secured in a closed position during use of the boat in waters designated as "no discharge" areas. Check with local boating regulations. Refer to the manufacturer's literature for additional information.

### F. Dockside Waste Pump Out

On the V Series models waste pump out capability is available. Waste can be removed from the holding tank by taking the boat to a dockside waste pumping station. Most marina fueling facilities provide such services.

The waste holding tank should be emptied when the waste level indicator reads full. The waste level indicator (if installed) is located on the 12VDC cabin panel or in the head depending on the model. See Figure J22. **DO NOT ALLOW THE WASTE TANK TO BECOME OVERFILLED.**

To pump out the holding tank:

- Be sure the head has some water in the bowl.
- Connect the dockside pump out connection to the WASTE plate located on the deck. See Figure J23.

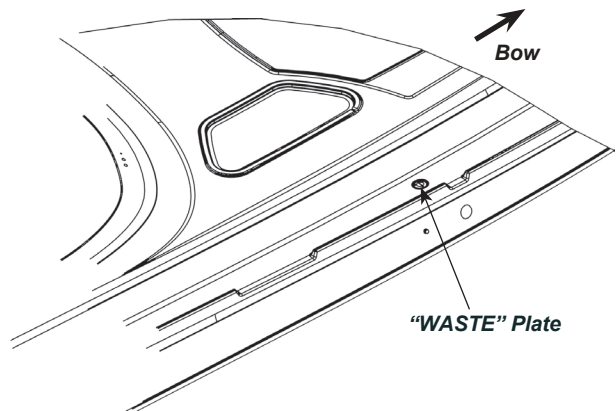


Figure J23: Waste Pumpout Fitting Location (Representative View Only - Locations may vary by model)

**NOTICE**

*Usually the dockside pump out connection will screw into the waste deck plate or has a rubber sleeve that inserts into the plate and must be held in position during the pump out operation. If the hose is not air tight or connected properly, waste could spurt out or leak around the deck fitting and into the boat.*

3. Have the pumping station operator activate the pumping equipment. The waste will be drawn from the holding tank and into the pumping station's disposal tank.
4. Remove the pump out connection from the deck plate. Add at least 5 gallons of clean water to the holding tank on most models through the waste deck fitting using a dockside water hose.
5. Repeat steps 2 & 3 above to pump out the water used in step 4 to flush the holding tank.
6. Add waste holding tank treatment chemical to the head bowl. It is available from the dockside pumping station or can be obtained from your dealer. Flush at least twice.



*Be careful when handling and storing treatment chemicals. Not only are they toxic, but they will also stain and damage surrounding surface.*

**J - 8 SYSTEM MAINTENANCE**

Information supplied with water and waste system components by the equipment manufacturers is included with this manual. Refer to this literature for additional operation and service information.

Be sure the batteries in the boat are properly charged. Operating the pressure pump from a battery with a low charge will result in pump cycling. This could lead to premature pump failure.



*The decomposition of waste produces a colorless, odorless gas, methane, that is lighter than air, combustible, and extremely lethal. Always provide sufficient ventilation when effecting repairs to the waste system and allow no odor from the waste system to go unresolved.*

**A. Clean Vents and Screens**

Periodically, inspect the water tank vents and thru-hull vent fittings for any dirt, wax, etc. Carefully remove any obstruction with a pipe cleaner or similar device. **Be sure not to puncture the screen.** The stainless steel vent cap is not removable.

**NOTICE**

*Failure to keep the water tank vent fittings clean will cause excessive pressure buildup within the tank during filling. This can cause water tank damage.*

Periodically remove the filter screens from the faucet discharge spouts and shower head. Remove the accumulation of sediment from the screens. If necessary, clean out the holes using a fine wire. A buildup of debris in the faucet filter screens can create enough restriction to cause the pump to cycle on and off.

Check the in-line water filter/screen for sediment and blockage. It is located between the water tank and the pressure water pump. If obstructed, remove from the water line and either clean or replace the part. The filter unit will twist apart.

Inspect and clean the shower sump every 30 days. Some water will always be in the compartment. Sediment and other debris will buildup and affect the automatic bilge switch and pump operation. Remove the pump's cover and clean the screen. The screen will become blocked and the pump will not operate properly. To clean the compartment, use baking soda and a fine wire brush to remove dirt and other debris. This will also serve to disinfect the area.

**B. Winterizing the Water System**

Winter lay-up service procedures should include a thorough draining of the water system. Disconnect all accessible fittings. Blow out all lines. Be sure the hot water heater, fresh and gray water tanks, transom shower, pumps and lines are completely dry. Leave

all faucets open. Freezing water can cause severe damage to all water system components.

#### NOTICE

*Always winterize the fresh water system prior to winterization of the hull drainage (bilge pump) system.*

Draining the system as mentioned can be very tedious and an incomplete job can result in expensive repairs. The use of nontoxic antifreeze (such as RV antifreeze) designed for fresh water systems considerably reduces the work necessary and is a more positive means of winterizing the system. Follow the directions included with the antifreeze solution.

To winterize:

1. Turn on the water pump and drain the water tank by opening a faucet (the pump will run faster when it is empty).

#### NOTICE

*Be sure the circuit breaker for the water heater in 120 Volt AC panel is in the OFF position. The water heater will be damaged immediately by supplying electrical power to an empty water heater.*

*DO NOT run the water pump without water in the system. Pump damage will result. Be watchful and turn the pump off as soon as the tank becomes empty.*

2. Add 15 gallons of RV antifreeze to the water tank.

#### NOTICE

*Generally the hot water heater will require approximately five gallons of antifreeze before the hot water lines will have antifreeze running through them. The cold water faucet should be turned OFF at some point to test for antifreeze in the hot water line.*

3. Turn ON all faucets (both hot and cold) until undiluted antifreeze is seen. Make sure the transom shower, head faucet and galley faucet have antifreeze coming out.

4. Activate the shower sump pump and pour approximately 1 quart of nontoxic antifreeze down the shower drain. The shower sump will discharge some of the antifreeze overboard.



*Use only nontoxic antifreeze solutions such as RV antifreeze. DO NOT use ethylene glycol solutions; the type that is used in engine coolant systems. These are toxic.*

#### NOTICE

*Be sure to wipe up any antifreeze that has been spilled on the fiberglass shower surfaces.*

### C. Winterizing the Waste System

To winterize the waste holding tank, flush the tank with soap, water and a deodorizer (e.g., Lysol Liquid™). Empty the tank and pour two (2) gallons (3 gallons if equipped with overboard discharge) of RV antifreeze into the bowl and flush.

If the boat is equipped with overboard discharge capabilities, follow the normal procedures above. Run the discharge pump only long enough until the antifreeze solution is being pumped overboard.

For additional information, refer to the manufacturer's manuals in the owner's packet.

#### NOTICE

*The instructions listed in this section provide a working knowledge to winterize the water and waste systems. However, to prevent possible damage to components in your boat, Four Winns recommends having the boat winterized by your Four Winns dealer.*

**NOTICE**

*V series layouts and content do vary based on model size, standards and options available. Equipment and its location may vary. Equipment availability is subject to change without notice.*

**NOTICE**

*A gas vapor detector is a monitor which will alert the operator of an accumulation of gasoline fumes in the engine compartment. Available on certain V series models. If equipped, DO NOT rely solely on detectors or similar equipment. ALWAYS conduct a physical inspection of the engine compartment.*

**K - 1 ENGINE COMPARTMENT VENTILATION**

All Four Winns V series models are equipped with engine compartment ventilation. This system is designed to meet or exceed the requirements (in effect at the time of manufacture) of the U.S. Coast Guard, the National Marine Manufacturers Association, and the American Boat and Yacht Council.

**A. Natural Ventilation System**

This system includes air intake and exhaust components. The air and exhaust ducts reach to the lower bilge area. This provides adequate air movement while underway and during bilge blower operation.

**B. Forced Air Ventilation**

All Four Winns V series models are equipped with an electric bilge blower. The bilge blower provides the ventilation required prior to starting the engines and while at idle. See Section H - Electrical Systems for blower operation instructions.



*Before starting the engine(s) or generator, operate the engine compartment bilge blower for four (4) minutes. Then check the engine compartment for gasoline vapors. ALWAYS operate the bilge blower while the engines are at idle or the generator is in use. Failure to comply could cause explosion and thereby inflict serious injury or death.*



*Fumes can come from batteries while charging. A concentration of hydrogen fumes can be explosive under the right conditions. Ensure to follow the above warning.*

**C. Engine Ventilation System Maintenance**

Periodic inspection and cleaning of the ventilation ducts is necessary to ensure adequate air circulation. A buildup of leaves, twigs, or other debris can severely reduce ventilation. Be sure bilge water does not accumulate to a level that would obstruct the ventilation ducts.

Blower operation can be tested by placing a hand over the vents. DO NOT rely on the sound of the blower. Be sure a substantial amount of air is being exhausted by the bilge blower. Check the bilge blower system often, preferably before each cruise.

**K - 2 CABIN VENTILATION**

The V series cabins are equipped with deck hatch(es) for ventilation. Certain aft cabin window opens to provide ventilation. The cabin's side window(s) (portlight) on certain V series models may be opened to provide additional ventilation.



*Failure to properly ventilate the boat while the engines or generator are operating may permit carbon monoxide to accumulate inside of the cabin. Refer to Section B-2 - Carbon Monoxide and Section E-2 - Engine Exhaust for additional information.*

Screens and blinds for the forward deck hatch(es) are available on certain V series models. If equipped, this "layered" deck hatch system allows the screens and blinds to be slid to the desired position with ease. Also, storage for the screens and blinds are built into the screen/sun/shade system. See Figure K1.



**Figure K1: Layered Deck Hatch Screen/Sun/Shade System**

#### NOTICE

*Be sure deck hatch(es) is secured while underway. Damage to the hatch may result if left unsecured.*

## K - 3 HULL DRAINAGE SYSTEMS

### A. Transom Drain

A transom drain with plug is provided in the engine compartment to allow water drainage. When boat is out of the water, the boat and cradle should be positioned so any bilge water accumulation during dry storage will flow towards the transom.



*Be sure the drain plug is securely in place prior to launching the boat. Upon shipment of the boat, the drain plug is usually taped to the steering wheel.*

### B. Bilge Pumps

Forward and aft bilge pumps are provided in the bottom of the hull to remove miscellaneous water accumulations that might occur during normal boating or weather conditions. The aft bilge pump is controlled by the BILGE PUMP switch located on the helm

switch panel. Refer to Section H for further information regarding bilge pumps.

The bilge pumps are equipped with an automatic switch to control pump operation. As the water level rises, the automatic float switch will activate the pump. Separate circuit breakers are provided on the battery switch to supply power directly from the "SHIP SYSTEMS" battery to the forward and aft bilge pumps regardless of battery selector switch position.

#### NOTICE

*While at rest, any bilge water accumulation may flow forward. DO NOT allow bilge water to accumulate. Damage to the engine or other components may result. Periodically operate the bilge pump to remove bilge water accumulation.*

When leaving the boat unattended for long periods of time or during excessive rain storms, it is a good idea to check on the boat for excessive water accumulation. Be sure the bilge pumps and automatic float switches are operating properly. The operating time of the bilge pumps will be limited to the battery capacity.

Periodically, clean the bilge pump strainers. DO NOT allow dirt and debris to clog the bilge pump intakes. Check operation of the bilge pump float switch often to ensure movement of the switch is not restricted by debris, portions of the hull, etc.

Wipe up any oil accumulation in the bilge prior to activation of the bilge pumps. Pumping oil overboard will pollute the water, and is subject to fine.

After winterization of the fresh water systems, be sure the bilge area, bilge pumps and associated hoses are thoroughly dry. Damage to the hull, bilge pumps and other equipment could occur if water is allowed to freeze in the bilge. Refer to the manufacturers literature included in the owner's packet for additional information.

### C. Sump

A sump box is typically installed in the floor, just forward of the aft cabin. It is equipped with an automatic float switch and will pump water overboard or into the gray water tank (if available). Refer to Section J-3D on using the shower and for additional information on sump pump operation.



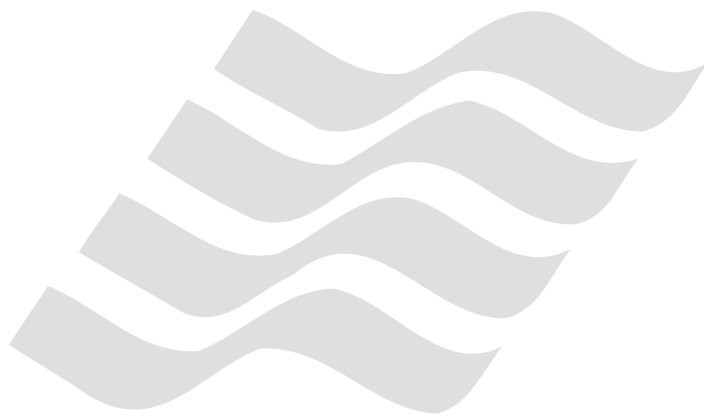
#### **D. Bilge Compartment Drainage**

Certain bulkhead areas of Four Winns® boats are sealed in accordance with U.S. Coast Guard regulations effective at the date of manufacture. Drainage is provided and water can be removed with the bilge pump.

#### **E. Cockpit Drainage**

The V series models incorporate a fiberglass self-bailing cockpit. This feature minimizes water entry to the bilge or engine compartment areas by providing means for water to be drained overboard.

Periodically open all engine hatches and clean the aft bilge compartment. Be sure the drains, tubes and fittings are clean and free of leaves, dirt, or other debris.



**L - 1 GALLEY EQUIPMENT**
**NOTICE**

*V series layouts and content do vary based on model size, standards and options available. Equipment availability is subject to change without notice.*

**A. Electric Cooktop or Stove**

Depending on the V series model in question either an electric cooktop or electric stove is available. The stove may consist of a single or dual burner. Also available is an alcohol/electric stove. See Figure L1 for an example of the stove and other component locations. A circuit breaker marked either RANGE or COOKTOP is provided on the AC cabin electrical panel. Refer to the Section H of this manual and the manufacturer's literature included in the owner's packet for operation, safety procedures and care of the unit.



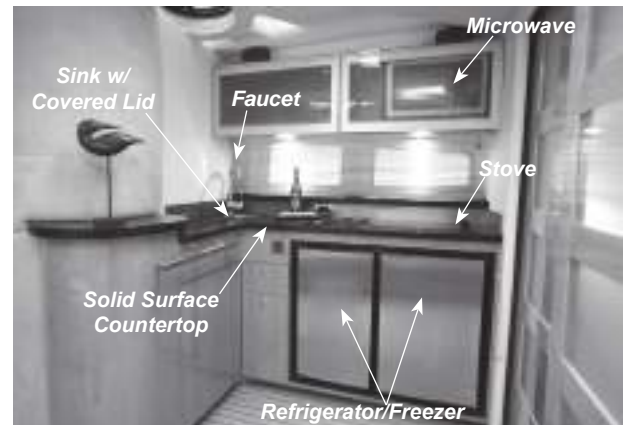
*Care must be exercised while around stoves/cooktops and other appliances. Keep children away from burner(s).*

**B. Microwave Oven**

A microwave is available on the V series models. The circuit breaker on the AC cabin electrical panel must be activated and the boat must be connected to dockside power or utilize the generator (if equipped) in order to operate the microwave. Refer to the manufacturer's literature provided in the owner's packet for information regarding operation, safety & maintenance.



*Do not restrict air flow while microwave is in use, or damage to microwave oven or cabinet may result.*



**Figure L1: Galley**  
(Representative View - Model Layouts vary)

**C. Refrigerator**

A cabin refrigerator is available on most V series models. The refrigerator is designed to operate efficiently on AC shore power or battery power (12 volt). The refrigerator will automatically transfer to 12 volt operation when dockside power is not available and the 12 volt refrigerator breaker is on. In addition to a cabin refrigerator a freezer may also be available as shown in Figure L1.

Generally most refrigerator models have a thermostat that will maintain the temperature desired. To select the temperature turn the thermostat dial to the various numbered positions. The refrigerator may be turned off by turning the thermostat to the "OFF" position. See the manufacturer's literature included in the owner's packet for specific information on the model used in your V series (if equipped).

Care should be exercised while operating the refrigerator on the 12 volt system. The refrigerator requires a substantial amount of current. Excessive current draw can severely drain a battery through extended use.

On certain models a magnetic strip is used inside the seal of the refrigerators. The magnetic strip allows the seal to draw tight to the inside of the refrigerator when the door is closed. Also, make sure retaining latch (if equipped) is in place to secure refrigerator door while underway.

## L - 2 CABIN EQUIPMENT

### A. Dinette Table

A dinette is available on most models and is located in the V-berth or salon area. Table bases are “flush” mounted for convenience and safety. On certain models, the cabin may be converted from a dining area to a berthing space by using the dinette table or support board (if applicable), short table leg(s) and fill-in cushions.

On other V series models, to convert couch to a berth requires the removal of the dinette table and table legs completely. Rotating the leg while lifting will ease the removal. Note: The table leg(s) are removable for most models. Depending on the model, table and leg storage is provided underneath the forward berth mattress. See Figures L2, L3 & L4.



**Figure L2: Dinette Table**  
(Representative View - Models vary)



**Figure L3: Couch Converted to Berth**  
(Representative View - Models vary)



**Figure L4: Dinette Table Storage**  
(Representative View - Models vary)

### B. Carbon Monoxide Detectors

Four Winns has installed a CO detector(s) in the berthing spaces. See Figure L5. This piece of safety equipment could mean the difference between life and death. Check monitor and maintain in accordance with the manufacturer’s instructions. Refer to Section B-2 - Carbon Monoxide for additional information.



**Figure L5: Carbon Monoxide (CO) Detector**  
(Representative View - Models may vary)

## L - 3 ENTERTAINMENT

### NOTICE

Depending on model, the entertainment system installed may be quite complex. Be sure to read all manufacturer’s documentation included in the owner’s packet. Please contact your Four Winns dealer should you have any questions.

## A. Stereo System

On most V series models, an AM/FM stereo with Bluetooth® connectivity is available. Ipod®/MP3 player ports are located typically at the helm and in the cabin on most V series models. This feature allows a person to play his or her music over the boat's sound system. A stereo remote with display feature at the helm is available as well as a stereo remote with display feature at the transom may also be available. An amplifier, tweeters, and a subwoofer may also be available depending on the model. For stereo operation, please refer to the manufacturer's manual included in the owner's information packet.

Speakers are installed within the interior cabin and exterior cockpit areas to provide excellent sound quality. In addition, the cabin and cockpit speakers can be faded in or out depending on the effect desired.

## B. TV and DVD Player

A flat screen TV and DVD player with remote is available on most models. Depending on the V series model, the TV may or may not be wired into the stereo speaker system. If it is not wired into the available stereo system, the TV uses an internal speaker only. Please read the manufacturer's information on the TV and DVD player in the owner's packet for operation and care instructions. See Figure L6.

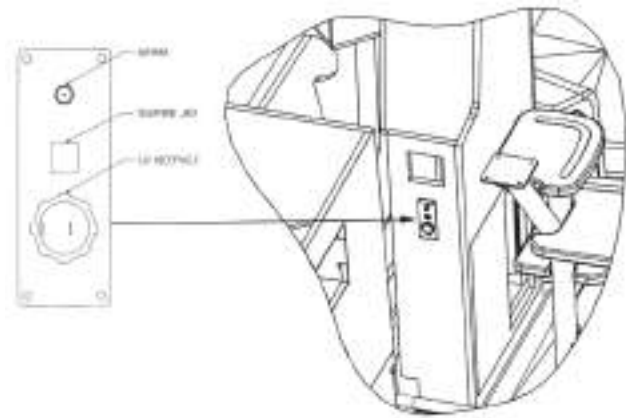
*Flat Screen Television*



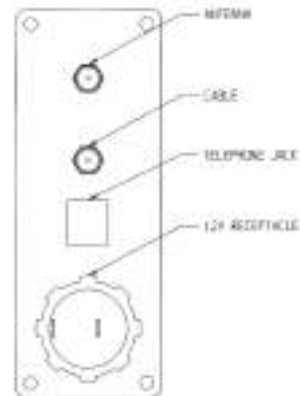
**Figure L6: Television**  
(Representative View - TV's location and TV model may vary)

A dockside phone/cable TV inlet may be installed on the certain V series models. If installed, the telephone/cable TV dockside inlet is typically located in the transom systems locker. TV/phone and TV/cable/

phone panel assemblies are installed inside the living quarters at various location(s). See Figures L7 and L8.



**Figure L7: TV/Phone Panel Assembly**  
(Representative View - Models vary)



**Figure L8: TV/Cable/Phone Panel Assembly**  
(Representative View - Models vary)

## L - 4 AIR CONDITIONING

Air conditioner/heater provides either cooling or heating and is an available feature. The unit operates on available AC power. The output of the air conditioner may be found on our website at [www.fourwinns.com](http://www.fourwinns.com). Be sure the appropriate shore power cord is connected or the generator (if equipped) is running whenever the air conditioning is to be used.

The air conditioning breakers must be turned on to activate the air conditioning unit. These breakers may be located at the dockside power inlet panel and at the AC/DC panel. Depending upon humidity, the air conditioner will condense 5 to 15 gallons of water a day and this water drains into the sump pump which is then pumped overboard.

Air conditioner vents are located throughout the cabin to provide good air circulation. There is a vent in the head for additional air circulation on most models. The vents are adjustable to change air flow direction and can be closed.

The location of the air conditioner may vary by model, floor plan and optional equipment installed. Please contact your Four Winns dealer should you have any questions.

The seawater inlet valve (seacock) is identified with a plate inscribed with the words "Air Conditioner Seawater". Access to the seacock is gained through an access lid in the aft/mid cabin or engine room depending on the model.

#### **NOTICE**

*In order to use the air conditioner, you must first open the seawater inlet valve - seacock (handle parallel to the flow of valve). When not using the air conditioner be sure to close the valve/ seacock.*

#### **NOTICE**

*Most air conditioners utilize surface water as the cooling medium. Prior to using the air conditioning, the boat must be in the water and the seacock to the air conditioning water intake must be in the open position. The air conditioning seacock for water intake may be located in aft cabin under the access lids panel or in engine compartment. Operating air conditioners without proper cooling water will cause damage to the air conditioning system.*

Air conditioners utilized in Four Winns® V series models are equipped with reverse cycle heat. Thus, some heat effect can be derived from the unit. It must be noted that the amount of heat that can be obtained is limited by the temperature of the raw cooling water pumped through the system. When the water temperature drops to 40 degrees Fahrenheit, the output is about 50% of the maximum. At 36 degrees Fahrenheit, the output is very low.

#### **NOTICE**

*During cold conditions, an alternate or supplemental heating system should be used.*

Clean the sea water strainer often. Also, clean the return air filter screens, typically located behind the louvered doors and grills, at least once a month.

Please read the manufacturer's information included in the owner's packet regarding operating instructions, care and maintenance; paying particular attention to winterization.

#### **NOTICE**

*Four Winns continually strives to improve its products. Unit specifications, including standard and optional equipment are constantly being modified. Equipment availability is also subject to change without notice. The most current and accurate information available at the time of publication is included in this manual. Some variation in equipment, description, location, and details can result. Please refer to the manufacturer's literature in the owner's packet.*



**NOTICE**

*The images are shown to assist you with the information presented. Layouts and available features as well as their locations may vary between V series models.*

**M - 1 RAILS & DECK HARDWARE**

Hand and bow rails have been installed to provide security for passengers using the walk-around deck (applicable models) and while outside the cockpit area (i.e. swim platform and bow areas). Limiting passenger movement while underway is recommended. All those on board should be safely seated whenever possible. Additional care must be taken when in rough seas or foul weather. Access to the foredeck should be through the foredeck hatch when running in adverse conditions.



*Four Winns does not recommend occupying the foredeck while underway, during bad weather or on rough seas. DO NOT use walk-around deck (applicable models only), instead use deck hatch and then only if absolutely necessary during any bad weather or rough sea conditions.*

The rail system and hardware fittings have been selected and installed to perform specific functions. Fenders or mooring lines should not be secured to the rails or stanchions. Be certain that a clear lead exists when running dock lines or an anchor line. A line inadvertently threaded around a stanchion or over the rail could cause damage.

The majority of the hardware installed is made of stainless steel. See Figure M1. Regardless of the type of hardware used, periodic maintenance is necessary. Cleaning the hardware with a nonabrasive cleaner will help keep the original shine and beauty. Stainless steel hardware, while quite durable, can become superficially rusted. This can be controlled by cleaning the fittings and applying a coat of wax. Any future rusting can be removed by polishing and rewaxing.



**Figure M1: Stainless Steel Fittings**

**NOTICE**

*All fittings must be periodically inspected for loosening, wear, and damage. Problems should be corrected immediately!*

The cleats that have been installed are specifically designed and are intended to be used as mooring cleats. Their purpose is for securing the vessel to a dock, pier, mooring, or anchor.



*Four Winns® boats are not equipped with any hardware designed for towing purposes. The mooring cleats that are installed on the boat are not to be used for towing another vessel or having the boat towed. Refer to Section A - Operation for additional precautions regarding grounding and towing.*

**M - 2 TRANSOM DOOR**

A transom door is provided and allows access from the cockpit to the swim platform. A door latch is used to secure the transom door closed while underway. The door, when the boat is at rest, may be latched in the opened position for convenience. To prevent a possible man overboard situation, make sure the transom door is closed and secure before becoming underway. See Figure M2.



**Figure M2: Transom Door**  
(Models may vary)



To prevent personal injury, swim platform must not be occupied and transom door must be closed while engines are running.



Prevent falls overboard. Close, latch and stay inside gate while underway.



To prevent personal injury, DO NOT sit on or lean against the transom door.

### M - 3 COMPANIONWAY DOOR

Companionway doors on the V series models are made of acrylic (plexiglass) and provide access to and from the cabin. Depending on the model, the companionway door may be a combination hinged door and sliding hatch assembly or a one-piece sliding companionway door. All doors are lockable. On most models, the companionway door includes a screen for added ventilation and comfort. A hinged stop at the threshold or a strap with snap secures the door in the open position when desired. See Figures M3 & M4.

For cleaning instructions regarding acrylic please see Section Q-7 - Acrylic Plastic (Plexiglass).



**Figure M3: Sliding Companionway Door Shown**



**Figure M4: Companionway Door Keepers**

#### NOTICE

To prevent damage to the companionway door, track, and hatch (if applicable) the companionway door must be opened slowly and carefully during use.

#### NOTICE

Always secure companionway door before operating the boat. Rough water or significant wake could cause the companionway door to slam shut and break. Acrylic plastic is impact resistant but in extreme cases it can crack and/or the track could become damaged if not secured.

### M - 4 WINDOWS

#### A. Windshield

The windshield consist of tempered safety glass. Port and/or starboard windshield wiper(s) may be available depending on the model. On most V series models, the center windshield may be opened to allow ventilation of the cockpit or access to and from the foredeck. See Figures M5 & M6.



We recommend you close and secure the walk-thru windshield while underway. Damage to the windshield could result.



Secure the walk-thru windshield with windshield strap or with other locking device as provided when in open position. Securing the walk-thru windshield will help prevent the windshield from accidentally slamming closed due to high wind and/or wake condition, thus reducing the chance of damage to windshield or injury.



**Figure M5: Windshield**  
(Windshields vary by model)



**Figure M6: Walk-thru Gas Shock Keeper**  
(Certain models only)

The windshield can be cleaned with automotive glass cleaners or dishwashing soap and water. Ensure that a clean cloth is used to prevent scratching the glass.

**NOTICE**

Read the label before using any product. DO NOT use abrasive cleaners.

**B. Cabin/Cockpit Windows**

Plexiglass (acrylic plastic) is used for port holes, cabin windows, skylights, and companionway door assemblies. Plexiglass will scratch easily and must be handled with care.

To clean, follow the instructions located in - Acrylic Plastic (Plexiglass). DO NOT use paper towels. They will scratch the plexiglass.

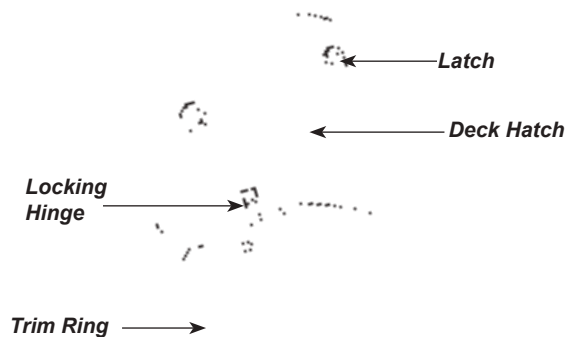
Plexiglass or plastic polish may also be used. Read the label first before using any cleaning product.

**NOTICE**

DO NOT use harsh chemicals or strong cleaning solutions on plexiglass. The surface could be etched, scratched, disfigured, or clouded if an incorrect cleaning solution or chemical is used.

**M - 5 FOREDECK HATCH**

The foredeck hatch consist of a translucent plexiglass. The hatch is supported by one locking hinge and may be secured in a partially open position for ventilation. See Figure M7. Follow the cleaning directions for plexiglass described in Section Q-7 of this manual.



**Figure M7: Forward Deck Hatch**  
(Representative View - Models may vary)




**WARNING**

*Four Winns does not recommend occupying the foredeck while underway, during bad weather or on rough seas. DO NOT use walk-around deck (applicable models only), instead use deck hatch and then only if absolutely necessary during any bad weather or rough sea conditions.*


**CAUTION**

*Make sure deck hatch is closed or be aware of its location when moving around the foredeck to prevent possible injury.*

On most V series models a screen comes with the deck hatch. This feature allows ventilation of the cabin yet keeps the insects out. Also available on certain models. is a “layered” deck hatch system which allows the screen and blind to be slid to the desired position with ease. Also, storage for the screen and blind is built into the screen/shade system. See Figure M8.

Consult the manufacturer’s information in the owner’s packet for specific operating instructions and maintenance regarding your particular deck hatch model.



**Figure M8: Screen/Shade System**  
(Certain models only)

**NOTICE**

*Be sure deck hatch is secured while underway. Damage to the hatch may result.*

## M - 6 COCKPIT REFRESHMENT CENTER or COCKPIT GALLEY

Certain V series models have a cockpit refreshment center while others may have a cockpit galley. The refreshment center may come with such features as a

solid surface countertop, trash receptacle, drink holders, covered sink with faucet, and refrigerator. See Figure M9.



**Figure M9: Cockpit Refreshment Center**  
(Certain Models Only - Model Layouts Vary)

Models that feature a cockpit galley may also include available features such as a solid surface countertop, trash receptacle, under counter storage, drink holders, covered sink with faucet, and refrigerator. A single-burner cook plate may be available for the cockpit galley as well. If so equipped, please refer to the manufacturer’s literature included in the owner’s packet for operation, safety, care and maintenance. See Figure M10.



**Figure M10: Cockpit Galley**  
(Certain Models Only - Model Layouts Vary)

A cockpit refrigerator may be available and if installed operates automatically on 120 volt AC or 12V DC power supply. When both power sources are supplied to the refrigerator, it defaults to AC. When the refrigerator is disconnected from shore power (when AC power is no longer available) the refrigerator switches to DC operation. Note: Typically, cockpit refrigerators run continuously. Please follow the manufacturer’s

instructions regarding the use, care and maintenance of the refrigerator. These instructions are found in the owner's packet.

On certain models an icemaker may be available. If installed, it operates on AC power and will only function when plugged into dockside power or when the generator is running. The icemaker circuitry is protected by the ICEMAKER circuit breaker on the AC cabin electrical panel. Refer to Section H - Electrical Systems for more information as well as the manufacturer's information regarding operation and care.

#### **NOTICE**

Certain icemaker may not be connected to the boat's fresh water system and will not operate without water in the tank.

### **M - 7 COCKPIT TABLE w/MOUNT**

A cockpit table is available on the V series models. The table may be composed of either a laminated fiberglass or teak depending on availability. See Figure M11. The table leg(s) seats into flush floor mount(s) and the table mounts onto the leg(s). Rotating the leg while lifting will ease the removal of the leg from the floor mount. Note: Certain table legs may not be removable but may adjust for certain seating configurations. See Figures M11 & M12.



**Figure M11: Teak Cockpit Table**  
(Representative View - Models may vary)



**Figure M12: Laminated Fiberglass Cockpit Table**  
(Representative View - Models may vary)

### **M - 8 AFT SWIM PLATFORM**

Four Winns provides an aft swim platform on the V series models. For better footing, a skid-resistant surface is provided. The ladder(s) is angled with wide step pads and deep reaching for ease of use and comfort. When not in use the ladder(s) can be folded and concealed in respective ladder storage compartment(s) of the swim platform. A grab handle is located in the ladder lid to assist while boarding. Additionally on certain models, built-in storage tub(s) is available. See Figures M13 - M15.



**Figure M13: Aft Teak Swim Platform**

Also available on many of the models is a teak or Flexiteek swim platform. On certain models a swim platform mat may be installed. If installed, please see Section Q for further information.



**Figure M14: Starboard Boarding Ladder Shown**  
(Quantity & Location of Ladder may vary Depending on Model)



To prevent personal injury, **DO NOT** use the boarding ladder or swim platform while the engines are operating or the boat is in motion. Engine(s) must be off when using the swim platform or boarding ladder. See Preface for specific label information.



Keep hands and fingers away from ladder supports and hinges to prevent injury.

#### NOTICE

Always secure the ladder before boating. Damage to the ladder may otherwise result.



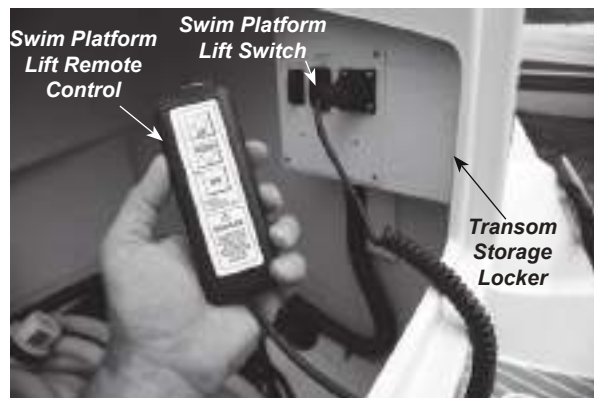
**Figure M15: Port Storage Tub Shown**  
(Certain Models Only)

## M - 9 EXTENDED SWIM PLATFORM LIFT

On certain V series models an extended swim platform with hydraulic lift is available. If the lift is installed, the extended swim platform may be lowered into the water. The control unit to operate the lift is located in the transom storage locker. See Figures M16 & M17. The circuit breaker for the lift is located on the aft circuit breaker panel. Please read the manufacturer's literature regarding operation and maintenance of the swim platform lift.



**Figure M16: Extended Swim Platform Lift**  
(Certain Models Only)



**Figure M17: Extended Swim Platform Lift Control**

## M - 10 TRANSOM STORAGE LOCKER

The transom storage locker, available on certain models, provides storage for such things as dock fenders, personal flotation devices, dockside power cord(s) etc. The storage lockers use latches for easy access. To open, lift the handle. The latches are flush-mounted to prevent injury or accidental opening.

Certain models have a swim platform seat built into the transom storage locker. This seat (if equipped) provides outstanding comfort while enjoying the swim

platform area. The swim platform seat stores in the transom storage locker when not in use. See Figures M18, M19 & M20.



**Figure M18: Transom Storage Locker - Closed**



**Figure M19: Transom Storage Locker - Open**



**Figure M20: Swim Platform Seat**

## M - 11 ELECTRIC GRILL

Grilling is available with an electric grill on certain V series models. The circuit breaker for the electric grill is typically located on the AC cabin panel. Please read the manufacturer's literature regarding operation, safety and maintenance of the grill. See Figures M21 & M22 for examples.



**Figure M21: Electric Grill at Transom**  
(Representative View - Model & Location May Vary)



**Figure M22: Electric BBQ - Cockpit Galley**  
(Representative View - Model & Location May Vary)



Prevent accidental burns. Be sure to turn off the electric grill or BBQ and shut the lid when not in use.



Care must be exercised while grilling. Keep children away from the grill's hot elements. Severe burns could occur.

## M - 12 TRANSOM TABLE

To make swim platform activities even more enjoyable an available transom table can be installed on certain models. The table mount attaches to the transom. The angled table leg and table can be easily installed and removed as desired. See Figure M23.



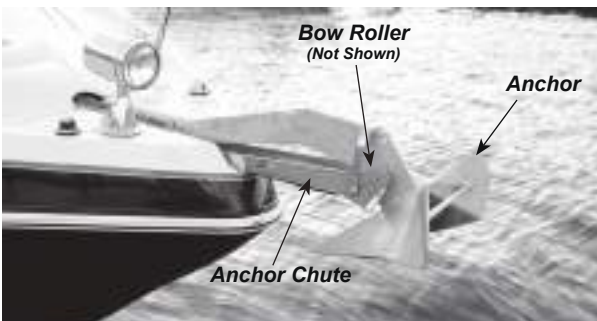
**Figure M23: Transom Table Installed**

## M - 13 BOW PLATFORM

Many of the V series models designed with an integrated bow platform. This bow platform provides a functional base for anchoring. The anchor (if equipped) is stored in the anchor chute of the platform. The anchor chute and bow roller provide support for the chain/rope and anchor which is available. See Figure M24. Refer to Chapman's Piloting, Seamanship and Small Boat Handling or local anchorage authority, such as your Four Winns dealer, for anchor type and size recommendation for your particular model.



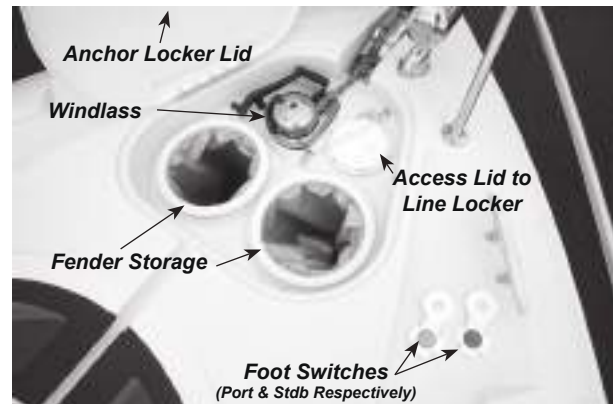
*To prevent a possible man overboard situation, NEVER stand on, or try to utilize the bow platform in any way while the boat is underway.*



**Figure M24: Integrated Bow Platform**

## M - 14 WINDLASS

A windlass is an electrically controlled winch mechanism for retrieving the anchor. The mechanical winch portion is mounted on the bow platform or inside the anchor locker, at the bow. See Figure M25. Most windlasses can be controlled by a set of foot switches mounted on the foredeck or it can be operated from the helm. Circuit breaker(s) is located on the helm and aft circuit breaker panels (if applicable). Refer to the manufacturer's literature included in the owner's packet for windlass operation, safety and maintenance.



**Figure M25: Windlass**

Along with the windlass typically comes an anchor, rope and chain. The anchor line is stored in the anchor line locker located underneath the anchor locker lid. The locker keeps the line secure while underway and keeps the deck clear of unsightly anchor line when docked. See Figure M25.



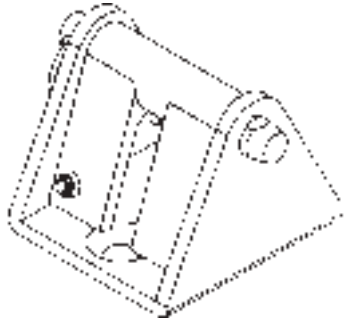
*To prevent personal injury, keep clear of the windlass at all times.*



**Always be sure to raise and secure the anchor prior to operating your boat.** Failure to raise and secure anchor before getting underway could result in severe injury, even death and/or damage to boat from rebounding anchor.

**WARNING**

Always utilize the chain stop or chain stop cable provided with the windlass. The chain stop or chain stop cable prevents the anchor from accidentally releasing while the boat is moving thus preventing damage to the boat or possible injury or death to individual(s) aboard the boat. See Figures M26 and M27.



**Figure M26: Chain Stop**



**Figure M27: Chain Stop Cable**

### M - 15 SPOT/FLOOD LIGHT

A remote controlled spot/flood light is available. The spot/flood light uses an electric motor and helm switch controls to direct the light's beam. See Figure M28. The circuit breaker is located on the helm circuit breaker panel for most models. Refer to Section H-7 and the spot/flood light manufacturer's literature included in the owner's packet.



**Figure M28: Remote Searchlight**

### M - 16 UNDERWATER LIGHTING

Underwater lighting is available if desired. With this feature installed you can enjoy the view below the water. See Figure M29. If installed please refer to the manufacturer's literature included in the owner's packet.



**Figure M29: Underwater Lighting**  
(Representative View Only - Models May Vary)

### M - 17 HARD TOP

The hard top is available on certain V series models. The hardtop is swept forward in design. This presents a sleek look while providing an adequate platform necessary for installation of various navigation and communication equipment. See Figure M30 & M31 for some examples.

Four Winns offers navigational packages for the V series. Refer to Section E - 8N Navigational Equipment for additional information. Please consult with your Four Winns dealer regarding inquiries and availability.



**Figure M30: Hard Top**  
(Certain Models Only)



**Figure M31: "Cabana" Hard Top**  
(Certain Models Only)

## M - 18 ENGINE HATCH w/ ELECTRIC LIFT

The V series models feature an engine hatch with an electric lift or screw jack. The screw jack lifts and lowers the engine hatch by pressing the switch located on the dash. The screw jack runs off the house battery. For quick and convenient engine room access on certain models a day hatch is installed in the engine hatch itself. **Note:** On certain models, when either the day hatch or engine hatch is open the engine room light(s) (if equipped) come on automatically. Exercise care when using steps leading into engine compartment (if applicable). See Figures M32 & M33.



**Figure M32: Electric Lift for Engine Hatch**



**Figure M33: Engine Day Hatch**

To raise the engine hatch:

1. Remove the cockpit table (if applicable).
2. Press the upper (top) portion of the engine hatch switch located on the helm to raise the engine hood to its open position.

### CAUTION

*Do not have person(s) sitting in stern seat or standing on engine hatch while attempting to raise or lower the engine hatch. Possible injury to person(s) and/or damage to engine hatch and components may result.*

### NOTICE

*Never operate your boat with the engine hatch in its open position. Doing so could result in damage to the engine hatch, hardware, and/or loss of cushions.*

 **CAUTION**

*Always close engine and day hatches when not working in engine room. Failure to do so could lead to person accidentally falling into engine room causing injury.*

To lower the engine hatch:

1. Press the lower (bottom) portion of the engine hatch switch located on the helm to lower the engine hatch to its closed position.
2. Reinstall the cockpit table (if applicable).

**NOTICE**

*Cushions, if not properly stored and secured, can blow out of the boat.*

**M - 19 FLAG POLE & HOLDER**

Feel free to show your colors with this available flag pole and holder (flag not included). The flag pole (available for most V series) models may quickly be installed or removed from its holder by pushing in and rotating the pole. See Figure M34. Please consult with your Four Winns dealer regarding inquiries with regard to this popular feature.



**Figure M34: Flag Pole & Holder**





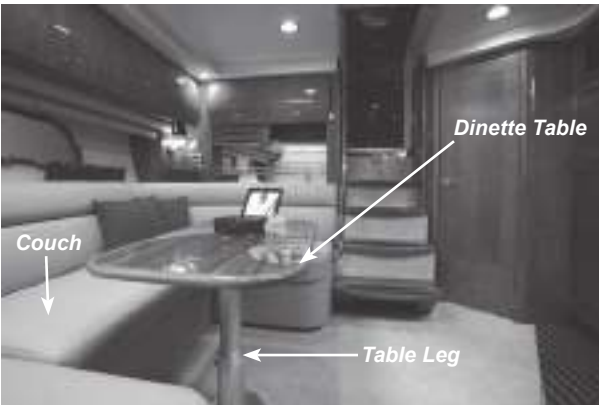
**NOTICE**

The images are shown to assist you with the information presented. Layouts and available features as well as their locations may vary between V series models.

**N - 1 INTERIOR FURNISHINGS**

**A. Couch**

The couch (if applicable) in the salon area of the main cabin converts to a berth. Depending on the model, the dinette table may be used as a support board in conjunction with shorter leg(s). Insert the fill-in cushion to complete the transition. On other V series model the berth requires the removal of the dinette table and table legs completely. Convenient storage may be located underneath the couch seat bases. See Figures N1 - N4.



**Figure N1: Couch  
(Applicable Models Only)**



**Figure N2: Couch Converted to Berth Using Table Leg**



**Figure N3: Couch to Berth w/Table Leg Removed**



**Figure N4: Under Seat Couch Storage**

**B. V-berth or Forward Cabin**

Four Winns provides a forward mattress for the V-berth/forward cabin area on certain V series models. Certain V-berths come with a privacy curtain, under berth storage and hanging locker storage. See Figure N5.



**Figure N5: Fwd Berth Equipped w/Inner Spring Mattress**

A private forward stateroom provides a greater level of privacy and is available on certain models. See Figure N6.



**Figure N6: Private Stateroom**

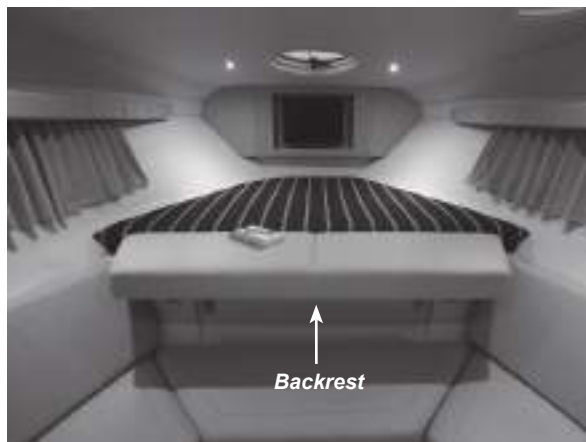
#### NOTICE

*The private stateroom can not be retrofitted to an already existing standard cabin layout. The private stateroom must be ordered and built into the boat at Four Winns.*

Four Winns provides cushions for certain V-berth/forward cabin areas. These cushions are custom shaped to fit the V-berth. See Figure N7. The center backrest may be raised to increase the berthing area. See Figure N8. To gain access to the V-berth storage below simply raise or remove the cushion and storage lid (if applicable). See Figure N9.



**Figure N7: V-Berth/Cabin**



**Figure N8: Backrest Extends to Create Additional Space**



**Figure N9: Under V-Berth Storage**

The cabin may be converted from a dining area to a berthing space by using the dinette table or support board (if applicable), short table leg and fill-in cushions. See Figures N10 and N11.



**Figure N10: V-Berth Dinette Table**



**Figure N11: V-Berth Fill-in Cushions**

**C. Mid Cabin**

The mid cabin provides sleeping quarters with the use of filler cushions and a fill-in support or table (if applicable). Privacy can be obtained through the use of the privacy curtain. The mid cabin also includes a window with screen for ventilation. In certain V series models, access lids are installed below mid cabin cushions for gaining access to and the servicing of various plumbing systems and other equipment. See Figures N112, N13 and N14.

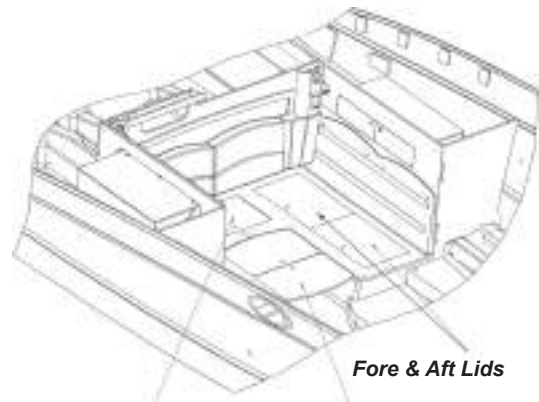


**Figure N12: Mid Cabin**



**Figure N13: Mid Cabin w/ Fill-In Cushions**

**Note: Fill-Ins are also Backrests**



**Center Lid      Fill-In Support**  
**Figure N14: Mid Cabin Access Lids**



**CAUTION**

*To prevent personal injury, be sure the mid cabin fill-in support/table is secure before use.*

Mid cabins on certain V series model may include a queen-size mattress. See Figure M15.



**Figure N15: Mid Cabin**

**D. Mid Cabin Stateroom**

The mid cabin stateroom available on certain models only is either equipped with an oversized twin berths with fitted sheets or a fixed mattress. The twin berths can be converted into one large berth through the use of support boards and fill-in cushions. See Figures N16 and N17.



**Figure N16: Twin Berths**



**Figure N18: Storage Beneath Cushions**



**Figure N17: Mid Cabin w/Fixed Mattress.**

Privacy can be obtained through the use of the woodgrain, locking door. Additional storage may be located beneath the twin berths. See Figure N18.



To prevent personal injury, be sure the mid cabin fill-in supports are secure before use.

## **N - 2 EXTERIOR FURNISHINGS**

### **A. Helm Seat**

The helm seat is adjustable and double wide so it can seat two people comfortably. The driver's portion of the helm seat is adjustable. Depending on the V series model an electronic or a manual, slider mechanism is mounted under the driver's seat. This allows the driver of the boat to adjust the driver's portion of the helm seat to meet his or her needs. There is approximately six inches of adjustment available. The helm seat has available flip-up bolster(s). By simply flipping up the bolster the driver and/or passenger (if available) is able to sit higher in the seat. This is designed to give the driver and/or passenger greater flexibility, increased visibility, and riding comfort. See Figure N19.



**Figure N19: Helm Seat w/Flip-up Bolsters**



*DO NOT sit on the backrest portion of any cockpit seat. The operator could lose control of the boat or passengers could be thrown from the boat. The seat could also be damaged if excessive force is applied.*

On certain V series models, the driver's side armrest is padded for comfort. The armrest is also hinged which allows the armrest portion to be raised to reveal convenient storage below. See Figure N20.



**Figure N20: Helm Seat Under Armrest Storage**

### **B. L-Shaped Stern Seating**

On certain V-series models, the custom L-shape stern seat includes a fiberglass base. The L-shape seating arrangement continues around the back of the boat to create more usable seating area. Under seat storage is readily available under the hinged stern seat cushions. Refer to Figures N21 and N22.



**Figure N21: L-Shape Stern Seating**



**Figure N22: Under Stern Seat Storages**

### **C. U-Shaped Stern Seating**

The custom U-shape stern seat includes a fiberglass base. The U-shape seating arrangement continues around the back of the boat to create more usable seating space and is available on certain V series models. Underseat storage is readily available under the hinged stern seat. Refer to Figures N23 & N24.



**Figure N23: U-Shape Stern Seating**



**Figure N24: Under Seat Storage (Stern Seat)**

Additionally, an aft fill-in seat cushion(s) may be an available feature. This feature extends the cushion area of the stern seat for such things as sunbathing, napping or overnight sleeping. Refer to Figure N25.



**Figure N25: Aft Fill-In Cushions**

#### D. Opposing Bench Seats - Cockpit

Opposing bench seats in the cockpit are available on certain V series models. The cockpit dinette table with adjustable leg along with the fold-down backrests converts the bench seat into a sun lounge. See Figures N 26 & 27.



**Figure N26: Facing Bench Seats**



**Figure N27: Sun Lounge**

#### E. Port Lounge

A port lounge provides comfortable seating and is available on certain V series models. It is conveniently built into an integrated fiberglass base which may also contain a refreshment center. Storage is provided underneath the removable seat cushion. See Figures N28 and N29.



**Figure N28: Port Lounge**



**Figure N29: Under Seat Storage - Port Lounge**

#### F. Swim Platform Seat

Certain models have a swim platform seat available. These seat may vary in design but provide outstanding comfort while enjoying the swim platform area. Certain seats may convert to a sun lounge. See Figures N30, N31 & N32.



**WARNING**

*Prevent falls overboard. Do not occupy swim platform or swim platform seat when engine is running and/or boat is moving. Close the transom door and stay inside cockpit (seated) while underway.*



**Figure N30: Swim Platform Seat - N/A All Models**  
(Stores in Transom Storage Compartment when not in use.)



**Figure N31: Swim Platform Seat - N/A All Models**



**Figure N32: Swim Platform Seat Converted to Lounge**  
(Certain Models Only)

## G. Deck Sunpads

The sunpads are available for the V series models. These cushions securely snap in place and provide comfort while sunbathing on the foredeck. Sunpads will vary between V series models. See Figure N33.



### WARNING

To prevent a possible man overboard situation, **NEVER** occupy the sunpads/foredeck while the boat is underway. Use the sunpads when boat is at rest only.



**Figure N33: Sundeck Pads w/Cabana**  
(Cabana is Available on Certain Models Only)

## N - 3 INTERIOR UPHOLSTERY CARE

### A. Cleaning Interior Fabric/Upholstery

The fabric used in the cabin should be treated the same as fabrics in your home. Periodic vacuuming and gentle cleaning will keep the fabric and upholstery clean and odor free. Spraying the fabric/upholstery with Lysol Spray Disinfectant™ will help retard mildew. For vinyl care see N-4A.

A recommended "Cleaning Kit" includes:

- Blue Coral's Upholstery Cleaner Dri-Clean Plus™ available at Amazon & Automotive Car Care Centers
- Fast & Easy Glass Cleaner™ (to locate the nearest distributor, call 800-537-8990)
- Tough Duty Cleaner™ (to locate the nearest distributor, call 800-537-8990)
- Clean, white towels
- Portable/Compact Deep Cleaner Vacuum (Bissell Spot Lifter™ or similar product)
- Air hose (if available)

To remove stains, please refer to the following list for recommended cleaners.

1. Basic Stains/Ink/Grease/Pencil/Dirt:  
Blue Coral's Upholstery Cleaner Dri-Clean Plus™
2. Adhesives/Teak Oil/Gum/Tar:  
Tough Duty Cleaner™
3. Water Stains:
  - a. While fabric is still wet, use a deep cleaner vacuum to go over the wet area. This will remove the stain from the fabric. It is always best to get the stain before it dries.
  - b. For water stains that have dried, use a deep cleaner vacuum system. Follow the instructions that come with the deep cleaner system. Repeat if necessary.
  - c. If this does not work we recommend a professional cleaning service. One such service is Service Master®. Please call 1-800-937-3783 for the Service Master location nearest you.
4. Tough Stains/Set Water Stains:
  - a. Spray Blue Coral's Upholstery Cleaner Dri-Clean Plus™ on the area, going two (2) inches around the stain or if possible, bring wetness to a break point, such as a bulkhead, etc. Spray water on the same area as directed on the bottle.
  - b. Let set approximately five (5) minutes.
  - c. Rub the area with a clean towel, rotating the towel as the stain is removed. As you rub, go a little beyond the wetness with the towel, flaring the edges.
  - d. Use a deep cleaner type vacuum to remove excess wetness. Allow to dry.
  - e. Repeat if necessary.
  - f. If stain still persists, use a professional cleaning service.

## B. Interior Carpets

Four Winns V series cruisers use a high quality interior grade carpeting. Interior carpeting should be cleaned in the same manner as the carpeting in your home. Vacuuming and occasional rug shampooing are recommended for extended life and appearance. Always conduct a colorfast check on a small area of carpet prior to applying the cleaning solution/shampoo on the entire carpet.

## C. Privacy Curtains

After a season or more use and exposure, you may wish to remove the curtains. Dry cleaning is recommended. Most draperies can be taken down after removing the screw from the end of the curtain track. This screw may not be accessible on some models. Should this be the case, remove the screws securing the end of the track. The track is flexible and can be lowered to remove the end screws.

## N - 4 EXTERIOR UPHOLSTERY CARE

### A. Cleaning Vinyl

#### NOTICE

*Vinyl upholstery should be cleaned and maintained in accordance with the manufacturer's recommendations and instructions.*

The vinyl material used on the exterior upholstery should be cleaned regularly with warm water and a mild dish soap or Vinyl Finish Vinyl Cleaner® using a soft clean cloth, then rinse with a soft clean cloth. For dirt buildup, spray Vinyl Finish Vinyl Cleaner®, let soak for approximately ten (10) minutes, then gently scrub with a soft bristle brush. Be sure to thoroughly rinse the vinyl after washing with mild dish soap or Vinyl Finish Vinyl Cleaner® to remove all residue. Towel dry the vinyl. Periodic spraying of the seats with Lysol Spray Disinfectant™ will help retard mildew.

To further protect the vinyl from early degradation, use 303 Aerospace Vinyl Protectant®. Spray on, then wipe dry. 303 Aerospace Vinyl Protectant should be applied every 3-5 weeks when boat is in use. Regular cleaning with mild soap and water or Vinyl Finish Cleaner will not remove the 303.



**NOTICE**

DO NOT apply vinyl protectants such as Armorall®. The manufacturer does not recommend this product because it removes the oils present in vinyl that keeps vinyl soft.

**A recommended “Cleaning Kit” includes:**

- Ivory Dishwashing Liquid™ and water
- Clean, white towels
- Soft bristle brush
- Denatured Alcohol
- Hemisphere Ink Remover® - (for ordering information call 800-247-9901)
- Vinyl Finish Vinyl Cleaner® - (everyday cleaning & care, call 800-247-9901)
- 303 Aerospace Vinyl Protectant® - (for ordering information call 800-247-9901)
- Tough Duty Cleaner™ - (to locate the nearest distributor, call 800-537-8990)
- Ammonia and hydrogen peroxide

To remove stains, follow the general guidelines listed below and/or refer to the Step-by Step Cleaning Instructions table:

**General Stain Removal Guidelines**
**1. Basic Stains/Grease/Pencil/Dirt:**

Ivory (mild) Dishwashing Soap™ and water, applied with a medium-soft brush or Vinyl Finish Vinyl Cleaner® using a soft clean cloth, then rinse with a soft clean cloth.

**2. Tough Stains/Adhesive/Teak Oil/Rust:**

Tough Duty Cleaner™; rinse with soap and water or spray with Vinyl Finish Vinyl Cleaner®, let soak for approximately ten (10) minutes, then gently scrub with a soft bristle brush. Thoroughly rinse vinyl and dry.

**NOTICE**

To prevent possible damage to the vinyl, rinse with soap and water after applying the Tough Duty Cleaner™ or Vinyl Finish Vinyl Cleaner®. Then rinse and dry.

**3. Ink:**

Denatured alcohol or Hemisphere Ink Remover®.

**4. Mildew Stains:**

To kill bacteria creating the mildew, vigorously brush the stained area with a 4-to-1 mixture of water and ammonia; rinse thoroughly with water and dry.

**5. Tough Mildew Stains:**

Apply a mixture of one (1) teaspoon ammonia, one-fourth (1/4) cup of hydrogen peroxide, and three-fourths (3/4) cup of distilled water; rinse with water and dry.

Step-by-step cleaning instructions				Legend
Type of Stain	STEPS: 1,	2,	3	
General Care	A	B		A. Medium-soft brush, warm soapy water Rinse / Dry
Dirt build-up	A	B		
Ballpoint Ink*	E	B	A	B. Vinyl Finish Vinyl Cleaner® Rinse / Dry
Chewing gum	D	A		
Coffee, tea, chocolate	B			C. One (1) tablespoon of ammonia, one-fourth (1/4) cup of water Rinse / Dry
Grease	D	B		
Household soil	A	B		D. Wipe or scrape off excess (chill gun with ice before hand)
Ketchup	A	B		
Latex paint	A	B		E. Hemisphere Ink Remover Rinse / Dry
Lipstick	A	B		
Mildew or wet leaves*	C	B	A	
Motor oil	B			
Oil-based paint	D	B		
Permanent marker*	E	B	C	
Spray paint	B			
Suntan lotion*	A	B		
Tar / Asphalt	D	B		
Yellow mustard	A	B	C	

All cleaning methods must be followed by a thorough rinse with clean warm water.

Certain household cleaners, powdered abrasives, steel wool and industrial cleaners can cause damage and discoloration and are not recommended. Dry cleaning fluids and lacquer solvents should not be used as they will remove the printed pattern and gloss. Waxes should be used with caution as many contain dyes or solvents that can permanently damage the protective coating.

\*Suntan lotion, tree pollen, wet leaves and some other products can contain dyes that stain permanently. Care should be exercised and boat covers should be utilized.

**Step-By-Step Vinyl Cleaning Instructions Table**

### Do's

- Vinyl Finish Vinyl Cleaner
- Dish Soap (Dawn, Ivory)
- 303 Aerospace Vinyl Protectant

### Don'ts

- Formula 409
- Fantastik
- Simple Green
- Armorall
- Murphy's Oil Soap,
- Son-of-a-Gun
- Bleach / Baking Soda
- Turtle Wax
- Tar Remover

### **NOTICE**

*Failure to care for your vinyl properly, or use of improper cleaners may void your warranty and damage your vinyl.*

### **NOTICE**

*When docking or mooring your boat be aware of your surroundings i.e. trees with pollen, wet leaves, berries etc. These and other items can contain dyes that stain permanently. Utilize weather covers whenever possible to protect vinyl from potential stains.*

### **NOTICE**

**ALWAYS CLEAN STAINS IMMEDIATELY!**  
**DO NOT** use Formula 409™ Fantastik™, Simple Green™, Armorall™, Murphy's Oil Soap™, Son-of-a-Gun™, Bleach / Baking Soda, Turtle Wax™ or Tar Remover on vinyl. Do not use kerosine, gasoline or acetone as they will remove the protective marine topcoat.

### **NOTICE**

*All cleaning methods must be followed by a thorough rinse with water and drying.*

Additional cleaning information is provided by the manufacturer and is included with this manual.

Four Winns offers a variety of optional weather covers for protection of the boat and associated equipment. Continued exposure can damage the upholstery and seating. The seating can become thoroughly satu-

rated with water if not adequately protected. Refer to Section O - Weather Covers for more information.

### **NOTICE**

*The appearance and longevity of the exterior upholstery will be affected by water saturation. Protect these items appropriately.*

## **B. Exterior Carpets**

The removable exterior grade carpeting may be periodically washed with mild laundry soaps or shampooed, dried and reinstalled. It is 100% UV stabilized Olefin™ polypropylene fiber with rubber backing. See Figure N34.

### **NOTICE**

*Prior to using any mild laundry soaps or carpet shampoo, always conduct a color-fast test on a small inconspicuous portion of carpet before applying to entire carpet.*

### **NOTICE**

**DO NOT** dry carpeting in an automatic dryer.



**Figure 34: Cockpit Lay-in Carpet**

## **C. Cleaning and Maintenance**

The following information should be useful in helping you keep your carpet looking well maintained.

Carpet made with Olefin™ fiber possesses built-in stain and soil release for easy, less costly maintenance. Regular vacuuming and occasional shampooing will help it stay attractive and serviceable.

## D. Stain Removal Testing

Even the most stubborn stains can be removed from Olefin fiber following the procedures outlined. Stains were selected as being representative of spills commonly occurring on carpets. Stains were pressed into the carpet to simulate foot pressure following a spill. Stains were applied to a two-inch square section and allowed to penetrate. Removal was performed after two weeks. Carpets were tested for stain removal by an independent laboratory. Stain removal was effective for all the stains selected. Results are shown in the table on the following page.

## E. Stain Removal Procedures

Regular maintenance such as vacuuming, hosing or washing should be performed. Most stains and mildew are easily removed from carpet made with Olefin fiber using common household cleaners. Refer to Table I. Olefin™ fiber is so resistant to chemical attack that Clorox™ bleach may be used to clean up any mildew that may result from excessive wetness.

### Code for stain removal procedure (See Table 1):

“A” Apply warm water and household detergent in minimal amounts to stained area. Sponge or scrape until stain is removed. Rinse with clean water.

“B” Apply warm water and household detergent. Work well into stained area then flush with warm water.

Most stains should be easily removed however, if the stain persists, the cleaning procedure should be repeated to insure stain removal. Remember, the sooner the stain removal process begins, the easier the stain will be to remove.

### NOTICE

*Do not use dry cleaning solvents on carpet or vinyl. Permanent damage to the fiber will result.*

## N - 5 REPLACEMENT UPHOLSTERY

Should upholstery become severely soiled, torn, or in some manner damaged, replacement upholstery cushions are available. Larger upholstery items have separate component parts for easier serviceability. Depending upon the year and model of the boat, most

upholstery parts can be obtained through your Four Winns servicing dealer within a short period of time.

STAIN	REMOVAL PROCEDURE
Automotive Grease	A
Automotive Oil (New or Used)	A
Bacon Grease	A
Berry Stain	A
Blood	A
Butter	A
Catsup or Mustard	A
Chewing Gum	A (Repeat)
Chlorine Bleach (5%)	A
Chocolate (Melted)	A
Clay	A
Coffee or Tea	A
Cola	A
Crayon	B
Dye	A
Egg	A
Feces	A
Fish Formula	A
Fruit Juice	A
Furniture Polish	A
Gravy	A
Ice Cream	A
Ink (Permanent Black)	B
Ink (Scripto, Ballpoint)	B
Iron Rust	A
Lipstick	B
Mayonnaise	A
Milk	A
Latex Paint	A
Oil Base Paint	B
Polish	B
Rust	A
Salad Dressing	A
Shaving Cream or Lotion	A
Tar	B
Urine	A
Vomit	A
Water Colors	A
Wax	B
Wine	A

**Table I: Stain Removal**

**O - 1 GENERAL INFORMATION**

Weather covers are available on all V series models. These Four Winns® covers are designed and intended to provide protection of the cockpit seating areas. Cover availability as well as installation techniques may vary by model. The information discussed in this section attempts to cover most V series cover installations. Please contact your Four Winns dealer if you have questions regarding your specific V series model's canvas installation.

Four Winns utilizes 100% acrylic-type material for most of its canvas. During the manufacturing of the weather covers, the smallest possible needle and highest quality UV stabilized, bonded polyester thread is used in the stitching.



*Never use any form of open flame cooking device in any area fully enclosed or near weather covers. This material is flammable.*

The weather cover is water repellent but not water proof. During a hard rain, you may notice a light mist permeating through a weather cover. This is normal. If the seams leak, they can be sprayed with Scotch-guard™ or similar type water repellent or a seam sealing compound can be applied. Keep objects from contacting the inside of the cover. Leakage may occur at point of contact.

Weather covers must be installed “snug” to prevent sags. The material relies on swelling to seal itself. If too taut or overly tight, the material will not seal and may tear.

**NOTICE**

*Periodically check weather covers for accumulation of water. Damage to the bow assemblies may otherwise result. Make sure cover is snug to avoid puddling of water.*

After use, the top canvas should be rolled up into the storage boot (if applicable) and secured.

**NOTICE**

*NEVER fold or store a wet weather cover. This can lead to mildew or shrinkage. Roll rather than fold the enclosure curtains. Sharp folds increase the chance of cracking the clear vinyl.*

**NOTICE**

*DO NOT use the weather covers for outdoor winter storage. The weight of the snow or heavy rain can cause severe damage to the material or top structure. Refer to O-6 - Winter Storage in this manual for more information.*

Four Winns is utilizing snaps for the canvas. The snap sockets are a standard type. To unsnap, gently lift on the snap.

**NOTICE**

*Remove snaps one at a time to prevent damage. DO NOT rip off or pull the weather cover as a whole; acrylic material will tear at snaps.*

**O - 2 GENERAL CANVAS INSTALLATION GUIDELINES**

- 1) For safety and ease, it is recommended that two or more people are available to install or remove the canvas.
- 2) Ideally, canvas should be installed while the boat is in the slip or moored securely.
- 3) Be sure to observe all safety precautions to prevent the build-up of Carbon Monoxide - an invisible, odorless gas while the boat is running or underway.
- 4) Store canvas pieces flat, or if necessary, rolled; do not fold.
- 5) Bimini top, valances and/or camper top must be installed first; all other pieces attach to these pieces.
- 6) Partially zip zippers until all sides of a canvas piece are in position.

- 7) Support poles are adjustable; a button-release lets you slide the inner and outer tube to longer or shorter settings for a snug fit.
- 8) Unsnap canvas by lifting at the button to prevent damage; do not pull/yank.
- 9) Clean canvas with warm water, mild soap and a soft brush. For the clear Isinglass pieces use a soft, clean cloth. Be certain to rinse cloth often to remove any dirt collected in the cloth that could scratch the clear vinyl.
- 10) Applicable models which have a bimini top and camper top it is important to make sure your bimini these tops are properly centered prior to installing the Isinglass enclosures.

### O - 3 BIMINI TOP

#### NOTICE

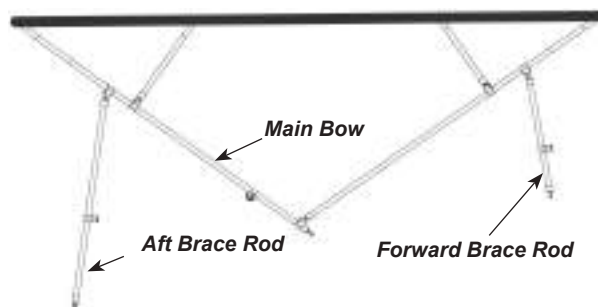
*Two people are recommended for installation or removal of canvas should it become necessary. Care must be exercised to prevent damage to the boat and/or radar arch (if applicable). Use a protective covering to prevent damage to arch if necessary.*

#### A. Bimini Top without Hardtop

This type of canvas (certain V series models only) is a “freestanding” top and is supported only by the bow assembly. Note: This style of canvas when deployed permits most occupants the ability to stand and walk about the cockpit while the boat is at rest.

To install:

1. Attach the bimini main bow to the ball & socket mounts (if not already attached) and unboot the bimini from its canvas storage boot. See Figure O1.



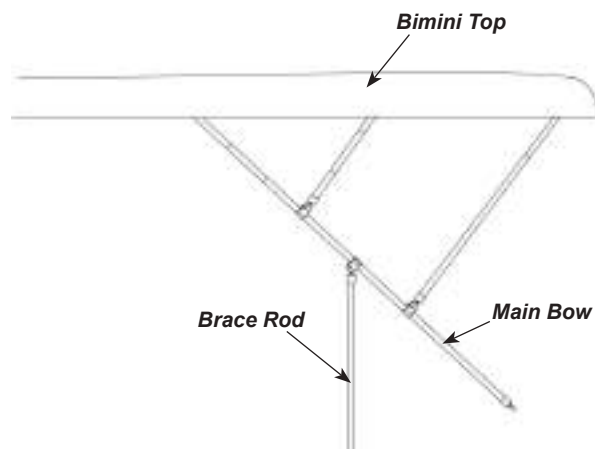
**Figure O1: Bimini Top without Hardtop**

2. Extend the rear portion of the bimini and attach the aft brace rods to the aft deck hinge mounts.
3. Extend the forward portion of the bimini and attach the forward brace rods to their respective forward ball & socket mounts. If straps are used instead of forward brace rods, attach straps to the strap eyes mounts on the deck. Adjust straps for tautness as needed.

To close and boot (mounted storage) the bimini top reverse the preceding steps. Please note that tucking the bimini top inside boot while zipping is required.

#### B. Bimini Top with Hardtop

The bimini top (if available) and provides cover/shade for the cockpit area. It is designed to be fastened to the hardtop with the use of a track. See Figure O2.



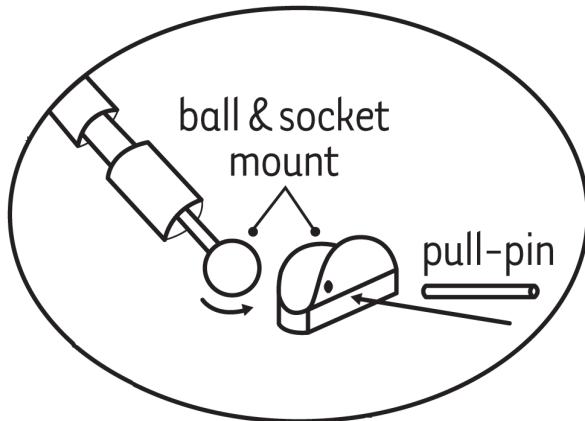
**Figure O2: Bimini Top**

The bimini top is factory installed, therefore, minimal adjustment should be necessary.

To install the bimini top:

- 1) Starting with the main bow, attach the bimini frame using the ball and socket mounts. See Figure O3.

- 2) Attach the brace rods in the similar manor.



**Figure O3: Ball & Socket Mount**

- 3) Slide the bimini top into the track on hardtop; center visually.
- 4) Place bimini top over the bimini frame. Position the zipper pocket over aft frame and zip the pocket around the frame.
- 5) Repeat placing pockets around the remaining bows and zip to hold in place.
- 6) Lower the rear adjustable support pole to create tension on the bimini top (if applicable).

For bimini top removal, reverse the previously described procedure.

**NOTICE**

*Canvas should be snug. If too taut or extremely tight, canvas could tear or pull at seams.*

**NOTICE**

*Both the bimini and camper canvas have been designed and are intended to remain installed on the boat in the upright "stored" position. Four Winns does not recommend the bimini and/or camper assembly be removed from the boat unless absolutely necessary.*

**NOTICE**

*The bimini and camper canvas is designed as temporary shelter only. It should not be left up unattended for any length of time. Violent weather could result in expensive damage. Misues is not covered under warranty.*

**NOTICE**

*In the event the canvas requires some maintenance or repair, remove the bimini camper canvas from the bow assembly. Unzip the bow sleeves, unsnap all snaps and straps, and remove the canvas.*

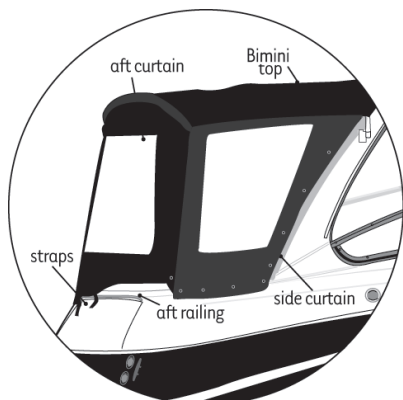
**O - 4 CAMPER CANVAS**

The camper canvas is available on certain V series models and provides cover/shade for the aft portion of the cockpit area. Forward connector curtains made up of clear plastic (izinglass) encloses the forward cockpit area. See Figure O4.



**Figure O4: Camper Canvas**

These curtains are connected to the hardtop (if applicable) by a track system and snap to the windshield. Note: In a camper canvas without arch configuration, all curtains attach directly to the bimini top. The camper curtains used in conjunction with the bimini top, forward connector and bimini side curtains completely encloses the cockpit area when desired. See Figure O5.



**Figure O5: Camper Side & Aft Curtain Installation**

To install the camper canvas:

- 1) Install the bimini top as previously described.
- 2) Using the locator tags (if applicable), find the side curtains. See Figure O5.
- 3) Starting at the top, start each zipper.
- 4) When all zippers have been started, complete zipping.
- 5) Snap the side curtains to the boat.
- 6) Smooth all velcro down (if applicable).
- 7) Locate the aft curtain.
- 8) Zip the aft curtain to the curtain top, starting at the center.
- 9) Secure with a strap to the aft railing or snap to transom.
- 10) Zip to port and starboard curtains.
- 11) Snap to boot.
- 12) Secure and smooth all velcro (if applicable).

For camper storage, reverse the procedure described above.

**NOTICE**

**DO NOT FOLD THE AFT OR SIDE CURTAINS!** Damage may result. Always roll the side and aft curtains up to prevent damage to the isinglass (clear plastic).

This camper is designed as temporary shelter only. It should not be left up unattended for any extended length of time. Violent weather could result in expensive damage. Misuse is not covered under warranty.


**FOUR WINNS®**

**O - 5 COCKPIT COVER**

The cockpit cover is available on certain V series models and is used to cover the complete cockpit area and is intended as a short term storage cover. See Figure O6.



**Figure O6: Cockpit Cover**  
(Representative View Only - Models may vary)

To install the cockpit canvas:

- 1) A cockpit cover is intended for short term storage only. Do not operate the vessel with the cockpit cover installed due to the potential for carbon monoxide gas build-up.
- 2) Using the locator tag, find the center point on the canvas and attach it to the center point of the windshield.
- 3) Working outward equally in both directions, continue snapping the canvas in position.
- 4) When the canvas extends far enough, separate the velcro strips and install the cover around the bimini support poles. Reattach and smooth out

the velcro. Slide the awning track into the flexarail. Attach to the inside of the hardtop.

- 5) Install support poles loosely - without a lot of tension at this point.
- 6) Attach straps to aft rail and pull to adjust. See Figure O5.
- 7) Raise support poles to keep water from pooling on top of canvas.
- 8) Snap walk-thru area and visually check all your work.

#### NOTICE

*It is recommended that you retain your canvas locator tags. In the event that replacement parts are needed, contact your Four Winns dealer.*

## O - 6 OTHER CANVAS INSTALLATION

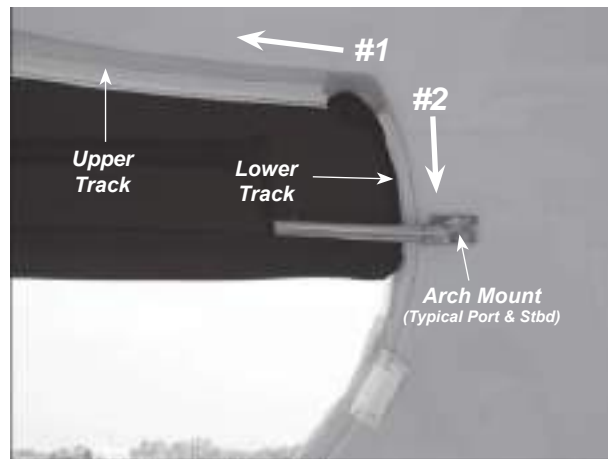
The canvas top and curtain set which connect to the top are available on certain V series and provide cover/shade for the stern portion of the cockpit area. It is designed to be fastened to the hard top with the use of a track and supported with stainless steel bow and support poles. The aft curtain and side curtains can be installed to completely enclose the aft cockpit area. Izinglass (clear vinyl) windows with screens are installed in the curtains. These windows may be rolled up and secured to allow ventilation into the cockpit area. See Figure O7.



**Figure O7: Canvas Top & Curtain Set**

To install canvas:

- 1) Orient the canvas top to match the orientation of the hard top. Ensure the interior seams will be facing inside. Starting at either end, thread the opposite end of the canvas through the upper track of the hard top (#1). Continue feeding the canvas all the way through the track until completely threaded. Feed ends of canvas top into the lower track running down the hard top (#2). See Figure O8. Once the canvas top is installed in the tracks, allow it to hang in place.



**Figure O8: Upper & Lower Tracks and Arch Mount**

- 2) Attach the stainless steel bow to the port and starboard arch mounts using an adjustable wrench. See Figure O8.
- 3) Attach the support poles to the respective port and starboard deck mounts located at the transom. Slide the support poles down into the deck mount and secure with the pin and lanyard. See Figure O9.



**Figure O9: Bow Support Pole Deck Mount**  
(Typical Port & Starboard)

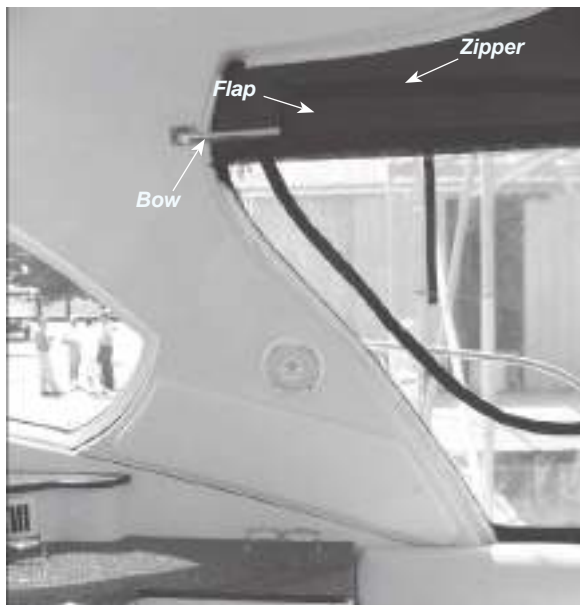


- 4) Lower the adjustable supports using the button-release. The button-release lets you slide the inner and outer tube to longer or shorter settings for a snug or loose fit. Doing so may make attaching the top canvas to the bow easier. See Figure O10.



**Figure O10: Adjustable Bow Support Poles**

- 5) Place the canvas top over the bow. Wrap the zippered-flap portion of the top around the bow and zip securely in place. See Figure O11.



**Figure O11: Zippered-Flap Portion of Canvas Top**

- 6) Raise the adjustable supports using the button-release in order to make the canvas top taut. See Figures O10 and O12.



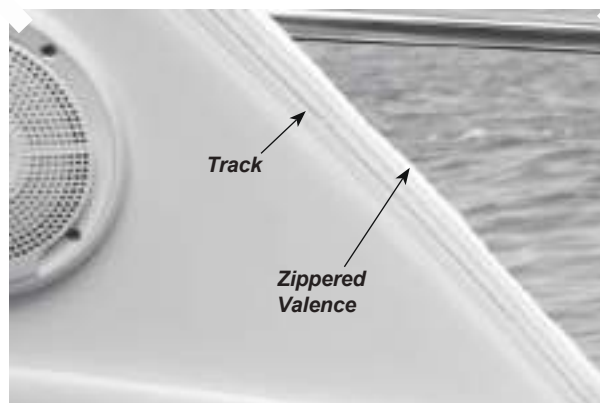
**Figure O12: Canvas Top**

#### NOTICE

*Canvas should be snug. If overly taut or extremely tight, canvas could tear or pull at seams.*

To install the sides & aft curtains:

- 1) Lower the adjustable supports using the button-release. The button-release lets you slide the inner and outer tube to longer or shorter settings for a snug or loose fit. Doing so may make attaching the sides & aft canvas to the boat easier. See Figure O9.
- 2) Valances, small areas of canvas curtain, are used to attach the side curtains to the boat. The valances slide through a track mounted on the hard top. The side curtains are then attached to the valances using zippers. See Figure O13.



**Figure O13: Side Curtain Valance**

- 3) Starting at the top, start each zipper.
- 4) When all zippers have been started, complete zipping.
- 5) Snap the side curtains to the boat.
- 6) Zip the aft curtain to the canvas top, starting at one end. See Figure O14.



**Figure O14: Aft Curtain**

- 7) Zip to port and starboard curtains.
- 8) Secure the bottom of curtains to the transom of the boat using the snaps.
- 9) Raise the adjustable supports using the button-release in order to make the canvas sides & aft curtains taut. See Figures O10 and O14.
- 10) Secure and smooth all velcro.

**NOTICE**

*The canvas top has been designed and intended to remain installed on the boat. Four Winns does not recommend the canvas top and bow assembly be removed from the boat unless necessary or desired.*

**NOTICE**

*Two people are recommended if removal or installation becomes necessary. Care must be exercised so the hard top does not become damaged. Use a protective covering to prevent damage to hard top if necessary.*

**NOTICE**

*In the event the canvas top requires some maintenance or repair, remove the canvas top from the bow assembly.*

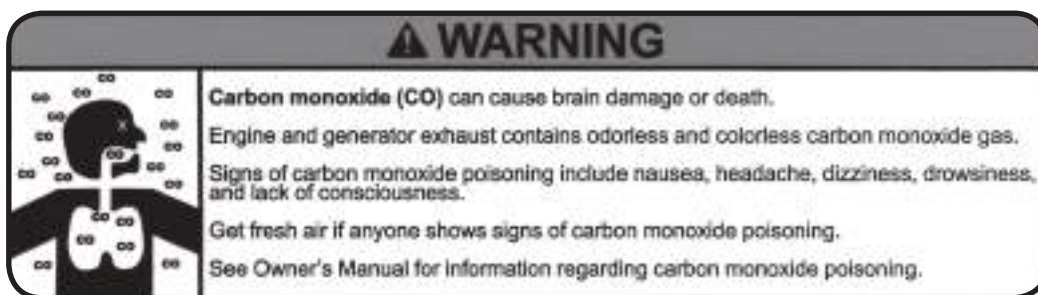
**NOTICE**

*It is recommended that you retain your canvas locator tags. In the event that replacement parts are needed, contact your Four Winns dealer.*

**O - 7 USE OF WEATHER COVERS AND CARBON MONOXIDE**

When an engine is running, a natural vacuum may exist with the right wind and sea conditions to allow exhaust gases (which includes carbon monoxide) to seep into the boat. When canvas is utilized, this compounds the possibility of this occurring and inhibits natural ventilation. For more information, refer to Section B-2 - Carbon Monoxide in this manual.

The carbon monoxide in exhaust fumes can be hazardous. It is important for you and your passengers to be aware of the potential safety hazard created by exhaust fumes. Familiarize yourself with the symptoms of individuals overcome by carbon monoxide, and most importantly, ways you can protect yourself and your guests. See Figures O15 - Carbon Monoxide Canvas Warning Label and Figure O16 - Carbon Monoxide Warning Label.



**Figure O15: Carbon Monoxide Warning Label**

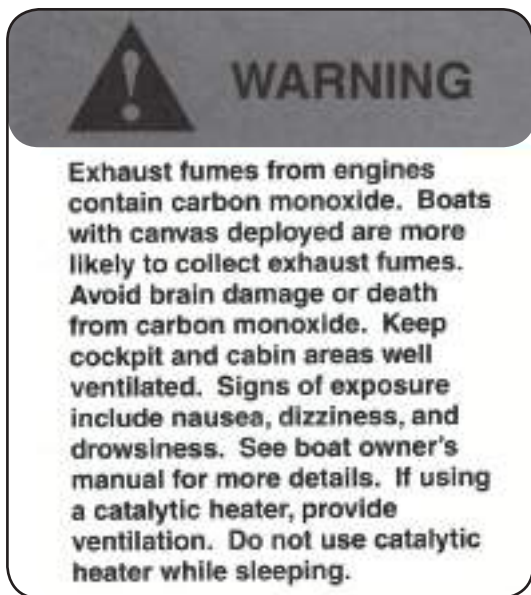


Figure O16: Carbon Monoxide Canvas Warning Label

## O - 8 WINTER STORAGE

The boat must be properly protected during winter dry dock storage. A winter storage cover is advisable. Many marine dealers offer shrinkwrap enclosures for outdoor storage. See a Four Winns dealer for information on the availability of winter storage covers or other alternatives for storage.

When storing outdoors, make sure the supporting framework keeps the weight of the snow and rain from accumulating on the storage cover. Proper ventilation must also be provided or dry rot and mildew will occur. See Section R - General Maintenance for additional winter storage information.

## O - 9 MAINTENANCE

Moisture, dirt, chemicals from industrial fallout, heat, ultraviolet rays and in some cases, salt water are factors which affect the longevity of acrylic covers. See Figure O17.

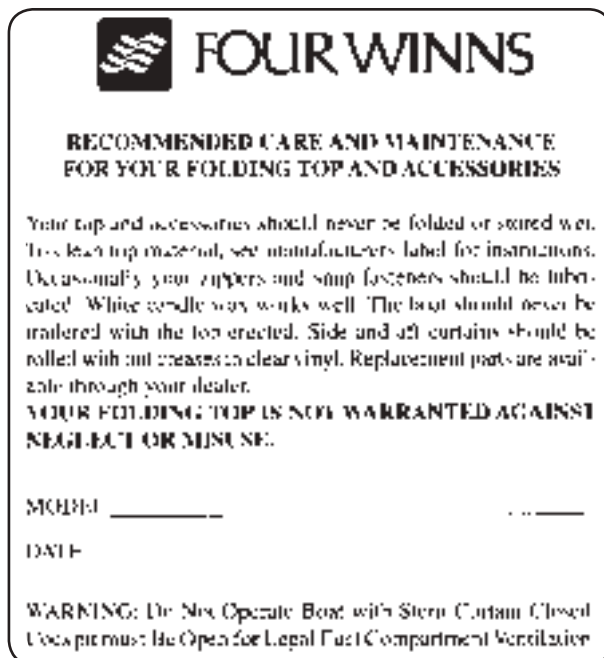


Figure O17: Canvas Care & Maintenance Tag

1. Moisture can cause shrinkage and mildew. Allow the cover to dry thoroughly before disassembling tops. Keep it clean and well ventilated to prevent mildew. Spraying the weather cover with Lysol Disinfectant™ or similar product will help prevent mildew.
2. Dirt creates a starting point for mildew when moisture is present. Clean the top with a sponge or soft scrub brush and mild detergent when the cover is installed. Make sure cover is snug to help prevent shrinkage.
3. Chemicals cause decay if allowed to accumulate for long periods of time. Keep the cover clean to prevent decay.
4. Heat can cause cracks in vinyl components and stiffening of fabric when enclosed in plastic or polyethylene. DO NOT store the weather cover in polyethylene under direct sunlight or high temperature situations.
5. Ultraviolet degradation may occur under prolonged exposure to direct sunlight. Store the top in the boat when not in use.
6. Salt water can corrode brass, aluminum, or stainless steel fittings and fasteners. Keep fittings clean, lubricated, and waxed to prevent corrosion.

Clear vinyl curtains and windows demand extra care to prevent scratching. Hose clean water onto vinyl to rinse off salt, dirt, or grime prior to using a soft, clean cloth. Dirt or grit in the cloth will scratch the vinyl window. Be sure to rinse cloth often.

**NOTICE**

*DO NOT use hot water. DO NOT dry in an automatic dryer. DO NOT dry clean or steam press.*

Leakage after cleaning may be the result of insufficient rinsing. Re-rinse. If leakage continues, apply a coat of silicone air drying water repellent, such as Scotchguard™. See your Four Winns dealer for additional information on weather covers.



## **P - 1 HULL DESIGN INFORMATION**

Four Winns® boats are designed using the sound engineering and mathematical principles of hydrostatics, hydrodynamics, structure, and strength of materials. The materials utilized provide optimum strength at the lightest possible weight. The exact fiberglass laminate schedule and construction techniques of each part is determined in accordance with the strength and rigidity required.

## **P - 2 FIBERGLASS CONSTRUCTION**

The fiberglass components of Four Winns® boats are of the finest quality materials, workmanship and construction techniques available. This ensures the structural integrity to provide years of boating enjoyment with minimal maintenance.

The construction of a Four Winns® hull begins with the application of gel coat to the mold. The gel coat is approximately 25 mils thick. A coat of resin and chopped fiberglass is then sprayed into the hull and carefully hand rolled until it is securely affixed to the gel coat.

A number of fiberglass layers and woven roving are applied to the above laminate. Each layer is hand laid and hand rolled. The keel and chine areas have fiberglass woven roving overlapped in these areas to provide additional strength. Most V Series models utilize encapsulated end-grain balsa core or coremat laminates to achieve additional rigidity. Others utilize additional laminations of woven roving to maintain strength and rigidity.

The hull support stringers are located using special tools, and are fiberglassed and/or bonded into place. This ensures a strong, rigid hull, permanently formed into a solid assembly, free of distortions.

Fiberglass cockpit liners and seat base are constructed similar to the hull. Balsa core or coremat laminations are utilized when necessary.

In addition to a thorough visual inspection of each fiberglass component, samples are measured using special equipment, for fiberglass reinforcement to resin ratio, laminate configuration, weight and thickness. By these procedures Four Winns ensures proper composition.

## **P - 3 EQUIPMENT INSTALLATION**

Many boats are used for specific purposes or under conditions which require the addition of special equipment to the hull or deck. Special care must be taken during the installation of any equipment to a fiberglass component. A polysulfide or butyl based sealant should be used to seal installations below the water line. Silicone "marine" seal or similar bedding compound should be used elsewhere.

### **NOTICE**

*DO NOT install any item onto or through the hull without adequately sealing the hull area penetrated by the installed item or related fasteners. Improper installations could cause leakage or allow water absorption and thus cause serious hull damage.*

*Always pre-drill fastening holes with a proper size bit. Pre-drilling will help prevent the fiberglass from splintering and thus causing unsightly damage. Also, countersink holes to prevent the gel coat from chipping.*

Any equipment which will be subjected to cyclic loading or significant force should be through-bolted to a fiberglass component. A butt block or backing plate should be used to strengthen any area onto which an item will be mounted.

## **P - 4 FIBERGLASS CARE & MAINTENANCE**

Fiberglass is affected by weathering processes and requires maintenance on a periodic basis to help maintain the beauty and shine. The effects upon the gel coat will be dependent upon boating conditions, storage, type of use, and the care given to the boat during the boating season.

Four Winns utilizes fade-fighting gel coat in the exterior finish. It is specially formulated to resist fading and yellowing, and retain more of its original gloss than better grade gel coats. However, it is still important to maintain the gel coat to protect the finish.

### **A. General Maintenance**

For fresh water use, the boat should be washed once or twice a month. When using in a salt water environment, considerably more care will be necessary. Be careful when selecting a cleaning agent. Hand dish

washing detergents are usually gentle and are recommended for cleaning gel coat. Cleaning products such as Ivory™ or Dawn™ hand dish washing liquid can be safely used. Always read the label before using any product.

#### **NOTICE**

*DO NOT use acetone, paint thinner, solvents, or strong alkaline based detergents, nor cleaners with a “gritty” and abrasive texture. Avoid products which contain sodium phosphate. Common examples of these types of household cleaning agents are: Tide™, Oxydol™, Janitor-in-a-Drum™, Fantastik™, Clorox™, etc. Always read the label before using an agent.*

There are several products available which are specifically designed to clean fiberglass exterior finishes. Many companies like Johnson & Johnson®, Turtle Wax®, etc. manufacture cleaning fluids mild enough to clean without stripping the wax.

#### **NOTICE**

*Treading on a soiled fiberglass surface can severely scratch and mar the finish. Keep the fiberglass as clean as possible.*

When cleaning skid-resistant areas, DO NOT attempt to use a wire brush or sandpaper because this will remove the skid-resistant gel.

Apply wax once or twice a year to maintain gel coat lustre. Read the label before using any product. Make sure product is formulated for gel coat surfaces. Also, consult a Four Winns dealer for their recommendations.

#### **NOTICE**

*Do not use carnuba based waxes. This type of wax yellows over time and makes the fiberglass appear yellow.*



*Waxing decks, cockpit floors or other walking areas is not recommended. Waxing will produce a very slippery surface, especially when wet. Wax may also buildup in the skid-resistant surfaces. Be sure all persons wear deck shoes while aboard the boat. Footing will be improved and feet will be protected from accidental cuts and bruises.*

A darkening or discoloration of the skid-resistant surfaces can sometimes occur as a result of wax buildup. Exposure to the sun and elements can turn the wax darker, or occasionally can cause it to become flaky or powdery. To remove, use fine rubbing compound and a low rpm buffer (1200 to 2000 rpm). Apply light pressure and keep the buffer moving at all times to prevent heat build-up. Read the directions before using any equipment.

#### **B. Weathering Effects on Gel Coat**

Weathering occurs from direct sunlight, water, chemicals, and dust. Some of the terms below describe the changes that can occur to the gel coat surface.

Chalking is a result of the gel coat's top surface being broken down into an extremely fine powder. When this happens, the color whitens. The chalk is present on the surface only.

Fading is the uniform change in color. This happens when the actual pigments have changed color, especially from excessive chalking, or when the gel coat has either been stained or bleached by something.

Yellowing is gel coat which has a yellow cast and streaking usually deals with a stain or contact with another surface.

Gloss refers to the shine of the surface. This can change from sanding action, chalk, residues, or exposure.

Blistering refers to a condition in which the unprotected gel coat surface below the waterline has absorbed water and formed bubbles. See Section P-5 for additional information.

Follow the ensuing instructions for boats that have weathered and chalked.

1. Wash.
2. Wax. If this does not work, then use a fine rubbing compound. If this does not work use 400 or 600 wet or dry sandpaper, followed by fine rubbing compound and wax.

When using wax or fine rubbing compounds, make sure to read the label and follow the directions. Some helpful tips are listed below.

1. Avoid working in direct sunlight. This dries out the wax or compound, and can stain the surface.
2. Use clean pads or cloths to apply a thin coating of wax or rubbing compound to a small area such as three feet by three feet. Remove any excess, and then rub the area with a buffing pad, or power buffer. Apply pressure only as necessary to restore the surface finish. Applying too much pressure or buffing in one place too long can permanently damage the surface.
3. After applying compound, always follow with waxing.

#### NOTICE

*If using a power buffer, use a low RPM buffer with light pressure. Keep the pad wet and the buffer moving at all times to prevent heat buildup.*

#### NOTICE

*To prevent gouges, uneven areas, or other damage from occurring, DO NOT use a power or belt sander when sanding. For best results, block sand the gel coat.*

### C. Stains

Stains can appear anywhere on the exterior of the boat and may be a result of contact with tar, plant sap, leaves, rust from metal fittings, and other materials. Surface stains may be removed with hand dish washing soap, mild cleansers, or some household detergents. DO NOT use chlorine or ammonia products. These products can affect the color of gel coat. Commercial car washes use strong cleaners and should be avoided.

To remove stains, refer to the following procedures.

1. Wash area with hand dish washing soap.
2. Begin with a small area such as three feet by three feet and apply a mild cleanser.
3. Rinse with clean water.
4. Follow with compound and waxing as outlined in procedure above.

If the stain is not removed by the hand dish washing soap or mild cleanser, then the next procedure is to use either denatured or rubbing alcohol. If this does not work, consult your Four Winns dealer for professional assistance.

#### NOTICE

*DO NOT use acetone, ketone, or other solvents to remove stains. These chemicals are flammable and may damage the gel coat.*

### P - 5 FIBERGLASS REPAIRS

Fiberglass is one of the most durable, strong, and forgiving construction materials afloat. It is resilient and normal repairs can be made without affecting the strength or structural integrity of the boat.

#### WARNING

*Striking docks, other boats, or submerged objects could create a very hazardous situation or severely damage the fiberglass. In the event an object is struck below or near the waterline, proceed directly and cautiously to the nearest service facility and remove the boat from the water. Closely inspect the hull for damage. If the outer fiberglass laminate was penetrated, repairs must be made prior to relaunch.*

Occasionally, blisters, crazing, scratches or damage to fiberglass can occur. Repairs may be necessary to correct the problem.

#### A. Scratches

Scratches occur during normal use. The following is a step by step procedure to repair scratches.

1. Clean area with soap and water.
2. Apply a fine rubbing compound and buff.

### 3. Wax.

If this does not work, clean the area and sand lightly with 400 to 600 wet or dry sandpaper and follow with rubbing compound and wax.

## B. Gouges & Cracks

Stress cracks and crazing are the appearance of hairline cracks in the gel coat surface. When present, these problems usually occur in the gel coat finish or the outer “skin coat” fiberglass laminate. The appearance of these cracks does not pose a threat to the structural integrity of the boat. In most cases, they are cosmetic and can be treated.

Cosmetic surface damage can be repaired as follows:

1. Sand the surrounding area with medium or fine grit sandpaper. Clean all marine growth, dirt, anti-fouling paint, etc. from the immediate area. DO NOT excessively scratch or gouge the surrounding area.
2. Use a hard, pointed tool to open the gel crack. Take care not to damage the surrounding gel coat.
3. Sand the crack or gouge so the edges are smooth and will allow proper “feathering” of the area.
4. Clean the area thoroughly. Make sure the area is dry before proceeding.

### NOTICE

*Be sure the structure and the ambient temperature are above 60 degrees F (15 degrees C) and the relative humidity below 70% immediately before, during, and after the repair.*

5. If the nick or gouge is deep and penetrates through the gel coat, fill the area with fiberglass patching paste. Follow the directions on the can when mixing the paste with the catalyst.
6. After the gouge is filled and has dried, sand the patched area. Begin by using medium-fine grade sandpaper. Progressively use finer grade sandpaper until the surface is very smooth. If necessary, add filler and then sand the surface again.
7. Apply two or three light coats of matching fiberglass gel coat to the repaired area. Enough gel

coat should be used so that the entire area is covered. The gel coat must be catalyzed using up to 2% MEK Peroxide which can be purchased at a supplier handling fiberglass reinforced products. Contact your Four Winns dealer for assistance.

8. After ample drying time, sand the area using very fine wet/dry sandpaper. If the appearance of the area is still not satisfactory, repeat steps 2 through 4 as necessary.
9. If above the waterline, polish the area using a fiberglass rubbing compound and then wax. If the repaired area is below the waterline, the area should be primed and painted in accordance with the anti-fouling paint manufacturer’s instructions.

Gel coat, like paint, will change colors with time and exposure to sunlight (ultraviolet). For this reason, “matching” gel coat obtained from Four Winns may not match the gel color of a boat that has been exposed. However, this is the closest match commercially available. A fiberglass technician can tint the gel to be used in the repair to provide a closer color match.

More severe fiberglass damage, especially when structural, requires the expertise of an experienced fiberglass repair technician. See your Four Winns dealer for assistance.

### NOTICE

*Improper repair techniques can lead to further fiberglass component damage.*

## C. Osmotic Blistering

Osmotic blistering or “boat pox” is an unfortunate but not uncommon occurrence in fiberglass boats. Fiberglass is water retardant, not waterproof. When a boat is left in the water for a period of time, the fiberglass will absorb water. It is a natural process that can not be eliminated in production methods or material selection and usage. However, there are ways to control and possibly prevent blisters (see Section P-6). If you do encounter blisters, be assured that the blisters are merely cosmetic. They do not indicate a defect in the boat structure or lamination. Four Winns, along with most boat manufacturers, regard gel blisters as a standard maintenance item.



The repair procedure for gel coat blisters is similar to the procedures outlined in the previous section on cracks and gouges. There is an exception however, in that the hull must dry out for several days or possibly weeks before repairs can proceed.

To determine if the hull has dried sufficiently, tape one square foot of household plastic wrap securely to the hull bottom. Make sure all edges are sealed and let it stand for twenty-four hours. If condensation has accumulated under the plastic, the hull is still “wet” and must be allowed to dry longer before repairing.

When the repair is completed, an application of an epoxy barrier coat should be considered. This will help prevent the possibility of reoccurrence of blisters. Your Four Winns dealer or local ship store will have information on barrier coat products.

## P - 6 ANTI-FOULING PAINT

Four Winns recommends anti-fouling or bottom paint for boats which will be kept in the water for extended periods of time. Anti-fouling paint reacts with water to retard the growth of algae, barnacles and other marine growth on the hull. In addition to marine growth, it offers protection against excessive water pollution.

### NOTICE

*Most countries have introduced legislation controlling the use of anti-fouling agents. **Always abide by these regulations.***

Anti-fouling paint begins reaction upon contact with water. After a season’s use or sooner under certain conditions, the anti-fouling paint may appear to be dissolving. This is due to the paint’s chemical emission that in turn retards marine growth. When this occurs, refinishing is in order. Consult your engine operator’s manual for their recommendations regarding drive-unit and anti-fouling paint.

Four Winns recommends reapplication of the anti-fouling paint seasonally. The effectiveness of the paint will be drastically reduced if used longer. Though Four Winns has found the use of anti-fouling paints provide good marine growth protection in most water, other paints may be more effective in certain water conditions. See a Four Winns dealer for recommendations on anti-fouling paint use in your area.

### NOTICE

*During surface preparation, the hull should be sanded only enough to remove any foreign matter, and loose paint. **DO NOT** sand deeply into the gel coat, fiberglass cosmetic problems could later result. After sanding, the surface should be wiped with a rag treated with a cleaner recommended by the anti-fouling paint manufacturer. The surface must be clean and slightly rough to ensure proper paint adhesion.*

Prior to application of the anti-fouling paint, the boat owner may consider coating the hull bottom with an epoxy coating. Four Winns recommends this procedure as a preventive and effective means of controlling osmotic blistering. Most major anti-fouling paint manufacturers also supply a line of epoxy undercoatings. Consult your Four Winns dealer for recommendations on epoxy undercoatings.

## P - 7 HULL SUPPORT

Proper support of the hull while it is out of the water is imperative. Due to the design complexities, Four Winns does not recommend storage cradles be homemade. The boat is a valuable piece of equipment. **DO NOT** risk permanent damage to the hull structure in an attempt to save the cost of an adequate support. Improper support can lead to serious and permanent hull deformation.

### CAUTION

*While lifting the boat, ensure slings are in the proper locations as indicated by the sling location labels. Failure to do so may result in permanent hull structure damage and will invalidate the hull structure warranty.*

### NOTICE

*When attempting to raise the hull, never allow one end of the boat to rise first, while letting the opposite rest momentarily on the drive(s) or underwater gear. Serious damage to these components could result. **DO NOT** place lifting straps on drive(s) or underwater gear. Be sure the strap is against the hull surface only and are in proper location as indicated by the sling label location.*

A storage cradle designed for a larger or smaller boat will not provide proper support for the hull. This could lead to hull deformation and thus serious performance deficiencies. Four Winns offers a storage cradle built to properly fit your V series. Contact your Four Winns dealer for details.



**NOTICE**

*V series layouts and content do vary based on model size, standards and options available. Material availability is subject to change without notice. The information included in this section is intended as a general guideline only. Always read the label before using any cleaning product.*

**Q - 1 HIGH-PRESSURE LAMINATE CARE**

Much of the V series interior components such as the shelving, closets, closet door and drawer fronts consist of a high pressure laminate material. See Figure Q1. The finish is that of a synthetic wood and can be cleaned with hand dish washing soap and water as well as furniture polish. Always read the label before using any product.



**Figure Q1: High-Pressure Laminate**  
(Representative View - Models Will Vary)

**NOTICE**

*DO NOT use abrasive cleaners or solvents on laminate. DO NOT use Soft Scrub soap or similar cleaning products; they will scratch the surface and remove the shine.*

**Q - 2 REAL WOOD TRIM**

Four Winns uses real wood trim throughout the interior. The wood is prepared with a light stain followed by a polyurethane finish. To clean, a damp cloth or furniture polish will usually suffice. Care should be similar to that of fine, household furniture. See Figure Q2.



**Figure Q2: Real Wood Tables**  
(Representative View - Models Will Vary)

**Q - 3 STAR BOARD**

Star board is a high density polyethylene (plastic) and is very durable and fade resistant. Star board requires little maintenance, and is being used in place of wood in certain areas of the boat.

To clean star board, use a solvent-free, nonabrasive cleaner such as hand dish washing soap and water. Read the label before using any cleaning product.

**NOTICE**

*Star board will stain when exposed to certain oils or chemicals. Always wipe up any spills immediately.*

**Q - 4 LAMINATED FIBERGLASS**

Certain components such as cockpit table, transom table, seat bases, storage tubs, storage lids/doors, ect. may consist of a laminated fiberglass material. These components may be cleaned with mild dish washing soap and water. After washing, a light coat of wax may be applied as necessary. Always read the label before using any product. See Figures Q3 & Q4.



**Figure Q3: Cockpit Table**



**Figure Q4: Transom Table**  
(Available on Certain V series Models Only)

## Q - 5 TEAK

Teak tables, cockpits and swim platforms are available on certain V series models. See Figures Q4 & Q5.



**Figure Q4: Teak Cockpit Table**



**Figure Q5: Teak Cockpit & Swim Platform**

Before teak can be given any coating, it must be completely cleaned. Follow the manufacturer's directions with regard to cleaning. Once cleaning has been accomplished there are finishes that may be

applied such as teak oil (traditional), sealers, or varnishing. Again, Four Winns recommends following the table manufacturer recommendations. Additional note: There are numerous teak products on the market that may be tried that will give you the look you desire. Your Four Winns dealer can also provide you with some helpful suggestions.

### NOTICE

*DO NOT use abrasive cleaners or solvents on cockpit table. DO NOT use Soft Scrub™ soap or similar cleaning products; they will scratch the surface and remove the shine.*

### NOTICE

*DO NOT use tables as a cutting board. The knife will leave gouges/marks in the surface of the table. Use an actual cutting board in order to protect the tables.*

## Q - 6 SOLID SURFACE MATERIAL

Solid surface material is utilized in various countertops found in various parts of the boat such as the galley, cockpit refreshment center, and head to name a few. The solid surface gives these countertops a rich look and makes for an extremely strong yet lightweight top. It can be cleaned with hand dish washing soap and water. Always read the label before using any product. See Figures Q6 - Q8.



**Figure Q6: Galley Countertop**  
(Representative View - Models Will Vary)



**Figure Q7: Cockpit Refreshment Center**  
(Representative View - Models Will Vary)

**NOTICE**

*DO NOT set hot pans or dishes directly on the countertop. The countertop may become burnt and/or discolored. Use of a hot pad will prevent any discoloration from occurring.*

**NOTICE**

*DO NOT use countertop as a cutting board. The knife will leave gouges/marks in the surface of the countertop. A cutting board that fits over the sink is provided.*



**Figure Q8: Head Sink w/ Solid Surface Countertop**  
(Representative View - Models will vary)

**NOTICE**

*DO NOT use abrasive cleaners or solvents on countertop. DO NOT use Soft Scrub™ soap or similar cleaning products; they will scratch the surface and remove the shine.*

**Q - 7 Acrylic Plastic (Plexiglass)**

Acrylic plastic is utilized in the companionway doors, transom doors, deck hatches, portlight windows, skylights, sliding storage doors, electrical panel doors, cabinets and cabin windows. See Figure Q9.



**Figure Q9: Companionway Door**  
(Representative View - Models Will Vary)

To clean acrylic plastic:

- 1) Rinse with plenty of water to wash off as much dirt as possible.
- 2) Using your bare hand, along with plenty of water, feel and remove any dried on dirt or mud. Do not use fingernails to scrape as this could scratch the plexiglass.
- 3) Wash using a soft, grit free cloth or sponge and mild, nonabrasive soap or detergent.
- 4) Blot dry using a clean, damp chamois.

**NOTICE**

**Never use a dry cloth, duster, glass cleaning solutions or citrus cleaner on acrylic plastic.**

**NOTICE**

**Do not use solvents such as acetone, silicone spray, benzene, carbon tetrachloride, fire extinguisher fluid, dry cleaning fluid, lacquer thinner or ammonia. These solutions attack the acrylic surface.**

You can use fine automotive acrylic rubbing and polishing compounds to remove fine scratches on acrylic.

**Q - 8 AQUA FLEX SWIM PLATFORM MAT**

Available for the swim platform on certain V series models is an Aqua Flex mat. See Figure Q10. This mat is bonded to the fiberglass swim platform using adhesive and is typically installed by Four Winns. This mat provides a comfortable surface for enjoying those watersport activities.



**Figure Q10: Aqua Flex Swim Platform Mat**

Aqua Flex Care Instructions:

1. If possible keep covered while in storage or not in use.
2. Spills: Scoop or scrape up as much of spill as possible and follow by blotting the remaining spot with a dry clean cloth. - Paper towel can be substituted when cloth is not available.
3. Non-Oil Based Stained: Make a detergent solution by adding a ¼ inch teaspoon liquid dish detergent to 1 cup warm water. Apply solution to the affected area and blot - (DO NOT SCRUB) with a dry clean cloth, repeat process until stain stops

transferring to the cloth. If stain still appears, apply solution to area let stand 2-5 minutes and rinse with clean water.

4. Oil Based Stains: Apply Naphtha or mineral spirits to effected area and follow the instructions on the solvent container. - Always work the stain from the outside toward the center - (DO NOT SCRUB).
5. If Stain Still Appears: Surface can be restored by lightly sanding area with 24-36 grit sandpaper. (Sanded area may appear slightly lighter but it will blend over time).

**Q - 9 FLEXITEEK**

Available on certain V series is a flexiteek cockpit and/or swim platform. Flexiteek is made up of a composite PVC based material with a surprising similarity and look to that of real teak. Flexiteek can be cleaned with mild dishwashing detergent. Please contact your Four Winns dealer for further details. See Figures Q11 and Q12.



**Figure Q11: Flexiteek Cockpit**



**Figure Q12: Flexiteek Swim Platforms**

**R - 1 WINTERIZATION****A. Prior to Lifting for Winter Lay-up**

1. Pump out the head (dockside discharge), and gray water holding tank (if applicable). Be sure the holding tank(s) is empty. Flush the waste and gray water holding tanks with soap, water and a deodorizer (e.g., Lysol Liquid™). Add more water if necessary. Have the cleaning solution pumped out.
2. Have the fuel tank either full or completely empty. Ensure the fill-cap is tightly secured. See the Engine Owner's manual for recommendations. Also check with the dry dock operators for recommendations. A diesel additive may be recommended to prevent bacterial growth in the fuel.

**NOTICE**

*If the fuel has been treated with a diesel additive to prevent bacterial growth, run engines for ten minutes to make sure the treated fuel is present in all lines and parts of the engines.*

3. Drain water from the fresh water system and the hot water heater.
4. Before winterizing the engine, flush out the system according to the specific engine owner's manual. The engine flush out should be used to clean the engine of unwanted salt, mud, sludge, etc. which may have accumulated in the engine cooling system.
5. Winterize the engine and drive systems in accordance with the engine owner's manual. Portions of this winterization procedure may require that the boat be lifted. Winterization of engine and boat systems should be performed by qualified service personnel. Repair and/or replacement costs associated with frozen engine components are quite substantial.
6. Lift the boat only at the designated "sling" labels. See Section P-7 - Hull Support and the Preface of this manual for additional details.

**B. After Lifting**

1. Remove the drain plug.
2. Thoroughly wash the fiberglass exterior, especially the hull bottom. Remove as much marine growth as possible. Wax lightly. Use extreme care if using a high pressure washer. See engine manual for special concerns.
3. Lower boat onto cradle properly. Be sure boat is adequately supported. The boat should be raised slightly under the forward supports to improve drainage to the transom drain.
4. Be sure all the water is completely drained from the fresh water system. Disconnect all hoses, check valves, etc. and blow all the water from the system using very low air pressure. The use of nontoxic, fresh water system antifreeze is recommended as an alternative to disassembling the water system. Refer to Section J-8 - System Maintenance in this manual for information on winterizing the water system.
5. Winterize the toilets as recommended by the toilet manufacturer. The boat is equipped with a waste holding tank, mix some RV antifreeze solution and pour it into the head toilets. Transfer some of the antifreeze to the holding tank by flushing the toilets. Also, refer to Section J-8 - System Maintenance for additional information.
6. Winterize the optional gray water system (if applicable). Take some RV antifreeze solution and pour it down the various sink and shower drains. Transfer some of the antifreeze to the holding tank by pouring it down the gray water pumpout fitting.
7. Drain or winterize the air conditioning and generator system (if applicable). Follow the appropriate manufacturer's directions. Be sure all water intake filters are drained thoroughly.
8. Ensure that all water is removed from the sump pump, bilge pump and bilge pump lines. Dry the hull bilge, and self-bailing cockpit drain troughs. Water freezing in these areas could cause damage. See Section K-3 - Hull Drainage Systems.
9. Drain the alcohol out of the stove (if applicable) and store alcohol in a cool, dry place away from heat or spark.

10. Remove the batteries and store in a cool place. Clean the batteries using clear, clean water. Be sure the battery has sufficient water and clean terminals. Keep the batteries charged throughout the storage period. **DO NOT** store the batteries on a concrete floor or other damp or conductive surface.
  11. Clean the boat interior thoroughly. Vacuum carpets, and dry clean drapes and upholstery jackets as necessary.
  12. Wash exterior fiberglass components, wax lightly.
  13. Clean exterior upholstery with hand dish washing soap and water, rinse, and dry thoroughly.
  14. Remove all oxidation from exterior hardware and apply a light film of moisture - displacing lubricant.
5. **DO NOT** use the canvas top and canvas curtains as a winter storage cover. The life of these covers may be significantly shortened if exposed to harsh weather elements for long periods.

#### **NOTICE**

*Boats stored outside in areas with heavy snow accumulation are more susceptible to damage, and should be inspected regularly during the winter months.*

### **C. Prior to Winter Storage**

1. Remove as many cushions as possible. Remove storage lids or hatches. Open as many locker doors, as possible. Open the refrigerator door. Leave these areas open to improve ventilation.
2. Spray the weather covers and the boat upholstery with Lysol Spray Disinfectant™. Enclosed areas such as the refrigerator, shower basin, storage locker areas, etc. should also be sprayed with Lysol Disinfectant™.
3. Place small dishes of rodent poison such as D-Con™ in a number of areas around the boat. Be sure dishes are placed near the head and the engines, as rodents will destroy upholstery, water intake and discharge hoses.
4. If the boat will be in outside storage, properly support a storage cover and secure it over the boat. **DO NOT** secure the cover tightly to the boat. This does not allow adequate ventilation and can lead to dry rot. **DO NOT** store the boat in a damp storage enclosure. Excessive dampness can cause electrical problems, corrosion, and dry rot.



*Placing an electric or fuel burning heating unit in the bilge of the boat during cold weather could cause fire or explosion and is not recommended.*



**R - 2 GENERAL MAINTENANCE SCHEDULE**

SERVICE	AT LAUNCH AND FIRST OPERATION*	25 HOUR CHECK EACH SEASON*	BI-SEASONALLY OR EVERY 6 MONTHS OR EVERY 100 HOURS*	SEASONALLY OR EVERY 12 MONTHS OR EVERY 200 HOURS*
Engine and Instrumentation	Refer to Section E			
Engine Maintenance	As Recommended by the Manufacturer			
Inspect Exhaust System Hoses and Connections				
Inspect Cooling System Hoses, Connections and Impellers				
Check Propellers				
Check All Thru-Hull Fittings				
Gauge / Display Cleaning				
Controls Systems	Refer to Section F			
Throttle and Shift Adjustment				
Neutral Safety Switch Test				
Cable and Control Lubrication				
Steering Systems	Refer to Section G			
Linkage and Connection Inspection (If Applicable)				
Stem Drive Torque Tab Adjustment (If Applicable)				
Power Steering Service	As Recommended by the Manufacturer			
Steering Adjustments				
Steering System Lubrication				
Electrical Systems	Refer to Section H			
Inspect Battery Connections				
Check Battery Water				
Battery Cable Inspection				
12 Volt Electrical Equipment Operation				
12 Volt Wiring and Connection Inspection				
120 Volt Electrical Equipment Operation				
120 Volt Wiring Inspection				
120 Volt System Continuity Test				
Shore Power Cord and Adapter Inspection (If Applicable)				
Polarity Light Operation				
Receptacle and Connection Inspection				
Generator Maintenance (If Applicable)	As Recommended by the Manufacturer			
Inspect Generator Water Intake and Exhaust				

\* Or as Required

 - Shaded areas indicate the time frame when service/inspection should be conducted.

SERVICE	AT LAUNCH AND FIRST OPERATION*	25 HOUR CHECK EACH SEASON*	BI-SEASONALLY OR EVERY 6 MONTHS OR EVERY 100 HOURS*	SEASONALLY OR EVERY 12 MONTHS OR EVERY 200 HOURS*
Fuel System	Refer to Section I			
Inspect for Leaks				
Fuel Sender Inspection				
Fuel Filter Inspection				
Fuel Tank(s) Inspection				
Water Systems	Refer to Section J			
Inspect All Water Systems				
Fresh, Grey & Holding Tank Inspections (If Applicable)				
Drain & Flush Fresh Water System				
Drain & Flush Waste Water System				
Drain & Flush Grey Water System				
Ventilation and Drainage	Refer to Section K			
Engine Blower Operation	Before Every Use			
Head Blower Operation				
Blower Vent System Cleaning				
Bilge Pump Operation and Cleaning	Before Every Use			
Check Transom Drain Plug				
Deck Hatch, Porthole & Aft Window Cabin Operation				
Interior Equipment	Refer to Section L			
Air Conditioner (If Applicable)	As Recommended by the Manufacturer			
Head / Toilet Maintenance	As Recommended by the Manufacturer			
Thru-Hull Fitting Inspection				
Icemaker and Refrigerator Cleaning (If Applicable)				
Clean Cooler	As Required			
Inspect Stove Fuel System (If Applicable)				
Stove Maintenance (If Applicable)	As Recommended by the Manufacturer			
Exterior Equipment	Refer to Section M			
Check PFD's for Serviceability and Correct Number	As Required			
Check Charge of Fire Extinguishers	As Required			
Clean Spotlight (If Applicable)				
Check Compass for Magnetic Deviation (If Applicable)				
Windlass Maintenance (If Applicable)	As Recommended by the Manufacturer			
Check Trim Tab Fluid Level (If Applicable)				
Check Trim Tab System for Leakage				

\* Or as Required

 — Shaded areas indicate the time frame when service/inspection should be conducted.

SERVICE	AT LAUNCH AND FIRST OPERATION*	25 HOUR CHECK EACH SEASON*	BI-SEASONALLY OR EVERY 6 MONTHS OR EVERY 100 HOURS*	SEASONALLY OR EVERY 12 MONTHS OR EVERY 200 HOURS*
Clean Windshield	As Needed			
Upholstery	Refer to Section N			
Clean Upholstery				
Clean Carpet				
Spray Upholstery with Lysol				
Check Seat Hinges and Mounting Hardware				
Weather Covers	Refer to Section O			
Wash Weather Covers				
Spray Weather Covers with Lysol				
Fiberglass Components and Hull	Refer to Section P			
Check All Fastenings (securing rails, seats, etc.)				
Clean Fiberglass Thoroughly				
Wax Hull Sides and All Non-Tread Areas				
Inspect Fiberglass Areas for Damage				
Perform Minor Touch-Up Repairs				
Sand Hull and Re-Apply Anti-Fouling Paint				
Woodwork & Composite Maintenance	Refer to Section Q			
Clean Wood Trim & Wood Table (If Applicable)	As Needed			
Clean Star Board	As Needed			
Clean Cockpit Tables / Countertops	As Needed			
Clean Plexiglass Components	As Needed			

\* Or as Required   – Shaded areas indicate the time frame when service/inspection should be conducted.

**S - 1 GENERAL TRAILER INFORMATION**
**NOTICE**

*Trailer models may vary. Please consult the trailer component manufacturer's information in your owner's packet for additional information.*

The trailer must properly "match" the boat's weight and hull design. Four Winns trailers are designed specifically for the Four Winns models only. Please consult our website at [www.fourwinns.com](http://www.fourwinns.com) or your Four Winns dealer for applicable trailer models. Four Winns trailers meet or exceed the National Marine Manufacturers Association's trailer requirements.

Four Winns manufactures bunk type trailers for the "trailerable" V series models only. The bunks are located specifically for Four Winns boats and adequately support all parts of the boat. It is a "drive-on" type trailer which means winching the boat from the water is not normally necessary.

**NOTICE**

*If winching the boat onto the trailer, **be sure the bunks are wet to prevent damage to the boat or trailer.** DO NOT attempt to winch the boat forward when out of the water. Damage to the winch stand/assembly or tongue could occur.*

Four Winns offers trailers with a painted finish or trailers with GatorHyde™ protective coating. The painted trailer is intended to be used in fresh water and the GatorHyde™ trailer in salt/brackish water.

**NOTICE**

*Four Winns does not recommend the usage of painted trailers for salt/brackish water conditions, as trailer life may be substantially reduced.*

**A. Regulations**

Federal law requires that the trailer and tire registration information be compiled and recorded. The Four Winns® boat registration includes trailer registration information. A tire registration form, included in the owner's packet, is to be filled out and returned to the tire manufacturer. Please see Section S-7 - "Supplemental Trailer Information" for additional information to assist you in completing the tire registration form.

**NOTICE**
**Manufacturer's Tire Registry**

*Ensure to fill out your name and address on the tire registration form provided in your owners packet. Mail it to the tire manufacturer for the purposes of compliance with Federal defect notification regulations.*

Laws covering such items as trailer brakes, lights, safety chains, etc., will vary from state to state. Please contact the motor vehicle department in your state for additional information.

**B. Load Carrying Capacity**

The certification label shows the maximum load-carrying capacity and is located on the port forward side of the trailer. The Gross Vehicle Weight Rating (GVWR) is the load-carrying capacity plus the weight of the trailer itself. DO NOT exceed the GVWR rating for the trailer.

**NOTICE**

*When using or choosing a tow vehicle with the correct GVWR, you must consider not only the weight of the boat and trailer but also the weight of the fuel, water, equipment, etc. Refer to Table 1 below:*

EQUIPMENT	WEIGHT (AVERAGE)
Battery	60 Lbs./Battery
Fuel	6.5 Lbs./Gal.
Water	8 Lbs./Gal.
Accessories	150 Lbs. (Approximate)

**Table 1: Average Equipment Weight**

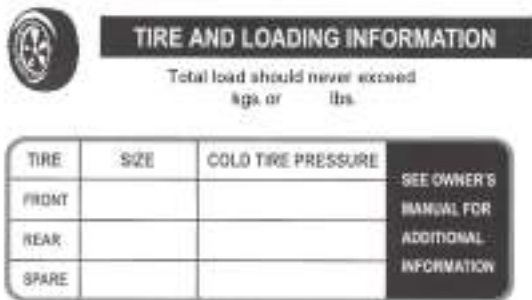
If selecting a trailer from another manufacturer, check the load-carrying capacity. A trailer with a load-carrying capacity that is too low will be unsafe on the highway and could cause sudden failure of critical trailer components or abnormal tire wear. A trailer with too high of a load-carrying capacity that is sprung for heavy loads can damage a lighter boat.

**NOTICE**

*DO NOT overload your trailer by placing camping gear or other heavy equipment in the boat. DO NOT exceed the GVWR rating. Damage to the hitch, coupler, or trailer may occur.*

For trailers, the steps to determining correct load limit are:

- (1) Locate the statement “The weight of cargo should never exceed the XXX kg or XXX lbs.” on your vehicle’s placard. See Figure S1.
- (2) This figure equals the available amount of cargo and luggage load capacity.
- (3) Determine the combined weight of luggage and cargo being loaded on the vehicle. That weight may not safely exceed the available cargo and luggage load capacity.



**Figure S1: Tire Label**

Improper weight distribution can place excessive strain on the towing vehicle and trailer. It can also cause the trailer to “fishtail” (sway side to side). Be sure gear and other items are distributed evenly in the boat.

**C. Hitches**

The load-carrying capacity of trailer hitches will vary between manufacturers and must equal or exceed the GVWR. Four Winns trailers use surge brake systems and require a fixed hitch. Refer to Section S-2D Surge Brakes for more information.

Before hitching the trailer to the vehicle, make sure the proper size hitch ball is installed to match the coupler. The ball size is determined by the Gross

Vehicle Weight Rating or GVWR. The GVWR is printed either on the trailer plate or embossed on the tongue, coupler or actuator. For trailers with a GVWR of 7000 pounds or less a 2” ball is used. For trailers with a GVWR over 7000 pounds a 2 5/16” ball is used. This information may also be obtained on our website at [www.fourwinns.com](http://www.fourwinns.com). Refer to Section S-3 Operation for additional information on hitches. Also, consult your Four Winns dealer for his recommendation before purchasing a trailer hitch for your towing vehicle.



*To help guard against a sudden failure while in use, **do not use a worn hitch ball.** Replace all worn or damaged parts.*

**S - 2 TRAILER COMPONENTS**

**A. Bunk Supports**

All bunk boards are made of pressure treated wood. This wood is rot resistant. All boards are covered with a high quality exterior grade carpet to protect the boat from damage during normal use.

Bunk supports run parallel to the keel and support the hull, extending beyond the transom. See Figure S2.



**Figure S2: Trailer Bunks**

Outer bunk supports provide stability for the boat. The inside bunks are the main weight bearing members. Side guide-on supports (certain models only) help to keep the boat straight while driving the boat onto the trailer. Keeping the tie-downs tightly fastened will prevent the boat from bouncing against the bunk supports.

**NOTICE**

*Improper trailer setup can cause hull damage.*

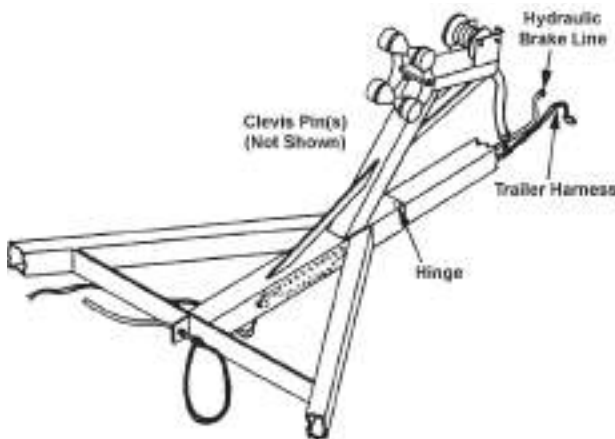
## B. Tongue

Four Winns trailers are designed with tongue weights between 7% and 11% of the total weight of the boat, fuel, gear and trailer. If the downward weight on the coupling ball does not fall within this range, coupler failure and towing instability may occur. If using another manufacturer's trailer, have the dealer check the tongue weight before trailering.

### NOTICE

*DO NOT use a bent or damaged tongue or coupler. Replacement parts may be ordered through a Four Winns dealer.*

On some models the trailer tongue is hinged. This allows for easier storage. The tongue is attached with clevis pin(s) with locking hair pin(s) or clevis pin keeper(s) to the trailer frame. Refer to Figure S3.



**Figure S3: Trailer Tongue Assembly**

To pivot the tongue on trailers models with exposed hinges:

1. Make sure the trailer jack is supporting the trailer load properly. Refer to Section S-2C on Swivel Jacks for additional information.
2. Disconnect the trailer from the tow vehicle.
3. Unplug the trailer's wire harness from the tow vehicle's trunk connector.
4. Remove the clevis pin keeper and clevis pin.

### NOTICE

*The tongue will exert some pressure on the clevis pins. It may be necessary to lift, push or wiggle the tongue to remove the clevis pins.*

5. Pivot the tongue towards the trailer as far as it will go.

To reinstall, follow this procedure in reverse order.

1. Pivot the tongue until the clevis pin holes aligned.

### NOTICE

*When extending tongue ensure that the brake line and wire harness are not pinched. Failure to check could result in damage.*

2. Insert clevis pin. **Always** be sure to insert clevis pin from the top and insert the clevis pin keeper.

### NOTICE

*The tongue will exert some pressure on the clevis pins. It may be necessary to lift, push or wiggle the tongue to insert the clevis pins.*

### CAUTION

*Make sure the trailer tongue is secure before hitching to the towing vehicle.*

4. If towing the trailer, remember to plug the 5-wire tongue harness to the trunk connector wire harness of your tow vehicle.

## C. Swivel Jack

The jack is designed to lift, lower and support the tongues of the trailers when not connected to the towing vehicle. Before unhitching the trailer, use the following guidelines when setting up the jack.

1. Pull on the locking pin release. See Figure S4.



**Figure S4: Swivel Jack**  
(Representative View - Models May Vary)

2. Swivel jack to the vertical position.
3. Release the locking pin release and make sure the pin fully engages to lock the swivel jack in place.

 **CAUTION**

*Be sure dirt, sand, ice, etc., does not obstruct the proper seating of the lock pin.*

4. When raising or lowering the jack, prevent the caster from rotating while cranking. Make sure the jack is planted on a firm and level surface before unhitching the trailer. Be sure to block the trailer's wheels should it be parked on an incline and removed from the tow vehicle.

 **WARNING**

*To prevent personal injury or damage to the boat and trailer, observe the following:*

- *NEVER pull on the lock pin when any trailer weight is on the trailer jack.*
- *DO NOT move the trailer when resting on the swivel jack. Use towing vehicle to move the boat and trailer.*
- *Keep body and feet clear of trailer tongue when raising or lowering jack.*

Always remember to swivel jack to the horizontal position before towing the trailer. Damage to the caster and jack may result.

The swivel jack provided on the certain Four Winns trailer can be removed from the trailer to allow for maintenance or repairs. Follow the manufacturer's recommendations provided in the owner's packet.

#### **D. Surge Brakes & Coupling Assembly**

Surge brakes are available on certain Four Winns trailers. When equipped, surge brakes operate automatically when the tow vehicle's brakes are applied. When the tow vehicle slows down or stops, the forward momentum or "surge" of the trailer against the hitch ball applies pressure to a master cylinder in the trailer coupler. The master cylinder supplies hydraulic pressure through the hydraulic system which activates the trailer's disc brakes. See Figure S5. Please refer to the manufacturer's literature included in your owner's packet for further details regarding operation and maintenance.

To hitch the trailer to the tow vehicle, place the coupler latch in the open position to unlock the coupler. See Figure S5. Push down on the coupler latch to lock the trailer to the ball hitch. Push coupler latch lever back until the latch engages and is properly seated. The safety pin, provided with the trailer, or a padlock **must be inserted completely** in the forward coupler latch hole. This helps ensure the coupler's latch remains in the locked position during towing of the trailer. Refer to Section S-3 Operation for additional information on couplers and hitching to the tow vehicle.

## NOTICE

Anti-sway devices as used on recreational vehicles (RV's) are not applicable to surge brake systems and should not be used on Four Winns trailers.

DO NOT use a trailer hitch with moving parts. The brakes could activate when traveling downhill. Always use a fixed hitch.

Latch lever must be in open position to remove from or place on ball.

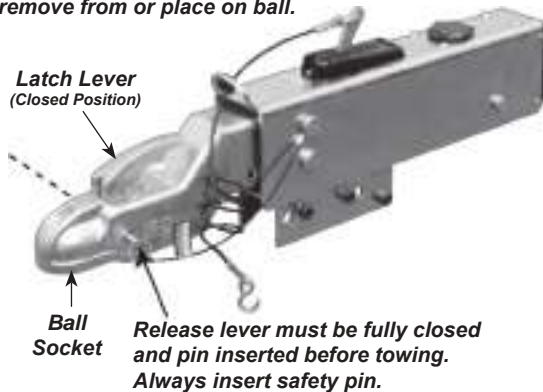


Figure S5: Brake Actuator & Coupling Assembly

The brake actuator and coupling assembly comes with a 5-wire plug for connecting to the tow vehicle's trailering harness. Figure S6 depicts the 5-wire plug, the color of the individual wires, and the designated circuit for each wire.



Figure S6: 5-Wire Plug Harness

For maintenance and other information, refer to the manufacturer's literature included with in the owner's packet.

## E. Winch

Winch operating instructions are listed below.

To release the winch, place the ratchet in the REVERSE or NEUTRAL position. The winch handle may spin when pulling on the winch line.

## CAUTION

To prevent personal injury, observe the following:

A spinning winch handle can cause injury. Be sure the area is clear.

DO NOT release the handle when the ratchet is disengaged. Be sure the ratchet is engaged or no load is on the winch before releasing the handle.

## CAUTION

To prevent personal injury, ALWAYS inspect the winch line and hook before each use. NEVER use line that is worn or frayed. NEVER let anyone stand in or behind a boat while pulling with the winch.

To rewind the winch, ALWAYS engage the ratchet first. Turn the handle in the appropriate direction to rewind the line.

## CAUTION

A clicking sound will be heard when the winch is properly engaged. If a clicking sound is not heard, DO NOT release the handle. Handle may spin backwards. Lower the load into a safe position before releasing the handle.

Refer to the manufacturer's literature, included in the owner's packet, for more information on winch operation.

## F. Tires & Wheels

The tires installed on Four Winns trailers meet the trailer load requirements for each model. Before trailering, make sure the tires are inflated according to the manufacturer's recommendation. Tire pressure information is noted on the tire and in the manufacturer's literature included in the owner's packet. Also refer to Section S-7 - "Supplemental Trailer Information" for additional information.



**NOTICE**

*DO NOT use an air wrench or other power equipment to install lug nuts on aluminum (Mag) wheels. Damage to the wheel may result. Lug nuts should be torqued to 90-110 foot pounds.*

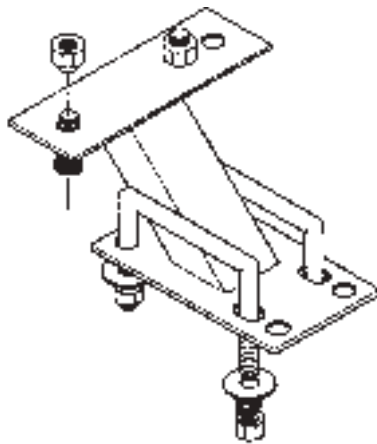
Examine the tires frequently for snags, bulges, excessive tread wear, separations or cuts. Refer to the manufacturer's literature included in the owner's packet for more information.

**NOTICE**

*The warranty of the tire is administered by the manufacturer of the tire. Contact the tire manufacturer regarding any warranty concerns relating to your tires.*

**G. Spare Tire Carrier**

Spare tires are optional on all Four Winns trailers. A spare tire carrier is bolted to the trailer frame and is available in painted or GatorHyde™ finish. A spare tire carrier and wheel can be ordered from your Four Winns dealer. Refer to Figure S7.



**Figure S7: Spare Tire Carrier**

**H. Lights**

Four Winns trailers are equipped with taillights, brake lights, turning signals, and clearance lights. All lights are sealed to prevent moisture from entering. The taillight assemblies may be replaced. The LEDs of the taillight are also enclosed in a sealed housing which should not be opened. See Figure S8. Contact your Four Winns dealer for assistance should replacement be necessary.



**Figure S8: Tail Light - LED**

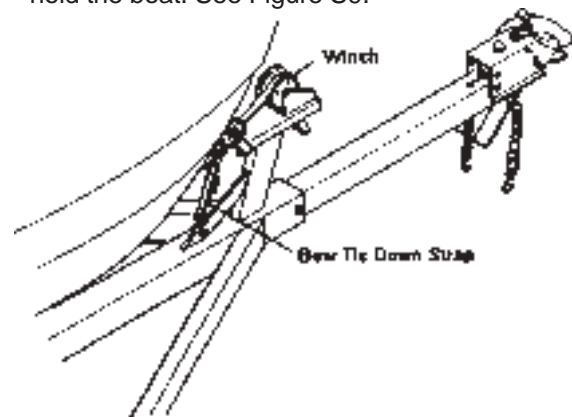
Consult your dealer for state trailer regulations concerning lighting and other optional equipment.

**I. Tie-downs**

The boat should be secured to the trailer by tie-downs to prevent damage to the hull. The boat may shift or bounce against the bunks or hull supports if not secured. It may also slide or fall off the trailer while being towed.

There are two types of tie-downs being used:

1. Bow Tie-downs: A bow stop to hold the front of your boat in place is located on the winch stand. It should be positioned so that the winch line pulls straight and is parallel to the trailer frame. A separate tie-down should then be attached to hold the boat. See Figure S9.



**Figure S9: Bow Tie Down Strap**

**NOTICE**

*DO NOT rely on the winch cable (or line) alone to hold the bow of the boat against the bow stop. A bow tie-down is provided with the Four Winns trailer.*

2. **Rear Tie-downs:** It is very important that the transom is resting centered, securely on the bunk supports at the rear of the trailer. On some models rear tie-downs are attached to the trailer and used to secure the boat to the trailer. Tighten the tie-downs to prevent the boat from moving. See Figure S10.



**Figure S10: Rear Tie Down Straps**

The **bow tie-down** is a mechanical ratchet device. To allow the strap out, follow the procedures below:

1. Place two fingers on spring-loaded release, and pull release away from spindle/gear.
2. Open tie-down to a flat, 180° position.

**NOTICE**

*Spring-loaded release should click into a notch on the handle. Both spring releases should clear the inner gear.*

3. Pull strap out. The inner spindle/gear should move freely.

To ratchet strap or tighten down the strap on the boat:

1. Place two fingers on spring-loaded release, and pull release away from spindle/gear.
2. Bring both handles together. Both handles should ride on the inner gear.
3. Open (to approximately 110°) and close handles to ratchet. Leave in closed position to maintain pressure on strap.

The **rear tie-down straps** are also a mechanical ratchet devices. To allow the strap out, follow the procedures below:

1. Place two fingers on spring-loaded release and push release downward while pushing the handle forward towards the trailer. See Figure S11.



**Figure S11: Rear Tie Down Strap - Release**

2. With other hand, pull strap upward. The inner spindle/gear should move freely.

To ratchet strap or tighten down the strap on the boat:

1. Place hand on handle and lift upward and away from trailer until the spindle/gear locks and handle stops.
2. Return handle to start position and repeat step one. Continue until strap has been sufficiently tightened. See Figure S12.



**Figure S12: Rear Tie Down Strap - Tightening**

## S - 3 OPERATION

### A. Hitching Trailer

Before towing, the trailer must be properly hitched to the tow vehicle.

#### **WARNING**

To ensure proper engagement of the actuator's coupler to the tow ball, **DO NOT** use a multi-piece ball, an incorrectly sized ball, or a worn/damaged ball. Please refer to the trailer's certification plate, coupler or actuator on the trailer for Gross Vehicle Weight Rating (GVWR) or visit our website at [www.fourwinns.com](http://www.fourwinns.com). Trailers with a GVWR of 7000 pounds or below require a 2" tow ball and trailers above a GVWR of 7000 pounds require a 2 5/16" tow ball.

1. Position actuator ball socket above ball hitch. Note that the actuator's emergency stop is not engaged. To manually release the emergency stop refer to Step 8.
2. Open the coupler latch fully to allow the ball latch to rotate open. Note: You will have to remove the safety pin from the coupler latch hole to fully extend the coupler latch lever. The latch lever will remain up to indicate that it is not yet attached to the ball.
3. Lower trailer tongue until ball is seated or rests in ball socket completely. Ensure the ball latch is in the correct position to retain the hitch ball.
4. Close coupler latch by pushing latch down until latch engages properly.

The coupler latch lever should close and secure freely with finger pressure when ball is properly seated in the ball socket. **If the coupler latch does not close freely or does not engage properly, do not tow trailer. DO NOT** force the coupler latch into closed position, otherwise damage could result. Inspect actuator for bent parts or cause of improper operation.

#### **NOTICE**

*Keep the coupler clean and lubricated to prevent damage to the coupler.*

5. Make sure the actuator is secure. If unsure, extend the trailer tongue jack to the ground and lift (with the jack) the vehicle and trailer combination approximately 2" to 4". If the ball does not disengage and remains secured, the actuator is latched properly.

#### **NOTICE**

*To prevent back injury, DO NOT physically lift the trailer tongue when loaded.*

6. The safety pin, provided with the trailer, or a padlock **must be inserted completely** in the coupler latch hole. This ensures the coupler's locking latch remains in the locked position during towing of the trailer. Use of a padlock will help to deter theft.

7. Connect actuator break-away cable S-hook securely to one of the tow vehicle hitch's safety chain connection points. Do not connect S-hook to the safety cables or chains. The cable should hang clear of trailer tongue and be long enough to permit short radius turns without pulling the break-away cable. **DO NOT** loop the break-away cable around a bracket and loop it back onto itself.
  
8. If the break-away system is accidentally applied while unhitching, following the manufacturer's instructions, insert a flat bladed screwdriver under the steel spring plate and push the handle of the screwdriver down, prying up the spring plate up to release the E-stop lever. See Figures S13 - S16.



**Figure S15: Pry Up w/ Screwdriver on Spring Plate**



**Figure S13: Emergency Break-Away Normal & Engaged**



**Figure S16: Emergency Break-Away Normal Position**



**Figure S14: Emergency Break-Away Spring Plate**

**NOTICE**

*E-stop lever should move freely after release.*

 **WARNING**

*When resetting the break-away system keep hands and fingers clear as you reset the mechanism. Hydraulic pressure held in the system may cause the assembly to snap back suddenly.*

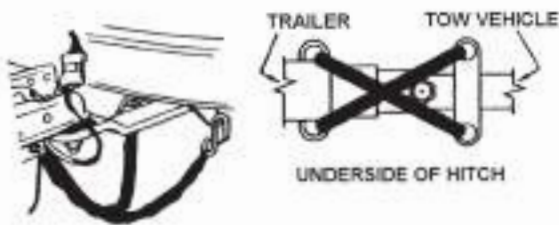
**CAUTION**

The break-away system is not designed to operate if the trailer does not separate completely from the tow vehicle, or if the trailer tongue “submarines” and goes beneath the tow vehicle. **DO NOT** use break-away cable as a parking brake.

- Safety cables are provided and must be used. Cross the safety cables under the coupling and attach to the towing vehicle’s frame or bumper. See Figure S17. Always allow slack for turns. Regulations vary from state to state. Please check the local laws in your state.

**WARNING**

The trailer’s safety cable length **MUST** be set short enough so the actuator’s break-away cable is **NOT** pulled if the coupler separates from the tow vehicle’s hitch but remains connected by the safety cables. The break-away system should only be activated after **BOTH** the trailer’s coupler and safety cables have failed and allowed the trailer to completely separate from the tow vehicle. Provide just enough slack in the trailer safety cables to allow short radius turns. The cables should not drag on the ground. **Safety cables must be used.**



**Figure S17: Crossing the Safety Cables**

**WARNING**

To reduce the risk of break-away accidents, be sure coupler is seated and safety cables are crisscrossed before trailering.

- Retract jack fully and place in trailering/horizontal position.

- Check for proper tow vehicle-trailer hookup. The tow vehicle and trailer should be level with a positive tongue load. Four Winns trailers are designed with tongue weights between 7% and 11% of the total weight of the boat, fuel, gear and trailer. The trailer should be close to level. If unsure of tongue load and trailer position, consult your Four Winns dealer before proceeding.

**WARNING**

Be sure the tow vehicle and trailer are level and have a positive tongue load. This will allow the brake actuators to function properly on trailer models having such braking systems.

Be sure to read the manufacturer’s literature, included in the owner’s packet, before towing your Four Winns boat and trailer.

**B. Backing Up With Surge Brakes**

Follow the steps listed above for hitching the trailer before backing up.

- Before backing up a slope or through soft ground, pull the trailer forward slightly to assure the actuator socket is in the fully forward position.
- Back the trailer up.

**CAUTION**

Avoid sharp turns. This could bend, create extreme stress or fracture either the actuator or trailer tongue.

**NOTICE**

Be sure to check for obstacles or persons behind the trailer before backing up. Also, adjust your mirrors for clear view of the area behind the trailer.

- If the trailer is to be uncoupled from the tow vehicle after backing, block all trailer wheels and pull forward slightly to take strain off the actuator. Uncouple the actuator by lifting the release handle and raise the trailer tongue with the jack.

For most trailering conditions, the brake actuator will allow you to back up normally using a 5-wire harness connector. However, if the coupler is not wired or if there is a failure the trailer can still be backed up by using the manual brake lockout.

To use the manual brake lockout, check that no force is being applied to the actuator. This is achieved by positioning the towing vehicle and the trailer on a flat service, or with the trailer downhill from the tow vehicle. Set the vehicle's parking brake.

Insert a 7/16" x 5" bolt or screwdriver into the reverse lockout position hole (upper hole on side of actuator). This will then block movement of the actuator. See Figure S18. Reverse lockout option must only be used when moving in reverse and when braking is not required. Immediately remove bolt or screwdriver prior to towing after backing up is completed.

#### NOTICE

*The reverse lockout position hole and actuator hole may not be in alignment. You may have to block the trailer's wheels and pull the trailer forward enough so the holes are aligned and a bolt or screwdriver may be inserted completely into the reverse lockout position holes.*

**Reverse Lockout Hole Location**  
(See the following warning.)



**Figure S18: Reverse Manual Brake Lockout Hole Location**

#### WARNING

**Never allow the bolt or screwdriver to remain in the reverse lockout position hole.** After reverse maneuvering, always remove bolt or screwdriver from the reverse lockout position hole. Failure to remove bolt or screwdriver from reverse lockout position hole will prevent forward movement braking which can result in serious property damage, injury or death.

#### NOTICE

*Trailer components may be different between models and may change during the model year. Be sure to read all manufacturer's literature supplied with your Four Winns trailer.*

## S - 4 TRAILERING

### A. Checklist

Before trailering, the trailer should be inspected for the following:

1. Check tires for proper inflation. Under-inflated tires heat up rapidly and may blowout or cause uncontrolled swaying.
2. Check lug nuts for proper tightness (90-110 ft-lbs).
3. Be sure the coupler is secured to the trailer hitch and safety cables are attached.
4. Be sure trailer taillights and turning signals are operational.
5. Check the brakes for proper operation prior to departure.
6. Check tie-downs and make sure boat is secured to the trailer.
7. Check the springs and under carriage for loose parts.
8. Before towing, close and secure all hatches, doors, and windows. Securely store all equipment and canvas. Installed tops, side curtains, and aft curtains can be damaged while towing.

9. Carry a spare tire for both the trailer and towing vehicle. On extended trips, carry spare wheel bearings, seals, and races. Be sure and carry the proper tools to complete the repairs.



*To avoid bearing failure and possible wheel loss, keep wheel bearings properly lubricated. Inspect the wheel bearings periodically and check for damage.*

10. Before trailering, inspect the bearings for wear and adequate lubrication. When traveling, check the wheel hubs during stops at gas stations, restaurants or other places. If the hub feels abnormally hot, the bearing should be inspected before continuing the trip.

## B. Tactics

### NOTICE

*Be sure to check the towing vehicle manufacturer's literature for recommendations on towing.*

1. Install outside rear view mirrors on both sides of the towing vehicle to improve vision. Check the rear view mirrors at frequent intervals to be sure trailer and boat are riding smoothly.
2. Allow at least one car and trailer length between vehicles for each 10 mph. **DO NOT** tailgate.
3. Use low gear (on manual transmissions) when traveling up steep hills or over sand, gravel, or dirt roads.
4. Use care if shifting to a lower gear while traveling downhill. This could activate the trailer's surge brakes for the duration of the downhill run and cause overheating. Extended overheating could result in complete loss of the trailer brakes.

To help prevent overheating, slow down while approaching the crest of a hill and maintain a slow, controlled downhill speed. Apply brakes in short intervals to allow time between braking for the brakes to cool off.

5. When rounding turns on highways or streets, **DO NOT** cut corners. Also, travel slowly over railroad tracks.
6. If the trailer begins to "fishtail" when accelerating, reduce speed until it ceases. If the trailer "fishtails" again during acceleration, stop to investigate the cause of the problem. Check for improper trailer load and uneven weight distribution inside the boat. Check the winch line and tie-downs. Also check the tires for proper inflation or damage. If necessary, redistribute the load before continuing.

For additional information on trailering, refer to the "Boating Basics" manual included in the owner's packet.

## S - 5 MAINTENANCE

### A. Care of Exterior Finish

When using the trailer, keep in mind the paint can scratch and become marred during normal use. In most cases, touch-up paint can be ordered. Please contact a Four Winns dealer for assistance.

Some maintenance is required to maintain the finish and minimize rusting. The trailer should be washed and rinsed with clean water immediately after each use. Depending upon use, waxing is recommended twice a year. Use paste wax designed for enamel paint.

On trailers with GatorHyde™, rinse all exposed metal parts thoroughly with only clean water after use. The GatorHyde™ protective coating may be cleaned with mild dishwashing soap in a bucket of water along with a nylon boat brush. Rinse thoroughly with clean water.

To rejuvenate as well as UV protect worn and faded GatorHyde™ you may purchase a product called GatorGloss™. To place an order you can phone Elastomer Specialties, Inc. at 918-485-2835 or Fax 918-485-2856.

### B. Bunks

The bunks should be replaced if they are cracked, warped, or evidence of dry-rot is found. The replacement boards should be treated lumber of the same length and width. Re-carpet bunks with high quality exterior grade carpet.

 **CAUTION**

*DO NOT burn damaged or broken bunks. Toxic fumes will be released. Dispose of bunks properly.*

### C. Swivel Jack

Keep the swivel jack clean of dirt, tar, and mud. Lubricate every six months. The swivel jack's inner ram should be lubricated with SAE 30 weight oil. The top cover may be removed to lubricate the gears with wheel bearing grease.

Replace all worn and damaged parts. ALWAYS use the manufacturer's replacement parts. Replacement parts may be ordered through your Four Winns dealer.

For more information on maintenance, refer to the manufacturer's literature included in the owner's packet.

### D. Brake Actuator & Coupling Assembly

When storing or parking your trailer, keep the brake actuator and coupling assembly (coupler) off the ground to prevent dirt buildup in the ball socket. Keep the coupler clean of dirt, tar, and mud. Lubricate the coupler with SAE 30 weight oil every six months or as often as necessary. Replace any worn or defective parts. If the coupler is damaged, contact your Four Winns dealer for replacement parts. DO NOT use a damaged or bent coupler assembly.

For more information on maintenance, refer to the manufacturer's literature included in the owner's packet.

**NOTICE**

*The trailer should be set up at a slight angle to allow for water to drain aft in the boat.*

### E. Winch

The winch should be kept clean of dirt, ice, paint, etc., and the spur gears should have a film of grease on them at all times. Apply several drops of SAE 30 weight oil to the ratchet pawl mechanism, bushings and pinion shaft threads twice per season.

Replace any worn or damaged parts. For more information on maintenance, refer to the manufacturer's literature included in the owner's packet.

### F. Lights

Inspect wiring for cuts or bare wire which could cause electrical shorts. Repair or replace defective wiring. Replace cracked or damaged lights and always carry spare bulbs if applicable. Replacement parts may be ordered through a Four Winns dealer.

### G. Tie-downs

Replace frayed or damaged tie-downs. Periodically, lubricate the ratchet mechanism with a fine oil or silicone spray. Replacement parts may be ordered through a Four Winns dealer.

### H. Wheels

Some maintenance is required to maintain the finish of the rims. Chrome wheel rims may be cleaned with dishwashing soap and water. Also, there are cleaning products specifically for chrome that can be used. Cleaners may be obtained from Four Winns dealers and your local auto parts stores. The aluminum wheel manufacturer recommends a product by Priority One® called Pro-Long Aluminum/Chrome Wheel Protectant™. Galvanized rims should be rinsed only with clean water immediately after each use.

**NOTICE**

*ALWAYS read the manufacturer's instructions on the label before using any product.*

### I. Brakes

Keep the actuator clean of dirt, tar, and mud. The actuator and internal parts should be lubricated at all times with SAE 30 weight oil. The hitch ball may be lubricated with automotive grease or lubricant made for hitch balls.

Periodically inspect the brake system for leaks. Check all hoses for cuts or wear. Replace all defective hoses. The master cylinder should be filled within 1/2 inch from the top of the reservoir.

At the beginning of each year, inspect the brakes for excessive wear, have linings replaced if necessary. If the brakes need bleeding, consult your Four Winns



dealer for assistance. If unavailable, a brake or auto repair facility can perform the repair.

Refer to the manufacturer's literature included in the owner's packet for additional information on the brake system.

## J. Bearings

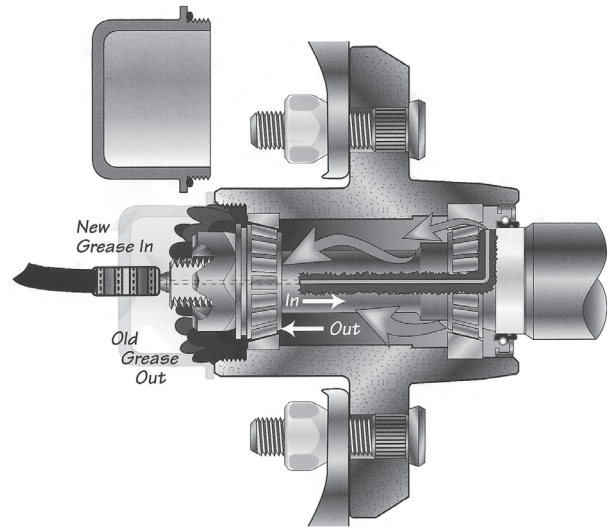
Wheel bearings and seals should be inspected at the same time as brakes. Have worn or defective parts replaced.

The Four Winns trailer is equipped with Vortex hubs/spindles from Tie Down Engineering and the information which follows comes from the manufacturer's literature. The hubs are pre-grease and assembled at the factory and should not require any additional adjustments. See Figure S19.



**Figure S19: Vortex Hub**

Should the hub/bearings require additional lubrication for any reason, the Vortex lubrication system allows you to do so without removing the hub or having to re-adjust the bearings. New Lucas Oil Marine grease is pumped into the zerc fitting at the end of the spindle, travels to the rear bearing where the new grease pushes out the old grease through the rear bearing, center of hub, and then through the front bearing. See Figure S20.



**Figure F20: Vortex Lubrication System  
(Adding Grease)**

To add or change Lucas Oil Marine grease in the Vortex hub follow these steps:

1. Remove the Vortex grease cap, unscrewing in a counterclockwise rotation.
2. Use a standard grease gun loaded with Lucas Oil marine grease to pump grease into the zerc fitting located on the end of the spindle.
3. Pump the Lucas Oil Marine grease into the zerc fitting while slowly rotating the wheel. Grease will flow out of the hub around the front bearing.
4. When the grease appears to be the new clean grease, remove the grease gun.
5. Replace the Vortex grease cap. Turn in a clockwise rotation until the o-ring on the cap is in contact with the hub surface. Turn an additional 1/4 turn to seal the Vortex cap to the hub. (This is similar to installing an oil filter in an automobile).

### NOTICE

*To maintain the factory warranty, Lucas Oil Marine grease must be used when adding or replacing grease in the vortex hub.*

**NOTICE**

*Most bearing failures are due to improper maintenance. Be sure to inspect bearings and seals as noted in Section S-6B and refer to the manufacturer's literature included with your trailer.*

**S - 6 AXLE INSPECTION & REPAIRS**

As a general rule, repairs and maintenance should be performed by qualified servicing personnel. Our axle manufacturer recommends that a certified mechanic should be consulted on the following items:

1. Broken axle
2. Broken spring
3. Worn spring eye bushing parts
4. Sagging springs
5. Welding fatigue
6. Serious leakage of seal
7. Tire wear
8. Loose or worn suspension parts
9. All brake related adjustments, inspections and problems

 **CAUTION**

*Removing the Vortex Hub for inspection or maintenance should be done in a safe location away from moving vehicles.*

**A. Removal of Hub**

The following instructions pertain only to trailers manufactured by Four Winns. To remove the hub to inspect the bearings and seals, refer to Figure S21 and the following instructions:



**Figure S21: Axle Components**

1. Elevate the trailer on level ground using the manufacturer's instructions. Always use jack stands or other solid supports. Do not rely on a jack to support the trailer. Block wheels to keep the trailer from rolling.

2. Remove the tire/wheel assembly.
3. Place a newspaper or cloth on the ground under the hub to keep any parts from falling onto a dirty surface.
4. Remove the Vortex grease cap by unscrewing in a counter clockwise rotation.
5. Remove the cotter pin, castle nut (in a counter-clockwise rotation) and washer.
6. Remove the hub from the spindle. If you have disc brakes, you will need to remove the brake caliper to remove the rotor. Follow separate instructions for disc brake rotor removal.
7. Be careful not to allow the bearings to fall out of the hub.
8. Clean bearing and cup surfaces.

**B. Bearing/Seal Inspection and Replacement**

When inspecting bearings or seals:

1. Inspect the grease seal for damage, tears, or cracks. If there is no damage or leakage is not occurring, the seal is in good condition.

If the seal is torn or cracked, then it should be replaced. The seal can be pried out of the hub with a screw driver. Be sure to replace the seal using the recommended replacement parts. Parts can be obtained from your Four Winns dealer.

2. When inspecting the bearing, check for corrosion and wear. If any rust or wear exists on the bearing, then remove and replace with the manufacturer's recommended part.
3. If the bearings are in good condition, repacking the grease should be done at this time. Hand pack each bearing individually using a premium water-resistant wheel bearing grease.

**NOTICE**

*To maintain the factory warranty, Lucas Oil Marine grease must be used when adding or replacing grease in the vortex hub.*

### C. Hub Reinstallation

1. To re-install, coat bearings with Lucas Oil Marine Grease before re-installing.
2. Install bearings and place hub on spindle in reverse order as listed in the Section S-6A - "Removal of Hub". Rotate the hub while applying approximately 50 ft. lbs. of torque to the spindle nut. This translates into a full hand pressure load with a 12" long wrench. This "seats" the bearings.
3. Loosen the spindle nut to remove the torque applied. **DO NOT ROTATE THE HUB.**
4. Tighten the spindle nut until snug, backing off only enough to line up the cotter pin with the hole in the spindle.
5. Bend the cotter pin into place.
6. Load hub with "Lucas Oil Marine" grease using the instructions for adding or changing grease Section S-5J - "Bearings" and/or manufacturer's Literature.
7. Replace the Vortex grease cap. Turn in a clockwise rotation until the o-ring on the cap comes in contact with the hub surface. Turn an additional 1/4 turn to seal the Vortex cap to the hub. (This is similar to installing an oil filter in an automobile).
8. Replace tire/wheel, torque lug nuts according to wheel manufacturer's instructions.
9. Test hub for proper end play by grabbing the tire and pulling the tire from side to side. Readjust if necessary.

**NOTICE:  
IMPORTANT**

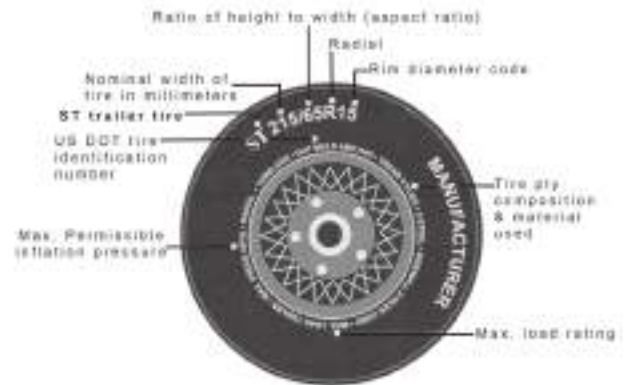
Re-check lug nuts after 25 miles of use.

Refer to Sections S-2F and the S-7 for additional information.

### S - 7 SUPPLEMENTAL TRAILER INFORMATION

#### A. Information Contained on Sidewall of the Tire

Both U.S. and Canada Federal regulations require tire manufacturers to place standardized information on the sidewall of all tires. This information identifies and describes the characteristics of the tire. See Figure S22.



**Figure S22: Axle Components**

**Maximum Permissible Inflation Pressure:** Indicates the tire manufacturer's maximum permissible pressure and/or the pressure at which the maximum load can be carried by the tire. Refer to the Certification Label on the port forward half of the trailer for the correct tire pressure for your trailer.

**U.S. DOT Tire Identification Number (TIN):** This begins with the letters 'DOT' and indicates the tire meets all federal standards. The next two numbers or letters are the plant code designating where it was manufactured, the next two are the tire size code, and the last four numbers represent the week and year the tire was built. For example, the numbers 5110 mean the tire was built the 51st week of 2010. The numbers are identification codes used for traceability. This information is used to contact customers if a tire defect requires a recall.

**ST:** Indicates the tire is a special tire for trailers in highway service.

**215:** Indicates the nominal width of the tire in millimeters from sidewall edge to sidewall edge. In general, the larger the number, the wider the tire will be.  
**65:** Indicates the aspect ratio which gives the tire's ratio of height to width.

**R:** Indicates a "radial" type tire.

15: Indicates the wheel or rim diameter in inches. Tire Ply Composition and Materials Used: Indicates the number of plies or the number of rubber-coated fabric in the tire tread and sidewall. Tire manufacturers also must indicate the ply materials in the tire and the sidewall, which include steel nylon, polyester, and others.

Maximum Load Rating: Indicates the maximum load in kilograms and pounds that can be carried by the tire. Refer to the Certification Label on the port forward half of the trailer for the correct tire pressure for your trailer.

### B. Sample Tire Registration

**NOTICE:**

*Manufacturer's Tire Registry: Be sure to fill out the tire registration form provided with your owner's packet. Mail it to the tire manufacturer for the purpose of Federal Defect Notification Regulations. See Figure S23.*

**IMPORTANT**

In case of a recall, we can reach you only if we have your name and address. You MUST send in this card to us on **YOUR** TAG.

Do it today!

SHADED AREAS MUST BE FILLED IN BY BUYER

OWNER'S NAME (PRINT)		TIRE BRAND	
NAME OF BUYER (PRINT)	STATE	TYPE	SIZE
ADDRESS			
CITY	STATE	ZIP CODE	
PHONE NUMBER			
DATE OF PURCHASE			
DEALER NAME			

Figure S23: Sample Tire Registration Form

### C. Inflating Your Tires

Safe operation of your trailer requires that your tires are properly inflated. Remember that a tire can lose up to half of its air pressure without appearing flat. Before each trip, check your tires with a tire gauge, including the spare (if equipped). Inflate all tires to the inflation pressure recommended on the Tire Label and/or on the Certification Label located on the port side of the forward half of the trailer. See Figures S24 & S25. These labels are located on the port side of the forward half of the trailer. Failure to follow the tire pressure recommendations can cause uneven tread wear patterns and adversely affect the way your trailer handles.



Figure S24: Tire Label (Sample) (Tire Pressures May Vary)

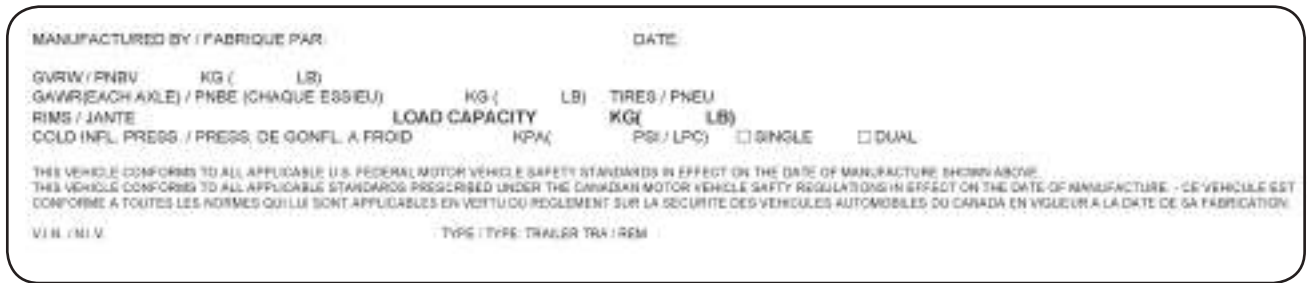
When weather temperature changes occur, tire inflation pressures also change. A 10° F (6° C) temperature drop can cause a corresponding drop of 1 psi (7 kPa) in inflation pressure.

**NOTICE:**

*Under-inflation is the most common cause of tire failures and may result in severe tire cracking, tread separation or "blowout", with unexpected loss of vehicle control and increased risk of injury. Under-inflation increases sidewall flexing and rolling resistance, resulting in heat buildup and internal damage to the tire. It also may result in unnecessary tire stress, irregular wear, loss of vehicle control and accidents. A tire can lose up to half its air pressure and not appear flat!*

To check the pressure in your tire(s):

- 1: Check your tire(s) when they are "cold". The term cold does not relate to the outside temperature. Rather, a cold tire is one that has not been driven for at least three hours. When you drive, your tires get warmer, causing the air pressure to increase. Therefore, to get an accurate tire pressure reading, you must measure the tire pressure when the tires are cold or compensate for the extra pressure in warm tires.
- 2: Remove the cap from the valve on one tire, then firmly press the tire gauge onto the valve and measure the pressure with the tire gauge.
- 3: Add (or remove) enough air to reach the recommended air pressure indicated on your Certification Label and or Tire Label. See Figures S24-S25.



**Figure S25: Certification Label (Sample)**

4: Replace the valve cap.

5: Repeat this procedure for each tire, including the spare.

**Tire Care:**

Periodically inspect the tire treads for uneven or excessive wear and remove objects such as stones, nails, or glass that may be wedged in the tire grooves. Check for holes or cuts that may permit air leakage from the tire and make necessary repairs. Also inspect the tire sidewalls for cracking, cuts, bulges, and other signs of damage or excessive wear. If internal damage to the tire is suspected, have the tire removed and inspected in case it needs to be repaired or replaced. For your safety, tires that are damaged or show signs of excessive wear should not be used because they are more likely to blow out or fail. Improper or inadequate trailer maintenance can cause tires to wear abnormally. Inspect your tires, including the spare frequently, and replace them if one or more show signs of damage or excessive wear.

**NOTICE:  
AGE**

*Tires degrade over time, even when they are not being used. It is recommended the tires generally be replaced after 6 years of normal service. Heat caused by hot climates or frequent high loading conditions can accelerate the aging process. You should replace the spare tire when you replace the other tires due to the aging of the spare tire.*

**D. Load Carrying Capacity**

The certification label shows the maximum load-carrying capacity and is located on the port forward inside of the trailer. See Figure S25.

GVWR is the Gross Vehicle Weight Rating. It is the total combined weight of the trailer and its maximum load-carrying capacity. **DO NOT** exceed the GVWR rating for the trailer.

Total Load is the maximum load-carrying capacity of the trailer minus the weight of the trailer.

Locate the statement “Total load should never exceed XXX kg or XXX lbs.” on your trailers tire label located on the port forward side of your trailer.

This figure equals the available amount of the boat with all equipment, gear, fuel, water, and luggage load capacity.

Determine the combined weight of the boat with all equipment, gear, fuel, water, and luggage being loaded on the trailer. That weight may not safely exceed the tire labels total load.

Improper weight distribution can place excessive strain on the towing vehicle and trailer. It can also cause the trailer to “fishtail” (sway side to side). Be sure gear and luggage are distributed evenly in the boat.

**E. Reporting Safety Defects**

If you believe that your vehicle has a defect which could cause a crash or could cause injury or death, you should immediately inform the National Highway Traffic Safety Administration (NHTSA) in addition to notifying (INSERT NAME OF MANUFACTURER).

If NHTSA receives similar complaints, it may open an investigation, and if it finds that a safety defect exists in a group of vehicles, it may order a recall and remedy campaign. However, NHTSA cannot become involved in individual problems between you, your dealer, or (INSERT NAME OF MANUFACTURER).

To contact NHTSA, you may call the Vehicle Safety Hotline toll-free at 1-888-327-4236 (TTY: 1-800-424-9153); go to <http://nhtsa.safercar.gov>; or write to: Administrator, NHTSA, 1200 New Jersey Avenue SE, Washington, DC 20590. You can also obtain other information about motor vehicle safety from <http://www.safercar.gov>.

## **F. Glossary of Tire Terminology**

**Tire label:** A label showing the tire sizes, recommended inflation pressure, and the maximum weight the trailer can carry.

**Tire Identification Number (TIN):** A number on the sidewall of each tire providing information about the tire brand, manufacturing plant, tire size, and date of manufacture. It is also referred as the DOT code.

**Inflation pressure:** A measure of the amount of air in a tire.

**kPa:** Kilopascal, a metric unit of air pressure.  
**PSI:** Pounds per square inch, a standard unit of air pressure.

**Cold tire pressure:** The tire pressure when the trailer has been stationary and out of direct sunlight for an hour or more and prior to the trailer being pulled 1 mile (1.6 km)

**Recommended inflation pressure:** The cold inflation pressure found on the certification label or tire label located on the port forward side of the trailer.

**Bead area of the tire:** Area of the tire next to the rim.

**Sidewall of the tire:** Area between the bead area and the tread.

**Tread area of the tire:** Area of the perimeter of the tire that contacts the road when mounted on the trailer.

**Rim:** The metal support (wheel) for a tire upon which the tire beads are seated.



**T - 1 LAUNCH AND CRUISE CHECKLIST**

- Get a current weather report. If the weather will not be favorable, postpone your trip.
- If your boat has been out of the water, check to see that all bilge water has drained out.
- Install hull drain plugs.
- Inspect the hull and propeller for damage. Excessive dirt or marine growth will effect your boat's performance and fuel efficiency.
- Check the electrical system and navigation lights.
- If your boat has been in the water, run the bilge pump until the flow of water stops.
- Check that all required safety equipment is on board and in good working condition. Examples include personal flotation devices (PFDs), horn, fire extinguisher, visual distress signals, etc. Take along extra drinking water.
- Check that other important equipment is on board. Examples include mooring lines, anchor and line, tool kit, first aid kit, etc.
- Open engine compartment. Inspect for fuel odors and visible leaks in the fuel, oil, coolant, exhaust and power steering systems.
- Visually inspect engine for cracked hose, defective belts, or other signs of engine problems. Check engine oil and battery water levels. Check power steering fluid level. Check battery electrolyte range.
- Check fuel level. Fuel tanks should be filled to slightly less than capacity. Allow for fuel expansion.
- Check that all engine drains are closed (stern drives).
- Make sure navigation charts and equipment are on board.
- Check operation of steering system, navigation lights, and operation of horn.
- Make sure passengers and crew know what to do in case of an emergency and how to operate safety equipment.
- Make sure all required documents are on board.
- File a float plan with a responsible party ashore.
- Keep an eye on the weather. Be aware of possible changing conditions by monitoring local weather broadcasts prior to departure. The captain or first mate should personally monitor strong winds and electrical storms.
- Always keep accurate up-to-date charts of your boating area on board.

## T - 2 FUELING



*Do not smoke, extinguish all open flames, STOP all engines and other devices that could cause sparks, including the bilge blower. Do not use electrical switches or accessories. Shut OFF all stoves that may produce a spark or flame. Close all openings into the cabin area of the boat.*

### A. Recommendations



*When fueling or having your boat fueled by an attendant, be sure the waste pump-out or fresh water fitting is not mistaken for the fuel fill.*

The fuel system components used by Four Winns® will withstand up to 10% alcohol content in the gasoline (not applicable to diesel engines). Although alcohol boosts the octane level of gasoline, it also attacks the rubber fuel distribution lines and even metal fuel system components. Alcohol will permeate most fuel hoses and other components such as fuel pump, gaskets and seals, and can also contribute to fuel system contamination.

The hoses we use in our boats are alcohol-resistant as are the materials used by the engine manufacturers. If only fuel containing alcohol is available, or the presence of alcohol is unknown, you must perform more frequent inspections for leaks and abnormalities. Any sign of leakage or deterioration requires your immediate attention. Refer to the engine manufacturer's recommendations on fuel type and octane ratings.

### B. Preliminary Guidelines

1. Safely secure your boat to the dock.
2. Close all hatches, windows, doors and compartments to prevent accumulation of fuel vapors.
3. Ensure that a fire extinguisher is readily available.
4. Do not store fuel in areas that are not adequately ventilated.
5. Use only fuel lubricants recommended by the engine manufacturer.

## C. Pumping Fuel



*Follow engine manufacturer's recommendations for types of fuel and oil. Use of improper products can damage the engine and void the warranty.*

1. Be sure to fuel in a well-lit area. Fuel spills are unnoticeable under poor lighting or in the dark.
2. Remove the fuel fill cover.
3. Insert the fuel supply nozzle, keeping it in contact with the fuel fill plate to guard against static produced sparks.
4. Stand away from the fuel tank vent and gas fill during fueling. Splash back may occur and can be an eye irritant and/or a fire hazard.
5. Avoid spillage. Wipe up any excess fuel immediately.
6. After pumping approximately 10 gallons of fuel into the fuel tank, inspect the engine and fuel tank area for any signs of leakage. If no leaks or other problems are detected, resume fueling.
7. Allow space at the top of the tank for thermal expansion.
8. If fuel cannot be pumped in at a reasonable rate, check for fuel vent blockage or a kink in the line.

### D. After Fueling

1. Replace the fuel fill cover and wipe up any fuel spilled. Discard rags used in a safe place ashore.
2. Open the engine compartment and all hatches, windows, doors and other compartments that were closed during fueling. Inspect these areas for the odor of fuel vapors and visible fuel leakage.



*Investigate and correct any sign of fuel leakage or indication of vapors before starting engine. Do not run blower or operate any electrical switch until problem is corrected. Fire or explosion may result.*



### T - 3 LOADING PASSENGERS AND GEAR

When loading your boat, remember to distribute the load evenly. Keep the load low and do not overload. Position passengers and gear so that the load is balanced.

#### NOTICE

*The NMMA Yacht Certification rating (indicated by a yacht certification plate - see Preface page 14) places the responsibility on the captain to make the determination as to the appropriate load, load placement and number of passengers permitted aboard the vessel.*

When loading, always step into the boat, never board by jumping. Have someone on the dock pass your gear aboard. Secure all gear firmly so it doesn't move or interfere with operation of the boat. Passengers should board the boat one-at-a-time and be seated.

**IMPORTANT:** Passengers are prohibited from riding on the bow with feet hanging over the side or ride while sitting on the stern, gunwales or seat backs. The Coast Guard considers these acts to be negligent or grossly negligent operation. They are prohibited by law because falls from moving boats are a major cause of fatal recreational boating accidents.

**IMPORTANT:** The presence of the capacity plate does not relieve the boat operator from the responsibility of using common sense or sound judgment. Turbulent waters and adverse weather conditions will reduce the maximum load capacity rating of the boat.

### T - 4 STARTING PROCEDURES

The operation and maintenance manual supplied with your engine provides pre-start, starting and cold-starting instructions. The following information is merely a guide and not intended to explain in detail all starting procedures and instructions. Refer to your engine owner's manual and Section A of this manual.

#### A. Preliminary Checks

1. Secure boat to the dock before attempting to start engine. The boat should be kept secure until the engine is running and warmed up.
2. Operate the bilge pump until the flow of water stops.
3. Make sure the throttle is in the neutral position.
4. Check all electrical systems and navigation lights.

#### B. Starting



*To prevent excessive exposure and reduce the possibility of carbon monoxide accumulation in the cockpit areas of the boat, the operator should provide adequate ventilation in each of these areas. Utilize hatches, doors, windows and side vents to increase air movement. See Section B-2 for information about the dangers of Carbon Monoxide.*

**Notice:** Additional starting information is located in Section A.

#### 1. Starting Procedures for EFI Engines

- A. If your boat is equipped with a battery selector switch, turn the battery switch to I (ON), or COMBINED BATTERY (Emergency Start) position (positions may vary depending on which model you have).
- B. Attach the ignition interrupt lanyards securely to your body (if applicable). In the event that you move away from the helm area and beyond the length of the lanyard, the engine will be turned off.
- C. If your boat has fuel injection, turn the key to start the engine. Engine will not turn over if throttle is not in the neutral position.
- D. When engine is cold, run engine approximately one (1) to two (2) minutes at fast idle speed (1200 to 1500 rpm). This step is not necessary with fuel injected engines.
- E. Once engine has warmed up, check water temperature gauge to ensure engine temperature stays within optimum range. If temperature reading is abnormally high, stop engine immediately and inspect for cause of high reading.
- F. With engine running, voltmeter should show a reading between 12 and 15 volts.
- G. Check steering operation. Turn steering wheel full to port and starboard while observing outdrive movement.

- H. Inspect for fuel odors and visible leaks in the fuel, oil, coolant, exhaust and power steering systems.
- I. Make sure boat is securely moored to the dock and engine is idling. Then move the throttle forward and then aft and back to neutral to check for proper operation of the shifting motion. Be careful. Leave the engine in gear for only a split-second.

## 2. Starting Procedures for Diesel Engines with Volvo Penta Electronic Vessel Control (EVC)

- A. Activate the batteries by placing the switches on the Power Management Panel or 12VDC cabin panel to the ON position. Place the Helm Main circuit breakers to the ON position (if equipped). Check all electrical systems and navigation lights.

- B. Activate the Bilge Blower. Check the blower output.



*Fuel vapors can explode resulting in injury or death. Before starting the engine, check engine compartment bilge for fuel or vapors. Operate blower for four minutes, and verify blower operation. ALWAYS run the blower when the vessel is operating below cruising speed.*

- C. Open the seawater seacocks on the drive units (if applicable).
- D. Turn the ignition key to the ON position "I" and wait 20 seconds, allowing pre-heaters to activate.
- E. Check for audible warnings, information messages or alarms on EVC system displays.
- F. After 20 seconds, turn key switch to START position and hold until engine starts. DO NOT hold in START position for more than ten seconds. If one of the designated engine batteries fails to start its respective engine, engage the "EMERGENCY START" switch at the helm and attempt to start the engine.
- G. As soon as engine starts, release key to the ON or RUN position.
- H. Once engine has warmed up, check water temperature to ensure engine temperature stays within optimum range. If temperature reading is abnormally high, stop engine immediately and inspect for cause of high reading.

- I. Inspect for fuel odors and visible leaks in the fuel, oil, coolant and exhaust.

- J. Make sure boat is securely moored to the dock and engine is idling. Then move the throttle forward and then aft and back to neutral to check for proper operation of the shifting motion. Be careful. Leave the engine in gear for only a second.

## T - 5 MANEUVERING

When all your pre-departure checks have been completed and the engine has warmed up, you will be ready to leave the dock. Take into account the amount of wind, tide current, and other forces that may affect your maneuvering as you leave the dock. Idle speeds work best when maneuvering to and from the dock. Do not forget to release the mooring lines.

### A. Leaving the Dock

You are ready to leave the dock after the engine has warmed up. Check all EVC displays for appropriate readings before casting off. If oil pressure is abnormally low or engine temperature is abnormally high, stop the engine immediately. Check voltmeter to be sure the charging system is working properly. Check for fuel, oil, and exhaust leaks. Correct the cause of any abnormal condition before getting underway.



*To prevent personal injury, swim platform must not be occupied and transom door must be closed while engines are running.*

After making sure your boat is ready, check wind, tide, current and other forces that will affect the way you maneuver your boat away from the dock. Throw mooring lines off to your boat. Shift your boat's engine into forward or reverse depending on whether you want to move the bow or the stern away from the dock first. Run your engine at a slow speed as you move away from the dock. If you move the bow out first, watch that the stern of the boat does not swing into the dock or a piling.

Once away from the dock, devote some time to learning how to maneuver. Practice docking using an imaginary dock. Practice stopping and reversing.

## B. Stopping

Boats have no brakes. Stopping is accomplished by backing down on the throttle. Practice stopping maneuvers and learn early how your boat reacts. From forward motion, pull the throttle back towards NEUTRAL. Depending on your speed, the distance the boat travels until it comes to a complete stop will vary. The ability to measure the distance will only be acquired through experience.

Once the boat has slowed and motor is idling, place the shift in REVERSE. Gradually increasing reverse power with the throttle will allow you to stop the boat in a very short distance.

**NOTE:** A boat will not respond to steering in reverse nearly as well as it does when going forward, so do not expect to accomplish tight turning maneuvers when backing up.

Remember that all boats steer by the stern (the feeling is much like steering your automobile in reverse). This means that the stern of your boat will swing in the direction opposite to your turn. For example, when you turn the helm wheel to the left, the stern of your boat will swing in the direction opposite to your turn. This is especially important to keep in mind when docking, operating in close quarters with other boats, or when approaching a swimmer or downed skier in the water.

Always look behind you and to both sides of the boat before slowing down. Tell your passengers your intentions to allow them time to make adjustments to their balance or positions.

Slowly pull back on throttles, glance back and see if a large following wave is approaching the transom. If so give the engines a little throttle as the wave arrives to keep wave from rolling over the transom.

Once you have spent enough time practicing maneuvers and have a feel for how the boat handles, you will be ready to run in open waters.

## T - 6 ACCELERATION



*Before accelerating to bring your boat on plane, be sure that the area in front of your boat is clear. The bow will rise out of the water momentarily before you plane and may temporarily obstruct your vision.*

If you have never had your boat on plane before, choose a calm day for your first on plane experience. Never boat beyond your ability and experience.

Before bringing your boat “on plane”, check the entire area to make sure you have a clear, safe path. As you throttle up to accelerate, your boat will increase its angle of trim, causing the bow to ride high. From a maximum angle, the boat will level out to its planing attitude with continued acceleration. This maximum angle is known as the “hump”. Because visibility, handling, and performance are reduced, it is advisable to get “over the hump” as soon as possible. A few seconds at full throttle should get the boat over the hump and into its planing attitude.

After getting over the hump, accelerate until reaching a comfortable plane, then throttle down to cruising speed. This also will provide for better fuel efficiency.

## T - 7 TRIMMING YOUR BOAT

Trim tabs are used to add lift to the boat’s stern, thereby changing the boat’s attitude. This lift can help the boat get on plane faster and remain on plane at slower speeds than if no tabs were used. Used independently, tabs can also correct listing conditions caused by crosswinds, unbalanced loading and quartering seas.

Before accelerating and trying to gain plane, press upper button. This will cause both trim tab blades to lower in parallel and force the bow down when running. This can also be used when running the boat with a heavy load aboard.

Moving the trim tab blades downward will increase the lift and the boat will achieve plane faster, or stay on plane at a lower engine and boat speed. After gaining plane and establishing cruising speed, pressing the lower button retracts the blades in parallel and will allow the bow to rise. This should be used to adjust the running attitude of the boat to

decrease the drag at cruising speed or above, or when running in a following sea.

When running at an engine speed that results in the boat falling off plane or causes the boat to plane inefficiently, lowering the blades slightly (bow down) will improve the running angle and improve operating efficiency.

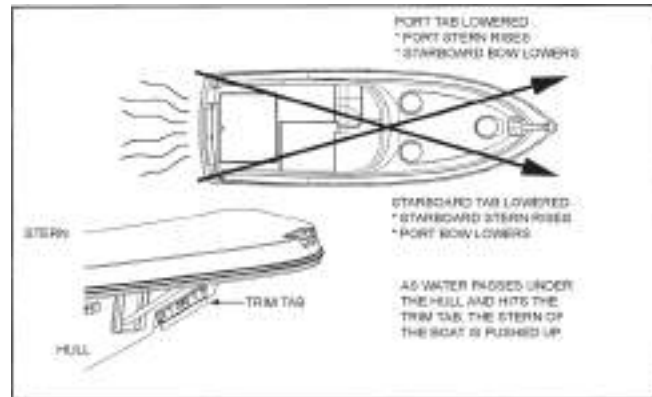
Optimum efficiency is obtained when operating at a 3 to 5 degree running angle. Utilizing too much "Bow Down" trim tab can reduce operating efficiency and cause substantial steering and handling difficulties. Be extremely careful when running in a following sea. The effect of trim tabs is amplified under such conditions. Steering and handling difficulties can result from improper trim tab usage, especially in a following sea. If unsure of proper trim tab positioning, raise the trim tabs to the full-up position.

Trim your boat to compensate for seas, winds, or uneven loads.

Head Seas	Trim drives in more than usual. Use tabs to keep bow down and go at a slower speed.
Following Seas	To prevent taking seawater  The bow, trim drives out and keep tabs up to keep bow down
Listing Due to Quartering Seas, Beam Wind, or Uneven Load	Use tabs independently to adjust for list. If listing to starboard, press port bow down switch. If listing to port, press starboard bow down switch.

Remember that most boats react very slowly to trim tabs. Often boat owners do not give trim tabs time to work. Press the trim tab switches for only one second at a time and then allow some time for the boat to react. If the boat is still listing after a minute or two, press the trim tab switch again for a one second interval. The labels on the trim tab switches indicate what you want your boat to do, not what you want the tabs to do.

It is a good idea to take your boat out onto open water shortly after you get it and experiment with the trim tabs. After you get your boat onto plane, set the tabs in various positions and note how your boat reacts. This will give you a feel for how the trim tabs work.



**Figure T1: Trimming the Boat with Trim Tabs**

## T - 8 NAVIGATION LIGHTS

Although night activities are limited, cruising at night can be very pleasurable. It can also be dangerous if you don't pay close attention to water levels and obstacles. Be especially careful of shallow waters and watch for submerged debris, rocks and other obstacles in the water. Your navigation lights are intended only to prevent collision, not to improve your night vision. You may choose to use a spotlight instead.

**NOTE:** It is illegal to use your spotlight as a headlight. Use it only temporarily to check the position of your boat and the surrounding area.

Depending on your model, the boat has one white (stern or mast light), one red (port) and one green (starboard) light. The stern light may be a removable pole light. To use the light, line up the two-prong plug in the pole with the receptacle in the base. Plug the light in, and lock it into place with lever/slide lock. When not in use, stow the light inside your boat for safekeeping. This light can be turned on or off at the helm.

Check lights for proper operation before heading out at night. You should also learn to identify the running light combinations for other vessels. We recommend that you participate in a boating safety course to further learn about navigation lights and safe boating practices.

The anchor lights and navigation lights are controlled by a switch at the helm. The anchor light switch allows you to turn on just the stern (white) light when anchored or moored. While underway, use the navigation light switch to turn on the stern or mast light (white), port (red) and starboard (green) lights. Lights are off when switches are in the OFF position.

## T - 9 HAZARDOUS CONDITIONS

### A. Storms

Storms sometimes appear without advance notice. Although weather information from meteorological observation and reporting stations is available, weather bureaus are known to have failures in their predictions or information gathering equipment. There is no substitute for a strong understanding of what action to take when the weather takes a turn for the worse. Many marinas fly weather signals. You should learn to recognize these signals and monitor your local weather forecasts before leaving port.

The present and forecasted weather conditions are of primary consideration, but a threat of possible storms should always be a concern. Observance of the following information will help in your safety afloat if storms do occur:

- Keep a watch on the horizon for approaching storm indicators.
- Turn radio ON. Dial in local weather station and monitor forecast. If your boat has a VHF radio, check the weather channels.
- The best possible situation is to return to a safe port if time allows.
- Close and secure all portals and hatches. Stow all loose gear below deck and tie down any gear required to remain on deck.
- Reduce speed as the seas build. Make sure all passengers are wearing their PFDs.
- If you lose power, keep the boat headed into the waves by rigging a sea anchor off the bow. If there is no sea anchor on board, use a canvas bucket or any object that will offer resistance.
- Radar reflectors (if installed on your boat) should be 18 inches diagonally and placed 12 feet above the waterline.

### B. Fog

Fog is a result of either warm surface or cold surface conditions. You can judge the likelihood of fog formation by periodically measuring the air temperature and dew point temperature. If the spread (difference) between these two temperatures is small, you likely will incur a fog situation. Remember the following guidelines:

- Turn on running lights.
- As fog sets in, take bearings and mark your position on the chart while continuing to log your course and speed.
- Make sure all persons aboard are wearing their PFDs.
- If your boat has depth finding equipment, take sounding and match them with soundings on your charts.
- Station a person forward on the boat as a lookout.
- Reduce your speed. From time to time, stop engine and listen for fog signals.
- Sound the proper horn or fog bell at proper intervals to warn other boaters.
- If there is any doubt in continuing boat movement, anchor. Listen for other fog signals while continuing to sound the proper fog horn or bell for a boat at anchor.

### C. Running Aground



*To prevent boat damage, DO NOT use deck hardware or water ski pylon for towing. Use a commercial towing service.*

Operating in shallow water can present a number of hazards. Sand bars in narrow inlets are constantly shifting, making it difficult to mark them with buoys. Sometimes sand bars are indicated by waves as they form into breakers when passing over sand bars. In coastal areas, tides can change water levels by as much as 30 feet. Check with local marinas or Coast Guard stations for tide tables and current charts.

If your boat runs aground, first check persons aboard for injury. Then check for damage to the boat. If the drive unit strikes an underwater hazard, check for boat and drive unit damage. If the engine vibrates excessively after striking an underwater obstruction, it may indicate a damaged propeller. If vibration is noticeable, return to port slowly to prevent further drive and engine damage from an out-of-balance condition. Watch the temperature gauge to make sure you do not overheat the engine.

If the boat is not taking on any water, it may be possible to rock the boat by shifting the weight of the passengers and gear and by raising the drive unit while reversing the engine.

If you ground your boat on a sand bar, shut down the engines and seek help from another boater or radio for help. See your dealer as soon as possible, as sand ingested in the engine cooling system can cause major engine damage.

#### **D. Warning Markers**

It is a good idea to find out about hazardous areas and how they are marked by asking your local authorities.

- Boaters must also recognize the flag designs which indicate that scuba divers are present and keep well clear of the area.
- Watch for swimmers. Swimming areas may not be marked. Steer clear from the area and always remain alert.
- Distress flags indicate a fellow boater is in need of assistance.
- Navigation markers serve as a means of identifying navigable routes and indicate water hazards. Boaters should become familiar with navigation markers and stay within marked boundaries and clear of hazards.

### **T - 10 REACTING TO EMERGENCIES**

Be prepared to deal with emergencies before they happen. Try to formulate a plan for each type of emergency in advance so that decisions can be made quickly and without hesitation. Precious moments lost can mean the difference between losing and saving a life.

#### **A. Flooding**

If your boat starts taking on water, activate the bilge pump immediately. Make sure all passengers are wearing their PFDs. Open the engine compartment, look for the cause of the flooding. Check all hoses, through hull fittings, seacocks and strainers. If flooding occurs as a result of collision or grounding damage, call for assistance and head for shore if possible.

#### **B. Capsizing and Man Overboard**

By far, the largest number of boating fatalities involve capsizing and falling overboard accidents. By being prepared ahead of time with an appropriate plan of action, you can greatly lower your chances and your passengers' chances of becoming seriously injured.

#### **C. Capsizing**

Wear PFDs or have them readily available at all times. If your boat capsizes, and others were on board, locate them and guide them to the safety of the hull. Even if the boat floats in an upside-down position, stay with it. The boat hull is much easier for rescuers to spot than a human head sticking out of the water. DO NOT attempt to swim ashore, it may be further than it looks.

#### **D. Man Overboard**

Think through and follow these procedures if someone in your boat falls overboard.

- Remember, every second counts, you must act fast.
- Move throttles to idle position immediately and yell "MAN OVERBOARD."
- Throw some floating object overboard immediately. Keep your required Type IV PFD accessible at all times for such an emergency.
- Keep the person in the water in sight at all times. Have a passenger do nothing but watch the person. Do not go into the water to help the victim. One person in the water is enough trouble.
- Circle around quickly, approaching into the wind and waves. When the person is alongside, put the engine in neutral and throw them a Type IV PFD with a line attached or extend a paddle or boat hook within his/her reach.

## E. Collision

If a serious collision occurs, you should first check the condition of all passengers aboard, then inspect your boat to determine the extent of damage.

1. Make sure all persons aboard are wearing their PFDs.
2. If you need help and your boat has a ship-to-shore radio, first contact the U. S. Coast Guard (VHF Channel 16) or other rescue authorities immediately.
3. Prepare to assist the other vessel unless your passengers and/or boat are in danger.
4. If the bow of the other boat penetrated your boat's hull, prepare to block the opening once the boats are separated.
5. Shore up the hole with a spare PFD or bunk cushion from your boat.
6. While blocking the hole, trim the boat so that the hole is out of the water.

## F. Fire

Most fires are caused by electrical problems or careless fueling practices. A fire on board your boat is a serious emergency. You must work quickly to implement safety procedures. If a fire occurs, immediately stop the engine.

1. Make sure all persons aboard are wearing their PFDs.
2. If the fire is small, attempt to put it out with your fire extinguisher. If the fire is in the engine compartment, turn off the bilge blower. Do not open the engine compartment. This feeds oxygen to the fire and may cause it to flare up.
3. If the fire gets out of control, execute a distress signal and call for help if equipped with a ship-to-shore radio.
4. All persons aboard should jump overboard and swim a safe distance away from the flames.

**IMPORTANT:** All persons aboard should know the location and proper operation of the fire extinguishers.

## Guidelines

- Use only approved marine cooking and heating systems.
- Open flames demand constant attention.
- Keep flammable materials in approved containers in an overboard vented locker sealed from the interior of the boat.
- Ensure ventilation systems are unobstructed.
- Remove mooring covers before starting engine.
- Check the bilge for fuel leaks.
- Extinguish smoking materials carefully.
- Use special care with flame or high temperatures around urethane foam.
- Check cleaning products for flammability.
- Ventilate when cleaning or painting.
- Disconnect electrical system from its power source before performing maintenance.
- Replace breaker or fuse with same amperage device.
- Electrical appliances must be within rated amperage of boat circuits. Observe the boat carefully while the electrical system is being energized.
- Allow only a qualified marine electrician to service the boat's electrical system.

## G. Medical Emergency

Accidents while boating can and may happen. Be prepared to handle these emergencies when they happen. Keeping a first aid kit and dry blankets on board can assist during these situations. It is also a good idea to contact your local Red Cross for information and training on first aid and CPR.

## H. Propulsion Failure

**Note:** Refer to your engine manual for specific information regarding propulsion failure for your specific V series model.

Before you call for help regarding an engine or drive unit failure, it is a good idea to eliminate the possibility of simple problems. Turn off the engine and check to see that (1) there is fuel in the tank; (2) the engine cooling intakes on the drive are not clogged; (3) props are clean and free of weeds, netting, etc. ; (4) no hoses are leaking; (5) there is oil in the engine.

Once you have checked out the possibilities listed above and find they are not the problem, call for help giving your position and a detailed description of your boat.

### I. Control Failure

**Note:** Refer to your engine manual for specific information regarding control failure for your specific V series model.

In the unlikely event of a shift/throttle failure, shut down the engine immediately. Carefully check the control connections in the engine compartment to see if they are secure. If not, try to locate the attaching hardware and reassemble. If that is not possible, try to use whatever is available such as paper clips, hair clips, tape, etc., to secure the connections. If a temporary repair is made, return to port at the slowest steerable speed and be prepared to take emergency action should the temporary repair fail also. Have your dealer make repairs before using the boat again.

**Note:** For V series utilizing Volvo Penta IPS propulsion, the emergency shifting procedure is taken directly from the engine manual and has been included below.

In the unlikely event of a shift/throttle failure, observe the fault displays on the EVS displays. Acknowledge the alarm and take the recommended measures referred to in "Fault Register" chapter of the engine manual. It may be advisable to shut down the engines on both sides and try to restart them again. If error remains after restart have the boat towed to an authorized service facility. Should emergency shifting become necessary see the following emergency shifting procedure.

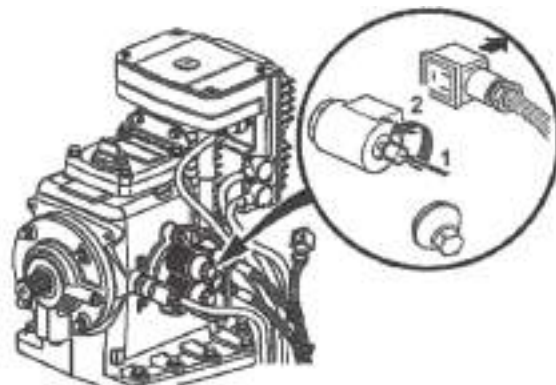
Emergency shifting procedure:



*In emergency shifting, the unit is locked in forwards operation. Please note that the gear can not then be disengaged with the control lever. Forward motion can only be cut off by stopping the engine with the ignition key or stop button.*

**Note:** This description is for manual engagement of the drive-unit, for forward travel. Refer to Figure T2.

1. Stop the engine and remove the start key from the key switch.
2. Note the valve to which the cable marked "Primary" (lower solenoid) is connected. Then undo both connectors from the solenoid valves.  
**NOTE! P is forward and S is backward.**
3. Remove the cap nut from the valve which was connected to the "Primary" cable.
4. Press the valve (1) while turning (2) the button a 1/2 turn **counter-clockwise** (the button is forced out by spring action). The drive-unit is now connected for forward motion and cannot be disengaged by the control lever.



**Figure T2: Emergency Shift Procedure**

### J. Steering Failure

**Note:** Refer to your engine manual for specific information regarding steering failure for your specific model.

If a problem with the steering occurs, observe the fault displays on the EVS displays. Acknowledge the alarm



and take the recommended measures referred to in the “Fault Register” chapter of the engine manual. Shut down the engines immediately and restart. If error remains after restart have the boat towed to an authorized service facility.

If the steering is not operating properly, do not operate the boat and call for assistance. In the extreme circumstance that the boat had to be steered, it could be done using control levers. See the engine manual for details. Also, refer to the section called “Alignment of the Drive-unit” in the engine manual under the “In Case of Emergency” chapter in order to place the drive-unit straight forward without using the steering wheel.

### K. Additional Underway Information

- Always be aware of local laws on noise limits. Noise means engine noise, radio noise or even yelling by people on your boat. Good seamanship demands that you operate your boat quietly so as not to infringe on the rights of others. Don't use thru-transom exhaust unless you are well off shore.
- You are responsible for any damage or injury caused by your boat's wake. Observe no wake speed zone warnings. Operate your boat with regard for the safety of other boats and people in your boating area.
- Keep your engine well tuned to decrease exhaust hydrocarbon emissions that pollute the air and water.

## T - 11 RETURNING TO SHORE

### A. Docking

Always approach the dock slowly. Think before acting. If you are wondering whether your boat will fit in a space against a dock, remember that pilings are often (but not always) spaced 10 feet apart.

Remember that it is easier to control a boat in reverse because a boat steers from the stern. When backing into a slip, back so that bow swings into the wind if possible. You will have more control.

If possible, come in against the wind or current, whichever is stronger. Approach the dock at a 30-45° angle. As the boat nears the dock, slowly swing

parallel to it. Tie the bow line first; then the stern. If wind or current is moving toward the dock, move parallel to the dock further out. Let the wind or current push you in. Tie the stern first, then the bow.

Use extreme caution if wind or current is from your stern. Back in towards the dock slowly at a slight angle with engine in slow reverse. Gently swing parallel. Tie stern first, then the bow.

If the weather looks bad, use spring-lines from the bow and stern to dock amidships of the boat. Tie up on the downwind side of the dock. If the wind is changeable, place fenders over the side between the boat and the dock.

### B. Mooring

After you have positioned your boat next to the dock, you must secure it with mooring lines to keep it in position. Mooring lines must be long enough to secure your boat in any docking situation.

For example, dock lines should be at least 2/3 of the length of your boat and the spring lines should be at least the full length of your boat. The size (diameter) of your line depends on the size and weight of your boat. The following is an approximate guide. See your Four Winns dealer for recommendations.

	Line Diameter
Boats under 20 feet =	3/8"
Boats 20 to 30 feet =	1/2"
Boats 30 to 40 feet =	5/8"
Boats 40 to 60 feet =	3/4"
Boats over 60 feet =	1"

**Note:** If your boat is heavy for its size, consider going up one size in diameter.

An eye splice at the end of each line works well with bow or stern cleats.

The mooring lines you will use most often are the bow line, the stern line, and spring lines as shown on Figure T3. Each line has a specific purpose. The bow line and the stern line secure your boat's bow and stern. The two spring lines keep your boat from moving forward or backward when you are moored alongside a dock.

If you are mooring your boat for a short time, bow and stern lines may be the only lines you will need. If you are mooring your boat for a longer time or the currents

are swift, you should use spring lines. The stern spring line leads from the boat's stern cleat forward to the piling or cleat on the dock. The bow spring line leads from the bow cleat aft to the dock.

If you are mooring your boat in a slip, bow and spring lines, port and starboard, will keep your boat in position.

**Note:** If tides are a consideration, be sure to leave slack in the lines to make up for the rise and fall of the water while your boat is docked.

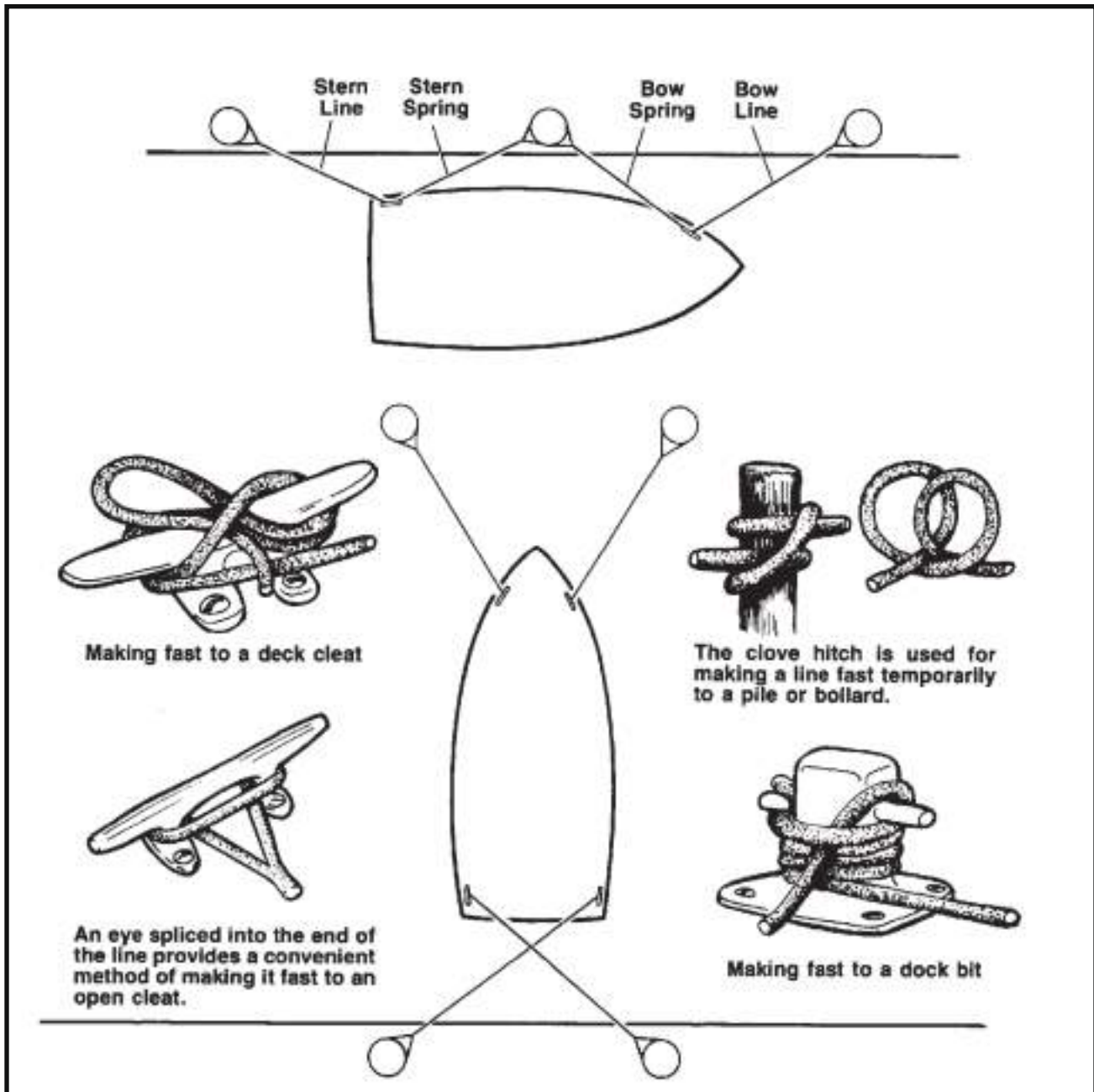


Figure T3: Mooring Lines

**ABAFT** - Toward the rear of a boat.

**ABEAM** - At right angles to the keel of the boat.

**ABOARD** - On the boat.

**ABREAST** - Side by side.

**ADRIFT** - Loose, not on moorings or towline.

**AFT** - Moving toward the stern, you are going aft.

**AGROUND** - Stuck fast to the bottom.

**AHEAD** - In a forward direction.

**ALEE** - Away from the direction of the wind; opposite of windward.

**ALOFT** - Above the deck.

**AMIDSHIPS** - 1. An object or area midway between the bow and stern. 2. An object or area midway between the port side and the starboard side of a vessel.

**AMPERE** - The standard unit used to measure the draw of an electrical current.

**ANCHOR RODE OR ROPE** - The line (chain) connecting a vessel to its anchor.

**ANCHOR BALL** - A black, circular, day signal hoisted to show that a vessel is anchored. Replaced at dusk by the anchor light.

**ASTERN** - Anywhere behind the boat, a reverse direction, opposite of ahead.

**ATHWARTSHIPS** - A line, or anything else, running perpendicular to the fore-and-aft center line of a boat.

**BATTEN** - A strip of wood or metal used to secure tarpaulin(s) in place over a hatch. To batten down means to secure for rough weather.

**BEAM** - 1. The widest distance across a boat from the outside skin on one side to the outside skin on the other. 2. A transverse structural member that stiffens and supports a portion of the deck.

**BEAM WIND** - A wind blowing against the side of the vessel, perpendicular to the long axis of the vessel.

**BILGE** - The lowest interior area of a hull, used to collect water that has entered.

**BILGE PUMP** - A pump intended for removal of spray, rainwater, and the normal accumulation of water due to seepage and spillage; not intended for damage control.

**BINNACLE** - The stand or support for a magnetic compass occasionally used to mean helm.

**BITT** - A heavy and firmly mounted piece of wood or metal used for securing lines.

**BLOCK** - A wooden or metal case enclosing one or more pulleys and having a hook, eye, or strap by which it may be attached.

**BOLLARD** - A single post (wood, metal, or concrete) on a dock, pier, or wharf used to secure a vessel's lines.

**BONDING** - The electrical connection of exposed metallic, non-current carrying components to a common point on the main engine block.

**BOW** - The front end of the boat.

**BOW LINE** - A docking line leading from the bow.

**BREAKER** - A single breaking, plunging or spilling wave.

**BREAKER LINE** - The outer limit of the surf. However, all breakers may not be in a line. They can occur outside the breaker line.

**BRIDGE** - The main vessel control station.

**BROACH** - The turning of a boat parallel to the waves, subjecting it to possible capsizing.

**BULKHEADS** - The interior walls of a boat.

**BULWARK** - The side of a vessel when carried above the level of the deck.

**BUOY** - An anchored float used for marking a position on the water, a hazard, or a shoal.

**CAPSIZE** - To turn over.

**CAPSTAN** - A machine that moves a cylindrical device on a shaft for the purpose of hauling up an anchor.

**CAST OFF** - To let go.

**CATAMARAN** - A twin-hulled boat, with the hulls being side-by-side.

**CHINE** - The intersection of a boat's bottom and side. If this intersection is rounded, it is a "soft" chine. If the intersection is squared off, it is a "hard" chine.

**CHOCK** - 1. A fitting or hole in a railing or deck through which a mooring or anchor line is routed.  
2. A wedge used to secure an item in place.

**CIRCUIT BREAKER** - A device used to interrupt an electrical circuit when current flow exceeds a predetermined level.

**CLEAT** - A double-ended deck fitting to which lines are secured; usually anvil-shaped.

**COAMINGS** - Raised lips around cockpits or hatches used to keep water from entering

**COCKPIT** - An exposed deck area (usually aft) that is substantially lower than the adjacent deck.

**COMBER** - A wave on the point of breaking. A comber has a thin line of white water on its crest, known as "feathering."

**COMPANIONWAY** - The steps or ladder leading downward from a deck.

**COMPARTMENTS** - Rooms divided by bulkheads.

**COUNTER** - The overhang at the stern of a boat.

**CRADLE** - A framework, generally made of wood, used to support a boat when it is out of the water.

**CREST** - The top of a wave, breaker or swell.

**CUDDY** - A small sheltered cabin in a boat.

**CURRENT** - 1. The movement of water,  
2. The flow of electrical charge.

**DEAD AHEAD** - Directly in front of the boat.

**DEAD RECKONING** - A plot of courses steered and distances traveled through the water.

**DECK** - A permanent covering over a compartment, hull or any part thereof.

**DESIGNATOR** - Model identifier or model name.

1. to mark or point out; indicate; show; specify.
2. to denote; indicate; signify.
3. to name; entitle; style.

**DINGHY** - A small, open boat used for ship to shore transportation.

**DISPLACEMENT** - The weight of water displaced by the hull of a vessel.

**DISPLACEMENT HULL** - A hull that "displaces" a volume of water equal to the weight of the boat. A hull designed to run in the water rather than on top of the water. When a displacement hull moves through the water, it pushes that water out of the way. Water will then flow around the hull and fill the "hole" the boat leaves astern.

**DOCUMENTED VESSEL** - Documented yachts have been specially registered with the U.S. Coast Guard. All documented yachts must have their name and home (hailing) port marked on some conspicuous place on the hull. Numbering is not required. Advantages include legal authority to fly the yacht ensign, privilege of recording bills of sale, and other instruments of title with federal officials, and preferred status for mortgages. Documentation does not exempt the unit from any State or Federal taxes. All safety and equipment regulations still apply.

**DOLPHIN** - A group of piles driven close together and bound with wire cables into a single structure.

**DRAFT** - 1. The depth of a boat from the actual water line to the bottom of the lowest part of the boat (e.g., the propeller tip or rudder). 2. The depth of water necessary to float a boat.

**DROGUE** - Any device streamed astern to check a vessel's speed, or to keep its stern up to the waves in a following sea.

**DYE MARKER** - A brightly colored chemical that spreads when released into water; normally used to attract attention.

**EBB TIDE** - A receding tide.

**EVEN KEEL** - To be floating evenly without listing to either side.

**EXHAUST SYSTEM** - The means by which the hot engine (or generator) exhaust gases are moved from the engine to an outboard port and then released into atmosphere.

**EYE SPLICE** - A permanent loop spliced in the end of a line.

**FAST** - Said of an object that is secured to another.

**FATHOM** - Six feet.

**FENDER** - A device (usually constructed of rubber or plastic) positioned so as to absorb the impact between vessels or dock.

**FETCH** - The unobstructed distance that the wind can blow over the water to create waves.

**FLARE** - 1. Outboard curve of the hull as it comes up the side from the waterline; the reverse of tumble home. 2. A pyrotechnic device used for emergency signaling.

**FLAT** - A small deck that is built below decks, specifically to support a piece of equipment.

**FLEMISH** - To coil down a line or rope on deck in a flat, circular, concentric arrangement.

**FLOTSAM** - Floating wreckage, trash or debris.

**FLUKE** - The palm of an anchor.

**FOAM CREST** - The top of the foaming water that speeds toward the beach after a wave has broken, commonly referred to as "white water."

**FOLLOWING SEA** - A sea (waves) moving in the same direction as a vessel.

**FORE-AND-AFT** - A line, or anything else, that runs parallel to the longitudinal center line of a boat.

**FOREFOOT** - The portion of a vessel's keel that curves upward to meet the stem.

**FOREPEAK** - A compartment in the bow of a boat.

**FORWARD** - Toward the bow.

**FREEBOARD** - The minimum vertical distance from the surface of the water to the gunwale.

**FREQUENCY** - The number of crests passing a fixed point at a given time.

**FRONTS** - Where opposing warm and cold air masses meet, generally producing a band of wet, stormy weather wherever they meet.

**GALLEY** - The kitchen area of a boat.

**GALVANIC CORROSION** - A potential electrical difference exists between dissimilar metals immersed in a conductive solution (e.g., salt water). If these metals touch or are otherwise electrically connected, this potential difference produces an electron flow between them. The attack on the less corrosion resistant metal is usually increased and the attack on the more resistant metal is decreased, as compared to when these metals are not touching.

**GANGWAY** - The area of a ship's side where people board and disembark.

**GASKET** - A strip of sealing material, usually rubber, set along the edge of a water or gas tight door, port, cover or hatch.

**GELCOAT** - The thin outer layer of pigmented plastic covering a fiberglass vessel.

**GLAND** - The movable part of a stuffing box, which when tightened, compresses the packing.

**GROUND** - Electrical term meaning the electrical potential of the earth's surface, which is zero.

**GROUND SPEED** - A vessel's speed made good over the earth's surface along a course or track.

**GROUND TACKLE** - The anchor, anchor rodes, and other fittings that are used to secure a vessel at anchor or dockside.

**GUNWALE** - 1. The line where the upper deck and the hull meet. 2. The upper edge of a boat's side.

**HALYARD** - A line used to hoist a flag or pennant.

**HATCHES** - Cover on hatchways.

**HATCHWAYS** - Access ways through decks.

**HARDTOP** - A permanent cover over the cabin or cockpit.

**HAWSER** - A heavy rope or cable used for mooring or towing.

**HEAD** - A toilet or lavatory area.

**HEADING** - The direction that a vessel is going with reference to true, magnetic, or compass north.

**HEADWAY** - The forward motion of a vessel through the water.

**HEAVE TO** - To bring a vessel up in a position where it will maintain little or no headway, usually with the bow into the wind.

**HEAVY WEATHER** - Stormy weather with high seas and strong winds.

**HEEL** - To tip to one side.

**HELM** - The wheel or tiller that manually controls the boat's steering system.

**HELMSMAN** - The individual steering the vessel.

**HIGHS** - A center of pressure surrounded by lower pressure on all sides. Caused by a mass of cooler, sinking, drier air. This raises the area ground level air pressure and provides clear skies.

**HULL** - The main body of a boat.

**INBOARD** - 1. From either the port or starboard side of a boat toward the fore-and-aft centerline of a boat. 2. The dock side of a moored boat.

**INLAND RULES** - Nautical "Rules-of-the-Road" that apply in U.S. lakes, rivers, and coastal waters.

**INTERNATIONAL RULES** - Nautical "Rules-of-the-Road" that are in effect by international agreement to the high seas.

**ISOBARS** - Lines of equal air pressure that connect all the local points on a weather map. These lines are usually closed and define high or low pressure air masses.

**ISOTHERMS** - Isotherms are lines that are similar to Isobars except that Isotherms connect all the points that are of equal temperature.

**JETSAM** - Refuse that sinks when discharged overboard.

**KEDGE(S)** - One or more anchors set out from a grounded vessel, usually astern, to 1) keep it from being driven further aground and 2) to aid in refloating.

**KEEL** - 1. The centerline of a boat hull bottom running fore and aft, 2. The backbone of a vessel.

**KNOT** - 1. A maritime unit of speed equal to one nautical mile per hour (6076 feet). 2. A term for hitches and bends.

**LANYARD** - A short line made fast to an object to secure it.

**LATITUDE** - The measure of angular distance in degrees, minutes, and seconds, north or south of the equator.

**LAZARETTE** - Storage compartment in the deck at the stern.

**LEADLINE** - A weighted line used to take depth measurements.

**LEE** - The direction opposite that of the wind.

**LEEWARD** - Away from the wind.

**LIST** - A vessel that inclines to port or starboard.

**LORAN** - Long Range Navigation. An electronic system whereby a navigator can determine position regardless of weather.

**LONGITUDINAL** - Running lengthwise.

**LOWS** - A region of low atmospheric pressure. Hurricanes are extremely concentrated low pressure systems.

**LUBBER LINE** - A mark or line on the compass parallel to the keel indicating forward.

**MAST** - A spar that is set upright to support lighting, rigging, or sails.

**MODEL DESIGNATOR** - Model identifier or model name.

**MOORING** - An arrangement for securing a boat to a mooring buoy or pier.

**NAVIGATION LIGHTS** - A set of red and green or white lights which must be shown by all vessels between dusk and dawn.

**OVERHEAD** - A ceiling or roof of a vessel.

**OVERBOARD** - Over the side of the boat.

**OUTBOARD** - 1. From the fore-and-aft centerline of a boat toward both the port and starboard sides. 2. The seaward side of a moored boat. 3. An engine that is mounted externally onto the transom of a boat.

**PAINTER** - A line to the bow of a small boat used for making fast.

**PASSAGEWAY** - A corridor or hallway aboard ship.

**PENNANT** - The line by which a boat is made fast to a mooring buoy; also pendant.

**PERSONAL FLOATATION DEVICE (PFD)** - A life preserver.

**PIER** - A loading platform that extends at an angle from the shore.

**PILASTER** - A rectangular structural support column that is an extension of the port and starboard aft cabin sides and which supports the hardtop and flybridge.

**PILING** - Support, or protection for wharves, piers, etc.

**PITCH** - 1. The vertical (up and down) motion of a bow in a seaway, about the athwartships axis. 2. The axial advance of a propeller during one complete revolution.

**PITCHPOLING** - A boat being thrown end-over-end.

**PLACARD** - A board or stiff card bearing a notice, advertisement, message, etc.

**PLANING HULL** - At slow speeds, a planing hull will displace water in the same manner as a displacement hull. As speed is increased, the hull provides a lifting effect up onto the surface of the water.

**POINT** - One of 32 points of the compass that is equal to 11-1/4 degrees.

**PORT** - 1. Looking forward, the left side of a boat, 2. A harbor, 3. An opening for light or ventilation or passage of material in the side of a boat.

**PORT BEAM** - The left-center of a boat.

**PORT BOW** - Facing the bow, the front left side.

**PORT QUARTER** - Looking forward, a vessel's left rear section.

**QUARTER** - The sides of a boat aft of amidships.

**QUARTERING SEA** - Sea coming on a boat's quarter.

**RED-RIGHT-RETURNING** - A term for helmsmen that buoys and day markers are on the right when returning from seaward.

**REEF** - A shallow underwater barrier.

**REEVE** - To pass a line through a block or other opening.

**RIDGES** - High pressure fingers extending out from a high.

**RODE** - The anchor line or chain.

**RUNNING LIGHTS** - Lights required to be shown on boats underway between sundown and sunup.

**RUDDER** - A vertical plate for steering a boat.

**SALON** - The main social cabin on a vessel, usually the largest area, occasionally referred to as the deckhouse.

**SCREW** - A propeller.

**SCUPPER** - A drain from the edge of a deck that discharges overboard.

**SEACOCK** - A positive action shut-off valve connected directly to the hull seawater intake and discharge piping.

**SERIES** - A group of waves which seem to travel together and at about the same speed.

**SHACKLE** - A “U” shaped connector with a pin or bolt across the open end.

**SHAFT** - The long, round member that connects the engine or transmission to the propeller.

**SHAFT LOG** - A fitting at the hull bottom where the shaft connecting an engine to its propeller penetrates the hull. A shaft log permits the shaft to rotate while simultaneously preventing water from entering the hull.

**SHEER** - The top of the hull’s curvature at the deck line from the bow to the stern.

**SHEER STRAKE** - The upper edge of the hull, immediately below the deck.

**SHEET BEND** - A knot used to join tow ropes.

**SHOAL** - An area of shallow water.

**SILENCER** - A baffled chamber installed in an exhaust system to reduce the noise.

**SOLE** - Term for deck, cabin or cockpit floor.

**SPAR** - A general term for booms, masts, yards etc.

**SPRING LINE** - A pivot line used in docking, undocking, or to prevent the boat from moving forward or astern while made fast to a dock.

**STARBOARD** - Looking forward, the right side of a boat.

**STARBOARD BEAM** - The right-center of a boat.

**STARBOARD BOW** - When facing the bow, the front right side.

**STARBOARD QUARTER** - When looking forward, the right rear section of the boat.

**STEERAGEWAY** - The lowest speed at which a vessel can be controlled by the steering wheel.

**STEM** - The leading edge of a boat’s hull.

**STERN** - The back of a boat.

**STRINGER** - A fore and aft continuous member used to provide a vessel longitudinal strength.

**STRUT** - A propeller shaft support that is below the hull.

**SUMP** - A pit or well into which water is drained.

**SUPERSTRUCTURE** - Deck houses and other structures extending above the deck.

**THWART** - A seat or brace running laterally across a boat.

**THWARTSHIPS** - At right angles to the centerline.

**TILLER** - A bar or handle for turning a boat’s rudder, or motor.

**TOPSIDE** - To go up to the top deck.

**TRANSOM** - The stern cross-section of a square sterned boat

**TRANSVERSE** - Across the vessel; athwartships.

**TRIM** - Fore and aft balance of a boat.

**TROUGH** - 1. The valley that exists between waves. 2. A trough is the opposite of a ridge in that it is an elongated low-pressure area extending out from a low. A trough normally indicates unsettled weather.

**TUMBLE HOME** - The opposite of flare. The shape of the hull as it moves outboard going down from the gunwale to the waterline or chine.

**UNDERWAY** - Movement. Usually referring to a vessel proceeding forward.

**V-BOTTOM** - A hull with the bottom section in the shape of a “V.”

**V DRIVE** - A drive system that has the output of the engine facing forward and coupled to a transmission. The prop shaft is then coupled to the transmission.

**WAKE** - Moving waves, track or path that a boat leaves behind it when moving across the water.



**WATER LINE** - The line of the water on the hull when the vessel is afloat.

**WATCH** - A 4 hour duty period while at sea.

**WAVES** - Waves are periodic disturbances of the sea's surface, caused by wind, seaquakes, and the gravitational pull of the moon and the sun.

**WAVE GRADIENT** - A wave's slope or angle from trough to crest with respect to the horizon.

**WAVE HEIGHT** - From the bottom of a wave's trough to the top of the crest.

**WEATHER DECK** - A deck with no overhead protection.

**WET EXHAUST** - This term refers to an exhaust system where the cooling seawater is mixed with the exhaust gases just after the riser. This mixture is then ejected through the drive or ports located in the transom or hull sides.

**WHARF** - A man-made structure bounding the edge of a dock and built along the shoreline.

**WHIPPING** - The act of wrapping the end of a piece of rope with small line, tape or plastic to prevent it from fraying.

**WINDLASS** - A device used to raise and lower the anchor.

**WINDWARD** - Toward the direction from which the wind is coming.

**YAW** - 1. To swing off course, as when due to the impact of a following or quartering sea. 2. Any motion about a vertical axis.



Copy this page and fill out before going boating. Leave the completed copy with a reliable person who can be depended upon to notify the Coast Guard, or other rescue organization, should you not return as scheduled. **DO NOT** file this plan with the Coast Guard.

Name \_\_\_\_\_ Telephone \_\_\_\_\_

Description of Boat \_\_\_\_\_ Type \_\_\_\_\_ Color \_\_\_\_\_ Trim \_\_\_\_\_

Registration Number \_\_\_\_\_

Length \_\_\_\_\_ Name \_\_\_\_\_ Make \_\_\_\_\_

Four Winns® Hull Identification Number \_\_\_\_\_

Other Information \_\_\_\_\_

Persons Aboard: Name	Age	Address	Telephone

Engine Type \_\_\_\_\_ HP \_\_\_\_\_

Number of Engines \_\_\_\_\_ Fuel Capacity \_\_\_\_\_

**Survival Equipment:**

PFDs \_\_\_\_\_ Flares \_\_\_\_\_ Mirror \_\_\_\_\_

Smoke Signals \_\_\_\_\_ Flashlight \_\_\_\_\_ Food \_\_\_\_\_

Paddles \_\_\_\_\_ Water \_\_\_\_\_ Anchor \_\_\_\_\_

Raft or Dinghy \_\_\_\_\_ EPIRB \_\_\_\_\_ Sea Anchor \_\_\_\_\_

**Navigation Equipment:**

Compass \_\_\_\_\_ Loran \_\_\_\_\_ GPS \_\_\_\_\_ Radar \_\_\_\_\_

Radio: Yes \_\_\_\_\_ No \_\_\_\_\_ Type \_\_\_\_\_ Frequency \_\_\_\_\_

Phone: Yes \_\_\_\_\_ No \_\_\_\_\_ Phone Number \_\_\_\_\_

Destination \_\_\_\_\_ Estimated Time of Arrival \_\_\_\_\_

Expected to Return By \_\_\_\_\_

Auto Type \_\_\_\_\_ License No. \_\_\_\_\_ Where \_\_\_\_\_

If not returned by \_\_\_\_\_ call the Coast Guard, or \_\_\_\_\_  
Local Marine Authority

Coast Guard Telephone Number: \_\_\_\_\_

Local Marine Authority Telephone Number: \_\_\_\_\_

<b>DATE</b>	<b>HOURS RUN</b>	<b>FUEL (GAL.)</b>	<b>RANGE (MILES)</b>	<b>RPM</b>	<b>MPH</b>	<b>GPH</b>

<b>DATE</b>	<b>HOURS RUN</b>	<b>FUEL (GAL.)</b>	<b>RANGE (MILES)</b>	<b>RPM</b>	<b>MPH</b>	<b>GPH</b>

<b>DATE</b>	<b>HOURS RUN</b>	<b>FUEL (GAL.)</b>	<b>RANGE (MILES)</b>	<b>RPM</b>	<b>MPH</b>	<b>GPH</b>

DATE	HOURS	MAINTENANCE PERFORMED







BOAT MODEL	
HULL IDENTIFICATION NUMBER	
ENGINE MODEL	
ENGINE SERIAL NUMBER(S)	
DRIVE MODEL	
DRIVE SERIAL NUMBER(S)	
PROPELLER DIAMETER	
PROPELLER PITCH	
PROPELLER PART NUMBER(S)	
OIL FILTER NUMBER	
BOAT COLOR	
COCKPIT UPHOLSTERY COLOR	
CABIN UPHOLSTERY COLOR	
FUEL CAPACITY	
FUEL: ESTIMATED AVG. GALLON/HR USAGE	
IGNITION KEY NUMBER(S)	
COMPANIONWAY KEY NUMBER	
SELLING DEALER	
ADDRESS	
CITY & STATE	
PHONE NUMBER	
MISCELLANEOUS	

DEPARTMENT OF HOMELAND SECURITY  
U.S. Coast Guard  
**RECREATIONAL BOATING ACCIDENT REPORT**

OMB Control Number: 1625-0003  
Expires: 12/31/2015

**INSTRUCTIONS:** Use "Report required because" section below to determine if a report is required for your accident. If required, please have each vessel owner or operator involved in the accident submit a report to their state reporting authority. Each boat operator/owner involved in an accident should submit a separate report. For each question below, please provide answers if applicable and if known; otherwise leave blank. Privacy Act Notice: Authority- 46 U.S.C. 6102 and 33 CFR 173 & 174 authorize the collection of information on boating accidents. Purpose-The Coast Guard uses this information for statistical purposes, chiefly to inform the public, to measure the Program's efforts, and to regulate issues relating to boating safety. Routine Uses-The Coast Guard shares this information within the agency, and if state and federal law permit it, to the public.

**REPORT SUBMISSION**

**Report required because (select all that apply):**

- At least one person in this accident *died*. If so, how many? \_\_\_\_\_
- At least one injured person in this accident *required or was in need of treatment beyond first aid*. If so, how many? \_\_\_\_\_
- At least one person in this accident *disappeared* and has not yet been recovered. If so, how many? \_\_\_\_\_
- All boat and other property *damage (e.g., fishing/hunting gear) caused by this accident totaled (or likely totaled) \$2,000 or more*:  
 Approximate value of damage to *your* boat: \$ \_\_\_\_\_  
 Approximate value of damage to *your* other property: \$ \_\_\_\_\_
- Your or another *boat* in this accident was *(or likely was) a total loss*

**Report submitted by (select all that apply):**

- Boat Operator *(required if possible)*
- Boat Owner *(if operator unable, or same as operator)*
- Other *(describe):* \_\_\_\_\_

**To be submitted within:**

48 hours *(if injury, disappearance or death)*  
10 days *(if boat/property damage only)*

To be submitted to: *(Local State Reporting Authority)*

**Phone:**

You may submit any comments concerning the accuracy of the burden estimate or any suggestions for reducing the burden to: Commandant (CG-BSX-21), U.S. Coast Guard, Washington, DC 20593-0001 or Office of Management and Budget, Paperwork Reduction Project (1625-0003), Washington, DC 20503. Questions relating to the collection of this data should be sent to the Coast Guard.

**For State Agency Use Only**

First Name \_\_\_\_\_ Last Name \_\_\_\_\_

**Phone:**

First Name	Last Name	Phone
------------	-----------	-------

*Primary Cause of Accident*

**ACCIDENT SUMMARY**

<p><b>WHEN</b></p> <p>Date: _____ Time: _____ am <input type="checkbox"/> pm <input type="checkbox"/> <i>(mm/dd/yyyy) (select one)</i></p> <p><b>WHERE</b></p> <p>Body of Water Name _____</p> <p>Location <i>(on water)</i> description _____</p> <p>Nearest city/town _____</p> <p>County: _____ State: _____</p> <p><b>YOUR BOAT – PEOPLE</b></p> <p># people on board <i>(including operator)</i>: _____</p> <p># people being towed <i>(e.g., on tubes, skis)</i>: _____</p> <p># people wearing lifejackets <i>(on board or towed)</i>: _____</p> <p><b>OTHER BOATS INVOLVED IN ACCIDENT</b></p> <p># of other boats involved: _____</p>	<p><b>ACCIDENT DESCRIPTION:</b> <i>Briefly describe this accident (attach extra pages if necessary)</i></p> <p>_____</p> <p>_____</p> <p>_____</p> <p><b>DAMAGE TO YOUR BOAT:</b> <i>Briefly summarize any damage to your boat</i></p> <p>_____</p> <p>_____</p> <p>_____</p> <p><b>DAMAGE TO YOUR OTHER PROPERTY: (NOT BOAT)</b> <i>Briefly summarize any damage to your other property (not boat)</i></p> <p>_____</p> <p>_____</p> <p>_____</p>
--	--

For each question below, please provide answers IF APPLICABLE AND IF KNOWN, otherwise leave blank.

### YOUR BOAT

BOAT IDENTIFICATION															
Your Boat Name:						Manufacturer:									
Model Name:						Model Year:									
Registration #:						Documentation #:									
Hull Identification # (HIN)						Rented: <input type="checkbox"/> Yes <input type="checkbox"/> No									
SIZE ESTIMATES															
Length: ft.		Depth from transom (stern) to keel (bottommost point):				ft.		in.		Beam width at widest point: ft.					
HULL MATERIAL															
Type of Hull Material (select one)															
Fiberglass			Wood			Rubber/vinyl/canvas			Other (describe):						
Aluminum			Steel			Plastic									
BOAT TYPE															
Boat Type (select one)						Available Propulsion (select all that apply)									
Cabin motorboat		Inflatable		Canoe		Personal watercraft (PWC) (e.g., Wave Runner™, Jet Ski™, Sea-Doo™) Other (describe)			Propeller		Air thrust				
Open motorboat		Houseboat		Rowboat					Sail		Other (describe):				
Auxiliary sail		Sail (only)		Air boat					Manual						
Pontoon boat		Kayak							Water jet						
ENGINE															
# Engines		Engine type and horsepower (select one)						Fuel type (select all that apply)							
Manufacturer		Outboard		Sterndrive (I/O)		Inboard		None		Gasoline		Diesel		Electric	
		Total horsepower: hp													
SAFETY MEASURES															
Organizations that have conducted a vessel safety check (VSC) on board your boat within the past year (including carriage of safety equipment, e.g., lifejackets, anchor and line, fire extinguishers):															
US Coast Guard Auxiliary: VSC Decal? <input type="checkbox"/> Yes <input type="checkbox"/> No				Federal Agency (Name)											
US Power Squadrons: VSC Decal? <input type="checkbox"/> Yes <input type="checkbox"/> No				State Agency (Name)											
				Other Agency (Name)											
# Life jackets on board:		# Fire extinguishers on board:		Type of fire extinguishers (e.g., ABC):											
		# Fire extinguishers used:		Amount of fire extinguishers used:											
ACCIDENT DETAILS – EXTERNAL CONDITIONS															
WEATHER															
Overall weather was (select one)				It was (select one)		Visibility was (select one)		Wind was (select one)							
Clear		Raining		Day		Good		0 mph (none)							
Cloudy		Snowing		Night		Fair		Over 0, up to 12 mph (light)							
Foggy		Hazy				Poor		Over 12, up to 25 mph (moderate)							
Other (describe):				Approximate air temperature:		°F		Over 25, up to 55 mph (strong)							
								Over 55 mph (stormy)							
WATER															
Overall water conditions (select one):						Other water conditions:									
Up to 6 in. waves (calm)						Approximate water temperature:				°F					
Over 6 in., up to 2 ft. waves (choppy)						Strong current?				Yes No					
Over 2 ft., up to 6 ft. waves (rough)						Hazardous waters? (e.g., rapid tidal flow, currents)				Yes No					
Over 6 ft. waves (very rough)						Congested waters?				Yes No					

For each question below, please provide answers IF APPLICABLE AND IF KNOWN, otherwise leave blank.			
<b>ACCIDENT DETAILS – ACTIVITIES AND OPERATIONS ON YOUR BOAT</b>			
<b>OPERATOR/PASSENGER ACTIVITIES</b>			
Operator/passenger activities on <i>your</i> boat at time of accident:			
Activities were (select one)		Operator/Passenger activities (select all that apply)	
Recreational	Fishing	Tubing	Starting engine
Commercial	Hunting	Water Skiing	Making repairs
	White water activity (e.g., rafting)	Relaxing	Other (list):
<b>BOAT OPERATIONS</b>			
Your boat operations at time of accident (select all that apply)			
Cruising (underway under power)	Drifting	Racing	Towing another vessel
Changing direction	At anchor	Rowing/paddling	Launching
Changing speed	Being towed	Docking/undocking	Tied to dock/mooring
Sailing	Other (list)		
<b>ACCIDENT DETAILS – CONTRIBUTING FACTORS ON YOUR BOAT</b>			
<b>CONTRIBUTING FACTORS</b>			
Indicate factors on <i>your</i> boat which may have contributed to this accident (select all that apply)			
Alcohol use	Improper lookout	Dam/lock	Starting in gear
Drug use	Operator inattention	Force of wake/wave	Sharp turn
Excessive speed	Operator inexperience	Hazardous waters	Restricted vision (e.g., fog)
Improper anchoring	Language barrier	Heavy weather	Mission/inadequate aids to navigation (e.g., buoy, daymarker)
Improper loading	Navigation rules violation	Ignition of fuel or vapor	Inadequate on-board navigation lights
Overloading	Failure to vent	Hull failure	People on gunwale, bow or transom
Other (describe):			
<b>ACCIDENT DETAILS – YOUR BOAT</b>			
<b>MACHINERY/EQUIPMENT FAILURE</b>			
Failure of the following machinery/equipment on <i>your</i> boat contributed to this accident (select all that apply)			
Engine	Onboard lights	Shift	Sound equipment (e.g., horn, whistle)
Electrical system	Seats	Radio	Auxiliary equipment
Fuel system	Steering	Fire extinguisher	Other (list):
Sail/mast	Throttle	Ventilation	
Onboard navigation aids (e.g., GPS)			
<b>ACCIDENT DETAILS – EVENTS ON YOUR BOAT</b>			
<b>ACCIDENT EVENTS</b>			
Types of events occurring to/on <i>your</i> boat during accident (select all that apply)			
Collision with recreational boat	Flooding/swamping		Person fell overboard
Collision with commercial boat (e.g., tug, barge)	Fire/explosion – fuel		Person fell on/within boat
Collision with fixed object (e.g., dock, bridge)	Fire/explosion – non-fuel		Sudden medical condition
Collision with submerged object (e.g., stump, cable)	Carbon monoxide exposure		Person struck by boat
Collision with floating object (e.g., log, buoy)	Mishap of skier, tuber, wake boarder, etc.		Person struck by propeller or propulsion unit
Capsizing	Person left boat voluntarily		Person electrocuted
Grounding	Person ejected from boat (caused by collision or maneuver)		
Sinking	Other (describe)		

For each question below, please provide answers IF APPLICABLE AND IF KNOWN, otherwise leave blank.

**ACCIDENT DETAILS – YOUR BOAT-  
INJURED PEOPLE RECEIVING OR IN NEED OF TREATMENT BEYOND FIRST AID**

*Report only injured people on, struck by, or being towed by your boat, receiving or in need of treatment beyond first aid. Do not report injured people on, struck by, or being towed by another boat or no boat (e.g., swimmers, people on a dock). If more than one injured person to report, attach additional copies of this page. If none, SKIP INJURED PEOPLE section.*

**INJURED PERSON**

First Name	MI	Last Name
Street		
City	State	Zip
Phone	Date of Birth (mm/dd/yyyy)	Age

**INJURY DETAILS**

Injury caused when person (select all that apply)		Nature of most serious injury (select one)	
Struck the (e.g., boat, water):		Scrape/bruise	Dislocation
Was struck by a (e.g., boat, propeller):		Cut	Internal organ injury
Was exposed to carbon monoxide poisoning		Sprain/strain	Amputation
Received an electric shock		Concussion/brain injury	Burn
Other (describe):		Spinal cord injury	Other (describe):
Person was wearing lifejacket?	Yes <input type="checkbox"/> No <input type="checkbox"/>	Broken/fractured bone	
Person received treatment beyond first aid?	Yes <input type="checkbox"/> No <input type="checkbox"/>	Body part of most serious injury (e.g., head, trunk, leg):	
Person was admitted to a hospital?	Yes <input type="checkbox"/> No <input type="checkbox"/>		

**ACCIDENT DETAILS – YOUR BOAT – DEATHS/DISAPPEARANCES**

*Only report deaths/disappearances of people on, struck by, or being towed by your boat. If more than one death/disappearance to report, attach additional copies of this page. If none, SKIP DEATHS/DISAPPEARANCES section.*

**PERSON WHO DIED/DISAPPEARED**

First Name	MI	Last Name
Street		
City	State	Zip
Phone	Date of Birth (mm/dd/yyyy)	Age

**DETAILS OF DEATH/DISAPPEARANCE**

Injury caused when person (select all that apply)		Nature of death/disappearance (select one)	
Struck the (e.g., boat, water):		Death – by drowning	
Was struck by a (e.g., boat, propeller):		Death – other likely cause (describe)	
Was exposed to carbon monoxide poisoning			
Received an electric shock		Disappeared and not yet recovered	
Other (describe):		Person was wearing lifejacket?	Yes <input type="checkbox"/> No <input type="checkbox"/>

For each question below, please provide answers IF APPLICABLE AND IF KNOWN, otherwise leave blank.

### ACCIDENT DETAILS – YOUR BOAT OPERATOR

OPERATOR INSTRUCTION		OPERATOR SAFETY MEASURES			
Boating safety instruction completed <i>(select all that apply)</i>		On board, prior to accident, was operator wearing:			
<input type="checkbox"/> None		A lifejacket?	<input type="checkbox"/> Yes	<input type="checkbox"/> No	
<input type="checkbox"/> State course		An engine cut-off switch ( <i>Lanyard or wireless device</i> ) if equipped?	<input type="checkbox"/> Yes	<input type="checkbox"/> No	
<input type="checkbox"/> USCG Auxiliary course		On board, prior to accident, was operator using:			
<input type="checkbox"/> US Power Squadrons course		Alcohol?	<input type="checkbox"/> Yes	<input type="checkbox"/> No	
<input type="checkbox"/> Internet <i>(name of sponsoring organization)</i>		Drugs?	<input type="checkbox"/> Yes	<input type="checkbox"/> No	
<input type="checkbox"/> Other <i>(describe)</i>		Operator arrested for Boating Under the Influence?	<input type="checkbox"/> Yes	<input type="checkbox"/> No	
		Weather reports consulted prior to accident?	<input type="checkbox"/> Yes	<input type="checkbox"/> No	

### OPERATOR EXPERIENCE

Experience operating this type of boat *(select one)*

<input type="checkbox"/> 0 to 10 hours	<input type="checkbox"/> Over 10, up to 100 hours	<input type="checkbox"/> Over 100, up to 500 hours	<input type="checkbox"/> Over 500 hours
--	---	--	---

### ACCIDENT DETAILS – OTHER KEY PEOPLE

Only report other key people *not already documented* as injured, died, disappeared or operator/owner of your boat. If more than two other key people to report, attach additional copies of this page.

#### NAME/ADDRESS

This other key person was a(n) *(select all that apply)*

Other boat operator    Other boat owner    Owner of other damaged property    Passenger on your boat    Witness

First Name	MI	Last Name	
Street			
City	State	Zip	Phone
Other boat name <i>(if any)</i>		Other boat registration # <i>(if any)</i>	

#### NAME/ADDRESS

This other key person was a(n) *(select all that apply)*

Other boat operator    Other boat owner    Owner of other damaged property    Passenger on your boat    Witness

First Name	MI	Last Name	
Street			
City	State	Zip	Phone
Other boat name <i>(if any)</i>		Other boat registration # <i>(if any)</i>	

For each question below, please provide answers IF APPLICABLE AND IF KNOWN, otherwise leave blank.					
<b>YOUR BOAT OPERATOR</b>					
<b>NAME/ADDRESS</b>					
First Name		MI	Last Name		
Street					
City		State	Zip		
<b>AGE/GENDER/PHONE</b>					
Date of Birth <i>(mm/dd/yyyy)</i>	Age	Gender	Male	Female	Phone
<b>YOUR BOAT OWNER</b>					
If same as <i>your boat operator</i> SKIP rest of YOUR BOAT OWNER section.					
<b>NAME/ADDRESS/PHONE</b>					
First Name		MI	Last Name		
Street					
City		State	Zip	Phone	
<b>PERSON SUBMITTING THIS REPORT</b>					
If same as <i>your boat operator</i> OR <i>owner</i> , SKIP rest of PERSON SUBMITTING THIS REPORT section.					
<b>NAME/ADDRESS/PHONE/ROLE</b>					
First Name		MI	Last Name		
Street					
City		State	Zip	Phone	
<b>I was a(n) (select one)</b>					
<input type="checkbox"/>	Other person on board <i>this</i> boat				
<input type="checkbox"/>	Accident witness <i>not</i> on board <i>this</i> boat				
<input type="checkbox"/>	Other ( <i>describe</i> ):				
<b>SIGNATURE OF PERSON SUBMITTING THIS REPORT</b>					
Your signature				Date (mm/dd/yyyy)	
<p>An Agency may not conduct or sponsor and a person is not required to respond to an information collection, unless it displays a currently valid OMB Control Number.</p> <p>The Coast Guard estimates that the average burden for this report form is 30 minutes. You may submit any comments concerning the accuracy of this burden estimate or any suggestions for reducing the burden to: Commandant (CG-BSX-21), U.S. Coast Guard, Washington, DC 20593-0001 or Office of Management and Budget, Paperwork Reduction Project (1625-0003), Washington, DC 20503.</p>					







# Navigational Aids Chart

## REMEMBER THESE RULES

1. OVERTAKING - PASSING: Boat being passed has the right-of-way. **KEEP CLEAR.**
2. MEETING HEAD ON: Keep to the right.
3. CROSSING: Boat on right has the right-of-way. Slow down and permit boat to pass.

<p><b>← PORT</b></p> <p>Yield right-of-way to boats in your DANGER ZONE!</p>  <p><b>STARBOARD →</b></p> <p>DANGER ZONE (Dead ahead to 2 points abaft your starboard beam)</p>	<h3>STORM WARNINGS</h3>  <p><b>RED FLAG</b> Small craft (winds to 33 knots)</p> <p><b>2 RED FLAGS</b> Gale (winds up to 47 knots)</p> <p><b>SQUARE RED FLAG BLACK BOX</b> (Storm)</p> <p><b>2 SQUARE RED FLAGS BLACK BOX</b> (Hurricane)</p>																								
<h3>WHISTLE SIGNALS</h3> <p><b>ONE LONG BLAST:</b> Warning signal (Coming out of slip)</p> <p><b>ONE SHORT BLAST:</b> Pass on my port side</p> <p><b>TWO SHORT BLASTS:</b> Pass on my starboard side</p> <p><b>THREE SHORT BLASTS:</b> Engine(s) in reverse</p> <p><b>FIVE OR MORE BLASTS:</b> Danger signal</p>	<h3>BRIDGE SIGNALS</h3> <table border="0"> <tr> <td><b>SOUND</b></td> <td><b>VISUAL</b></td> <td>DAY (Flag)</td> <td>NIGHT (Lights)</td> </tr> <tr> <td>VESSEL: Open — ●</td> <td>VESSEL: Open</td> <td>↕</td> <td>↕</td> </tr> <tr> <td>BRIDGE: OK — ●</td> <td>BRIDGE: OK</td> <td>↕</td> <td>↕</td> </tr> <tr> <td>No ●●●●●</td> <td>No</td> <td>↕</td> <td>↕</td> </tr> <tr> <td>VESSEL: Replies: ●●●●●</td> <td></td> <td></td> <td></td> </tr> <tr> <td><b>RADIO: VHF CH. 13</b></td> <td></td> <td></td> <td></td> </tr> </table>	<b>SOUND</b>	<b>VISUAL</b>	DAY (Flag)	NIGHT (Lights)	VESSEL: Open — ●	VESSEL: Open	↕	↕	BRIDGE: OK — ●	BRIDGE: OK	↕	↕	No ●●●●●	No	↕	↕	VESSEL: Replies: ●●●●●				<b>RADIO: VHF CH. 13</b>			
<b>SOUND</b>	<b>VISUAL</b>	DAY (Flag)	NIGHT (Lights)																						
VESSEL: Open — ●	VESSEL: Open	↕	↕																						
BRIDGE: OK — ●	BRIDGE: OK	↕	↕																						
No ●●●●●	No	↕	↕																						
VESSEL: Replies: ●●●●●																									
<b>RADIO: VHF CH. 13</b>																									

## LATERAL AIDS AS SEEN ENTERING FROM SEAWARD

<h3>PORT SIDE ODD NUMBERED AIDS</h3> <p><b>GREEN LIGHT ONLY</b></p> <p>FLASHING </p> <p>OCCULTING </p> <p>QUICK FLASHING </p> <p>ISOPHASE </p> <p><b>LIGHTED BUOY</b> G "B" Fl G 4sec</p> <p><b>CAN</b> G C "7"</p> <p><b>DAYMARK</b> SG 1 G "1"</p>	<h3>SAFE WATER MID-CHANNELS OR FAIRWAYS NO NUMBERS — MAY BE LETTERED</h3> <p>Mo (A) <input type="checkbox"/> WHITE LIGHT ONLY <input type="checkbox"/> MORSE CODE <input type="checkbox"/></p> <p><b>SPHERICAL</b> RW SP "G"</p> <p><b>MINOR</b> RW "A"</p> <p><b>LIGHTED AND OR SOUND</b> RW "B" Mo (A)</p> <h3>PREFERRED CHANNEL</h3> <p>COMPOSITE GROUP FLASHING (2 + 1)</p> <p><b>GREEN LIGHT ONLY</b></p> <p>GR "C" Fl (2 + 1)</p> <p><b>PREFERRED CHANNEL TO STARBOARD TOPMOST BAND GREEN</b></p> <p>GR C "L"</p> <p><b>RED LIGHT ONLY</b></p> <p>RG "B" Fl (2 + 1)</p> <p><b>PREFERRED CHANNEL TO PORT TOPMOST BAND RED</b></p> <p>RG "W"</p> <p><b>JR</b> B</p> <p>RG "R"</p>	<h3>STARBOARD SIDE EVEN NUMBERED AIDS</h3> <p><b>RED LIGHT ONLY</b></p> <p>FLASHING </p> <p>OCCULTING </p> <p>QUICK FLASHING </p> <p>ISOPHASE </p> <p><b>LIGHTED BUOY</b> R "B" Fl R 4sec</p> <p><b>NUN</b> R N "6"</p> <p><b>DAYMARK</b> TR 2 R "2"</p>
--	---	--

