

 **FOUR WINNS®**

**FREEDOM/HORIZON OWNERS MANUAL**



# SPORT BOATS

<https://www.boat-manuals.com/>



FOUR WINNS L.L.C., 925 Frisbie Street, Cadillac, MI 49601 Phone (231) 775-1343

## WARRANTY REGISTRATION TRANSFER REQUEST

Original Owner Name & Address: \_\_\_\_\_

\_\_\_\_\_

\_\_\_\_\_

Original Date of Purchase: \_\_\_\_\_

Hull Identification Number: \_\_\_\_\_

Boat Model: \_\_\_\_\_

Selling Dealer: \_\_\_\_\_

Name and address of new purchaser: \_\_\_\_\_

\_\_\_\_\_

\_\_\_\_\_

Telephone & E-Mail Address: \_\_\_\_\_

Date of Purchase: \_\_\_\_\_

Transfer Fee\*: \$100.00 – All models.

The warranty may be transferred only once. Registration of the second owner is required and the amount of the transfer fee is \$100.00. Transfer of the remainder of the warranty must occur within five (5) years of the original retail sale. The transfer fee must be paid within fifteen (15) days of purchase of the used boat by check, money order or cashier's check payable to Four Winns. We will notify the appropriate engine manufacturer of the boat warranty transfer.

This warranty registration request if accepted, transfers the warranty coverage remaining on the boat to the new purchaser. Acceptance of this request does not create any additional warranties or obligation on Four Winns.

Warranty Expiration Date: \_\_\_\_\_

Four Winns Transfer Acceptance Date: \_\_\_\_\_

Four Winns Authorized Signature: \_\_\_\_\_

Mail to Four Winns L.L.C., 925 Frisbie Street, Cadillac, MI 49601, Attn: Customer Service Department.

**\*Subject to change without notice.**



FOUR WINNS

# NAME / ADDRESS CHANGE FORM

Name & Address:

\_\_\_\_\_  
PLEASE PRINT CLEARLY.

\_\_\_\_\_  
\_\_\_\_\_

Telephone & E-Mail Address:

\_\_\_\_\_

Hull Identification Number:

\_\_\_\_\_

Boat Model:

\_\_\_\_\_

Date of Purchase:

\_\_\_\_\_

**NOTE:** For warranty transfer please use the Warranty Transfer Request Form also included in front of manual.

PLEASE FOLD IN HALF & SEAL.



FOUR WINNS

# NAME / ADDRESS CHANGE FORM

Name & Address:

\_\_\_\_\_  
PLEASE PRINT CLEARLY.

\_\_\_\_\_  
\_\_\_\_\_

Telephone & E-Mail Address:

\_\_\_\_\_

Hull Identification Number:

\_\_\_\_\_

Boat Model:

\_\_\_\_\_

Date of Purchase:

\_\_\_\_\_

**NOTE:** For warranty transfer please use the Warranty Transfer Request Form also included in front of manual.

PLEASE FOLD IN HALF & SEAL.



FOUR WINNS

# NAME / ADDRESS CHANGE FORM

Name & Address:

\_\_\_\_\_  
PLEASE PRINT CLEARLY.

\_\_\_\_\_  
\_\_\_\_\_

Telephone & E-Mail Address:

\_\_\_\_\_

Hull Identification Number:

\_\_\_\_\_

Boat Model:

\_\_\_\_\_

Date of Purchase:

\_\_\_\_\_

**NOTE:** For warranty transfer please use the Warranty Transfer Request Form also included in front of manual.

PLEASE FOLD IN HALF & SEAL.

TO: Four Winns L.L.C.  
925 Frisbie Street  
Cadillac, MI 49601

**Attn: Customer Service Department.**

PLEASE  
PLACE  
STAMP  
HERE.

TO: Four Winns L.L.C.  
925 Frisbie Street  
Cadillac, MI 49601

**Attn: Customer Service Department.**

PLEASE  
PLACE  
STAMP  
HERE.

TO: Four Winns L.L.C.  
925 Frisbie Street  
Cadillac, MI 49601

**Attn: Customer Service Department.**

PLEASE  
PLACE  
STAMP  
HERE.

# PREFACE

This manual will acquaint you with the use and maintenance of your new Four Winns boat. This manual also provides special information critical to the safety of the passengers, and longevity of the equipment. The information on the following page lists the graphics used to increase the visibility of these important messages. Also included in your owner's packet is the "Boating Basics, A Guide to Responsible Boating". This publication covers the boating basics and should be read along with your Four Winns Owner's Manual before operating your boat. Review this information completely before using your new boat.

Four Winns continually strives to improve its products. Unit specifications, including standard and optional equipment are constantly being modified. **Equipment availability is also subject to change. The most current and accurate information available at the time of publication is included in this manual. Some variation in equipment, description, location, and details can result.**

The information in this manual focuses upon the equipment designed and manufactured by Four Winns on specific models. When appropriate, please utilize the information pertinent to your specific boat model.

Equipment such as engines, and other accessories are manufactured by others. **The information provided in this manual is intended to be used in conjunction with the information provided by the manufacturers of this equipment.** All information available at the time of manufacture has been included with your owner's packet. In many cases, replacement of manufacturer's literature may be obtained via their respective Internet website.

**Read this entire manual carefully before operating your new boat.** Many instructions may require direct performance of the activity to fully understand the correct method. If you choose to read this manual at home, remember to take it to the boat with you.

Your Four Winns dealer knows your boat best and is interested in your complete satisfaction. Return to the dealer for service or other assistance. If you find it necessary to contact Four Winns directly, please refer to the address information listed below. Be sure to include the boat model, hull identification number, your daytime telephone number, and specifics of the information desired.

This manual has been specifically developed for the Freedom™ and Horizon™ models. Please record the model and hull identification number information below.

**Model**

**Hull Identification Number**

---



---

This manual should be considered part of the boat. Should you sell the boat, pass this manual on to the new owner. Take special care of this manual. Certain information in this manual may not be available in a replacement manual. An electronic version of this manual may be viewed on our website at [www.fourwinns.com](http://www.fourwinns.com).

Thank you for joining the Four Winns family. We appreciate your purchase and welcome the opportunity to demonstrate our commitment to you.

**Four Winns Customer Service Department**  
**925 Frisbie Street**  
**Cadillac, Michigan 49601**  
**231-775-1343 (Phone)**  
**231-779-2345 (FAX)**  
**E-Mail Address: [boating@fourwinns.com](mailto:boating@fourwinns.com)**  
**©FOUR WINNS L.L.C. 2004. All Rights Reserved.**

Congratulations on your new boat purchase and welcome to our boating family!

We want your boating experience to be the most enjoyable possible. The more you know about your new boat, the more you'll enjoy the time you spend aboard. That's why we prepared this manual. It's your guide for safe operation as well as understanding your boat's system and equipment. It has been written for the beginning boater but experienced boaters will find helpful information as well. Be sure to read the contents thoroughly.

The popularity of boating and other water sports has grown tremendously in the past few years. Because of this, safety is an important issue for everyone who shares our waterways.

Remember that along with the freedom and exhilaration of boating comes the responsibility that you have for the safety of your passengers and the other boaters who share the water with you. Throughout this manual, specific precautions and symbols identify safety-related information. Be sure to pay close attention to them.

 This symbol means "pay attention!" Here is important information for your safety. If you don't follow these instructions, you can damage your boat, hurt yourself or someone else or, even worse, have a fatal accident.

 **CAUTION**

This symbol and signal word indicate a potentially hazardous situation. If you ignore this safety message, property damage or minor or moderate personal injury MAY or CAN result.

 **WARNING**

This symbol and signal word indicate a potential hazard. If you ignore this safety message, serious injury or death CAN result.

 **DANGER**

This symbol and signal word indicates an immediate hazard. If you ignore this safety message, serious personal injury or death WILL result.

**IMPORTANT HEALTH AND SAFETY INFORMATION ABOUT YOUR NEW BOAT**

 **CAUTION**

WARNING: Engine exhaust, some of its constituents, and a wide variety of components contain or emit chemicals known to the State of California to cause cancer and birth defects and other reproductive harm. In addition, oils, fuels and fluids contained in boats as well as waste produced by component wear contain or emit chemicals known to the State of California to cause cancer and birth defects or other reproductive harm.

Battery posts, terminals and related accessories contain lead and lead compounds. Wash your hands after handling. Used engine oil contains chemicals that have caused cancer in laboratory animals. Always protect your skin by washing thoroughly with soap and water.

The precautions in this manual can't and don't cover every boating situation. If a specific method or procedure is not recommended, you must make sure that what you do is safe for you and others. Always use common sense when boating! Remember to make sure that every safe boating excursion is a happy experience.



We'd also like to remind you to be kind to our environment while you're boating. Don't throw garbage and other refuse overboard. Do your best to keep harmful compounds like gasoline, oil and antifreeze out of the water. Please see the notifications below:





**DISCHARGE OF OIL PROHIBITED**

**THE FEDERAL WATER POLLUTION CONTROL ACT PROHIBITS THE DISCHARGE OF OIL OR OILY WASTE INTO OR UPON THE NAVIGABLE WATERS OF THE UNITED STATES, OR THE WATERS OF THE CONTIGUOUS ZONE, OR WHICH MAY EFFECT NATURAL RESOURCES BELONGING TO, APPERTAINING TO, OR UNDER THE EXCLUSIVE MANAGEMENT AUTHORITY OF THE UNITED STATES, IF SUCH DISCHARGE CAUSES A FILM OR DISCOLORATION OF THE SURFACE OF THE WATER OR CAUSES A SLUDGE OR EMULSION BENEATH THE SURFACE OF THE WATER. VIOLATORS ARE SUBJECT TO SUBSTANTIAL CIVIL PENALTIES AND/OR CRIMINAL SANCTIONS INCLUDING FINES AND IMPRISONMENT.**

Oil Discharge Plate - (Specific Models Only - Location Not Shown)

*It is illegal for any vessel to dump plastic trash anywhere in the ocean or navigable waters of the United States. Annex V of the MARPOL TREATY is an*

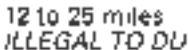
*International Law for a cleaner, safer marina environment. Violation of these requirements may result in civil penalty up to \$25,000, fine and imprisonment.*

			
<p>U.S. Lakes, Rivers, Bays, Sounds and 3 miles from shore <b>ILLEGAL TO DUMP Plastic &amp; Garbage</b></p> <p>Paper    Metal Rags    Crockery Glass    Dunnage Food</p>	<p><b>3 to 12 miles ILLEGAL TO DUMP Plastic</b></p> <p>Dunnage, lining &amp; packing materials that float, also if not ground to less than one inch:</p> <p>Paper    Crockery Rags    Metal Glass    Food</p>	<p><b>12 to 25 miles ILLEGAL TO DUMP Plastic</b></p> <p>Dunnage, lining &amp; packing materials that float</p>	<p>Outside 25 miles <b>ILLEGAL TO DUMP Plastic</b></p>

**State and local regulations may further restrict the disposal of garbage.**

Trash Overboard Decal - (Specific Models Only - Location Not Shown)

The information contained in the owner's packet has been compiled to help you operate your boat with safety and pleasure. It contains the details of the boat, the equipment supplied or fitted, its systems, and information on its operation and maintenance. Please read the information carefully and familiarize yourself with the boat before using it.

If this is your first boat, or if you are changing to a type of boat you are not familiar with, for your own comfort and safety, please ensure that you obtain handling and operating experience before "assuming command" of the boat. Your dealer or national sailing federation or yacht club will be pleased to advise you of local sea schools and competent instructors.

PLEASE KEEP THE MANUAL AND ALL OTHER PERTINENT INFORMATION IN A SECURE PLACE, AND HAND IT OVER TO THE NEW OWNER WHEN YOU SELL THE BOAT.

**LABEL LOCATIONS**

The NMMA capacity label and various warning labels are placed at different locations on each model for your safety. Additional warnings for fuel leakage, blower operation, and other important information will be imprinted or located on the dash. Many of these stickers and labels are not required by the U.S. Coast Guard but are important to ensure the safe operation of your Four Winns® boat. In addition, the Hull Identification Number plate is permanently attached below the deck-hull joint on the starboard aft corner.

Below are letters corresponding to the various locations for each label depicted. Please note that actual locations may vary depending on which model you have. See the following pages for the actual wording of each of the various warning labels found on your boat.

- (A) Helm Boarding Ladder Warning (Imprinted)
- (B) Gasoline Vapor-Blower Warning (Imprinted)
- (C) Rotating Prop - Boarding Ladder (Bow & Stern)
- (D) Aft Lounge CO Warning Label
- (E) Leaking Fuel
- (F) Rotating Propeller - Helm
- (G) CO Swim Platform & Lounging Areas
- (H) Capacity Label/Yacht Certification Plate
- (I) Ski Tow Warning
- (J) Winning Edge Sticker
- (K) NMMA Certified
- (L) Do Not Occupy Platform Warning Label
- (M) Hull Identification Number Plate

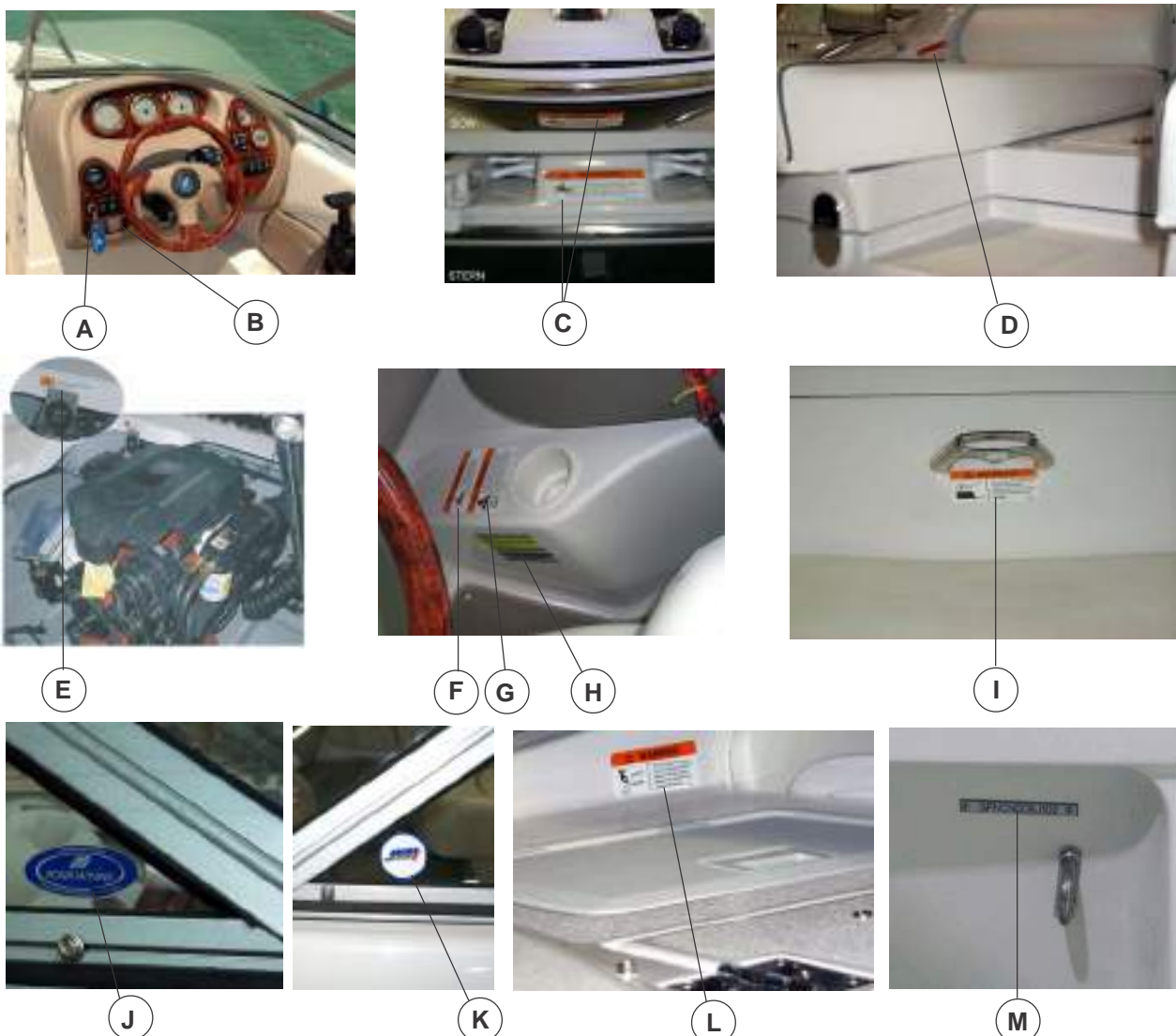

**Figure 1: Freedom™/Horizon™ Models - Warning, Capacity and Other Label Locations (Reference Only)**



CAPACITY & WARNING LABELS

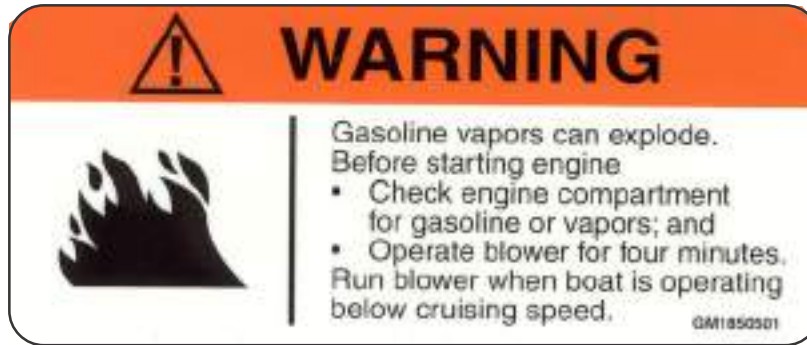

A. Gasoline Vapor-Blower Warning Label



Imprinted Labels on Port Ignition Panel



A. **GASOLINE VAPORS CAN EXPLODE RESULTING IN INJURY OR DEATH. BEFORE STARTING ENGINE -CHECK ENGINE BILGE COMPARTMENT FOR GASOLINE OR VAPORS, AND -OPERATE BLOWER FOR FOUR MINUTES, AND VERIFY BLOWER OPERATION. RUN BLOWER WHEN VESSEL IS OPERATING BELOW CRUISING SPEED.**



B. **ROTATING PROPELLER CAN CAUSE SERIOUS INJURY OR DEATH. SHUT OFF MOTOR WHEN NEAR PERSONS IN WATER.**



C. & D. Rotating Propeller - Ladder Warning Label



E. Leaking Fuel Warning Label

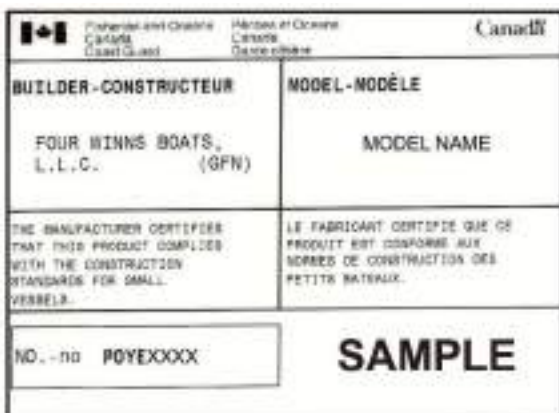

F. Canadian Conformity Label

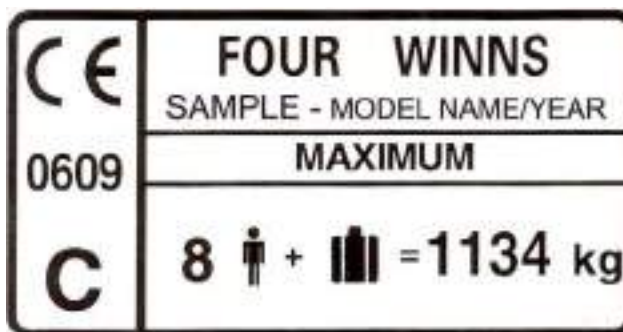

F. EU Builders Plate-CE Certification Plate (Export)



G. SAMPLE - Capacity Label (See Actual Capacity Plate Affixed to Boat for Actual Capacities.



G. NMMA Yacht Certification Plate Replaces Capacity Label on Certain Specific Models Only.

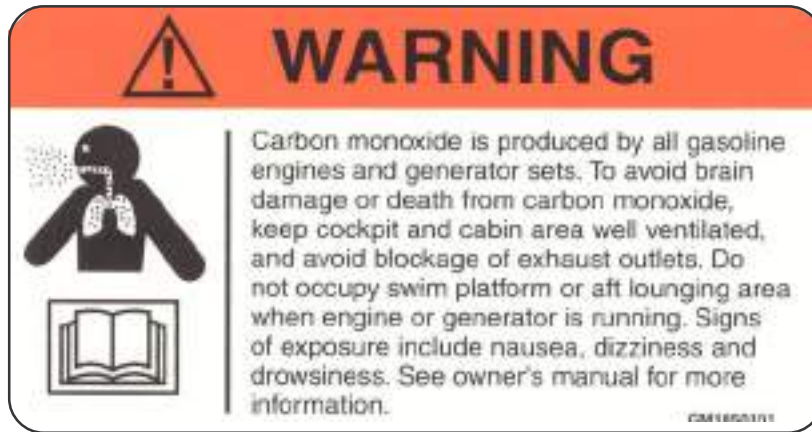

H. CO Swim Platform & Lounging Area Warning Label



I. Rotating Propeller - Helm Warning Label



J. Ski Tow Warning Label



K. Winning Edge Sticker



L. NMMA Certified Sticker



M. SAMPLE - Hull Identification Number



Flush Out Warning Label (w/ Option)  
Location Not Shown



ADDITIONAL LABELS (LOCATIONS NOT SHOWN)

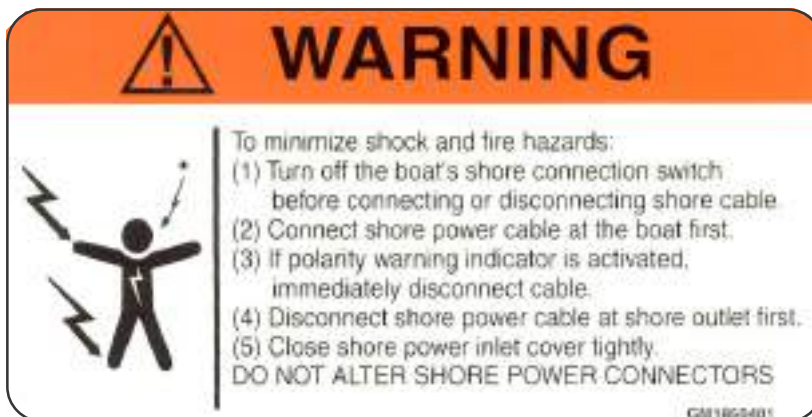

Shore Power Inlet Warning Label



No Ventilation - Do Not Store Fuel Warning Label



Transom/Side Door Warning Label



Do Not Occupy Platform Warning Label

ADDITIONAL LABELS CONTINUED (SPECIFIC MODELS ONLY-LOCATIONS NOT SHOWN)

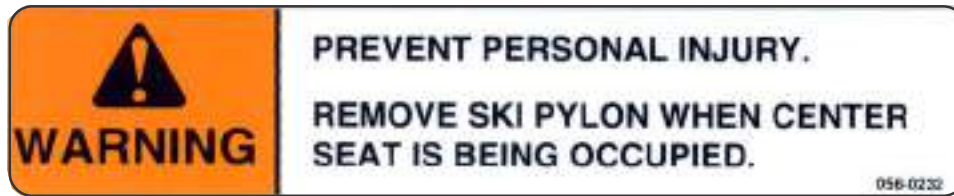

Remove Ski Pylon Warning Label

# TABLE OF CONTENTS

<b>OPERATION .....</b>	<b>1</b>
A - 1    GENERAL .....	1
A - 2    COMPONENT SYSTEMS .....	1
A - 3    SAFETY EQUIPMENT .....	1
A - 4    PASSENGER SAFETY .....	1
A - 5    "RULES OF THE ROAD" .....	1
A - 6    LIGHTNING .....	1
A - 7    DRUGS AND ALCOHOL .....	2
A - 8    PRE-CRUISE SYSTEM CHECK .....	2
A.    Before Starting The Engine .....	2
B.    After Starting The Engine .....	2
A - 9    ENGINE OPERATIONAL PROCEDURES .....	2
A.    Before Starting .....	2
B.    Cold Engine Start (Carbureted Engines) .....	3
C.    Warm Engine Starting (Carbureted Engines) .....	3
D.    Cold / Warm Engine Start (EFI Engines) .....	3
E.    Shifting and Control Speed .....	4
F.    Stopping Engine .....	4
A - 10   GROUNDING AND TOWING .....	5
A - 11   BOATING EDUCATION .....	5
A.    Boating Courses .....	5
B.    Boating Manuals or Literature .....	5
C.    Charts and Maps .....	5
D.    Laws and Regulations .....	6
A - 12   BOAT OWNER REGISTRATION .....	6
A - 13   INSURANCE .....	6
A - 14   ACCIDENT REPORTING .....	6
A - 15   DISCHARGE OF OIL .....	7
A - 16   DISPOSAL OF PLASTICS & OTHER GARBAGE .....	7
A - 17   MARPOL TREATY .....	7
<b>SAFETY &amp; SAFETY EQUIPMENT .....</b>	<b>1</b>
B - 1    GENERAL .....	1
A.    Required Safety Equipment .....	1
B.    Personal Floatation Devices (PFD's) .....	1
C.    PFD Types .....	1
D.    PFD Pointers .....	2
E.    Fire Extinguisher .....	2
F.    Fire Extinguisher System .....	3
G.    Visual Distress Signal Devices .....	3
H.    Sound Signaling Devices .....	4
I.    Navigation Lights .....	4
J.    Additional Recommended Equipment .....	4
B - 2    CARBON MONOXIDE .....	4
A.    Properties and Characteristics of Carbon Monoxide .....	4
B.    What Makes Carbon Monoxide .....	5



	C.	How a Person is Affected by Carbon Monoxide .....	5
	D.	Effects of Carbon Monoxide .....	5
	E.	Symptoms .....	5
	F.	Treatment (Evaluate, Ventilate, Evacuate, Investigate, Take Corrective Action) ..	5
	G.	Inspection .....	6
	H.	Operation .....	6
	I.	Boathouses, Sea Walls and Confined Spaces .....	6
	J.	The Effect of Boats Moored Along Side .....	6
	K.	Backdrafting (Station Wagon Effect) .....	7
	L.	Accumulation of Exhaust Gases-Swim Platform .....	8
	M.	Dangerous Activity - "Teak Surfing"/"Dragging" .....	8
	N.	Cabin Appliances .....	8
	O.	Ventilation of Accommodation (Occupied) Spaces .....	8
	P.	Running of Engines in Idle .....	8
	Q.	Altitude and Sea Conditions .....	8
	R.	Portable Generator Sets .....	9
	S.	Maintenance - Engine Performance .....	9
	T.	Maintenance - External Conditions .....	9
	U.	Maintenance - Exhaust Systems Integrity .....	9
	V.	Maintenance - Ventilation Systems .....	10
	W.	Maintenance - Bulkhead and Deck Integrity .....	10
	X.	Maintenance - Liquid Drains .....	10
B - 3		<b>SAFE BOATING PRACTICES .....</b>	<b>10</b>
	A.	Drugs and Alcohol .....	10
	B.	Safe Operation .....	10
	C.	Passenger Safety .....	11
	D.	Propeller .....	11
	E.	First Aid .....	11
	F.	Operation By Minors .....	11
	G.	"Rules of the Road" .....	11
	H.	Voluntary Inspection .....	12
	I.	Safe Boating Courses .....	12
B - 4		<b>WATER SPORTS .....</b>	<b>12</b>
	A.	Water Sport Guidelines .....	12
	B.	Water Skiing .....	13
		<b>BASIC SEAMANSHIP .....</b>	<b>1</b>
C - 1		<b>GENERAL</b>	
	A.	Boating Regulations .....	1
	B.	Rules of Seamanship .....	1
C - 2		<b>NAVIGATIONAL AIDS .....</b>	<b>3</b>
	A.	International Association of Lighthouse Authorities System B (IALA-B) .....	3
	B.	Lateral Markers .....	3
	C.	Safe Water Markers .....	3
	D.	The Uniform State Waterway Marking System .....	4
	E.	A Special Sign .....	4
	F.	Noise .....	4
	G.	Anchoring .....	4
C - 3		<b>RECOMMENDED READING .....</b>	<b>5</b>
C - 4		<b>CONTACTS .....</b>	<b>5</b>
C - 5		<b>OWNER'S LOGS AND RECORDS .....</b>	<b>6</b>
C - 6		<b>NAVIGATIONAL AIDS CHART .....</b>	<b>6</b>

<b>WARRANTY AND SERVICE .....</b>	<b>1</b>
D - 1    FOUR WINNS WARRANTY POLICY .....	1
D - 2    DECK/HULL STRUCTURE WARRANTY .....	1
D - 3    WARRANTY REGISTRATION .....	1
D - 4    TRANSFER OF WARRANTY .....	1
D - 5    PRE-OWNED UNIT REGISTRATION .....	1
D - 6    INSURANCE COVERAGE .....	2
D - 7    SERIAL NUMBER RECORD .....	2
D - 8    PRE-DELIVERY SERVICE .....	2
D - 9    REPLACEMENT PARTS .....	2
D - 10   OWNER'S RESPONSIBILITIES .....	3
D - 11   CONSTRUCTION STANDARDS .....	3
D - 12   WINNGEAR™ .....	3
 <b>ENGINES AND INSTRUMENTATION .....</b>	 <b>1</b>
E - 1    GENERAL .....	1
E - 2    ENGINE EXHAUST .....	1
E - 3    ENGINES .....	2
E - 4    PROPELLERS .....	2
A.    Diameter .....	2
B.    Pitch .....	2
C.    Prop Slip .....	2
E - 5    RUNNING ANGLE & POWER TRIM/TILT .....	3
A.    Power Trim .....	3
B.    Power Tilt .....	3
E - 6    TRIM TABS .....	3
A.    Control Listing .....	4
B.    Induce Planing & Controlling Trim Angle .....	4
C.    Trim Tab Maintenance .....	5
E - 7    ENGINE INSTRUMENTATION .....	5
A.    Tachometer .....	5
B.    Speedometer .....	6
C.    Temperature Gauge (4-in-1 Gauge) .....	6
D.    Oil Pressure Gauge (4-in-1 Gauge) .....	6
E.    Voltmeter (4-in-1 Gauge) .....	7
F.    Fuel Gauge (4-in-1 Gauge) .....	7
G.    Power Trim Gauge .....	7
H.    Depth Sounder .....	7
I.    Four Position Ignition Switch .....	7
J.    Emergency Stop Switch .....	7
K.    Engine Hour Meter .....	8
L.    Alarm Systems .....	8
M.    VHF Radio - (Optional) .....	8
N.    Compass .....	8
O.    Fish Finder .....	9
P.    Instrument Maintenance .....	9

<b>CONTROL SYSTEMS .....</b>	<b>1</b>
F - 1    GENERAL .....	1
F - 2    SIDE MOUNT CONTROL OPERATION .....	1
A.    Carbureted Engines .....	1
B.    Fuel Injected Engines (EFI) .....	2
F - 3    NEUTRAL SAFETY SWITCH .....	2
F - 4    CONTROL SYSTEM MAINTENANCE .....	2
<b>STEERING SYSTEMS .....</b>	<b>1</b>
G - 1    GENERAL .....	1
A.    Rotary Steering .....	1
B.    Tilt Steering .....	1
C.    Power Steering .....	1
D.    Hydraulic Steering .....	2
G - 2    PROPELLER TORQUE .....	2
G - 3    STEERING SYSTEM MAINTENANCE .....	3
A.    General Maintenance .....	3
B.    Rotary System Maintenance .....	3
C.    Hydraulic System Maintenance .....	3
D.    Winter Storage .....	3
<b>ELECTRICAL SYSTEMS .....</b>	<b>1</b>
H - 1    GENERAL .....	1
H - 2    BATTERY SYSTEM .....	1
A.    Single Battery System .....	1
B.    Dual Battery System .....	1
C.    Battery Switch Operation .....	2
D.    Battery Switch Operation with "Emergency Start Only" Position .....	3
E.    Battery Charger .....	3
H - 3    F.    Fish & Ski Package .....	3
12 VOLT ELECTRICAL EQUIPMENT .....	4
A.    Helm Equipment .....	4
B.    Installation of Additional 12 Volt Equipment .....	5
C.    Interior Equipment .....	5
H - 4    110(220) VOLT ELECTRICAL SYSTEM .....	5
H - 5    DOCKSIDE OPERATION .....	6
A.    Shore Power Connections .....	6
B.    110 Volt AC Equipment .....	7
C.    Reverse Polarity .....	7
D.    Ground Fault Current Interrupters (GFCI) .....	8
H - 6    ELECTRICAL SYSTEM MAINTENANCE .....	8
A.    Battery Maintenance .....	8
B.    Electrical Wiring Maintenance .....	8
H - 7    STRAY CURRENT CORROSION .....	9
A.    General .....	9
B.    Galvanic Corrosion .....	10
C.    Corrosion Prevention .....	10

<b>FUEL SYSTEMS .....</b>	<b>1</b>
I - 1 <b>GASOLINE FUEL SYSTEMS .....</b>	<b>1</b>
A.    System Testing .....	1
B.    Fuel Fills .....	1
C.    Anti-Syphon Valves .....	2
D.    Fuel Gauge .....	2
E.    Fuel Senders .....	2
F.    Fuel Filters .....	3
G.    Use and Maintenance .....	3
I - 2 <b>FUEL STANDARDS .....</b>	<b>3</b>
A.    Problems With Alcohol in Gasoline .....	3
B.    Recommendations .....	4
I - 3 <b>FUELING INSTRUCTIONS .....</b>	<b>4</b>
 <b>WASTE AND WATER SYSTEMS .....</b>	 <b>1</b>
J - 1 <b>GENERAL .....</b>	<b>1</b>
J - 2 <b>DISINFECTING THE WATER SYSTEM .....</b>	<b>1</b>
J - 3 <b>FRESH WATER SYSTEMS .....</b>	<b>2</b>
A.    Head Sink .....	2
B.    Cockpit Refreshment Center .....	2
C.    Transom Washdown .....	3
J - 4 <b>HEADS .....</b>	<b>3</b>
A.    Enclosed Heads .....	3
B.    Porta Potti .....	3
C.    Vacu-Flush® Sanitation System .....	4
D.    Head Pump Out .....	5
J - 5 <b>GRAY WATER SYSTEM - OPTIONAL .....</b>	<b>6</b>
J - 6 <b>LIVEWELL .....</b>	<b>6</b>
J - 7 <b>SYSTEM MAINTENANCE .....</b>	<b>6</b>
A.    Clean Vents and Screens .....	6
B.    Winterizing the Water System .....	7
 <b>VENTILATION AND DRAINAGE SYSTEMS .....</b>	 <b>1</b>
K - 1 <b>ENGINE COMPARTMENT VENTILATION .....</b>	<b>1</b>
A.    Gravity Ventilation System .....	1
B.    Forced Air Ventilation .....	1
C.    Engine Ventilation System Maintenance .....	1
K - 2 <b>HULL DRAINAGE SYSTEMS .....</b>	<b>1</b>
A.    Transom Drain .....	1
B.    Bilge Pumps .....	1
C.    Liner Drains .....	2
D.    Bilge Compartment Drainage .....	2
 <b>INTERIOR EQUIPMENT .....</b>	 <b>1</b>
L - 1 <b>COCKPIT REFRESHMENT CENTER .....</b>	<b>1</b>
L - 2 <b>GLOVEBOX OR STORAGE COMPARTMENT .....</b>	<b>1</b>
L - 3 <b>IN-DASH COOLER .....</b>	<b>1</b>
L - 4 <b>REMOVABLE COOLER .....</b>	<b>2</b>
L - 5 <b>HEADS .....</b>	<b>2</b>

L - 6	STEREO .....	2
L - 7	BURLWOOD HELM ENHANCEMENTS .....	2
L - 8	ANCHOR STORAGE OR ANCHOR LOCKER .....	2
L - 9	SKI STORAGE LOCKER .....	3
L - 10	AFT DECK STORAGE LOCKER(S) & SUNDECK COMPARTMENTS .....	3
L - 11	BOW STORAGE .....	4
L - 12	HELM STORAGE .....	4
L - 13	BOW FILL-IN CUSHIONS .....	4
L - 14	WALK-THRU DOORS .....	5
L - 15	AFT FILL-IN CUSHIONS (U-WRAP OR C-WRAP SEATING) .....	5
L - 16	ADDITIONAL COCKPIT STORAGE .....	5
L - 17	PORT SETTEE LOUNGER .....	5
L - 18	INTEGRATED TACKLE BOX & LIVEWELL (FISH & SKI STERN DRIVES) .....	6
L - 19	COCKPIT TABLES .....	6
<b>EXTERIOR EQUIPMENT .....</b>		<b>1</b>
M - 1	RAILS & DECK HARDWARE .....	1
	A. Rails .....	1
	B. Cleats .....	1
	C. Transom Ski Tow Ring .....	1
	D. Stainless Steel Package Option .....	2
	E. Maintenance .....	2
M - 2	WINDSHIELDS .....	2
M - 3	EXTENDED SWIM PLATFORM - LADDER .....	3
M - 4	COCKPIT AFT FILL-IN BACKREST (DOOR) .....	4
M - 5	ANCHOR & ANCHORING .....	4
M - 6	BOW ROLLER .....	5
M - 7	WINDLASS OPTION .....	5
M - 8	DOCKING LIGHTS .....	6
M - 9	THRU-HULL EXHAUST .....	6
M - 10	WAKEBOARD TOWER .....	7
<b>UPHOLSTERY .....</b>		<b>1</b>
N - 1	SEATING .....	1
	A. Bow Seating .....	1
	B. Loungers .....	1
	C. Aft Fill-In Seating .....	2
	D. Bucket Seats .....	2
	E. Double-Wide Helm Seat .....	3
	F. Stern (Jump) Seats .....	3
	G. Outboard Stern Seating .....	4
	H. Fish & Ski Seating .....	4
	I. Stern Drive Fish & Ski Aft Seating .....	4
	J. Top Storage .....	5
	K. Sundeck (SunSport Seating Option) .....	5
	L. SunSport Lounge Seat .....	6
	M. Engine Cover (Motorhood) .....	7
	N. Engine Hatch with Electric Lift (Screw Jack) .....	7
	O. U-Wrap Lounger Seating .....	8
	P. Cockpit Aft Fill-In Backrest (Door) .....	9
	Q. Aft Walk-Thru Center Fill-In Cushion .....	9

	R.	Sun Lounge Cushions / Sunpad .....	9
	S.	Center Cockpit Cushion .....	13
	T.	C-Wrap Aft Lounger Seating .....	13
	U.	Port Lounger - Settee .....	13
N - 2		EXTERIOR UPHOLSTERY CARE .....	13
	A.	Cleaning Vinyl .....	13
	B.	Exterior Carpets .....	15
	C.	Cleaning and Maintenance .....	15
	D.	Stain Removal Testing .....	15
	E.	Stain Removal Procedures .....	16
N - 3		REPLACEMENT UPHOLSTERY .....	16
<b>WEATHER COVERS .....</b>			<b>1</b>
O - 1		GENERAL INFORMATION .....	1
	A.	Bimini Top .....	1
	B.	Camper Canvas .....	2
	C.	Full Canvas .....	2
	D.	Convertible Top (Suntop) .....	3
	E.	Side Curtains .....	3
	F.	Aft Curtains .....	3
	G.	Forward Cover .....	4
	H.	Cockpit Cover .....	4
	I.	Mooring Cover .....	4
O - 2		TRAILERING .....	5
O - 3		WINTER STORAGE .....	5
O - 4		USE OF WEATHER COVERS AND CARBON MONOXIDE .....	5
O - 5		MAINTENANCE .....	6
<b>FIBERGLASS AND HULL INFORMATION .....</b>			<b>1</b>
P - 1		HULL DESIGN INFORMATION .....	1
P - 2		FIBERGLASS CONSTRUCTION .....	1
P - 3		EQUIPMENT INSTALLATION .....	1
P - 4		FIBERGLASS CARE & MAINTENANCE .....	2
	A.	General Maintenance .....	2
	B.	Weathering Effects on Gel Coat .....	2
	C.	Stains .....	3
P - 5		FIBERGLASS REPAIRS .....	3
	A.	Scratches .....	4
	B.	Gouges & Cracks .....	4
	C.	Osmotic Blistering .....	5
P - 6		ANTIFOULING PAINT .....	5
P - 7		HULL SUPPORT .....	5
<b>WOODWORK AND COMPOSITES .....</b>			<b>1</b>
Q - 1		HIGH-PRESSURE LAMINATE CARE .....	1
Q - 2		STAR BOARD .....	1
Q - 3		BURLWOOD MAHOGANY ENHANCEMENTS .....	1
Q - 4		LAMINATED FIBERGLASS .....	1
Q - 5		CORIAN® MATERIAL .....	2
Q - 6		ACRYLIC PLASTIC - (PLEXIGLASS) .....	2



<b>GENERAL MAINTENANCE .....</b>	<b>1</b>
R - 1    WINTERIZATION .....	1
A.    Prior to Lifting for Winter Lay-up .....	1
B.    After Lifting .....	1
C.    Prior to Winter Storage .....	2
R - 2    ENGINE FLUSH OUT .....	2
R - 3    GENERAL MAINTENANCE SCHEDULE .....	3-5
<b>TRAILER INFORMATION .....</b>	<b>1</b>
S - 1    GENERAL TRAILER INFORMATION .....	1
A.    Regulations .....	1
B.    Load Carrying Capacity .....	1
C.    Hitches .....	2
S - 2    TRAILER COMPONENTS .....	2
A.    Bunk Supports .....	2
B.    Tongue .....	2
C.    Swivel Jack .....	4
D.    Coupling Assembly .....	5
E.    Surge Disc Brakes .....	5
F.    Winch .....	6
G.    Tires & Wheels .....	6
H.    Spare Tire Carrier .....	7
I.    Lights .....	7
J.    Tie-downs .....	8
S - 3    OPERATION .....	9
A.    Hitching Trailers .....	9
B.    Backing Up With Surge Disc Brakes .....	10
S - 4    TRAILERING .....	11
A.    Checklist .....	11
B.    Tactics .....	11
S - 5    MAINTENANCE .....	12
A.    Care of Exterior Finish .....	12
B.    Bunks .....	12
C.    Swivel Jack .....	12
D.    Brake Actuator & Coupling Assembly .....	12
E.    Winch .....	12
F.    Lights .....	12
G.    Tie-downs .....	12
H.    Wheels .....	13
I.    Brakes .....	13
J.    Bearings .....	13
S - 6    AXLE INSPECTION & REPAIRS .....	13
A.    Removal of Hub .....	13
B.    Bearing/Seal Inspection and Replacement .....	14
C.    Hub Reinstallation .....	14

<b>PRELAUNCH AND UNDERWAY .....</b>	<b>1</b>
T - 1 <b>LAUNCH AND CRUISE CHECKLIST .....</b>	<b>1</b>
T - 2 <b>FUELING .....</b>	<b>2</b>
A.    Recommendations .....	2
B.    Preliminary Guidelines .....	2
C.    Pumping Fuel .....	2
D.    After Fueling .....	2
T - 3 <b>LOADING PASSENGERS AND GEAR .....</b>	<b>3</b>
T - 4 <b>STARTING PROCEDURES .....</b>	<b>4</b>
A.    Preliminary Checks .....	4
B.    Starting .....	4
T - 5 <b>MANEUVERING .....</b>	<b>4</b>
A.    Leaving the Dock .....	5
B.    Stopping .....	5
T - 6 <b>ACCELERATION .....</b>	<b>5</b>
T - 7 <b>TRIMMING YOUR BOAT .....</b>	<b>6</b>
B.    Trim Tabs .....	6
B.    Tilt/Trim Control Switches .....	7
T - 8 <b>NAVIGATION LIGHTS .....</b>	<b>8</b>
T - 9 <b>HAZARDOUS CONDITIONS .....</b>	<b>8</b>
A.    Storms .....	8
B.    Fog .....	8
C.    Running Aground .....	9
D.    Warning Markers .....	9
T - 10 <b>REACTING TO EMERGENCIES .....</b>	<b>9</b>
A.    Flooding .....	9
B.    Capsizing and Man Overboard .....	9
C.    Capsizing .....	10
D.    Man Overboard .....	10
E.    Collision .....	10
F.    Fire .....	10
G.    Medical Emergency .....	11
H.    Propulsion Failure .....	11
I.    Control Failure .....	11
J.    Steering Failure .....	11
K.    Additional Underway Information .....	11
T - 11 <b>RETURNING TO SHORE .....</b>	<b>11</b>
A.    Docking .....	11
B.    Mooring .....	12
<b>GLOSSARY .....</b>	<b>1-7</b>
<b>FLOAT PLAN .....</b>	<b>1</b>
<b>FUEL LOG .....</b>	<b>1-3</b>
<b>SERVICE LOG .....</b>	<b>1-3</b>
<b>SERVICE INFORMATION .....</b>	<b>1</b>
<b>LOCATOR DRAWING .....</b>	<b>1</b>
<b>ELECTRICAL SCHEMATICS .....</b>	<b>1-57</b>

# OPERATION

## A - 1 GENERAL

Before starting the boat, become familiar with all of the various systems and related operations. Be sure all necessary safety equipment is on-board. Know the “Rules of the Road”. Have an experienced operator brief you on the general operation of your new boat. Perform a “Pre-Cruise Systems Check”. This manual is a part of your boat’s equipment. Always keep it on board.

## A - 2 COMPONENT SYSTEMS

Before you can really enjoy your boat, a thorough understanding of its systems and their operation is essential. This manual and the associated manufacturers information are included in the owner’s packet. This information is provided to enhance your knowledge of the boat. Read this information carefully.

After becoming familiar with the boat and its systems, reread this manual and other material provided in the owner’s packet. Maintenance and service tips are included to help keep the boat in like-new condition.

## A - 3 SAFETY EQUIPMENT

Besides the equipment installed on the boat by Four Winns, certain other equipment is required for passenger safety. A booklet listing the Federal equipment requirements is included in the owner’s packet or is available through your local U.S. Coast Guard Station. Remember that these laws are for your protection and are minimum requirements. Check your local and state regulations, also. More information on safety equipment is provided in Section B.

Items like a sea anchor, working anchor, extra dock lines, flare pistol, a line permanently secured to your ring buoy, etc. could at some time save your passengers lives, or save your boat from damage.

The Coast Guard Auxiliary offers a “Courtesy Examination.” This inspection will confirm the boat is equipped with all of the necessary safety equipment.

## A - 4 PASSENGER SAFETY

You are responsible for the safety of your passengers as well as for their behavior while aboard. Make sure:

1. Each passenger is properly instructed in Personal Flotation Device (PFD) use and keeps one within reach in case of emergency. All non-swimmers and children should wear a PFD at all times when underway.
2. Passengers do not sit on gunwales, open decks, elevated pedestal seats or on seat backs when the boat is underway. This could cause them to be thrown overboard during a sudden maneuver.
3. At least one other person knows how to operate the boat in case of an emergency.

## A - 5 “RULES OF THE ROAD”

As in driving an automobile, there are a few rules that must be known if safe boating operation is to be maintained. The Coast Guard, Coast Guard Auxiliary, Department of Natural Resources or your local boat club sponsor courses in boat handling, including “rules of the road”. Such courses are strongly recommended. Books on this subject are also available from local libraries.

## A - 6 LIGHTNING

When boating, it is important to be aware of the weather around you. When the weather changes for the worse, DO NOT jeopardize your safety by trying to “ride out the storm”. If possible, return to safe harbor and dock your vessel immediately.

If caught in a storm, seek shelter inside the cabin and wait for the storm to pass. With open bow models, suntops and campers will provide some protection, but should not be relied on if you are able to return to shore. Exercise care when high winds are present!



**WARNING**

DO NOT swim or dangle legs or arms into the water during a lightning storm. Stay out of the water!

Lightning will seek a ground when it strikes. Avoid contact with metal parts such as bow rails, control handle, or windshield.

**A - 7 DRUGS AND ALCOHOL**

Please keep in mind that along with the fun of boating comes responsibility. As the owner or operator of a pleasure boat, you are obligated (morally and legally) to use good judgement while underway in providing for the safety and well-being of your passengers and other boaters around you.

A common and flagrant violation of good judgement and the law by mariners involves the use of alcohol or drugs. Each year, about half of all accidents involving fatalities involve the use of alcohol or drugs.

It is a federal offense to operate a boat while intoxicated. Criminal penalties may include the termination of operating privileges for up to one year. Many states have passed similar laws.

Alcohol or drugs have an inhibiting effect on the judgement and reaction time of the boat operator and his/her passengers. Heed the advice of experts and statisticians...DO NOT drink or use drugs when operating a boat. NEVER allow an obviously intoxicated person to take the helm.

Have fun in your Four Winns® boat but also, have the good sense to be mentally alert and physically capable of operating the boat in a safe manner.

**A - 8 PRE-CRUISE SYSTEM CHECK**

Before leaving the dock, the following items should be checked:

**A. Before Starting The Engine**

1. Check the weather forecast. Determine if the cruise planned can be made safely.

2. Be sure all necessary safety equipment is on board and operative. This includes items such as the running lights, horn, spotlight, life saving devices, etc.
3. Check the bilge water level and bilge pump operation. Check the engine and drive fluid levels. Look for other signs of potential problems. Check for the scent of fuel fumes.
4. Activate the Bilge Blower. Check the blower output.



**WARNING**

Gasoline vapors can explode resulting in injury or death. Before starting the engine, check engine compartment bilge for gasoline or vapors. Operate blower for four minutes, and verify blower operation. ALWAYS run the blower when the vessel is operating below cruising speed.

5. Ensure an adequate amount of fuel is on board.
6. Be sure you have sufficient water and other provisions on board for the cruise planned.
7. Leave a written message listing details of the planned cruise with a close friend ashore.

**B. After Starting The Engine**

1. Visibly check the engine to be sure there are no apparent water or oil leaks.
2. Check the gauges. Make sure the oil pressure, water temperature, voltmeter, etc. are reading normally.
3. Have a safe cruise and enjoy yourself.

**A - 9 ENGINE OPERATIONAL PROCEDURES**

Notice: Consult engine manual. Additional engine information is located in Section T.

**A. Before Starting**

1. Check the engine compartment for water, gas, and/or oil leaks of any kind. Keep the bilge in a clean condition to prevent blower and bilge pump damage, and fire hazards.
2. Check the fluid levels of the engine oil and power steering system daily. Fill oil or steering fluid as required by the indications on the dip sticks. Refer to Table 1:

“SAE Viscosity Chart” and your engine manual included in the owner’s packet. DO NOT USE MULTI-GRADE OIL. Power steering and power trim use automatic transmission fluid. Check the fluid levels in the vertical drive units or transmission as often as practical.

IF THE LOWEST ANTICIPATED TEMPERATURE IS*	THE FOLLOWING SAE VISCOSITY OILS ARE RECOMMENDED
32° F (0° C) and above	SAE 30
0° F (-18° C) to 32° F (0° C)	SAE 20W-20
Below 0° F (-18° C)	SAE 10W
*Temperature range you expect to operate. <b>Note: Use only single viscosity oils.</b>	

Table 1: SAE Viscosity Chart

3. Start and operate the bilge blower system for at least four (4) minutes before start-up.
4. Lower the vertical outdrive units (on applicable models) making sure the water intakes are under the water.

**B. Cold Engine Start (Carbureted Engines)**

1. The engine may require priming prior to starting. To prime the engine, proceed as follows:
  - a. Place ignition switch in the OFF position.
  - b. Disengage shift mechanism.
  - c. Move control handle to the full throttle position; this operates accelerator pump and primes the engine.
  - d. Repeat priming, if necessary.
  - e. Return the control handle to fast idle position.
2. Turn key switch to START position and hold until engine starts. DO NOT hold in START position for more than ten seconds. In colder weather, more priming may be necessary. However, too much priming may flood engine.

**If engine floods:**

- Disengage shift. Move handle to full throttle position.
- Turn key switch to the START position.
- Immediately move the control handle to the idle position when the engine starts.

**NOTICE**

Failure to move the control handle to the idle position immediately when engine starts will allow engine to “over-rev” and engine damage could result. “Over-revving” engine after off-season storage could also damage the water pump impeller. **When starting engine for the first time after off-season storage, always idle engine for one minute to allow the water pump to prime.**

3. As soon as engine starts:
  - a. Release key to the ON or RUN position.
  - b. Move control handle to the fast idle position to warm up engine. DO NOT exceed 1000 RPM.

**C. Warm Engine Starting (Carbureted Engines)**

1. Move control handle to the neutral detent position.
2. Turn key switch to START position and hold until engine starts, but DO NOT hold in start position for more than ten seconds. If engine does not start, let go momentarily, then try again.
3. As soon as engine starts, release key to the ON or RUN position.

**NOTICE**

NEVER turn key to START position when engine is running.

**D. Cold / Warm Engine Start (EFI Engines)**

1. Move the control handle to NEUTRAL detent position.
2. Turn the key switch to start and hold until engine starts, for no longer than 10 seconds. If engine does not start, let go momentarily, then try again.
3. As soon as engine starts, release key to ON or RUN.

**If engine floods:**

- Disengage shift. Move handle to full throttle position.
- Turn key switch to the START position.
- Immediately move the throttle levers to the idle position when the engine starts.

**NOTICE**

Failure to move the throttle handle to the idle position immediately when engine starts will allow engine to “over-rev” and engine damage could result. “Over-revving” engine after off-season storage could also damage the water pump impeller. **When starting engine for the first time after off-season storage, always idle engine for one minute to allow the water pump to prime.**

3. As soon as engine starts:
  - a. Release key to the ON or RUN position.

**NOTICE**

Priming is not necessary for EFI engines. Refer to the engine owner’s manual for additional information.

**E. Shifting and Control Speed**

1. Move control handle to the neutral detent (idle) position. This will engage neutral start switch and allow engine to start.

 **CAUTION**

DO NOT shift into FORWARD or REVERSE unless engine is running. Damage to the shift system could result from trying to shift without the engine running. Carefully check function of all control and engine systems before leaving the dock.

2. To go FORWARD - actuate the neutral lock mechanism and briskly move the shift handle forward. Throttle movement will begin after forward gear engagement.
3. To go in REVERSE - actuate the neutral lock mechanism and briskly move the shift handle rearward. Throttle movement will begin after reverse gear engagement.

 **WARNING**

DO NOT shift from forward to reverse when the boat is planing.

**NOTICE**

DO NOT shift if engine speed is above 800 RPM.

4. To go from FORWARD to REVERSE, or REVERSE to FORWARD; always pause at NEUTRAL and allow engine speed to return to idle.
5. After shifting is completed, continue to move the control handle slowly in the desired direction to increase speed.

 **WARNING**

Any time the boat is operated, be aware of changes in shift system operation. A sudden increase in shift effort at the remote control handle, or other abnormal operation, indicates a possible problem in the shift system. If this occurs, the following precautions must be taken:

- With engine running and boat securely tied to the dock, shift drive into forward and reverse to ensure there is gear engagement.
- When docking the boat, all docking maneuvers must be performed at slow speed. Pay special attention to other boaters. Passengers should be informed of potential problems and precautions taken.

If you suspect there is a problem, see your Volvo Penta/Mercruiser dealer as soon as possible for proper diagnosis and required service or adjustment. Continued operation could result in damage to the shift mechanism and loss of control.

**F. Stopping Engine**

1. Move control handle to the NEUTRAL position.
2. Turn ignition key to the OFF position.

**NOTICE**

DO NOT stop engine at speeds above idle or “speed up” engine while turning off ignition. Engine damage could result.



**A - 10 GROUNDING AND TOWING**



If the boat should become disabled, or if assisting another craft that is disabled, great care must be taken. The stress applied to a boat during towing may become excessive. Excessive stress can damage the structure of the boat and create a safety hazard for those aboard.

Four Winns® boats are not designed nor intended to be used as a towing vessel. The mooring cleats on Four Winns® boats are not designed or intended to be used for towing purposes. These cleats are specifically designed as mooring cleats for securing the boat to a dock, pier, etc. DO NOT use these fittings for towing or attempting to free a grounded vessel.

Freeing a grounded vessel or towing a boat that is disabled requires specialized equipment and knowledge. Line failure and structural damage caused by improper towing have resulted in fatal injuries. Because of this, Four Winns strongly suggests that these activities be left to those who have the equipment and knowledge such as the U.S. Coast Guard, to safely accomplish the towing task.



Running aground can cause serious damage to a boat and associated underwater gear. If the boat should become grounded, distribute personal flotation devices and inspect the boat for possible damage. Thoroughly inspect the bilge area for signs of leakage. An experienced service facility should check the hull and underwater gear at the first opportunity. DO NOT continue to use the boat if the condition of the hull or underwater equipment is questionable.

If towing or being towed is absolutely necessary, use the strongest lines available, and attach them to the bow eyes or stern eyes only. Have all passengers slip on life jackets and take a seat in the cabin or other protected area.



Lines can snap or other hardware can be loosened or broken while towing. Under certain conditions, this can cause severe injury or fatality.

**A - 11 BOATING EDUCATION**

**A. Boating Courses**

Boating education classes are offered throughout the country. The United States Coast Guard Auxiliary offers free courses on different topics usually during the off-season. The most popular course is the “Boating Skills & Seamanship Course,” and information can be obtained by calling 1-800-336-BOAT.

The United States Power Squadron also offers free courses ranging from basic seamanship to celestial navigation. For information, contact your local Power Squadron, or write: U.S.P.S., P.O. Box 30423, Raleigh, NC 27622.

The Red Cross offers power boating and canoeing classes. Contact: Director of Water Safety, American National Red Cross, 17th & D Streets N.W., Washington, DC 20006.

The Canadian Power and Sail Squadron offers seamanship courses. Information can be obtained by calling 1-800-268-3579 (Canada only).

**B. Boating Manuals or Literature**

A good source of information is the U.S. Coast Guard’s home study book called “The Skipper’s Course”. This book may be purchased through: Superintendent of Documents, U.S. Government Printing Office, Washington, DC 20402, Stock # 050-012-00159-6.

Another good source of boating information is Chapman’s “Piloting, Seamanship and Small Boat Handling”. Also, check the local library or bookstore for additional information on boating.

**C. Charts and Maps**

U.S. nautical charts are sold throughout the country at Governmental Printing Office stores and other agents. A chart catalog is available by writing to: National Oceanic and Atmospheric Administration, National Ocean Survey, Rockville, MD 20852.

In addition, many federal agencies publish recreational maps, including the U.S. Army Corp of Engineers, the Forest Service, the National Park Service, and the Tennessee Valley Authority.

Addresses of all state boating agencies are listed in "A Boater's Guide". For a free copy, write to: National Marine Manufacturers Association, 401 N. Michigan Avenue, Chicago, IL 60611.

**D. Laws and Regulations**

The U.S. Coast Guard is the authority of the waterways; they are there to help the boating public. State boating regulations are enforced by local authorities. You are subject to marine traffic laws and "Rules of the Road" for both federal and state waterways; you must stop if signaled to do so by enforcement officers, and permit to be boarded if asked.

There are many pamphlets, prepared by the Coast Guard, available to you. These pamphlets explain "Rules of the Road," signal lights, buoys, safety, international and inland regulations and other information which goes beyond the scope of this manual. For more information contact your local U.S. Coast Guard Unit or call the Coast Guard Boating Safety Hotline at 1-800-368-5647.

**A - 12 BOAT OWNER REGISTRATION**

Federal and state laws require that every boat equipped with propulsion machinery of any type must be registered in the primary state of usage. Registration numbers and validation stickers must be displayed on the boat according to regulations. In most states, this means registration with the designated state agency. In a few jurisdictions, the Coast Guard retains registration authority. Your dealer will either supply registration forms or tell you where they may be obtained. The registration agency will issue you a certificate that must be carried on board when the boat is in use. Some states require additional registration when an out of state boat is used within their boundaries.

Your boat has a hull identification number on the starboard side of the hull. Figure A1 shows a typical identification number. Use this hull identification number for registration and to identify your boat for warranty service.

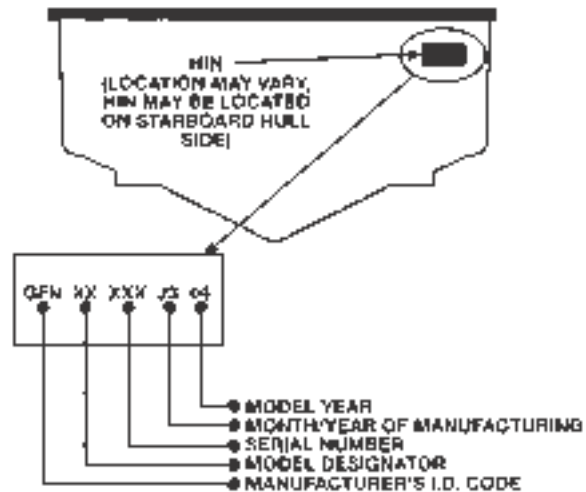

Figure A1: HIN

**A - 13 INSURANCE**

In most states, the boat owner is legally responsible for damages or injuries he or she causes, even if someone else is operating the boat at the time of the accident. Common sense dictates that you carry adequate personal liability and property damage insurance on your boat, just as you would on an automobile. You should also protect your investment by insuring your boat against physical damage or theft.

**A - 14 ACCIDENT REPORTING**

The operator of the boat is responsible for filing a report with the appropriate authorities. In general, reports are necessary for accidents involving loss of life, injury, or damage over \$500. In the case of accidents with reportable injuries or death, a formal report is required within 48 hours. If only property damage is involved, a report must be made within ten days. The 1971 Boating Safety Act may impose a \$1,000 civil fine for people who fail to submit a boating accident report. Ask your insurance agent for more information.

If you see a distress signal, you must assume it is a real emergency and render assistance immediately. The master or person in charge of a boat is obligated by law to provide assistance to any individual in danger at sea. However, you should not put your boat or crew in a dangerous

situation which exceeds your capabilities or those of your boat. The 1971 Boating Safety Act grants protection to a Good Samaritan boater offering good faith assistance, and absolves a boater from any civil liability arising from assistance given.

### A - 15 DISCHARGE OF OIL

The Federal Water Pollution Control Act prohibits the discharge of oil waste into or upon the navigable waters of the United States or the waters of the contiguous zone if such discharge causes a film or sheen upon or a discoloration of the surface of the water or causes a sludge or emulsion beneath the surface of the water. Violators are subject to a penalty of \$5,000.

### A - 16 DISPOSAL OF PLASTICS & OTHER GARBAGE

Plastic refuse dumped in the water can kill fish and marine wildlife and can foul boat propellers and cooling water intakes. Other forms of waterborne garbage can litter our beaches and make people sick. U.S. Coast Guard and most state regulations prohibit the dumping of plastic refuse or other garbage mixed with plastic into the water anywhere, and restrict the dumping of other forms of garbage within specified distances from shore.

### A - 17 MARPOL TREATY

Boats 26 feet or longer must display a sign stating the disposal regulations of the Federal Water Pollution Control Act. The U.S. Coast Guard has issued these regulations to implement Annex V of the International Convention for the Prevention of Pollution from Ships, 1973, commonly known as Annex V of the MARPOL (Marine Pollution) Treaty 73/78. They apply to all U.S. boats wherever they operate (except waters under the exclusive jurisdiction of a State) and foreign boats operating in U.S. waters out to and including the Exclusive Economic Zone (200 miles). It is important to know these regulations and adhere to them.

The regulations require U.S. recreational boaters, if your boat is 26 feet or more in length, to affix one or more USCG Trash Dumping Restrictions placards to your boat. The placard warns against the discharge of plastic and other forms of garbage within the navigable waters of the United States and specify discharge restrictions beyond the territorial sea. (The territorial sea generally ends three nautical miles from the seashore.) In addition, the plac-

ard must contain the warning that a person who violates these requirements is liable to civil (\$25,000) and criminal (Imprisonment) penalties. The placard also must note that State and local regulations may further restrict the disposal of garbage.

Operators shall display one or more placards in a prominent location and in sufficient numbers so they can be observed and read by crew and passengers. These locations might include embarkation points, food service areas, galleys, garbage handling spaces and common deck spaces frequented by crew and passengers. We recommend that these placards may be purchased from local marinas, boat dealerships and marine equipment suppliers. A special placard is available for boats operating on the Great Lakes.

**IMPORTANT:** It is illegal to discharge waste from your marine sanitary device (toilet) into the water in most areas. It is your responsibility to be aware of and adhere to all local laws concerning waste discharge. Consult with the Coast Guard, local marina or your dealer for additional information.

**NOTE:** Some states and localities have legal limits on speed, noise and trailer specifications. It is your responsibility to be aware of these laws and limits and to insure that your boat (and trailer) comply. Consult with your local Marine Patrol or local Coast Guard office.

# SAFETY & SAFETY EQUIPMENT

## B - 1 GENERAL

As the owner/operator of the boat, you are responsible for assuring that all required safety equipment is aboard. You should also consider supplying additional equipment as needed for your safety and that of your passengers. Check state and local regulations and call the U.S. Coast Guard Boating Safety Hotline at 1-800-368-5647 for information about required safety equipment.

### A. Required Safety Equipment

Most of the safety equipment required by federal regulations is provided as standard equipment. Personal Floatation Devices (life jackets) must fit the person wearing it. If local regulations require additional equipment, it must be approved by the U.S. Coast Guard (USCG). Minimum requirements include the following:

- Personal Floatation Devices
- Visual Distress Signal
- Bell or Whistle
- Fire Extinguisher
- Navigation Lights

#### NOTICE

As the owner/operator of the boat, you are responsible for assuring that all required safety equipment is aboard and meets the boating regulations as prescribed by both federal and local authorities in your area.

### B. Personal Floatation Devices (PFDs)

Federal regulations require that you have at least one Coast Guard approved personal floatation device (PFD) for each person in a recreational boat. You should not use your boat unless all PFDs are in serviceable condition, readily accessible, legibly marked with the Coast Guard approval number, of an appropriate size (within the weight range and chest size marked on the PFD) for each person aboard.

A PFD provides buoyancy to help keep your head above the water and to help you remain in a satisfactory position while in the water. Body weight and age should be considered when selecting a PFD. The buoyancy provided by the PFD should support the person's weight in the water.

The size of the PFD should be appropriate for the wearer. Body weight or chest size are common methods used to size PFDs. It is your responsibility to ensure that you have the proper number and types of PFDs on board and that your passengers know where and how to use them.

### C. PFD Types

Five types of PFDs have been approved by the U.S. Coast Guard. The PFDs are described as follows:

**PFD Type 1, Wearable** (Figure B1) has the greatest required buoyancy. Its design allows for turning most unconscious persons in the water from face down position to a vertical or slightly backward, face-up position. It can greatly increase the chances of survival. Type 1 is most effective for all waters, especially offshore when rescue may be delayed. It is also the most effective in rough waters.



*Figure B1: Type I, Wearable*

**PFD Type II, Wearable** (Figure B2) turns its wearer in the same way as Type I, but not as effectively. The Type II does not turn as many persons under the same conditions as a Type I. You may prefer to use this PFD where there is a probability of quick rescue such as in areas where other people are commonly involved in water activities.



*Figure B2: Type II, Wearable*

**PFD Type III, Wearable** (Figure B3) allows the wearer to place themselves in a vertical or slightly backward position. It does not turn the wearer. It maintains the wearer in a vertical or slightly backward position and has no tendency to turn the wearer face down. It has the same buoyancy as a Type II PFD and may be appropriate in areas where other people are commonly involved in water activities.



**Figure B3: Type III, Wearable**

**PFD Type IV, Throwable** (Figure B4) is required in addition to the PFDs previously discussed. The most common Type IV PFD is a buoyant cushion or ring buoy. It is designed to be thrown to a person in the water, grasped and held by the user until he or she is rescued. A Type IV PFD should always be in serviceable condition and immediately available for use. Grasping this PFD may be difficult if the rescue is delayed or if the user is overcome by hypothermia (loss of body heat).



**Figure B4: Type IV, Throwable**

**PFD Type V, Wearable** (Figure B5) when inflated, it provides buoyancy equivalent to Type I, II, or III PFDs. When it is deflated, however, it may not support some people.



**Figure B5: Type V, Wearable**

#### D. PFD Pointers

The purpose of a PFD is to help save your life. If you want it to support you when you are in the water, it needs to fit, float, and be in good condition.

1. Try the PFD on and adjust it until it fits comfortably in and out of the water. Mark your PFD if you are the only wearer.
2. To make sure the PFD works, wear it in the water. This will show you how it works and give you confidence when you use it.
3. Teach children how to put a PFD on and allow them to try it in the water. That way, they know what the PFD is for and how it works. They will feel more comfortable with it if they suddenly find themselves in the water.
4. If the PFD is wet, allow it to dry thoroughly before storing it. Do not dry it in front of a radiator or heater. Store it in a well ventilated area.
5. Keep PFDs away from sharp objects which can tear the fabric or puncture the floatation pads.
6. For their own safety and the safety of others, all nonswimmers, poor swimmers, and small children should wear PFD's at all times, whether the boat is stationary or moving.
7. Check the PFD frequently to make sure that it is not torn, that floatation pads have no leaks, and that all seams and joints are securely sewn.
8. If a PFD contains kapok, the kapok fibers may become waterlogged and lose their buoyancy after the vinyl inserts are punctured. If the kapok becomes hard or if it is soaked with water, replace it. It may not work when you need it.

#### E. Fire Extinguisher

As the owner/operator of the boat, you are responsible for supplying a fire extinguisher approved by the U.S. Coast Guard.

Hand-held portable extinguisher(s) should be mounted in a readily accessible location(s) away from the engine compartment. All persons aboard should know the location(s) and proper operation of the fire extinguisher(s).





**Fire!**

In case of fire do not open the engine compartment. Shut down engine(s), generator(s), and blower(s). Models with fixed fire suppression system will automatically discharge its entire contents. If using portable CO2 fire extinguisher continuously discharge entire contents. On European models, discharge contents through fire port.

**NOTICE**

Using a portable fire extinguisher with an access/fire port in the engine compartment is preferred to opening the engine compartment to fight the fire. However, using a portable extinguisher in this way provides less protection against fire than a fixed suppression system.

**NOTICE**

Do not test fire extinguishers by squirting small amounts of the extinguishing compound. The fire extinguisher might not work when you really need it.

The Freedom™ and Horizon™ models that measure 16 to less than 26 feet are considered Class 1 powerboats. Since they have permanently installed fuel tanks, they are required to carry one (1) B-1 type hand portable fire extinguisher. If the boat is equipped with a fixed fire extinguishing system in the engine compartment, one (1) B-1 type hand portable fire extinguisher is still recommended.

Horizon™ models that are Class 2 powerboats (26 to less than 40 feet) are required to carry two (2) B-1 type approved hand portable fire extinguishers or one (1) B-2 type approved hand portable fire extinguisher. When a fixed fire extinguishing system is installed in machinery space(s), at least one (1) B-1 type approved hand portable fire extinguisher is recommended.

**F. Fire Extinguisher System**

An automatic FE241 agent fire extinguisher system is optional on certain models. The equipment utilized has been so chosen, and located, to provide sufficient volume and coverage of the entire engine compartment. While the system ensures excellent overall bilge fire protection, **it does not eliminate the U.S.C.G. requirement for hand-held fire extinguishers.** Refer to the manufacturer's literature included in the owner's packet.

**G. Visual Distress Signal Devices**

Visual distress signal devices approved by the U.S. Coast Guard are required on all recreational boats operating on coastal waters and to boats owned in the United States when they are operating on the high seas. Coastal waters include territorial seas and those waters directly connected to the Great Lakes and the territorial seas up to a point where the waters are less than two miles (3.2km) wide. Visual distress signal equipment may be of the pyrotechnic or non-pyrotechnic type. Regulations prohibit display of visual distress signals on the water under any circumstances except when assistance is required to prevent immediate or potential danger to persons on board a vessel.

The equipment must be approved by the U.S. Coast Guard, be in serviceable condition, and be stowed in a readily accessible location. Equipment having a date for serviceable life must be within the specified usage date shown. Careful selection and proper stowage of visual distress equipment is very important if young children are aboard.

DAY USE ONLY	NIGHT USE ONLY	DAY AND NIGHT USE
Three orange smoke signals (one hand held and two floating) or one orange flag with black square and disk.	One S-O-S electric distress light.	Three flares of the hand held, meteor or parachute type.

*Distress Signal Table*

The minimum visual distress signals required in coastal waters for a Class 1 or Class 2 powerboat is the following:

One orange flag with black square-and disc (daytime); and an S-O-S electric light (nighttime); or three orange smoke signals, hand held or floating (daytime); or three red flares of hand held, meteor, or parachute type (daytime/night-time).

**NOTICE**

No single signaling device is appropriate for all purposes. Consider keeping various types of equipment on board.



**H. Sound Signaling Devices**

Class 1 and Class 2 powerboats are required to carry a hand, mouth or power operated horn or whistle. It must produce a blast of two-second duration and audible at a distance of at least one-half (1/2) mile.

The following are standard whistle signals:

- One Prolonged Blast    Warning Signal
- One Short Blast        Pass on my Port Side
- Two Short Blasts        Pass on my Starboard Side
- Three Short Blasts      Engines in Reverse
- Five or More Blasts    Danger Signal

**I. Navigation Lights**

Navigation lights are intended to keep other vessels informed of your presence and course. If you are out on the water between sunset and sunrise, you are required to display appropriate navigation lights.

**J. Additional Recommended Equipment**

Four Winns recommends that you acquire additional equipment for safe, enjoyable cruising. This list, which is not all inclusive, includes items you should consider acquiring.

**Basic Gear**

- |                                              |                     |               |
|----------------------------------------------|---------------------|---------------|
| Flashlight                                   | Spare batteries     | Tow line      |
| Oar, paddle                                  | Mooring lines       | Compass       |
| Dock fenders                                 | Distress signals    | First aid kit |
| Boat hook                                    | VHF radio           | EPIRB*        |
| Sunscreen                                    | Extra warm clothing | Charts        |
| Second anchor & line                         |                     |               |
| Dewatering device (pump or bailer)           |                     |               |
| Emergency supply of drinking water and food. |                     |               |
| *Emergency Position Indicating Radio Beacon  |                     |               |

**Tools**

- |                   |                 |                 |
|-------------------|-----------------|-----------------|
| Spark plug wrench | Hammer          | Screwdriver     |
| Jackknife         | Pliers          | Electrical tape |
| Adjustable wrench | Lubricating oil | Prop wrench     |
| Duct tape         |                 |                 |

**Spare Parts**

- |                       |             |             |
|-----------------------|-------------|-------------|
| Extra bulbs           | Spare prop  | Extra fuses |
| Extra drain plug      | Spark plugs | Spare wire  |
| Extra prop nut/washer |             |             |

**Gear For Extended Cruises**

- |                                                         |                 |          |
|---------------------------------------------------------|-----------------|----------|
| Foul weather gear                                       | Parallel rulers | Dividers |
| Loran or Global Positioning System navigation equipment |                 |          |

**B - 2 CARBON MONOXIDE**



**Carbon Monoxide!**

Carbon monoxide (CO) can be harmful or fatal if inhaled. Brain damage or death can result from prolonged exposure to carbon monoxide. Keep exhaust outlets clear of blockage. Provide adequate ventilation. Open hatches, doors, windows and vents to insure adequate ventilation. Close engine compartment doors and hatches when engine or generator is running. Avoid operating the boat for extended periods of time at idle speed, and be sensitive to weather conditions that may prevent CO from dissipating into the air. Do not stand or swim near engine or generator exhausts when engines are running.

Carbon monoxide accumulation is affected by many variables (e.g., boat geometry, hatch, window and door opening, ventilation openings, proximity to other structures, swim platforms, canvas enclosures, location of exhaust outlets, vessel attitude, wind direction, vessel speed, boat systems maintenance, etc.) The technical information included in this section is to inform the boat owner of possible cause and effects of carbon monoxide exposure. This information has been reprinted with permission from the American Boat and Yacht Council's (ABYC) technical information report: "[Educational Information About Carbon Monoxide](#)". This information pertains to all gasoline powered boats manufactured by Four Winns.

**NOTICE**

The boat owner should be aware that other factors may contribute to carbon monoxide accumulation. The most common ones are listed in this section. If a person is exhibiting carbon monoxide-type symptoms (Refer to B-2E Symptoms), be sure to take the necessary precautions as prescribed later in this section.

**A. Properties and Characteristics of Carbon Monoxide**

1. Carbon monoxide is a colorless, odorless and tasteless gas. It is commonly referred to as CO.
2. Its weight is about the same as air so it cannot be expected to rise or fall like some other gases, but will distribute itself throughout the space.

**NOTICE**

DO NOT rely on the use of smell or sight of other gases to detect CO, because it diffuses in the air much more rapidly than easily detectable vapors (i.e. visible and aromatic vapors).

**B. What Makes Carbon Monoxide**

Any time a material containing carbon burns such as gasoline, natural gas, oil, propane, coal, or wood, CO is produced.

Common sources of carbon monoxide are:

1. Internal combustion engines.
2. Open flame devices such as:
  - a. Cooking ranges
  - b. Central heating plants
  - c. Space heaters
  - d. Water heaters
  - e. Fireplaces
  - f. Charcoal grills

**C. How a Person is Affected by Carbon Monoxide**

Carbon monoxide is absorbed by the lungs and reacts with blood hemoglobin to form carboxyhemoglobin, which reduces the oxygen carrying capacity of the blood. The result is a lack of oxygen for the tissues with the subsequent tissue death and, **if exposure is prolonged, death of the individual.**

**D. Effects of Carbon Monoxide**

Carbon monoxide in high concentrations can be fatal in a matter of minutes. Lower concentrations must not be ignored because the effects of exposure to CO are cumulative and can be just as lethal.

Certain health related problems and age will increase the effects of CO. People who smoke or are exposed to high concentrations of cigarette smoke, consume alcohol or have lung disorders or heart problems, are particularly susceptible to an increase in the effects from CO. However, all occupants' health should be considered. Physical exertion accelerates the rate at which the blood absorbs CO.

**E. Symptoms**

One or more of the following symptoms can signal the adverse effect of CO accumulation:

1. Watering and itchy eyes
2. Flushed appearance
3. Throbbing temples
4. Inattentiveness
5. Inability to think coherently
6. Loss of physical coordination
7. Ringing in the ears
8. Tightness across the chest
9. Headache
10. Drowsiness
11. Incoherence
12. Slurred speech
13. Nausea
14. Dizziness
15. Fatigue
16. Vomiting
17. Collapse
18. Convulsions

**NOTICE**

The order of the above list is generally the sequence of appearance of symptoms. However, the order of appearance may change for different people.

**NOTICE**

**The symptoms of carbon monoxide poisoning may easily be mistaken for seasickness.**

**F. Treatment (Evaluate, Ventilate, Evacuate, Investigate, Take Corrective Action)**

1. Evaluate the situation and ventilate the area if possible.
2. Evacuate the area and move affected person(s) to a fresh air environment.
3. Observe the victim(s).
4. Administer oxygen if available.
5. Contact medical help. If the victim is not breathing, perform rescue breathing or approved cardiopulmonary resuscitation (CPR), as appropriate, until medical help arrives and takes over.

**NOTICE**

Prompt action can make the difference between life and death.

- Investigate source of CO and take corrective action.

**G. Inspection**

Look and listen for leaks in the exhaust systems of both the generator and propulsion engine(s). Look for discoloration around joints in the system (water leaks, carbon, stains, etc.).

- Make sure all exhaust clamps are in place and secured.
- Make sure ventilation systems work and are not obstructed or restricted.
- Make sure gaps around the engine room plumbing and cableways and exhaust system doors, hatches, and access panels are minimized to reduce the opportunity for CO to enter the accommodation space(s).

**H. Operation**

Cold Start vs. Warm Start: CO production is greater while the combustion chamber surfaces and gas passages are cold versus when they are warm. A boat operator should:

- Pay attention to ventilating the boat.
- Orient the boat so it will allow the maximum dissipation of CO.
- Minimize the time spent on getting underway.
- In order to minimize CO buildup, do not warm up or run propulsion engine(s) for extended periods while the vessel is stationary.



**WARNING**

The following are examples of possible situations where carbon monoxide can accumulate within your boat while docked, anchored, or underway. Become familiar with these examples and their precautions to prevent **dangerous** accidents or death.

**I. Boathouses, Sea Walls and Confined Spaces**

A boat operator should be aware that dangerous concentrations of CO can accumulate when a boat, generator or other engine operated device is operated while the boat is moored in a confined area such as:

- Boathouses,
- Proximity to sea walls, or
- Proximity to other boats.

Keep engine room hatches and doors closed when operating engines, including the generator.

Pay attention to prevailing conditions and provide for ventilation to induce fresh air and minimize exhaust re-entry. Orient the boat for maximum dissipation of the exhaust. **DO NOT** run the boat or boat equipment for extended periods under these conditions. See Figure B6.



*Figure B6: The effect of sea walls and other confined spaces.*

Be aware that cockpit and deck drains can be a source of CO ingress into boats, especially boats with cockpit or decks enclosed with canvas or permanent boat structures.

**J. The Effect of Boats Moored Along Side**

A boat operator should be aware that carbon monoxide is emitted from any boat's exhaust. The operation, mooring, and anchoring in an area containing other boats may be in an atmosphere containing CO not of the operator's making. An operator likewise needs to be aware of the effect of their boat on other boats in the area. Of prime concern is the operation of an auxiliary generator where boats are moored along side each other. Be aware of the effect your exhaust may have on other boats and be aware that the operation of other boats' equipment may affect the carbon monoxide concentration on your boat. See Figure B7.



Figure B7: The effect of boats moored along side.

**K. Backdrafting (Station Wagon Effect)**

Backdrafting or the “station wagon effect” is caused by air movement over or around a boat creating a low pressure area or suction area around the stern that can increase CO level on the boat. Backdrafting can be affected by relative wind direction, boat speed, and boat trim angle. See Figure B8 Backdrafting - Airflows Over Boat and Behind Transom”.

Under certain speed and operating conditions the low pressure area may form in other regions and permit carbon monoxide to enter the hull through openings that are not on the back of the boat. Boat factors which may affect CO concentration:



Figure B8: Backdrafting - Air flows over boat and behind transom.

1. Intentional or unintentional excessive trim angle causing high bow angle. See Figure B9.
2. Excessive or unequally distributed weight.



Figure B9: Inefficient trim angles.

3. Canvas Configurations - Under various conditions, adding or removing canvas may raise or lower CO levels. See Figures B8, B9 & B11.



**WARNING**  
**Exhaust Fumes!**

Hull exhaust from your boat can cause excessive accumulation of poisonous carbon monoxide gas within cockpit areas when using protective weather coverings (while underway or while stationary). Provide adequate ventilation when the canvas top, side curtains and/or back (aft) curtains are in their closed protective positions.

4. Opening and closing ports, hatches, doors, and windows may raise or lower CO levels on board a boat. When airflow is moving forward inside the boat, CO may be entering the boat. See Figures B10 and B11.

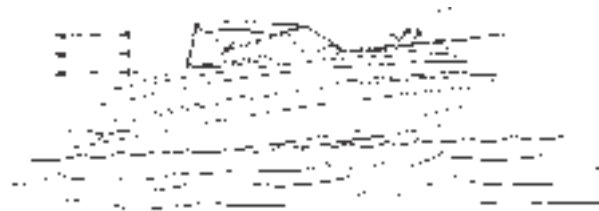

Figure B10: Desired air flow through the boat.



Figure B11: The effect of canvas configurations.

5. Operating a boat at slow speeds with a following wind should be avoided. Consider changing direction, adjusting speed, or both. See Figures B12.



Figure B12: Operating at Slow Speed with Following Wind

6. Be aware that cockpit and deck drains can be a source of CO ingress into boats, especially boats with cockpit or decks enclosed with canvas or permanent boat structures.

**L. Accumulation of Exhaust Gases-Swim Platform**

When the propulsion engine(s) or generator is running, CO is produced and may remain in the vicinity of the exhaust outlet (including underwater exhaust outlets such as sterndrives and outboards):

1. Do not occupy aft lounging area(s) or swim platform.
2. Do not swim under or around swim platform.
3. Do not swim in the vicinity of the exhaust outlet.

Refer to Figure B13.



Figure B13: Exhaust Gas Accumulation at Swim Platform

**M. Dangerous Activity - “Teak Surfing”/“Dragging”**

Do not sit on, occupy or hang on any stern appendages (e.g., swim platforms, boarding ladders, etc.) while underway. Do not body surf, commonly known as “teak surfing” or “dragging”, etc. in the wake of the boat. Do not tow persons in close proximity to the stern of the boat. See Figure B14. This activity can also increase the possibility of injury due to contact with a rotating propeller.



Figure B14: Exhaust Gas Accumulation-Dangerous Activity

**N. Cabin Appliances**

Boats having fuel burning appliances in accommodation areas should be provided with adequate ventilation and the appliance should be maintained to function properly.

**O. Ventilation of Accommodation (Occupied) Spaces**

Accommodation spaces need to be ventilated to introduce fresh air into the spaces. Ventilation methods (e.g. windows, hatches, doors, and blowers) used to accomplish this may, under certain conditions, bring hazardous levels of CO into the occupied spaces. Care should be taken to be aware of all prevailing conditions when using these ventilating methods.

**P. Running of Engines in Idle**

Engines running in idle exhaust carbon monoxide that can accumulate near the hull of the boat. Do not stand or swim near the engine exhaust or outdrive when engines are idling or generator is running.

**Q. Altitude and Sea Conditions**

Operation at altitudes greater than 5,000 feet contributes to inefficient engine performance and may require adjustments to the ignition systems, fuel systems, or changing the propeller’s size or gear ratio.

1. Failure to make adjustments to ignition systems and/or fuel systems for altitude conditions may cause an increase in CO production.
2. Reduced power resulting from increased altitude may require adjustments to propeller size.
3. Heavy sea or out of trim conditions tend to load engines resulting in reduced performance and thereby increasing their CO production.



## R. Portable Generator Sets



**DANGER**

**Never use a portable generator on a boat.**

Gasoline powered portable generators are available in the marine market place and are not an option available through Four Winns. Portable generators will produce CO. These sets discharge their exhaust products in locations which can cause accumulation of carbon monoxide in the accommodation space. **Do not use gasoline powered portable generators on Four Winns® boats.**

## S. Maintenance - Engine Performance

Efficient engine performance is vital to minimizing CO production. The following items are those considered to have the greatest effect on increased CO production:

1. Fuel Systems - Fuel that is contaminated, stale or incorrect octane number
2. Carburetors/Injectors
  - a. Dirty or clogged flame arrester
  - b. Malfunctioning automatic choke plate or faulty adjustment of manual choke plate
  - c. Worn float needle valve and seat
  - d. High float level
  - e. Incorrect idle mixture adjustment
  - f. Dirty or worn injectors
3. Ignition System
  - a. Fouled or worn spark plug.
  - b. Worn points or incorrect gap on points
  - c. Shorted or opened circuit high tension spark plug cables
  - d. Incorrect ignition timing.

## 4. General

- a. Worn piston rings and valves
- b. Engine temperature - Cold running engines increase CO production. Engine cooling water system design and selection of thermostat(s) are primary considerations affecting engine operating temperature. Generally, an engine produces less CO if it operates at a relatively high temperature within manufacturer's specifications.
- c. Exhaust Back-Pressure - Certain alterations to the exhaust system may increase engine exhaust back pressure and CO production.
- d. Restricted engine room or compartment ventilation

## T. Maintenance - External Conditions

External conditions that contribute to inefficient engine performance can include:

1. Fouled hull bottom
2. Damaged and fouled running gear (i.e., shaft, strut propeller, rudder and trim tabs)
3. Incorrect selection of propeller size

## U. Maintenance - Exhaust System Integrity

Gas tight integrity of exhaust systems must be maintained to insure that leakage of CO within the boat does not occur. Disassembly may be required to carry out a thorough inspection. Repair or replace components as indicated. Inspect the following:

1. Gaskets at cylinder head connection
2. Casting and pipe fittings in the dry section
3. All joints
4. Hoses
5. Clamps
6. Mufflers and their drain plugs
7. Thru-hull fittings
8. Hangers and other supports

## V. Maintenance - Ventilation Systems

Boats are equipped with ventilation systems to eliminate gasoline vapors. Blowers and fans may also be provided for ventilation and to mitigate the migration of CO into occupied compartments. Attention should be paid to the following:

1. Keeping ventilation intakes clear of debris
2. Replacing damaged hardware
3. Maintaining the integrity of the ducting material and its connections
4. Ensuring that position of ducting intake is not obstructed or restricted, collapsed, kinked, or crushed
5. Eliminating sags in ducting that can form a water trap
6. Checking hangers and other supports
7. Ensuring blower/fan is operational
8. Ensuring that airflow is present at discharge
9. Inspecting wiring to equipment

## W. Maintenance - Bulkhead and Deck Integrity

1. Seal all visible openings (e.g., cracks, crevices, holes, including openings around wiring and piping runs) in bulkheads and decks that separate machinery compartments from occupied compartments. These openings can permit migration of CO vapors.
2. Check gaskets and sealing surfaces on hatches, doors, and access panels.

## X. Maintenance - Liquid Drains

Sink, shower and condensate drains can be a source of CO ingress. Ensure that water traps are present and contain fluid. These traps may be in the form of a double loop in the drain line or prefabricated p-traps. Any drain that terminates below the waterline is, by virtue of its design, sealed against CO intrusion. Some drains that are below the waterline when boat is underway will be above the waterline when the boat is at rest. The location of drains, relative to the waterline, can be affected by the dynamics of boat motion (i.e., underway or at rest).

## B - 3 SAFE BOATING PRACTICES

### NOTICE

**YOU** are responsible for your own safety, the safety of your passengers, and the safety of fellow boaters.

### A. Drugs and Alcohol



**Alcohol consumption and boating do not mix! Operating under the influence endangers the lives of your passengers and other boaters. Federal laws prohibit operating a boat under the influence of alcohol or drugs.**

Do not use drugs or drink alcohol while operating a boat. Like driving a car, driving a boat requires sober, attentive care. Operating a boat while intoxicated or under the influence of drugs is not only dangerous, but it is also a Federal offense carrying a significant penalty. These laws are vigorously enforced. The use of drugs and alcohol, singly or in combination, decreases reaction time, impedes judgement, impairs vision, and inhibits your ability to operate a boat.

### B. Safe Operation

Safe operation means that you do not misuse your boat nor do you allow your passengers to do so. Safe operation means using good judgement at all times. It includes, without limitation, the following actions:

- Observe all safety signs and warnings both inside the boat and in the immediate boating area.
- Become familiar with, and adhere to, the "Rules of the Road".
- Maintain boat speed at or below the legal limits. Avoid excessive speed or speeds not appropriate for operating conditions.
- Be sure at least one other passenger is familiar with the operation and the safety aspects of the boat in case of an emergency.
- Load the boat within the limits listed on the capacity plate. Balance loads bow and stern and port to starboard.



- Do not use the boat in bad weather or sea conditions beyond the skill or experience of the operator or the comfortable capability of the boat or passengers.
- Make sure the passengers and gear do not obstruct the operator's view or impede his ability to move.
- Do not exceed the maximum engine power rating stated on the certification plate located inside the boat.

**C. Passenger Safety**

Before getting underway, show all passengers where emergency and safety equipment is stowed, and explain how to use it. Everyone aboard should wear rubber-soled shoes which resist slipping on wet surfaces. While underway, passengers should remain seated inside the deck rails and gates. Do not allow passengers to drag their feet or hands in the water. Always use handholds and other safety hardware to prevent falls. All nonswimmers, poor swimmers and small children should wear PFDs at all times.

**D. Propeller**

**WARNING**

**Personal Injury!**

Do not allow anyone near a propeller, even when the engine is off. Propeller blades can be sharp and continue to turn even after the engine is shut off. Do not allow anyone near the propeller when the throttle is in neutral position. Accidentally engaging the shift can result in a serious injury or death. (See actual ladder warning labels and helm boarding ladder warning label below.)

**DANGER**

Never approach or use ladder when motor is running. Severe injury or death will result from contact with rotating propeller.

**Ladder Warning Label**

**DANGER**

Shut off motor when near swimmers. Severe injury or death will result from contact with rotating propeller.

**Helm Boarding Ladder Warning Label**

**WARNING**

When pulling skiers do not turn on the engine until you are at least a boat length away from the person in the water. When approaching a downed skier, turn off the engine at least one boat length away before reaching the skier in the water.

**E. First Aid**

As a boater, you should be familiar with the basic first aid procedures that may be needed while you are out far from help. Fish hook accidents or minor cuts and abrasions may be the most serious mishaps on board a boat but you should also learn the proper procedures and be ready to deal with the truly serious problems like mouth-to-mouth resuscitation, excessive bleeding, hypothermia, and burns. First aid literature and courses are available through most Red Cross chapters.

**F. Operation By Minors**

Minors should always be supervised by an adult whenever operating a boat. Many states have laws regarding the minimum age and licensing requirements of minors. Be sure to check local laws or contact the state boating authorities for information.

**G. "Rules of the Road"**

As a responsible boater, you must comply with the "Rules of the Road," the marine traffic laws enforced by the U.S. Coast Guard. Navigating a boat is much the same as driving an automobile. Operating either one responsibly means complying with a set of rules intended to prevent accidents. Just as you assume other car drivers know what they are doing, other boaters assume you know what you are doing. Information regarding navigational rules and the "Rules of the Road" are discussed in further detail in C-1 & C-2 of the next section.

**H. Voluntary Inspections**

State boating officials in many states or the U.S. Coast Guard Auxiliaries offer courtesy inspections to check out your craft. They will check for compliance with safety standards and required safety equipment. You may voluntarily consent to one of these inspections, and you are allowed to make corrections without prosecution. Check with the appropriate state agency or the Coast Guard Auxiliary for details.

**I. Safe Boating Courses**

The local U.S. Coast Guard Auxiliary and the U.S. Power Squadrons offer comprehensive safe boating classes several times a year. You may contact the Boat/U.S. Foundation at 1-800-336-BOAT (2628) or, in Virginia, 1-800-245-BOAT (2628) for a course scheduled in your area. Also contact the U.S. Coast Guard Auxiliary or Power Squadron Flotilla for the time and place of their next scheduled class.

**B - 4 WATER SPORTS**



**Personal Injury!**

Four Winns® boats are not designed for and should not be used for pulling parasails, kites, gliders or any device which can become airborne. Use boat only for appropriate water sports. (See Preface for actual warning label.)

Water skiing, kneeboarding, wakeboarding or riding a towed, inflatable apparatus are some of the more popular water sports. Taking part in any water sport requires increased safety awareness by the participant and the boat operator. If you have never pulled someone behind your boat before, it is a good idea to spend some hours as an observer, working with and learning from an experienced driver. It is also important to be aware of the skill and experience of the person being pulled. Always have a second person on board to observe the person in the water so the driver can concentrate on operating the boat.

**A. Water Sport Guidelines**

Everyone participating in a water sport should observe these guidelines:

1. Allow only capable swimmers to take part in any water sport.
2. Always wear a personal floatation device (PFD) approved by the U.S. Coast Guard. Wearing a properly designed PFD helps a stunned or unconscious person stay afloat.
3. Be considerate of others you share the water with.
4. Give immediate attention to a person who has fallen. He or she is vulnerable in the water alone and may not be seen by other boaters.
5. Approach a person in the water from the lee side (opposite the direction of the wind). **Turn off the motor at least a boat length from the person.**
6. Turn engine off and anchor before swimming.
7. Always participate in water sports in safe areas. Stay away from other boats, beaches, restricted areas, swimmers and heavily traveled waterways.
8. Swim only in areas designated as safe for swimming. These are usually marked with a swim area buoy (see Figure B15). Do not swim alone or at night.



Figure B15: Swim Area Buoy



**Rotating Propeller!**

Rotating propeller can cut or sever causing serious injury or death. Shut engine off and remove ignition key when anyone is swimming nearby. (See Section B-3D.)

9. Do not allow anyone near the propeller(s), even when the engine is off. Propeller blades are sharp and can continue to turn even after the engine is off. Stay at least 150 feet away from areas marked by diver down float. See Figure B16.



Figure B16: Diver Down Float

10. Do not drive the boat directly behind a water skier. At 25 miles per hour, the boat will overtake a fallen skier who was 200 feet in front in about 5 seconds.

## B. Water Skiing

The popular sport of water skiing has brought a special set of safety precautions to observe in boating. The following guides help prevent accidents while water skiing.

1. Water ski only in safe areas, away from other boats and swimmers, out of channels, and in water free of underwater obstructions.
2. Allow no one who can not swim to water ski. Skiers must wear a USCG approved floatation device. A Type III water-ski vest is an approved and practical PFD.
3. Have a second person aboard to observe the skier and inform the driver about the skier's hand signals (Figure B17). The driver must give full attention to operating the boat and the waters ahead.
4. Give immediate attention to a fallen skier. Be careful not to swamp the boat while taking the skier on board.
5. Always participate in water sports in safe areas. Stay away from other boats, beaches, swimmers, and heavily traveled waterways.
6. Be considerate of others you share the water with.

7. Give immediate attention to a person who has fallen. He or she is vulnerable in the water alone and may not be seen by other boaters.
8. Approach a person in the water from the lee side (opposite the direction of the wind). Stop the motor at least a boat length from the person.
9. Turn off engine and anchor your boat before swimming.



**WARNING**

### Rotating Propeller!

Rotating propeller can cut or sever causing serious injury or death. Switch engine off before skiers enter the water and before taking skiers aboard. **Do not leave engine running in neutral.** Accidentally engaging shift can seriously injure skier.

10. Do not water ski between sunset and sunrise. It is illegal in most states.

For more information about water skiing, please contact the American Water Ski Association, 799 Overlook Drive, Winter Haven, FL. 33884 or call 1-800-533-2972.



**FASTER-**  
Palm of one hand pointing upward.



**SLOWER-**  
Palm pointing down.



**SPEED OK-**  
Arm upraised with thumb and index finger joined to form circle.



**RIGHT TURN-**  
Arm outstretched pointing to the right.

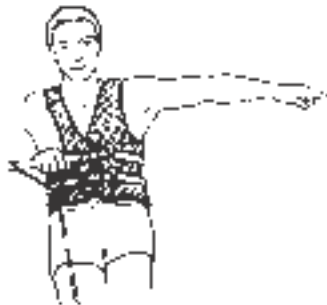

**LEFT TURN-**  
Arm outstretched pointing to the left.



**RETURN TO DROP-OFF AREA -**  
Arm at 45 degree from body pointing down to water and swinging.



**CUT MOTOR-**  
Finger drawn across throat.



**STOP-**  
Hand up, palm forward, policeman style.



**SKIER OK, AFTER THE FALL-**  
Hands clasped together overhead.



**PICK ME UP OR FALLEN SKIER, WATCH OUT-**  
One ski extended vertically out of water.

Figure B17: Skiing Signals

# BASIC SEAMANSHIP

## C - 1 GENERAL

Basic rules of seamanship, general information about navigational aids, and sources for additional reading and boater education are presented in this portion of your owner's manual.

### A. Boating Regulations

The U.S. Coast Guard is the authority of the waterways. State boating regulations are enforced by local authorities. Your boat is subject to the marine traffic laws known as "Rules of the Road," which are enforced by the U.S. Coast Guard. You are subject to marine traffic laws and "Rules of the Road" for both federal and state waterways; you must stop if signaled to do so by enforcement officers, and permit them to board if asked. The "Rules of the Road" can be obtained from the local U.S. Coast Guard Unit or the United States Coast Guard Headquarters by calling (202) 512-1800 or faxing your request to (202) 512-2250, and asking for the publication titled "Navigational Rules, International-Inland.

Many pamphlets prepared by the Coast Guard are available. They explain signal lights, buoys, safety, international and inland regulations and other information which goes beyond the scope of this manual. "Aids to Navigation" (U.S. Coast Guard pamphlet #123) explains the significance of various lights and buoys. Because of proposed alterations to buoys and markers, contact the U.S. Coast Guard to stay informed of changes. Other pamphlets, including the "Boating Safety Training Manual" and "Federal Requirements For Recreational Boats," are also available from the U.S. Coast Guard Headquarters.

#### NOTICE

The spoken word "**MAYDAY**" is the international signal for distress. "**MAYDAY**" should **NEVER** be used unless there is grave or imminent danger, and you are in need of immediate assistance.

## B. Rules of Seamanship

### 1. Right-of-way

In general, boats with less maneuverability have right-of-way over a more agile craft. You must stay out of the way of the following vessels:

A vessel not under command or aground.	These vessels have no maneuverability.
A vessel restricted in its maneuverability.	These vessel are performing work which limits their maneuverability such as surveying, dredging, laying pipe or cable, servicing navigational markers among others.
A vessel engaged in fishing.	These include boats fishing with lines, trawl or nets; but not trolling lines.
Sailboats	Sailboats have the right-of-way over power boats; however, if a sailboat is using a propeller to move forward, it is considered a power boat even if its sails are up.

### 2. Meeting Head-On

When two boats meet head-on neither boat has right-of-way. Both boats should decrease speed, sound one short blast and pass; port to port. For starboard to starboard passing, each vessel should sound two short horn blasts and pass starboard to starboard. See Figure C1.

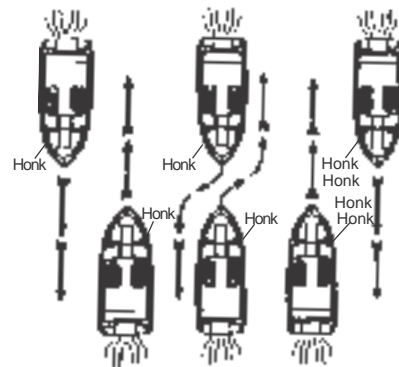

Figure C1: Meeting Head-On

### 3. Crossing Situations

In a crossing situation, the boat on the right from the 12-4 o'clock position has the right-of-way. It must hold course and speed. The boat without the right-of-way must keep clear and pass to the stern. See Figure C2.

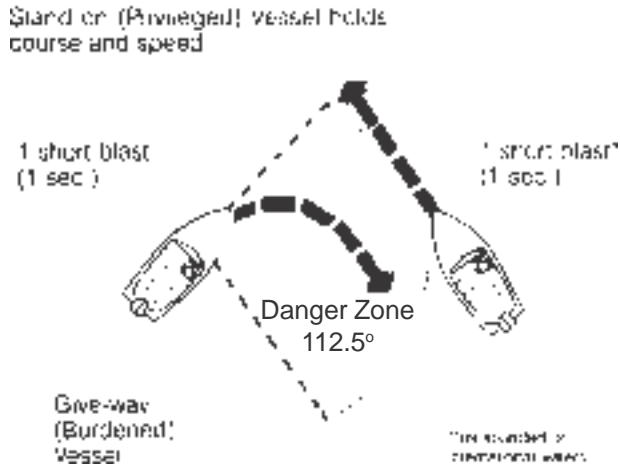

Figure C2: Crossing Situation

### 4. Overtaking

The boat overtaking the one ahead must yield the right-of-way to the boat being passed. The overtaking boat must make necessary adjustments to keep out of its path. The boat being passed should hold its course and speed. See Figure C3.

#### Inland Rules

"I want to pass you on your port side."

2 short blasts (1 sec.)

"Proceed"

2 short blasts (1 sec.)

#### International Rules

"I am altering my course to port."

2 short blasts (1 sec.)

#### International Rules in Narrow Channels

"I intend to pass you on your port side."

2 prolonged blasts (4-6 sec.)  
2 short blasts (1 sec.)

"Proceed."

1 prolonged, 1 short  
1 prolonged, 1 short

#### Stand-on (Privileged) Vessel Being Overtaken

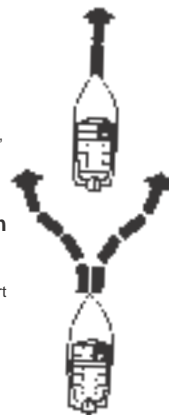

#### Give-way (Burdened) Vessel Overtaking

#### Inland Rules

"I want to pass you on your starboard side."

1 short blast (1 sec.)

"Proceed"

1 short blast (1 sec.)

#### International Rules

"I am altering my course to starboard."

1 short blast (1 sec.)

#### International Rules in Narrow Channels

"I intend to pass you on your starboard side."

2 prolonged blasts (4-6 sec.)  
1 short blast (1 sec.)

"Proceed."

1 prolonged, 1 short  
1 prolonged, 1 short blast

Figure C3: Overtaking

### 5. The General Prudential Rule

The general prudential rule regarding right-of-way is that if a collision appears unavoidable, neither boat has right-of-way. As prescribed in the "Rules of the Road", both boats must act to avoid collision.

### 6. Night Running

Boats operating between sunset and sunrise (hours vary by state), or in conditions of reduced visibility, must use navigational lights. Nighttime operation, especially during bad weather or fog, can be dangerous. All "Rules of the Road" apply at night, but it is best to slow down and stay clear of all boats regardless of who has right-of-way.

To see more easily at night, avoid bright lights when possible. Also, it is helpful to have a passenger keep watch for other boats, water hazards, and navigational aids.

To determine the size, speed and direction of other vessels at night, you should use running lights. A green light indicates the starboard side, and the red light indicates the port side. Generally, if you see a green light, you have the right-of-way; if you see a red light, give way to the other vessel. See Figure C4.

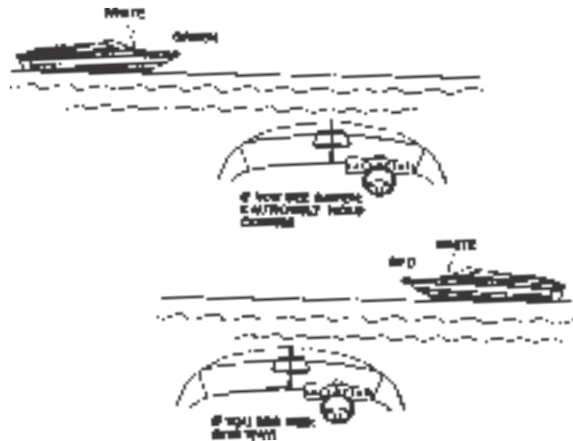

Figure C4: Night Running

### 7. Whistle Signal

Out on the water, whistle signals are commonly used. Although using a whistle signal is not necessary every time a boat is nearby, operators must signal their intentions when necessary to avoid potentially confusing or



hazardous situations. Use whistle blasts early enough to be noticed and understood by other boaters.

It is customary for the privileged boat to signal first and the yielding boat to return the same signal to acknowledge she understands and will comply. Use the danger signal (five or more short and rapid blasts) if intent is not clear. A short blast is one (1) or two (2) seconds long. A long blast is four (4) to six (6) seconds long. The Navigational Aids Chart at the end of this section lists the meanings of the various whistle signals.

## C - 2 NAVIGATIONAL AIDS

Aids to navigation (ATONS) help you to travel safely on the water. They help you get from one place to another and are most helpful if you have a nautical chart. A navigational aids chart is at the end of this section.



### WARNING

NEVER tie your vessel to an ATON. It is illegal because it blocks the ATON from view of other boaters. Decreased visibility can contribute to a serious accident which may result in property damage, personal injury, or death.

There are two ATON systems. The system used on federal waters is known as the International Association of Lighthouse Authorities System B (IALA-B). The Coast Guard maintains this system. The second system is the Uniform State Waterway Marking System (USWMS). This system is maintained by state authorities.

### A. International Association of Lighthouse Authorities System B (IALA-B)

IALA-B uses four types of ATONS. This section discusses the two most common markers: lateral markers and safe water markers. Other federal markers include special markers and isolated danger markers. The Navigational Aids Chart at the end of this section shows these aids.

### B. Lateral Markers

Lateral markers indicate the sides of navigable channels. They consist of lighted can or nun buoys and daymarks. Each has a number and is either red or green. The numbers on the green markers are odd. Red markers have even numbers.

Buoys are red or green floating ATONS. If lighted, they have either red or green lights. Unlighted green buoys, called cans, look like cylinders. Unlighted red nun buoys have a cone shaped top with their points cut off. Do not pass too close to a buoy. You may foul the propeller in its chain.

### NOTICE

Buoys are anchored floating objects and may not always be in exactly the same position.

Daymarks are red or green boards with numbers. They are on posts or groups of pilings tied together and called dolphins. Daymarks and their supports are daybeacons. Daybeacons may or may not have lights. If a red or green daybeacon has a light, it is the same color as the marker-red or green. Red daymarks are triangular and have even numbers. Green daymarks are square and have odd numbers.

Red, Right, Returning is a basic rule to assist you in using lateral markers. When you are returning from seaward, keep red markers on the starboard (right) side when you pass them. Keep green markers to the port side.

Returning from seaward is very clear if you have been on the ocean. You are returning to port. By agreement, going upstream on a navigational river is returning from seaward. The outlet ends of the Great Lakes are also the seaward ends. Traveling from a large body of water to a smaller one is considered returning from seaward.

### C. Safe Water Markers

Safe water markers have vertical red and white stripes and mark the center of navigable channels and fairways. Safe water markers included both lighted and unlighted buoys and daymarks. If a marker is lighted, the light is white and flashes the letter "A" in Morse Code.

Preferred Channel markers have horizontal red and green bands. If lighted, the color of the light is the same as the top of the band. They show the preferred channel for you to use at a junction point. Be sure to notice the color of the top of the band, and treat it as any other marker you would of that color. If the band is red and you are returning from seaward, keep the marker to the right.

Most lights on markers flash on and off. Others such as lights on aids with no lateral significance are fixed. They stay on all night. ATON lights flash in regular patterns.



For example, they may flash every three seconds, or in groups such as two flashes and a pause. There are a number of flashing patterns, which help you identify the light at night. To identify a light, note its color and pattern or timing of flashes, and compare it to your chart to find its location.

**D. The Uniform State Waterway Marking System**

This section discusses three kinds of markers in this system: Regulatory, Informational, and Lateral.

Regulatory markers in this system are either signs or buoys. Signs are square with orange borders. Regulatory buoys are white and shaped like cylinders. They have horizontal orange bands near their tops and just above the water’s surface. An orange circle on a marker means a controlled area. A message such as “No Wake, Idle Speed, No Skiing, or 5 M.P.H.” may appear on a marker. An orange diamond means danger. If a diamond has an orange cross inside it, do not enter the area. The reason you should stay out, such as “Swim Area” may be printed in black on the marker.

Informational Markers are white signs with orange borders. They give information such as direction, distance, and location.

Lateral markers in the USWMS system are either numbered red or black buoys. Black buoys may have green reflectors or lights. They are the equivalent of green buoys in the IALA-B system. Red buoys may have red reflectors or lights. They are the same as red buoys in the IALA-B system. Red or black buoys are usually found in pairs - pass between them.

**E. A Special Sign**

In Florida, you may see a special sign: “Caution, Manatee Area”. When you see this sign, slow down to idle speed. Manatees, an endangered species, are passive, large, slow-moving mammals. Many Manatees are seriously injured or killed each year by boat propellers.

**F. Noise**

Always be aware of local laws on noise limits. Noise means engine noise, radio noise or even yelling by people on your boat. Good seamanship demands that you operate your boat quietly so as not to infringe on the rights of others. Do not use thru-hull exhaust unless you are well offshore.

**G. Anchoring**

The weight of the anchor and diameter of anchor line should be governed by the size and weight of your boat. Keep anchor secure while underway to prevent damage or injury due to sudden shifting in the boat’s attitude.

Use two or more anchors if anchoring overnight or for extended periods. If not using two anchors, make certain there is sufficient clearance for your boat to swing in a full circle to prevent damage in case of shifting winds.

Make certain you have enough anchor line (or scope) for the depth of water. Your anchor line should be 6 to 7 times the depth of water anchored in. For example, if you are in 20 feet of water, use 120 to 140 feet of anchor line.



**CAUTION**

Secure anchor line to bow eye or deck cleat. Never tie anchor line to a rail, rail fitting or other hardware not designed to support this stress.

To drop anchor:

Approach your selected anchoring site from downwind and come to a dead stop over the spot where you want to drop anchor. Lower the anchor manually or by using the windlass if applicable.

Maneuver the boat slowly backwards until length of anchor line is 6 or 7 times the depth of the water.

Fasten the anchor line around the bow eye or deck cleat. Anchor flukes should dig in and catch. Watch for anchor drag by checking shoreline landmarks at the time the anchor is dropped and one-half hour later. If the boat has drifted away from these reference marks, the anchor is dragging and must be reset.

To weigh anchor:

Start the engine running before pulling in anchor.

Slowly maneuver the boat forward to reduce tension on the line and make retrieval of the anchor line easier.

Raise the anchor manually or by using the windlass if applicable. Make sure the chain stop is engaged if windlass is used. Properly stow anchor and anchor line.



**Always be sure to raise and secure the anchor prior to operating your boat.** Failure to raise and secure anchor before getting underway could result in severe injury or damage to boat from rebounding anchor.



Always utilize the chain stop provided with the windlass/bow roller combination. The chain stop prevents the anchor from accidentally releasing while the boat is moving thus preventing damage to the boat or possible injury or death to individual(s) aboard the boat.

If the anchor becomes stuck, attach the vertical line to the mooring cleat. Wave action on the bow may lift flukes from the bottom and free the anchor. If the anchor is still stuck, feed out a few feet of line and attach it to the bow cleat. Maneuver the boat around the anchor, keeping the line firm. Determine the angle that will work to pull the anchor free.

Anchors are available in different shapes, sizes and weights to fit different boats, uses, and conditions. Your Four Winns dealer can tell you which anchor will work best for your boat.

**C - 3 RECOMMENDED READING**

We recommend that you read the boating literature published by your state boating agency and the U.S. Coast Guard. Other suggested reading includes the following:

Damford, Don. Anchoring. (ISBN 0-915160-64-1). Seven Seas.

United States Coast Guard Auxiliary. Boating Skills and Seamanship. LC74-164688.(illus.). (ISBN 0-930028-00-7). U.S. Coast Guard.

Bottomley, Tom. Boatman's Handbook, (illus.). 316 p. (ISBN 0-688-03925-1, Hearst Marine Book). Morrow.

Whiting, John and Bottomley, Tom. Chapman's Log and Owner's Manual. 192 p.(ISBN 0-686-96737-2). Hearst Marine Book.

Chapman, Charles F. and Maloney, E.S. Chapman's Piloting, Seamanship and Small Boat Handling. (illus.). 62 p. (ISBN 0-87851-814-2, Pub. by Hearst Bks.); deluxe ed. (ISBN 0-87851-815-0). Morrow.

National Fire Protection Association. Fire Protection Standard for Pleasure and Commercial Motor Craft. (ISBN 0-317-07388-5, NFPA 302). National Fire Protection Association.

Brotherton, Miner. Twelve- Volt Bible. (ISBN 0-915160-81-1). Seven Seas.

**C - 4 CONTACTS**

There are many good boating publications that have information about your area and what other boats are doing, such as clubs and other activities. Education programs are sponsored by publications and organizations such as the U.S. Power Squadron, U.S. Coast Guard Auxiliary and the American Red Cross. See your dealer about special courses available in the area. For detailed information contact:

American Red Cross  
Local address (see local telephone directory)

Boat U.S. Foundation for Boating Safety Hotline  
1-800-336-BOAT  
1-800-245-BOAT (in Virginia)

U.S. Coast Guard Info Line  
1-800-368-5647

NMMA Sources of Waterways Information - National Marine Manufacturers Association has five (5) booklets which list sources for safety, cruising, and local waterway information. Each covers a different region of the U.S. (North Central, South Central, Northeastern, South-eastern and Western). For single copies, write Sources of Waterways information, NMMA, 401 N. Michigan Avenue, Chicago, Illinois 60611. Ask for the booklet for your region.

Skippers Course  
GPO Superintendent of Documents  
Washington, DC 20012  
202-512-1800  
202-512-2250 (fax)

United States Coast Guard Auxiliary  
Local Flotilla or contact appropriate Coast Guard District Headquarters

United States Coast Guard Headquarters  
 2100 2nd St., SW  
 Washington, D.C. 20593-0001  
 202-267-1060

United States Power Squadron  
 P.O. Box 30423  
 Raleigh, NC 27617

## C - 5 OWNER'S LOGS AND RECORDS

At the end of this owner's manual are several forms which you will find very helpful.

The **Float Plan** provides a record of your destination, departure and return times, boat description, passenger list, and other information about the trip you have planned. At the bottom of the form is space for listing emergency telephone numbers in case your return is delayed past the expected time. It also has space for indicating information about the person filing this report. Leave the completed form ashore with a responsible person. We recommend you make several copies of this form each boating season to assure an ample supply.

The **Fuel Log** is a handy way to record information covering engine hours, fuel consumption, miles traveled, as well as RPM (revolutions per minute), average M.P.H. (miles per hour) and GPH (gallons per hour).

The **Service/Maintenance Log** provides a record of maintenance work completed, the date of completion, and the engine hour reading. This log also helps you identify the frequency of routine maintenance work, such as engine oil changes. If you should decide to sell your boat, it demonstrates to prospective buyers that you have done a good job taking care of it.

The **Service Information Sheet** allows you to record all the pertinent information regarding your Four Winns® boat. This sheet will be extremely helpful when ordering additional/optional parts for your boat or when having service work done.

## C - 6 NAVIGATIONAL AIDS CHART

The illustrated Navigational Aids Charts contain information concerning whistle signals, storm warnings, bridge signals, and buoy descriptions. See Figure C5 on the following page.

# Navigational Aids Chart

**REMEMBER THESE RULES**

1. OVERTAKING - PASSING: Boat being passed has the right-of-way. KEEP CLEAR.
2. MEETING HEAD ON: Keep to the right.
3. CROSSING: Boat on right has the right-of-way. Slow down and permit boat to pass.

<p><b>← PORT</b></p> <p>Yield right-of-way to boats in your DANGER ZONE!</p> <p><b>STARBOARD →</b></p> <p>DANGER ZONE (Dead ahead to 2 points abaft your starboard beam)</p>	<p><b>STORM WARNINGS</b></p> <table style="width: 100%;"> <tr> <td style="text-align: center;"></td> <td style="text-align: center;"></td> <td style="text-align: center;"></td> <td style="text-align: center;"></td> </tr> <tr> <td style="text-align: center;">RED FLAG Small craft (winds to 33 knots)</td> <td style="text-align: center;">2 RED FLAGS Gale (winds up to 47 knots)</td> <td style="text-align: center;">SQUARE RED FLAG BLACK BOX (Storm)</td> <td style="text-align: center;">2 SQUARE RED FLAGS BLACK BOX (Hurricane)</td> </tr> </table>					RED FLAG Small craft (winds to 33 knots)	2 RED FLAGS Gale (winds up to 47 knots)	SQUARE RED FLAG BLACK BOX (Storm)	2 SQUARE RED FLAGS BLACK BOX (Hurricane)
RED FLAG Small craft (winds to 33 knots)	2 RED FLAGS Gale (winds up to 47 knots)	SQUARE RED FLAG BLACK BOX (Storm)	2 SQUARE RED FLAGS BLACK BOX (Hurricane)						
<p><b>WHISTLE SIGNALS</b></p> <p>ONE LONG BLAST: Warning signal (Coming out of slip)</p> <p>ONE SHORT BLAST: Pass on my port side</p> <p>TWO SHORT BLASTS: Pass on my starboard side</p> <p>THREE SHORT BLASTS: Engine(s) in reverse</p> <p>FOUR OR MORE BLASTS: Danger signal</p>	<p><b>BRIDGE SIGNALS</b></p> <table style="width: 100%;"> <tr> <td style="width: 50%; vertical-align: top;"> <p><b>SOUND</b></p> <p>VESSEL: Open </p> <p>BRIDGE: OK </p> <p>No </p> <p>VESSEL: Replies: </p> <p><b>RADIO: VHF CH. 13</b></p> </td> <td style="width: 50%; vertical-align: top;"> <p><b>VISUAL</b></p> <p>VESSEL: Open </p> <p>BRIDGE: OK </p> <p>No </p> <p>DAY (Flag) </p> <p>NIGHT (Lights) </p> </td> </tr> </table>	<p><b>SOUND</b></p> <p>VESSEL: Open </p> <p>BRIDGE: OK </p> <p>No </p> <p>VESSEL: Replies: </p> <p><b>RADIO: VHF CH. 13</b></p>	<p><b>VISUAL</b></p> <p>VESSEL: Open </p> <p>BRIDGE: OK </p> <p>No </p> <p>DAY (Flag) </p> <p>NIGHT (Lights) </p>						
<p><b>SOUND</b></p> <p>VESSEL: Open </p> <p>BRIDGE: OK </p> <p>No </p> <p>VESSEL: Replies: </p> <p><b>RADIO: VHF CH. 13</b></p>	<p><b>VISUAL</b></p> <p>VESSEL: Open </p> <p>BRIDGE: OK </p> <p>No </p> <p>DAY (Flag) </p> <p>NIGHT (Lights) </p>								

**LATERAL AIDS AS SEEN ENTERING FROM SEAWARD**

<p><b>PORT SIDE</b> ODD NUMBERED AIDS</p> <p> GREEN LIGHT ONLY</p> <p>FLASHING </p> <p>OCCULTING </p> <p>QUICK FLASHING </p> <p>ISOPHASE </p> <p> LIGHTED BUOY G "g" Fl G 4sec</p> <p> CAN G C "7"</p> <p> DAYMARK G "1"</p>	<p><b>SAFE WATER MID-CHANNELS OR FAIRWAYS</b> NO NUMBERS — MAY BE LETTERED</p> <p><input type="checkbox"/> WHITE LIGHT ONLY    MORSE CODE</p> <p>Mo (A) <input type="checkbox"/> <input type="checkbox"/> <input type="checkbox"/></p> <p> SPHERICAL RW SP "G"</p> <p> MR RW "A"</p> <p> LIGHTED AND OR SOUND RW "N" Mo (A)</p> <hr/> <p><b>PREFERRED CHANNEL</b></p> <p>COMPOSITE GROUP FLASHING (2 + 1)</p> <p><input type="checkbox"/> <input type="checkbox"/> <input type="checkbox"/> <input type="checkbox"/> <input type="checkbox"/> <input type="checkbox"/></p> <p> GREEN LIGHT ONLY GR "C" Fl (2 + 1)</p> <p> RED LIGHT ONLY RG "B" Fl (2 + 1)</p> <p> CAN PREFERRED CHANNEL TO STARBOARD TOPMOST BAND GREEN GR C "L"</p> <p> CAN PREFERRED CHANNEL TO PORT TOPMOST BAND RED RG N "W"</p> <p> DAYMARK JG A GR "A"</p> <p> DAYMARK JR B RG "B"</p>	<p><b>STARBOARD SIDE</b> EVEN NUMBERED AIDS</p> <p> RED LIGHT ONLY</p> <p>FLASHING </p> <p>OCCULTING </p> <p>QUICK FLASHING </p> <p>ISOPHASE </p> <p> LIGHTED BUOY R "8" Fl R 4sec</p> <p> NUN R N "6"</p> <p> DAYMARK TR 2 R "2"</p>
----------------------------------------------------------------------------------------------------------------------------------------------------------------------------------------------------------------------------------------------------------	---------------------------------------------------------------------------------------------------------------------------------------------------------------------------------------------------------------------------------------------------------------------------------------------------------------------------------------------------------------------------------------------------------------------------------------------------------------------------------------------------------------------------------------------------------------------------------------------------------------------------------------------------------------------------------------------------------------------------------------------------------------------------------------------------------------------------------------------------------------------------------------------------------------------------------------------------------------------------	---------------------------------------------------------------------------------------------------------------------------------------------------------------------------------------------------------------------------------------------------------------------------

Figure C5: Navigational Aids Chart

# WARRANTY AND SERVICE

## D - 1 FOUR WINNS WARRANTY POLICY

The Four Winns Winning Edge™ Owner Protection Plan, provides the new Four Winns purchaser with one of the most comprehensive corporate commitments in the marine industry today. The Four Winns Owner Protection Plan defines the warranty coverage on all units manufactured by Four Winns. It thoroughly describes the warranty policies and those procedures to be followed to obtain warranty coverage. Review the Four Winns Owner Protection Plan and limited warranty statements carefully.

All engines utilized in the Four Winns® product are warranted by the engine manufacturer. Your Four Winns dealer is authorized to repair your engines and will work closely with the engine manufacturer to resolve any problems you have.

## D - 2 DECK/HULL STRUCTURE WARRANTY

Each unit manufactured by Four Winns is encompassed by a separate warranty providing specific coverage on the deck/hull structure. The Four Winns Owner Protection Plan thoroughly describes this coverage.

## D - 3 WARRANTY REGISTRATION

A Four Winns Warranty Registration Card is attached to the Four Winns Owner Protection Plan statement. Your Four Winns dealer is responsible for completing and mailing the warranty card at the time of purchase. The receipt of the warranty card is the sole basis for establishing proof of ownership of the boat and corresponding warranty validation.

By signing the warranty registration card you, the new owner, indicate an understanding of the terms and conditions of the Limited Warranty. The warranty registration card should be properly completed by the dealer, signed by the new owner, and returned to us within fifteen (15) days after the original purchase in order to validate the warranty. This is a dealership's responsibility. Be sure to keep the Owner's Registration Card for your records.

All boat manufacturers are required by The Federal Boat Safety Act of 1971 to notify first time owners in the event any defect is discovered "which creates a substantial risk of personal injury to the public." In order for us to notify you if necessary, be sure to verify the accuracy of the embossed Winning Edge™ card upon receipt. You should receive your Winning Edge™ card within approximately 30 days from the day of your boat purchase. If you have not received your Winning Edge™ card within this time frame please contact your Four Winns selling dealer for resolution. If upon receipt of the card you discover a discrepancy, please notify Four Winns L.L.C. at 231-775-1343. A corrected Winning Edge™ card will then be sent to you.

Other equipment manufacturers also require that their products be registered with the respective companies. Warranty registration cards are provided in the owner's information packet.

## D - 4 TRANSFER OF WARRANTY

Four Winns confidence in the product and our warranty commitments can extend after the original purchaser may choose to move on to a new boat. The remainder of the Four Winns warranty coverage is transferable to the second owner of the boat for a fee. The warranty may be transferred only once. Registration of the second owner is required and the amount of the transfer fee is indicated on the warranty statement of the Warranty Registration Card. Transfer of the remainder of the warranty must occur within five (5) years of the original retail sale. The transfer fee must be paid within fifteen (15) days of purchase of the used boat by check, money order or cashier's check payable to Four Winns. Proof of purchase date is required. We will notify the appropriate engine manufacturer of the boat warranty transfer. The Four Winns Owner Protection Plan thoroughly describes the action required to transfer warranty coverage.

## D - 5 PRE-OWNED UNIT REGISTRATION

Section D-4 Transfer of Warranty discusses the need to properly register the purchase of a pre-owned boat with Four Winns in order to transfer applicable warranty coverage.



Purchasers of all Pre-Owned Four Winns® models, regardless of the decision to transfer warranty coverage, are encouraged to register ownership with Four Winns. To register ownership of a “Pre-Owned Four Winns® boat,” provide Four Winns with your name, address, daytime phone number, e-mail address, purchase date, and hull serial number of the boat purchased. The hull serial number plate is permanently affixed to the starboard side of the transom.

Registration of a Pre-Owned Four Winns® boat does not extend or in any way affect or modify the specific terms of the Four Winns Owner Protection Plan or Limited Warranties.

We provide this service to the purchasers of Pre-Owned Four Winns® boats in the interest of better boating. Four Winns welcomes every purchaser of a Four Winns® boat, new or used, to our family.

#### **D - 6 INSURANCE COVERAGE**

One of your responsibilities as a new boat owner is to acquire proper insurance protection. Insurance should include comprehensive and general liability coverage appropriate to your financial needs. Please contact your local agent for assistance on insurance coverage.

#### **D - 7 SERIAL NUMBER RECORD**

The manufacturer, model, and serial number of major components are recorded during the assembly of each Four Winns® boat. A copy of this form is included in the owner’s packet. Using this form, you may want to have your dealer help you complete the service information form at the back of this manual. A copy of the serial number record should be made and kept by the dealer in his records. This can assist the dealer in processing warranty claims, or obtaining necessary information. The original copy of the serial number record should be kept in the owner packet. The service information form should remain in the owners manual for easy reference.

#### **D - 8 PRE-DELIVERY SERVICE**

Four Winns makes every effort to deliver your boat in “turn key” condition to the dealer. The process of transporting and handling the boat necessitates certain inspections and adjustments prior to delivery to you. Also, various aspects of operation must be checked and adjusted immediately prior to final delivery and use.

The selling Four Winns dealer must perform this thorough review of the boat and its numerous systems during the commissioning or “dealer pre-delivery service” of the craft.

A Four Winns Pre-Delivery Inspection Form is part of the Warranty Registration Card. It lists the many items encompassed by the pre-delivery service previously described. The dealer is to check off the items as they are completed, and complete the form as indicated providing specific performance related information appropriately.

Your Four Winns dealer will sign the Pre-Delivery Inspection Form of the Warranty Registration Card upon completion of the work. You will also be asked to sign the Pre-Delivery Inspection Form upon accepting delivery of the boat. You are to retain the two copies marked “Boat Owner”. Your dealer is to retain the copy marked “Dealer copy” for his records. The Manufacturer’s copy is to be mailed to the Four Winns Customer Service Department.

#### **D - 9 REPLACEMENT PARTS**

Four Winns dealers are equipped with a Four Winns parts manual that details the components of each model and their appropriate part numbers. Many Four Winns dealers inventory common replacement components.

In addition, Four Winns maintains specific records on the components used in the manufacture of each unit and makes a concerted effort to maintain components specifically to fill replacement part needs.

The Four Winns dealer from whom you purchased your boat is in the best position to meet your needs. If the dealer does not have the needed item, the dealer has the capability, through direct contact with the Four Winns Customer Service Department, to obtain it quickly. Four Winns will only sell replacement parts to established Four Winns dealers. If you relocate and cannot find a Four Winns dealer close to you, contact the Four Winns Customer Service Department for information on the nearest dealer in your area.



## D - 10 OWNER'S RESPONSIBILITIES

1. Sign the warranty registration card verifying your address, model and hull serial number. The dealer is responsible for mailing the warranty registration card to us.
2. Inspect the boat at the time of delivery to verify that all systems and components are operating safely and acceptably. Read all manuals and instructions.
3. Operate all equipment in compliance with the manufacturer's instructions.
4. Review the pre-delivery checklist for the boat and engine with your dealer when you take delivery.
5. Schedule your 20-hour boat and engine checkup with your dealer.
6. Know how to safely operate your boat and the rules of the road before you use your boat.

**IMPORTANT:** Make sure that your dealer checks the engine alignment during your boat's 20-hour checkup. The engine alignment check should be performed in accordance with recommended procedures as stated by the engine manufacturer in your engine owner's manual. Failure to do so could result in drive train damage which is not covered under the warranty.

7. We recommend that you review your engine owners manual and warranty certificate for break-in advice, initial inspection and service requirements.
8. Perform or provide for the scheduled maintenance checks outlined in this manual and all related service guides and manuals.
9. You are responsible for any modifications made to the boat or its equipment that could affect the safe operation of the boat.

Along with boating, comes responsibility. Responsibility for safety, boating laws, and the environment. Please think about the future of our waterways, oceans and marine life while you're out enjoying them and take all necessary measures to help protect what natural habitats we have left. Keeping our waterways and marine habitats free from debris, and showing consideration for the creatures who thrive in these environments are some ways you can help assure the pleasure of boating for years to come.

The operator is also responsible for complying with the following procedures and operational requirements:

- State registration
- Insurance
- Warranty registration
- Warranty terms and conditions
- Rules of the road
- Break-in procedure
- Proper maintenance of the boat and its systems
- Safety equipment
- Safety training of passengers and crews
- Knowledge of boat systems
- Seaworthiness/operational inspection
- Safe operating practices
- Avoiding use of drugs/alcohol
- Environmental regulations
- Accident reporting

## D - 11 CONSTRUCTION STANDARDS

All our boats meet or exceed the construction standards set by the U.S. Coast Guard and the American Boat and Yacht Council (ABYC) concerning:

- Navigational lights
- Factory installed fuel systems
- Engine and fuel tank compartment ventilation
- Flotation
- Steering systems
- Backfire flame arresters

We recommend that you see your dealer if you wish to modify factory-installed equipment or add new equipment. Your dealer is qualified to make such modifications or additions without placing the safety or design integrity of your boat at risk and without invalidating the warranty.

## D - 12 WINN GEAR™

Show your colors! Four Winns offers a complete line of sports clothing designed to complement your new boat. Your Four Winns dealer has a complete catalog and pricing. Our Winn Gear™ line is also on display on our website at [www.fourwinns.com](http://www.fourwinns.com).

# ENGINES AND INSTRUMENTATION

## E-1 GENERAL



### WARNING

DO NOT attempt to service any engine without being totally familiar with the safe and proper service procedures. Do not attempt to maintain or adjust an engine while it is running. Certain moving parts are exposed and failing to shut off the engine can result in serious injury or death.

Four Winns does not manufacture engines. Because of the technical nature of the engines, all manufacturers of these items require that warranty and service problems be taken directly to an authorized dealer for resolution. The Four Winns dealer from whom you purchased your boat will handle all warranty and service matters with the engine manufacturer for you.

In compliance with the Federal Boat Safety Act of 1971, all engine manufacturers require their products to be registered. A registration card is furnished with each new engine. When selling a Four Winns® boat, the dealer, along with the purchaser, should complete the information requested on these cards and return them to the respective engine manufacturers. Engine registration cards are provided with the engine and will usually be found with the owner's information packet.

Each manufacturer of the various marine power components provides an owners information manual with their product. This publication is included with this manual. It is important that you read the manual(s) carefully and become completely familiar with proper care and operation of the engine system. Be sure to read the section on winterization. Replacement costs associated with frozen engine components are quite substantial.

Also review the other sections in this manual, especially Sections I on Fuel Systems, and Section F on Control Systems.

## E-2 ENGINE EXHAUST

The carbon monoxide in exhaust fumes can be hazardous. It is important for you and your passengers to be aware of the potential safety hazard created by exhaust fumes. Familiarize yourself with the symptoms of individuals overcome by carbon monoxide, and most importantly, ways you can protect yourself and your guests.



### WARNING

DO NOT inhale exhaust fumes! Exhaust contains carbon monoxide which is colorless and odorless. Carbon monoxide is a dangerous gas that is potentially lethal.

Persons overcome by carbon monoxide may exhibit the following symptoms:

- a. Watering and itchy eyes
- b. Flushed appearance
- c. Throbbing temples
- d. Inattentiveness
- e. Inability to think coherently
- f. Ringing in the ears
- g. Tightness across the chest
- h. Headache
- i. Drowsiness
- j. Incoherence
- k. Nausea
- l. Dizziness
- m. Fatigue
- n. Vomiting
- o. Collapse
- p. Convulsions

**IF YOU THINK EXHAUST FUMES ARE ENTERING YOUR BOAT, DETERMINE THE CAUSE AND HAVE IT CORRECTED IMMEDIATELY!**

The following suggestions can help prevent exhaust fumes from entering the boat:

1. DO NOT allow the boat to remain stationary with the engine running for an extended period of time. Do not stand or swim near the exhaust output or outdrive when the engine is idling.

2. Use extreme caution while operating the engine in confined areas such as enclosed slips or congested piers. Operation under such conditions could easily lead to exhaust gasses (carbon monoxide) entering even though you may have all the hatches, windows, doors and portholes closed.
3. Persons sleeping can be easily overcome by carbon monoxide because they are unaware of its presence. Sleeping while the engine is running is not recommended. If persons are sleeping aboard while underway, those awake should monitor for carbon monoxide accumulation in the cabin; especially the sleeping areas.



**WARNING**

NEVER operate the propulsion engine while everyone on-board is sleeping. Fatal carbon monoxide poisoning can occur.

For additional information, refer to Section B-2 Carbon Monoxide.

**E - 3 ENGINES**

Consult the Engine Owners Manual included in the owner's packet for additional operation and maintenance information.

**E - 4 PROPELLERS**

Knowledge of the propeller is most easily gained through better understanding of the terminology used to refer to the aspects of propeller size and performance.

**NOTICE**

Never run with a damaged propeller. You can damage the engine or drive unit. Keep a spare propeller on board.

**A. Diameter**

Diameter is twice the distance from the center of the prop shaft to the extreme tip of a propeller blade. Increasing or decreasing propeller size will have a direct bearing on the rpm's (revolutions per minute) an engine will develop. This is due to the greater amount of propeller blade surface in contact with the water. See Figure E1.

**B. Pitch**

Pitch is a measure of helix angle, or angle of attack, of the rotating blade. Pitch is easily understood if one imagines the propeller rotating through a semisolid such as butter or jello. The distance through the propeller will travel in one revolution is called "Pitch." Increasing or decreasing pitch will also have a direct bearing on engine rpm's because of the greater bite taken by the blade with each rotation. See Figure E1.

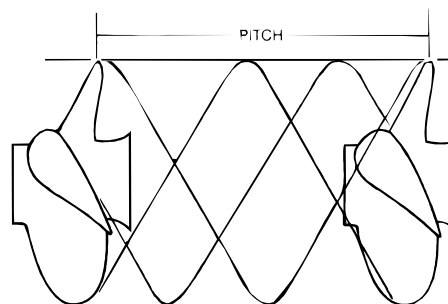
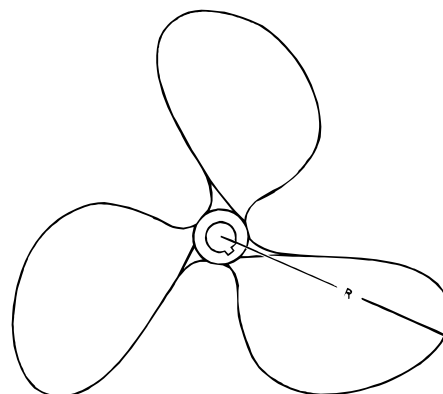

Figure E1: Propeller Pitch & Diameter

**C. Prop Slip**

When traveling through water a propeller is unable to get a complete bite because of the fluidity of water. "Prop Slip" is usually expressed as a percent of the computed theoretical speed. Fifteen to twenty-five percent prop slip is common for a sport-type boat operating at cruising speed.

Changing either diameter or pitch will have an effect on engine speed and prop slip, and in turn, directly affect the performance of a boat. The propeller(s) included with each

Four Winns® boat provide the best general performance based on data obtained from on-the-water testing of that model. Variations in load, operating conditions, environment, the individual engine and hull performance may necessitate the purchase and use of another propeller(s).

Under your normal load conditions the engine(s) should turn within the maximum rpm range when at full throttle. If the engine(s) exceeds the recommended rpm, an increase in pitch and/or diameter is required. If the engine rpm is too low, a decrease in pitch and/or diameter is required.

An engine that is not developing full power and the load carried in a boat will directly affect performance of the engine. Always be sure the engine is properly tuned and load conditions are those normally experienced, before changing propellers.

For additional information on factors affecting performance, please consult your Four Winns dealer.

**E - 5 RUNNING ANGLE & POWER TRIM/TILT**

Hull planing surfaces have the least amount of drag at a three to five degree angle with the water. This is the preferred running angle when boating. The running angle has a significant impact on top speed and handling. See Figure E2. Heavy load or certain water conditions may make it difficult to achieve the optimum running angle. The running angle can be controlled through the use of the power trim.

**A. Power Trim**

Trim angle is how far in or out, the drive or outboard motor is positioned in relation to the bottom of the boat. The trim angle of the drive has a distinct affect on the running angle of the boat.

The power trim system permits control of the trim angle of the drive relative to the boat, at the touch of a button. It allows the drive to be raised for shallow water operation. Power trim also allows the operator to adjust the drive while underway to provide the ideal running angle for a given load and water condition. Additional information can be found in the engine operator's manual included in the owner's packet.

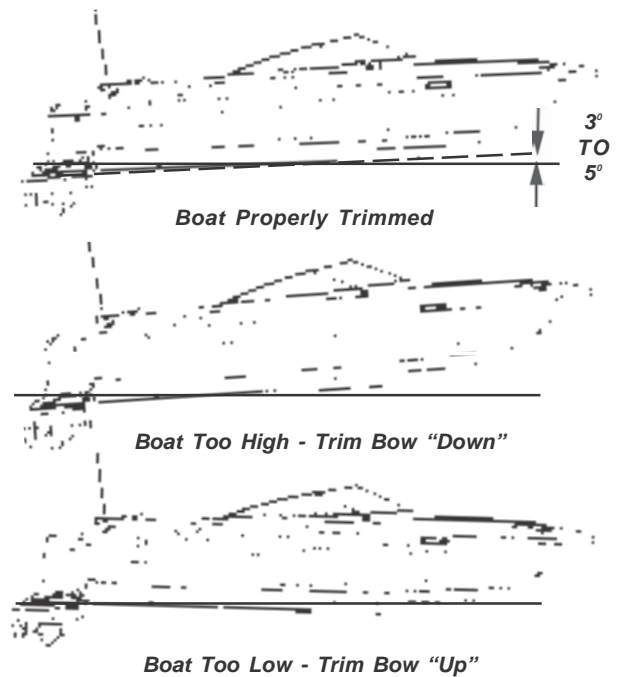

Figure E2: Running Angle

**B. Power Tilt**

Power tilt allows the operator to raise and lower the drive for trailering, launching, and beaching. Additional information on power tilt can be found in the engine operator's manual included in the owner's packet.

**NOTICE**

DO NOT operate the motor with the water intakes out of the water. Severe damage to the engine systems can result. Consult the engine operator's manual for specific information.

**E - 6 TRIM TABS**

Electric/hydraulic trim tabs are available on certain models. Trim tabs help provide maximum control of the hull in all water and load conditions. Used properly, trim tabs can:

- a. Compensate for wind and load listing (level the boat side to side).
- b. Induce faster planing and help achieve optimum running angle (see Section E-5 - Running Angle & Power Trim/Tilt).

The proper use of electric/hydraulic trim tabs requires a basic understanding of trim tab operation and some practice in calm water. Be sure to read the manufacturer's literature included in the owner's packet.

The trim tab control uses two (2) momentary-type rocker switches. The trim tab switches control the attitude or position of the boat. The trim tab switches are labeled by position such as "Bow Up" and "Bow Down". They are also labeled for "Port" and "Stbd". When pressed, the label indicates what happens to the bow of the boat.

Before leaving the dock and utilizing the trim tabs, ensure the trim tabs are in the full up position. Press both lower halves of the trim tab switches and hold (for approximately 10 seconds) until the tabs are full up.

### A. Control Listing

Wind, loading and many other factors can result in the boat tilting or leaning towards one side while running. This is called listing and can be negated using trim tabs.

Pressing the lower port trim tab switch will move the starboard trim tab upward. This will result in the port bow of the boat being allowed to rise.

Pressing the lower starboard trim tab switch will cause the port trim tab to move upward and will result in the starboard bow being allowed to rise.

Pressing the upper port trim tab switch will cause the starboard trim tab to move downward and will force the port bow downward.

Pressing the upper starboard trim tab switch will cause the port trim tab to move downward and will force the starboard bow downward.

Always establish your intended heading and attain desired cruising speed before trying to adjust running attitude (using the trim tabs).



#### **WARNING**

Always press the trim tab switches in short one (1) second bursts. If pressed too long, you can overcompensate, and potentially lose control. DO NOT try to correct the situation by pressing the other upper trim tab switch. Instead, raise the tab slightly by pressing the appropriate lower half of the trim tab switch.

After stabilization of speed and direction, press the upper half of the appropriate trim tab switch to achieve a level side to side running attitude. Be sure to press the correct trim tab switch to obtain the desired result.

After pressing a trim tab switch, always wait and allow time for the change in trim tab position to take effect. DO NOT continue to press the trim tab switch while awaiting trim tab reaction. By the time the effect is noted, the trim tab will move too far and thus overcompensate.

### B. Induce Planing & Controlling Trim Angle

Trim tabs can also be used to facilitate faster planing and allow better control of the running angle.

Before accelerating and trying to gain plane, press both upper trim tab switches. This will cause both trim tabs to move downward and force the bow down when running. This can also be used when running the boat with a heavy load aboard.

Moving the trim tabs downward will increase the lift and the boat will achieve plane faster, or stay on plane at a lower engine and boat speed.

After gaining plane and establishing cruising speed, pressing both lower trim tab switches will cause both trim tabs to move upward and will allow the bow to rise. This should be used to adjust the running attitude of the boat to decrease the drag at cruising speed or above, or when running in a following sea.

When running at an engine speed that results in the boat falling off plane or causes the boat to plane inefficiently, lowering both tabs slightly (bow down) will improve the running angle and improve operating efficiency.

Optimum efficiency is obtained when operating at a 3 to 5 degree running angle. Utilizing too much "Bow Down" trim tab can reduce operating efficiency and cause substantial steering and handling difficulties. Be extremely careful when running in a following sea. The effect of trim tabs is amplified under such conditions. Steering and handling difficulties can result from improper trim tab usage, especially in a following sea. If unsure of proper trim tab positioning, raise the trim tabs to the full-up position.



**WARNING**

When running at high engine speeds, be sure the trim tabs are in the full up position. Trim tab action should be only enough to compensate for any listing. Trim tab adjustments at high speeds are extremely critical. Be prepared to slow down should handling difficulties arise.

When running in a displacement (very slow speed) mode, better efficiency will be obtained with the trim tabs in the full-up position.

**C. Trim Tab Maintenance**

Check the fluid level of the trim tab reservoir often. Always keep the fluid level between the designated marks on the trim tab pump-reservoir. Refer to the manufacturer's information for specifications on the type of fluid to be used and other operation and maintenance information.

**E - 7 INSTRUMENTATION**

The helm station on Freedom™/Horizon™ models are equipped with a complete set of individual engine instrument gauges. These instrument gauges allow the boat operator to constantly monitor the operational condition of the engine. Close observation of these instrument gauges could save the engine from damage. See Figures E3 & E4 for examples of helm layouts.



Figure E3: Helm Station



Figure E4: Helm Station - Twin Engine

**A. Tachometer**

The tachometer indicates the speed of the engine in revolutions per minute (rpm). This speed is not the boat speed or necessarily the speed of the propeller. The tachometer may not register zero with the ignition key in the OFF position. Note: Some models come with a tachometer/hour meter combination gauge which allows for hour meter viewing at the helm. Please refer to Section E-7K - Engine Hour Meter for information regarding the engine hour meter.

**NOTICE**

Never exceed the maximum recommended operating rpm of your engine. Maintaining maximum, or close to maximum rpm for extended periods can reduce the life of the engine.

Some engines are equipped with devices that limit engine rpm in accordance with the oil pressure, or engine temperature. Refer to the engine manual included in the owner's packet for additional information.

The tachometer must be set for different engines installed. This is typically done at the factory. The tachometer gauge is shown along with the table detailing the tachometer settings. See Figure E5.



## FARIA TACHOMETER SETTINGS



Set switch to match your engine.  
**CAUTION:** Depress switch slightly while turning.

TACHOMETER SETTINGS	
NUMBER OF CYLINDERS	ENGINE SETTING
4*	1
6*	2
8*	3
12 POLE	4
(OR ALT)	
* 4 CYCLE ONLY	

Note: Setting information is labeled on the back of the tachometer.

Figure E5: Tachometer - Rear View

### B. Speedometer

The speedometer is a water pressure sensitive unit. It has a pick-up (pitot tube) assembly mounted on the transom and a small plastic hose (speedo tube) that connects it to the speedometer gauge on the dash. See Figure E6. The pitot tube extends below the hull. Water strikes the tube inlet and creates positive pressure. The faster the boat speed, the greater the pressure, and the higher the speed indication on the speedometer.



Figure E6: Speedo Sender

If the pick-up becomes clogged, the speedometer will not register. Clean the opening with a piece of wire or disconnect the tubing and blow out the pick-up with compressed air.

When winterizing the boat, the speedometer tubing must be drained of water. Disconnect the speedometer hose at the pick-up assembly and at the gauge and blow through the tubing to remove the water.

#### NOTICE

Speedometers are not precision instruments. The indications are relative and should never be used for navigational purposes or similar critical situations.

#### CAUTION

DO NOT rely on the speedometer when trying to achieve a "NO WAKE" condition in a harbor or other enclosed waterway. ALWAYS reduce throttle! Speedometers are not effective at measuring low operational speeds. You are responsible for damage caused by the wake of your boat.

### C. Temperature Gauge (4-in-1 Gauge)

The temperature gauge included in the 4-in-1 gauges monitor the cooling system of the engine. A sudden increase in the temperature could be a signal of a blocked cooling passage or a water pump malfunction.

#### NOTICE

Operation of an overheated engine can result in engine seizure. If an unusually high temperature reading occurs, shut the engine off immediately.

### D. Oil Pressure Gauge (4-in-1 Gauge)

The oil pressure gauge indicates the pressure in the engine lubrication system. A significant drop in oil pressure is a possible indication of an oil pump or other leakage problem.

If the engine has been equipped with an audible engine alarm, the alarm should sound if the oil pressure drops below the normal operating range of the engine. Please see your engine owner's manual for specific engine information.

#### NOTICE

Operation of an engine with abnormally low oil pressure can lead to engine damage and possible seizure. Have the engine serviced immediately upon a reduced oil pressure indication.

#### E. Voltmeter (4-in-1 Gauge)

The voltmeter monitors battery condition and thus alternator performance. See Section H for additional information regarding electrical systems.

#### F. Fuel Gauge (4-in-1 Gauge)

The fuel gauge displays the level of fuel that is present in the fuel tank. The fuel gauge will operate when the ignition switch supplying power to the fuel gauge is in the RUN position.

Due to the mechanical nature of the fuel sender, variations in readings during various speeds of operation may occur. This system is merely a relative indication of the available fuel supply and not a calibrated instrument. Refer to Section I-1E - Fuel Senders for additional information.

#### NOTICE

Use only clean fuel of the type and grade recommended by the engine manufacturer. The use of incorrect or contaminated fuel can cause engine malfunction and serious damage. Refer to Section I - Fuel Systems for additional information.

#### G. Power Trim Gauge

Boats equipped with stern drives also have a “power trim gauge.” This gauge provides a visual indication of the inward-outward (trim angle) position of the outdrive. There is not a trailer travel mode on the gauge.

#### H. Depth Sounder

The depth sounder is standard equipment on most models. It consists of two main components, the transducer and the depth sounder. The transducer is mounted to the hull and the depth sounder is installed in the dash. The transducer and depth sounder communicate by means of a cable, and are powered by your boat’s 12-volt DC battery. The transducer and depth sounder use the basic principle of sonar to indicate the water’s depth. Please read the manufacturer’s literature included with the owner’s packet for information regarding operation and maintenance.



Do not rely on depth sounder to avoid submerged objects. Depth sounders provide a relative indication of water depth only.

#### NOTICE

DO NOT depend solely upon the depth sounder for water depth. It is important to have navigational charts of the waters in which you are operating.

#### I. Four Position Ignition Switch

Most models use an ignition switch with four positions: OFF, RUN, ACCESSORIES, and START. Just like the three position switch, the START position is spring loaded and the key should be held in this position until the engine starts. The key will return to the RUN position once released. Always turn the key to the OFF position when the engine is not running. This will prevent discharging of the battery(s). The ACCESSORIES position allows the operator to run the stereo without activating the other ship’s systems. Additional information on ignition switch operation is covered in Section A Operation, of this manual.

#### J. Emergency Stop Switch

This safety device automatically stops the engine if the lanyard is attached to the operator and the operator falls from his work station. Refer to the engine manual for detailed information about using this switch.

The emergency stop switch (Figure E7) incorporates a shutoff switch, switch clip, lanyard, and lanyard clip. The lanyard clip must be securely attached to the operator’s PFD, clothing, arm, or leg. Be sure to attach the lanyard to a place where it is free of obstructions and to something that will move with the operator if he or she leaves the helm station. If the engine shuts down because this switch was activated, the clip may have to be reinstalled on the interrupter switch before the engine can be started.



Keep emergency stop switch lanyard free from obstructions that could interfere with its operation. Do not modify or remove emergency stop switch or bypass its safety features. The proper use of the emergency stop switch will prevent a runaway boat situation which can cause severe personal injury or death.

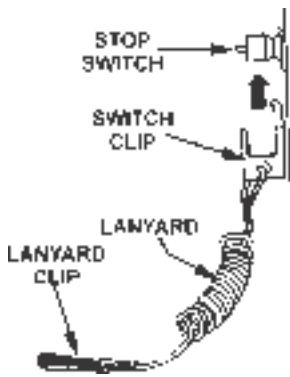

Figure E7: Emergency Stop Switch

The emergency stop switch can only be effective when in good working condition. Observe the following:

1. Lanyard must always be free of entanglements that could hinder its operation.
2. Once a month, check the switch for proper operation. With engine running, pull lanyard. If the engine does not stop, see your Four Winns dealer.
3. Once a month, inspect both the clip and lanyard for cuts, breaks or wear. Replace worn or damaged parts.

In an emergency situation, any occupant of the boat can restart the engine. Just press in and hold the emergency stop switch button, then follow normal starting procedures. When the button is released, the engine will stop.

**CAUTION**

Avoid knocking or pulling the clip or lanyard from the switch during regular boating operation. Occupants may be thrown forward or possible engine damage may occur by the sudden loss of engine power.

**K. Engine Hour Meter**

Engine hour meters are available on certain models and provide a numeric record of elapsed engine operating time. This information is important in determining scheduled maintenance intervals, ships log data, cruise information, etc. If so equipped, the hour meter will be located at the helm with the tachometer/hour meter combination gauge.

The hour meter is connected to the ignition switch. The hour meter will be energized when the ignition switch is in the RUN position. Be sure the ignition switch is in the OFF position when the engine is not operating or the hour meter will record additional time. Turning the ignition key to the ACCESSORY position will not activate the hour meter.

**L. Alarm Systems**

Engine alarm systems are available on certain engine options. The alarm is audible and is actuated by various engine sensors. The sensors monitor such things low oil pressure, high water temperature levels and high exhaust manifold temperatures. Consult your engine owner's manual for information regarding the specific systems monitored by the alarm if so equipped.

**M. VHF Radio - (Optional)**

Also available for certain specific models is an optional VHF radio. The VHF radio option consists of a VHF radio, console mounting kit, an antenna, and antenna mount. Please consult the manufacturer's literature included in the owner's packet for operation and maintenance of this communication system.

**NOTICE**

Four Winns continually strives to improve its products. Unit specifications, including standard and optional equipment are constantly being modified. Equipment availability is also subject to change without notice. The most current and accurate information available at the time of publication is included in this manual. Some variation in equipment, description, location, and details can result.

**N. Compass**

A compass is available on many Four Winns® models. The compass can provide directional information when operating offshore, in unfamiliar waters, or in adverse weather conditions.

The compass must be properly calibrated after all personal equipment is installed including all electronics (radio, depth sounder, etc.). DO NOT rely on the compass readings until initial adjustment (compensation) has been performed. The boat has a factory installed compass, the manufacturer's instructions are provided in the owner's packet. Most areas have local companies that specialize in compass adjustment. If unsure of the proper com-

pensation techniques, consider having the adjustment done professionally to ensure accuracy and confidence in the compass.

**NOTICE**

During use, keep all extraneous metal objects away from the compass. The close proximity of metal objects (e.g., beverage cans) can cause compass deviation.

**O. Fish Finder**

The fish finder is standard equipment on models with Fish & Ski package options. The fishfinder mounts in front and to the right of the starboard helm console. It can swivel from helm seat to forward fishing seat allowing viewing from either position. If equipped, please refer to the manufacturer's literature, included in the owner's packet, for operational information.

**P. Instrument Maintenance**

Electrical protection for instruments and ignition circuitry is provided by fuses. The fuse block is located underneath the starboard dash on most models or on the starboard side, below the throttle control, near the floor on other models.

Periodically, spray the ignition switch with a contact cleaner. The ignition switch and all instruments, controls, etc. should be protected from the weather when not in use. Four Winns offers appropriate weather covers for each model. Excessive exposure can lead to gauge and ignition switch difficulties.



**CAUTION**

DO NOT use a product such as WD-40 as a contact cleaner. Be sure to read the label before using any product.

Electronic gauges are affected by static electricity that builds-up on the glass face. Periodic washing on the gauge face with warm water and mild liquid detergent will help eliminate the static electricity problem and improve gauge accuracy.

# CONTROL SYSTEMS

## F - 1 GENERAL

Control systems permit operation of the engine's throttle and shift mechanisms. They consist of three major components; the shift control, throttle control, and the throttle and shift cables. Additional information on shift control operations can be found in Section A-9.

Most Freedom™/Horizon™ models are equipped with a single lever concealed side mount control. A gaffrig style shift and throttle controls are featured on certain Horizon™ models only. See Figure F1 & F2. These controls allow you to select forward or reverse gear, regulate engine speed, and ensures shifting is done at low engine speeds.

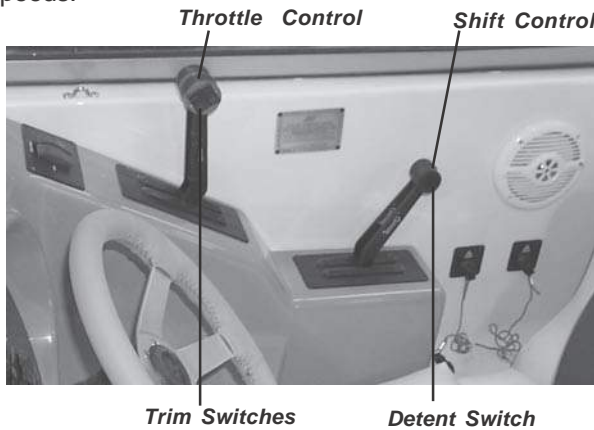

Figure F1: Gaffrig Shift and Throttle

A “start-in-neutral-only” feature which prevents starting in gear is included on both styles of controls. Refer to F-3 Neutral Safety Switch in this section.

Also, the side mount control and gaffrig shift control has a neutral lock button to prevent accidental shifting. It must be depressed to permit shifting from neutral to forward or reverse.

Built into the side mount control is a trim control switch which you can use to adjust the position of the out drive. This trim control switch is mounted in the gaffrig's throttle control. A twin engine application would have two trim control switches. Pressing the switch in the UP position moves the outdrive out and away from the transom. Pressing the switch in the DOWN position moves the outdrive in closer to the transom. The switch returns to its center neutral position when released. For additional information see Section E-5.

Neutral is in the center or straight up position on the side mount control. Placing the gaffrig shift control to the center or straight up position also places the engine(s) in neutral. Rotating the shift control forward shifts the engine into forward. Rotating the shift control aft shifts the engine(s) into reverse. Moving the lever further forward or aft increases engine speed on the side mount control while an individual throttle control lever is used on the Horizon™ models with gaffrig style controls .

**NOTICE**  
When shifting, ensure engine speed is below 800 RPM to avoid damaging the shifting mechanism.

**NOTICE**  
Allow the engine to warm up before engaging the shift control. Monitor all instruments while engine is idling during warm-up.

Specific information on controls and their operation can be found in the section on “Starting and Operation” in the engine manufacturer’s manual included in the owner’s packet.

## F - 2 SIDE MOUNT CONTROL OPERATION

### A. Carbureted Engines

The shift mechanism on the controls can be disengaged to allow for easier starting and engine warm-up. See Figure F2. To disengage:

1. Place control handle in neutral position (B).
2. Press both neutral lock button (A) and shift disengage button (C).
3. Move control handle forward to increase throttle.

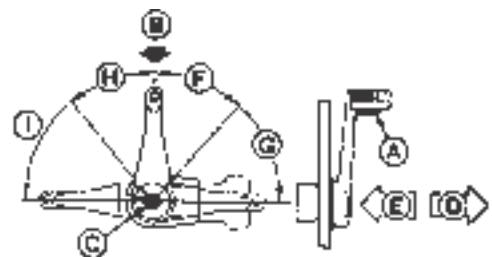

Figure F2: Side Mount Control Operation



The neutral lock and shift mechanism will automatically engage when the control handle is returned to the neutral position.

4. Shift Mechanism Engaged (D).
5. Shift Mechanism Disengaged (E).
6. Reverse Shift Range (F).
7. Reverse Throttle Range (G).
8. Forward Shift Range (H).
9. Forward Throttle Range (I).

Refer to the engine manual, included in the owner's packet, for additional information on control operation.

**B. Fuel Injected Engines (EFI)**

On fuel injected engines, starting the engine is much easier and faster. It is not necessary to use the throttle while in neutral to cold-start the engine. Simply turn the key and allow the engine to warm up.

For additional information, refer to the section on "Starting and Operation" in the engine manufacturer's manual included in the owner's information packet.

**F - 3 NEUTRAL SAFETY SWITCH**

Control systems usually incorporate neutral safety switches within their design. This device prevents the engine from being started while the shift lever is in any position other than the neutral position. If the engine will not start, slight movement of the shift lever may be necessary to locate the neutral position and disengage the safety cut-out switch. Control or cable adjustments are required to correct this condition should it persist. See your Four Winns dealer for necessary control and cable adjustments.

**F - 4 CONTROL SYSTEM MAINTENANCE**

Periodic inspections of the control, cables, and all connections should be made. Signs of looseness, rust, corrosion, wear, cable jacket cracks or other deterioration require immediate system servicing. Replace all damaged components.

Generally, periodic lubrication of all moving parts and connections with a light, waterproof grease is in order. Cables can be lubricated by positioning them to their fullest extension and applying light grease to the inner cable near the jacket. Working the cables back and forth will distribute the grease in the inner cable. Reapply the grease if necessary.

Lubrication should be performed as often as necessary to keep the system operating smoothly. Cable manufacturers such as Teleflex® and Morse® often offer special tools to make cable lubrication easier.

Cable and control adjustments may become necessary. Adjustment screws in the control, on the cables and in the linkage are provided.

WARNING

DO NOT attempt control adjustments unless you are familiar with control systems service procedures. Control misadjustment can cause loss of control.

Other lubrication, adjustment and maintenance instructions are provided by the control manufacturer and are included in the owner's information packet.



# STEERING SYSTEMS

## G - 1 GENERAL

Four Winns® boats are equipped with rotary or hydraulic-type steering systems. Tilt and power steering are available on most models.

### A. Rotary Steering

In the rotary system, a rotary drum assembly is mounted under the dash behind the steering wheel with a one piece cable running through the boat into the engine compartment. At the transom, the cable turns and is connected to the engine. Additional information on steering operation can be found in Section A-9.

### B. Tilt Steering

If equipped with tilt steering, depress the release lever (adjusting tab) with your thumb to tilt the steering wheel. Be sure to hold the top of the wheel to assist in positioning. Release the lever once the steering wheel is in the position desired. See Figure G1. Refer to the steering manufacturer's literature, included in the owner's packet, for additional information.

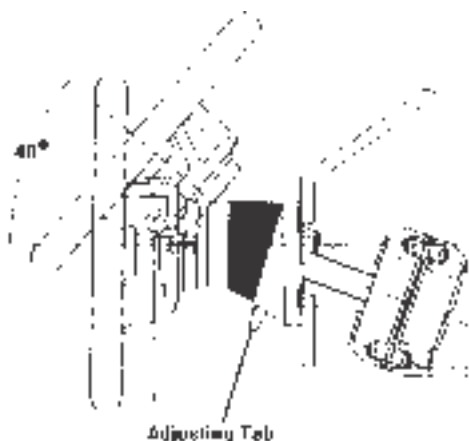

Figure G1: Tilt Steering Option



The tilt mechanism should not be adjusted when the boat is moving. Sudden boat movement may cause loss of balance resulting in loss of control and/or injury.



The tilt mechanism is spring loaded. Due to the variation in steering wheel offerings, the wheel may spring up rapidly when depressing the release lever. ALWAYS KEEP ONE HAND ON THE WHEEL DURING TILT ADJUSTMENT OR INJURY MAY OCCUR.

### C. Power Steering

Power steering, featured on most models, is comprised of an engine mounted pump, hoses and steering cylinder. Power steering works in conjunction with the helm and steering cable to move the transom mount tiller arm and vertical drive more smoothly.

This is a “power assist” system and can greatly reduce steering effort required. It is not, however, a full power steering system as is used in automobiles. Some steering tension remains in the system.

On models with power steering, restricting movement of the steering cable will limit or stop the steering system's hydraulic assist.

### NOTICE

DO NOT interfere with or restrict steering cable movement through the last 90° of bend at the engine. DO NOT use cable retainers, clamps or tie straps. Using one or all of these could restrict the cable movement near the engine. DO NOT tie wiring harnesses or other control cables to the steering cable. Make sure the deck coaming pads and bulkheads allow for steering cable movement in all positions of trim.

If the power steering becomes inoperative, steering will be harder and more effort will be needed to steer the boat. Check for a broken or loose belt on the power steering pump. Also, low fluid levels in the power steering pump reservoir will cause hard steering. If these items are not the source of the problem, check for equipment or other items lying on or up against the steering cable at the back of the boat. The cable must be free and clear to slide back and forth. Any item blocking free movement of the cable will result in harder steering and possible damage to the steering cable.

If the power steering system cannot be corrected on board, proceed at a reduced speed. The boat will be steerable, but with increased effort. Return the boat to your Four Winns dealer as soon as possible to correct the power steering system.



**CAUTION**

If equipped with power steering, check the fluid level in the reservoir periodically. Low power steering fluid levels may increase steering difficulty.



**CAUTION**

After the first two hours of running time, check the entire steering system for loose bolts, nuts and fasteners which could adversely affect steering control.

**NOTICE**

When storing equipment in the engine compartment, be sure to avoid contact with the steering cable. Cables may become kinked or damaged and may increase steering effort.

**NOTICE**

DO NOT force the steering unit to either extreme. This can place undue strain on the unit and can lead to hydraulic line or seal failure.

It is important that the power steering fluid be maintained at the proper level. Do not over fill the power steering pump reservoir. Please consult the section in the engine manual regarding steering system and maintenance. The engine manual is included in the owner's packet. Also included in you owner's packet is the steering manufacturer's literature.

**D. Hydraulic Steering**

The hydraulic steering system is comprised of the helm pump and reservoir, hydraulic hoses, and the hydraulic cylinder. The helm assembly acts as a pump to move the oil through the system. In many aspects this type of steering is similar to the mechanical system. Instead of activating a cable, turning of the helm causes fluid in the hydraulic hoses to flow and activate the hydraulic cylinder causing the rudders or outboards to turn. See Figure G2.

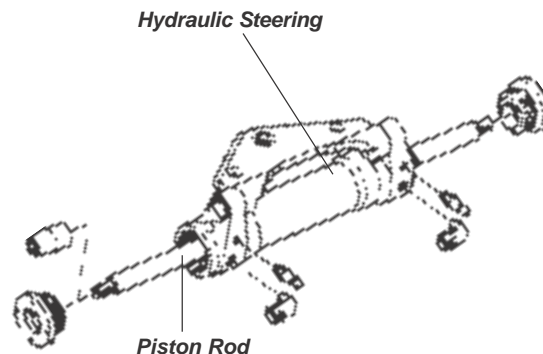

Figure G2: Hydraulic Steering

Upon commissioning the boat, it is necessary to purge the system of air. This is performed by your Four Winns dealer during pre-delivery service. Should steering difficulty increase with time, it is possible additional bleeding of the system is required. See your Four Winns dealer for assistance. This and other adjustments on power steering units are critical and should be performed only by a qualified service technician.

**NOTICE**

If equipped with the hydraulic system, a slight clicking sound may be heard as the wheel is turned. This sound is the opening and closing of valves in the helm unit; this is normal.

**G - 2 PROPELLER TORQUE**

The propeller rotation of a single engine installation will exert a directional force on the steering system. This can cause the steering to be harder in one direction than the other, and is called propeller torque. If this occurs, adjust the drive or outboard's trim tab (when applicable). Refer to the engine manual, included in the owner's packet, for information on adjusting the trim tab.

Propeller torque can also cause the boat to wander (not follow a straight line) when operated at low speeds. This condition is normal and can be corrected only by increasing engine rpm. Wind, water currents and play in steering components can cause equivalent effects.



**CAUTION**

Steering effort can vary significantly with engine acceleration, steering angle, trim angle, and sea condition. Be prepared for additional steering loads at all times.

**G - 3 STEERING SYSTEM MAINTENANCE**

**A. General Maintenance**

A periodic inspection of all steering cables, linkage and helm assemblies should be made. Signs of corrosion, cracking, loosening of fastenings, excessive wear, or deterioration should be immediately corrected. Failure to do so could lead to steering system failure and corresponding loss of control.

**NOTICE**

Check all bolts, nuts and fasteners for tightness.

**B. Rotary System Maintenance**

The helm and cable assembly should be so adjusted that the steering wheel is centered with the drive or outboard engine in the straight ahead position. There should be an equal number of turns to port and starboard from the straight ahead position. If adjustment becomes necessary, see your Four Winns dealer.

Check all metal parts at the cable output end for corrosion. Remove any old grease from the cable ram and motor swivel connections using a mild solvent such as WD-40. Spray the cleaned areas with a moisture-displacing lubricant and apply a light coat of good quality marine grease. Do this with the ram fully extended. See Figure G3.

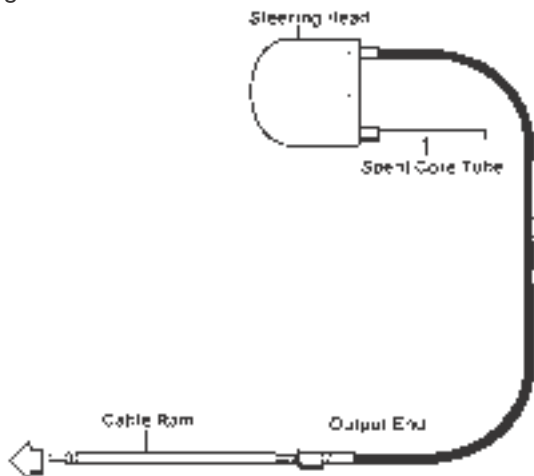

Figure G3: Steering Cable

**C. Hydraulic System Maintenance**

Hydraulic steering systems must periodically have all air purged from the system. Review the information provided by the hydraulic steering manufacturer for proper specifications and details on system service and maintenance.

**D. Winter Storage**

If the boat is placed in winter storage or used infrequently, clean the cable ram as instructed earlier. Cycle the steering several times when applying lubricant. If at any time the steering system becomes stiff, has an excessive amount of freeplay or shows any change in its operating characteristics, contact your Four Winns dealer to have the system inspected.

# ELECTRICAL SYSTEMS

## H - 1 GENERAL

All electrical equipment on Four Winns® boats operate on 12 volt DC electrical power.



### Fire or Explosion Hazard!

Electrical system parts are designed by and manufactured to comply with the U.S. Coast Guard requirements to minimize risks of fire or explosion. **Never substitute automotive parts for marine parts.** Automotive parts do not provide the necessary ignition spark protection.



To prevent equipment or electrical wiring damage, **DO NOT** tamper with any electrical connection, panel or harness, or attempt installation of any electrical equipment unless thoroughly familiar with the systems and are experienced in making such installations.

For detailed information on the electrical system wiring, electrical schematics are located in the back of this manual.

## H - 2 BATTERY SYSTEM

### A. Single Battery System

On most models, a single battery is provided as standard equipment (12 volt DC) per Section H-1 above. The dash components are protected by a fuse panel either located below the helm or starboard of the helm, below the throttle shift control. Refer to Figure H1 and to the wiring schematics located in the back of this manual.

When installing the battery, proceed as follows:

1. Connect the red (positive) cable running from the engine starter solenoid to the positive (+) battery terminal.
2. Connect the black (negative) battery cable running from the engine block to the negative (-) battery terminal.



When disconnecting the cables from the battery, make sure all switches are off and disconnect the black negative cable first to prevent spark.

### NOTICE

**DO NOT** disconnect the battery while the engine is running. Alternator damage could result.

Monitor the battery's condition regularly with the voltmeter in the dash panel. For additional information, refer to Section H-6 - Electrical System Maintenance.

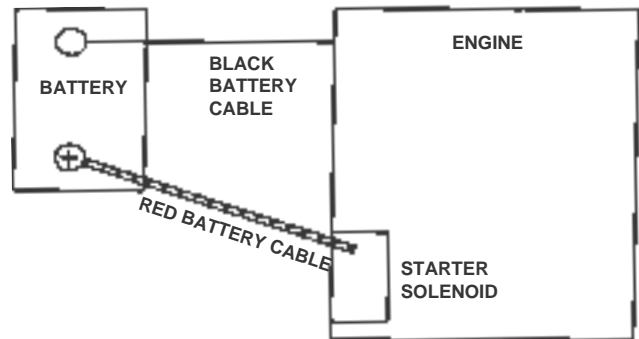

Figure H1: Single Engine-Single Battery Installation

### B. Dual Battery System

A battery selector switch is provided on single engine or twin engine dual battery installations. This allows DC power to be used from either one or both batteries. Refer to Figure H2.

When installing dual batteries, proceed as follows:

1. Connect each of the red battery cables leading from the battery selector switch to the positive (+) terminal on each of the two batteries.

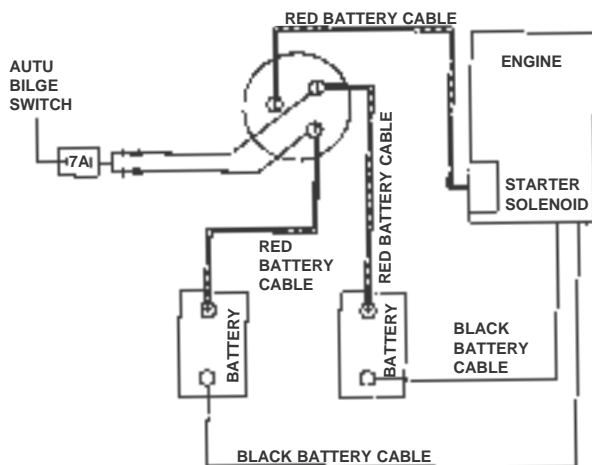

Figure H2: Single Engine-Dual Battery Installation

**NOTICE**

Be sure both cables are installed on the positive (+) battery terminals.

2. Connect the black battery cable to the port negative (-) battery terminal (see Section H-2). Connect the other black battery cable to the starboard negative (-) battery terminal.

**WARNING**

When disconnecting the cables from the battery, make sure all switches are off and disconnect the black negative cable(s) first to prevent spark.

**C. Battery Switch Operation - (Specific Models Only)**

Dual batteries with a selector switch is optional on certain models only. Power to the engine and all 12 volt electrical equipment with the exception of the automatic bilge pump is controlled by the battery selector switch. See Figure H2.

Dual battery selector switch positions:

“OFF” - With the battery selector switch in the “OFF” position, all 12 volt power to the boat is shut off completely except to the automatic bilge pump. A separate fuse is provided on the battery switch panel for the automatic bilge pump. Always turn the battery selector switch

to the “OFF” position when the boat is removed from the water.

**NOTICE**

DO NOT turn the battery selector switch to the “OFF” position while the engine is running. Alternator and wiring damage could result.

“1” - Turning the switch to position “1” will use battery #1 to power the engine and 12 volt equipment. Battery #2 will be isolated and remain in reserve. Only battery #1 will be charged by the alternator.

“2” - Turning the switch to position “2” will use battery #2 to power the engine and 12 volt equipment. Battery #1 is isolated and remains in reserve. Only battery #2 will be charged by the alternator.

“BOTH” - With the battery selector switch in the “BOTH” position, the batteries are connected in parallel. Both batteries will be used by the engine and all 12 volt equipment. Both batteries will be charged by the alternator. However, the batteries will charge at a slower rate compared to setting the switch in the other positions.

The use of one battery at a time is recommended. Position the battery selector switch to either the #1 or #2 position.

Under normal conditions, avoid using the “BOTH” position. Use the “BOTH” position only when a single battery is not capable of starting the engine.

Four Winns recommends alternating between batteries during boating. Depending upon boating use, this may increase battery longevity. Use battery #1 for the first day of a cruise and switch to battery #2 on the second day.

Position the battery selector switch to the battery that has sufficient power to start the engine (normally position “1”). After the engine is running, turn the battery selector switch to the battery that has the lowest charge. This will allow the alternator to charge the low battery. Utilizing the battery selector switch in this manner (instead of using the “BOTH” position) will supply a greater charge to the battery.

FOR EXAMPLE: If battery #1 is fully charged and battery #2 is in need of a charge, use battery #1 to start the engine. After the engine is running and warmed-up, turn the battery selector switch to the #2 position. This will permit the alternator to charge the low, #2 battery.



**D. Battery Switch Operation with “Emergency Start Only” Position**

The battery selector switch with “Emergency Start” position is standard on certain models only. A description of the various positions for the battery switch is as follows:

“OFF” - With the battery selector switches in the “OFF” position and the “SHIPS SYSTEMS” circuit breaker in the “OFF” position, all 12 volt power to the boat is shut off except to the automatic bilge pumps, stereo and windlass (if applicable). Always turn the battery selector switch to the “OFF” position when the boat is unattended for an extended period.

**NOTICE**

Twelve volt power to the cabin panel is supplied by the “SHIPS SYSTEMS” circuit breaker on the battery selector panel. This must be turned on to operate any 12 volt accessories on the cabin panel. The bilge pumps and stereo receive power from the ships system battery and remain on at all time regardless of battery selector or ship systems switch position.

**NOTICE**

DO NOT turn the battery selector switch to the “OFF” position while its corresponding engine is running. Alternator and wiring damage could result.

“ON” - Turning the switch to position “ON” will use the engine battery to power the engine and 12 volt engine related equipment. The ships system battery will not be used for any engine related equipment, but will power all other 12V equipment on the boat (when “SHIP SYSTEM” circuit breaker is on). The isolator will allow the alternator to fully charge the two batteries, but not allow the operator to drain down the engine start battery. “ON” is the recommended switch position for normal boat operation. This position allows maximum use of 12V equipment on the boat and leaves a full charge in the engine battery(s) for starting.

“EMERGENCY START ONLY” - With the battery selector switch in the “EMERGENCY START ONLY” position, the engine and ships systems battery are connected in parallel. Both batteries will be used by the engine and all 12 volt equipment. Both batteries will be charged by the alternator through the isolator.

**E. Battery Charger - (Excludes Fish & Ski Packages)**

A battery charger is available on certain Horizon™ models only and is located in the engine compartment. The batteries will be charged by the battery charger when the boat is connected to dockside power and the charger circuit breaker is in the “ON” position.

Additional information on the battery charger can be found in Section H-5B 110 Volt AC Equipment in this manual and refer to the manufacturer’s literature included with the owner’s packet.

**F. Fish & Ski Package**

Certain Freedom™/Horizon™ models are available with a Fish & Ski package option. This includes a 12-volt trolling motor, a separate battery for trolling motor, a built-in battery charger, aft livewell, rod holders, ski pylon (outboard models only), forward casting platform, fishing seats that double aft jumpseats, removable windshield wings and separate electrical console at the bow.

To charge the batteries using the built-in battery charger:

1. Using a grounded, extra heavy duty, marine grade extension cord, plug the female end into the battery charger inlet. See Figure H3.
2. Plug male end of extension cord into the 110 volt AC receptacle that is protected by a Ground Fault Circuit Interrupter (GFCI) breaker.



*Figure H3: Fish & Ski Built-In Battery Charger Inlet*

To disconnect the cord to the charger:

1. Unplug male end of extension cord from the 110 volt AC receptacle.



- Unplug female end of extension cord from the charger inlet.

**NOTICE**

The alternator, when engine is running, will charge the engine/boat systems battery only. The battery charger does charge both trolling motor and engine battery as needed and when power cord is plugged in.

**NOTICE**

Four Winns continually strives to improve its products. Unit specifications, including standard and optional equipment are constantly being modified. Equipment availability is also subject to change without notice. The most current and accurate information available at the time of publication is included in this manual. Some variation in equipment, description, location, and details can result. Please refer to the manufacturer's literature in the owner's packet.

**H - 3 12 VOLT ELECTRICAL EQUIPMENT**

**A. Helm Equipment**

The ignition, DC outlet, and dash panel switches are protected by a separate fuse panel located either below the dash at the helm station, or on the starboard side, below the throttle shift control, near the floor. Descriptions of individual switches are described in the following:



To avoid equipment damage or electrical fires, use only replacement fuses that are of equal rating to the original fuse. Refer to the electrical schematic included with this manual for proper sizes.

Horn - To sound the horn, push the HORN button.

12 Volt DC Receptacle - Permits the use of additional 12 volt equipment such as a cell phone. Using the appropriate adaptor, the equipment draws power from the boat's battery.

Aft Bilge Pump - The BILGE PUMP switch at the dash is used to manually activate the bilge pump in the engine compartment. The bilge pump is used to remove water from the bilge (bottom of the hull) area of the boat by pumping that water overboard.

On the Freedom™/Horizon™ models, the aft bilge pump is equipped with an automatic bilge switch and will operate whenever bilge water rises above the pump stop level. This will cause the internal float to move upward and activate the pump.

On models with battery selector switches, the automatic bilge pump will be active when the battery selector switch is in the "OFF" position. The automatic bilge pump circuitry is connected to a circuit breaker on the battery switch panel. Refer to Sections H-2C & H-2D for additional information on battery switch operation.

When leaving your boat unattended for an extended period, check the charge on the battery(s) periodically. Also check the water level in the bilge and make sure the float switch is functional.

If the automatic bilge pump must be disabled, disconnect the wiring plug near the bilge pump.

Bilge Blower- The BLOWER switch is used to activate the bilge blower. The bilge blower is used to remove any gas vapors that may have accumulated in the bilge or engine areas.



**Gasoline vapors can explode resulting in injury or death.**

- Before starting the engine, check the engine compartment bilge for gasoline or vapors.
- Operate blower for four (4) minutes, and verify blower operation. Run blower when vessel is operating below cruising speed.

To verify blower is operating place your hand over the vents. DO NOT rely on the sound of the blower. Be sure a substantial amount of air is being exhausted by the bilge blower. Check the bilge blower system often, preferably before each cruise.

Navigation & Anchor Lights - Moving the NAV/ANC LTS switch towards the NAV position activates the bow lights and the all-around light or both portions of the mast light. Move the switch to the ANC position to activate the all-around light or both the fore and aft portion of the mast light. The center switch position is OFF.

Wipers - The WIPER switch activates the windshield wiper. This feature is available on many of our Four

Winns® sportboat models. The wiper is mounted on the starboard (driver's) side.

**Trim Tabs** - If the boat is equipped with electric/hydraulic trim tabs, the trim tabs are controlled by the TRIM TAB switches. Refer to Section E-6 Trim Tabs for more information.

**Refrigerator (certain specific models only)** - The circuit breaker on the AC panel protects the refrigerator. The refrigerator will automatically operate on the 12 volt system or on the 110 volt system when using the dockside power. Using the 12 volt system can deplete the battery quickly, and excessive drain on the battery may cause irreparable battery damage. Dual battery installation is required for this feature. Refer to Section H-2D - Battery Switch Operation with "Emergency Start Only" Position and the owner's packet for the refrigerator operating instructions.

**Accessories** - Additional 12 volt equipment may be added to the boat using an accessory switch. Certain accessories may be wired directly to the fuse block below the dash. For more information, refer to Section H-3B - Installation of Additional 12 Volt Equipment.

**Cabin Lights** - Cabin lights are equipped with remote switches and are standard on all cabin models.

**Cockpit Lights** - The CKPT LTS switch is used to activate the cockpit (courtesy) lights.

**Docking Lights** - The DOCKING LTS switch is used to activate the docking lights.

**Engine Hatch** - The ENGINE HATCH switch is used to raise and lower the engine lid by activating a linear screw jack(s). Pressing the upper portion of the switch marked "UP" allows the engine lid to be raised. Pressing the lower portion of switch marked "DOWN" lowers the engine lid.

**Windlass (If applicable)** - The WINDLASS switches activates the windlass. Refer to the Section M-7 in this manual and the manufacturer's literature for additional information.

**Refreshment Center Sink** - The cockpit sink water pump is activated by the FRESH WATER switch located on the refreshment center or on the starboard helm console.

**Transom Washdown** - A water pump is installed in the engine compartment for the transom washdown system.

It is activated by the FRESH WATER switch located on the refreshment center or on the starboard helm console.

## B. Installation of Additional 12 Volt Equipment

On the fuse panel, non-factory installed 12 volt accessory equipment can be connected to the "ACC" terminal. Accessory equipment can also be wired directly to a newly installed "ACC" switch on the dash.



Be sure to provide proper fuse protection for all 12 volt equipment that is installed. Accessory current should be limited to 15 amps if the connection is made to the fuse block. If an "ACC" switch is used, again the current should be limited to 15 amps. Gauge(s) and/or 12 volt equipment may operate improperly and cause possible internal damage at higher levels.

## C. Interior Equipment

Four Winns offers a CD stereo as standard equipment on the Freedom™/Horizon™ models. The stereo may include a remote display at the helm depending on the model. An optional stereo remote may be installed at the swim platform on certain models. Please consult with your Four Winns dealer regarding availability.

Generally, the stereo is mounted either on the starboard helm or port console. On some models the stereo is concealed in the glovebox for added security and protection. The stereo's microprocessor is coated to help protect it from the elements. The stereo's faceplate is water resistant and the quick release door has a water-tight seal. For stereo operation, please refer to the manufacturer's manual included in the owner's information packet.

On certain models only, an optional 6-disc CD changer is available and is usually located in the starboard walk-thru storage compartment. For instructions on both the stereo and optional 6-disc CD changer, refer to the manufacturer's operation manual included in the owner's information packet.

Additionally, certain Freedom™/Horizon™ models come equipped with a satellite stereo receiver. Please see your Four Winns dealer for information and activation.

**H - 4 110(220) VOLT ELECTRICAL SYSTEM**

Certain Freedom™/Horizon™ models are equipped with 30 amp, 110 volt, 60 Hertz (or 15 amp, 220 volt, 50 Hertz) AC electrical wiring. When the boat is connected to a shore power outlet, the AC system supplies electrical power to the following items if so equipped: battery charger, refrigerator, and outlet(s). The dockside system uses three-wire, color-coded circuitry. The black or hot wire is the ungrounded current carrying conductor. The white or neutral wire is the grounded current carrying conductor. The green wire, referred to as the “equipment ground,” is a grounded conductor, and under normal conditions is not a current carrying wire. The neutral wires are connected together at a buss bar. The equipment grounds are similarly connected together at another buss bar. Each hot wire is connected to, and protected by, a circuit breaker in the AC panel. The AC panel is located inside the head or starboard walk-thru helm storage compartment.

Certain models equipped with a dockside system have a main circuit breaker which protects the overall distribution network. The MAIN dockside inlet is usually located on the transom. The MAIN circuit breaker protects both the hot and neutral input leads. This breaker is sensitive. The resulting power surge which occurs when connecting the shore power cord may cause the MAIN breaker to trip. To avoid this power spike, turn off the MAIN breaker before plugging in the shore power cord. Securely connect the power inlet of the boat and the shore power receptacle. Once the shore power is securely connected, turn the MAIN breaker back on. If the connection is broken and later re-secured, the circuit breaker may trip. Connections must be secure for uninterrupted dockside service.

**H - 5 DOCKSIDE OPERATION**

 **WARNING**

If any abnormalities appear during dockside operation, DISCONNECT the system immediately to prevent electric shock hazards! Have the boat’s electrical system and the shore side receptacles checked as soon as possible.

**A. Shore Power Connections**

 **WARNING**

To prevent electric shock hazards, use only equipment with approved three wire electrical plug connections. Be sure each item being used has been tested and is free of electrical shorts and ground faults.

Fifty foot, ten gauge, three wire, shore power cords are provided with dockside wiring. The shore power cords on 60 Hertz systems have 30 amp twistlock-type connectors. They have a power “ON” indicator light to ease in connecting and troubleshooting. This connector complies with the American Boat and Yacht Council (ABYC) standards.

Some marinas are not equipped with approved twistlock-type receptacles. An adaptor is available from Four Winns which converts the twistlock shore plug to a three wire grounded household type plug. Use only an approved adaptor when an adaptor is necessary.

 **WARNING**

DO NOT use a two-wire adaptor to connect to a three-wire system. These adapters do not provide adequate grounding.

Shore power connection procedure is as follows:

1. Turn off the boat’s main breaker switch before connecting or disconnecting the shore power cable.
2. Connect shore power cable at the boat first, then connect it to dockside shore power outlet.

**NOTICE**

Always connect the cord to the power inlet receptacle of the boat before making connections to the shore power source.

3. Check for reversed polarity before turning on the main breaker. If the reversed polarity light is activated, immediately disconnect the shore power cord. See Section H-6C Reverse Polarity Indicator.
4. To disconnect shore power, turn off the main breaker switch on the AC electrical panel and disconnect the power cord from the shore power dockside receptacle first. Then, disconnect the cord from the boat.

**NOTICE**

Always disconnect the shore power cord from the dockside first before disconnecting from the boat.

**B. 110 Volt AC Equipment**

All 12 volt equipment is isolated from the 110 volt AC system (except the refrigerator which is dual voltage). Appropriately labeled circuit breakers protect all AC systems on the boat. The receptacles can be used for 110 volt (220 volts on 50 Hertz models) household appliances. Refer to the following list for information on appliances and other equipment.

**Battery Charger** - On models with battery charger, the battery charger is controlled by a circuit breaker on the AC electrical panel and is labeled CHARGER/REFRIGERATOR. The circuit breaker must be on the "ON" position in order for the charger to charge the batteries when connected to shore power.

**Refrigerator** - The CHARGER/REFRIGERATOR circuit breaker must be on to operate on 110 voltage. If this breaker is off, the refrigerator will automatically operate on the 12 volt system. This can deplete the battery. Excessive drain on the battery may cause irreparable battery damage. The refrigerator will automatically operate on 110 volts when provided (with the circuit breaker in the ON position). Please refer to manufacturer's operating instructions included with the owner's packet.

**Receptacles** - The OUTLETS circuit breaker must be switched to the "ON" position to supply power for the corresponding receptacles in the AC system. (For those models with the receptacles built into the AC panel, power is supplied to the receptacles when shore power is provided.)

Most receptacle circuits are capable of handling 15 amperes. Refer to Table III for a list of equipment and the electrical currents usually required to operate these items. For 220 volt, 50 Hertz models, divide all of the current ratings below by 2. Usually, the power requirement is specified on the electrical item. This is only an approximation of the electric current usage normally experienced.

**Table III: Electrical Equipment**

EQUIPMENT	ELECTRICAL LOADS
Air Conditioners	See motor load plate
Battery Chargers	Up to 800 watts (7.3 amps)
Blankets (Electric)	50 to 200 watts (2 amps)
Coffee Makers	550 to 700 watts (6.3 amps)
Electrical Drills	See motor load plate
Fans	25 to 75 watts (0.7 amps)
Fry Pan	1350 watts (12.3 amps)
Heater	1500 watts (13.7 amps)
Lights	Wattage as marked
Television	1500 watts (10.5 amps)
Vacuum Cleaners	See motor load plate

**C. Reverse Polarity Indicator**

Improper grounds or reversed polarity at shore power are a source of serious electrical hazard. The reverse polarity light will indicate if a problem exists at the 110 AC electrical system shore connection.

If a problem exists, the Reverse Polarity Indicator Light will come on when the shore power cable is attached to the inlet. **DO NOT** activate the shore power breaker switch in the cabin when the Reverse Polarity light is on.



ALWAYS check the Reverse Polarity Indicator Light in the AC distribution panel immediately upon connecting the shore power cord before turning on the AC SHORE POWER circuit breaker. If the light is on, a problem with a reversed electrical connection exists. Disconnect the shore power cord immediately. Notify the marina and have the dock's shore power connection inspected.

Under proper operating conditions, the Reverse Polarity Indicator Light **will not** be on. A green light is provided for the shore power and will be ON when dockside power is being used.

**NOTICE**

Some marina shore power systems may be improperly grounded to retard electrolysis (see Section H-7 Stray Current Corrosion). Before using any 110 volt equipment, make sure the reverse polarity light does not activate when connecting the cord to the inlet.

**D. Ground Fault Current Interrupters (GFCI)**

The Ground Fault Current Interrupter (GFCI) is a device which protects against hazardous electrical shock from improper ground. An appliance electrical cord with worn insulation or damp equipment may have stray current which will run through electrical grounds. Stray current as above will result in an electrical shock.

One GFCI receptacle will protect all of the receptacles on the circuit. A GFCI may be used as a receptacle as well as an interrupter.

To test:

Push the black test button and the red reset button should pop out from the inner surface. The receptacle and the circuit are now off.

Push the red reset button in until it clicks to reset it. If it does not reset, there is either a short in the circuit or the equipment being used, or a ground fault in the equipment. Unplug all appliances and reset the GFCI. One at a time, plug the equipment back in and turn it on. The item that causes the GFCI to trip is the problem item and should **not** be used.

**H - 6 ELECTRICAL SYSTEM MAINTENANCE**

**A. Battery Maintenance**

Be sure to keep the batteries charged. Also, keep the batteries clean, especially the terminals and connection lugs. The battery cables must be fastened securely while in use.

Check the battery fluid level often, especially when a charger/converter is being used. Recharge a battery indicating a low voltage. Determine the reason for the discharge. Alternating battery usage with dual batteries is important. Refer to the engine manufacturer's manual for additional information on care and maintenance of batteries.



Batteries produce hydrogen and oxygen gases when being charged. These explosive gases escape through the vent/fill caps and may form an explosive atmosphere around the battery if the ventilation is poor. This gas may remain around the battery for several hours after charging. Sparks or flames can ignite the gas and cause an explosion.



**Fire or Explosion Hazard!**

Only qualified personnel should install batteries and perform electrical system maintenance. Do not expose batteries to open flame or sparks. Do not smoke near batteries.



**Poison!**

Sulfuric acid in batteries can cause severe burns. Avoid contact with skin, eyes, or clothing. Wear goggles, rubber gloves and protective apron when working with batteries. In case of skin contact, flush with water at least 15 minutes. If swallowed, drink large quantities of water or milk. Follow with Milk of Magnesia, beaten egg or vegetable oil. Get medical attention immediately.



Disconnect the battery before working on electrical or ignition system to prevent electrical shock and accidental ignition.

**B. Electrical Wiring Maintenance**

Periodically, inspect all wiring for nicks, chaffing, embrittlement, improper support, etc. Spraying the electrical connections with an electrical connection cleaner will reduce corrosion and improve electrical continuity.



DO NOT allow corrosion to build up on connections. This can cause equipment to operate improperly.



The American Boat and Yacht Council (ABYC) has published a standard for the color coding of boat wiring. Four Winns voluntarily complies with these standards so the owner of the new boat can install new equipment or troubleshoot the electrical system. The following table summarizes the color code system

Wire Color	Wire Designation
Red	Wires on positive (+) side of battery that go to starter. This wire is non-protected.
Red/Purple Stripe	50 amp protected wire that runs from the engine to the fuse panel at the helm.
Yellow with Red Stripe	Wire from starter switch to starter solenoid.
Yellow	Power lead to bilge blower from a fuse or switch.
Dark Gray	Sensor wire from tachometer sender to tachometer.
Brown/Red	Leads to bilge pump from switch.
Brown/Orange	Leads to auto bilge pump.
Purple	Wire between ignition switch and coil. Wire from ignition switch through distribution panel to electrical instruments.
Orange	Accessories
Dark Blue	Wire from switch to instrument lights.
Light Blue	Sensor wire from engine oil pressure sender to oil pressure gauge.
Tan	Sensor wire from water temperature sender to water temperature gauge.
Pink	Sensor wire from fuel tank level sender to fuel gauge.
Purple/White	Trim position
White/Green	Trim down
White/Blue	Trim up
White/Red	Trim power
Black	Ground
Gray/Green	Bow light
Gray/Blue	Stern light

**Wiring Color Code**

Note: Some of these colors can serve more than one type of circuit.

**H - 7 STRAY CURRENT CORROSION**

**A. General**

Electrically induced underwater corrosion occasionally affects boats and their related components. This is referred to as “Stray Current Corrosion” and appears as surface pitting or deterioration. Stray current corrosion is the decomposition of chemical compounds by electric current.

Stray current corrosion can be caused by the polarity of the dockside wiring system of the boat being reversed from the power source (reversed polarity) or surrounding boats, an improperly wired battery installation, other boats that are in close proximity that have electrical power leakages, or any other source close to the boat that has electrical power leakage into the water. Stern drive units are especially vulnerable to stray current corrosion.

Periodically inspect the drive components and thru-hull fittings to determine if stray current corrosion damage exists. If corrosion damage is found, determine and correct the cause of stray current to prevent further damage. Consult an experienced marine electrician or contact your Four Winns dealer for assistance.

The use of some shore power battery chargers, while the boat is in the water and the battery is connected to the system, can cause stray current corrosion. Have an experienced marine electrician review any battery charger installation to ensure a stray current corrosion problem will not develop. An improper battery connection is a common cause of stray current corrosion.

**NOTICE**

Use only “Coast Guard” approved battery chargers. Consult your Four Winns dealer for his recommendations.

Corrosion is usually more prevalent in polluted or salt water than in clean water. It is also more likely to occur when dockage is in an area with steel piers, large metal boats, or where shore power is in use.



## **B. Galvanic Corrosion**

Galvanic corrosion results from a potential electrical difference existing between dissimilar metals immersed in a conductive solution (e.g., salt or brackish water). If these metals touch or are otherwise electrically connected, this potential difference produces an electron flow between them. The attack on the more active metal is usually increased and the attack on the less active metal is decreased, as compared to when these metals are not touching.

## **C. Corrosion Prevention**

Anti-corrosion anodes are attached to the bottom of the gimbal housing to prevent corrosion to your stern drive and underwater parts. These anodes will be slowly eroded away by galvanic action and require periodic inspection. Please refer to the section on “Anti-Corrosion Anodes” in your engine manufacturer’s manual for additional information. The engine manual is included in the owner’s packet.

# FUEL SYSTEMS

## I - 1 GASOLINE FUEL SYSTEMS

Gasoline fuel systems used in Four Winns® boats are designed to meet or exceed the requirements of the U.S. Coast Guard, the National Marine Manufacturers Association, and the American Boat and Yacht Council in effect at the time of manufacture.

Tanks on Four Winns® boats are located forward of the aft bilge compartment below the floor. Please see the Freedom™ or Horizon™ specifications included in your owner's packet for fuel tank capacities or visit our website at [www.fourwinns.com](http://www.fourwinns.com).

### NOTICE

Use only clean fuel of the type and grade recommended by the engine manufacturer. Engine damage resulting from the use of a lower octane gasoline is considered misuse of the engine and will void the engine warranty. Refer to the section on Gasoline Requirements in the engine manual for information on octane specifications.

### A. System Testing

All gasoline fuel systems have been factory inspected and pressure tested in accordance with regulations in effect at the time of manufacture. Additionally, each fuel tank must pass rigid tests and inspections performed by the fuel tank manufacturer.

Prior to taking delivery, it is important that a full inspection be made of the entire fuel system by the selling dealer. An entry on the Four Winns® Pre-Delivery Inspection Form portion of the Warranty Registration Card will attest to the dealer's performance of this service.

### B. Fuel Fills

Fuel fill deck plates are located either on the aft deck or side decks, and are marked "GAS". To open, insert the deck plate key into the holes on the cap and rotate counterclockwise. A bead chain connects the cap to body to help prevent loss overboard. Be sure to utilize the proper type and grade of fuel as recommended by the engine manufacturer. See Section I-3 for additional information.

The fuel fill fitting allows for venting below the fill cap. While the tank is being filled, the air displaced by the fuel escapes through the fuel fill/vent. This reduces the amount of fuel spillage. **Always** open the lid slowly to allow air to escape. See Figure I1.

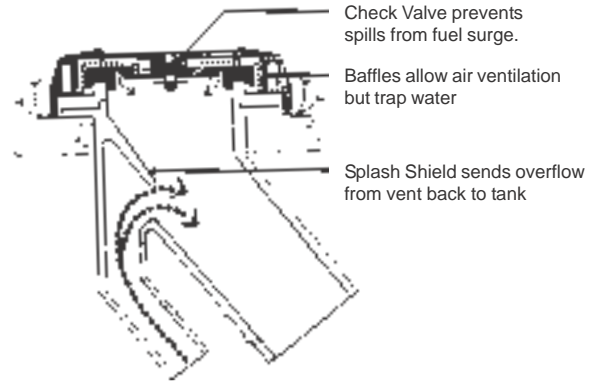

Figure I1: Fuel Fill

The gasket seal on the fuel fill cap assists in sealing when closed. A missing or damaged gasket can allow water on the surrounding surfaces to run into the tank. Periodically inspect the gasket and the fuel deck plate for damage.

### WARNING

DO NOT confuse GAS deck fill plate with WATER or WASTE deck plates. Deck fill plates are labeled according to the intended use.

### WARNING

Spilled fuel is a fire hazard. DO NOT overfill or overflow the tank, or allow fuel spills into the hull or bilge. If spillage occurs, clean up immediately and dispose of soiled rags/towels in a proper container.

### NOTICE

When fueling at a marina, DO NOT overfill. Fuel may spill into the water.

After fueling, replace the fill cap, and wash the areas around the fuel fill plate. Residual fuel left on the deck and hull sides can be dangerous, and will yellow the fiberglass. It will also damage the tape stripes and logos.

### C. Anti-Syphon Valves

The fuel withdrawal line is equipped with an anti-syphon valve where the line attaches to the fuel tank. This valve prevents gasoline from syphoning out of the fuel tank should a line rupture. See Figure I2 for anti-syphon location.

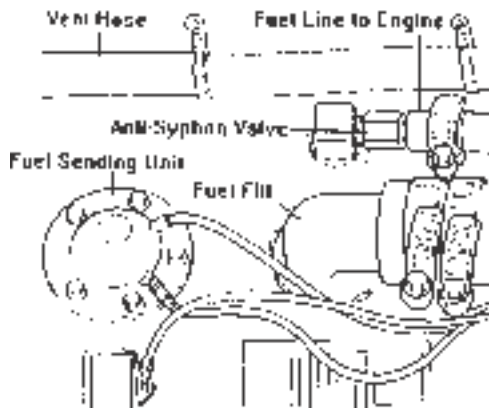

Figure I2: Fuel Tank Fittings

**CAUTION**

The fuel withdrawals are positioned in the fuel tanks to achieve optimum fuel usage, and fuel line routing. At certain speeds and hull trim angles, the fuel supply at the withdrawal tank location can increase or decrease accordingly. Be extremely careful when attempting to operate the boat on a minimum amount of fuel. Though some fuel may be in the tank, the relative trim angle of the boat may cause the fuel to flow away from the withdrawal.

**NOTICE**

Access plates or lids are provided in the floor for easier access to the fuel pick-up, anti-syphon valve and sender.

### D. Fuel Gauge

The fuel gauge indicates the amount of fuel in the tank. See Section E-7F - Fuel Gauge for additional information on fuel gauge use.

### E. Fuel Senders

The fuel sender consists of a float which travels up and down a stationary tube. The float measures the level of the fuel in the tank and sends a signal to the fuel gauge. See Figure I3.

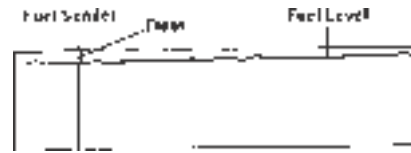

Figure I3: Fuel Sender Operation

Due to the mechanical nature of the fuel sender, variations in readings during various speeds of operation may occur. This system is merely a relative indication of the available fuel supply and not a calibrated instrument. With this type of sending unit a more accurate measurement of fuel level is obtained with the boat in a level position.

The gauge readings will also vary with the trim angle of the boat. When sitting at a dock and the boat is nearly level, the fuel gauge will register accurately. Refer to Figure I3. When boating, the trim angle of the boat changes and affects the gauge readings. Under these conditions, the fuel sender will register "full" for the first few hours of running time until the fuel level drops below the 3/4 or 1/2 mark. This is caused by the angle of the fuel in the tank as shown in Figure I4.

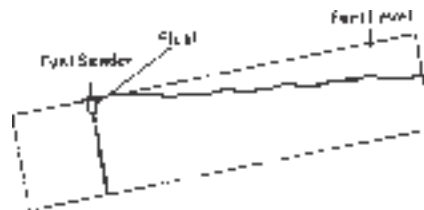

Figure I4: Effects of Trim Angle

It is very important to keep track of hours and fuel consumption to obtain an average gallon per hour consumption figure. Refer to the fuel log located at the back of this manual. This will prevent any problems with running out of fuel on the water.

Dealers are equipped with some general figures on consumption which can be used as a guide until specific information on your boat is determined. Because of boating conditions, speed, weight and other factors common to your situation, fuel consumption will vary between your boat and consumption figures developed by Four Winns.

When the fuel gauge begins to register below the "full" mark, the gauge readings will drop much faster until it reads "empty". When this occurs, the trim angle has affected the sender reading. When the gauge registers "empty", the sender has bottomed out and there may be 3 to 4 gallons of fuel in the tank. See Figure I5.

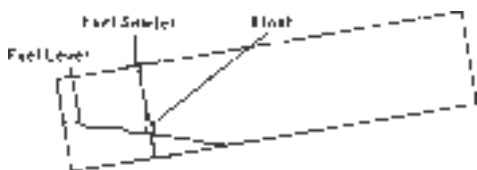

Figure I5: Trim Angle Effect with Low Fuel

**F. Fuel Filters**

Fuel filters are installed on each engine. Filters should be changed frequently to assure an adequate supply of fuel to the engine. Refer to the engine manual for additional information. The engine manual is included in the owner's information packet.

**NOTICE**

Canister-type filters should be changed annually.

**G. Use and Maintenance**

**WARNING**

DO NOT let the odor of gasoline go unchecked. If the odor of gasoline is noted, DO NOT START ENGINE. If engine is running, SHUT OFF ENGINE, ELECTRICAL AND HEAT GENERATING EQUIPMENT. Investigate and correct the situation immediately! Have all passengers put on personal flotation devices and keep fire extinguishers at hand until the situation is resolved.

**WARNING**

Avoid serious injury or death from fire or explosion resulting from leaking fuel. Inspect systems for leaks at least once a year.

**WARNING**

To help guard against damage, avoid the storage or handling of gear near the fuel lines, fittings and tanks.

The warning label below is placed in aft areas of outboard boats that are large enough to accommodate a six gallon portable fuel tank.

**WARNING**

No ventilation is provided. Fuel vapors are a fire and explosion hazard. To avoid injury or death **do not store** fuel or flammable liquids here.

**I - 2 FUEL STANDARDS**

Be cautious when using gasoline that contains alcohol. Refer to the section on gasoline requirements in your engine manual for additional information.

**CAUTION**

To conform to Federal Air Quality Standards, the petroleum industry reduced the amount of tetraethyl lead in gasoline. Alcohol is being blended with gasoline to help restore the octane rating lost when the lead was removed. While blending alcohol with gasoline increases the octane level of the fuel, it can also create certain safety and performance related problems for boaters.

**A. Problems With Alcohol In Gasoline**

Below is a list of problems which may be experienced when using blended gasoline.

1. Premature deterioration of fuel system components may occur. Alcohol will attack rubber fuel hoses, fuel tanks, fuel filters, fuel pumps and rubber gaskets. This deterioration will lead to fuel system leakage.
2. Phase separation of fuel will cause contamination. Water which accumulates in the tank through contamination or condensation will be absorbed by the alcohol. This water-heavy alcohol will settle at the bottom of the tank. This phase separation will lead to fuel tank corrosion. This may also result in a lean mixture to the carburetor and cause engine stalling or possible engine damage.

The use of alcohol additives in gasoline has become more widespread. Regulations on public notification of the existence of additives is currently controlled by the Environmental Protection Agency (EPA). Some states do require that gasoline pumps display information on additives (especially alcohol). If alcohol content is not posted, ask and avoid using fuel containing alcohol if possible.

**B. Recommendations**

Assume blended gasoline is being used and follow these recommendations below.

1. Inspect fuel hoses often. A deteriorated hose containing alcohol blended gasoline will normally be soft and swollen. A deteriorating hose containing no fuel will normally be hard and brittle. In both cases the hose should be replaced.
2. Ventilate the engine compartment before starting the engine(s). Operate the engine compartment blower for four (4) minutes. Then, prior to starting the engine(s), check the bilge area for the scent of gasoline fumes; DO NOT start the engine(s) if the odor of gasoline is detected.
3. Frequently inspect the fuel system fittings. Inspect the fuel tank, pump and filter for signs of leaks or corrosion. Visually inspect for deteriorating metal fittings at the fuel hose connections.

 **WARNING**

Avoid serious injury or death from fire or explosion resulting from leaking fuel. Inspect system for leaks at least once a year.

If areas are found within the fuel system that appear questionable, have a qualified marine technician inspect the system. A thorough fuel system examination should be made by an experienced marine technician at least once a year.

**I - 3 FUELING INSTRUCTIONS**

1. Avoid fueling at night except in emergencies.
2. When moored at fueling pier:
  - a. Do not smoke, strike matches, or throw switches.
  - b. Stop all engines, motors, fans, and devices that could produce sparks.

- c. Put out all lights.
3. Before starting to fuel:
  - a. Ensure that boat is moored securely.
  - b. Be sure the proper type and grade of fuel as recommended by your Engine Owners Manual is used.
  - c. Determine how much additional fuel is required to avoid overflow.

4. During fueling:

Keep the fill nozzle in contact with the fuel opening at all times to guard against possible static spark. See Figure I6.

 **WARNING**

Spilled fuel is a fire or explosion hazard. DO NOT overflow the tank or allow fuel spills into the hull or bilges. Avoid overboard spills. Visually monitor the fuel vent located on either the transom or side of the hull. When the tank is full, fuel will flow from the fuel vent.



Grounding the fuel hose - Proper  
(Nozzle in contact with fuel opening)

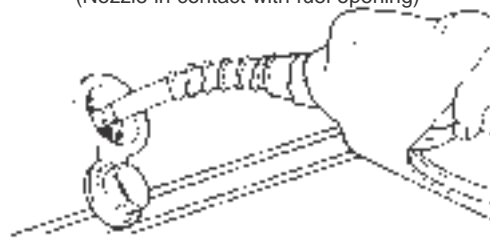

Not grounding the fuel hose - Improper  
(Nozzle not in contact with fuel opening)

**Figure I6: Grounding Fuel Hose**

5. After fueling:
  - a. Replace all fill caps securely.
  - b. Wipe up any spilled fuel.
  - c. Determine that there is no odor of gasoline in the engine compartment or below decks before starting machinery, turning on lights or lighting stove. Operate the bilge blower system for at least four (4) minutes before engine start-up.
  - d. Be prepared to cast off moorings as soon as engine is started.



# WASTE AND WATER SYSTEMS

## J - 1 GENERAL

Some Four Winns® models are equipped with a fresh water supply system. This system consists of a water supply tank, water distribution lines and a distribution pump. Refer to Figure J15 at the end of this section for general water system diagram. The water fill deck plate is located either on the aft deck or side decks, and is marked "WATER". The location of the water fill deck plate for the fresh water system may vary depending upon the model and optional equipment installed. See Figure J1.



Water Fill

Figure J1: Water Fill

### CAUTION

The water deck plate is appropriately labeled WATER. DO NOT fill the system with anything other than water. Should the system become contaminated with fuel or other toxic solution, complete system or component replacement may be necessary.

The water tank is equipped with an overboard vent. Maintain a close visual watch on the overboard vent while filling the water tank. Always fill the tank slowly. When the tank is almost full, water will spurt out of the vent.

### NOTICE

When filling the tank, never seal the hose to the deck plate. The tank would become pressurized and could rupture.

### NOTICE

DO NOT overfill the water tank. Tank damage may result. Water capacity and tank location may vary due to other equipment that may be installed on the boat.

For information concerning fresh water tank capacities, please refer to the specification sheet or visit our website at [www.fourwinns.com](http://www.fourwinns.com).

The materials from which the components of the water system are made may give the water supply a peculiar taste, especially when new. This condition is normal and can be reduced somewhat through the use of a water filter; such as that produced by PuriTec™. The taste should completely dissipate in time.

## J - 2 DISINFECTING THE FRESH WATER SYSTEM

### CAUTION

The fresh (potable) water system should be disinfected prior to initial use.

The water system should be disinfected before first use and at the beginning of each season. The following information is a general guide to disinfecting the fresh water system.

1. Flush the boat's water system thoroughly with fresh water. Make sure all non-toxic antifreeze is removed from the system.
2. The water system should be drained completely.
3. To disinfect the water system, use one gallon of water and 1/4 cup of Clorox® or Purex® household bleach (5% sodium hypochlorite solution). This is recommended for each 15 gallons of tank capacity.
4. Allow to stand for three (3) hours. If time is a factor, greater concentrations of chlorine solution will be needed to disinfect the water system.
5. Drain the system.

6. Flush the system thoroughly with fresh water.
7. Fill the system with fresh water.

To remove excessive chlorine taste or odor which might remain in the system, prepare a solution of one quart vinegar to five gallons water and allow this solution to agitate in the tank for several days during boating. Then drain tank and refill with fresh water.

The cockpit sinks are equipped with traps, and the water will drain slowly. If the system is not operating properly, have it checked by your authorized Four Winns dealer.

### J - 3 FRESH WATER SYSTEMS

#### A. Head Sink

Certain models have a sink placed in the enclosed head compartment. Water will be drawn when the switch is operated. See Figure J2. The switch to operate the fresh water system is located on the starboard helm and is marked FRESH WATER. After the tank has been filled, operate the pump switch until water comes out of the faucet. After all the air has been purged from the system and a steady flow of water is coming from the faucet, turn off the pump.



**Figure J2: Head Sink (Specific Models Only)**

**NOTICE**

If the line is routed improperly, kinked or is dislocated, the water pump may not operate properly. Inspect and correct the hose routing (if necessary). If a problem still exists, contact your Four Winns dealer for assistance.

**NOTICE**

DO NOT operate the pump with an empty tank. Damage to the water pump may result. Be sure the pump switch is off when not in use.

#### B. Cockpit Refreshment Center

Certain models come equipped with a refreshment center located inside the cockpit. The refreshment center includes common features such as a trash receptacle, sink with pressurized water system and Corian® counter top. Other features, on certain specified models only, include 110 volt ground fault current interrupter receptacle, refrigerator, drink holders and dual batteries. The switch to operate the fresh water system is located on the refreshment center or starboard helm and is marked FRESH WATER. The same fresh water pump is utilized by both the head sink, cockpit sink, and transom washdown. See Figure J3.



**Figure J3: Typical Refreshment Centers**

### C. Transom Washdown

The transom washdown is available on certain models. The washdown unit is typically located on the starboard side of the transom. The water supply system can be used for showering or washdown purposes at the transom. The switch to operate the water pump is located on the refreshment center or starboard helm and is marked FRESH WATER. See Figure J4.



Figure J4: Transom Shower

The fresh water tank which supplies water to the transom washdown is usually located in the rear engine compartment on the port side of the boat. Other specific models have the fresh water tank located on the starboard side. The fresh water fill deck plate is usually located on the same side as the tank. The fresh water deck fills are clearly mark "WATER".

A separate toggle switch to operate the pump is located at the helm or refreshment center and is wired directly to the battery. An in-line fuse is included to protect the water pump. The pump is located in the rear engine compartment usually near the vicinity of the fresh water tank.

Models equipped with the transom washdown option will use the same fresh water pump used for the cockpit sink. With the "FRESH WATER" switch "ON", push the spray nozzle button to purge any air that may be in the system. When a steady flow of water is coming from the washdown nozzle the air has been purged. Release the spray nozzle when finished. As the pressure builds, the pump will automatically shut off at 35 psi.

When properly primed and activated, the pressurized water system can be used in the same manner as the water system in a home. An automatic pressure sensor in the water pump keeps the system pressurized. Simply operate the spray nozzle and water will be delivered. If the system has been recently filled, or has not been used for an extended period of time, air bubbles may accumulate at the pump. If this should happen, re-priming may be necessary.

### J - 4 HEADS

#### A. Enclosed Heads

On certain models, a fully enclosed fiberglass head is a standard feature built into the port console. These roomy heads offer an opening port light with screen, fiberglass liner, and overhead lighting. Depending on the model, a porta potti or Vacu-flush® toilet is available. Also found in certain models with enclosed heads is a sink with pressurized water, 110 volt receptacle, storage locker, tissue holder and removable carpet. See Figure J2. Refer to the manufacturer's literature included in the owner's packet regarding the use, care and maintenance of the various toilets used.

#### B. Porta Potti

##### Preparation:

Separate unit by sliding the locking lever to the left "unlocked" position and hold (Figure J5-A). Separate the units (Figure J5-B).



Figure J5 (A & B): Separate Porta Potti

With the waste tank (lower section) sitting flat, open valve by pulling handle out (Figure J6-A).

Add deodorant through the valve opening (Figure J6-B). Use Thetford Holding Tank Deodorant (sample included) in built-in storage compartment (Figure J6-C).

Add water to cover tank bottom. Close valve and replace deodorant (Figure J6-D).



Figure J6 (A - D): Porta Potti Preparation

Recombine the unit. Align hinge with front interlocking tabs. To secure unit, press downward...it should click into place.

Fill fresh water tank by removing the water fill cap and filling the tank with fresh water (Figure J7). **(NEVER add holding tank chemical to the fresh water tank assembly.)** Replace and tighten the cap securely.



Figure J7: Filling Fresh Water Tank

**NOTICE**

**Before each use:** With seat cover closed, open and close the holding tank valve (Figure J8) to vent any pressure that may have built up as a result of heat or altitude. This prevents upward splashing of bowl contents when toilet is flushed.

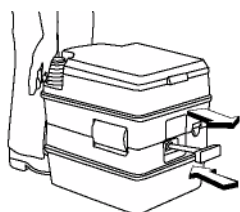

Figure J8: Porta Potti - Bellows Flush Operation

**Bellows Flush Operation:**

1. Pull out holding tank valve handle (Figure J8).
2. Push down on bellows to rinse the bowl.
3. Push valve handle all the way in to insure an odor-tight seal.

**Emptying of Portable Models:**

1. Empty when waste holding tank level appears full. **DO NOT ALLOW THE TANK TO BECOME OVERFILLED.**
2. Make sure waste valve handle is in the closed position.
3. Remove fresh water tank from waste holding tank (Figure J9).



Figure J9: Removing Fresh Water Tank

4. Remove waste holding tank from hold down brackets.
5. Carry the waste holding tank to any permanent toilet facility. Rotate the pour-out spout to the desired position. Remove the cap. Depress the air relief valve with your thumb while emptying (Figure J10).



Figure J10: Emptying Waste Holding Tank

6. Rinse waste holding tank and recharge as described under Preparation portion of this section.
7. Reassemble unit and fasten to floor or deck.

**C. Vacu-flush® Sanitation System - (Specific Models Only)**

The Vacu-flush® sanitation system eliminates the unpleasant sulfide odors which plague saltwater systems. Flush water is no longer drawn through the through-hull fittings, seacock, and vented loop. It also extends the life of the system components by eliminating salt water and impurities from accumulating in the system over time.

The Vacu-flush® toilet operates in a different way from other marine toilets. Vacu-flush® systems use a small amount of water (a little more than a pint) per flush in addition to a simple vacuum. The toilet is connected to the fresh water system. Fresh water is the key to an odor free bathroom compartment. Vacu-flush® toilets are equipped with an intergrade vacuum breaker which prevents the possible contamination of the potable/fresh water supply. See Figures J11 & J12. Also refer to the manufacturer's literature included in the owner's packet.



**NOTICE**

The Vacu-Flush switch located in the head must be ON in order for the toilet to flush & recharge.

To operate:

1. To add water to the toilet before using, raise flush lever until desired water level is reached. Generally, more water is required only when flushing solids. See Figure J11.
2. To flush toilet, press flush lever sharply down to the floor until contents clear bowl. A sharp popping noise is normal when the vacuum seal is broken and the flushing action begins. **Be sure to hold lever down for 3 seconds.** If flush lever is accidentally released before waste clears bowl, do not attempt to flush toilet again until vacuum pump stops running. A small amount of water should remain in the bowl after flushing.
3. Do not dispose of sanitary napkins or other non-dissolving items in toilet, such as facial tissue or paper towels. These items can cause plugging of the system. Refer to the "Deodorants and Special Tissue" section in the manufacturer's manual for more information.

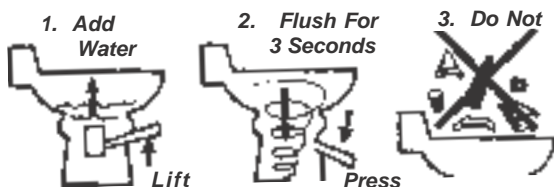

Figure J11: Vacu-flush™ Operations

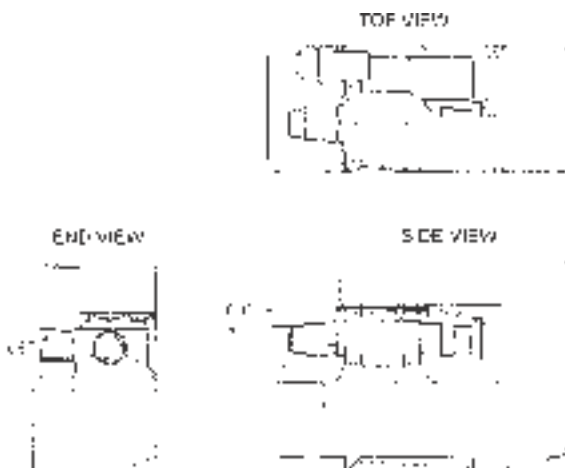

Figure J12: Vacu-flush™ Vacuum Generator

**D. Head Pump Out**

The waste holding tank should be emptied when waste holding tank level gauge indicator on the porta potti (models with pumpout option only) has changed from green to red (Figure J13) or when the waste level indicator for the Vacu-flush system reads almost full. **DO NOT ALLOW THE TANK TO BECOME OVERFILLED.**



Figure J13: Porta Potti

If equipped with the head pump out, the waste can be removed from the tank at a pumping station. A deck plate fitting labeled WASTE, is provided for this purpose. Most marina fueling facilities provide service for waste pump out. For waste holding capacities, please refer to the specification sheet, manufacturer's literature and/or our website.

To pump out the holding tank:

1. Connect the dockside pump out connection to the WASTE plate located on the deck.

**NOTICE**

Usually the dockside pump out connection will screw into the waste deck plate or has a rubber sleeve that inserts into the plate and must be held in position during the pump out operation.

2. Have the pumping station operator activate the pumping equipment. The waste will be drawn from the holding tank and into the pumping stations disposal tank.
3. Remove the pump out connection from the deck plate. Add 1 gallon of clean water to the holding tank through the waste deck fitting using a dockside water hose.
4. Repeat steps 1 & 2 above to pump out the water used in step 3 to flush the holding tank.
5. Add waste holding tank treatment chemical available from the dockside pumping station operator to the head. Flush at least twice.

**CAUTION**

Be careful when handling and storing treatment chemicals. Not only are they toxic, but they will also stain and damage surrounding surface.

It will be necessary to remove the top holding tank of the portable head to fill with water. Refer to the manufacturer's literature included in the owner's packet regarding the use, care and maintenance of the porta potti.

**J - 5 GRAY WATER SYSTEM - OPTIONAL**

The gray water system is optional on certain models only. The water from the galley sink and head sink drains into a holding tank. The waste level indicator is located in the head compartment. A pumpout fitting labeled WASTE but designated for gray water is provided on the starboard side of the deck. The gray water tank is located in the engine compartment, center aft. See the specification sheet or our website for capacity.

**NOTICE**

Certain geographical areas have restrictions on grey water being pumped or drained overboard. Be sure to check all local, state and federal laws in the boating area.

**J - 6 LIVEWELL**

An aft livewell is available on models with Fish & Ski package options. The livewell has a capacity of approximately 7 gallons and comes equipped with an aerator pump which is operated from a switch on the dash. The water is aerated as it is pumped into the tank. A hatch is included for access and the tailpiece regulates the water level. To drain, remove the tailpiece as shown in Figure J14.

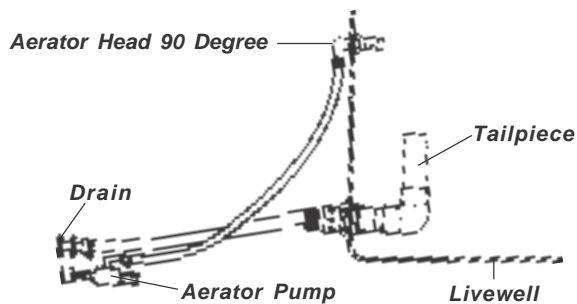

Figure J14: Fish & Ski Livewell

Be sure the batteries in the boat are properly charged. Operating the pressure pump from a battery with a low charge will result in pump cycling. This could lead to premature pump failure.

**NOTICE**

Failure to keep the livewell tank vent fitting clean will cause excessive pressure buildup within the tank during filling. This can cause water tank damage.

Winter lay-up service procedures should include a thorough draining of the livewell system. Disconnect all accessible fittings. Blow out all lines. Be sure the livewell tubs, aerator pump, and lines are completely dry. Freezing water can cause severe damage to all water system components.

**J - 7 SYSTEM MAINTENANCE**

Be sure the batteries in the boat are properly charged. Operating the pressure pump from a battery with a low charge will result in pump cycling. This could lead to premature pump failure.

**WARNING**

The decomposition of waste produces a colorless, odorless gas, methane, that is lighter than air, combustible, and extremely lethal. Always provide sufficient ventilation when effecting repairs to the waste system and allow no odor from the waste system to go unresolved.

**A. Clean Vents and Screens**

Periodically, inspect the water tank vents and thru-hull vent fittings for any dirt, wax, etc. Carefully remove any obstruction with a pipe cleaner or similar device. **Be sure not to puncture any screens.** The stainless steel vent cap is not removable.

**NOTICE**

Failure to keep the water tank vent fitting clean will cause excessive pressure buildup within the tank during filling. This can cause water tank damage.



## B. Winterizing the Water System

Winter lay-up service procedures should include a thorough draining of the water system. Disconnect all accessible fittings. Blow out all lines. Be sure the water tank, waste tank, pumps and lines are completely dry. Freezing water can cause severe damage to all water system components.

### NOTICE

It may be necessary to disconnect the hose below the faucet to remove excess water in the lines to prevent freeze damage.

### NOTICE

Always winterize the fresh water system prior to winterization of the hull drainage (bilge pump) system.

Draining the system as mentioned can be very tedious and an incomplete job can result in expensive repairs. The use of nontoxic antifreeze (such as R.V. antifreeze) designed for fresh water systems considerably reduces the work necessary and is a more positive means of winterizing the system. Follow the directions included with the antifreeze solution.

To winterize:

1. Turn on the water pump/faucet and drain the water tank. The water tanks on some models can be drained by removing the withdrawal hose from the tank and allowing water to drain into the bilge.

### NOTICE

DO NOT run the water pump without water in the system. Pump damage can result. Be watchful and turn the pump off as soon as the tank becomes empty.

2. Add 1/2 gallon of R.V. non-toxic antifreeze to the water tank.
3. Turn ON the pump until undiluted antifreeze is seen.



Use only nontoxic antifreeze solutions such as R.V. antifreeze. DO NOT use ethylene glycol solutions; the type that is used in engine coolant systems. These are toxic.

### NOTICE

Be sure to wipe up any antifreeze that has been spilled on the fiberglass surfaces to prevent possible discoloration or damage to the gel coat.

Depending upon options and model, additional information by the equipment manufacturers is included in the owner's packet. Also, refer to Section R for Maintenance.

# WATER SYSTEM

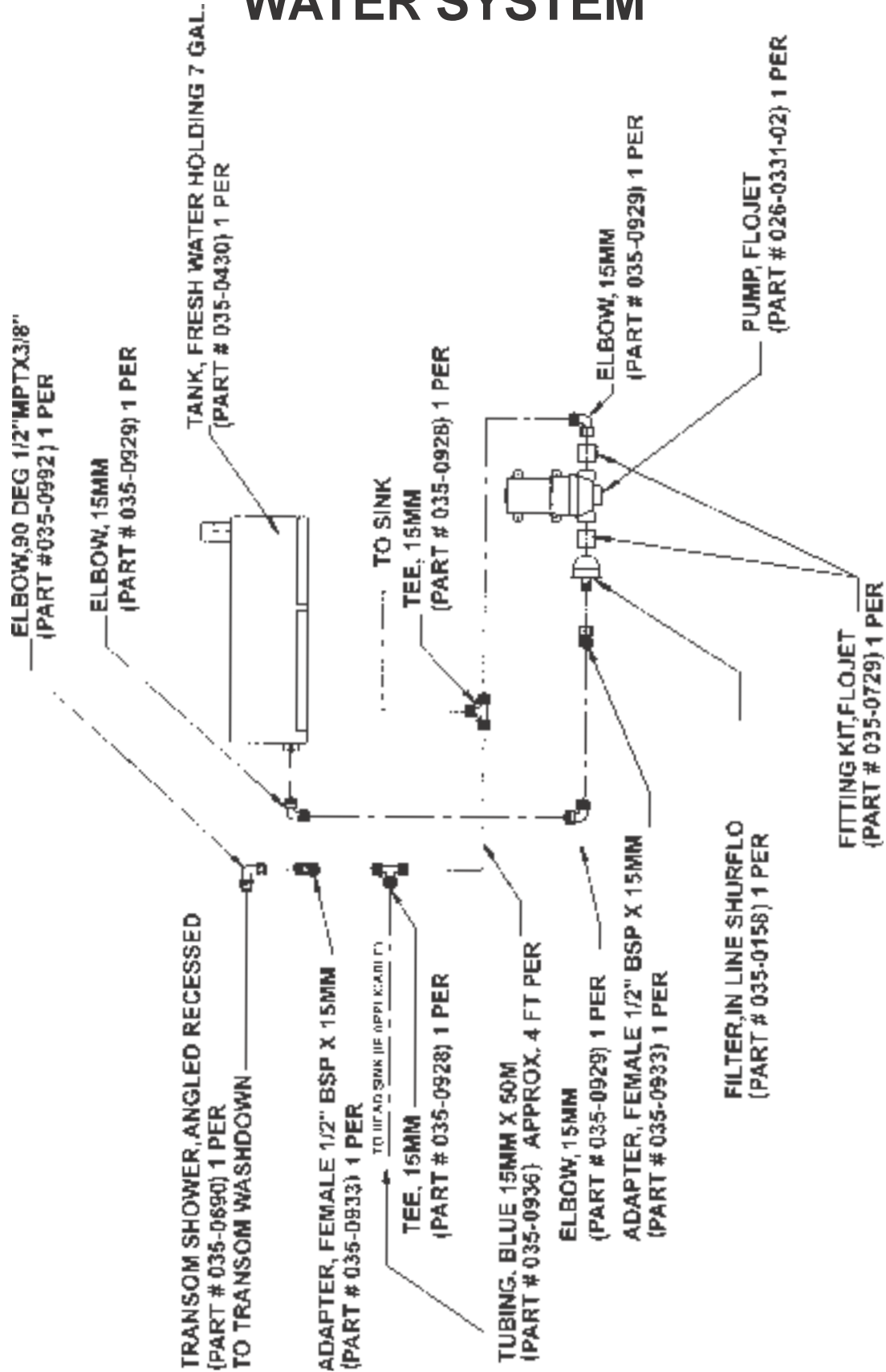

Figure J15: General Water System Diagram

# VENTILATION & DRAINAGE SYSTEMS

## K - 1 ENGINE COMPARTMENT VENTILATION

All Four Winns® stern drive models are equipped with engine compartment ventilation. This system is designed to meet or exceed the requirements (in effect at the time of manufacture) of the U.S. Coast Guard, the National Marine Manufacturers Association, and the American Boat and Yacht Council.

### A. Gravity Ventilation System

This system includes air intake and exhaust components. The exhaust ducting reaches to the lower bilge area. This provides adequate air movement while underway and during bilge blower operation.

### B. Forced Air Ventilation

All Four Winns® models except outboards are equipped with an electric bilge blower. The bilge blower provides the ventilation required prior to starting the engines and while at idle. See Section H - Electrical Systems for blower operation instructions.



#### WARNING

Gasoline vapors can explode resulting in injury or death. Before starting the engine, check the engine compartment bilge for gasoline or vapors, and operate blower for four (4) minutes, and verify blower operation. Run blower when vessel is operating below cruising speed. ALWAYS operate the bilge blower while the engines are at idle.

### C. Engine Ventilation System Maintenance

Periodic inspection and cleaning of the ventilation ducts is necessary to ensure adequate air circulation. A buildup of leaves, twigs, or other debris can severely reduce ventilation. Be sure bilge water does not accumulate to a level that would obstruct the ventilation ducts.

Blower operation can be tested by placing a hand over the vents. DO NOT rely on the sound of the blower. Be sure a substantial amount of air is being exhausted by the bilge blower. Check the bilge blower system often, preferably before each cruise.

Should blower noise and vibration be excessive, loosening the bilge blower mounting screws and then tightening evenly usually reduces noise considerably.

## K - 2 HULL DRAINAGE SYSTEMS

### A. Transom Drain

A transom drain with plug is provided in the engine compartment to allow water drainage. When the boat is out of the water, the boat and trailer should be positioned so any bilge water accumulation during dry storage will flow towards the transom.



#### CAUTION

Be sure the drain plug is securely in place prior to launching the boat. Upon shipment of the boat, the drain plug is usually taped to the steering wheel.

### B. Bilge Pumps

Bilge pumps are provided in the bottom of the hull to remove miscellaneous water accumulations that might occur during normal boating or weather conditions. The bilge pump is controlled by the bilge pump switch on the dash panel. See Section H-3 for a detailed description of the bilge pump switches.

Bilge pumps equipped with automatic switches are standard on all Freedom™ and Horizon™ models. As the water level rises, the automatic float switch will activate the pump.

When leaving the boat unattended for long periods of time or during excessive rain storms, it is a good idea to check on the boat for excessive water accumulation. Be sure both the bilge pump and automatic float switch are operating properly. The operating time of the bilge pump will be limited to the battery capacity.

**NOTICE**

While at rest, any bilge water accumulation may flow forward. Therefore, operate the bilge pump shortly after getting underway and while the boat is at a substantial running angle. **DO NOT** allow bilge water to accumulate. Damage to the engine or other components may result.

Periodically, clean the bilge pump strainers. **DO NOT** allow dirt and debris to clog the bilge pump intakes. Check operation of the bilge pump float switch often to ensure movement of the switch is not restricted by debris, portions of the hull, etc.

Wipe up any oil accumulation in the bilge prior to activation of the bilge pump. Pumping oil overboard will pollute the water, and is subject to fine.

After winterization of the fresh water systems, be sure the bilge area, bilge pump and associated hoses are thoroughly dry. Damage to the hull, bilge pump and other equipment could occur if water is allowed to freeze in the bilge.

**C. Liner Drains**

Fiberglass liners are typically standard on most Freedom™ and Horizon™ models. Liner drains are provided on these models with fiberglass liners. Fiberglass liners can be cleaned easily by hosing the floor. The water will drain into the bilge and be pumped overboard by the bilge pump.

**D. Bilge Compartment Drainage**

Certain bulkhead areas of Four Winns® boats are sealed in accordance with U.S. Coast Guard regulations effective at the date of manufacture. Drainage is provided and water can be removed with the bilge pump.

# INTERIOR EQUIPMENT

## L - 1 COCKPIT REFRESHMENT CENTER

Certain Horizon™ models come equipped with a refreshment center located in the cockpit either on the port or starboard side depending upon which model you have. The refreshment center includes a trash receptacle, sink with pressurized water system, Corian™ counter top and drink holders. Additional features on certain Horizons™ may include 110 volt ground fault current interrupter receptacle, refrigerator, and dual batteries. Features listed may be subject to change without notice. See Figure L1.

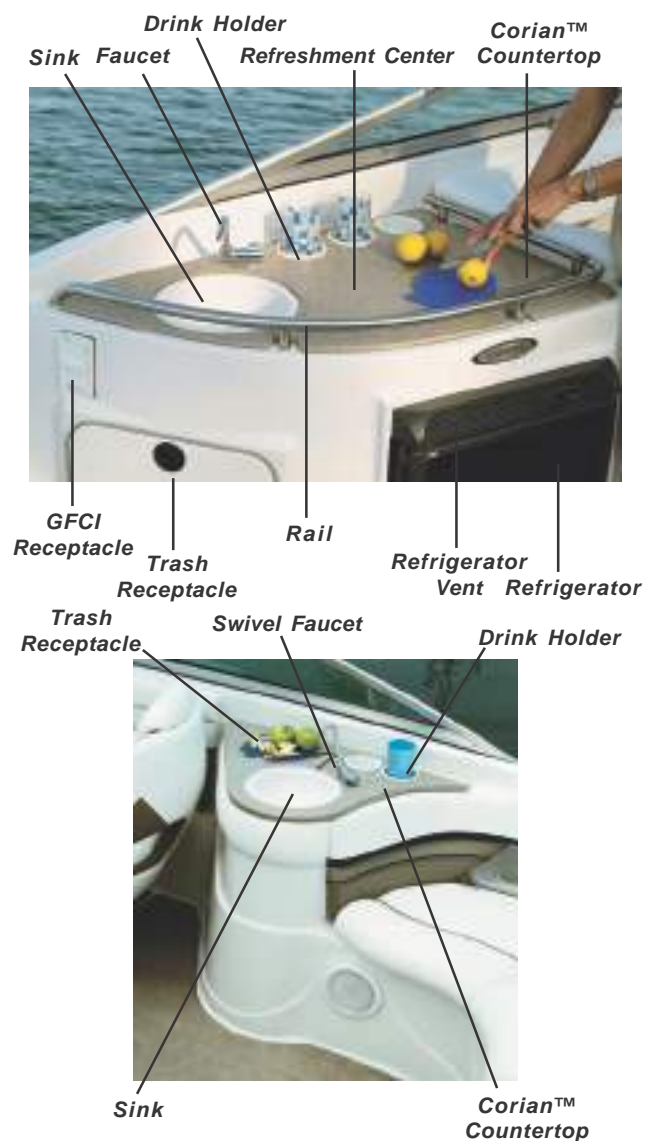

Figure L1: Refreshment Centers

## L - 2 GLOVEBOX OR STORAGE COMPARTMENT

A glovebox or a storage compartment is available on many for these models and is usually built into the port console. It allows for storage of valuables under lock and key. See Figure L2.



Figure L2: Port Helm Glovebox & Storage Compartment

## L - 3 IN-DASH COOLER

Some models are equipped with an in-dash cooler for storage of soft drinks. The excess water from melting ice drains overboard. See Figure L3.



Figure L3: In-Dash Cooler



#### L - 4 REMOVABLE COOLER

A 36-quart “carry-on” cooler is available on some models. The removable cooler stows beneath the U-wrap or C-wrap lounge hinged seat in the cockpit. See Figure L4.



Figure L4: 36-Quart “Carry-On” Cooler

#### L - 5 HEADS

On certain Horizon™ models, a fully enclosed fiberglass head is a standard feature built into the port console. These roomy heads offer an opening port light with screen, fiberglass liner, and overhead lighting. Depending on the model, a porta potti or Vacu-flush® toilet is available. Also found in certain models with enclosed heads is a sink with pressurized water, 110 volt receptacle, storage locker, tissue holder and removable carpet. See Figure L5. Refer to Section J-4 and the manufacturer’s literature included in the owner’s packet regarding the use, care and maintenance of the various toilets used.



Figure L5: Horizon™ Enclosed Head

#### L - 6 STEREO

Four Winns offers a CD stereo as standard equipment on the Freedom and Horizon™ models. The stereo may include a remote display at the helm depending on the model. An optional stereo remote may be installed at the swim platform on certain models.

Generally, the stereo is mounted either on the starboard helm or port console. On some models the stereo is concealed in the glovebox for added security and protection. The stereo’s microprocessor is coated to help protect it from the elements. The stereo’s faceplate is water resistant and the quick release door has a water-tight seal. For stereo operation, please refer to the manufacturer’s manual included in the owner’s information packet.

The speakers are installed within the side bulkheads or seat bases.

For additional information on stereos, refer to Section H-3C of this manual and the manufacturer’s literature included in the owner’s packet.

#### L - 7 BURLWOOD HELM ENHANCEMENTS

A standard feature on the Freedom and Horizon™ models is the burlwood wood grain accent. This consists of finished synthetic burlwood mahogany for the instrument, switch and ignition panel. For care and upkeep information, refer to Section Q-3 - Burlwood Mahogany in this manual.

#### L - 8 ANCHOR STORAGE OR ANCHOR LOCKER

Certain Freedom and Horizon™ models have either storage for an anchor under the bow seat or have built into the bow an anchor locker. Some models have a hidden telescoping ladder also located inside the anchor locker for boarding at the bow.

To access the anchor locker simply lift the anchor lid using the pull handle. Certain models have a notch in the lid allowing the anchor line to pass through while the anchor lid is closed. See Figure L6. The anchor locker has an overboard drain to remove any water that might otherwise accumulate. The compartment should be inspected after each use and kept clean of dirt and debris to prevent plugging of the drain hole. For information on anchors, refer to Section M-5.



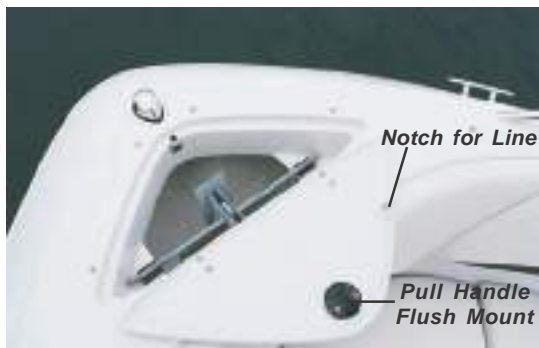

Figure L6: Anchor Locker

**L - 9 SKI STORAGE LOCKER**

A standard feature on the Freedom and Horizon™ models is a ski storage locker. The ski storage locker is usually located in the cockpit floor, between the driver and passenger seats. The locker allows for storage of skis, knee boards, tow ropes, personal floatation devices, etc. The ski storage lid is hinged and may include a gas assist shock for ease of use. See Figure L7.



Figure L7: In-Floor Ski Locker

**L - 10 AFT DECK STORAGE LOCKER(S) & SUNDECK COMPARTMENTS**

Certain Horizon™ models have storage locker(s) located at the transom. Access may be gained from the swim platform area. Depending on which style of flush pull used, you may open the locker by either lifting the flush mounted pull handles or you may have to first rotate the pull handle 180 degrees and then lift. See Figure L8.



Figure L8: Aft Storage Lockers

Additional storage compartments on certain models are located beneath the sundeck pads. See Figure L9.

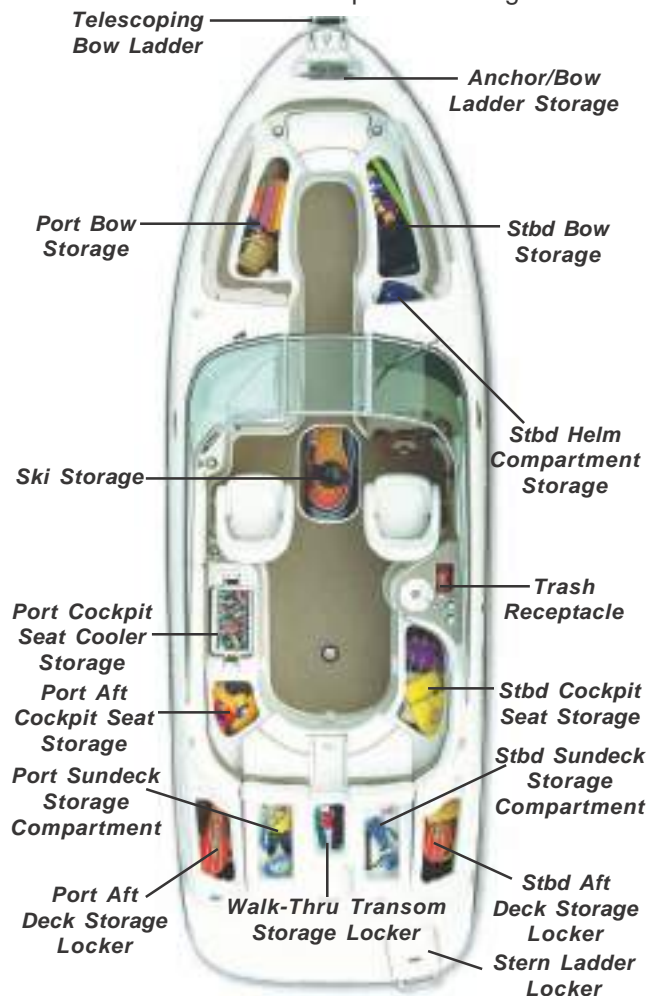

Figure L9: Storage Locations - Example View Only  
 Note: Quantity, locations, size & availability of storage compartments/lockers & equipment vary from model to model and is subject to change without notice.

### L - 11 BOW STORAGE

Underneath the port and starboard bow cushion is additional storage for all types of gear. The port and starboard bow seat cushions are hinged on many of the models. See Figure L10. On other models the port & starboard cushions may be removed for storage access. Additionally, a bow storage compartment is located in the floor on certain larger models.



Figure L10: Bow Storage

### L - 12 HELM STORAGE

Helm storage is available on certain models. Depending on the model, access may be gained either by lifting up on the hinged starboard bow backrest or by opening the walk-thru storage locker door. A gas assist shock is used to hold the backrest cushion in the raised position while accessing the helm console locker. See Figures L11 and L12. Note: Some models may include a port console storage locker. Access to the port console locker is identical to the starboard console locker.



Figure L11: Starboard Helm Console Storage

Walk-Thru Storage Door



Figure L12: Walk-Thru Helm Console Storage

### L - 13 BOW FILL-IN CUSHIONS

With the optional bow fill-in cushion(s) available on most models you can turn the bow into a sundeck. See Figure L13. These bow fill-in cushions can be easily removed or installed in a matter of minutes. Depending on the model, the bow fill-in cushions may be stored in the various storage areas of the boat or underneath the starboard helm or port consoles. Please contact your Four Winns dealer regarding inquiries about this option.

Bow Fill-In Cushion - Forward    Bow Fill-In Cushion - Aft



Figure L13: Bow Fill-In Cushions

**L - 14 WALK-THRU DOOR**

An optional walk-thru door is available on many of the open bow models. The walk-thru doors are designed to keep out the wind and weather, making for a warmer cockpit area. See Figure L14. Follow the cleaning directions for plexiglass described in Section Q-6 - Acrylic Plastic - (Plexiglass). Please see your Four Winns dealer for information and availability.



*Figure L14: Walk-Thru Door*

**L - 15 AFT FILL-IN CUSHIONS (U-WRAP or C-WRAP)**

Available on certain models with a U-wrap or C-wrap seating configurations are optional aft fill-in cushions. Just like the bow fill-in cushions, you can turn your stern into a sundeck or berthing space. These aft fill-in cushions can be easily removed or installed in a matter of minutes. Please check with your Four Winns dealer for availability and other additional information with regard to this option. See Figure L15.

*Aft Fill-In Cushion*



*Figure L15: Aft Fill-In Cushion - C-Wrap Seating*

**L-16 ADDITIONAL COCKPIT STORAGE**

Additional storage is available under the aft seat cushions on certain models with U-wrap and C-wrap seating configurations. See Figure L9. Storage and cooler access can be gained by lifting up the various cushions. Use of both hands when lifting up on a cushion will make for an easier operation. On certain models only, quick inspection access to the engine compartment can be gained by lifting up and out on the center cockpit cushion.

**L-17 PORT SETTEE LOUNGER - (Certain Models Only)**

The settee lounge not only provides a comfortable and elegant seating arrangement but offers additional storage space underneath. To gain access to the storage below, lift up on the settee cushion and pull out. See Figure L16.

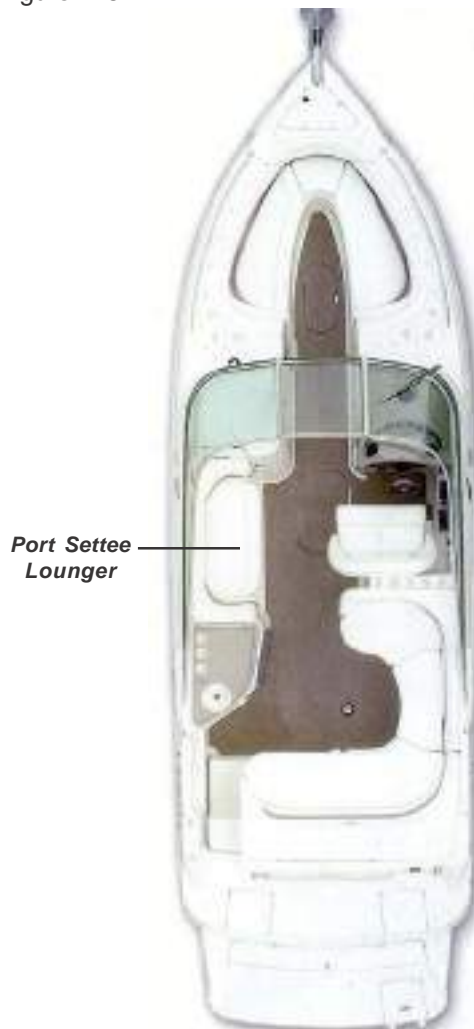

*Figure L16: Port Settee Lounger*



**L-18 INTEGRATED TACKLE BOX & LIVEWELL - (FISH & SKI STERN DRIVES)**

As an added convenience, an integrated tackle box is located on the starboard side of the transom decking of the stern drive Fish & Ski models. Built into the port transom decking is a livewell with circulating pump and overboard drain, perfect to keep your catch or store live bait. See Figures L17 and L18.



*Figure L17: Integrated Tackle Box*



*Figure L18: Integrated Livewell*

**L - 19 COCKPIT TABLES**

An optional aft cockpit table with a flush mount is available on certain models. See Figure L19. Rotating the table top while lifting will ease the removal of the table from the leg. Table legs are removable for easy storage by unscrewing or unlocking the leg from the flush mounted floor base.



*Figure L19: Aft Cockpit Table*

# EXTERIOR EQUIPMENT

## M - 1 RAILS & DECK HARDWARE

### A. Rails

Grab handles have been installed to provide security for passengers in the cockpit. Limiting passenger movement while underway is recommended. All those on board should be safely seated whenever possible. Additional care must be taken when in rough seas or foul weather.

The rail system and hardware fittings have been selected and installed to perform specific functions. Fenders or mooring lines should not be secured to the rails or stanchions. Be certain that a clear lead exists when running dock lines or an anchor line. A line inadvertently threaded around a stanchion or over the rail could cause damage.

### B. Cleats

The cleats that have been installed are specifically designed and are intended to be used as mooring cleats. Their purpose is for securing the vessel to a dock, pier, mooring, or anchor.

An optional pull-up style cleat is available on certain models. The pull-up cleat gives your boat a more sleek style. When you desire to use the cleat, simply pull up on the cleat. When finished with the cleat, push in and the cleat will remain in its retracted position until the next time you desire to use it. See Figures M1 and M2. Please consult your Four Winns dealer for details.



Figure M1: Pull-Up Cleat - Extended



Figure M2: Pull-Up Cleat - Retracted



**WARNING**

Four Winns® Boats are not equipped with any hardware designed for towing purposes. The mooring cleats that are installed on the boat are not to be used for towing another vessel or having the boat towed. Refer to Section A - Operation for additional precautions regarding grounding and towing.

### C. Transom Ski Tow Ring

The transom ski tow ring or in some cases a stern rail with ski eye, is mounted on the transom above the extended swim platform. All Freedom and Horizon™ models should be able to tow two skiers under normal boating conditions. However, Four Winns recommends no more than two skiers be pulled behind the boat at any time.



**WARNING**

Do not use ski tow fitting for lifting or parasailing. Fitting could pull out of deck resulting in serious injury or death.



**WARNING**

To prevent personal injury or damage to the boat, DO NOT tow more than two water skiers with the transom mounted ski tow ring.

**NOTICE**

Skier's weight, boating conditions, amount of gear, and operator's experience will affect the number of skiers which can be pulled.



### D. Stainless Steel Package Option

Available on certain models is an optional stainless steel package which includes a bow scuff plate, pull-up cleats and docking lights. The bow scuff plate adds extra protection for your hull and the docking lights will make docking your boat easier during periods of reduced visibility. See Figure M3.

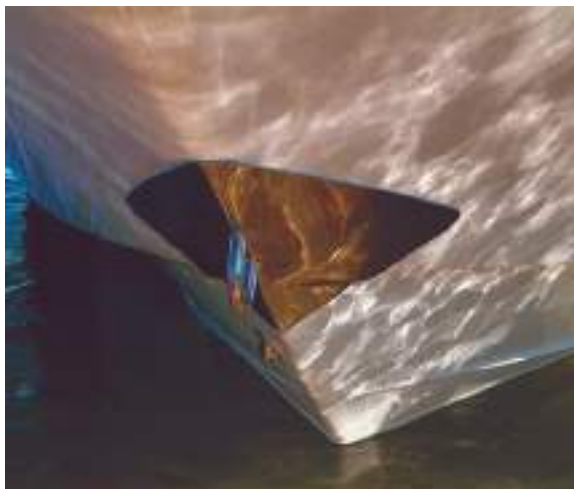

Figure M3: Bow Scuff Plate

### E. Maintenance

The majority of the hardware installed is made of stainless steel. Regardless of the type of hardware used, periodic maintenance is necessary.

The manufacturer of our hardware recommends the following when washing your boat:

1. Rinse the hardware with fresh water after each exposure to saltwater.
2. Periodically wash the hardware with mild soap, warm water, and a sponge. Then dry it with a soft cloth.
3. Avoid cleaners, abrasives, waxes, and most of all, **do not use steel wool.**

**NOTICE**

All fittings must be periodically inspected for loosening, wear, and damage. Problems should be corrected immediately!

### M - 2 WINDSHIELDS

A windshield is standard equipment. Windshields consisting of tempered safety glass and the windshield frame consists of a painted or polished aluminum. For easy accessibility to and from the bow, a walk-thru center windshield is standard. Stainless steel supports or braces are used in all of the windshield assemblies. See Figure M4.



Figure M4: Windshield

**CAUTION**

We recommend you close and secure the walk-thru windshield while underway. Damage to the windshield could result.

**CAUTION**

Secure windshield with strap when in open position. Securing the walk-thru windshield will help prevent the windshield from accidentally slamming closed due to high wind and/or wake condition, thus reducing the chance of damage to windshield or injury.

Most of our Fish & Ski models come equipped with removable side windshield wings. See Figure M5. Removing these side windshield wings allows you to drop a line over the boat's side. The removable windshield wings should be placed in the accompanying storage bag and stowed away for safe keeping.

To remove the windshield wing, simply remove the pin with lanyard and gently slide the wing up, out of the track.

To install, reverse the process. Slide the wing onto the track and insert the pin with lanyard through the deck hinge and windshield wing.



**Figure M5: Fish & Ski Removable Windshield Wing**

Windshields made of tempered glass can be cleaned with automotive glass cleaners or dishwashing soap and water. Ensure that a clean cloth is used to prevent scratching the glass.

Aluminum can be cleaned with similar products or with nonabrasive cleaners such as Fantastik™.

**NOTICE**

Read the label before using any product. DO NOT use abrasive cleaners.

**M - 3 EXTENDED SWIM PLATFORM - LADDER**

Four Winns provides an extended fiberglass swim platform on certain Freedom and Horizon™ models. See Figure M6. The extended platform is either integrated into the deck or extends the existing swim platform by mounting to the hull to create more space for water sport activities. The extended swim platform has a skid-resistant surface and may include a self-draining storage tub. The swim platform is also recessed for the ladder and a hinging ladder lid is provided. With this design, the ladder is concealed and you do not lose valuable platform space. In addition, a hand hold has been placed in the ladder lid to assist in boarding.



**Figure M6: Extended Swim Platform**

The ladder is “deep” and “angled” mounted which makes it easier to climb. Its starboard location means you’re not approaching a down skier on your “blind side”. See Figure M7.



**Figure M7: Stern Boarding Ladder**

 **WARNING**

Keep hands and fingers away from ladder hinges to prevent injury.



**WARNING**

Never approach or use ladder when the motor is running. Severe injury or death will result from contact with rotating propeller.



**WARNING**

Shut off motor when near swimmers. Severe injury or death will result from contact with rotating propeller.



**WARNING**

To prevent personal injury, swim platform and transom entry area must not be occupied while engine(s) are running and/or boat is underway.

**NOTICE**

Always secure the ladder before boating. Damage to the ladder may otherwise result.

**M - 4 COCKPIT AFT FILL-IN BACKREST (DOOR)**

A cockpit aft fill-in backrest (door) and aft fill-in cushion are removable to allow walk-thru access from the swim platform to the cockpit. The backrest and cushion are available on certain models only. To secure the aft fill-in backrest (door) to the transom, simply slide the backrest's L-brackets onto the support cleats and push down into place. To prevent a possible man overboard situation, make sure the swim platform area is unoccupied and the cockpit aft fill-in backrest (door) is in place before each cruise. See Figure M8.



*Figure M8: Transom Walk-Thru Backrest Door*



**WARNING**

Prevent falls overboard. Secure transom walk-thru backrest and stay inside cockpit while underway.



**WARNING**

To prevent personal injury, swim platform must not be occupied and transom walk-thru backrest door must be in place while engines are running.



**CAUTION**

To prevent personal injury, DO NOT sit on the transom walk-thru backrest door.

**M - 5 ANCHOR & ANCHORING**

Anchors are available in different shapes, sizes and weights to fit different boats, uses, and conditions. The weight of the anchor and diameter of anchor line should be governed by the size and weight of your boat. Four Winns recommends a "Danforth style" 8-pound, Attwood<sup>®</sup> "Penetrating" anchor, with a 3/8" line be used on most the Freedom and Horizon<sup>™</sup> models. The recommended line length is 100-150 feet. Larger Horizon<sup>™</sup> models (28 feet or larger) require the 13-pound Attwood<sup>®</sup> "Penetrating" anchor, with a 1/2" line. The recommended line length is 150-300 feet. A Horizon<sup>™</sup> equipped with the windlass option (certain models only) receives a 14-pound Delta Fast Set<sup>™</sup> by Simpson Lawrence<sup>®</sup> with 150 feet of rope and chain. Because of differences in style, a larger anchor may be needed for different bottom or boating conditions. Your Four Winns dealer can tell you which anchor will work best for your boat.

Keep anchor secure while underway to prevent damage or injury due to sudden shifting in the boat's attitude.

Use two or more anchors if anchoring overnight or for extended periods. If not using two anchors, make certain there is sufficient clearance for your boat to swing in a full circle to prevent damage in case of shifting winds.

Make certain you have enough anchor line (or scope) for the depth of water. Your anchor line should be 6 to 7 times the depth of water anchored in. For example, if you are in 20 feet of water, use 120 to 140 feet of anchor line.

 **CAUTION**

Secure anchor line to bow eye or deck cleat. Never tie anchor line to a rail, rail fitting or other hardware not designed to support this stress.

To drop anchor:

Approach your selected anchoring site from downwind and come to a dead stop over the spot where you want to drop anchor. Lower the anchor. Lower the anchor.

Maneuver the boat slowly backwards until length of anchor line is 6 or 7 times the depth of the water.

Fasten the anchor line around the bow eye or deck cleat. Anchor flukes should dig in and catch. Watch for anchor drag by checking shoreline landmarks at the time the anchor is dropped and one-half hour later. If the boat has drifted away from these reference marks, the anchor is dragging and must be reset.

To weigh anchor:

Start the engine running before pulling in anchor.

Slowly maneuver the boat forward to reduce tension on the line and make retrieval of the anchor line easier.

Raise and secure the anchor.

 **WARNING**

**Always be sure to raise and secure the anchor prior to operating your boat.** Failure to raise and secure anchor before getting underway could result in severe injury or damage to boat from rebounding anchor.

If the anchor becomes stuck, attach the vertical line to the mooring cleat. Wave action on the bow may lift flukes from the bottom and free the anchor. If the anchor is still stuck, feed out a few feet of line and attach it to the bow cleat. Maneuver the boat around the anchor, keeping the line firm. Determine the angle that will work to pull the anchor free.

Anchors are usually a dealer installed option. Please check with your Four Winns dealer for recommendations.

**M - 6 BOW ROLLER**

The bow roller assembly is standard equipment on select Horizon™ models only. The bow roller extends beyond the bow and is integrated with the anchor chute. The function of the bow roller is to allow easier retrieval of the anchor. It also protects the hull/deck from surface abrasions or gouges while either anchored or when retrieving the anchor. Refer to Figure M9. Refer to manufacturer's literature for operation, care and maintenance included in the owner's packet.

 **WARNING**

To prevent a possible man overboard situation, NEVER stand on, or try to utilize the bow platform area in any way while the boat is underway.



Figure M9: Bow Roller

**M - 7 WINDLASS OPTION - (Specific Models Only)**

The windlass is optional on certain Horizon™ models. A windlass is an electrically controlled winch mechanism utilized in conjunction with the bow roller for the retrieval of the anchor. The mechanical winch portion is mounted inside the anchor locker. The windlass can be controlled by either a set of switches mounted on the helm console or by the foot pedals at the anchor locker. See Figure M10. The windlass option also comes with a rope, chain, and anchor. Refer to the manufacturer's literature included in the owner's packet for operating instructions. Please contact your Four Winns dealer for more information.



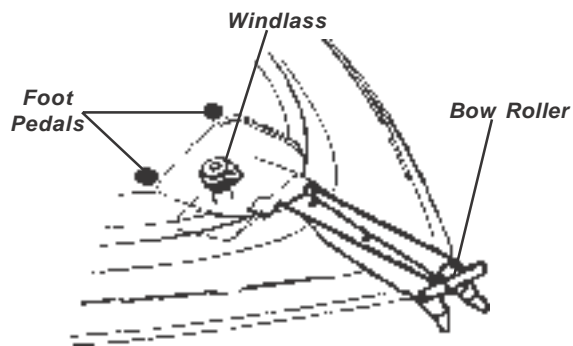

Figure M10: Windlass



Always utilize the chain stop provided with the windlass/bow roller combination. The chain stop prevents the anchor from accidentally releasing while the boat is moving thus preventing damage to the boat or possible injury or death to individual(s) aboard the boat. See Figure M11.

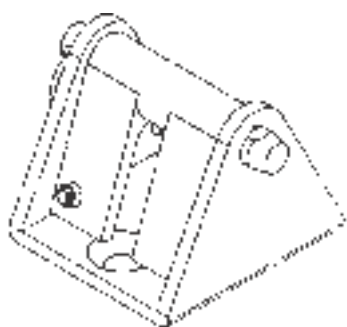

Figure M11: Chain Stop

### M - 8 DOCKING LIGHTS

Certain specific Horizon™ models are available with optional docking lights. Equipped with these lights, docking your boat becomes easier during periods of reduced visibility. Please see your Four Winns dealer for information and availability. See Figure M12.



Figure M12: Docking Light

### M - 9 THRU-HULL EXHAUST

Available on certain specified models only is an optional thru-hull exhaust system. With a flick of the helm mounted control switch the exhaust system changes from standard operation to a full throaty rumble. Another flick of the switch returns the exhaust system back to standard exhaust. See Figure M13. For inquiries regarding the thru-hull exhaust option, please contact your Four Winns dealer.



Figure M13: Thru-Hull Exhaust

#### NOTICE

Always be aware of local laws on noise limits. Noise means engine noise, radio noise or even yelling by people on your boat. Good seamanship demands that you operate your boat quietly so as not to infringe on the rights of others. Do not use thru-hull exhaust unless you are well offshore.



**M - 10 WAKEBOARD TOWER - Certain Models Only**

Certain Horizon® models have an optional wakeboard tower available. See Figure M14. The towers come with a variety of features which will sure to please the wakeboard enthusiasts. Please see your Four Winns dealer for information regarding this option. Refer to Section B-4 - Water Sports of this manual for safety guidelines.



*Figure M14: Wakeboard Tower*



Do not use ski tow fitting or wakeboard tower for lifting or parasailing. Fittings could pull out of deck resulting in serious injury or death.

# UPHOLSTERY

## N - 1 SEATING

### A. Bow Seating

Bow seating is provided on the sportboat models. Certain bow cushions have hinges or are removable to allow for access to storage areas below. See Figure N1.



*Figure N1: Hinged Bow Cushion*

Bow fill-in cushions are optional. When installed, the fill-in cushions help form a berth across the bow area. These cushions may be stored below the port and starboard consoles or in head compartment if applicable.

### B. Loungers

The back-to-back loungers may be available on certain Freedom™ and Horizon™ models. These loungers may either be adjustable or non-adjustable depending on the model. The loungers consist of two major components. These components are the lounge backrest and the lounge seat cushion. The lounge has been designed so that each component is serviceable. See Figure N2.



*Figure N2: Lounger - Seat Position*

The lounge will extend into a reclining position. See Figure N3. A headrest brace on each end will allow for a “kickup” headrest to be created when in the reclining (lounge) position on certain models. Refer to Figures N41, N42 & N43 at the end of this section for additional information on lounge operation.



*Figure N3: Back-to-Back Lounger - Reclining Position*

#### CAUTION

Do not sit on the headrest when in elevated headrest position. The headrest brace may become damaged, break or suddenly give way causing loss of balance and possible injury.

#### NOTICE

Do not sit on the very end of lounge when placed in the “reclining” position. Excessive force on ends of the loungers can bend the track and/or hinges, not allowing proper operation.

In addition, the “adjustable” lounge is adjustable forward and back. To adjust, typically rotate the forward handle and push/pull the seat assembly. The total travel distance or adjustment is approximately six (6) inches.

### C. Aft Fill-In Seating

For certain boats having a U-shaped seating and C-shaped seating configurations, optional aft fill-in cushions may be available. You can turn your stern into a sundeck or berthing space. These aft fill-in cushions can be easily removed or installed in a matter of minutes. See Figure N4. Please see your Four Winns dealer for details.



Figure N4: Aft Fill-In Cushions

### D. Bucket Seats

Adjustable bucket seat(s) are available on most of the seating configurations for Freedom™ and Horizon™ models. See Figure N5.



Figure N5: Bucket Seat with Flip-Up Bolster

To adjust, lift up on the seat adjustment lever under the seat. Slide the seat forward or aft to the desired position. The seat will adjust approximately six (6) inches. See Figure N6.



Lift adjustment lever up to move forward and back.

Figure N6: Bucket Seat Slider

The driver's side bucket seat and the port side bucket seat (if applicable) can swivel and face toward the stern of the boat. When pulling a water skier, this permits the spotter to be in the proper position to observe. Depending upon which model you have, the bucket seat(s) may be limited in the amount and direction of swivel possible.

The bucket seat generally comes standard with flip-up bolster. By simply flipping up the bolster the driver is able to sit higher in the seat. This is designed to give the driver greater flexibility, increased visibility, and riding comfort. See Figure N5.

**NOTICE**

The bucket seats may or may not rotate completely 180°. The amount and direction of swivel available depends on the model you have.

**NOTICE**

When rotating the bucket seat, damage to seat, steering wheel (if applicable), and/or coaming pad may result if attempting to rotate in the wrong direction or over-rotating. **DO NOT USE FORCE** to rotate the chair.

To rotate the bucket seat to face the aft position:

1. Tilt the steering wheel (if applicable) as far forward as possible.
2. Slide the seat completely forward or rearward (as needed to clear coaming/side pad or seat cushion) by using the lever located underneath the seat. See Figure N6.
3. Locate the lever on the right side of the bucket slider mechanism and lift upward to release the pin from the pedestal. This will allow you to rotate the seat. See Figure N7.

4. Rotate the bucket seat inboard (towards the center of the boat) until it faces as far aft as possible or desired. Once in position, push down on locking lever to lock seat in position. See Figure N8.

**WARNING**  
After rotating, lock seat in place securely. Sudden acceleration with seat unlocked could cause loss of balance and possible injury.

*Pull lever to up position to rotate seat.*



**Figure N7: Swivel Position**

*Once in desired position push lever down to lock seat in place.*



**Figure N8: Locking Position**

To return the bucket seat to the bow facing position:

1. Slide the seat completely forward or rearward (as needed to clear coaming/side pad or seat cushion) by using the lever located underneath the seat. See Figure N6.
2. Locate the lever on the right side of the bucket slider mechanism and lift upward to release the pin from the pedestal. This will allow you to rotate the seat. See Figure N7.
3. Rotate the bucket seat inboard until it is in the forward facing position. Once in position, push down on locking lever to lock seat in position. See Figure N8. In addition, DO NOT USE FORCE to rotate the chair.

4. Position the seat forward or aft according to the needs of the individual by using the lever located underneath the seat. See Figure N6.
5. Tilt the steering wheel (if applicable) to the desired position using the tilt lever knob on the steering column.

**WARNING**  
DO NOT sit on the backrest portion of any cockpit seat. The operator could lose control of boat or passengers could be thrown from boat. Also, the seat may be damaged from improper use.

### E. Double-Wide Helm Seat

On certain Horizon™ models, a standard double-wide helm seat with a flip-up bolster is standard. To adjust the helm seat push out on the locking lever under the seat, on the right. Slide the seat forward or aft to the desired position. The seat will adjust approximately six (6) inches. This helm seat does not swivel.

### F. Stern (Jump) Seats

On certain standard interiors, the motorhood and two jumpseats are installed at the stern. The jumpseats, in the lower positions are supported by the motor hood base and ski rack (lower upholstered pad) and/or liner. Only on certain models can the jumpseat be placed in an upper position to create a sunpad.

To install the jumpseats in the upper position (if applicable):

1. Remove the jumpseat from the lower position.
2. Place the cleat of the jumpseat into the upper recessed portion of the motorhood.
3. Push opposite end of the jumpseat into position. The fit should be snug and relatively flush with motorhood pad.

**CAUTION**  
To prevent personal injury, be sure the jump seats are secure before use. Do not step or walk on jumpseats. Jumpseats could move and cause loss of balance.

**NOTICE**

Do not operate the boat with jumpseats in their upper positions. Loss of cushions may occur due to cushions being blown overboard.

**NOTICE**

When traveling at highway speeds, be sure the jumpseats are secure (locked in their down positions). **Do not** tow your boat with the jumpseats in their sundeck position. Air currents (created within the interior when traveling) will lift the cushions up and out of the boat under certain conditions; especially when semi-trucks or other large vehicles pass by.

**G. Outboard Stern Seating**

Standard outboard seating is available on the Freedom™/Horizon models. On our outboard models the jumpseats can not be placed into a sundeck position.

**H. Fish & Ski Seating**

On Fish & Ski models the twin stern seats convert in seconds to pedestal fishing chairs. The fishing chair locations are one in the bow area and one in the stern.

To turn the stern seat into a fishing chair:

1. Place the fishing chair pedestal into the floor mount. Be sure the latch locks into place.
2. Remove the stern seat by lifting the seat up and out.
3. Place the stem of the stern seat onto the pedestal.

To turn the fishing chair into a stern seat reverse the procedure explained in the proceeding steps. To remove the pedestal, push on the release button and lift up.

**WARNING**

Failure to lock the fishing chair pedestal in place could result in injury. Be sure the pedestal is securely locked into place.

**WARNING**

DO NOT sit on the backrest portion of any cockpit seat. The helmsman could lose control of the boat or passengers could be thrown from the boat. The seat could also be damaged if excessive force is applied.

**WARNING**

To avoid possibility of occupant being thrown from boat, NEVER ALLOW ANYONE TO OCCUPY AN ELEVATED FISHING CHAIR WHEN THE BOAT IS UNDERWAY AT MORE THAN TROLLING SPEED.

**I. Stern Drive Fish & Ski Aft Seating**

On our stern drive Fish & Ski models the twin stern seats convert to pedestal fishing chairs in the same manner as the outboard models described earlier. Note: If Fish & Ski seat is installed and you want to gain access to the engine compartment, you will want to first remove the Fish & Ski seat along with the pedestal.

Access to the engine lid may be gained by unsnapping and removing the sundeck pad. Removal of the center stern seat cushion is also advisable when accessing the engine or using the stern fishing chair (less wear & tear). You can remove the center stern seat cushion by undoing the snaps. Additionally, when the center stern cushion is removed, a storage compartment may be found underneath the now exposed carpeted support board. Simply remove the carpeted support board for access by grasping the strap. Note: The carpeted support board must be installed prior to installing the center stern seat cushion. See Figure N9.

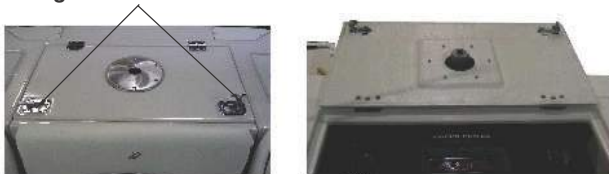

Figure N9: Stern Drive Fish & Ski - Stern Area



Locate the latches of the engine hatch. Lift up on the handle portion of the latches and rotate approximately 90 degrees. Rotation of latches will most likely be in opposite directions. After rotating latches, lift up using the handles of the latches. In some models, a gas shock is installed to assist with the lifting and holding the engine lid open while inspection or routine maintenance is being conducted. See Figure N10.

**Engine Hatch Latches**

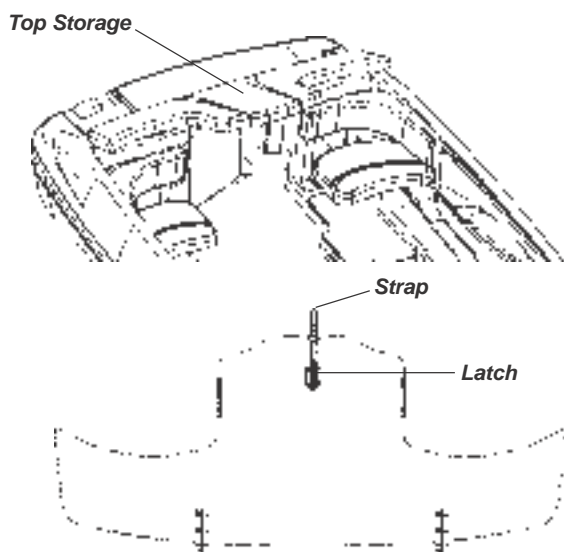

**Figure N10: Stern Drive Fish & Ski Engine Hatch**

To close the lid, carefully pull down on the engine lid. Grasp the handle portion of the latches and gently lower the engine into its closed position. Rotate latches to the locking positions and lower the handles into their flush, recessed positions.

**J. Top Storage**

The top storage compartment at the stern of the boat has storage compartments located underneath but does not allow for storage of the convertible canvas top assembly as the name would indicate. The top storage is secured by a latch mechanism. A gas shock keeps the top storage in the raised position while storing gear or for maintaining the engine. See Figure N11.



**Figure N11: Top Storage**

To open the top storage compartment :

Locate the strap and pull to release the latch.

Lift upward, assisting the gas shock, in opening the top storage cushion. Once gas shock is fully extended it will keep the top storage in the raised position.

To close the top storage compartment :

With both hands placed on the top storage cushion, lower the top storage gently into the closed position. Place both hands on top of the cushion directly over the latch mechanism and push down to ensure the latch engages the striker.

**K. Sundeck (SunSport Seating Option)**

The sundeck is typically a one piece cushion that runs the entire width (beam) of the boat at the stern. See Figure N10. The sundeck can be used for sunbathing and is supported by the engine bulkhead and other supports. Gas shocks or hydraulic supports assist in raising the sundeck and keeps the sundeck in the raised position while storing gear or for maintaining the engine. The sundeck is secured by either a latch-striker type or a rubber ball and socket-type closures. See Figure N13 and N14.



**Figure N12: SunSport & SunSport Lounge Seat**

To lift the sundeck using latch/striker type closure:

Locate the strap and pull to release the latch.

Using your other hand lift upward to assist the gas shock in opening the sundeck cushion. Once gas shock is

fully extended it will keep the sundeck in the raised position.

To close the sundeck:

With both hands placed on the sundeck cushion, lower the top storage gently into the closed position. Place both hands on top of the cushion directly over the latch mechanism and push down to ensure the latch engages the striker.



Figure N13: Sundeck Latch

To lift the sundeck using ball and socket type closures:

Place either one or both hands underneath the cushion and lift up.

To close the sundeck:

Lower the sundeck(s) gently into the closed position. Place both hands on top of the cushion directly over the "hold-down" assembly and push down to ensure the sundeck is secured.

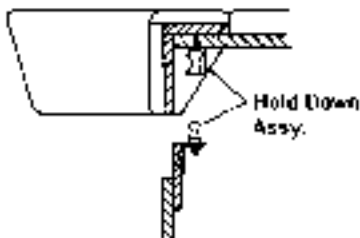

Figure N14: Hold-Down Assembly

## L. Sunsport Lounge Seat

The lounge assembly is part of the optional sunsport seating package. On most sunsport models the lounge seat slides out to create additional sunbathing space. A shock cord is attached to the lounge cushion and a bungie knob is placed on the support base. Looping the shock cord around the knob will prevent the lounge seat from accidentally sliding out when running in choppy water.

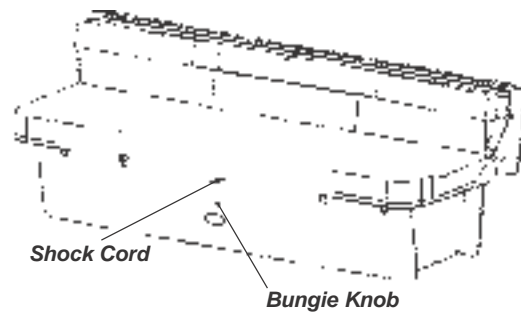

Figure N15: Pullout Lounge Assembly

To extend the lounge seat follow these steps:

1. Undo any shock cord(s) (bungie) from the knobs if applicable. These cords are located in the middle under the lounge seat.
2. While facing the lounge seat, place both hands underneath the seat and lift slightly.
3. Pull the lounge towards you and the seat will slide into position.

To raise the lounge seat to its upright position follow the next set of steps:

1. Facing the lounge seat, pull the strap on the backrest towards you.
2. With the other hand slightly raise up and push the lounge seat away from you, until it will no longer go any further.
3. Lower the lounge seat down and be sure it locks into position.
4. To be sure the lounge seat is locked into its upright position pull the lounge seat towards you. **DO NOT LIFT.** The lounge seat should not move forward.
5. Secure the shock cords around the knobs on the seat base assembly. See Figure N15.

### NOTICE

Never operate your boat with the sundeck, top storage or motorhood in their open positions. Doing so could result in damage or loss of cushion and hardware. This is also true when trailering your boat. **Cushions, if not properly stored and secure, will blow out of the boat.**

### M. Engine Cover (Motorhood)

For those models equipped with a hinged motorhood, access to the engine compartment may be gained readily by releasing the latch and lifting up on the handle until the engine cover is in the fully opened position. A cable restraints is installed to prevent the motorhood from opening beyond a certain point. To close the engine cover, take hold of the handle and gently lower the cover to the closed position. Apply slight downward pressure on the handle to ensure the engine cover latches securely. Lift up slightly on the motorhood handle (without releasing the motorhood latch) as a double-check. See Figure N16.

 **CAUTION**

When closing the engine cover, **do not** allow the motorhood to “slam” shut. Allowing the motorhood to “slam” shut can damage the fiberglass, hardware and/or cause bodily injury.

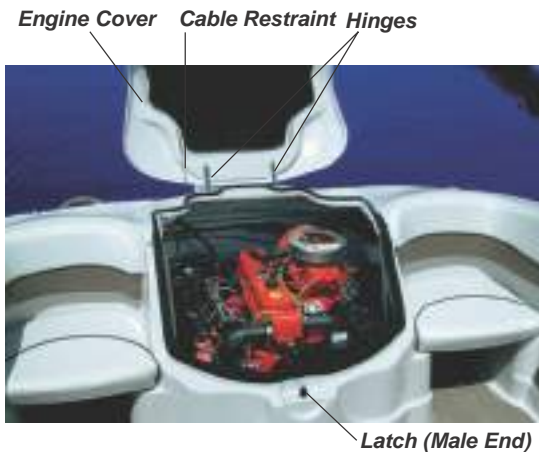

Figure N16: Engine Cover (Hinged Style)

For those models equipped with a removable motorhood, access to the engine compartment may be gained by releasing the draw latches located on each side of the engine cover. To access the draw latches removal of the jumpseats are necessary. See Figure N17. Quick engine inspection may be gained by lifting up on the strap of the motorhood cushion.



Port & Stbd Draw Style Latches

Figure N17: Engine Cover (Removable)

### N. Engine Hatch with Electric Lift (Screw Jack)

Certain models feature a motorhood or engine hatch with electric screw jack(s). The screw jack(s) lifts and lowers the engine hatch by pressing the switch located on the dash. The screw jack(s) runs off the boat’s battery. The prop rod should **always** be utilized to help support the weight to the engine hatch and to provide added safety while working on the engine(s). See Figure N18.

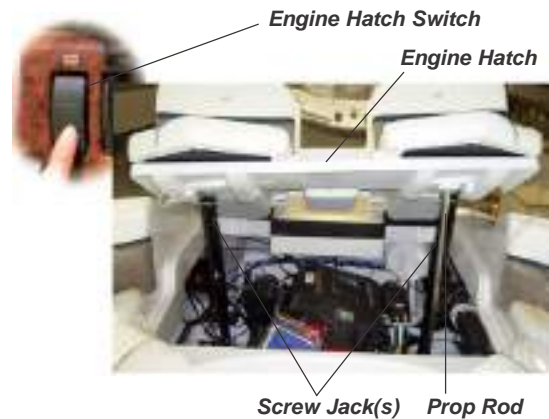

Figure N18: Electric Engine Hood Lift  
(Representative View Only - Actual Models May Vary)

To raise the engine hatch:

1. Remove the backrest walk-thru door and the walk-thru fill-in cushion (if applicable).
2. Press the engine hatch switch or manually raise the engine hood to its open position.

**CAUTION**

The engine hatch can be lifted without the screw jack(s). Use care and proper lifting techniques to prevent possible back injury. Prop rod must be properly placed to keep engine hatch in open position when lifting manually.

- Place the prop rod into the prop rod holders in the hatch and lower the hatch so the prop rod supports the hatch. Note: Ensure you lower the screw jack(s) to allow the engine hatch to rest on the rod.

**CAUTION**

Always use the engine hatch's prop rod when working on the engine. This provides added safety while helping to prolong the life of the screw jack(s) and engine hatch.

**NOTICE**

Never operate or trailer your boat with the engine hatch in its open position. Doing so could result in damage to the engine hatch, hardware, and/or loss of cushions.

To lower the engine hatch:

- Raise the hatch slightly and remove the prop rod from its holder.
- Press the engine hatch switch or manually lower the engine hatch to its closed position. If closing the engine hatch manually, gently lower it to the deck. Do not allow it to just drop to the deck.
- Replace and secure the backrest walk-thru door and the walk-thru fill-in cushion (if applicable).

**CAUTION**

If closing the engine hatch manually, **do not** allow the engine hatch to "slam" shut. Allowing the engine hatch to "slam" shut can damage the fiberglass and/or cause bodily injury.

**NOTICE**

Cushions, if not properly stored and secured, can blow out of the boat.

**O. U-Wrap Lounger Seating**

U-wrap (shaped) seating is found in certain Horizon™ models. A large amount of storage space is located under the removable seat cushion. These Horizon™ models usually have a 36-quart removable cooler located under the hinged seat cushion. See Figures N19, N20 & N21.

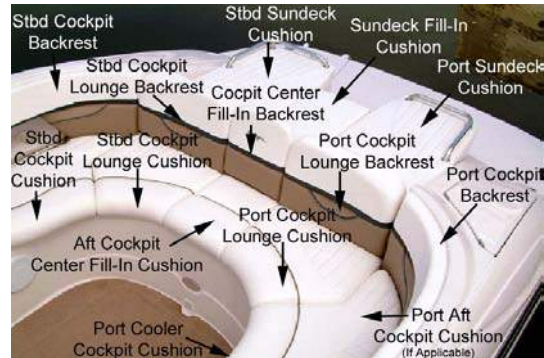

**Figure N19: U-Wrap Aft Seating**

Note: Representative View - Seating may vary depending upon model.



**Figure N20: Underseat Storage**

Removable Cooler



**Figure N21: 36-Quart Cooler Storage**



### P. Cockpit Aft Fill-In Backrest (Door)

The cockpit aft fill-in backrest (door) and aft fill-in walk-thru cushion are available on certain models only. A backrest and cushion are removable to allow walk-thru access from the swim platform to the cockpit. See Figure N22. To secure the aft fill-in backrest (door) to the transom, simply slide the backrest's L-brackets onto the support cleats and push down into place. To prevent a possible man overboard situation, make sure the swim platform area is unoccupied and the cockpit aft fill-in backrest (door) is in place before each cruise. See Figure N23.



Figure N22: Walk-Thru Transom

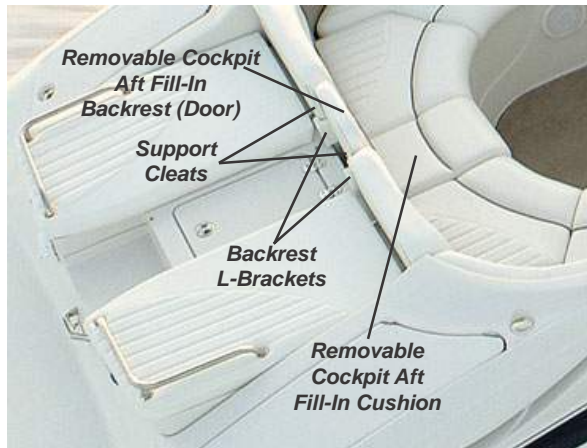

Figure N23: Walk-Thru Backrest Door & Fill-In Cushion



**WARNING**

Prevent falls overboard. Secure transom walk-thru backrest and stay inside cockpit while underway.



**WARNING**

To prevent personal injury, swim platform must not be occupied and transom walk-thru backrest door must be in place while engines are running.



**CAUTION**

To prevent personal injury, DO NOT sit on the transom walk-thru backrest door.

### NOTICE

When towing at highway speeds, be sure the fill-in cushions and backrests are properly secured (locked in position). Air currents (created within the interior when traveling) will lift the cushions/backrests up and out of the boat under certain conditions; especially when semi-trucks or other large vehicles pass by.

### Q. Aft Walk-Thru Center Fill-In Cushion

Certain models have a walk-thru transom design. A walk-thru center fill-in cushion along with the backrest create additional seating. To install the cushion either snap or slide it into place. See Figure N24.

### NOTICE

Ensure all removable cushions and/or backrests are properly secured or stowed to prevent possible loss from blowing out of the boat when operating at high speeds or towing.



Snaps

Figure N24: Center Aft Walk-Thru Cushion

### R. Sun Lounge Cushions / Sunpad

Certain Horizon™ models come equipped with a unique stern seat converts to either two separate lounges or one large sunpad. Storage compartments are located underneath cushions. See Figure N25, N26 and N27.





Figure N25: Separate Sun Lounge



Figure N26: Separate Sun Lounge - Sunpad



Figure N27: Sun Lounge Storage

Sun lounge with support pad style operation:

- 1) Lift up on the backrest until it clears the seat cushion.
- 2) Extend the cushion until it is even with the aft portion of the lounge pad and allow the support pad to rest on the seat cushion. See Figure N28.

- 3) The same procedure is used for the other sun lounge.



Figure N28: Sun Lounge - Support Pad Style

Sun lounge with hinging mechanism style operation:

- 1) Lift up on the seat strap and front portion of the seat cushion simultaneously until the cushion/backrest clears the seat cushion. See Figure N29.



Figure N29: Sun Lounge Lifting Strap

- 2) Extend the lounge until it is even with the aft portion of the lounge pad. If necessary, push down on the center cushion to even this pad with the rest of the lounge. See Figure N30.



Figure N30: Sun Lounge - Leveling Pad

- 3) Insert the support rod into the recessed hole underneath the forward lounge cushion and ensure the rod is resting squarely on the floor. See Figure N31.



Figure N31: Sun Lounge Support Rod

- 4) The same procedure is used for the other sun lounge.

**CAUTION**

To prevent personal injury or damage to the sun lounge/sunpad and hinge mechanism, be sure the support rods are used and properly positioned.

To turn the dual sun loungers into one complete sunpad (see Figure N32):



Figure N32: Sunpad

- 1) Slide the fill-in lounge backrest L-brackets onto the support cleats of the backrest. Certain models require that you simultaneously lift up both lounge backrests and then slide the fill-in lounge backrest L-brackets onto the support cleats of the backrest. The pattern of the pad should match. Gently lower backrests down into position. See Figure N33.



Figure N33: Insert Backrest Fill-In

- 2) Slide the center aft fill-in cushion onto support cleats of lounge cushions (if applicable). See Figure N34.



To prevent personal injury do not step on the aft fill-in cushion. Cushion could move and cause loss of balance.



Figure N34: Insert Fill-In Cushion

- 3) Snap the sunpad fill-in cushion in place. See Figure N35.



Figure N35: Snap in Fill-In Sunpad Cushion

- 4) Note: Support rods are used for both the sun lounge and sunpad configurations. Support rods may be stored in the storage compartment underneath the starboard cockpit cushion. Clips have been installed to hold the support rods. See Figure N36.



Figure N36: Support Rod Storage

To convert the dual sun loungers or sunpad back to stern seating:

- 1) Remove the fill-in cushions and fill-in backrest if applicable.
- 2) Remove the support rods and store in underseat storage.
- 3) Lift up on lounge backrest and push the lounge seat cushion back into seat position. See Figure N37.



Figure N37: Returning Lounge/Sunpad to Seat Positions

- 4) Repeat this procedure for the other sun lounge if required.
- 5) Insert fill-in backrest and fill-in cushion if applicable. Store any cushions not being used to prevent loss or damage.

**S. Center Cockpit Cushion - (Certain Models Only)**

The center cockpit cushion is installed on the engine hatch and provides comfortable seating for your passengers. By simply lifting up and out on the center cockpit cushion, minimum access can be gained to the engine compartment for quick inspections.

**T. C-Wrap Aft Lounger Seating**

Standard on certain models is an aft C-wrap style seating configuration. See Figure N38. Storage and cooler access can be gained by lifting up the various cushions. Use of both hands when lifting up on a cushion will make for an easier operation. Also, quick inspection access to the engine compartment can be gained by lifting up and out on the center cockpit cushion.



Figure N38: Aft C-Wrap Lounger Seating

**U. Port Lounger - Settee**

A cozy settee lounger is provided on portside, in front of the cockpit refreshment center, on certain Horizon™ models. See Figure N39. The settee not only provides a comfortable and elegant seating arrangement but offers additional storage space underneath. To gain access to the storage below, lift up on the settee cushion and pull out.



Figure N39: Port Settee Lounger

**N - 2 EXTERIOR UPHOLSTERY CARE**

**A. Cleaning Vinyl**

**NOTICE**

Vinyl upholstery should be cleaned and maintained in accordance with the manufacturer's recommendations and instructions.

The vinyl material used on the exterior upholstery should be cleaned regularly with warm water and a mild dish soap or Vinyl Finish Vinyl Cleaner® using a soft clean cloth, then rinse with a soft clean cloth. For dirt buildup, spray Vinyl Finish Vinyl Cleaner®, let soak for approximately ten (10) minutes, then gently scrub with a soft bristle brush. Be sure to thoroughly rinse the vinyl after washing with mild dish soap or Vinyl Finish Vinyl Cleaner® to remove all residue. Towel dry the vinyl. Periodic spraying of the seats with Lysol Spray Disinfectant™ will help retard mildew.

To further protect the vinyl from early degradation, use 303 Aerospace Vinyl Protectant®. Spray on, then wipe dry. 303 Vinyl Protectant should be applied every 3-5 weeks when boat is in use. Regular cleaning with mild soap and water or Vinyl Finish Cleaner will not remove the 303.

**NOTICE**

DO NOT apply vinyl protectants such as Armorall®. The manufacturer does not recommend this product because it removes the oils present in vinyl that keeps vinyl soft.



**A recommended “Cleaning Kit” includes:**

- Ivory Dishwashing Liquid™ and water
- Clean, white towels
- Soft bristle brush
- Fantastik Spray Cleaner™
- Denatured Alcohol
- Hemisphere Ink Remover® - (for ordering information call 800-247-9901)
- Vinyl Finish Vinyl Cleaner® - (everyday cleaning & care, call 800-247-9901)
- 303 Aerospace Vinyl Protectant® - (for ordering information call 800-247-9901)
- Tough Duty Cleaner™ - (to locate the nearest distributor, call 800-537-8990)
- Ammonia and hydrogen peroxide

To remove stains, follow the general guidelines listed below and/or refer to the Step-by Step Cleaning Instructions table:

**General Stain Removal Guidelines**

**1. Basic Stains/Grease/Pencil/Dirt:**

Ivory (mild) Dishwashing Soap™ and water, or Fantastik Spray Cleaner™ applied with a medium-soft brush or Vinyl Finish Vinyl Cleaner® using a soft clean cloth, then rinse with a soft clean cloth.

**2. Tough Stains/Adhesive/Teak Oil/Rust:**

Tough Duty Cleaner™; rinse with soap and water or spray with Vinyl Finish Vinyl Cleaner®, let soak for approximately ten (10) minutes, then gently scrub with a soft bristle brush. Thoroughly rinse vinyl and dry.

**NOTICE**

To prevent possible damage to the vinyl, rinse with soap and water after applying the Tough Duty Cleaner™ or Vinyl Finish Cleaner®. Then rinse and dry.

**3. Ink:**

Denatured alcohol or Hemisphere Ink Remover®.

**4. Mildew Stains:**

To kill bacteria creating the mildew, vigorously brush the stained area with a 4-to-1 mixture of water and ammonia; rinse thoroughly with water and dry.

**5. Tough Mildew Stains:**

Apply a mixture of one (1) teaspoon ammonia, one-fourth (1/4) cup of hydrogen peroxide, and three-fourths (3/4) cup of distilled water; rinse with water and dry.

Step-by-step cleaning instructions				Legend
Type of stain	STEPS: 1,	2,	3	
General Care	A	B		A. Medium soft brush, more soapy water Rinse / Dry
Dirt build-up	A	B		
Ballpoint ink*	E	B	A	
Chewing gum	D	A		
Coffee, tea, chocolate	B			
Grease	D	B		B. Vinyl Finish Vinyl Cleaner® Rinse / Dry
Household soil	A	B		
Ketchup	A	B		C. One (1) tablespoon of ammonia; one-fourth (1/4) cup of water Rinse / Dry
Latex paint	A	B		
Lipstick	A	B		
Mildew or wet leaves*	C	B	A	D. Wipe or scrape off excess (with gum with ice before hand)
Motor oil	B			
Oil-based paint	D	B		E. Hemisphere Ink Remover Rinse / Dry
Permanent marker*	E	B	C	
Spray paint	B			
Suntan lotion*	A	B		
Tar / Asphalt	D	B		
Yellow mustard	A	B	C	

All cleaning methods must be followed by a thorough rinse with clean warm water.

Certain household cleaners, powdered abrasives, steel wool and industrial cleaners can cause damage and discoloration and are not recommended. Dry cleaning fluids and lacquer solvents should not be used as they will remove the printed pattern and gloss. Waxes should be used with caution as many contain dyes or solvents that can permanently damage the protective coating.

\*Suntan lotion, tree pollen, wet leaves and some other products can contain dyes that stain permanently. Care should be exercised and boat covers should be utilized.

Step-By-Step Vinyl Cleaning Instructions Table



**NOTICE**

When docking or mooring your boat be aware of your surroundings i.e. trees with pollen, wet leaves, berries etc. These and other items can contain dyes that stain permanently. Utilize weather covers whenever possibly to protect vinyl from potential stains.

**NOTICE**

ALWAYS CLEAN STAINS IMMEDIATELY! DO NOT use 409 Cleaner™ or Armorall™ on vinyl. Do not use kerosine, gasoline or acetone as they will remove the protective marine topcoat.

**NOTICE**

All cleaning methods must be followed by a thorough rinse with water and drying.

Additional cleaning information is provided by the manufacturer and is included with this manual.

Four Winns offers a variety of optional weather covers for protection of the boat and associated equipment. Continued exposure can damage the upholstery and seating. The seating can become thoroughly saturated with water if not adequately protected. Refer to Section O - Weather Covers for more information.

**NOTICE**

The appearance and longevity of the exterior upholstery will be affected by water saturation. Protect these items appropriately.

**B. Exterior Carpets**

The removable exterior grade carpeting may be periodically washed with mild laundry soaps or shampooed, dried and reinstalled. It is 100% UV stabilized Olefin™ Polypropylene fiber with rubber backing. See Figure N-40.

**NOTICE**

Prior to using any mild laundry soaps or carpet shampoo, always conduct a color-fast test on a small inconspicuous portion of carpet before applying to entire carpet.

**NOTICE**

DO NOT dry carpeting in an automatic dryer.



*Figure N40: Cockpit Lay-in Carpet*

**C. Cleaning and Maintenance**

The following information should be useful in helping you keep your carpet looking well maintained.

Carpet made with Olefin™ fiber possesses built-in stain and soil release for easy, less costly maintenance. Regular vacuuming and occasional shampooing will help it stay attractive and serviceable.

**D. Stain Removal Testing**

Even the most stubborn stains can be removed from Olefin fiber following the procedures outlined. Stains were selected as being representative of spills commonly occurring on carpets. Stains were pressed into the carpet to simulate foot pressure following a spill. Stains were applied to a two-inch square section and allowed to penetrate. Removal was performed after two weeks. Carpets were tested for stain removal by an independent laboratory. Stain removal was effective for the all the stains selected. Results are shown in the table on the following page.

**E. Stain Removal Procedures**

Regular maintenance such as vacuuming, hosing or washing should be performed. Most stains and mildew are easily removed from carpet made with Olefin fiber using common household cleaners. Refer to Table I. Olefin™ fiber is so resistant to chemical attack that Clorox™ bleach may be used to clean up any mildew that may result from excessive wetness.

**Code for stain removal procedure (See Table 1):**

“A” Apply warm water and household detergent in minimal amounts to stained area. Sponge or scrape until stain is removed. Rinse with clean water.

“B” Apply warm water and household detergent. Work well into stained area then flush with warm water.

Most stains should be easily removed however, if the stain persists, the cleaning procedure should be repeated to insure stain removal. Remember, the sooner the stain removal process begins, the easier the stain will be to remove.

**NOTICE**

Do not use dry cleaning solvents on carpet or vinyl. **Permanent damage** to the fiber will result.

**N - 3 REPLACEMENT UPHOLSTERY**

Should upholstery become severely soiled, torn, or in some manner damaged, replacement upholstery cushions are available. Larger upholstery items have separate component parts for easier serviceability.

Depending upon the year and model of the boat, most upholstery parts can be obtained through your Four Winns servicing dealer within a short period of time.

STAIN	REMOVAL PROCEDURE
Automotive Grease	A
Automotive Oil (New or Used)	A
Bacon Grease	A
Berry Stain	A
Blood	A
Butter	A
Catsup or Mustard	A
Chewing Gum	A (Repeat)
Chlorine Bleach (5%)	A
Chocolate (Melted)	A
Clay	A
Coffee or Tea	A
Cola	A
Crayon	B
Dye	A
Egg	A
Feces	A
Fish Formula	A
Fruit Juice	A
Furniture Polish	A
Gravy	A
Ice Cream	A
Ink (Permanent Black)	B
Ink (Scripto, Ballpoint)	B
Iron Rust	A
Lipstick	B
Mayonnaise	A
Milk	A
Latex Paint	A
Oil Base Paint	B
Polish	B
Rust	A
Salad Dressing	A
Shaving Cream or Lotion	A
Tar	B
Urine	A
Vomit	A
Water Colors	A
Wax	B
Wine	A

*Table I: Stain Removal*



#1



#2

Rotate the handle and pull lounge cushion forward (in the direction of the arrow) until it stops.



#3

Rotate handle and pull lounge cushion back (in the direction of arrow #1) while simultaneously pushing down on the backrests (in the direction of arrow #2) until lounge is in the reclining position.



#4

Raise either lounge cushion and lift the headrest brace into position so the feet of the brace insert into the recessed slots of the cushion frame. To lower the headrest, lift the cushion enough to allow the brace to retract. Lower the cushion.



#5



#6

Rotate handle and push lounge cushion back (in the direction of arrow #1) while simultaneously pulling up on the backrest (in the direction of arrow #2) until lounge stops.



#7

Push lounge cushion in the direction of arrow until stops. Ensure lounge cushions are locked in place.

**Figure N41: Steps to change the “adjusting” lounge**  
 (Photos #1-#5 depict placing lounge into the “reclining” position.  
 Photos #6 & #7 depict returning the lounge into the “back-to-back” seat position.)

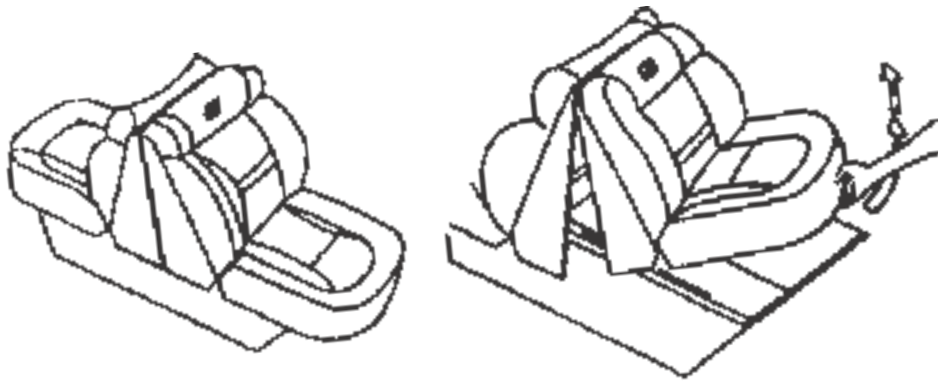

**Step 1:** Lift front of seat upward until seat releases. Pull forward until it stops.

**Step 2:** Repeat Step 1 with the rear seat.

**Step 3:** Push center of the seat down until seat becomes horizontal. Note: There is no headrest adjuster.

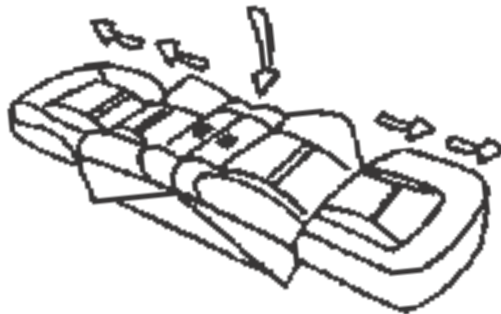

*Figure N42: Steps to change the “non-adjusting” lounger to the “down” position.*

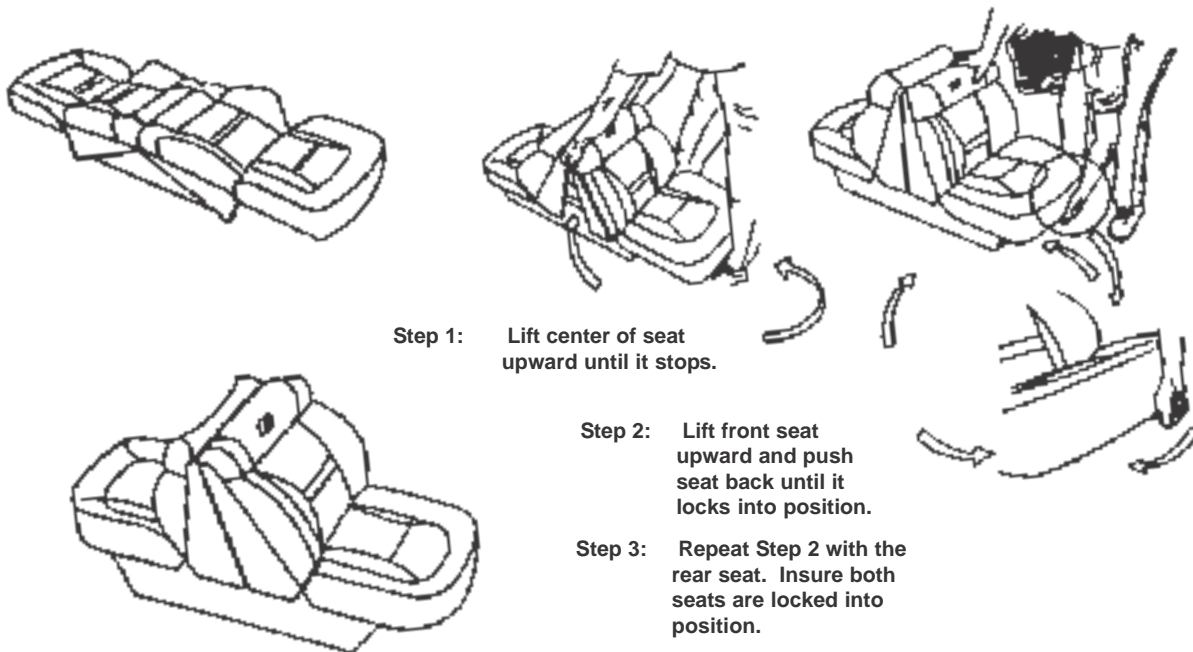

**Step 1:** Lift center of seat upward until it stops.

**Step 2:** Lift front seat upward and push seat back until it locks into position.

**Step 3:** Repeat Step 2 with the rear seat. Insure both seats are locked into position.

*Figure N43: Steps to change the “non-adjusting” lounger to the “up” position.*



# WEATHER COVERS

## O - 1 GENERAL INFORMATION

Weather covers for the cockpit areas are available on all Freedom™ and Horizon™ models. Four Winns® covers are designed and intended to provide protection of the cockpit seating areas.

Four Winns utilizes acrylic-type material for all its covers. All Freedom™ and Horizon™ canvas except mooring covers consist of 100% acrylic material and is color matched to the boat. The mooring covers are made of 10 ounce acrylic and come in dark tan (mica) only.



Never use any form of open flame cooking device while under, in any area fully enclosed, or near any acrylic weather cover. This material is flammable.

During the manufacture of the weather covers, the smallest possible needle and highest quality UV stabilized, bonded polyester thread is used in the stitching.

The weather cover is water repellent but not water proof. During a hard rain, you may notice a light mist permeating through a weather cover. This is normal. If the seams leak, they can be sprayed with Scotchguard™ or similar water repellent or a seam sealing compound can be applied. Keep objects from contacting the inside of the cover. Leakage may occur at point of contact.

Weather covers must be installed taut or will be damaged by accumulation of rain water.

### NOTICE

Periodically check weather covers for accumulation of water. Damage to the bow assemblies may otherwise result. Make sure cover is taut to avoid puddling of water.

After use, the top canvas should be rolled up into the boot (if supplied) and secured.

### NOTICE

NEVER fold or store a wet weather cover. This can lead to mildew or shrinkage. Roll rather than fold the enclosure curtains. Sharp folds increase the chance of cracking the clear vinyl.

### NOTICE

DO NOT use the weather covers for outdoor winter storage. The weight of the snow or heavy rain can cause severe damage to the material or top structure. Refer to O-3 Winter Storage in this manual for more information.

When snapping covers to the boat, apply direct downward pressure on the snap. When unsnapping, rotate the snap and cover upward at each snap location.

### NOTICE

Remove snaps one at a time to prevent damage. DO NOT rip off or pull the weather cover as a whole; acrylic material may tear at snaps.

## A. Bimini Top

A bimini top is available on most Freedom™ and Horizon™ models. This style is a “freestanding” top and is supported only by the bow assembly. Refer to Figure O1.

To install:

1. Unboot and attach the bimini main bows to the deck mounts.
2. Extend the forward portion of the bimini and attach the forward nylon straps to the strap eyes.

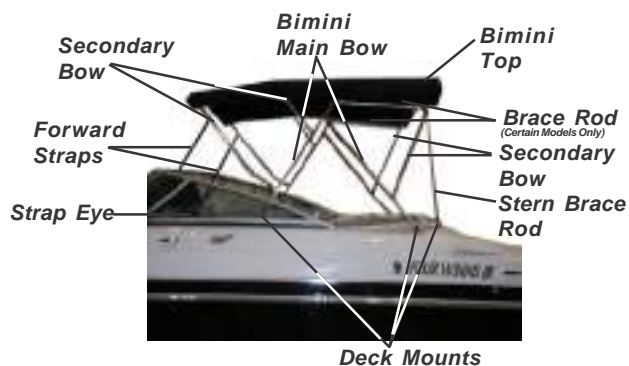

Figure O1: Bimini Top



3. Extend the rear portion of the bimini and attach the brace rods to the secondary bow (if applicable).
4. If applicable, attach the stern brace rod to the stern bow (secondary) and then to the stern (angled) deck mount.
5. Adjust the forward straps and secondary bow couplers for tautness if necessary.
6. Snap forward windshield connector (clear visor) to windshield (if applicable). Starting at the walk-thru windshield may prove to be easiest. Windshield snaps can be adjusted to match snaps in canvas.
7. Zip forward windshield connector section to the bimini top.

To close and boot (mounted storage) the bimini, reverse the procedure described above. Brace rods, if applicable to your model, snap into storage clips for safe keeping while booted.

You may choose to run your Freedom™ and Horizon™ with the bimini top either fully deployed or folded together (closed) and secured with the boot provided. Either way it is designed to remain mounted. No storage is provided for this top in your boat.

**NOTICE**

Use two people to remove the bimini top (winter storage). This will help minimize the risk of injury and help prevent damage to the upholstery, the bimini top, and/or the boat.

**NOTICE**

Aft/Main bimini canvas deployment should only be utilized at or below moderate cruising speed (approximately 0-30 mph). Avoid full throttle operation of boat while having canvas deployed. Four Winns recommends booting the canvas before running at or close to maximum speed. In so doing you will help to maintain the life of the canvas and hardware. Also, the wind should be taken into consideration when determining operating speed with canvas deployed. The boat speed plus (+) wind speed should not be exceed 40 mph.

**B. Camper Canvas**

The camper canvas is an option available on certain Horizon™ models which encloses the cockpit area and allows for overhead space. The camper utilizes the exist-

ing bimini top and forward connector. Covers roll up to expose the window screens. See Figure O2. Your Four Winns dealer can assist you with your canvas selection as well as the installation.

To install:

1. Install bimini top and forward connector as previously instructed.
2. Zip in the bimini side curtains to the bimini top. Snap canvas to windshield beginning at forward edge.
3. Zip the camper side curtains to the bimini top and bimini side curtains. Snap the edge portion of these curtains to the deck. It may prove easiest to start snapping the curtains at the forward portion of the canvas and work your way down along the deck.
4. Unroll the aft camper curtain and zip the curtain to the camper.
5. Depending on which the model you have either snap the bottom portion of the aft curtain to the transom and/or attach shock cords to deck.



*Figure O2: Camper Top*

For camper storage, reverse the procedure described above.

**C. Full Canvas**

The full canvas option is available on certain Freedom™ and Horizon™ models. See Figure O3. It is comprised of a convertible top, side curtains, aft curtain and forward cover. Please see the following for descriptions and installations of each peice.

Aft Curtain Side Curtain Suntop Forward Cover



Figure O3: Full Canvas

**D. Convertible Top (Suntop)**

On certain Freedom™ and Horizon models, a convertible top is available which covers the cockpit area. A canvas boot is provided which is used to encase the suntop for storing. Note: No storage is provided for this top in your boat. It is designed to remain mounted on the boat or removed completely. See Figure O4.



Figure O4: Convertible Top

To install:

1. Attach the main bow to the windshield mount and unroll the canvas.
2. Snap the forward edge of the top to the windshield. Windshield snaps will slide to adjust to the canvas.

**NOTICE**

The center snap should be centered on the windshield, then adjust all other windshield snaps to align to canvas snaps.

3. Adjust the secondary bow to support the canvas and attach the nylon strap to the strap eye located on the deck. The strap can be adjusted for tautness.

**NOTICE**

Couplers on the bow extensions allow for vertical adjustment. Horizontal adjustments can be made with the buckle located on the nylon strap and by sliding the secondary bow(s) up or down along the main bow.

**E. Side Curtains**

The side curtains are used to enclose the area between the windshield wings and canvas. Each curtain will zip to the underside of the suntop and snap to the windshield wings. Windshield snaps will slide to adjust to the curtain.

**NOTICE**

DO NOT FOLD THE SIDE CURTAINS! Damage may result. Always roll the side curtains up to prevent damage to the isinglass.

**F. Aft Curtain**

The aft curtain encloses the remaining cockpit area when the suntop is installed. Refer to Figure O3.

To install:

1. Attach the aft curtain to the zipper provided on the rear portion of the suntop.
2. Secure the rear corners.
  - a. If the canvas has snaps along the aft edge, secure the corners.
  - b. If the canvas has shock cords (elastic cords) along the aft edge, attach to knobs as shown in Figure O5.

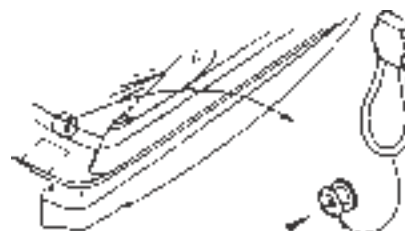

Figure O5: Shock Cords

3. Finish snapping canvas to deck.

When storing the aft curtain, roll the canvas which will keep the isinglass from creasing.

**G. Forward Cover**

The forward cover is available on most Freedom™ and Horizon models. It is installed over the bow seating area and is snapped to the deck. An adjustable pole is provided to adjust the canvas for tautness and prevent the build up of water. Refer to Figure O3.

**H. Cockpit Cover**

The cockpit cover is used to cover the complete cockpit area and is intended as a short term storage cover. The cockpit cover is available on most Freedom™ and Horizon™ models. See Figure O6.

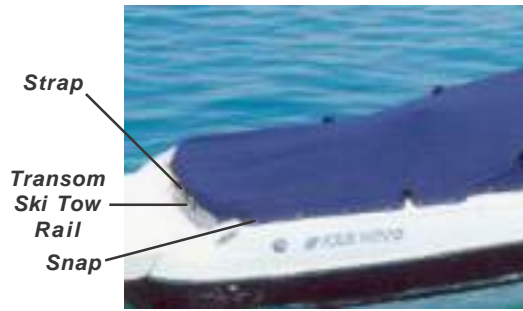

**Figure O6: Cockpit Cover**

To install:

1. Snap the forward edge of the cockpit cover to the bottom edge of the windshield track. Snaps can be adjusted on the windshield track if necessary.
2. Snap the cockpit cover sides to the deck.
3. Secure the rear corners and aft edge of the cockpit canvas. This is done with the use of any combination of snaps, elastic cords and/or straps. If straps are used they usually are placed around the transom rail and snapped. See Figure O7.
4. Place the adjustable poles in position. The adjustable poles are provided to adjust the canvas for tautness and prevent puddling.

To store the cockpit cover we recommend folding the cover in half, lengthwise and then rolling the cover up.



**Figure O7: Cockpit Cover - Straps & Snaps**

**I. Mooring Cover**

Mooring covers, available for most Freedom™ and Horizon™ models, are intended for longer term storage and spread over the entire boat. If used in areas with snow accumulation, be sure to support the canvas adequately and inspect frequently for snow loads or damage will occur. Refer to O-3 Winter Storage for additional information. See Figure O8.



**Figure O8: Mooring Cover**

To install:

1. Spread mooring cover over entire boat.
2. Install adjustable poles in the rear cockpit and forward bow areas. Be sure the canvas is taut and no pockets (sags) exist.
3. Tie off at the transom.
4. Nylon loops are provided for attaching rope or bungee cords to the trailer or from side to side (under the boat).

**O - 2 TRAILERING**

High winds encountered during trailering your boat can severely damage most weather covers. If an extended trip at highway speeds is planned, the top and other weather covers should be in the down position or removed entirely. This will prevent damage and loss.

**NOTICE**

DO NOT tow your boat at highway speeds with weather covers in place. High winds encountered during trailering your boat can severely damage most weather covers. Damage to weather covers incurred as a result of trailering your boat is not covered under warranty.

**O - 3 WINTER STORAGE**

The boat must be properly protected during winter dry dock storage. A winter storage cover is advisable. Many marine dealers offer shrink-wrap enclosures for outdoor storage. See a Four Winns dealer for information on the availability of winter storage covers or other alternatives for storage.

When storing outdoors, make sure the supporting framework keeps the weight of the snow and rain from accumulating on the storage cover. Proper ventilation must also be provided or dry rot and mildew will occur. See Section R - General Maintenance for additional winter storage information.

**O - 4 USE OF WEATHER COVERS AND CARBON MONOXIDE**

When an engine is running, a natural vacuum may exist with the right wind and sea conditions to allow exhaust gases (which includes carbon monoxide) to seep into the boat. When canvas is utilized, this compounds the possibility of this occurring and inhibits natural ventilation. For more information, refer to Section B-2 - Carbon Monoxide in this manual.

The carbon monoxide in exhaust fumes can be hazardous. It is important for you and your passengers to be aware of the potential safety hazard created by exhaust fumes. Familiarize yourself with the symptoms of individuals overcome by carbon monoxide, and most importantly, ways you can protect yourself and your guests. See Figure O9 - Carbon Monoxide Canvas Warning Label and Figure O10 - Carbon Monoxide Warning Label.

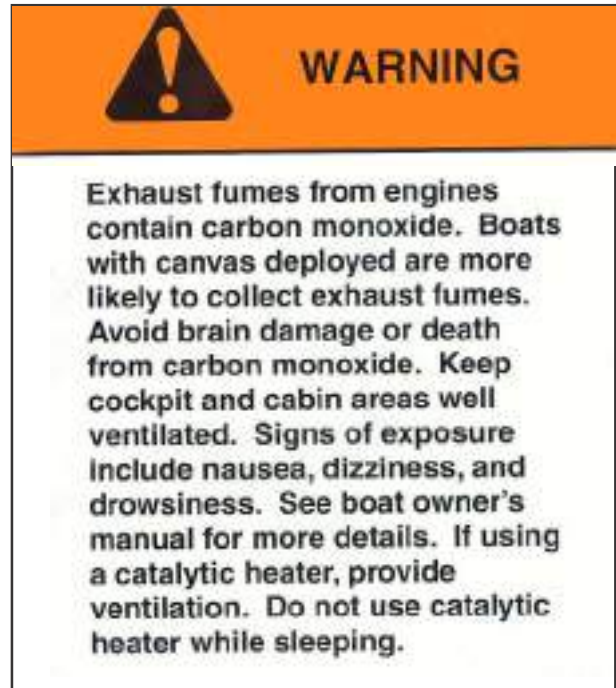

*Figure O9: Carbon Monoxide Canvas Warning Label*

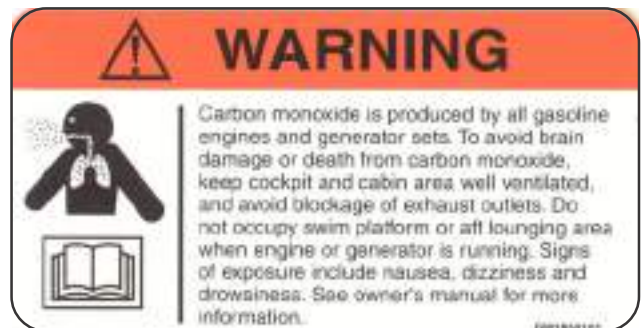

*Figure O10: Carbon Monoxide Warning Label*



**O - 5 MAINTENANCE**

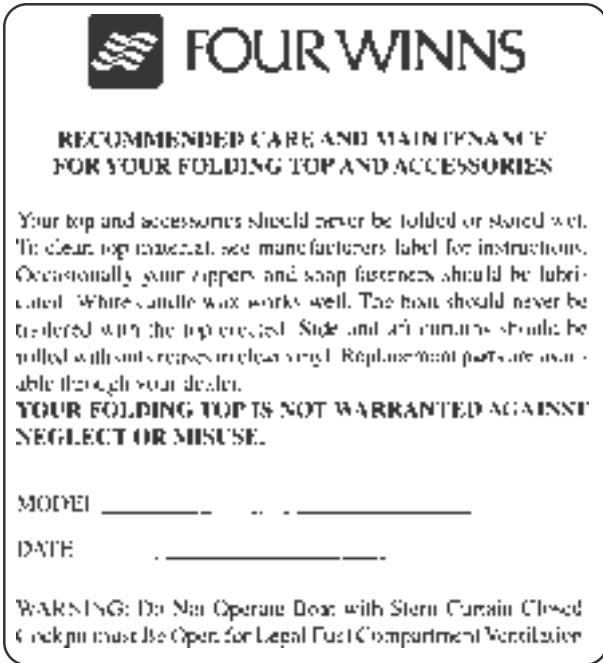

*Figure O11: Canvas Care & Maintenance Tag*

Moisture, dirt, chemicals from industrial fallout, heat, ultraviolet rays and in some cases, salt water are factors which affect the longevity of acrylic covers. See Figure O11.

1. Moisture can cause shrinkage and mildew. Allow the cover to dry thoroughly before disassembling tops. Keep it clean and well ventilated to prevent mildew. Spraying the weather cover with Lysol Disinfectant™ or similar product will help prevent mildew.
2. Dirt creates a starting point for mildew when moisture is present. Clean the top with a sponge or soft scrub brush and mild detergent when the cover is installed. Make sure cover is snug to help prevent shrinkage.
3. Chemicals cause decay if allowed to accumulate for long periods of time. Keep the cover clean to prevent decay.
4. Heat can cause cracks in vinyl components and stiffening of fabric when enclosed in plastic or polyethylene. DO NOT store the weather cover in polyethylene under direct sunlight or high temperature situations.
5. Ultraviolet degradation may occur under prolonged exposure to direct sunlight. Store the top in the boot when not in use.

6. Salt water can corrode brass, aluminum, or stainless steel fittings and fasteners. Keep fittings clean, lubricated, and waxed to prevent corrosion.

Clear vinyl curtains and windows demand extra care to prevent scratching. DO NOT use cloth or chamois skin. Dirt or grit in the cloth will scratch the vinyl window. Hose clean water onto vinyl to rinse off salt, dirt, or grime.

**NOTICE**

DO NOT use hot water. DO NOT dry in an automatic dryer. DO NOT dry clean or steam press.

Leakage after cleaning may be the result of insufficient rinsing. Re-rinse. If leakage continues, apply a coat of silicone air drying water repellent, such as Scotchguard™. See your Four Winns dealer for additional information on weather covers.



# FIBERGLASS AND HULL INFORMATION

## P - 1 HULL DESIGN INFORMATION

Four Winns® boats are designed using the sound engineering and mathematical principles of hydrostatics, hydrodynamics, structure, and strength of materials. The materials utilized provide optimum strength at the lightest possible weight. The exact fiberglass laminate schedule and construction techniques of each part is determined in accordance with the strength and rigidity required.

All Four Winns Freedom™ and Horizon™ models include our patented **Stable-Vee®** hull design. Pods on either side of the outdrive extend the running surface beyond the transom. These pods, plus the unique distribution of deadrise from transom to bow, allows Four Winns to place more hull in the water than deep-vee designs of similar length and beam. This results in better boat handling whether on plane, during turns, or at rest.

## P - 2 FIBERGLASS CONSTRUCTION

The fiberglass components of Four Winns® boats are of the finest quality materials, workmanship and construction techniques available. This ensures the structural integrity to provide years of boating enjoyment with minimal maintenance.

The construction of a Four Winns® hull begins with the application of gel coat to the mold. The gel coat is approximately 25 mils thick. A coat of resin and chopped fiberglass is then sprayed into the hull and carefully hand rolled until it is securely affixed to the gel coat.

A number of fiberglass layers and woven roving are applied to the above laminate. Each layer is hand laid and hand rolled. The keel and chine areas have fiberglass woven roving overlapped in these areas to provide additional strength. Some models utilize encapsulated end-grain balsa core or coremat laminates to achieve additional rigidity. Others utilize additional laminations of woven roving to maintain strength and rigidity.

The hull support stringers are located using special tools, and are fiberglassed into place. This ensures a strong, rigid hull, permanently formed into a solid assembly, free of distortions.

Fiberglass cockpit liners and seat base are constructed similar to the hull. Balsa core or coremat laminations are utilized when necessary.

In addition to a thorough visual inspection of each fiberglass component, samples are measured using special equipment, for fiberglass reinforcement to resin ratio, laminate configuration, weight and thickness. By these procedures Four Winns ensures proper composition.

## P - 3 EQUIPMENT INSTALLATION

Many boats are used for specific purposes or under conditions which require the addition of special equipment to the hull or deck. Special care must be taken during the installation of any equipment to a fiberglass component. A polysulfide or butyl based sealant should be used to seal installations below the water line. Silicone “marine” seal or similar bedding compound should be used elsewhere.

### NOTICE

DO NOT install any item onto or through the hull without adequately sealing the hull area penetrated by the installed item or related fasteners. Improper installations could cause leakage or allow water absorption and thus cause serious hull damage.

Always predrill fastening holes with a proper size bit. Predrilling will help prevent the fiberglass from splintering and thus causing unsightly damage. Also, countersink holes to prevent the gel coat from chipping.

Any equipment which will be subjected to cyclic loading or significant force should be through-bolted to a fiberglass component. A butt block or backing plate should be used to strengthen any area onto which an item will be mounted.

**P - 4 FIBERGLASS CARE & MAINTENANCE**

Fiberglass is affected by weathering processes and requires maintenance on a periodic basis to help maintain the beauty and shine. The effects upon the gel coat will be dependent upon boating conditions, storage, type of use, and the care given to the boat during the boating season.

Four Winns utilizes fade-fighting gel coat in the exterior finish. It is specially formulated to resist fading and yellowing, and retain more of its original gloss than better grade gel coats. However, it is still important to maintain the gel coat to protect the finish.

**A. General Maintenance**

For fresh water use, the boat should be washed once or twice a month. When using in a salt water environment, considerable more care will be necessary. Be careful when selecting a cleaning agent. Hand dishwashing detergents are usually gentle and are recommended for cleaning gel coat. Cleaning products such as Ivory™ or Dawn™ hand dishwashing liquid can be safely used. Always read the label before using any product.

**NOTICE**

DO NOT use acetone, paint thinner, solvents, or strong alkaline based detergents, nor cleaners with a “gritty” and abrasive texture. Avoid products which contain sodium phosphate. Common examples of these types of household cleaning agents are: Tide™, Oxydol™, Janitor-in-a-Drum™, Fantastik™, Clorox™, etc. Always read the label before using an agent.

There are several products available which are specifically designed to clean fiberglass exterior finishes. Many companies like Johnson & Johnson®, Turtle Wax®, etc. manufacture cleaning fluids mild enough to clean without stripping the wax.

**NOTICE**

Treading on a soiled fiberglass surface can severely scratch and mar the finish. Keep the fiberglass as clean as possible.

When cleaning nonskid areas, DO NOT attempt to use a wire brush or sandpaper because this will remove the nonskid gel.

Apply wax once or twice a year to maintain gel coat lustre. Read the label before using any product. Make sure product is applicable to fiberglass. Also, consult a Four Winns dealer for his recommendations.

**NOTICE**

Do not use carnuba based waxes. This type of wax yellows over time and makes the fiberglass appear yellow.

 **CAUTION**

Waxing decks, cockpit floors or other areas on which one walks is not recommended. Waxing will produce a very slippery surface, especially when wet. Wax may also buildup in the nonskid surfaces. Be sure all persons wear deck shoes while aboard the boat. Footing will be improved and feet will be protected from accidental cuts and bruises.

A darkening or discoloration of the nonskid surfaces can sometimes occur as a result of wax buildup. Exposure to the sun and elements can turn the wax darker, or occasionally can cause it to become flaky or powdery. To remove, use fine rubbing compound and a low rpm buffer (1200 to 2000 rpm). Apply light pressure and keep the buffer moving at all times to prevent heat build up. Read the directions before using any equipment.

**B. Weathering Effects on Gel Coat**

Weathering occurs from direct sunlight, water, chemicals, and dust. Some of the terms below describe the changes that can occur to the gel coat surface.

Chalking is a result of the gel coat’s top surface being broken down into an extremely fine powder. When this happens, the color whitens. The chalk is present on the surface only.

Fading is the uniform change in color. This happens when the actual pigments have changed color, especially from excessive chalking, or when the gel coat has either been stained or bleached by something.

Yellowing is gel coat which has a yellow cast and streaking usually deals with a stain or contact with another surface.

Gloss refers to the shine of the surface. This can change from sanding action, chalk, residues, or exposure.

Blistering refers to a condition in which the unprotected gel coat surface below the waterline has absorbed water and formed bubbles. See Section P-5 for additional information.

Follow the instructions below for boats that have weathered and chalked.

1. Wash.
2. Wax. If this does not work, then use a fine rubbing compound. If this does not work use 400 or 600 wet or dry sandpaper, followed by fine rubbing compound and wax.

When using wax or fine rubbing compounds, make sure to read the label and follow the directions. Some helpful tips are listed below.

1. Avoid working in direct sunlight. This dries out the wax or compound, and can stain the surface.
2. Use clean pads or cloths to apply a thin coating of wax or rubbing compound to a small area such as three feet by three feet. Remove any excess, and then rub the area with a buffing pad, or power buffer. Apply pressure only as necessary to restore the surface finish. Applying too much pressure or buffing in one place too long can permanently damage the surface.
3. After applying compound, always follow with waxing.

**NOTICE**

If using a power buffer, use a low rpm buffer with light pressure. Keep the pad wet and the buffer moving at all times to prevent heat build up.

**NOTICE**

To prevent gouges, uneven areas, or other damage from occurring, **DO NOT** use a power or belt sander when sanding. For best results, block sand the gel coat.

**C. Stains**

Stains can appear anywhere on the exterior of the boat and may be a result of contact with tar, plant sap, leaves, rust from metal fittings, and other materials. Surface stains may be removed with hand dishwashing soap, mild cleansers, or some household detergents. **DO NOT** use chlorine or ammonia products. These products can affect the color of gel coat. Commercial car washes use strong cleaners and should be avoided.

To remove stains, refer to the procedures below.

1. Wash area with hand dishwashing soap.
2. Begin with a small area such as three feet by three feet and apply a mild cleanser.
3. Rinse with clean water.
4. Follow with compound and waxing as outlined in procedure above.

If the stain is not removed by the hand dishwashing soap or mild cleanser, then the next procedure is to use either denatured or rubbing alcohol. If this does not work, consult your Four Winns dealer for professional assistance.

**NOTICE**

**DO NOT** use acetone, ketone, or other solvents to remove stains. These chemicals are flammable and may damage the gel coat.

**P - 5 FIBERGLASS REPAIRS**

Fiberglass is one of the most durable, strong, and forgiving construction materials afloat. It is resilient and normal repairs can be made without affecting the strength or structural integrity of the boat.

 **WARNING**

Striking docks, other boats, or submerged objects could create a very hazardous situation or severely damage the fiberglass. In the event an object is struck below or near the waterline, proceed directly and cautiously to the nearest service facility and remove the boat from the water. Closely inspect the hull for damage. If the outer fiberglass laminate was penetrated, repairs must be made prior to relaunch.

Occasionally, blisters, crazing, scratches, or damage to the fiberglass can occur. Repairs may be necessary to correct the problem.

**A. Scratches**

Scratches occur during normal use. Below is a step by step procedure to repair scratches.

1. Clean area with soap and water.
2. Apply a fine rubbing compound and buff.
3. Wax.

If this does not work, clean the area and sand lightly with 400 to 600 wet or dry sandpaper and follow with rubbing compound and wax.

**B. Gouges & Cracks**

Stress cracks and crazing are the appearance of hairline cracks in the gel coat surface. When present, these problems usually occur in the gel coat finish or the outer “skin coat” fiberglass laminate. The appearance of these cracks does not pose a threat to the structural integrity of the boat. In most cases, they are cosmetic and can be treated.

Cosmetic surface damage can be repaired as follows:

1. Sand the surrounding area with medium or fine grit sandpaper. Clean all marine growth, dirt, antifouling paint, etc. from the immediate area. **DO NOT** excessively scratch or gouge the surrounding area.
2. Use a hard, pointed tool to open the gel crack. Take care not to damage the surrounding gel coat.
3. Sand the crack or gouge so the edges are smooth and will allow proper “feathering” of the area.
4. Clean the area thoroughly. Make sure the area is dry before proceeding.

**NOTICE**

Be sure the structure and the ambient temperature are above 60 degrees F (15 degrees C) and the relative humidity below 70% immediately before, during, and after the repair.

5. If the nick or gouge is deep and penetrates through the gel coat, fill the area with fiberglass patching paste. Follow the directions on the can when mixing the paste with the catalyst.
6. After the gouge is filled and has dried, sand the patched area. Begin by using medium-fine grade sandpaper. Progressively use finer grade sandpaper until the surface is very smooth. If necessary, add filler and then sand the surface again.
7. Apply two or three light coats of matching fiberglass gel coat to the repaired area. Enough gel coat should be used so that the entire area is covered.

The gel coat must be catalyzed using up to 2% MEK Peroxide which can be purchased at a supplier handling fiberglass reinforced products. Contact your Four Winns dealer for assistance.

8. After ample drying time, sand the area using very fine wet/dry sandpaper. If the appearance of the area is still not satisfactory, repeat steps 2 through 8 as necessary.
9. If above the waterline, polish the area using a fiberglass rubbing compound and then wax. If the repaired area is below the waterline, the area should be primed and painted in accordance with the anti-fouling paint manufacturer’s instructions.

Gel coat, like paint, will change colors with time and exposure to sunlight (ultraviolet). For this reason, “matching” gel coat obtained from Four Winns may not match the gel color of a boat that has been exposed. However, this is the closest match commercially available. A fiberglass technician can tint the gel to be used in the repair to provide a closer color match.

More severe fiberglass damage, especially when structural, requires the expertise of an experienced fiberglass repair technician. See your Four Winns dealer for assistance.

**NOTICE**

Improper repair techniques can lead to further fiberglass component damage.

**C. Osmotic Blistering**

Osmotic blistering or “boat pox” is an unfortunate but not uncommon occurrence in fiberglass boats. Fiberglass is water retardant, not waterproof. When a boat is left in the water for a period of time, the fiberglass will absorb water. It is a natural process that can not be eliminated in production methods or material selection and usage. However, there are ways to control and possibly prevent blisters (see Section P-6). If you do encounter blisters, be assured that the blisters are merely cosmetic. They do not indicate a defect in the boat structure or lamination. Four Winns, along with most boat manufacturers, regard gel blisters as a standard maintenance item.

The repair procedure for gel coat blisters is similar to the procedures outlined in the previous section on cracks and gouges. There is an exception however, in that the hull must dry out for several days or possibly weeks before repairs can proceed.

To determine if the hull has dried sufficiently, tape one square foot of household plastic wrap securely to the hull bottom. Make sure all edges are sealed and let it stand for twenty-four hours. If condensation has accumulated under the plastic, the hull is still “wet” and must be allowed to dry longer before repairing.

When the repair is completed, an application of an epoxy barrier coat should be considered. This will help prevent the possibility of reoccurrence of blisters. Your Four Winns dealer or local ship store will have information on barrier coat products.

**P - 6 ANTIFOULING PAINT**

Four Winns recommends antifouling or bottom paint for boats which will be kept in the water for extended periods of time. Antifouling paint reacts with water to retard the growth of algae, barnacles and other marine growth on the hull. In addition to marine growth, it offers protection against excessive water pollution.

Antifouling paint begins reaction upon contact with water. After a season’s use or sooner under certain conditions, the antifouling paint may appear to be dissolving. This is due to the paint’s chemical emission that in turn retards marine growth. When this occurs, refinishing is in order.

Four Winns recommends reapplication of the antifouling paint seasonally. The effectiveness of the paint will be drastically reduced if used longer. Though Four Winns

has found the antifouling paints used to provide good marine growth protection in most water, other paints may be more effective in certain water conditions. See a Four Winns dealer for recommendations on antifouling paint use in your area.

**NOTICE**

During surface preparation, the hull should be sanded only enough to remove any foreign matter, and loose paint. **DO NOT** sand deeply into the gel coat, fiberglass cosmetic problems could later result. After sanding, the surface should be wiped with a rag treated with a cleaner recommended by the antifouling paint manufacturer. The surface must be clean and slightly rough to ensure paint adhesion.

Prior to application of the antifouling paint, the boat owner may consider coating the hull bottom with an epoxy coating. Four Winns recommends this procedure as a preventive and effective means of controlling osmotic blistering. Most major antifouling paint manufacturers also supply a line of epoxy undercoatings. Consult your Four Winns dealer for recommendations on epoxy undercoatings.

**P - 7 HULL SUPPORT**

Proper support of the hull while it is out of the water is imperative. Due to the design complexities, Four Winns does not recommend trailers or storage cradles be homemade. The boat is a valuable piece of equipment. **DO NOT** risk permanent damage to the hull structure in an attempt to save the cost of an adequate support. Improper support can lead to serious and permanent hull deformation.

 **CAUTION**

**Failure to adequately support the hull may result in permanent hull structure damage and will invalidate the hull structure warranty.**

**NOTICE**

When attempting to raise the hull, never allow one end of the boat to rise first, while letting the opposite rest momentarily on the outdrives or underwater gear. Serious damage to these components could result. **DO NOT** place lifting straps on underwater gear. Be sure the strap is against the hull surface only.



A trailer, or storage cradle designed for a larger or smaller boat will not provide proper support for the hull. This could lead to hull deformation and thus serious performance deficiencies.

Four Winns® trailers are available for the Freedom™ and Horizon™ models. Refer to Section S - Trailer Information for additional information.

# WOODWORK AND COMPOSITES

## Q - 1 HIGH-PRESSURE LAMINATE CARE

Some table tops, galley counter tops, shelving and drawer faces consist of a high pressure laminate, “formica” like material. The laminate may have either a matte texture or smooth finish and can be cleaned with mild dishwashing soap and water or other cleaning solutions such as Fantastik™. Always read the label before using any product.

**NOTICE**

DO NOT use abrasive cleaners or solvents on formica. DO NOT use Soft Scrub™ soap or similar cleaning products; they will scratch the surface and remove the shine.

**NOTICE**

DO NOT use table tops as a cutting board. The knife will leave gouges/marks in the surface of the table.

## Q - 2 STAR BOARD

Star board is a high density polyethylene (plastic) and is very durable and fade resistant. Star board requires little maintenance, and is being used in place of wood in many areas of the boat. The fill-in cockpit table is one example of where star board is used.

To clean star board, use a solvent-free, nonabrasive cleaner such as dishwashing soap or Fantastik™. Read the label before using any cleaning product.

**NOTICE**

Star board will stain when exposed to certain oils or chemicals. Always wipe up any spills immediately.

## Q - 3 BURLWOOD MAHOGANY ENHANCEMENTS

Mahogany enhancements are available on the Freedom™/Horizon™ models. They consist of a finished synthetic burlwood mahogany. This synthetic burlwood mahogany may be found in the instrument gauge panels, switch panels and ignition switch panels. Additionally, an optional woodgrain steering wheel is available for most models. See Figure Q1.



Figure Q1: Woodgrain Helm Representation

To clean, a damp cloth will usually suffice.

## Q - 4 LAMINATED FIBERGLASS

Some models come with a cockpit table option which consist of a laminated fiberglass material. See Figure Q2. It can be cleaned with mild dishwashing soap and water. Always read the label before using any product.

**NOTICE**

DO NOT use abrasive cleaners or solvents on cockpit table. DO NOT use Soft Scrub™ soap or similar cleaning products; they will scratch the surface and remove the shine.

**NOTICE**

DO NOT use cockpit table as a cutting board. The knife will leave gouges/marks in the surface of the table.



Figure Q2: Cockpit Table

**Q - 5 CORIAN® MATERIAL**

On models with a refreshment center, Corian® material is used for the countertops. The Corian® gives the refreshment center a rich look and makes for an extremely strong yet lightweight top. It can be cleaned with mild dishwashing soap and water, or other cleaning solutions such as Fantastik™. Always read the label before using any product. See Figure Q3.



*Figure Q3: Refreshment Center*

**Q - 6 ACRYLIC PLASTIC - (PLEXIGLASS)**

Acrylic plastic is utilized in most walk-thru doors, transom doors, portlight windows, electrical panel doors and certain glove boxes.

To clean acrylic plastic:

- 1) Rinse with plenty of water to wash off as much dirt as possible.
- 2) Using your bare hand, along with plenty of water, feel and remove any dried on dirt or mud.
- 3) Wash using a soft, grit free cloth or sponge and mild, nonabrasive soap or detergent.
- 4) Rinse thoroughly with water.
- 5) Blot dry using a clean, damp chamois.

**NOTICE**

**Never use** a dry cloth, duster, glass cleaning solutions or citrus cleaner on acrylic plastic.

**NOTICE**

**Do not use** solvents such as acetone, silicone spray, benzene, carbon tetrachloride, fire extinguisher fluid, dry cleaning fluid, lacquer thinner or ammonia. These solutions damage the acrylic surface.

You can use fine automotive acrylic rubbing and polishing compounds to remove fine scratches on acrylic.

# GENERAL MAINTENANCE

## R - 1 WINTERIZATION

### A. Prior to Lifting for Winter Lay-up

1. Pump out the head (dockside discharge if applicable), and be sure the holding tank is empty. Flush the head holding tank with soap, water and a deodorizer (e.g., Lysol Liquid™). Add more water if necessary. Have the cleaning solution pumped out.
2. Have the fuel tank either full or completely empty. See the Engine Owner's manual for recommendations. Also, check with the dry dock operators for recommendations. If winter storing with a full fuel tank, gasoline winterizer such as Sta-bil® Fuel Conditioner will reduce varnishing, condensation, etc.

#### NOTICE

If the fuel has been treated with winterizer, run engines for ten minutes to make sure the treated fuel is present in all lines and parts of the engine.

3. Drain water from the fresh water system (if applicable).
4. Winterize the engine and drive systems as recommended in the Engine Owner's manual. Portions of this winterization procedure may require that the boat be lifted.
5. If the boat is to be lifted or taken off the trailer, see Section P-7 - Hull Support in this manual for additional details.

### B. After Lifting

1. Remove the drain plug.
2. Thoroughly wash the fiberglass exterior, especially the hull bottom. Remove as much marine growth as possible. Wax lightly.
3. Lower boat onto cradle properly or place boat on trailer. Be sure boat is adequately supported. The boat should be raised slightly under the forward supports or trailer tongue to improve drainage to the transom drain.

4. Be sure all the water is completely drained from the fresh water system. Disconnect all hoses, check valves, etc. and blow all the water from the system using very low air pressure. The use of nontoxic, fresh water system antifreeze is recommended as an alternative to disassembling the water system. Refer to Section J-7 System Maintenance in this manual for information on winterizing the water system.
5. Winterize the head as recommended by the head manufacturer. If the boat is equipped with a holding tank, mix some antifreeze solution and pour it into the head. Transfer some of the antifreeze to the holding tank by flushing the head. Also, refer to Section J-7 - System Maintenance for additional information.
6. Ensure that all water is removed from the bilge pump and bilge pump lines. Dry the hull bilge, and self-bailing cockpit drain troughs. Water freezing in these areas could cause damage. See Section K-2 - Hull Drainage Systems.
7. Remove the battery(s) and store in a cool place. Clean the batteries using clear, clean water. Be sure the battery has sufficient water and clean terminals. Keep the battery(s) charged throughout the storage period. DO NOT store the battery(s) on a concrete floor or other damp or conductive surface.
8. Remove the alcohol/butane canister from the stove (if applicable) and store in a cool, dry place away from heat or spark.
9. Clean the boat interior thoroughly. Vacuum and/or shampoo carpets.
10. Wash exterior fiberglass components, wax lightly.
11. Clean exterior upholstery with mild soap and water. Rinse and dry thoroughly.
12. Remove all oxidation from exterior hardware and apply a light film of moisture - displacing lubricant.

### C. Prior to Winter Storage

1. Remove as many cushions as possible. Remove storage lids or hatches. Open as many locker doors, as possible. Leave these areas open to improve ventilation.
2. Spray the weather covers and the boat upholstery with Lysol Spray Disinfectant™. Enclosed areas such as storage locker areas should also be sprayed with Lysol Disinfectant™.
3. Place small dishes of rodent poison such as D-Con™ in a number of areas around the boat. Be sure dishes are placed near the head and the engines, as rodents will destroy upholstery, water intake and discharge hoses.
4. If the boat will be in outside storage, properly support a storage cover and secure it over the boat. DO NOT secure the cover tightly to the boat. This does not allow adequate ventilation and can lead to dry rot. DO NOT store the boat in a damp storage enclosure. Excessive dampness can cause electrical problems, corrosion, and dry rot.
5. DO NOT use the bimini top or camper top as a winter storage cover. The life of these covers may be significantly shortened if exposed to harsh weather elements for long periods.



#### WARNING

Placing an electric or fuel burning heating unit in the bilge of the boat during cold weather could cause fire or explosion and is not recommended.

#### NOTICE

Boats stored outside in areas with heavy snow accumulation are more susceptible to damage, and should be inspected regularly during the winter months

6. **Engine should be winterized according to the engine manufacturers manual.**

### R - 2 ENGINE FLUSH OUT

The optional engine flush out (if applicable) should be used to clean the engine of unwanted salt, mud, sludge, etc. which may have accumulated in the engine cooling system. Before winterizing the engine, flush out the system for at least five minutes.



#### CAUTION

Make sure that no section of flush hoses are in contact with moving or hot engine parts or abrasive surfaces such as screw threads, sharp edges, etc., which could damage the hoses. Damage to the hoses could cause leaks and possible flooding of the engine compartment. Periodically check hoses for abrasions.

#### NOTICE

The Four Winns flush out kit may be used with the boat in or out of the water and the engine OFF. If engine comes with flush out kit from the engine manufacturer, refer to engine operator's manual.

To flush out the engine with Four Winns installed flush out kit, follow the instructions below.

1. **Do not run engine during flushing procedure.**
2. Remove cap from coupling and attach swivel connector.
3. Attach water supply hose to swivel connector.
4. Turn water on and allow water to flush the engine and exhaust manifold for five to ten minutes.
5. Turn water off. Disconnect hose; replace and tighten cap securely.



#### CAUTION

Reinstall cap onto coupler after flushing. Flooding of the engine compartment will occur if the cap is not installed and tightened.



### R - 3 GENERAL MAINTENANCE SCHEDULE

SERVICE	AT LAUNCH AND FIRST OPERATION*	25 HOUR CHECK EACH SEASON*	BI-SEASONALLY OR EVERY 6 MONTHS OR EVERY 100 HOURS*	SEASONALLY OR EVERY 12 MONTHS OR EVERY 200 HOURS*
<b>Engine and Instrumentation</b>	Refer to Section E			
Engine Maintenance	As Recommended by the Manufacturer			
Inspect Exhaust System Hoses and Connections				
Check Propellers				
Check All Thru-Hull Fittings				
Test Emergency Shut-Off Switch				
Gauge Cleaning				
<b>Controls Systems</b>	Refer to Section F			
Throttle and Shift Adjustment				
Neutral Safety Switch Test				
Cable and Control Lubrication				
<b>Steering Systems</b>	Refer to Section G			
Linkage and Connection Inspection				
Stern Drive Torque Tab Adjustment				
Power Steering Service	As Recommended by the Manufacturer			
Steering Adjustments				
Steering System Lubrication				
<b>Electrical Systems</b>	Refer to Section H			
Inspect Battery Connections				
Check Battery Water				
Battery Cable Inspection				
12 Volt Electrical Equipment Operation				
12 Volt Wiring and Connection Inspection				
Shore Power Cord and Adapter Inspection				
Polarity Light Operation				
Receptacle and Connection Inspection				
<b>Fuel System</b>	Refer to Section I			
Inspect for Leaks				
Fuel Sender Inspection				
Fuel Filter Inspection				
Fuel Tank Inspection				

\* Or as Required

— Shaded areas indicate the time frame when service/inspection should be conducted.

SERVICE	AT LAUNCH AND FIRST OPERATION*	25 HOUR CHECK EACH SEASON*	BI-SEASONALLY OR EVERY 6 MONTHS OR EVERY 100 HOURS*	SEASONALLY OR EVERY 12 MONTHS OR EVERY 200 HOURS*
<b>Water Systems</b>	Refer to Section J			
Inspect All Water Systems				
Fresh Water & Grey Water** Tank Inspection				
Drain & Flush Fresh Water System				
Drain & Flush Grey Water System**				
<b>Ventilation and Drainage</b>	Refer to Section K			
Blower Operation	Before Every Use			
Blower Vent System Cleaning				
Bilge Pump Operation and Cleaning	Before Every Use			
Check Transom Drain Plug				
Porthole Operation				
<b>Interior Equipment</b>	Refer to Section L			
Head Maintenance	As Recommended by the Manufacturer			
Thru-Hull Fitting Inspection				
Refrigerator Cleaning				
Clean Cooler	As Required			
Stove Fuel System				
Stove Maintenance	As Recommended by the Manufacturer			
<b>Exterior Equipment</b>	Refer to Section M			
Check PFD's for Serviceability and Correct Number	As Required			
Check Charge of Fire Extinguishers	As Required			
Check Compass for Magnetic Deviation				
Windlass Maintenance	As Recommended by the Manufacturer			
Check Trim Tab Fluid Level				
Check Trim Tab System for leakage				
Clean Windshield	As Needed			
<b>Upholstery</b>	Refer to Section N			
Clean Upholstery				
Clean Carpet				
Spray Upholstery with Lysol				
Check Seat Hinges and Mounting Hardware				

\* Or as Required

\*\*If Applicable

 — Shaded areas indicate the time frame when service/inspection should be conducted.

SERVICE	AT LAUNCH AND FIRST OPERATION*	25 HOUR CHECK EACH SEASON*	BI-SEASONALLY OR EVERY 6 MONTHS OR EVERY 100 HOURS*	SEASONALLY OR EVERY 12 MONTHS OR EVERY 200 HOURS*
<b>Weather Covers</b>	Refer to Section O			
Wash Weather Covers				
Spray Weather Covers with Lysol				
<b>Fiberglass Components and Hull</b>	Refer to Section P			
Check All Fastenings (securing rails, seats, etc.)				
Clean Fiberglass Thoroughly				
Wax Hull Sides and All Non-Tread Areas				
Inspect Fiberglass Areas for Damage				
Perform Minor Touch-Up Repairs				
Sand Hull and Re-Apply Anti-Fouling Paint				
<b>Woodwork &amp; Composite Maintenance</b>	Refer to Section Q			
Clean Star Board	As Needed			
Clean Cockpit Tables / Countertop	As Needed			
Clean Plexiglass Components	As Needed			
<b>Trailers</b>	Refer to Section S			
Wax Trailer				
Lubricate Trailer Jack				
Lubricate Trailer Coupler				
Lubricate Trailer Winch				
Brake Operation	Before Every Use			
Brake Inspection				
Inspect Hubs/Disc Brakes				
Inspect Bearings & Seals				
Lubricate Bearings				
Springs, Hangers & Suspension Parts				
Wheel Lug Nut				
Wheels				
Tire Pressure & Condition	Before Every Use			

\* Or as Required

— Shaded areas indicate the time frame when service/inspection should be conducted.

# TRAILER INFORMATION

## S - 1 GENERAL TRAILER INFORMATION

The trailer must properly “match” the boat’s weight and hull design. Four Winns® trailers are designed specifically for each boat model. Four Winns® trailers meet or exceed the National Marine Manufacturers Association’s trailer requirements.

Four Winns manufactures bunk type trailers. The bunks are located specifically for Four Winns® boats and adequately support all parts of the boat. It is a “drive-on” type trailer which means winching the boat from the water is not necessary.

**NOTICE**

When winching the boat onto the trailer, **be sure the bunks are wet to prevent damage to the boat or trailer.** DO NOT attempt to winch the boat forward when out of the water. Damage to the winch stand/assembly or tongue could occur.

Four Winns offers both painted and galvanized trailers. The painted trailer is intended to be used in fresh water and the galvanized trailer in salt/brackish water.

**NOTICE**

Four Winns does not recommend the usage of painted trailers for salt/brackish water conditions, as trailer life may be substantially reduced.

### A. Regulations

Federal law requires that the trailer and tire registration information be compiled and recorded. The Four Winns® boat registration card includes trailer registration information. A trailer tire warranty card included in the owner’s packet, is to be filled out and returned to the tire manufacturer.

**NOTICE**

The warranty of the tire is administered by the manufacturer of the tire. The manufacturer of the tires on your trailer is Carlisle Tire. Please call 1-800-260-7959 regarding any warranty concerns relating to your tires.

Laws covering such items as trailer brakes, lights, safety chains, etc., will vary from state to state. Please contact the motor vehicle department in your state for additional information.

### B. Load Carrying Capacity

The certification label shows the maximum load-carrying capacity and is located on the port forward side of the trailer. The Gross Vehicle Weight Rating (GVWR) is the load-carrying capacity plus the weight of the trailer itself. DO NOT exceed the GVWR rating for the trailer.

**NOTICE**

When using or choosing a tow vehicle with the correct GVWR, you must consider not only the weight of the boat and trailer but also the weight of the fuel, water, equipment, etc. Refer to Table 1 below:

EQUIPMENT	WEIGHT (AVERAGE)
Battery	60 Lbs.
Fuel	6.5 Lbs./Gal.
Water	8 Lbs./Gal.
Accessories	150 Lbs. (Approximate)

*Table 1: Average Equipment Weight*

If selecting a trailer from another manufacturer, check the load-carrying capacity. A trailer with a load-carrying capacity that is too low will be unsafe on the highway and could cause sudden failure of critical trailer components or abnormal tire wear. A trailer with too high of a load-carrying capacity that is sprung for heavy loads can damage a lighter boat.

**NOTICE**

DO NOT overload your trailer by placing camping gear or other heavy equipment in the boat. DO NOT exceed the GVWR rating. Damage to the hitch, coupler, or trailer may occur.

Improper weight distribution can place excessive strain on the towing vehicle and trailer. It can also cause the trailer to “fishtail” (sway side to side). Be sure gear and other items are distributed evenly in the boat.

**C. Hitches**

The load-carrying capacity of trailer hitches will vary between manufacturers and must equal or exceed the GVWR. Four Winns® trailers use surge disc brake systems and require a fixed hitch. Refer to Section S-2E Surge Disc Brakes for more information.

Before hitching the trailer to the vehicle, make sure the proper size hitch ball is installed to match the coupler. The ball size is determined by the Gross Vehicle Weight Rating or GVWR. The GVWR is printed either on the trailer plate or embossed on the tongue, coupler or actuator. For trailers with a GVWR of 7000 pounds or less a 2” ball is used. For trailers with a GVWR over 7000 pounds a 2 5/16” ball is used. This information may also be obtained on our website at [www.fourwinns.com](http://www.fourwinns.com). Refer to Section S-3 Operation for additional information on hitches. Also, consult your Four Winns dealer for his recommendation before purchasing a trailer hitch for your towing vehicle.

 **WARNING**

To help guard against a sudden failure while in use, **do not use a worn hitch ball**. Replace all worn or damaged parts.

**S - 2 TRAILER COMPONENTS**

**A. Bunk Supports**

All bunk boards are made of pressure treated wood. This wood is rot resistant. All boards are covered with a high quality exterior grade carpet to protect the boat from damage during normal use.

Bunk supports run parallel to the keel and support the hull, extending beyond the transom. See Figure S1.

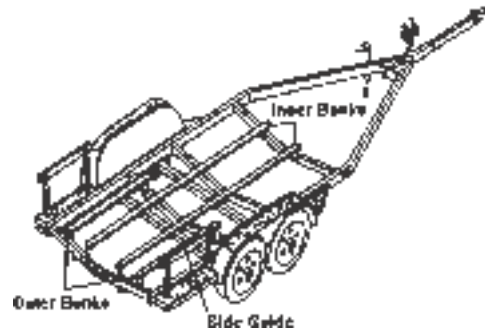

*Figure S1: Trailer Bunks*

Outer bunk supports provide stability for the boat. The inside bunks are the main weight bearing members. Side guide-on supports help to keep the boat straight while driving the boat onto the trailer. Keeping the tie-downs tightly fastened will prevent the boat from bouncing against the bunk supports.

**NOTICE**

Improper trailer setup can cause hull damage.

**B. Tongue**

Four Winns® trailers are designed with tongue weights between 5% and 10% of the total weight of the boat, fuel, gear and trailer. If the downward weight on the coupling ball does not fall within this range, coupler failure and towing instability may occur. If using another manufacturer’s trailer, have the dealer check the tongue weight before trailering.

**NOTICE**

DO NOT use a bent or damaged tongue or coupler. Replacement parts may be ordered through a Four Winns dealer.

The trailer tongue is hinged or removable on our painted trailers and galvanized trailers. This allows for easier storage. The tongue is attached with clevis pin(s) with locking hair pin(s) or clevis pin keeper(s) to the trailer frame. Refer to Figure S2.



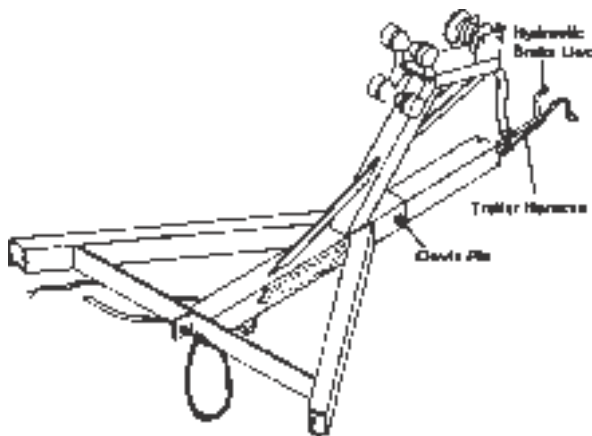

Figure S2: Trailer Tongue Assembly

To pivot the tongue on trailers models with hinge located inside the receiver:

1. Make sure the trailer jack is supporting the trailer load properly. Refer to Section S-2C on Swivel Jacks for additional information.
2. Unplug the wire harness at the trailer cross member.
3. Disconnect the brake line coupler.
4. Remove the locking hair pins and clevis pins. Please note, the locking hair pins must be rotated away from clevis pin and then removed.

**NOTICE**

The tongue will exert some pressure on the clevis pins. It may be necessary to lift, push or wiggle the tongue to remove the clevis pins.

5. Slide trailer tongue out of receiver until the hinge is exposed. Pivot the tongue towards the trailer as far as it will go.

To reinstall, follow this procedure in reverse order.

1. Pivot the tongue so that it extends straight and is in alignment with the receiver.

**NOTICE**

When extending tongue ensure that the brake line and wire harness are not pinched. Failure to check could result in damage.

2. Slide the trailer tongue into the receiver until the clevis pin holes are aligned.
3. Insert clevis pins with washers and locking hair pins.

**NOTICE**

The tongue will exert some pressure on the clevis pins. It may be necessary to lift, push or wiggle the tongue to insert the clevis pins.

4. Reconnect the brake line coupler.
5. If towing the trailer, remember to plug the 5-wire tongue harness to the trunk connector wire harness of your tow vehicle.

**CAUTION**

Make sure the trailer tongue is secure before hitching to the towing vehicle.

To pivot the tongue on trailers models with exposed hinges:

1. Make sure the trailer jack is supporting the trailer load properly. Refer to Section S-2C on Swivel Jacks for additional information.
2. Unplug the wire harness at the trailer cross member.
3. Disconnect the brake line coupler.
4. Remove the clevis pin keeper and clevis pin.

**NOTICE**

The tongue will exert some pressure on the clevis pins. It may be necessary to lift, push or wiggle the tongue to remove the clevis pins.

5. Pivot the tongue towards the trailer as far as it will go.

To reinstall, follow this procedure in reverse order.

1. Pivot the tongue until the clevis pin hole is aligned.

**NOTICE**

When extending tongue ensure that the brake line and wire harness are not pinched. Failure to check could result in damage.

2. Insert clevis pin. **Always** be sure to insert clevis pin from the top and insert the clevis pin keeper.

**NOTICE**

The tongue will exert some pressure on the clevis pins. It may be necessary to lift, push or wiggle the tongue to insert the clevis pins.

4. Reconnect the brake line coupler.
5. If towing the trailer, remember to plug the 5-wire tongue harness to the trunk connector wire harness of your tow vehicle.

To remove the tongue on painted or galvanized trailers:

1. Make sure the trailer jack is supporting the trailer load properly. Refer to Section S-2C on Swivel Jacks for additional information.
2. Unplug the wire harness at the trailer cross member.
3. Disconnect the brake line coupler.
4. Remove the locking hair pin and clevis pin. Please note, the locking hair pin must be rotated away from clevis pin and then removed.

**NOTICE**

The tongue will exert some pressure on the clevis pins. It may be necessary to lift, push or wiggle the tongue to remove the clevis pin.

5. Slide trailer tongue out of receiver and store in a proper place. If the trailer has brakes, store the tongue upright to prevent brake fluid from leaking.

To reinstall, follow this procedure in reverse order.

**CAUTION**

Make sure the trailer tongue is secure before hitching to the towing vehicle.

**C. Swivel Jack**

The jack is designed to lift, lower and support the tongues of the trailers when not connected to the towing vehicle. Before unhitching the trailer, use the following guidelines when setting up the jack.

1. Pull on the lock pin. See Figure S3.

2. Swivel jack to the vertical position.

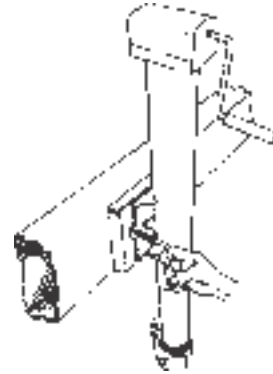

Figure S3: Swivel Jack

3. Release the lock pin and make sure the pin fully engages the attached tongue bracket.

**CAUTION**

Be sure dirt, sand, ice, etc., does not obstruct the proper seating of the lock pin.

4. When raising or lowering the jack, prevent the caster from rotating while cranking. Make sure the jack is planted on a firm and level surface before unhitching the trailer.

**WARNING**

To prevent personal injury or damage to the boat and trailer, observe the following:

- NEVER pull on the lock pin when any trailer weight is on the trailer jack.
- DO NOT move the trailer when resting on the swivel jack. Use towing vehicle to move the boat and trailer.
- Keep body and feet clear of trailer tongue when raising or lowering jack.

Always remember to swivel jack to the horizontal position before towing the trailer. Damage to the caster and jack may result.

The swivel jack provided on the Four Winns® trailer can be removed from the trailer to allow for maintenance or repairs. Follow the manufacturer's recommendations provided in the owner's packet.

### D. Coupling Assembly

To unlock the coupler, pull the locking trigger upward with your index finger and lift the locking lever. To lock, push the locking lever down. See Figure S4.

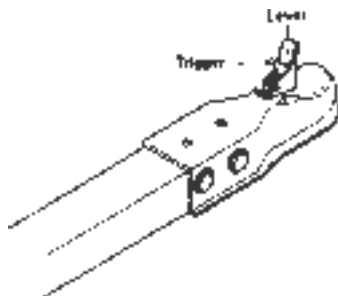

Figure S4: Coupling Assembly

This is also applicable to the Surge Disc Brake Actuator and Coupling Assembly.

### E. Surge Disc Brakes

Surge disc brakes are available on model trailers manufactured by Four Winns. Surge disc brakes operate automatically when the tow vehicle's brakes are applied. When the tow vehicle slows down or stops, the forward momentum or "surge" of the trailer against the hitch ball applies pressure to a master cylinder in the trailer coupler. The master cylinder supplies hydraulic pressure through the hydraulic system which activates the trailer's disc brakes. See Figures S5 and S6. Please refer to the manufacturer's literature included in your owner's packet for further details regarding operation and maintenance.

The benefits of disc brakes in comparison to drum brakes:

- Fewer moving parts.
- Longer life due to fewer moving parts.
- Friction pads are easily accessible.
- Easy access to caliper for cleaning and maintenance.
- Calipers are self-adjusting allowing smoother braking operation.
- Braking performance less likely to be affected by dirt, water, or rust contamination.
- Fade resistant.

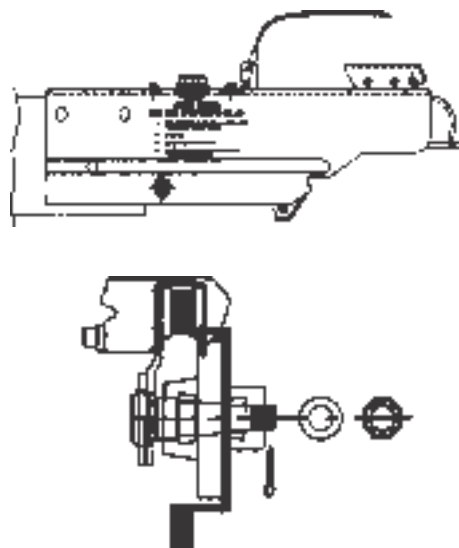

Figure S5: Brake Actuator & Coupling Assembly and Brake

For boat models with the Surge Brake Actuator and Coupling Assembly shown in Figure S6, lift the release handle to unlock the coupler. Push down on the release handle/locking lever to lock the trailer to the ball hitch. The locking pin, provided with the trailer, or a padlock **must be inserted** in the locking lever hole. This ensures the coupler's locking lever remains in the locked position during towing of the trailer. Refer to Section S-3 Operation for additional information on couplers and hitching to the tow vehicle.

#### NOTICE

Anti-sway devices as used on recreational vehicles (RV's) are not applicable to surge brake systems and should not be used on Four Winns® trailers.

DO NOT use a trailer hitch with moving parts. The brakes could activate when traveling downhill. Always use a fixed hitch.

If the brakes are wet from loading, travel at a slow speed and apply the brakes on your towing vehicle several times to "dry" out the trailer brakes.

Release handle must be in open position to remove from or place on ball.

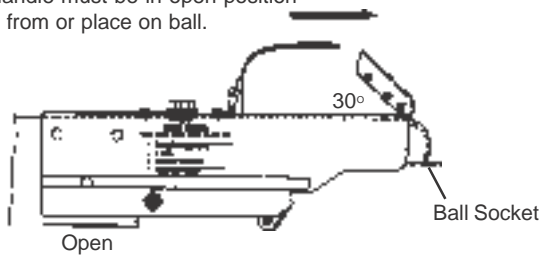

Release handle must be fully closed and pin inserted before towing.

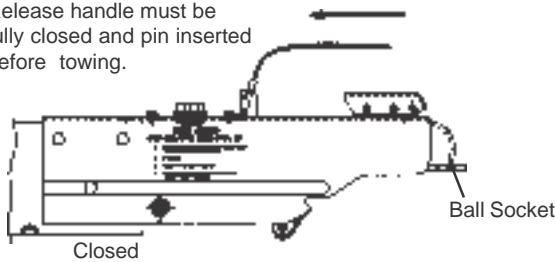

Figure S6: Surge Brake Actuator & Coupling Assembly

The brake actuator and coupling assembly comes with a 5-wire plug for connecting to the tow vehicle's trailering harness. Figure S7 depicts the 5-wire plug, the color of the individual wires, and the designated circuit for each wire.



Figure S7: 5-Wire Plug Harness

For maintenance and other information, refer to the manufacturer's literature included with in the owner's packet.

**F. Winch**

Winch operating instructions are listed below.

To release the winch, place the ratchet in the REVERSE or NEUTRAL position. The winch handle may spin when pulling on the winch line.

**CAUTION**

To prevent personal injury, observe the following:

A spinning winch handle can cause injury. Be sure the area is clear.

DO NOT release the handle when the ratchet is disengaged. Be sure the ratchet is engaged or no load is on the winch before releasing the handle.

**CAUTION**

To prevent personal injury, ALWAYS inspect the winch line and hook before each use. NEVER use line that is worn or frayed. NEVER let anyone stand in or behind a boat while pulling with the winch.

To rewind the winch, ALWAYS engage the ratchet first. Turn the handle in the appropriate direction to rewind the line.

**CAUTION**

A clicking sound will be heard when the winch is properly engaged. If a clicking sound is not heard, DO NOT release the handle. Handle may spin backwards. Lower the load into a safe position before releasing the handle.

Refer to the manufacturer's literature, included in the owner's packet, for more information on winch operation.

**G. Tires & Wheels**

Trailer wheel rims are available in three types of finishes: white, aluminum and galvanized. The white, powder coat finish is standard. Aluminum rims (Mags) are optional on painted trailers. Galvanized trailers are equipped with matching galvanized rims. Spare tire covers are available as an option and will match the trailer.

The tires installed on Four Winns® trailers meet the trailer load requirements for each model. Before trailering, make sure the tires are inflated according to the manufacturer's recommendation. Tire pressure information is noted on the tire and in the manufacturer's literature included in the owner's packet.

**NOTICE**  
**Carlisle Tire Registry**

Ensure to fill out your name and address on the tire registration form provided in your owners packet. Mail it to the tire manufacturer for the purposes of compliance with Federal defect notification regulations.

Mag wheels include a locking-type nut to help deter theft. This nut requires a special key or socket to remove. The socket will be included with your trailer when mag wheels are ordered. Refer to Figure S8.

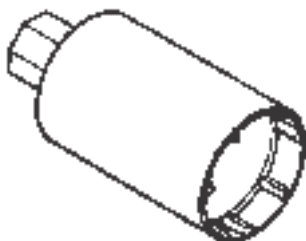

*Figure S8: Mag Wheel & Mag Wheel Key (Socket)*

**NOTICE**

DO NOT use an air wrench or other power equipment to install lug nuts on aluminum (Mag) wheels. Damage to the wheel may result. Lug nuts should be torqued to 85 foot pounds.

Examine the tires frequently for snags, bulges, excessive tread wear, separations or cuts.

Refer to the manufacturer's literature included in the owner's packet for more information.

**NOTICE**

The warranty of the tire is administered by the manufacturer of the tire. The manufacturer of the tires on your trailer is Carlisle Tire. Please call 1-800-260-7959 regarding any warranty concerns relating to your tires.

**H. Spare Tire Carrier**

Spare tires are optional on all Four Winns® trailers. A spare tire carrier is bolted to the trailer frame and is available in painted or galvanized finish. A spare tire carrier and wheel can be ordered from your Four Winns dealer. Refer to Figure S9.

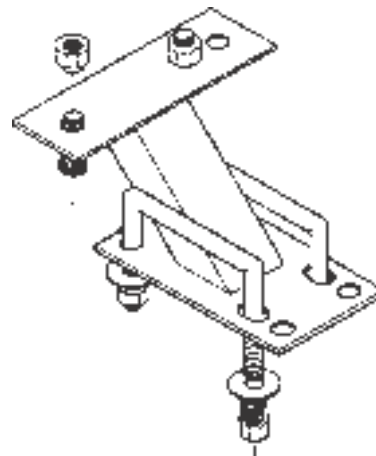

*Figure S9: Spare Tire Carrier*

**I. Lights**

Four Winns® trailers are equipped with taillights, brake lights, turning signals, and clearance lights. All lights are sealed to prevent moisture from entering. The taillight bulb and/or assemblies may be replaced. The bulb to the taillight is enclosed in a sealed housing which can be opened for bulb replacement. Contact your Four Winns dealer for assistance.

**NOTICE**

Use a heavy duty turning signal flasher on towing vehicles. Check with your local auto parts store or ask your Four Winns dealer for assistance.



Consult your dealer for state trailer regulations concerning lighting and other optional equipment.

**J. Tie-downs**

The boat should be secured to the trailer by tie-downs to prevent damage to the hull. The boat may shift or bounce against the bunks or hull supports if not secured. It may also slide or fall off the trailer while being towed.

There are two types of tie-downs being used:

1. Bow Tie-downs: A bow stop to hold the front of your boat in place is located on the winch stand. It should be positioned so that the winch line pulls straight and is parallel to the trailer frame. A separate tie-down should then be attached to hold the boat. See Figure S10.

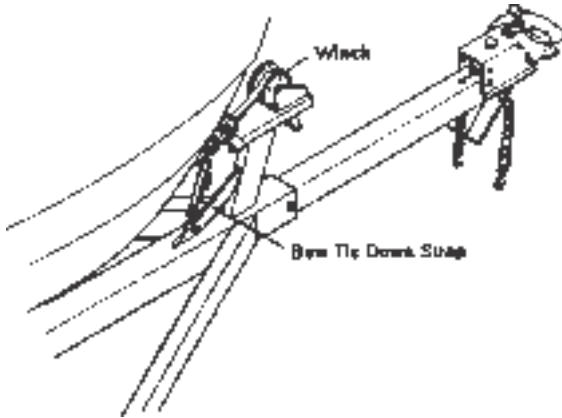
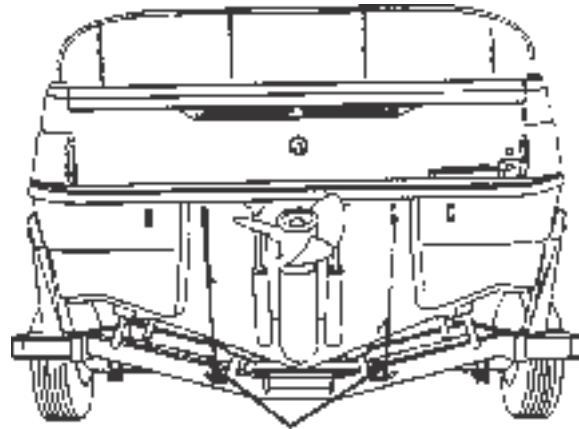

Figure S10: Bow Tie Down Strap

**NOTICE**

DO NOT rely on the winch cable (or line) alone to hold the bow of the boat against the bow stop. A bow tie-down is provided with the Four Winns® trailer.

2. Rear Tie-downs: It is very important that the transom is resting securely on the bunk supports at the rear of the trailer. Rear tie-downs are provided to secure the boat to the trailer. Tighten the tie-downs to prevent the boat from moving. See Figure S11.



Rear Tie Down Straps

Figure S11: Rear Tie Down Straps

The tie-down is a mechanical ratchet device. To allow line out, follow the procedures below:

1. Place two fingers on spring-loaded release, and pull release away from spindle/gear.
2. Open tie-down to a flat, 180° position.

**NOTICE**

Spring-loaded release should click into a notch on the painted handle. Both spring releases should clear the inner gear.

3. Pull line out. The inner spindle/gear should move freely.

To ratchet line or tighten down the strap on the boat:

1. Place two fingers on spring-loaded release, and pull release away from spindle/gear.
2. Bring both handles together. Both handles should ride on the inner gear.
3. Open (to approximately 110°) and close handles to ratchet. Leave in closed position to maintain pressure on line.

S - 3 OPERATION

A. Hitching Trailer

Before towing, the trailer must be properly hitched to the tow vehicle.

**WARNING**

To ensure proper engagement of the actuator's coupler to the tow ball, **DO NOT** use a multi-piece ball, an incorrectly sized ball, or a worn/damaged ball. Please refer to the trailer's certification plate, coupler or actuator on the trailer for Gross Vehicle Weight Rating (GVWR) or visit our website at [www.fourwinns.com](http://www.fourwinns.com). Trailers with a GVWR of 7000 pounds or below require a 2" tow ball and trailers above a GVWR of 7000 pounds require a 2 5/16" tow ball.

1. Position actuator ball socket above ball hitch.
2. Lift up on release handle fully (approximately 30° for a trailer with brake actuator and coupler assembly) to allow the ball latch to rotate open. The handle will remain up to indicate that it is not yet attached to the ball. See Figure S6.
3. Lower trailer tongue until ball is seated or rests in ball socket.
4. Close release handle. If it is a trailer with brake actuator and coupler assembly the handle will snap to its closed position when properly seated.

The release handle will close freely with finger pressure when ball is properly seated in socket. **If the handle does not close freely or does not snap to its closed position properly, do not tow trailer. DO NOT** force handle into closed position, otherwise damage could result. Inspect actuator for bent parts or cause of improper operation.

**NOTICE**

Keep the coupler clean and lubricated to prevent damage to the coupler.

5. Make sure the actuator is secure. If unsure, extend the trailer tongue jack to the ground and lift (with the jack) the car and trailer combination approximately 2" to 4". If the ball does not disengage and remains secured, the actuator is latched properly.

**NOTICE**

To prevent back injury, **DO NOT PHYSICALLY LIFT** the trailer tongue when loaded.

6. The locking pin, provided with the trailer, or a padlock **must be inserted** in the locking lever hole. This ensures the coupler's locking lever remains in the locked position during towing of the trailer. Use of a padlock will help to deter theft.
7. Connect break-away cable S-hook securely to one of the tow vehicle hitch's safety chain connection points. The cable should hang clear of trailer tongue and be long enough to permit short radius turns without pulling break-away cable forward. **DO NOT** loop the break-away cable around a bracket and loop it back onto itself.
8. Make sure the break-away lever is fully rotated to the rear with the break-away catch pin securely located under the break-away spring. The break-away catch pin will be in the lever's uppermost notch. See Figure S12.

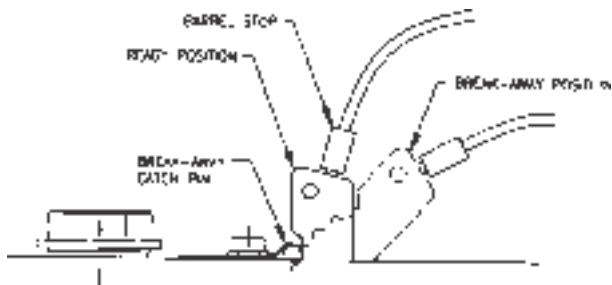

Figure S12: Break-away Cable

**CAUTION**

The Break-away system is not designed to operate if the trailer does not separate completely from the tow vehicle, or if the trailer tongue "submarines" and goes beneath the tow vehicle. **DO NOT** use break-away cable as a parking brake.

9. Safety chains or cables (depending on which model you have) are provided and must be used. Cross the safety chains/cables under the coupling and attach to the towing vehicle's frame or bumper. See Figure S13. Always allow slack for turns. Four Winns provides securement clips for the safety chain/cable hooks and recommends you use them. Regulations vary from state to state. Please check the local laws in your state.

**WARNING**

The trailer's safety chain/cable length **MUST** be set short enough so the actuator's break-away cable is **NOT** pulled if the coupler separates from the tow vehicle's hitch but remains connected by the safety chains/cables. The break-away system should only be activated after **BOTH** the trailer's coupler and safety chains/cables have failed and allowed the trailer to completely separate from the tow vehicle. Provide just enough slack in the trailer safety chains/cables to allow short radius turns. The chains/cables should not drag on the ground. **Safety chains/cables must be used.**

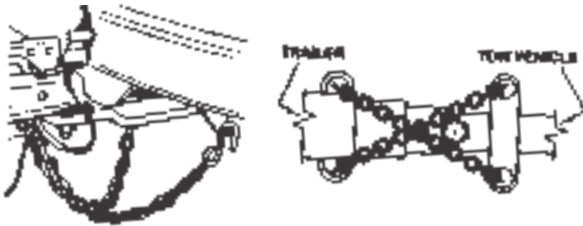

Figure S13: Crossing the Safety Chains/Cables

**WARNING**

To reduce the risk of Break-away accidents, be sure coupler is seated and safety chains/cables crisscrossed before trailering.

**NOTICE**

Rubber safety chain straps are included on the "S" hooks to prevent chains/cables from bouncing off of the tow vehicle and **must be used.**

10. Retract jack fully and place in trailering or horizontal position.
11. Check for proper tow vehicle-trailer hookup. The tow vehicle and trailer should be level with a positive tongue load. Four Winns® trailers are designed with tongue weights between 5% and 10% of the total weight of the boat, fuel, gear and trailer. The trailer should be close to level. If unsure of tongue load and trailer position, consult your Four Winns dealer before proceeding.

**WARNING**

Be sure the tow vehicle and trailer are level and have a positive tongue load. This will allow the brake actuators to function properly on trailer models having such braking systems.

Be sure to read the manufacturer's literature, included in the owner's packet, before towing your Four Winns® boat and trailer.

**B. Backing Up With Surge Disc Brakes**

Follow the steps listed above for hitching the trailer before backing up.

1. Before backing up a slope or through soft ground, pull the trailer forward slightly to assure the actuator socket is in the fully forward position.
2. Back the trailer up.

**CAUTION**

Avoid sharp turns. This could bend, create extreme stress or fracture either the actuator or trailer tongue.

**NOTICE**

Be sure to check for obstacles or persons behind the trailer before backing up. Also, adjust your mirrors for clear view of the area behind the trailer.

3. If the trailer is to be uncoupled from the tow vehicle after backing, block all trailer wheels and pull forward slightly to take strain off the actuator.

Uncouple the actuator by lifting the release handle and raise the trailer tongue with the jack.

For most trailering conditions, the brake actuator will allow you to back up normally. However, if the coupler is not wired or if there is a failure the trailer can still be backed up by using the manual brake lockout.

To use your lockout, check that no force is being applied to the actuator. This is achieved by positioning the towing vehicle and the trailer on a flat service, or with the trailer downhill from the tow vehicle. Set the vehicle's parking brake.

Rotate the lockout assembly forward and up. See Figure S14. Then push it rearward, so the pin ends will rest in the notches in the sides of the outer case. The actuator is now “locked out” and will not apply any noticeable pressure to the trailer brakes as you back up. If you can not rotate the assembly forward enough to reach the notch, make sure the actuator’s coupler case assembly is pulled fully forward out of the outer case.

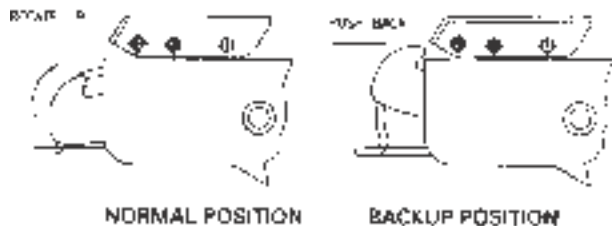

Figure S14: Brake Lockout Mechanism

**NOTICE**

Trailer components may be different between models and may change during the model year. Be sure to read all manufacturer’s literature supplied with your Four Winns® trailer.

**S - 4 TRAILERING**

**A. Checklist**

Before trailering, the trailer should be inspected for the following:

1. Check tires for proper inflation. Under-inflated tires heat up rapidly and may blowout or cause uncontrolled swaying. Also, make sure lug nuts are tight.
2. Be sure the coupler is secured to the trailer hitch and safety chains are attached.
3. Be sure trailer taillights and turning signals are operational.
4. Check the brakes for proper operation prior to departure.
5. Check lug nuts for proper tightness.
6. Check tie-downs and make sure boat is secured to the trailer.
7. Check the springs and under carriage for loose parts.

8. Before towing, close and secure all hatches, doors, and windows. Securely store all equipment and canvases. Installed tops, side curtains, and aft curtains can be damaged while towing.
9. Carry a spare tire for both the trailer and towing vehicle. On extended trips, carry spare wheel bearings, seals, and races. Be sure and carry the proper tools to complete the repairs.

 **WARNING**

To avoid bearing failure and possible wheel loss, keep wheel bearings properly lubricated. Inspect the wheel bearings periodically and check for damage.

10. Before trailering, inspect the bearings for wear and adequate lubrication. When traveling, check the wheel hubs during stops at gas stations, restaurants or other places. If the hub feels abnormally hot, the bearing should be inspected before continuing the trip.

**B. Tactics**

**NOTICE**

Be sure to check the towing vehicle manufacturer’s literature for recommendations on towing.

1. Install outside rear view mirrors on both sides of the towing vehicle to improve vision. Check the rear view mirrors at frequent intervals to be sure trailer and boat are riding smoothly.
2. Allow at least one car and trailer length between vehicles for each 10 mph. **DO NOT** tailgate.
3. Use low gear (on manual transmissions) when traveling up steep hills or over sand, gravel, or dirt roads.
4. Use care if shifting to a lower gear while traveling downhill. This could activate the trailer’s surge brakes for the duration of the downhill run and cause overheating. Extended overheating could result in complete loss of the trailer brakes.

To help prevent overheating, slow down while approaching the crest of a hill and maintain a slow, controlled downhill speed. Apply brakes in short intervals to allow time between braking for the brakes to cool off.

5. When rounding turns on highways or streets, **DO NOT** cut corners. Also, travel slowly over railroad tracks.

6. If the trailer begins to “fishtail” when accelerating, reduce speed until it ceases. If the trailer “fishtails” again during acceleration, stop to investigate the cause of the problem. Check for improper trailer load and uneven weight distribution inside the boat. Check the winch line and tie-downs. Also check the tires for proper inflation or damage. If necessary, redistribute the load before continuing.

For additional information on trailering, refer to the “Boating Basics” manual included in the owner’s packet.

## S - 5 MAINTENANCE

### A. Care of Exterior Finish

When using the trailer, keep in mind the paint can scratch and become marred during normal use. In most cases, touch-up paint can be ordered. Please contact a Four Winns dealer for assistance.

Some maintenance is required to maintain the finish and minimize rusting. The trailer should be washed and rinsed with clean water immediately after each use. On galvanized trailers, rinse only with clean water. Depending upon use, waxing is recommended twice a year. Use paste wax designed for enamel paint.

### B. Bunks

The bunks should be replaced if they are cracked, warped, or evidence of dry-rot is found. The replacement boards should be treated lumber of the same length and width.



#### CAUTION

DO NOT burn damaged or broken bunks. Toxic fumes will be released. Dispose of bunks properly.

### C. Swivel Jack

Keep the swivel jack clean of dirt, tar, and mud. Lubricate every six months. The swivel jack’s inner ram should be lubricated with SAE 30 weight oil. The top cover may be removed to lubricate the gears with wheel bearing grease.

Replace all worn and damaged parts. ALWAYS use the manufacturer’s replacement parts. Replacement parts may be ordered through your Four Winns dealer.

For more information on maintenance, refer to the manufacturer’s literature included in the owner’s packet.

### D. Brake Actuator & Coupling Assembly

When storing or parking your trailer, keep the brake actuator and coupling assembly (coupler) off the ground to prevent dirt buildup in the ball socket. Keep the coupler clean of dirt, tar, and mud. Lubricate the coupler with SAE 30 weight oil every six months or as often as necessary. Replace any worn or defective parts. If the coupler is damaged, contact your Four Winns dealer for replacement parts. DO NOT use a damaged or bent coupler assembly.

For more information on maintenance, refer to the manufacturer’s literature included in the owner’s packet.

#### NOTICE

The trailer should be set up at a slight angle to allow for water to drain aft in the boat.

### E. Winch

The winch should be kept clean of dirt, ice, paint, etc., and the spur gears should have a film of grease on them at all times. Apply several drops of SAE 30 weight oil to the ratchet pawl mechanism, bushings and pinion shaft threads twice per season.

Replace any worn or damaged parts. For more information on maintenance, refer to the manufacturer’s literature included in the owner’s packet.

### F. Lights

Inspect wiring for cuts or bare wire which could cause electrical shorts. Repair or replace defective wiring. Replace cracked or damaged lens and always carry spare bulbs. Replacement parts may be ordered through a Four Winns dealer.

### G. Tie-downs

Replace frayed or damaged tie-downs. Periodically, lubricate the ratchet mechanism with a fine oil or silicone spray. Replacement parts may be ordered through a Four Winns dealer.



## H. Wheels

Some maintenance is required to maintain the finish and retard rusting of painted rims. The wheels should be cleaned with dishwashing soap and water and rinsed with clean water immediately after each use. Waxing is recommended three to four times each year.

Aluminum wheel rims may be cleaned with dishwashing soap and water. However, cleaning products specifically for aluminum are available and can be used. Cleaners may be obtained from Four Winns dealers and your local auto parts stores. The Mag wheel manufacturer recommends a product by Priority One® called Pro-Long Aluminum/Chrome Wheel Protectant™. Galvanized rims should be rinsed only with clean water immediately after each use.

### NOTICE

ALWAYS read the manufacturer's instructions on the label before using any product.

## I. Brakes

Keep the actuator clean of dirt, tar, and mud. The actuator and internal parts should be lubricated at all times with SAE 30 weight oil. The hitch ball may be lubricated with automotive grease or lubricant made for hitch balls.

Periodically inspect the brake system for leaks. Check all hoses for cuts or wear. Replace all defective hoses. The master cylinder should be filled within 1/2 inch from the top of the reservoir.

At the beginning of each year, inspect the brakes for excessive wear, have linings replaced if necessary.

If the brakes need bleeding, consult your Four Winns dealer for assistance. If unavailable, a brake or auto repair facility can perform the repair.

Refer to the manufacturer's literature included in the owner's packet for additional information on the brake system.

## J. Bearings

Wheel bearings and seals should be inspected at the same time as brakes. Have worn or defective parts replaced. Grease bearings and seals at this time and at the end of the boating season. Bearing Protectors should be greased three to four times a year. A grease fitting is provided.

Four Winns uses the Accu-Lube™ bearing protection system on its trailers. The Accu-Lube™ design is submersible and provides for grease flow that completely repacks and protects the bearings. This lubrication system disallows water entry, thus extending the life of the bearings, spindle and hub.

Lubricate the bearings as follows:

1. Remove the rubber plug.
2. Insert the grease gun into the grease fitting. Pump grease until old grease comes back out the front.
3. Remove old grease and reinstall rubber plug.

### NOTICE

Most bearing failures are due to improper maintenance. Be sure to inspect bearings and seals as noted in Section S-6B and refer to the manufacturer's literature included with your trailer.

## S - 6 AXLE INSPECTION & REPAIRS

As a general rule, repairs and maintenance should be performed by qualified servicing personnel. Our axle manufacturer recommends that a certified mechanic should be consulted on the following items:

1. Broken axle
2. Broken spring
3. Worn spring eye bushing parts
4. Sagging springs
5. Welding fatigue
6. Serious leakage of seal
7. Tire wear
8. Loose or worn suspension parts
9. All brake related adjustments, inspections and problems

### A. Removal of Hub

The following instructions pertain only to trailers manufactured by Four Winns. To remove the hub to inspect the bearings and seals, refer to Figure S15 and the following instructions:

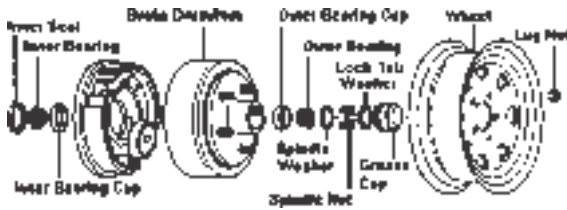

Figure S15: Axle Components

1. Remove lug nuts.
2. Remove wheel.
3. Remove grease cap.
4. Remove lock tab washer.
5. Unscrew the spindle nut counter clockwise.
6. Remove spindle washer.
7. Remove hub from spindle.

**B. Bearing/Seal Inspection and Replacement**

When inspecting bearings or seals:

1. Inspect the grease seal for damage, tears, or cracks. If there is no damage or leakage is not occurring, the seal is in good condition.  
  
If the seal is torn or cracked, then it should be replaced. The seal can be pried out of the hub with a screw driver. Be sure to replace the seal using the recommended replacement parts. Parts can be obtained from your Four Winns dealer.
2. When inspecting the bearing, check for corrosion and wear. If any rust or wear exists on the bearing, then remove and replace with the recommended parts listed in the table above.
3. If the bearings are in good condition, repacking the grease should be done at this time. Hand pack each bearing individually using a premium water resistant wheel bearing grease

**C. Hub Reinstallation**

1. To reinstall hub, reverse the procedures listed above.
2. It is important to tighten the spindle nut to approximately 50 ft. lbs. (12" wrench with full hand force). Loosen the nut then finger tighten.
3. Replace the cotter.
4. When reinstalling wheel, the following tightening procedure is recommended by the manufacturer:
  - a. Place wheel lug nuts on by hand to start.
  - b. Tighten initially to 15 - 20 ft. lbs. (Apply 20 pounds of pressure to wrench 12" long) using cross tightening sequence. Proceed to finish tightening to 85 ft. lbs. (Applying 85 pounds of pressure to wrench 12" long will yield 85 ft. lbs. of torque).
  - c. Re-torque after first 50 miles of use.

Refer to Section S-2G for additional information on wheel requirements.

# PRE-LAUNCH AND UNDERWAY

## T - 1 LAUNCH AND CRUISE CHECKLIST

- Get a current weather report. If the weather will not be favorable, postpone your trip.
- If your boat has been out of the water, check to see that all bilge water has drained out.
- Install hull drain plugs.
- Inspect the hull and propeller for damage. Excessive dirt or marine growth will effect your boat's performance and fuel efficiency.
- Check the electrical system and navigation lights.
- If your boat has been in the water, run the bilge pump until the flow of water stops.
- Check that all required safety equipment is on board and in good working condition. Examples include personal flotation devices (PFDs), horn, fire extinguisher, visual distress signals, etc. Take along a gallon of drinking water.
- Check that other important equipment is on board. Examples include mooring lines, anchor and line, tool kit, first aid kit, etc.
- Open engine compartment. Inspect for fuel odors and visible leaks in the fuel, oil, coolant, exhaust and power steering systems.
- Visually inspect engine for cracked hose, defective belts, or other signs of engine problems. Check engine oil and battery water levels. Check power steering fluid level. Check battery electrolyte range.
- Check fuel level. Fuel tanks should be filled to slightly less than capacity. Allow for fuel expansion.
- Check that all engine drains are closed (stern drives).
- Make sure navigation charts and equipment are on board.
- Check operation of steering system, navigation lights, and operation of horn.
- Make sure passengers and crew know what to do in case of an emergency and how to operate safety equipment.
- Make sure all required documents are on board.
- File a float plan with a responsible party ashore.
- Keep an eye on the weather. Be aware of possible changing conditions by monitoring local weather broadcasts prior to departure. The captain or first mate should personally monitor strong winds and electrical storms.
- Always keep accurate up-to-date charts of your boating area on board.

## T - 2 FUELING



Do not smoke, extinguish all open flames, STOP all engines and other devices that could cause sparks, including the bilge blower. Do not use electrical switches or accessories. Shut OFF all stoves that may produce a spark or flame. Close all openings into the cabin area of the boat.

### A. Recommendations



When fueling or having your boat fueled by an attendant, be sure the waste pump-out or fresh water fitting is not mistaken for the gas fill.

Although alcohol boosts the octane level of gasoline, it also attacks the rubber fuel distribution lines and even metal fuel system components. Alcohol will permeate most fuel hoses and other components such as fuel pump, gaskets and seals, and can also contribute to fuel system contamination.

The hoses we use in our boats are alcohol-resistant as are the materials used by the engine manufacturers. If only fuel containing alcohol is available, or the presence of alcohol is unknown, you must perform more frequent inspections for leaks and abnormalities. Any sign of leakage or deterioration requires your immediate attention. Refer to the engine manufacturer's recommendations on fuel type and octane ratings.

### B. Preliminary Guidelines

1. Safely secure your boat to the dock.
2. Close all hatches, windows, doors and compartments to prevent accumulation of fuel vapors.
3. Ensure that a fire extinguisher is readily available.
4. Do not store fuel in areas that are not adequately ventilated.
5. Use only fuel lubricants recommended by the engine manufacturer.

## C. Pumping Fuel



Follow engine manufacturer's recommendations for types of fuel and oil. Use of improper products can damage the engine and void the warranty.

1. Be sure to fuel in a well-lit area gasoline spills are unnoticeable under poor lighting or in the dark.
2. Remove the gas fill cover.
3. Insert the fuel supply nozzle, keeping it in contact with the fuel fill plate to guard against static produced sparks.
4. Stand away from the fuel tank vent and gas fill during fueling. Splashback may occur and can be an eye irritant and/or a fire hazard.
5. Avoid spillage. Wipe up any excess fuel immediately.
6. After pumping approximately 10 gallons of fuel into the fuel tank, inspect the engine and fuel tank area for any signs of leakage. If no leaks or other problems are detected, resume fueling.
7. Allow space at the top of the tank for thermal expansion.
8. If fuel cannot be pumped in at a reasonable rate, check for fuel vent blockage or a kink in the line.

### D. After Fueling

1. Replace the gas fill cover and wipe up any fuel spilled. Discard rags used in a safe place ashore.
2. Open the engine compartment and all hatches, windows, doors and other compartments that were closed during fueling. Inspect these areas for the odor of fuel vapors and visible fuel leakage.



Investigate and correct any sign of fuel leakage or indication of vapors before starting engine. Do not run blower or operate any electrical switch until problem is corrected. Fire or explosion may result.

**T - 3 LOADING PASSENGERS AND GEAR**

**NOTE:** All boats under 20 feet in length must have a capacity rating plate showing the recommended person capacity as well as the maximum capacity of the boat including persons and gear.

When loading your boat, remember to distribute the load evenly. Keep the load low and do not overload. The capacity plate affixed to your boat states the maximum load capacity. The plate shows in pounds, the amount of persons and gear that the boat will safely handle under normal conditions. U. S. Coast Guard regulations establishes these load capacity ratings. Position passengers and gear so that the load is balanced.

When loading, always step into the boat, never board by jumping. Have someone on the dock pass your gear aboard. Secure all gear firmly so it doesn't move or

interfere with operation of the boat. Passengers should board the boat one-at-a-time and be seated. Passengers should remain seated during loading of the boat to maintain an even trim.

 **WARNING**

**Passengers seated in the bow area should not obstruct the driver's vision.**

**IMPORTANT:** Passengers are prohibited from riding on the bow with feet hanging over the side or ride while sitting on the stern, gunwales or seatbacks. The Coast Guard considers these acts to be negligent or grossly negligent operation. They are prohibited by law because falls from moving boats are a major cause of fatal recreational boating accidents.

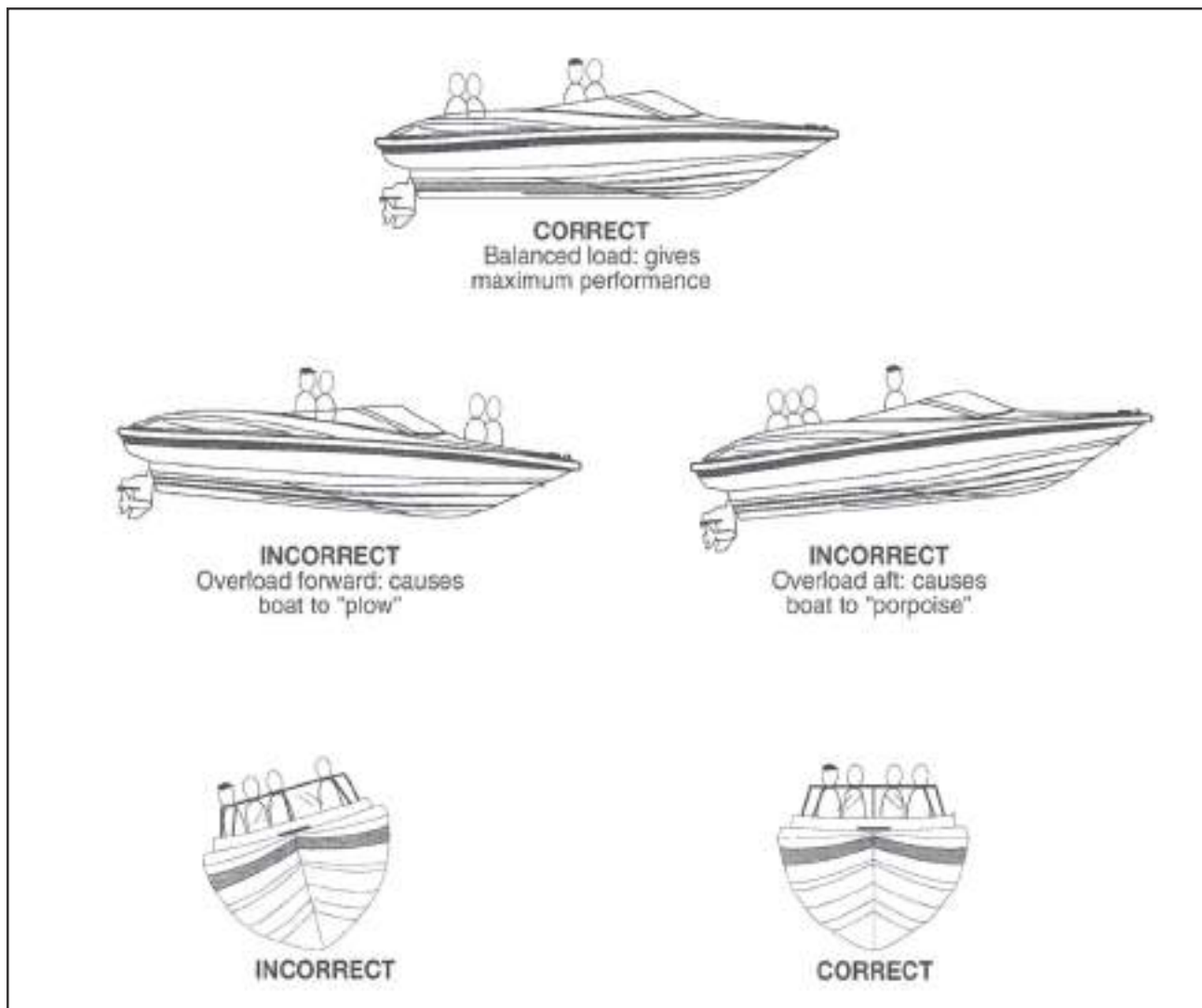

Figure T1: Loading Passengers and Gear



**IMPORTANT:** The presence of the capacity plate does not relieve the boat operator from the responsibility of using common sense or sound judgment. Turbulent waters and adverse weather conditions will reduce the maximum load capacity rating of the boat.

## T - 4 STARTING PROCEDURES

The operation and maintenance manual supplied with your engine provides pre-start, starting and cold-starting instructions. The following information is merely a guide and not intended to explain in detail all starting procedures and instructions. Refer to your engine owner's manual.

### A. Preliminary Checks

1. Secure boat to the dock before attempting to start engine. The boat should be kept secure until the engine is running and warmed up.
2. Operate the bilge pump until the flow of water stops.
3. Make sure the throttle is in the neutral position and stern drive or outboard is lowered into water.
4. Make sure passengers seated in the bow area do not obstruct the driver's vision.

### B. Starting



To prevent excessive exposure and reduce the possibility of carbon monoxide accumulation in the cockpit areas of the boat, the operator should provide adequate ventilation in each of these areas. Utilize hatches, doors, windows and side vents to increase air movement. See Section B-2 for information about the dangers of Carbon Monoxide.

**Notice:** Additional starting information is located in Section A.

1. Check all electrical systems and navigation lights.
2. If your boat is equipped with an optional battery selector switch, turn the battery switch to 1, 2, or BOTH or ON or EMERGENCY START ONLY position (depending on which model you have.)

3. Attach the ignition interrupt lanyards securely to your body. In the event that you move away from the helm area and beyond the length of the lanyard, the engine will be turned off.
4. If your boat has fuel injection, turn the key to start the engine. Engine will not turn over if throttle is not in the neutral position.

If your boat does not have fuel injection, depress the engine warmup button to advance the throttle several times and leave it in the SLOW/START position. This will actuate the carburetor accelerator pump and feed fuel to the engine. Turn ignition key to START position.

5. When engine is cold, run engine approximately one (1) to two (2) minutes at fast idle speed (1200 to 1500 rpm). This step is not necessary with fuel injected engines.
6. Once engine has warmed up, check water temperature gauge to ensure engine temperature stays within optimum range. If temperature reading is abnormally high, stop engine immediately and inspect for cause of high reading.
7. With engine running, voltmeter should show a reading between 12 and 15 volts.
8. Check steering operation. Turn steering wheel full to port and starboard while observing outdrive movement.
9. Inspect for fuel odors and visible leaks in the fuel, oil, coolant, exhaust and power steering systems.
10. Make sure boat is securely moored to the dock and engine is idling. Then move the throttle forward and then aft and back to neutral to check for proper operation of the shifting motion. Be careful. Leave the engine in gear for only a second or two.

## T - 5 MANEUVERING



Boat steering is not self-centering. Steering is effected by engine and propeller torque, trim tab setting, wave and current action and the speed of the hull through the water. Constant attention to steering is required for safe operation.

When all your pre-departure checks have been completed and the engine has warmed up, you will be ready to leave the dock. Take into account the amount of wind, tide current, and other forces that may affect your maneuvering as you leave the dock. Idle speeds work best when maneuvering to and from the dock. Do not forget to release the mooring lines.

### A. Leaving the Dock

You are ready to leave the dock after the engine has warmed up. Check all gauges for appropriate readings before casting off. If oil pressure is abnormally low or engine temperature is abnormally high, stop the engine immediately. Check voltmeter to be sure the charging system is working properly. Check for fuel, oil, and exhaust leaks. Correct the cause of any abnormal condition before getting underway.

 **WARNING**

Make sure passengers sitting in the bow area do not obstruct the operator's vision when casting off or while underway.

After making sure your boat is ready, check wind, tide, current and other forces that will affect the way you maneuver your boat away from the dock. Throw mooring lines off to your boat. Shift your boat's engine into forward or reverse depending on whether you want to move the bow or the stern away from the dock first. Run your engine at a slow speed as you move away from the dock. If you move the bow out first, watch that the stern of the boat does not swing into the dock or a piling.

Once away from the dock, devote some time to learning how to maneuver. Practice docking using an imaginary dock. Practice stopping and reversing.

### B. Stopping

Boats have no brakes. Stopping is accomplished by backing down on the throttle. Practice stopping maneuvers and learn early how your boat reacts. From forward motion, pull the throttle back towards NEUTRAL. Depending on your speed, the distance the boat travels until it comes to a complete stop will vary. The ability to measure the distance will only be acquired through experience.

Once the boat has slowed and motor is idling, place the shift in REVERSE. Gradually increasing reverse power with the throttle will allow you to stop the boat in a very short distance.

**NOTE:** A boat will not respond to steering in reverse nearly as well as it does when going forward, so do not expect to accomplish tight turning maneuvers when backing up.

Remember that all boats steer by the stern (the feeling is much like steering your automobile in reverse). This means that the stern of your boat will swing in the direction opposite to your turn. For example, when you turn the helm wheel to the left, the stern of your boat will swing in the direction opposite to your turn. This is especially important to keep in mind when docking, operating in close quarters with other boats, or when approaching a swimmer or downed skier in the water.

Always look behind you and to both sides of the boat before slowing down. Tell your passengers your intentions to allow them time to make adjustments to their balance or positions.

Slowly pull back on throttles, glance back and see if a large following wave is approaching the transom. If so give the engines a little throttle as the wave arrives to keep wave from rolling over the transom.

Once you have spent enough time practicing maneuvers and have a feel for how the boat handles, you will be ready to run in open waters.

## T - 6 ACCELERATION

 **WARNING**

Before accelerating to bring you boat on plane, be sure that the area in front of your boat is clear. The bow will rise out of the water momentarily before you plane and may temporarily obstruct your vision.

If you have never had your boat on plane before, choose a calm day for your first on plane experience. Never boat beyond your ability and experience.

Before bringing your boat "on plane", check the entire area to make sure you have a clear, safe path. As you throttle up to accelerate, your boat will increase its angle of trim, causing the bow to ride high. From a maximum angle, the boat will level out to its planing attitude with

continued acceleration. This maximum angle is known as the “hump”. Because visibility, handling, and performance are reduced, it is advisable to get “over the hump” as soon as possible. A few seconds at full throttle should get the boat over the hump and into its planing attitude.

After getting over the hump, accelerate until reaching a comfortable plane, then throttle down to cruising speed. This also will provide for better fuel efficiency.

**T - 7 TRIMMING YOUR BOAT**

**A. Trim Tabs**

Trim tabs are used to add lift to the boat’s stern, thereby changing the boat’s attitude (see Figure T2). This lift can help the boat get on plane faster and remain on plane at slower speeds than if no tabs were used. Used independently, tabs can also correct listing conditions caused by crosswinds, unbalanced loading and quartering seas. Trimming your boat properly involves two separate procedures, trimming or tilting the lower unit and setting the trim tabs.

When you are sitting dead in the water, your drive should be down and the trim tab switches are in the BOW UP position. Accelerate until you get onto plane. At this

point your boat will be plowing through the water with the bow down too far. Trim the lower unit up slightly until the bow comes up. If you trim the lower unit out too far, your boat will porpoise or the propeller will cavitate, and the bow will slam up and down on the water. Your boat is trimmed correctly when it is just short of porpoising or propeller cavitation, under ideal running conditions.

Trim your boat to compensate for seas, winds, or uneven loads.

Head Seas	Trim drives in more than usual. Use tabs to keep bow down and go at a slower speed.
Following Seas	To prevent taking seawater over the bow, trim drives out and keep tabs up to keep bow up.
Listing Due to Quartering Seas, Beam Wind, or Uneven Load	Use tabs independently to adjust for list. If listing to starboard, press port bow down switch. If listing to port, press starboard bow down switch.

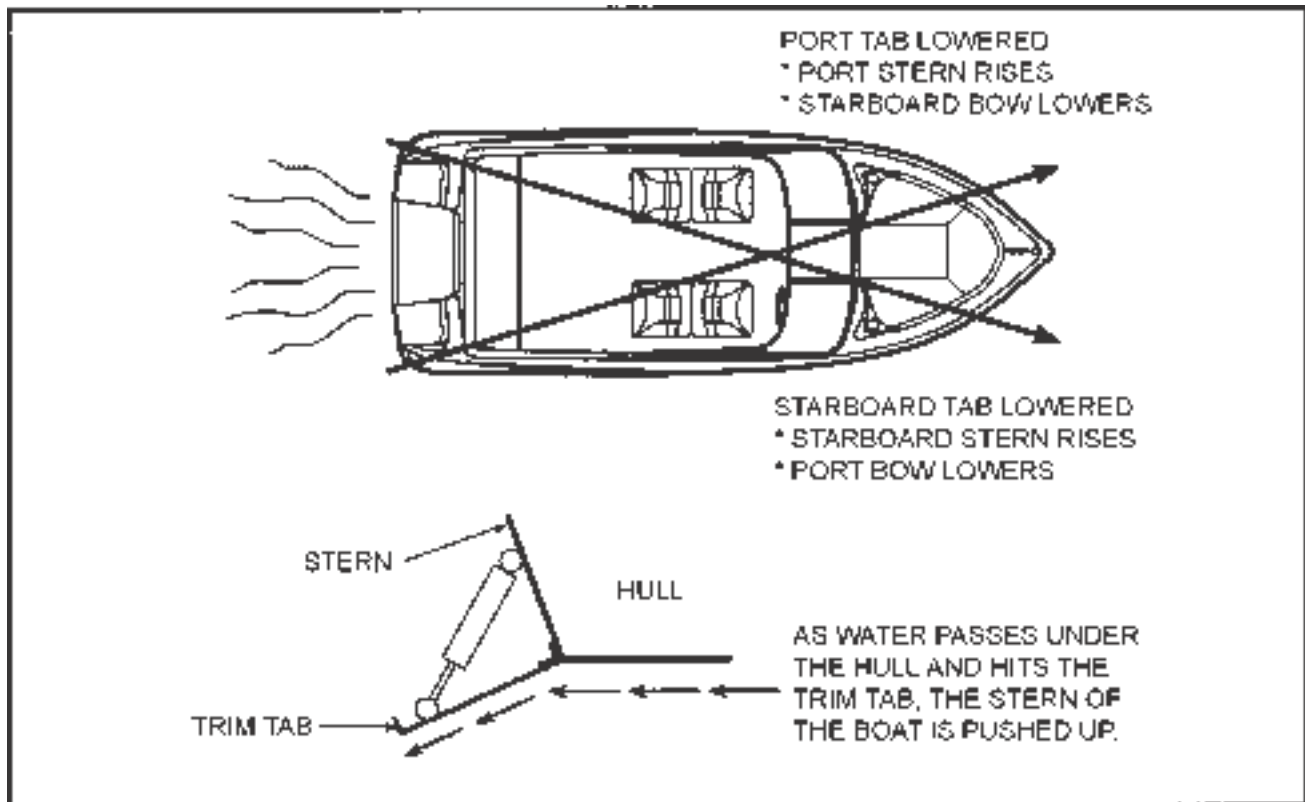

Figure T2: Trimming the Boat with Trim Tabs

Remember that most boats react very slowly to trim tabs. Often boat owners do not give trim tabs time to work. Press the trim tab switches for only one second at a time and then allow some time for the boat to react. If the boat is still listing after a minute or two, press the trim tab switch again for a one second interval. The labels on the trim tab switches indicate what you want your boat to do, not what you want the tabs to do.

It is a good idea to take your boat out onto open water shortly after you get it and experiment with the trim tabs. After you get your boat onto plane, set the tabs in various positions and note how your boat reacts. This will give you a feel for how the trim tabs work.

It is possible to extend the cylinder life expectancy on your trim tabs. To do this, keep the cylinders retracted while at dockside. Press both trim tab controls down until tabs reach their full up position.

### B. Tilt/Trim Control Switches

**NOTE:** Trim refers to the angle of the lower unit in relation to the bottom of the boat. With respect to trimming, the words in, down, under, and forward, have the same meaning as do up, out, and aft.

1. The standard trim control switch is located on the control lever handle.
2. The switch controls the position of the stern drive. Proper trim is very important in boating.
3. In the case of low or heavy bow attitude, the boat tends to “plow” (Figure T3. The lower unit is trimmed too far under or forward. Trim the unit UP (out) to correct this situation.
4. If the bow is too high, the boat tends to “porpoise” (Figure T5). The drive unit is trimmed up or out too far. Trim DN (in) to correct.
5. A good practice is to get underway (especially when fully loaded or pulling a skier) with the unit trimmed all the way DN (under). After the boat is on plane, adjust the trim out slightly to obtain the proper bow attitude and engine speed.
6. Trim also affects propeller selection and fuel efficiency. All models should be “propped” to be in the upper half of the maximum rpm range with the boat lightly loaded and the drive trimmed up to maximum. This configuration allows the engine to oper-

ate within the recommended rpm range with a heavy load.

The power unit should never be trimmed up to a point where the propeller cavitates (or slips). A rapid increase in engine rpm’s is evidence of cavitation. If this occurs accidentally while running at full throttle, immediately lower the drive trim and reduce the throttle until the slipping stops. If necessary, have your dealer reset the trim limit switch (if provided) to avoid overtrimming in the future.

If the prop slips at lower planing speeds, the drive may be trimmed too high. Immediately lower the drive unit until the prop grabs again to restore efficiency.

7. Trimming out, in addition to raising the bow, also lifts the boat higher, gaining speed because less hull is in the water.
8. The trailering position of some stern drives is controlled by a separate switch on the dash switch panel or throttle/shift control. **Do not activate this switch while engine is running. Doing so can severely damage the lower unit and engine.**

**NOTE:** Refer to the control instructions regarding the power trim controls installed on your boat.

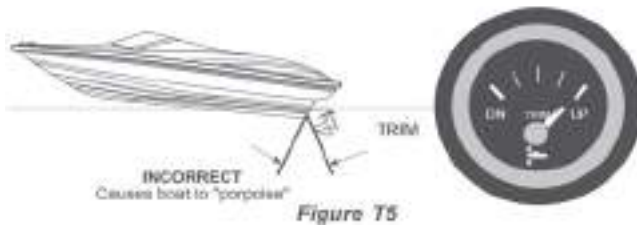
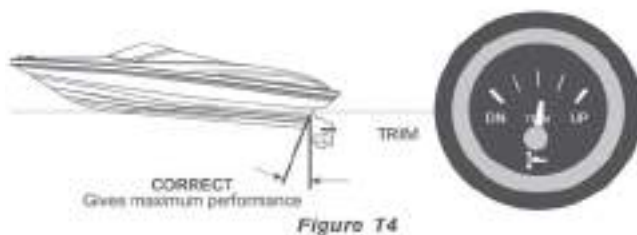
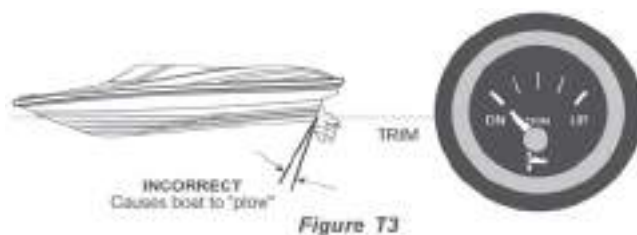

Figures T3-T5: Trimming the Boat with Outdrive

## T - 8 NAVIGATION LIGHTS

Although night activities are limited, cruising at night can be very pleasurable. It can also be dangerous if you don't pay close attention to water levels and obstacles. Be especially careful of shallow waters and watch for submerged debris, rocks and other obstacles in the water. Your navigation lights are intended only to prevent collision, not to improve your night vision. You may choose to use a spotlight instead.

**NOTE:** It is illegal to use your spotlight as a headlight. Use it only temporarily to check the position of your boat and the surrounding area.

Your boat has one white (stern), one red (port) and one green (starboard) light. The stern light may be a removable pole light. To use the light, line up the two-prong plug in the pole with the receptacle in the base. Plug the light in, and lock it into place with lever/slide lock. When not in use, stow the light inside your boat for safekeeping. This light can be turned on or off at the helm.

Check lights for proper operation before heading out at night. You should also learn to identify the running light combinations for other vessels. We recommend that you participate in a boating safety course to further learn about navigation lights and safe boating practices.

The anchor lights and navigation lights are controlled by a switch at the helm. The anchor light switch allows you to turn on just the stern (white) light when anchored or moored. While underway, use the navigation light switch to turn on the stern (white), port (red) and starboard (green) lights. Lights are off when switches are in the OFF position.

## T - 9 HAZARDOUS CONDITIONS

### A. Storms

Storms sometimes appear without advance notice. Although weather information from meteorological observation and reporting stations is available, weather bureaus are known to have failures in their predictions or information gathering equipment. There is no substitute for a strong understanding of what action to take when the weather takes a turn for the worse. Many marinas fly weather signals. You should learn to recognize these signals and monitor your local weather forecasts before leaving port.

The present and forecasted weather conditions are of primary consideration, but a threat of possible storms should always be a concern. Observance of the following information will help in your safety afloat if storms do occur:

- Keep a watch on the horizon for approaching storm indicators.
- Turn radio ON. Dial in local weather station and monitor forecast. If your boat has a VHF radio, check the weather channels.
- The best possible situation is to return to a safe port if time allows.
- Close and secure all portals and hatches. Stow all loose gear below deck and tie down any gear required to remain on deck.
- Reduce speed as the seas build. Make sure all passengers are wearing their PFDs.
- If you lose power, keep the boat headed into the waves by rigging a sea anchor off the bow. If there is no sea anchor on board, use a canvas bucket or any object that will offer resistance.
- Radar reflectors (if installed on your boat) should be 18 inches diagonally and placed 12 feet above the waterline.

### B. Fog

Fog is a result of either warm surface or cold surface conditions. You can judge the likelihood of fog formation by periodically measuring the air temperature and dew point temperature. If the spread (difference) between these two temperatures is small, you likely will incur a fog situation. Remember the following guidelines:

- Turn on running lights.
- As fog sets in, take bearings and mark your position on the chart while continuing to log your course and speed.
- Make sure all persons aboard are wearing their PFDs.
- If your boat has depth finding equipment, take sounding and match them with soundings on your charts.



- Station a person forward on the boat as a lookout.
- Reduce your speed. From time to time, stop engine and listen for fog signals.
- Sound the proper horn or fog bell at proper intervals to warn other boaters.
- If there is any doubt in continuing boat movement, anchor. Listen for other fog signals while continuing to sound the proper fog horn or bell for a boat at anchor.

### C. Running Aground



**WARNING**

To prevent boat damage, DO NOT use deck hardware or water ski pylon for towing. Use a commercial towing service.

Operating in shallow water can present a number of hazards. Sand bars in narrow inlets are constantly shifting, making it difficult to mark them with buoys. Sometimes sand bars are indicated by waves as they form into breakers when passing over sand bars. In coastal areas, tides can change water levels by as much as 30 feet. Check with local marinas or Coast Guard stations for tide tables and current charts.

If your boat runs aground, first check persons aboard for injury. Then check for damage to the boat. If the drive unit strikes an underwater hazard, check for boat and drive unit damage. If the engine vibrates excessively after striking an underwater obstruction, it may indicate a damaged propeller. If vibration is noticeable, return to port slowly to prevent further drive and engine damage from an out-of-balance condition. Watch the temperature gauge to make sure you do not overheat the engine.

If the boat is not taking on any water, it may be possible to rock the boat by shifting the weight of the passengers and gear and by raising the drive unit while reversing the engine.

If you ground your boat on a sand bar, shut down the engine and seek help from another boater or radio for help. See your dealer as soon as possible, as sand ingested in the engine cooling system can cause major engine damage.

### D. Warning Markers

It is a good idea to find out about hazardous areas and how they are marked by asking your local authorities.

- Boaters must also recognize the flag designs which indicate that scuba divers are present and keep well clear of the area.
- Watch for swimmers. Swimming areas may not be marked. Steer clear from the area and always remain alert.
- Distress flags indicate a fellow boater is in need of assistance.
- Navigation markers serve as a means of identifying navigable routes and indicate water hazards. Boaters should become familiar with navigation markers and stay within marked boundaries and clear of hazards.

## T - 10 REACTING TO EMERGENCIES

Be prepared to deal with emergencies before they happen. Try to formulate a plan for each type of emergency in advance so that decisions can be made quickly and without hesitation. Precious moments lost can mean the difference between losing and saving a life.

### A. Flooding

If your boat starts taking on water, activate the bilge pump immediately. Make sure all passengers are wearing their PFDs. Open the engine compartment, look for the cause of the flooding. Check all hoses, through hull fittings, seacocks and strainers. If flooding occurs as a result of collision or grounding damage, call for assistance and head for shore if possible.

### B. Capsizing and Man Overboard

By far, the largest number of boating fatalities involve capsizing and falling overboard accidents. By being prepared ahead of time with an appropriate plan of action, you can greatly lower your chances and your passengers' chances of becoming seriously injured.

### C. Capsizing

Wear PFDs or have them readily available at all times. If your boat capsizes, and others were on board, locate them and guide them to the safety of the hull. Even if the boat floats in an upside-down position, stay with it. The boat hull is much easier for rescuers to spot than a human head sticking out of the water. DO NOT attempt to swim ashore, it may be further than it looks.

### D. Man Overboard

Think through and follow these procedures if someone in your boat falls overboard.

- Remember, every second counts, you must act fast.
- Move throttles to idle position immediately and yell “MAN OVERBOARD.”
- Throw some floating object overboard immediately. Keep your required Type IV PFD accessible at all times for such an emergency.
- Keep the person in the water in sight at all times. Have a passenger do nothing but watch the person. Do not go into the water to help the victim. One person in the water is enough trouble.
- Circle around quickly, approaching into the wind and waves. When the person is alongside, put the engine in neutral and throw them a Type IV PFD with a line attached or extend a paddle or boat hook within his/her reach.

### E. Collision

If a serious collision occurs, you should first check the condition of all passengers aboard, then inspect your boat to determine the extent of damage.

1. Make sure all persons aboard are wearing their PFDs.
2. If you need help and your boat has a ship-to-shore radio, first contact the U. S. Coast Guard (VHF Channel 16) or other rescue authorities immediately.
3. Prepare to assist the other vessel unless your passengers and/or boat are in danger.
4. If the bow of the other boat penetrated your boat's hull, prepare to block the opening once the boats are separated.

5. Shore up the hole with a spare PFD or bunk cushion from your boat.

6. While blocking the hole, trim the boat so that the hole is out of the water.

### F. Fire

Most fires are caused by electrical problems or careless fueling practices. A fire on board your boat is a serious emergency. You must work quickly to implement safety procedures. If a fire occurs, immediately stop the engine.

1. Make sure all persons aboard are wearing their PFDs.
2. If the fire is small, attempt to put it out with your fire extinguisher. If the fire is in the engine compartment, turn off the bilge blower. Do not open the engine compartment. This feeds oxygen to the fire and may cause it to flare up.
3. If the fire gets out of control, execute a distress signal and call for help if equipped with a ship-to-shore radio.
4. All persons aboard should jump overboard and swim a safe distance away from the flames.

**IMPORTANT:** All persons aboard should know the location and proper operation of the fire extinguishers.

### Guidelines

- Use only approved marine cooking and heating systems.
- Open flames demand constant attention.
- Keep flammable materials in approved containers in a overboard vented locker sealed from the interior of the boat.
- Ensure ventilation systems are unobstructed.
- Remove mooring covers before starting engine.
- Check the bilge for fuel leaks.
- Extinguish smoking materials carefully.
- Use special care with flame or high temperatures around urethane foam.

- Check cleaning products for flammability.
- Ventilate when cleaning or painting.
- Disconnect electrical system from its power source before performing maintenance.
- Replace breaker or fuse with same amperage device.
- Electrical appliances must be within rated amperage of boat circuits. Observe the boat carefully while the electrical system is being energized.
- Allow only a qualified marine electrician to service the boats electrical system.

### G. Medical Emergency

Accidents while boating can and may happen. Be prepared to handle these emergencies when they happen. Keeping a first aid kit and dry blankets on board can assist during these situations. It is also a good idea to contact your local Red Cross for information and training on first aid and CPR.

### H. Propulsion Failure

Before you call for help regarding an engine or drive unit failure, it is a good idea to eliminate the possibility of simple problems. Turn off the engine and check to see that (1) there is fuel in the tank; (2) the engine cooling intakes on the outdrive are not clogged; (3) props are clean and free of weeds, netting, etc. ; (4) no hoses are leaking; (5) there is oil in the engine.

Once you have checked out the possibilities listed above and find they are not the problem, call for help giving your position and a detailed description of your boat.

### I. Control Failure

In the unlikely event of a shift/throttle failure, shut down the engine immediately. Carefully check the control connections in the engine compartment to see if they are secure. If not, try to locate the attaching hardware and reassemble. If that is not possible, try to use whatever is available such as paper clips, hair clips, tape, etc. , to secure the connections. If a temporary repair is made, return to port at the slowest steerable speed and be prepared to take emergency action should the temporary repair fail also. Have your dealer make repairs before using the boat again.

### J. Steering Failure

If a problem with the steering occurs, shut down the engine immediately. Check the connections to the drive unit in the engine compartment. Some boats have a push/pull cable while others will have hydraulic hose connections. With cable connections, check the attaching hardware and tighten it if necessary. If you have hydraulic hose connections, check to see if they are leaking. If so, tighten the connections and check the hydraulic fluid reservoir level. Most stern drives are power assisted and have their own hydraulic reservoir and engine mounted drive pump; check the level of reservoir and drive pump belt. If the steering is not operating properly, do not operate the boat and call for assistance.

### K. Additional Underway Information

- Always be aware of local laws on noise limits. Noise means engine noise, radio noise or even yelling by people on your boat. Good seamanship demands that you operate your boat quietly so as not to infringe on the rights of others. Don't use thru-transom exhaust unless you are well off shore.
- You are responsible for any damage or injury caused by your boat's wake. Observe no wake speed zone warnings. Operate your boat with regard for the safety of other boats and people in your boating area.
- Keep your engine well tuned to decrease exhaust hydrocarbon emissions that pollute the air and water.

## T - 11 RETURNING TO SHORE

### A. Docking

Always approach the dock slowly. Think before acting. If you are wondering whether your boat will fit in a space against a dock, remember that pilings are often (but not always) spaced 10 feet apart.

Remember that it is easier to control a boat in reverse because a boat steers from the stern. When backing into a slip, back so that bow swings into the wind if possible. You will have more control.

If possible, come in against the wind or current, whichever is stronger. Approach the dock at a 30-45° angle. As the boat nears the dock, slowly swing parallel to it. Tie the bow line first; then the stern.

If wind or current is moving toward the dock, move parallel to the dock further out. Let the wind or current push you in. Tie the stern first, then the bow.

Use extreme caution if wind or current is from your stern. Back in towards the dock slowly at a slight angle with engine in slow reverse. Gently swing parallel. Tie stern first, then the bow.

If the weather looks bad, use spring-lines from the bow and stern to dock amidships of the boat. Tie up on the downwind side of the dock. If the wind is changeable, place fenders over the side between the boat and the dock.

**B. Mooring**

After you have positioned your boat next to the dock, you must secure it with mooring lines to keep it in position. Mooring lines must be long enough to secure your boat in any docking situation. For example, the length of the lines for a 16-foot runabout should be at least 15 feet. An eye splice at the end of each line works well with bow or stern cleats.

The mooring lines you will use most often are the bow line, the stern line, and spring lines as shown on Figure T6. Each line has a specific purpose. The bow line and the stern line secure your boat's bow and stern. The two spring lines keep your boat from moving forward or backward when you are moored alongside a dock.

If you are mooring your boat for a short time, bow and stern lines may be the only lines you will need. If you are mooring your boat for a longer time or the currents are swift, you should use spring lines. The stern spring line leads from the boat's stern cleat forward to the piling or cleat on the dock. The bow spring line leads from the bow cleat aft to the dock.

If you are mooring your boat in a slip, bow and spring lines, port and starboard, will keep your boat in position.

**NOTE:** If tides are a consideration, be sure to leave slack in the lines to make up for the rise and fall of the water while your boat is docked.

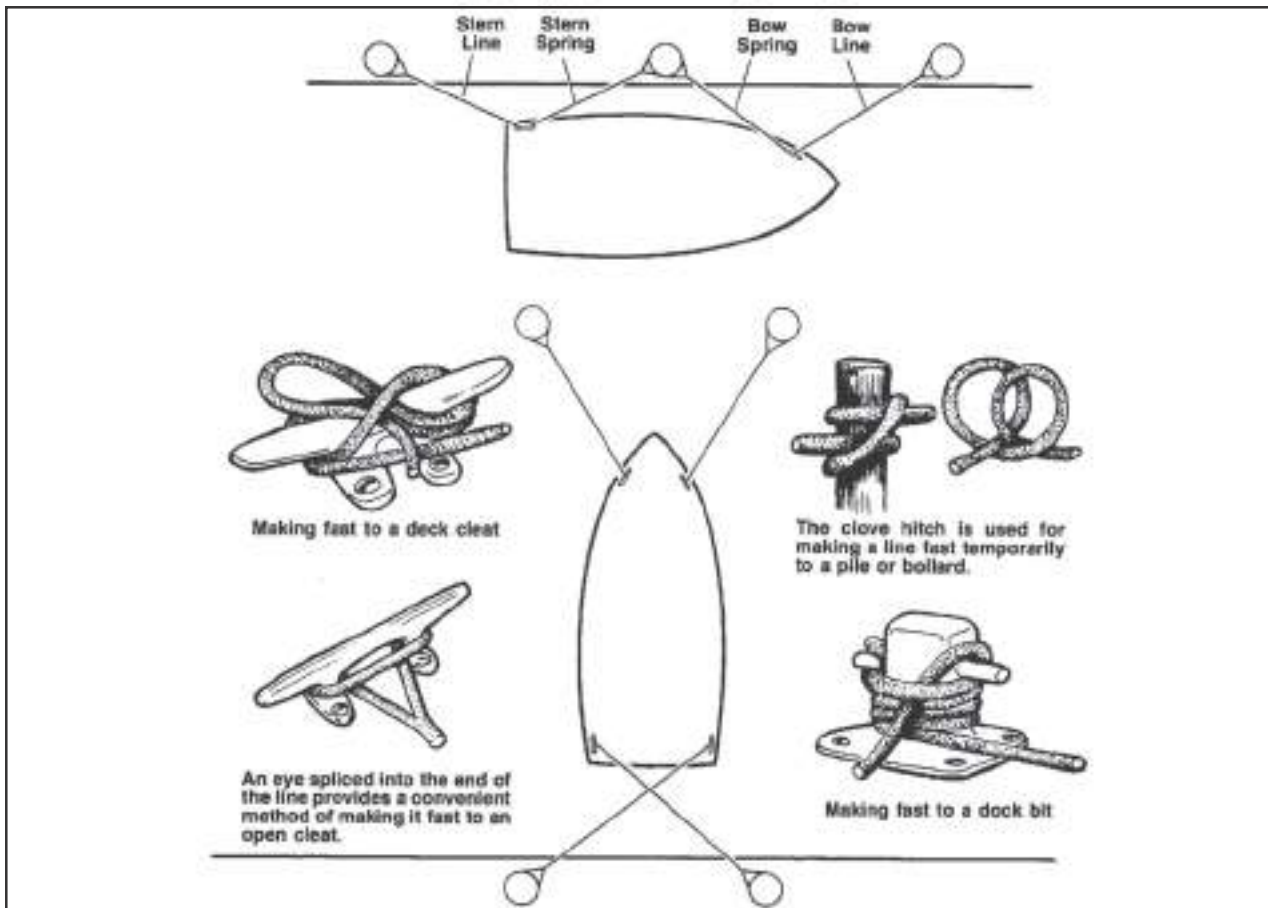

Figure T6: Mooring Lines

# GLOSSARY

**ABAFT** - Toward the rear of a boat.

**ABEAM** - At right angles to the keel of the boat.

**ABOARD** - On the boat.

**ABREAST** - Side by side.

**ADRIFT** - Loose, not on moorings or towline.

**AFT** - Moving toward the stern, you are going aft.

**AGROUND** - Stuck fast to the bottom.

**AHEAD** - In a forward direction.

**ALEE** - Away from the direction of the wind; opposite of windward.

**ALOFT** - Above the deck.

**AMIDSHIPS** - 1. An object or area midway between the bow and stern. 2. An object or area midway between the port side and the starboard side of a vessel.

**AMPERE** - The standard unit used to measure the draw of an electrical current.

**ANCHOR RODE OR ROPE** - The line (chain) connecting a vessel to its anchor.

**ANCHOR BALL** - A black, circular, day signal hoisted to show that a vessel is anchored. Replaced at dusk by the anchor light.

**ASTERN** - Anywhere behind the boat, a reverse direction, opposite of ahead.

**ATHWARTSHIPS** - A line, or anything else, running perpendicular to the fore-and-aft center line of a boat.

**BATTEN** - A strip of wood or metal used to secure tarpaulin(s) in place over a hatch. To batten down means to secure for rough weather.

**BEAM** - 1. The widest distance across a boat from the outside skin on one side to the outside skin on the other. 2. A transverse structural member that stiffens and supports a portion of the deck.

**BEAM WIND** - A wind blowing against the side of the vessel, perpendicular to the long axis of the vessel.

**BILGE** - The lowest interior area of a hull, used to collect water that has entered.

**BILGE PUMP** - A pump intended for removal of spray, rainwater, and the normal accumulation of water due to seepage and spillage; not intended for damage control.

**BINNACLE** - The stand or support for a magnetic compass occasionally used to mean helm.

**BITT** - A heavy and firmly mounted piece of wood or metal used for securing lines.

**BLOCK** - A wooden or metal case enclosing one or more pulleys and having a hook, eye, or strap by which it may be attached.

**BOLLARD** - A single post (wood, metal, or concrete) on a dock, pier, or wharf used to secure a vessel's lines.

**BONDING** - The electrical connection of exposed metallic, non-current carrying components to a common point on the main engine block.

**BOW** - The front end of the boat.

**BOW LINE** - A docking line leading from the bow.

**BREAKER** - A single breaking, plunging or spilling wave.

**BREAKER LINE** - The outer limit of the surf. However, all breakers may not be in a line. They can occur outside the breaker line.

**BRIDGE** - The main vessel control station.

**BROACH** - The turning of a boat parallel to the waves, subjecting it to possible capsizing.

**BULKHEADS** - The interior walls of a boat.

**BULWARK** - The side of a vessel when carried above the level of the deck.

**BUOY** - An anchored float used for marking a position on the water, a hazard, or a shoal.



**CAPSIZE** - To turn over.

**CAPSTAN** - A machine that moves a cylindrical device on a shaft for the purpose of hauling up an anchor.

**CAST OFF** - To let go.

**CATAMARAN** - A twin-hulled boat, with the hulls being side-by-side.

**CHINE** - The intersection of a boat's bottom and side. If this intersection is rounded, it is a "soft" chine. If the intersection is squared off, it is a "hard" chine.

**CHOCK** - 1. A fitting or hole in a railing or deck through which a mooring or anchor line is routed. 2. A wedge used to secure an item in place.

**CIRCUIT BREAKER** - A device used to interrupt an electrical circuit when current flow exceeds a predetermined level.

**CLEAT** - A double-ended deck fitting to which lines are secured; usually anvil-shaped.

**COAMINGS** - Raised lips around cockpits or hatches used to keep water from entering

**COCKPIT** - An exposed deck area (usually aft) that is substantially lower than the adjacent deck.

**COMBER** - A wave on the point of breaking. A comber has a thin line of white water on its crest, known as "feathering."

**COMPANIONWAY** - The steps or ladder leading downward from a deck.

**COMPARTMENTS** - Rooms divided by bulkheads.

**COUNTER** - The overhang at the stern of a boat.

**CRADLE** - A framework, generally made of wood, used to support a boat when it is out of the water.

**CREST** - The top of a wave, breaker or swell.

**CUDDY** - A small sheltered cabin in a boat.

**CURRENT** -1. The movement of water, 2. The flow of electrical charge.

**DEAD AHEAD** - Directly in front of the boat.

**DEAD RECKONING** - A plot of courses steered and distances traveled through the water.

**DECK** - A permanent covering over a compartment, hull or any part thereof.

**DINGHY** - A small, open boat used for ship to shore transportation.

**DISPLACEMENT** - The weight of water displaced by the hull of a vessel.

**DISPLACEMENT HULL** - A hull that "displaces" a volume of water equal to the weight of the boat. A hull designed to run in the water rather than on top of the water. When a displacement hull moves through the water, it pushes that water out of the way. Water will then flow around the hull and fill the "hole" the boat leaves astern.

**DOCUMENTED VESSEL** - Documented yachts have been specially registered with the U.S. Coast Guard. All documented yachts must have their name and home (hailing) port marked on some conspicuous place on the hull. Numbering is not required. Advantages include legal authority to fly the yacht ensign, privilege of recording bills of sale, and other instruments of title with federal officials, and preferred status for mortgages. Documentation does not exempt the unit from any State or Federal taxes. All safety and equipment regulations still apply.

**DOLPHIN** - A group of piles driven close together and bound with wire cables into a single structure.

**DRAFT** - 1. The depth of a boat from the actual water line to the bottom of the lowest part of the boat (e.g., the propeller tip or rudder). 2. The depth of water necessary to float a boat.

**DROGUE** - Any device streamed astern to check a vessel's speed, or to keep its stern up to the waves in a following sea.

**DYE MARKER** - A brightly colored chemical that spreads when released into water; normally used to attract attention.

**EBB TIDE** - A receding tide.

**EVEN KEEL** - To be floating evenly without listing to either side.

**EXHAUST SYSTEM** - The means by which the hot engine (or generator) exhaust gases are moved from the engine to an outboard port and then released into atmosphere.

**EYE SPLICE** - A permanent loop spliced in the end of a line.

**FAST** - Said of an object that is secured to another.

**FATHOM** - Six feet.

**FENDER** - A device (usually constructed of rubber or plastic) positioned so as to absorb the impact between vessels or dock.

**FETCH** - The unobstructed distance that the wind can blow over the water to create waves.

**FLARE** - 1. Outboard curve of the hull as it comes up the side from the waterline; the reverse of tumble home. 2. A pyrotechnic device used for emergency signaling.

**FLAT** - A small deck that is built below decks, specifically to support a piece of equipment.

**FLEMISH** - To coil down a line or rope on deck in a flat, circular, concentric arrangement.

**FLOTSAM** - Floating wreckage, trash or debris.

**FLUKE** - The palm of an anchor.

**FOAM CREST** - The top of the foaming water that speeds toward the beach after a wave has broken, commonly referred to as "white water."

**FOLLOWING SEA** - A sea (waves) moving in the same direction as a vessel.

**FORE-AND-AFT** - A line, or anything else, that runs parallel to the longitudinal center line of a boat.

**FOREFOOT** - The portion of a vessel's keel that curves upward to meet the stem.

**FOREPEAK** - A compartment in the bow of a boat.

**FORWARD** - Toward the bow.

**FREEBOARD** - The minimum vertical distance from the surface of the water to the gunwale.

**FREQUENCY** - The number of crests passing a fixed point at a given time.

**FRONTS** - Where opposing warm and cold air masses meet, generally producing a band of wet, stormy weather wherever they meet.

**GALLEY** - The kitchen area of a boat.

**GALVANIC CORROSION** - A potential electrical difference exists between dissimilar metals immersed in a conductive solution (e.g., salt water). If these metals touch or are otherwise electrically connected, this potential difference produces an electron flow between them. The attack on the less corrosion resistant metal is usually increased and the attack on the more resistant metal is decreased, as compared to when these metals are not touching.

**GANGWAY** - The area of a ship's side where people board and disembark.

**GASKET** - A strip of sealing material, usually rubber, set along the edge of a water or gas tight door, port, cover or hatch.

**GELCOAT** - The thin outer layer of pigmented plastic covering a fiberglass vessel.

**GLAND** - The movable part of a stuffing box, which when tightened, compresses the packing.

**GROUND** - Electrical term meaning the electrical potential of the earth's surface, which is zero.

**GROUND SPEED** - A vessel's speed made good over the earth's surface along a course or track.

**GROUND TACKLE** - The anchor, anchor rodes, and other fittings that are used to secure a vessel at anchor or dockside.

**GUNWALE** - 1. The line where the upper deck and the hull meet. 2. The upper edge of a boat's side.

**HALYARD** - A line used to hoist a flag or pennant.

**HATCHES** - Cover on hatchways.

**HATCHWAYS** - Access ways through decks.

**HARDTOP** - A permanent cover over the cabin or cockpit.

**HAWSER** - A heavy rope or cable used for mooring or towing.

**HEAD** - A toilet or lavatory area.

**HEADING** - The direction that a vessel is going with reference to true, magnetic, or compass north.

**HEADWAY** - The forward motion of a vessel through the water.

**HEAVE TO** - To bring a vessel up in a position where it will maintain little or no headway, usually with the bow into the wind.

**HEAVY WEATHER** - Stormy weather with high seas and strong winds.

**HEEL** - To tip to one side.

**HELM** - The wheel or tiller that manually controls the boat's steering system.

**HELMSMAN** - The individual steering the vessel.

**HIGHS** - A center of pressure surrounded by lower pressure on all sides. Caused by a mass of cooler, sinking, drier air. This raises the area ground level air pressure and provides clear skies.

**HULL** - The main body of a boat.

**INBOARD** - 1. From either the port or starboard side of a boat toward the fore-and-aft centerline of a boat. 2. The dock side of a moored boat.

**INLAND RULES** - Nautical "Rules-of-the-Road" that apply in U.S. lakes, rivers, and coastal waters.

**INTERNATIONAL RULES** - Nautical "Rules-of-the-Road" that are in effect by international agreement to the high seas.

**ISOBARS** - Lines of equal air pressure that connect all the local points on a weather map. These lines are usually closed and define high or low pressure air masses.

**ISOTHERMS** - Isotherms are lines that are similar to isobars except that isotherms connect all the points that are of equal temperature.

**JETSAM** - Refuse that sinks when discharged overboard.

**KEDGE(S)** - One or more anchors set out from a grounded vessel, usually astern, to 1) keep it from being driven further aground and 2) to aid in refloating.

**KEEL** - 1. The centerline of a boat hull bottom running fore and aft, 2. The backbone of a vessel.

**KNOT** - 1. A maritime unit of speed equal to one nautical mile per hour (6076 feet). 2. A term for hitches and bends.

**LANYARD** - A short line made fast to an object to secure it.

**LATITUDE** - The measure of angular distance in degrees, minutes, and seconds, north or south of the equator.

**LAZARETTE** - Storage compartment in the deck at the stern.

**LEADLINE** - A weighted line used to take depth measurements.

**LEE** - The direction opposite that of the wind.

**LEEWARD** - Away from the wind.

**LIST** - A vessel that inclines to port or starboard.

**LORAN** - Long Range Navigation. An electronic system whereby a navigator can determine position regardless of weather.

**LONGITUDINAL** - Running lengthwise.

**LOWS** - A region of low atmospheric pressure. Hurricanes are extremely concentrated low pressure systems.

**LUBBER LINE** - A mark or line on the compass parallel to the keel indicating forward.

**MAST** - A spar that is set upright to support lighting, rigging, or sails.

**MOORING** - An arrangement for securing a boat to a mooring buoy or pier.

**NAVIGATION LIGHTS** - A set of red and green or white lights which must be shown by all vessels between dusk and dawn.

**OVERHEAD** - A ceiling or roof of a vessel.

**OVERBOARD** - Over the side of the boat.

**OUTBOARD** - 1. From the fore-and-aft centerline of a boat toward both the port and starboard sides. 2. The seaward side of a moored boat. 3. An engine that is mounted externally onto the transom of a boat.

**PAINTER** - A line to the bow of a small boat used for making fast.

**PASSAGEWAY** - A corridor or hallway aboard ship.

**PENNANT** - The line by which a boat is made fast to a mooring buoy; also pendant.

**PERSONAL FLOATATION DEVICE (PFD)** - A life preserver.

**PIER** - A loading platform that extends at an angle from the shore.

**PILASTER** - A rectangular structural support column that is an extension of the port and starboard aft cabin sides and which supports the hardtop and flybridge.

**PILING** - Support, or protection for wharves, piers, etc.

**PITCH** - 1. The vertical (up and down) motion of a bow in a seaway, about the athwartships axis. 2. The axial advance of a propeller during one complete revolution.

**PITCHPOLING** - A boat being thrown end-over-end.

**PLANING HULL** - At slow speeds, a planing hull will displace water in the same manner as a displacement hull. As speed is increased, the hull provides a lifting effect up onto the surface of the water.

**POINT** - One of 32 points of the compass that is equal to 11-1/4 degrees.

**PORT** - 1. Looking forward, the left side of a boat, 2. A harbor, 3. An opening for light or ventilation or passage of material in the side of a boat.

**PORT BEAM** - The left-center of a boat.

**PORT BOW** - Facing the bow, the front left side.

**PORT QUARTER** - Looking forward, a vessel's left rear section.

**QUARTER** - The sides of a boat aft of amidships.

**QUARTERING SEA** - Sea coming on a boat's quarter.

**RED-RIGHT-RETURNING** - A term for helmsmen that buoys and day markers are on the right when returning from seaward.

**REEF** - A shallow underwater barrier.

**REEVE** - To pass a line through a block or other opening.

**RIDGES** - High pressure fingers extending out from a high.

**RODE** - The anchor line or chain.

**RUNNING LIGHTS** - Lights required to be shown on boats underway between sundown and sunup.

**RUDDER** - A vertical plate for steering a boat.

**SALON** - The main social cabin on a vessel, usually the largest area, occasionally referred to as the deckhouse.

**SCREW** - A propeller.

**SCUPPER** - A drain from the edge of a deck that discharges overboard.

**SEACOCK** - A positive action shut-off valve connected directly to the hull seawater intake and discharge piping.

**SERIES** - A group of waves which seem to travel together and at about the same speed.

**SHACKLE** - A "U" shaped connector with a pin or bolt across the open end.

**SHAFT** - The long, round member that connects the engine or transmission to the propeller.

**SHAFT LOG** - A fitting at the hull bottom where the shaft connecting an engine to its propeller penetrates the hull. A shaft log permits the shaft to rotate while simultaneously preventing water from entering the hull.

**SHEER** - The top of the hull's curvature at the deck line from the bow to the stern.

**SHEER STRAKE** - The upper edge of the hull, immediately below the deck.

**SHEET BEND** - A knot used to join tow ropes.

**SHOAL** - An area of shallow water.

**SILENCER** - A baffled chamber installed in an exhaust system to reduce the noise.

**SOLE** - Term for deck, cabin or cockpit floor.

**SPAR** - A general term for booms, masts, yards etc.

**SPRING LINE** - A pivot line used in docking, undocking, or to prevent the boat from moving forward or astern while made fast to a dock.

**STARBOARD** - Looking forward, the right side of a boat.

**STARBOARD BEAM** - The right-center of a boat.

**STARBOARD BOW** - When facing the bow, the front right side.

**STARBOARD QUARTER** - When looking forward, the right rear section of the boat.

**STEERAGEWAY** - The lowest speed at which a vessel can be controlled by the steering wheel.

**STEM** - The leading edge of a boat's hull.

**STERN** - The back of a boat.

**STRINGER** - A fore and aft continuous member used to provide a vessel longitudinal strength.

**STRUT** - A propeller shaft support that is below the hull.

**SUMP** - A pit or well into which water is drained.

**SUPERSTRUCTURE** - Deck houses and other structures extending above the deck.

**THWART** - A seat or brace running laterally across a boat.

**THWARTSHIPS** - At right angles to the centerline.

**TILLER** - A bar or handle for turning a boat's rudder, or motor.

**TOPSIDE** - To go up to the top deck.

**TRANSOM** - The stern cross-section of a square sterned boat.

**TRANSVERSE** - Across the vessel; athwartships.

**TRIM** - Fore and aft balance of a boat.

**TROUGH** - 1. The valley that exists between waves. 2. A trough is the opposite of a ridge in that it is an elongated low-pressure area extending out from a low. A trough normally indicates unsettled weather.

**TUMBLE HOME** - The opposite of flare. The shape of the hull as it moves outboard going down from the gunwale to the waterline or chine.

**UNDERWAY** - Movement. Usually referring to a vessel proceeding forward.

**V-BOTTOM** - A hull with the bottom section in the shape of a "V."

**V DRIVE** - A drive system that has the output of the engine facing forward and coupled to a transmission. The prop shaft is then coupled to the transmission.

**WAKE** - Moving waves, track or path that a boat leaves behind it when moving across the water.

**WATER LINE** - The line of the water on the hull when the vessel is afloat.

**WATCH** - A 4 hour duty period while at sea.

**WAVES** - Waves are periodic disturbances of the sea's surface, caused by wind, seaquakes, and the gravitational pull of the moon and the sun.

**WAVE GRADIENT** - A wave's slope or angle from trough to crest with respect to the horizon.

**WAVE HEIGHT** - From the bottom of a wave's trough to the top of the crest.

**WEATHER DECK** - A deck with no overhead protection.

**WET EXHAUST** - This term refers to an exhaust system where the cooling seawater is mixed with the exhaust gases just after the riser. This mixture is then ejected through the drive or ports located in the transom or hull sides.

**WHARF** - A man-made structure bounding the edge of a dock and built along the shoreline.

**WHIPPING** - The act of wrapping the end of a piece of rope with small line, tape or plastic to prevent it from fraying.

**WINDLASS** - A device used to raise and lower the anchor.



WINDWARD - Toward the direction from which the wind is coming.

YAW - 1. To swing off course, as when due to the impact of a following or quartering sea. 2. Any motion about a vertical axis.

# FLOAT PLAN

Copy this page and fill out before going boating. Leave the completed copy with a reliable person who can be depended upon to notify the Coast Guard, or other rescue organization, should you not return as scheduled. DO NOT file this plan with the Coast Guard.

Name \_\_\_\_\_ Telephone \_\_\_\_\_

Description of Boat \_\_\_\_\_ Type \_\_\_\_\_ Color \_\_\_\_\_ Trim \_\_\_\_\_

Registration Number \_\_\_\_\_

Length \_\_\_\_\_ Name \_\_\_\_\_ Make \_\_\_\_\_

Four Winns® Hull Identification Number \_\_\_\_\_

Other Information \_\_\_\_\_

Persons Aboard: Name	Age	Address	Telephone

Engine Type \_\_\_\_\_ HP \_\_\_\_\_

Number of Engines \_\_\_\_\_ Fuel Capacity \_\_\_\_\_

**Survival Equipment:**

PFDs \_\_\_\_\_ Flares \_\_\_\_\_ Mirror \_\_\_\_\_

Smoke Signals \_\_\_\_\_ Flashlight \_\_\_\_\_ Food \_\_\_\_\_

Paddles \_\_\_\_\_ Water \_\_\_\_\_ Anchor \_\_\_\_\_

Raft or Dinghy \_\_\_\_\_ EPIRB \_\_\_\_\_ Sea Anchor \_\_\_\_\_

**Navigation Equipment:**

Compass \_\_\_\_\_ Loran \_\_\_\_\_ GPS \_\_\_\_\_ Radar \_\_\_\_\_

Radio: Yes \_\_\_\_\_ No \_\_\_\_\_ Type \_\_\_\_\_ Frequency \_\_\_\_\_

Phone: Yes \_\_\_\_\_ No \_\_\_\_\_ Phone Number \_\_\_\_\_

Destination \_\_\_\_\_ Estimated Time of Arrival \_\_\_\_\_

Expected to Return By \_\_\_\_\_

AutoType \_\_\_\_\_ License No. \_\_\_\_\_ Where \_\_\_\_\_

If not returned by \_\_\_\_\_ call the Coast Guard, or \_\_\_\_\_

Local Marine Authority

Coast Guard Telephone Number: \_\_\_\_\_

Local Marine Authority Telephone Number: \_\_\_\_\_















# SERVICE INFORMATION

BOAT MODEL	
HULL IDENTIFICATION NUMBER	
ENGINE MODEL	
ENGINE SERIAL NUMBER(S)	
DRIVE MODEL	
DRIVE SERIAL NUMBER(S)	
PROPELLER DIAMETER	
PROPELLER PITCH	
PROPELLER PART NUMBER(S)	
OIL FILTER NUMBER	
BOAT COLOR	
COCKPIT UPHOLSTERY COLOR	
CABIN UPHOLSTERY COLOR	
FUEL CAPACITY	
FUEL: ESTIMATED AVG. GALLON/HR USAGE	
IGNITION KEY NUMBER(S)	
GLOVE BOX KEY NUMBER	
COMPANIONWAY KEY NUMBER	
TRAILER MODEL	
TRAILER COLOR	
TRAILER SERIAL NUMBER	
TRAILER TIRE SIZE & MANUFACTURER	
SELLING DEALER	
ADDRESS	
CITY & STATE	
PHONE NUMBER	
MISCELLANEOUS	

# FREEDOM™/HORIZON™ LOCATOR DRAWING

(Note: Representative Location Only - availability and locations may vary on certain models.)

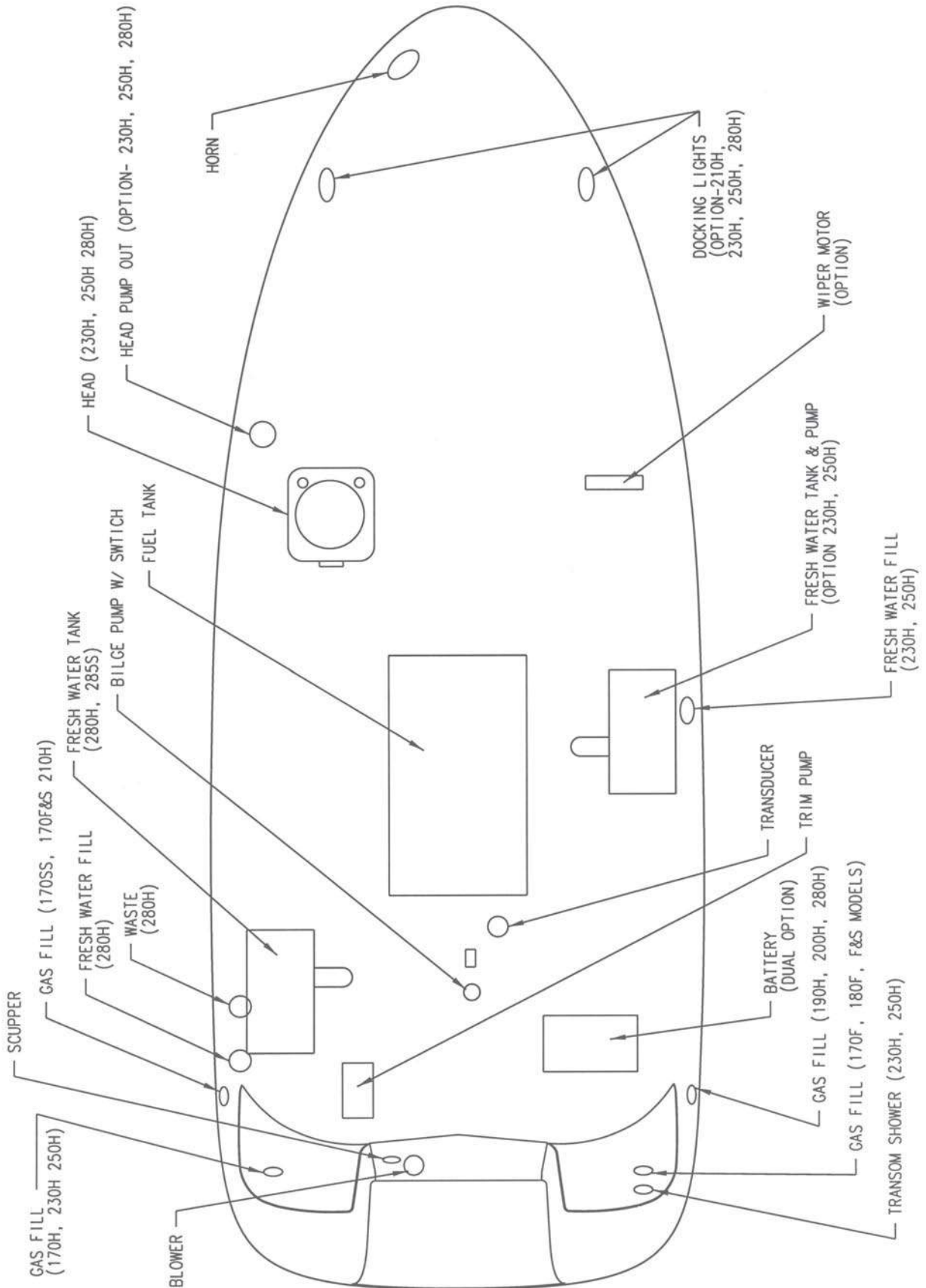



## Galvanic Isolator Installation

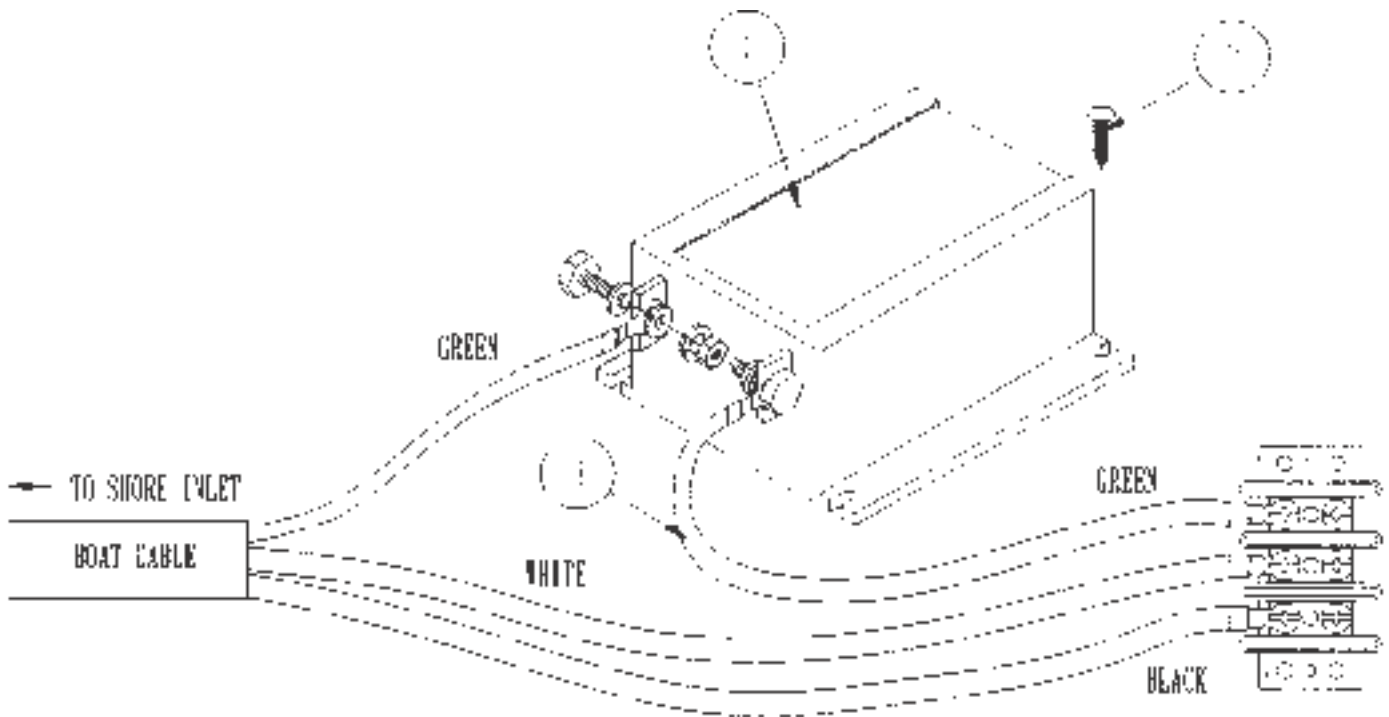

SINGLE SHORE POWER INSTALLATION

DESCRIPTION	PART #	QUANTITY
Galvanic Isolator, 30 Amp Guest #2433	028-1349	1 EA
Screw, #10 x 3/4" PTHSMS	080-0033	4 EA
Harness Assembly, Galvanic Isolator, 24"	027-1937	1 EA

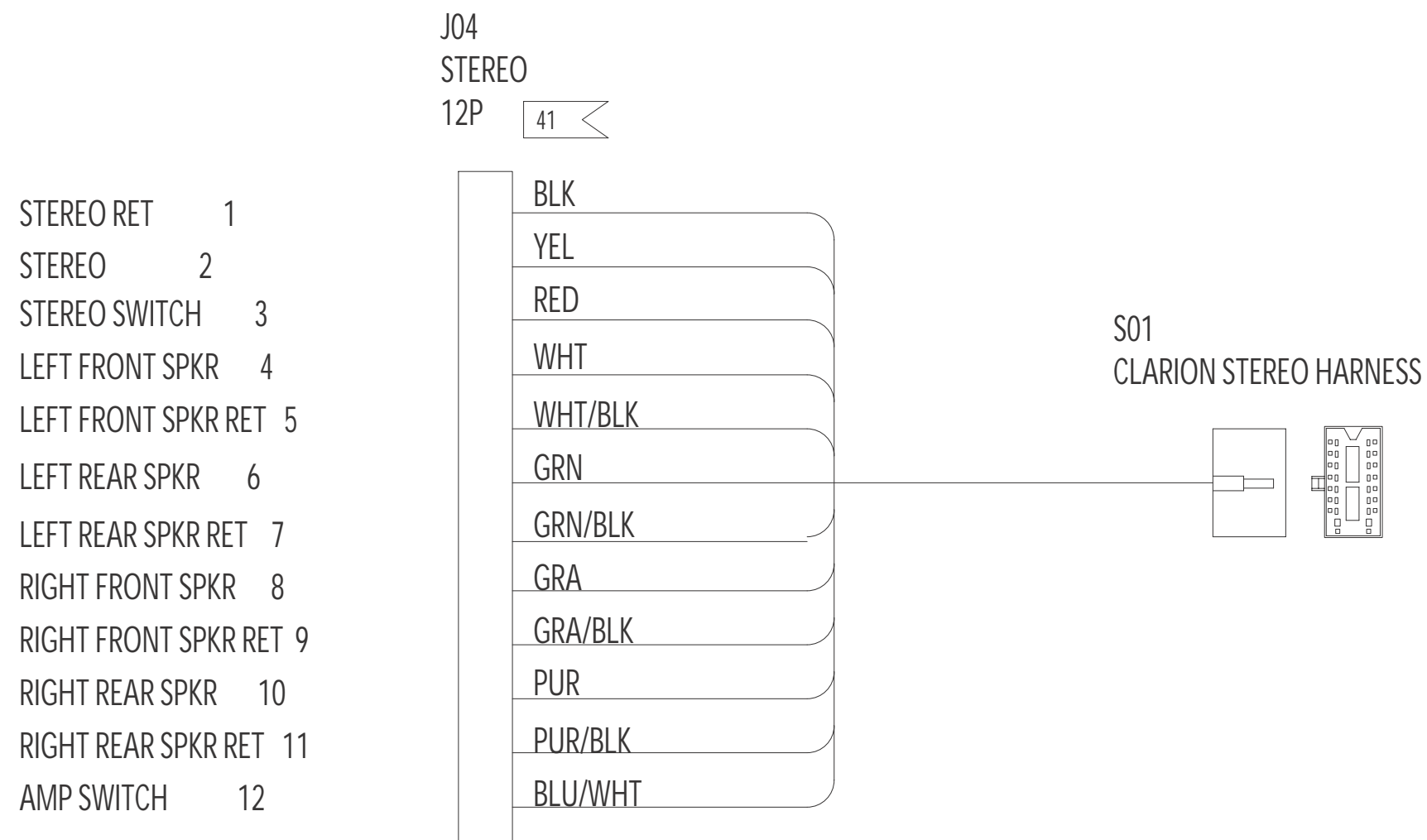

## FOUR WINNS PARTS LIST

ITEM	PART NUMBER	QUANTITY	DESCRIPTION	FUNCTION	MANUFACTURER
	028-0390	3	PIN,UMNL,18-14	41	AMP
	028-1036	8	PIN,UMNL,24-18	57	AMP
J04	028-0445	1	RECEPT,UMNL,12 CKT	STEREO ADAPTOR	AMP
S01	027-2441	1	CLARION STEREO PLUG ASSY	CLARION STEREO	CLARION

**COMMON WIRING  
CLARION STEREO ADAPTER  
HARNESS ASSEMBLY**

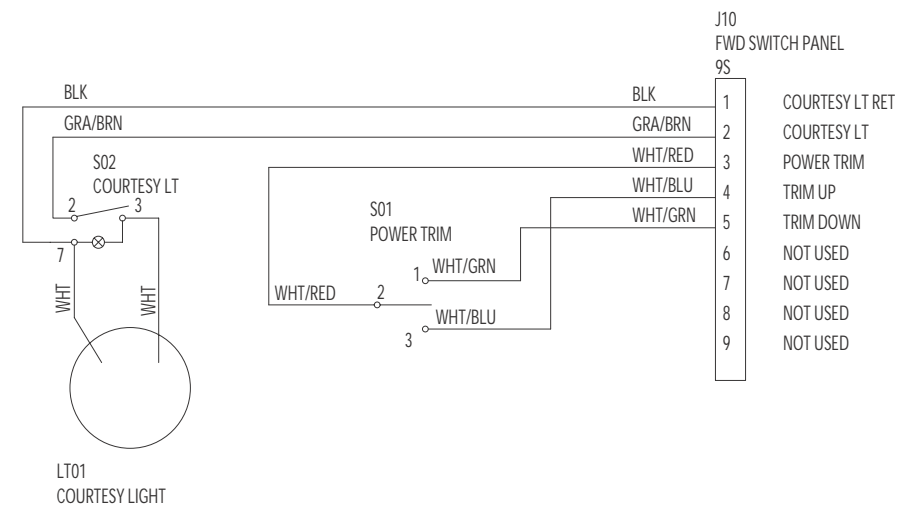
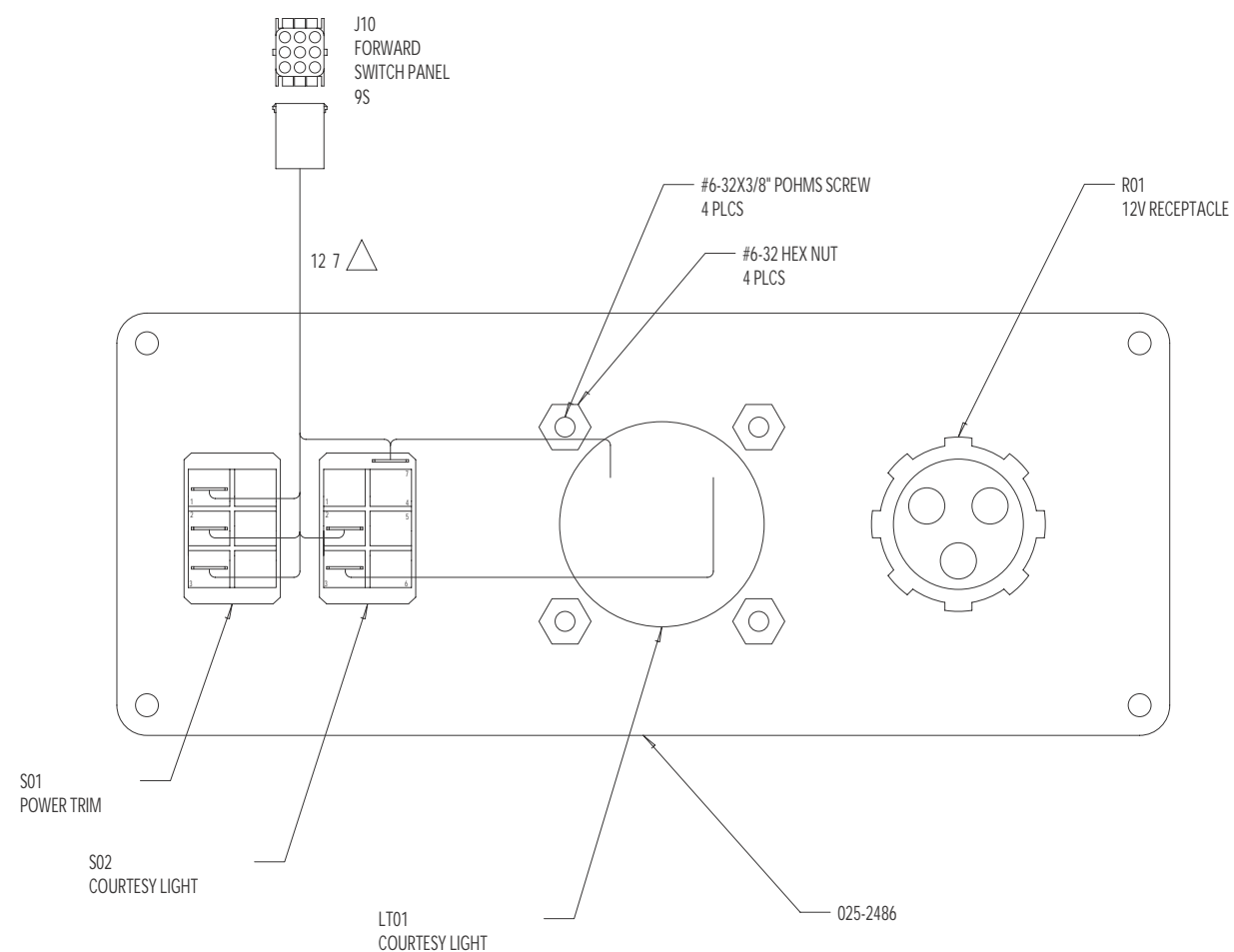

**FOUR WINNS PARTS LIST**

ITEM	PART NUMBER	QUANTITY	DESCRIPTION	FUNCTION	MANUFACTURER
	028-0177	6	RECEPT,FASTON, 250,18-14	02	AMP
	028-0454	5	SOCKET,UMNL,18-14	42	AMP
	080-0029	4	SCREW,#6-32X3/8" POHMS SS	COURTESY LT	
		4	NUT,#6-32 HEX SS	COURTESY LT	
	025-2486	1	PANEL,BLANK,FISH & SKI 2001		
J10	028-0443	1	RECEPT,UMNL,9 CKT	FWD SWITCH PANEL	AMP
R01	028-1394	1	RECEPT,12V TROLL MTR 12VBR.OEM	TROLLING MOTOR	MARINCO
S01	028-0469	1	SWITCH,SPDT,(ON)OFF(ON) CONT III	POWER TRIM	CARL SW
S02	028-0457	1	SWITCH,SPST,CONT III	COURTESY LIGHT	CARL SW
LT01	026-0138	1	LIGHT,SQUARE CTSY,7-02CMW	COURTESY LIGHT	BEACON

**FOUR WINNS WIRE LIST**

COLOR	GA	FIRST	PIN	TERM	NOTE	SECOND	PIN	TERM	NOTE	FUNCTION
BLK	16	J10	1	42		S02	7	02		COURTESY LT RET
GRA/BRN	16	J10	2	42		S02	2	02		COURTESY LT
WHT/RED	16	J10	3	42		S01	2	02		POWER TRIM
WHT/BLU	16	J10	4	42		S01	3	02		TRIM UP
WHT/GRN	16	J10	5	42		S01	1	02		TRIM DOWN
WHT	16	LT01	1	51		S02	3	02		LIGHT POWER
WHT	16	LT01	2	51		S02	7	02		LIGHT RET

**FREEDOM/HORIZON  
FISH & SKI  
PANEL ASSEMBLY**

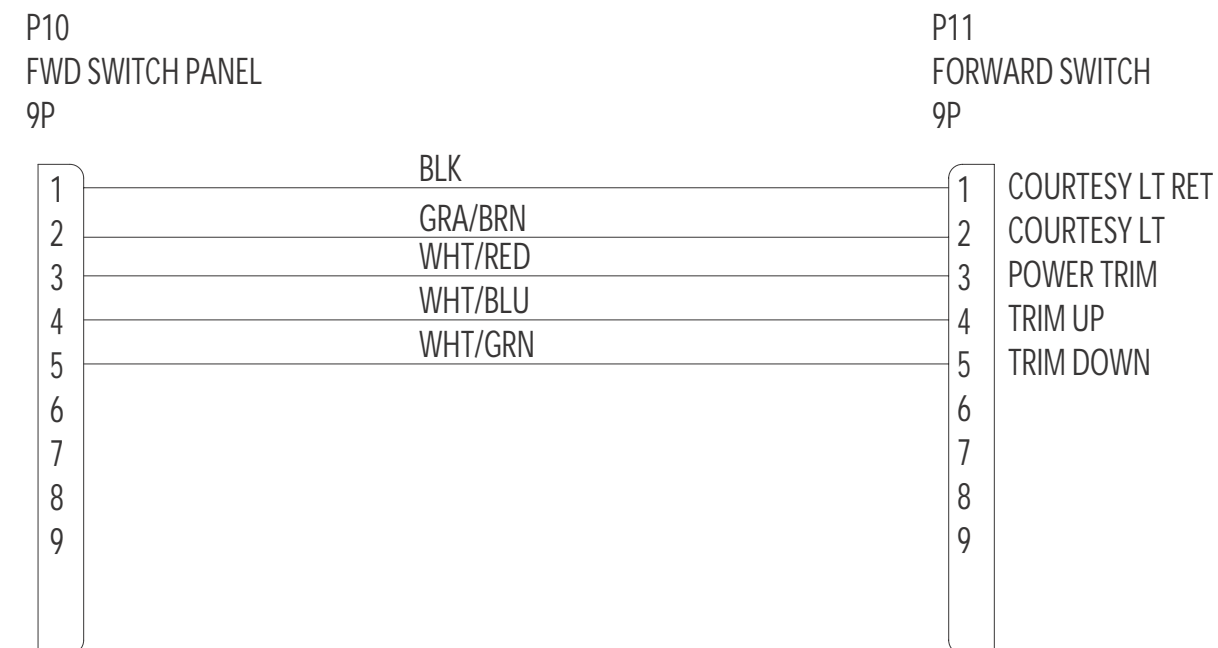

COURTESY LT RET  
 COURTESY LT  
 POWER TRIM  
 TRIM UP  
 TRIM DOWN

**FOUR WINNS PARTS LIST**

ITEM	PART NUMBER	QUANTITY	DESCRIPTION	FUNCTION	MANUFACTURER
	028-0390	10	PIN,UMNL,18-14	41	AMP
P10	028-0449	1	PLUG,UMNL,9 CKT	FWD SYSTEMS	AMP
P11	028-0449	1	PLUG,UMNL,9 CKT	FORWARD SWITCH	AMP

**FOUR WINNS WIRE LIST**

COLOR	GA	FIRST	PIN	TERM	NOTE	SECOND	PIN	TERM	NOTE	FUNCTION
BLK	16	P10	1	41		P11	1	41		COURTESY LT RET
GRA/BRN	16	P10	2	41		P11	2	41		COURTESY LT
WHT/RED	16	P10	3	41		P11	3	41		POWER TRIM
WHT/BLU	16	P10	4	41		P11	4	41		TRIM UP
WHT/GRN	16	P10	5	41		P11	5	41		TRIM DOWN

**FREEDOM/HORIZON  
 FISH & SKI  
 FORWARD SWITCH PANEL  
 HARNESS ASSEMBLY**

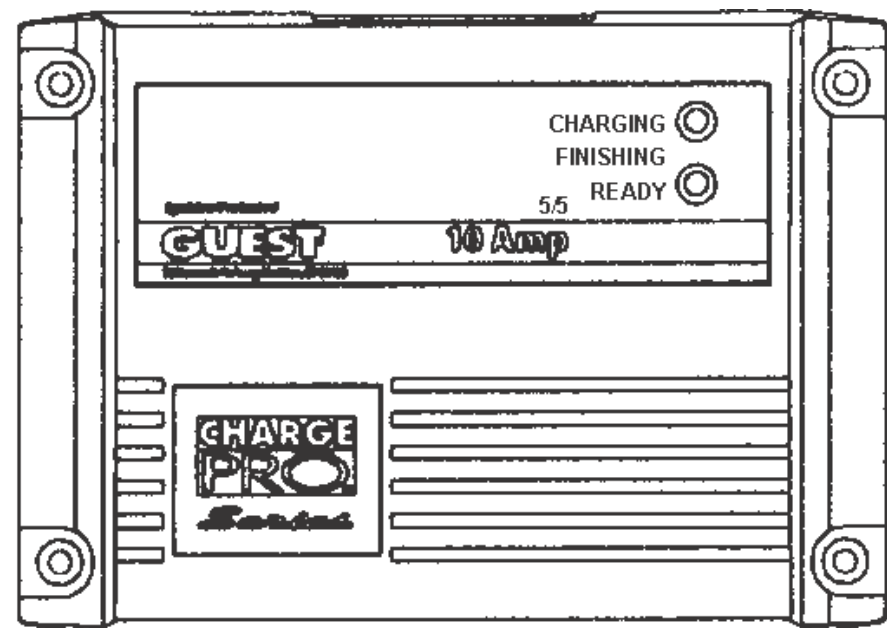

MANUFACTURER: GUEST  
 MANUFACTURER DESCRIPTION: 10A CHARGE PRO  
 MANUFACTURER PART NUMBER: 2611-B

**DC OUTPUT**

MAXIMUM: 10A AT 12V  
 FLOAT: 0.1A TO 0.3A AT 13.5 VOLTS  
 INPUT VOLTAGE: 90 TO 140V/50 OR 60 Hz  
 INPUT CURRENT: 3A MAXIMUM  
 GROUNDING: INDEPENDENT  
 # OF BANKS: 2

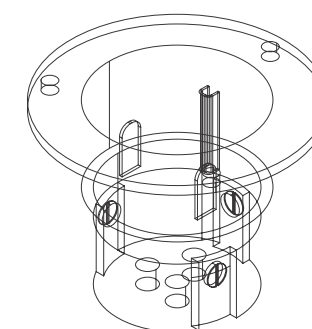
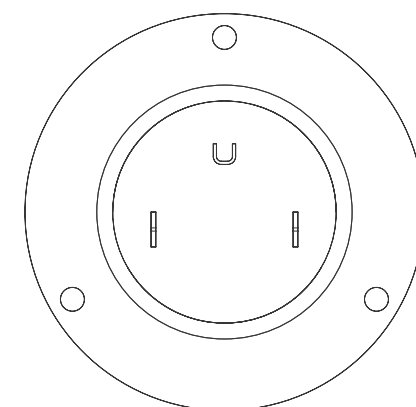

**ON-BOARD CHARGER INLET**

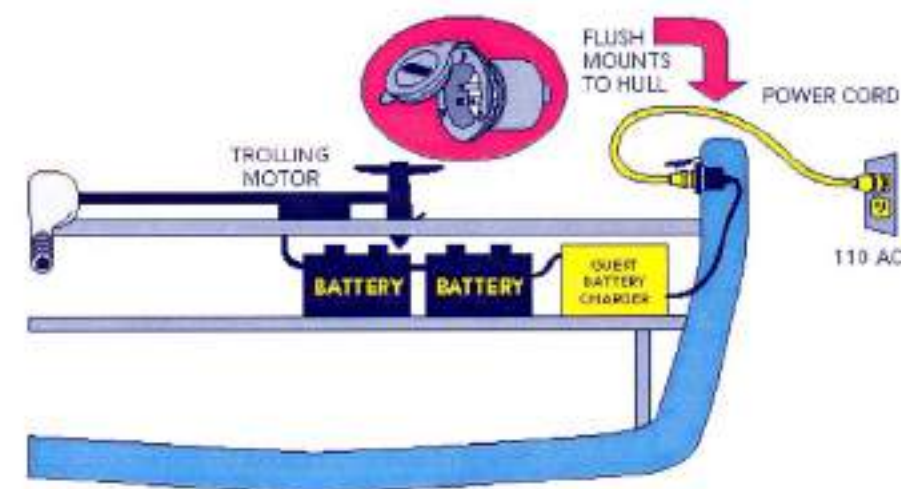
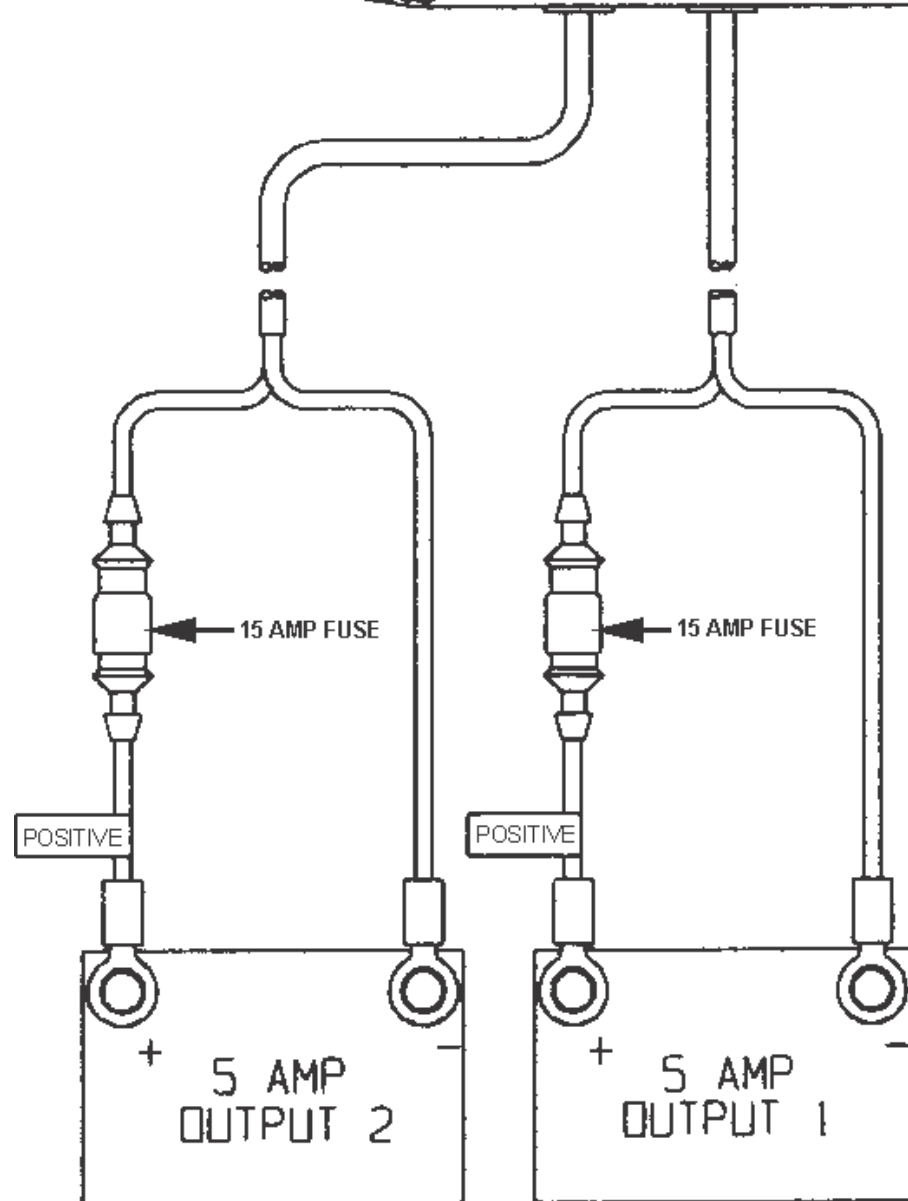

NOTE: REPRESENTATIVE VIEW ONLY

**FREEDOM/HORIZON  
 FISH & SKI  
 BATTERY CHARGER & CHARGER INLET**



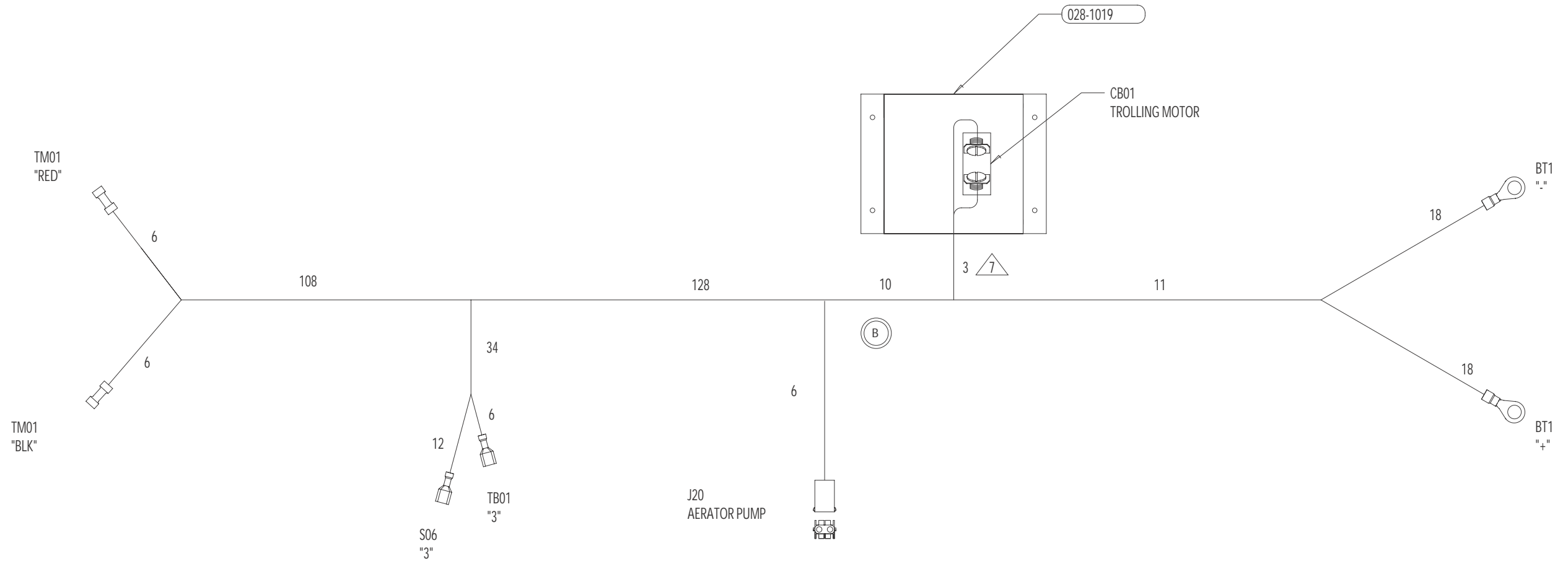

**FOUR WINNS PARTS LIST**

ITEM	PART NUMBER	QUANTITY	DESCRIPTION	FUNCTION	MANUFACTURER
	028-0315	2	TERM,RING,1/4,8 GA	24	AMP
	028-0177	2	RECEPTACLE,FASTON,250,16-14	02	AMP
	028-0454	2	SOCKET,UMNL,18-14	42	AMP
		2	CONNECTOR,BUTT,8 GA		AMP
	028-0316	4	TERM,RING,3/8,8 GA	25	AMP
J23	028-0441	1	RECEPT,UMNL,2 CKT	AERATOR	AMP
BT1		REF	BATTERY	TROLLING MOTOR BATTERY	
CB01	028-0577	1	BREAKER,CRCT,40AMP,ETA	TROLLING MOTOR	ETA
S06	028-0457	REF	SWITCH,SPST,CONT III	AERATOR	
	028-1019	1	BREAKER BOX	BREAKER BOX	
TB01		REF	HELM DC RETURN BUSS	DC RETURNS	
TM01		REF	TROLLING MOTOR	TROLLING MOTOR	

**FOUR WINNS WIRE LIST**

COLOR	GA	FIRST	PIN	TERM	NOTE	SECOND	PIN	TERM	NOTE	FUNCTION
RED	8	BT1	+	25		CB01	LINE	24		12V FEED
RED	8	CB01	LOAD	24		TM01	RED	51		12V FEED
BLK	8	BT1	-	25		TM01	BLK	51		TROLLING MOTOR GROUND
BLK	16	TB01	3	02	BA	J20	1	42		AERATOR RET
BRN/WHT	16	S06	3	02	BA	J20	2	42		AERATOR

**FREEDOM  
FISH & SKI 12V TROLLING MOTOR  
HARNES ASSEMBLY**

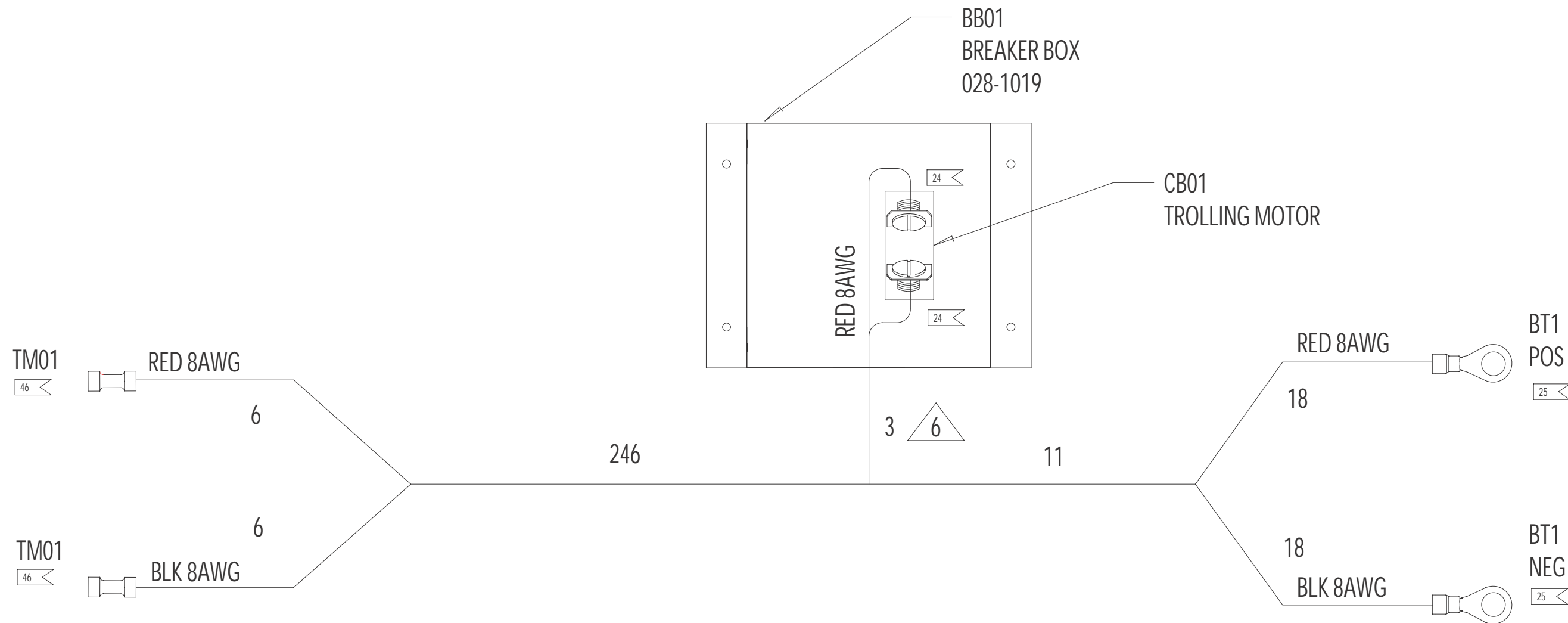

### FOUR WINNS PARTS LIST

ITEM	PART NUMBER	QUANTITY	DESCRIPTION	FUNCTION	MANUFACTURER
-	028-0315	2	TERM,RING,1/4,8	24	AMP
-	028-0211	2	CONNECTOR,BUTT,8 GA	46	AMP
-	028-0316	2	TERM,RING,3/8,8 GA	25	AMP
CB01	028-1883	1	BREAKER,40AMP,ETA#413-K54-FN2-40A	TROLLING MOTOR	ETA
BB01	028-1019	1	BREAKER BOX	BREAKER BOX	-
BT1	-	REF	BATTERY	TROLLING MOTOR BATTERY	-
TM01	-	REF	TROLLING MOTOR	TROLLING MOTOR	-

**170 HORIZON FISH & SKI I/O  
TROLLING MOTOR JUMPER  
HARNESS ASSEMBLY**

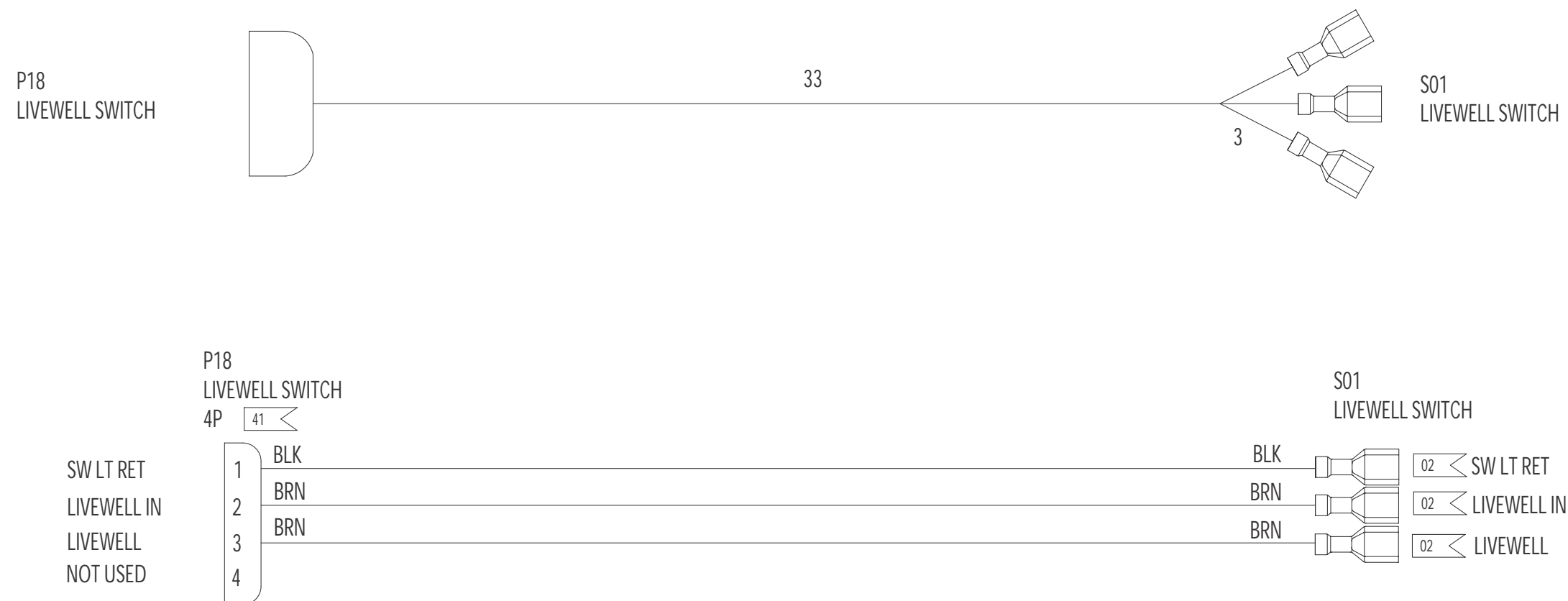

## FOUR WINNS PARTS LIST

ITEM	PART NUMBER	QUANTITY	DESCRIPTION	FUNCTION	MANUFACTURER
-	028-0177	3	RECEPT,FASTON,250,16-14	02	AMP
-	028-0390	3	PIN,UMNL,18-14	41	AMP
P18	028-0445	1	PLUG,UMNL,4 CKT	LIVEWELL	AMP
S01	028-0457	REF	SWITCH, SPST,ON-OFF	LIVEWELL SWITCH	CARLINGSWITCH

**170 HORIZON FISH & SKI I/O  
LIVEWELL SWITCH JUMPER  
HARNESS ASSEMBLY**

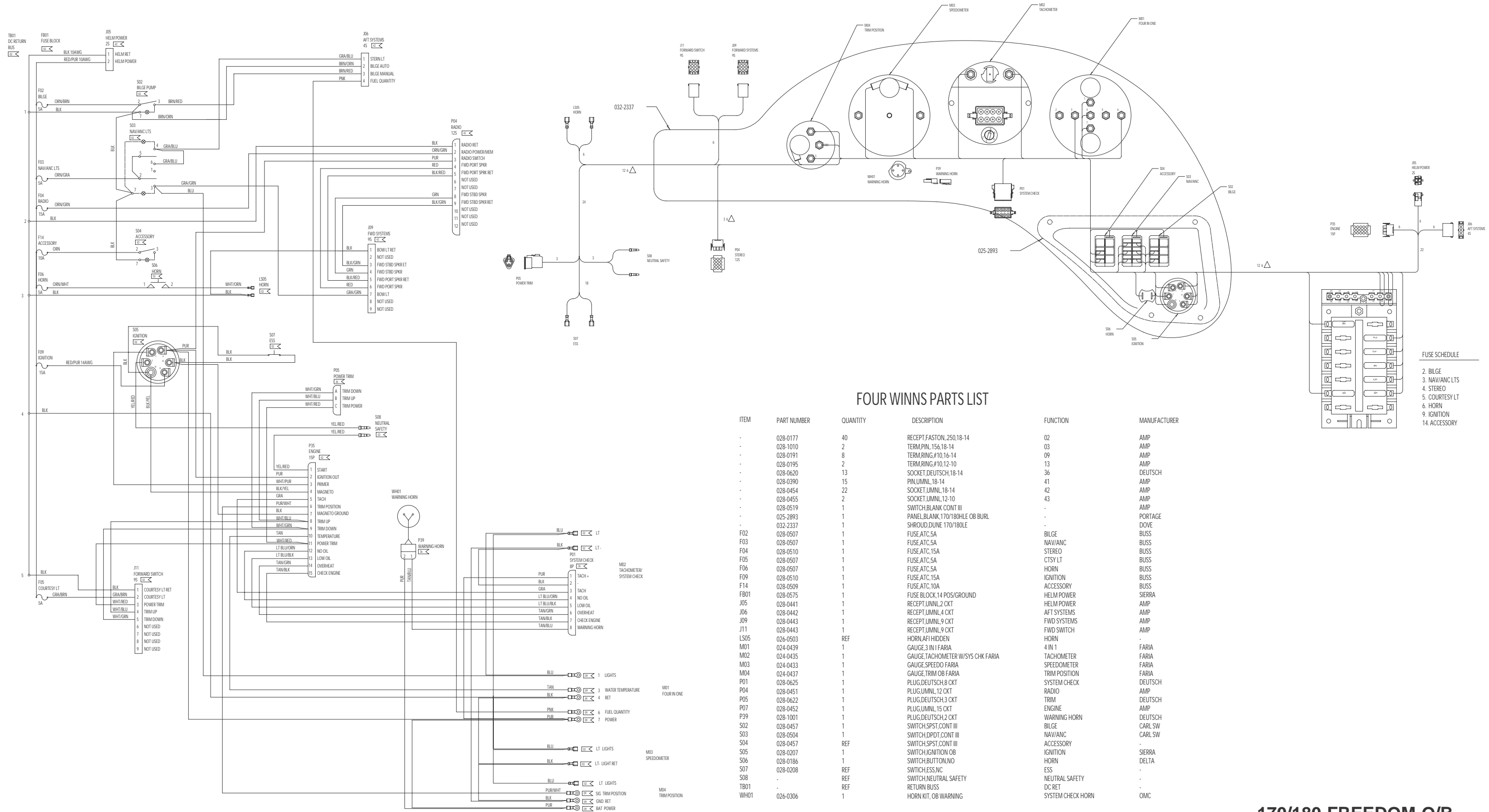

FOUR WINNS PARTS LIST

ITEM	PART NUMBER	QUANTITY	DESCRIPTION	FUNCTION	MANUFACTURER
-	028-0177	40	RECEPT,FASTON_250,18-14	02	AMP
-	028-1010	2	TERM,PIN_156,18-14	03	AMP
-	028-0191	8	TERM,RING,#10,16-14	09	AMP
-	028-0195	2	TERM,RING,#10,12-10	13	AMP
-	028-0620	13	SOCKET,DEUTSCH,18-14	36	DEUTSCH
-	028-0390	15	PIN,UMNL,18-14	41	AMP
-	028-0454	22	SOCKET,UMNL,18-14	42	AMP
-	028-0455	2	SOCKET,UMNL,12-10	43	AMP
-	028-0519	1	SWITCH,BLANK CONT III	-	AMP
-	025-2893	1	PANEL,BLANK,170/180HLE OB BURL	-	PORTAGE
-	032-2337	1	SHROUD,DUNE,170/180LE	-	DOVE
F02	028-0507	1	FUSE,ATC,5A	BILGE	BUSS
F03	028-0507	1	FUSE,ATC,5A	NAV/ANC	BUSS
F04	028-0510	1	FUSE,ATC,15A	STEREO	BUSS
F05	028-0507	1	FUSE,ATC,5A	CTSY LT	BUSS
F06	028-0507	1	FUSE,ATC,5A	HORN	BUSS
F09	028-0510	1	FUSE,ATC,15A	IGNITION	BUSS
F14	028-0509	1	FUSE,ATC,10A	ACCESSORY	BUSS
FB01	028-0575	1	FUSE,BLOCK,14 POS/GROUND	HELM POWER	SIERRA
J05	028-0441	1	RECEPT,UMNL,2 CKT	HELM POWER	AMP
J06	028-0442	1	RECEPT,UMNL,4 CKT	AFT SYSTEMS	AMP
J09	028-0442	1	RECEPT,UMNL,9 CKT	FWD SYSTEMS	AMP
J11	028-0443	1	RECEPT,UMNL,9 CKT	FWD SWITCH	AMP
LS05	026-0503	REF	HORN,AFT HIDDEN	HORN	-
M01	024-0439	1	GAUGE,3 IN I FARIA	4 IN 1	FARIA
M02	024-0435	1	GAUGE,TACHOMETER W/SYS CHK FARIA	TACHOMETER	FARIA
M03	024-0433	1	GAUGE,SPEEDO FARIA	SPEEDOMETER	FARIA
M04	024-0437	1	GAUGE,TRIM OB FARIA	TRIM POSITION	FARIA
P01	028-0625	1	PLUG,DEUTSCH,8 CKT	SYSTEM CHECK	DEUTSCH
P04	028-0451	1	PLUG,UMNL,12 CKT	RADIO	AMP
P05	028-0422	1	PLUG,DEUTSCH,3 CKT	TRIM	DEUTSCH
P07	028-0452	1	PLUG,UMNL,15 CKT	ENGINE	AMP
P39	028-1001	1	PLUG,DEUTSCH,2 CKT	WARNING HORN	DEUTSCH
S02	028-0457	1	SWITCH,SPST,CONT III	BILGE	CARL SW
S03	028-0504	1	SWITCH,DPST,CONT III	NAV/ANC	CARL SW
S04	028-0457	REF	SWITCH,SPST,CONT III	ACCESSORY	-
S05	028-0207	1	SWITCH,IGNITION OB	IGNITION	SIERRA
S06	028-0186	1	SWITCH,BUTTON,NO	HORN	DELTA
S07	028-0208	REF	SWITCH,ESS,NC	ESS	-
S08	-	REF	SWITCH,NEUTRAL SAFETY	NEUTRAL SAFETY	-
TB01	-	REF	RETURN BUSS	DC RET	-
WH01	026-0306	1	HORN,KIT,OB WARNING	SYSTEM CHECK HORN	OMC

170/180 FREEDOM O/B INSTRUMENTATION PANEL ASSEMBLY

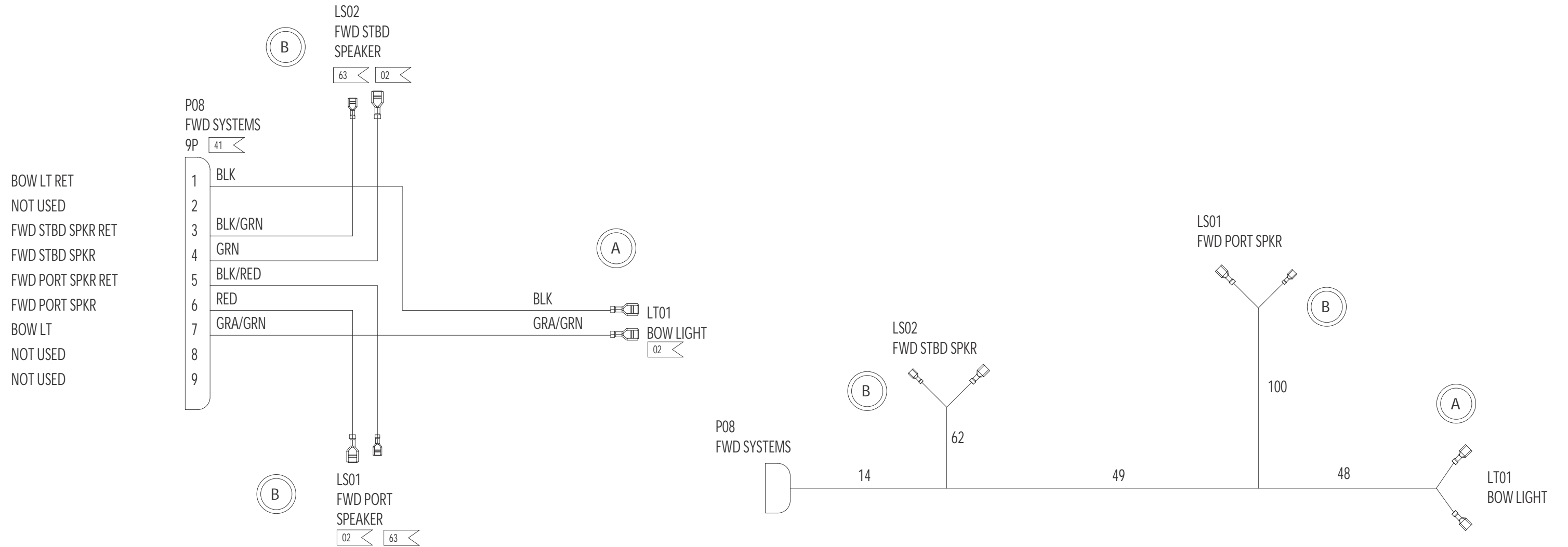

### FOUR WINNS PARTS LIST

ITEM	PART NUMBER	QUANTITY	DESCRIPTION	FUNCTION	MANUFACTURER
-	028-0177	4	RECEPT,FASTON,,250,18-14	02	AMP
-	028-0390	6	PIN,UMNL,18-14	41	AMP
-	028-1288	2	RECEPT,FASTON,,205	63	AMP
LS01	-	REF	SPEAKER	FWD PORT SPKR	-
LS02	-	REF	SPEAKER	FWD STBD SPKR	-
LT01	-	REF	LIGHT, NAV, 2 MILE	NAV LIGHT	-
P08	028-0449	1	PLUG,UMNL,9 CKT	FWD SYSTEMS	AMP

**170/180 FREEDOM O/B  
FORWARD SYSTEMS  
HARNESS ASSEMBLY**



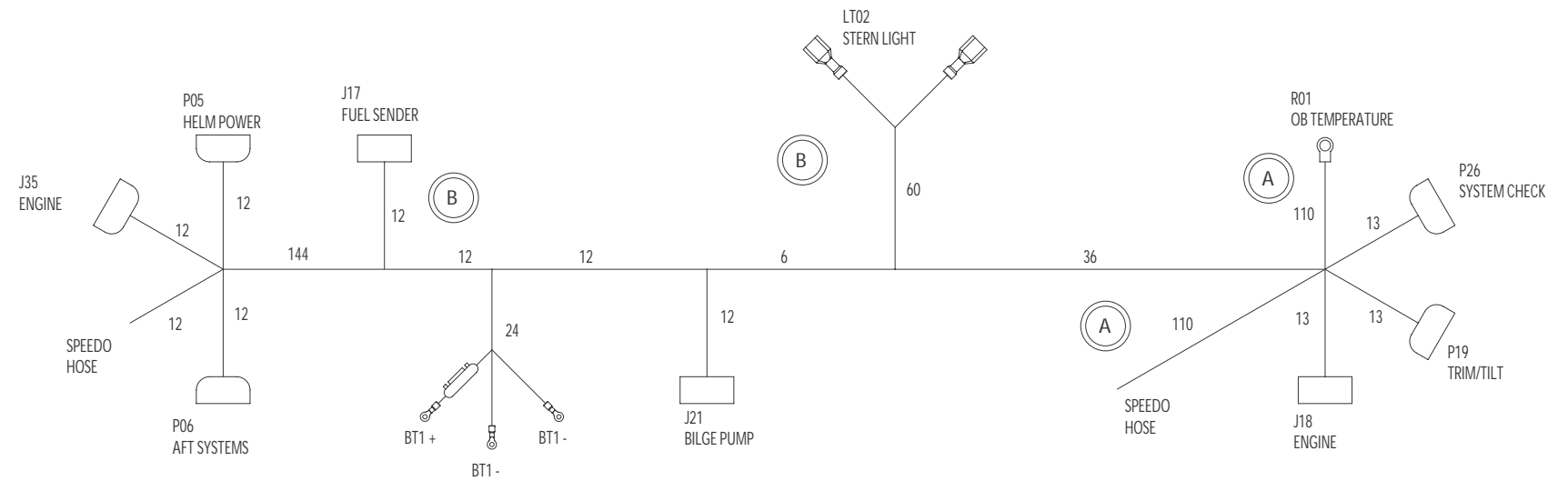
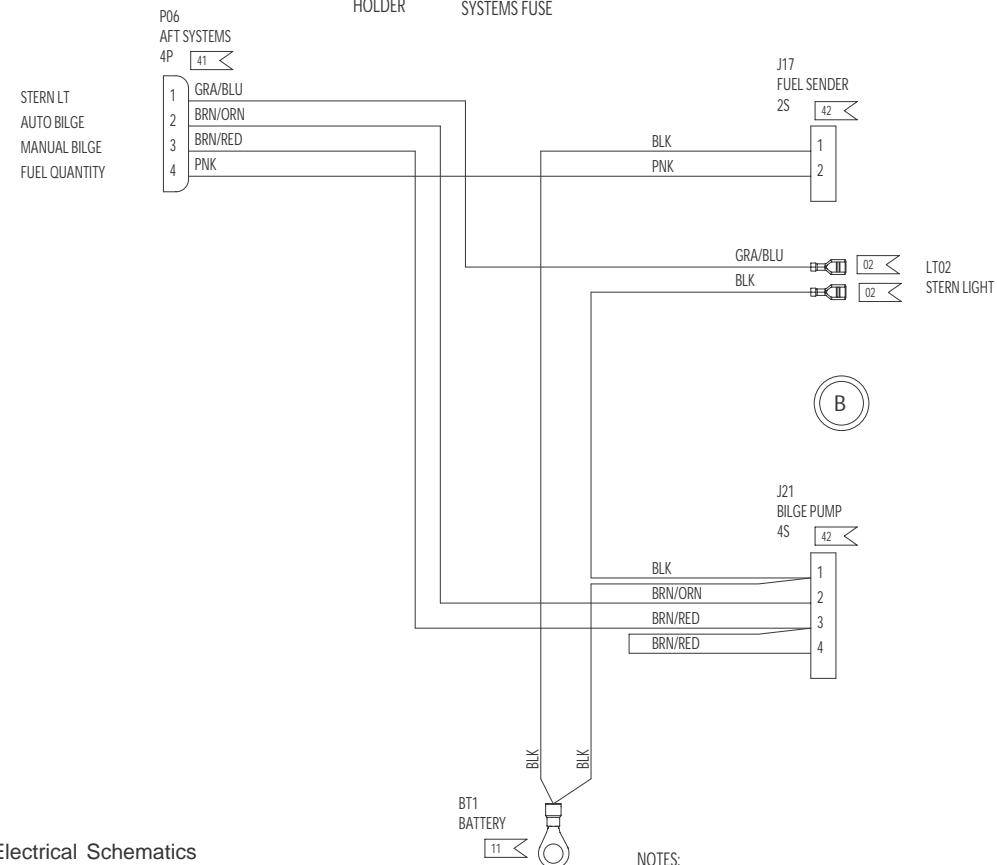
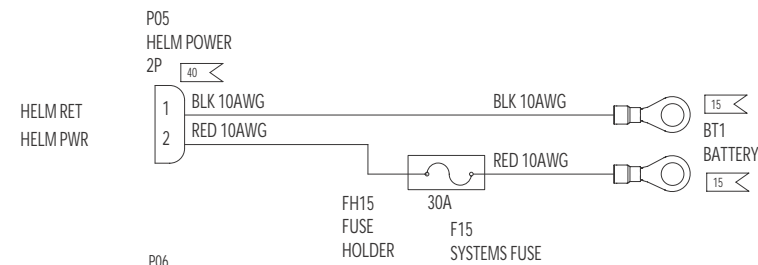
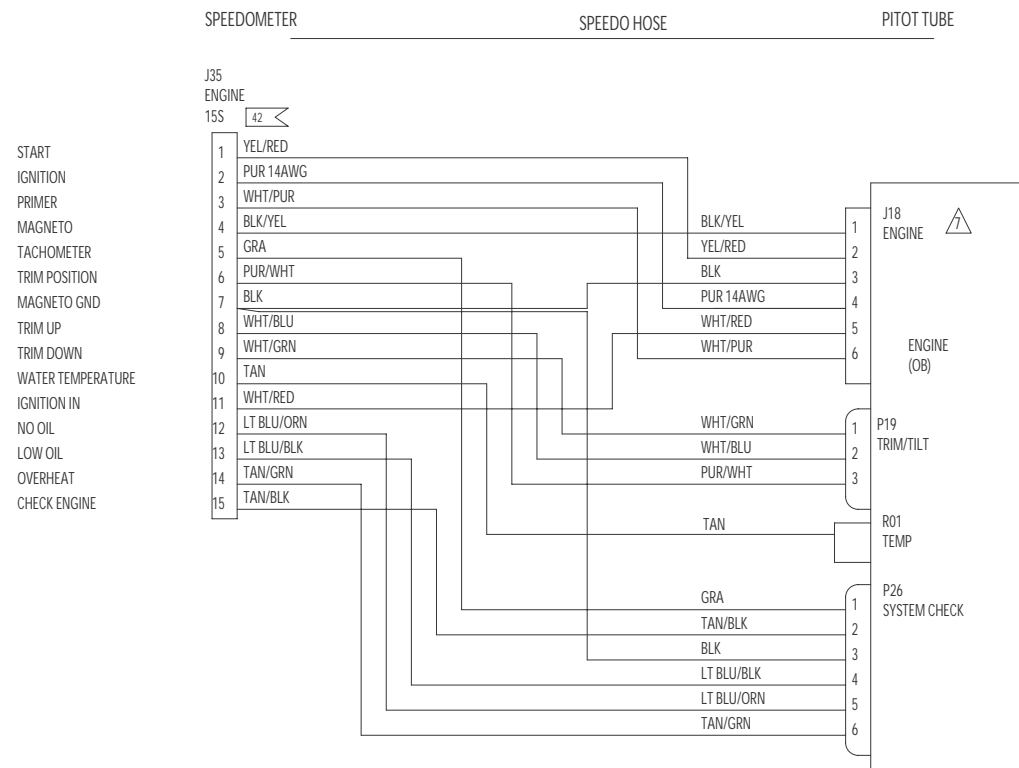

## FOUR WINNS PARTS LIST

ITEM	PART NUMBER	QUANTITY	DESCRIPTION	FUNCTION	MANUFACTURER
	028-0177	6	TERM,FASTON,,250,18-14	02	AMP
	028-0191	1	TERM,RING,#10,18-14	09	AMP
	028-0197	3	TERM,RING,3/8,12-10	15	AMP
	028-0620	9	SOCKET,DEUTSCH,18-16	36	DEUTSCH
	028-0626	6	PIN,DEUTSCH,18-16	38	DEUTSCH
	028-0453	2	PIN,UMNL,12-10	40	AMP
	028-0390	9	PIN,UMNL,18-14	41	AMP
	028-0454	22	SOCKET,UMNL,18-14	42	AMP
BT1	-	REF	BATTERY,HD24-DP	SYSTEM BATTERY	
FH15	-	1	FUSEHOLDER, SEALED	FUSEHOLDER	PACKARD
HS01	024-0073	1	HOSE,SPEEDOMETER OMC	SPEEDOMETER HOSE	OMC
J17	028-0441	1	RECEPT,UMNL,2 CKT	FUEL SENDER	AMP
J18	028-0623	1	RECEPT,DEUTSCH,6 CKT	ENGINE	AMP
J21	028-0442	1	RECEPT,UMNL,4 CKT	BILGE PUMP	AMP
J35	028-0446	1	RECEPT,UMNL,15 CKT	ENGINE	AMP
LT02	-	REF	BASE,STERN L	STERN LT BASE	-
P05	028-0447	1	PLUG,UMNL,2 CKT	HELM POWER	AMP
P06	028-0448	1	PLUG,UMNL,4 CKT	AFT SYSTEMS	AMP
P19	028-0622	1	PLUG,DEUTSCH,3 CKT	TRIM	AMP
P26	028-0624	1	PLUG,DEUTSCH,6 CKT	ENGINE	AMP
R01	-	REF	SENDER,WATER TEMP	WATER TEMP SENDER	-

## 170/180 FREEDOM O/B AFT SYSTEMS HARNES ASSEMBLY

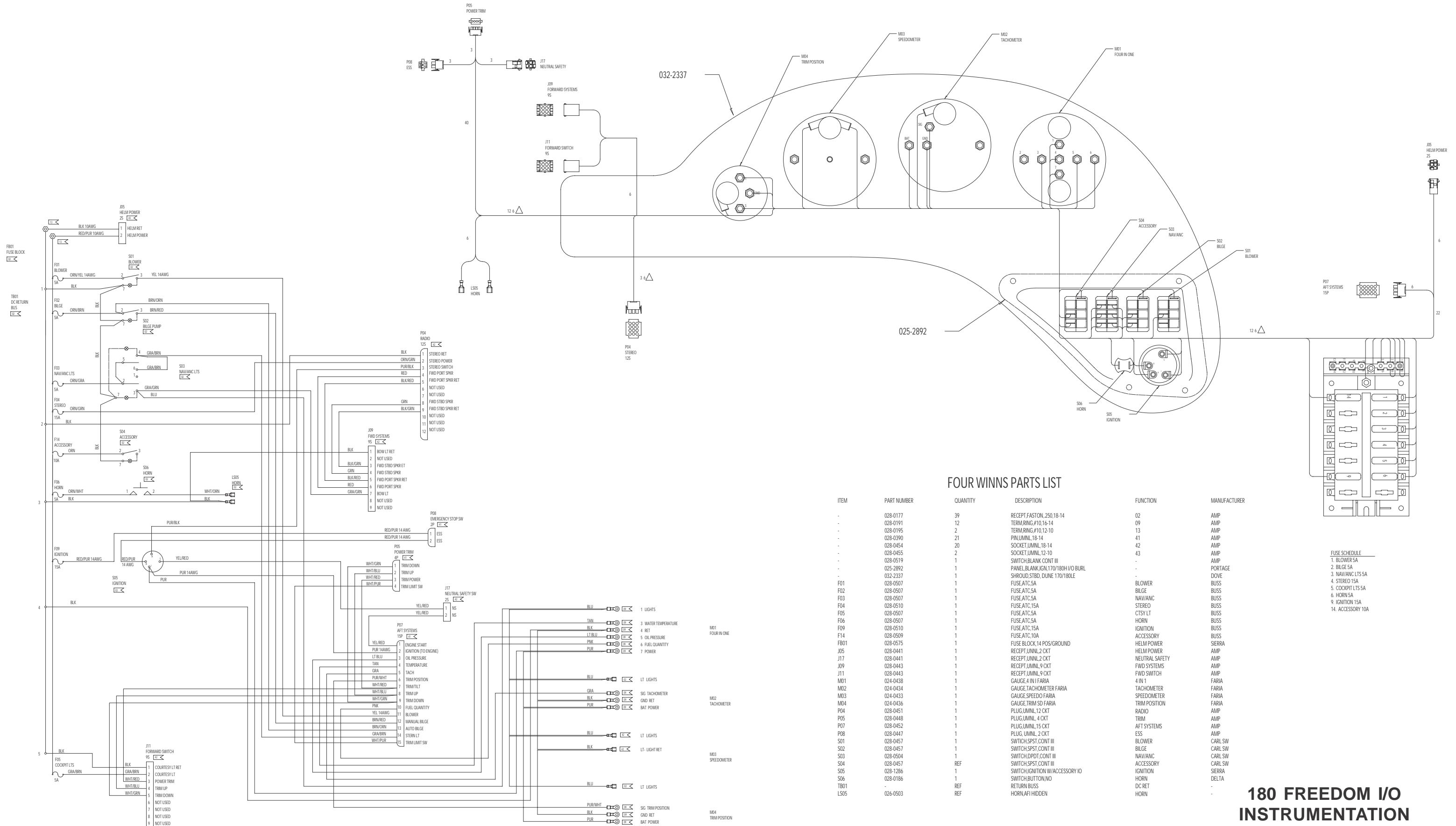

FOUR WINNS PARTS LIST

ITEM	PART NUMBER	QUANTITY	DESCRIPTION	FUNCTION	MANUFACTURER
-	028-0177	39	RECEPT.FASTON,250,18-14	02	AMP
-	028-0191	12	TERMRING,#10,16-14	09	AMP
-	028-0195	2	TERMRING,#10,12-10	13	AMP
-	028-0390	21	PIN,UMNL,18-14	41	AMP
-	028-0454	20	SOCKET,UMNL,18-14	42	AMP
-	028-0455	2	SOCKET,UMNL,12-10	43	AMP
-	028-0519	1	SWITCH,BLANK,CONT III	-	AMP
-	025-2892	1	PANEL,BLANK,IGN,170/180H I/O BURL	-	PORTAGE
-	032-2337	1	SHROUD,STBD, DUNE 170/180LE	-	DOVE
F01	028-0507	1	FUSE,ATC,5A	BLOWER	BUSS
F02	028-0507	1	FUSE,ATC,5A	BILGE	BUSS
F03	028-0507	1	FUSE,ATC,5A	NAVI/ANC	BUSS
F04	028-0510	1	FUSE,ATC,15A	STEREO	BUSS
F05	028-0507	1	FUSE,ATC,5A	CTSY LT	BUSS
F06	028-0507	1	FUSE,ATC,5A	HORN	BUSS
F09	028-0510	1	FUSE,ATC,15A	IGNITION	BUSS
F14	028-0509	1	FUSE,ATC,10A	ACCESSORY	BUSS
FB01	028-0575	1	FUSE BLOCK,14 POS/GROUND	HELM POWER	SIERRA
J05	028-0441	1	RECEPT,UMNL,2 CKT	HELM POWER	AMP
J17	028-0441	1	RECEPT,UMNL,2 CKT	NEUTRAL SAFETY	AMP
J09	028-0443	1	RECEPT,UMNL,9 CKT	FWD SYSTEMS	AMP
J11	028-0443	1	RECEPT,UMNL,9 CKT	FWD SWITCH	AMP
M01	024-0438	1	GAUGE,4 IN I FARIA	4 IN 1	FARIA
M02	024-0434	1	GAUGE,TACHOMETER FARIA	TACHOMETER	FARIA
M03	024-0433	1	GAUGE,SPEEDO FARIA	SPEEDOMETER	FARIA
M04	024-0436	1	GAUGE,TRIM SD FARIA	TRIM POSITION	FARIA
P04	028-0451	1	PLUG,UMNL,12 CKT	RADIO	AMP
P05	028-0448	1	PLUG,UMNL,4 CKT	TRIM	AMP
P07	028-0452	1	PLUG,UMNL,15 CKT	AFT SYSTEMS	AMP
P08	028-0447	1	PLUG,UMNL,2 CKT	ESS	AMP
S01	028-0457	1	SWITCH,SPST,CONT III	BLOWER	CARL SW
S02	028-0457	1	SWITCH,SPST,CONT III	BILGE	CARL SW
S03	028-0504	1	SWITCH,DPDT,CONT III	NAVI/ANC	CARL SW
S04	028-0457	REF	SWITCH,SPST,CONT III	ACCESSORY	CARL SW
S05	028-1286	1	SWITCH,IGNITION W/ACCESSORY IO	IGNITION	SIERRA
S06	028-0186	1	SWITCH,BUTTON,NO	HORN	DELTA
TB01	-	REF	RETURN BUSS	DC RET	-
LS05	026-0503	REF	HORN,AFI,HIDDEN	HORN	-

FUSE SCHEDULE  
 1. BLOWER 5A  
 2. BILGE 5A  
 3. NAVI/ANC LTS 5A  
 4. STEREO 15A  
 5. COCKPIT LTS 5A  
 6. HORN 5A  
 9. IGNITION 15A  
 14. ACCESSORY 10A

180 FREEDOM I/O INSTRUMENTATION PANEL ASSEMBLY

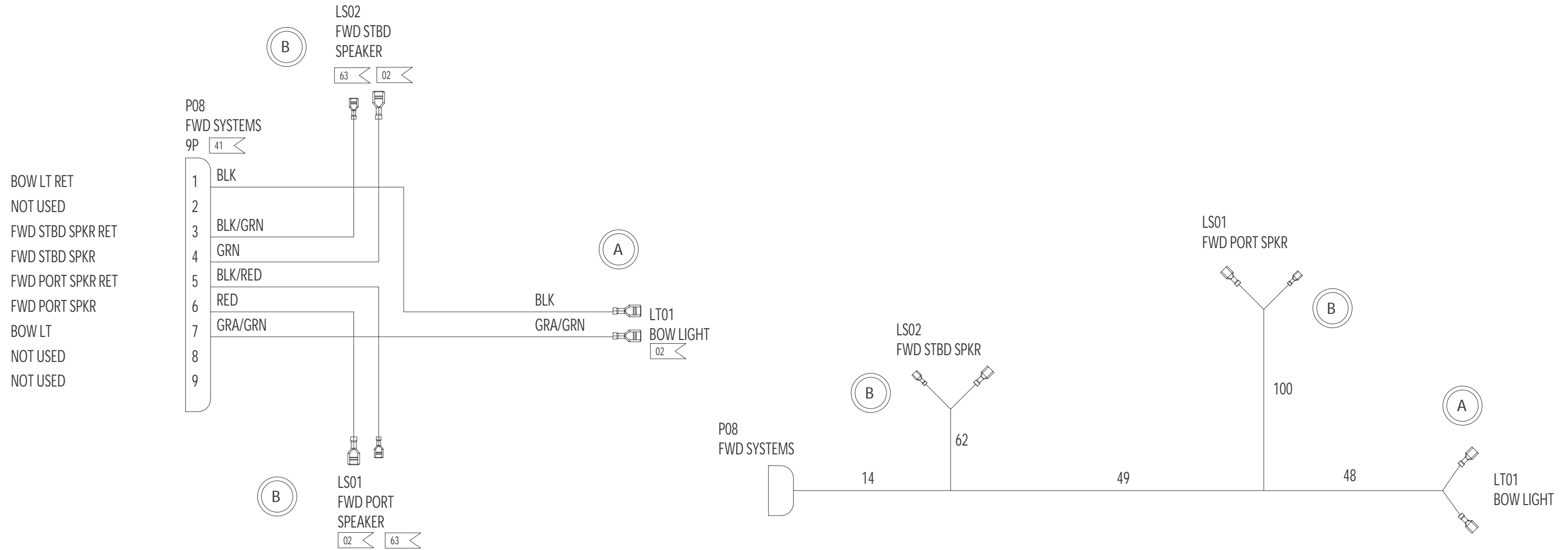

### FOUR WINNS PARTS LIST

ITEM	PART NUMBER	QUANTITY	DESCRIPTION	FUNCTION	MANUFACTURER
-	028-0177	4	RECEPT,FASTON,,250,18-14	02	AMP
-	028-0390	6	PIN,UMNL,18-14	41	AMP
-	028-1288	2	RECEPT,FASTON,,205	63	AMP
LS01	-	REF	SPEAKER	FWD PORT SPKR	-
LS02	-	REF	SPEAKER	FWD STBD SPKR	-
LT01	-	REF	LIGHT, NAV, 2 MILE	NAV LIGHT	-
P08	028-0449	1	PLUG,UMNL,9 CKT	FWD SYSTEMS	AMP

**180 FREEDOM I/O  
FORWARD SYSTEMS  
HARNESS ASSEMBLY**

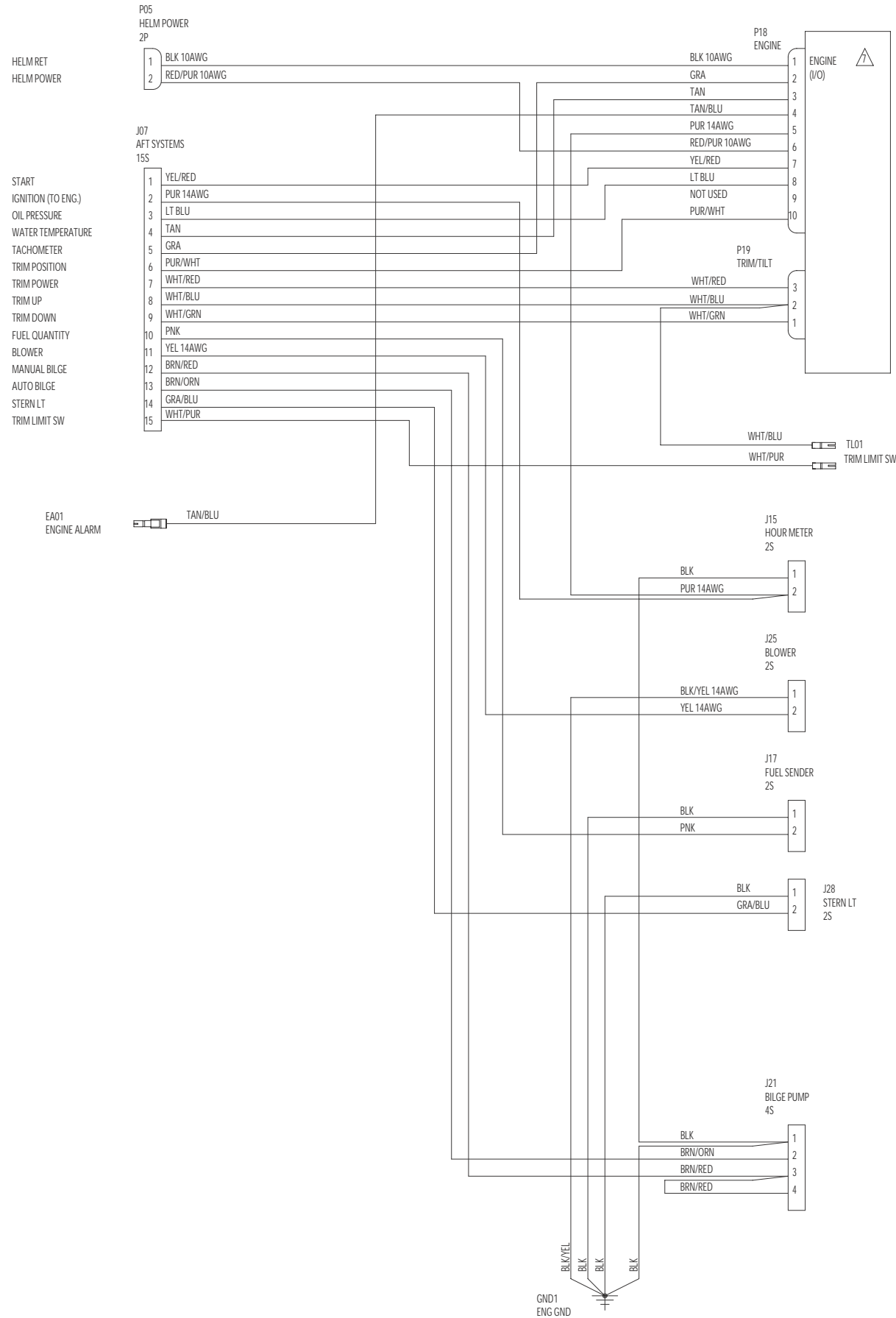

SPEEDOMETER HOSE PITOT TUBE

**FOUR WINNS PARTS LIST**

ITEM	PART NUMBER	QUANTITY	DESCRIPTION	FUNCTION	MANUFACTURER
	028-0197	1	TERM,RING,3/8",12-10	15	AMP
	028-0453	2	PIN,UMNL,12-10	40	AMP
	028-0454	25	SOCKET,UMNL,18-14	42	AMP
	028-0211	2	RECEPT, SOCKET,156,16-14	46	AMP
	028-1823	1	TERM,BULLETT,FEMALE,INS,156,16-14	75	MOLEX
GND1		REF	ENGINE GROUND	ENGINE GROUND	
HS01	024-0073	1	HOSE,SPEEDOMETER,C1101033	SPEEDOMETER	NEW AGE
J07	028-0446	1	RECEPT,UMNL,15 CKT	AFT SYSTEMS	AMP
J15	028-0441	1	RECEPT,UMNL,2 CKT	HOUR METER	AMP
J17	028-0441	1	RECEPT,UMNL,2 CKT	FUEL SENDER	AMP
J21	028-0442	1	RECEPT,UMNL,4 CKT	BILGE PUMP	AMP
J25	028-0441	1	RECEPT,UMNL,2 CKT	BLOWER	AMP
J28	028-0441	1	RECEPT,UMNL,2 CKT	STERN LT	AMP
P05	028-0447	1	PLUG,UMNL,2 CKT	HELM POWER	AMP
P18		1	PLUG,ENGINE I/O	ENGINE	OMC
P19		1	PLUG,TRIM/TILT	TRIM/TILT	OMC
EA01		REF	ENGINE ALARM		

**FOUR WINNS WIRE LIST**

COLOR	GA	FIRST	PIN	TERM	NOTE	SECOND	PIN	TERM	NOTE	FUNCTION
-	-	-	-	-	-	-	-	-	-	-
BLK	16	J21	1	42	SJ	GND1	1	15	SG	BILGE RET
BLK	16	J28	1	42		GND1	1	15	SG	STERN LIGHT RET
BLK	10	P05	1	40		P18	1	51		12 V RETURN
BLK	16	J17	1	42		GND1	1	15	SG	FUEL SENDER RET
BLK/YEL	14	J25	1	42		GND1	1	15	SG	BLOWER RET
BLK	16	J15	1	42		J21	1	42	SJ	HOUR METER RET
BRN/ORN	16	J07	13	42		J21	2	42		BILGE AUTO
BRN/RED	16	J07	12	42		J21	3	42	SI	BILGE MANUAL
GRA	16	J07	5	42		P18	2	51		TACH
GRA/BLU	16	J07	14	42		J28	2	42		STERN LIGHT
LT BLU	16	J07	3	42		P18	8	51		OIL PRESSURE
PNK	16	J07	10	42		J17	2	42		FUEL QUANTITY
PUR	14	J07	2	42	SF	J15	2	42		HOUR METER
PUR	14	J15	2	42	SA	P18	5	51	SA	IGNITION
PUR/WHT	16	J07	6	42		P18	10	51		TRIM POSITION
RED/PUR	10	P05	2	40		P18	6	51		12 V FEED
TAN	16	J07	4	42		P18	3	51		TEMP
WHT/BLU	16	J07	8	42		P19	2	51	SK	TRIM UP
WHT/BLU	16	P19	2	51	SK	TL01	-	46		TRIM LIMIT SW
WHT/GRN	16	J07	9	42		P19	1	51		TRIM DOWN
WHT/RED	16	J07	7	42		P19	3	51		TRIM/TILT
YEL	14	J07	11	42		J25	2	42		BLOWER
YEL/RED	16	J07	1	42	SI	P18	7	51		ENGINE START
BRN/RED	16	J21	3	42		J21	4	42		AUTO BILGE JUMPER
WHT/PUR	16	J07	15	42		TL01	-	46		TRIM LIMIT SW
TAN/BLU	16	P18	4	51		EA01	-	75		ENGINE ALARM

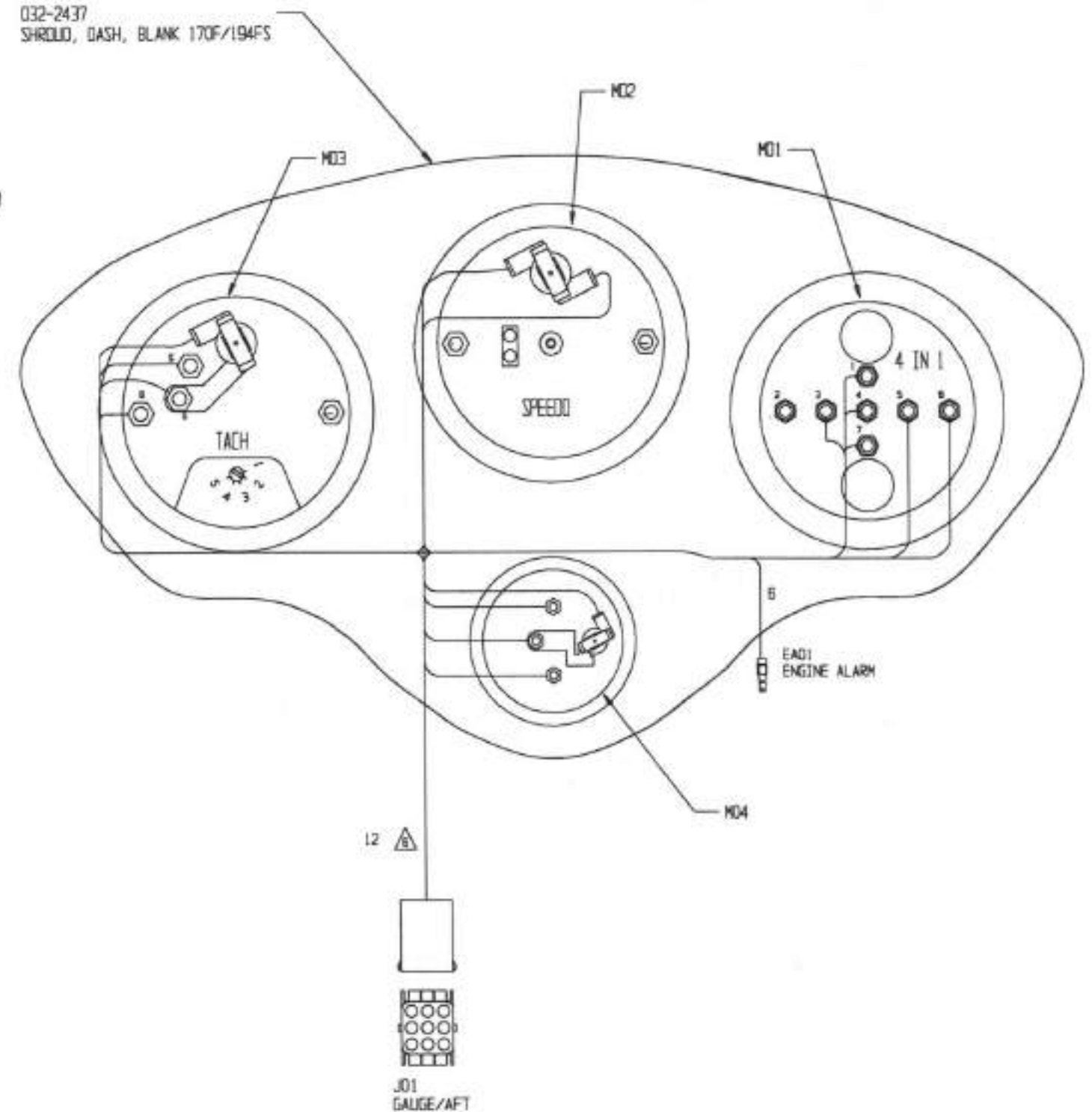
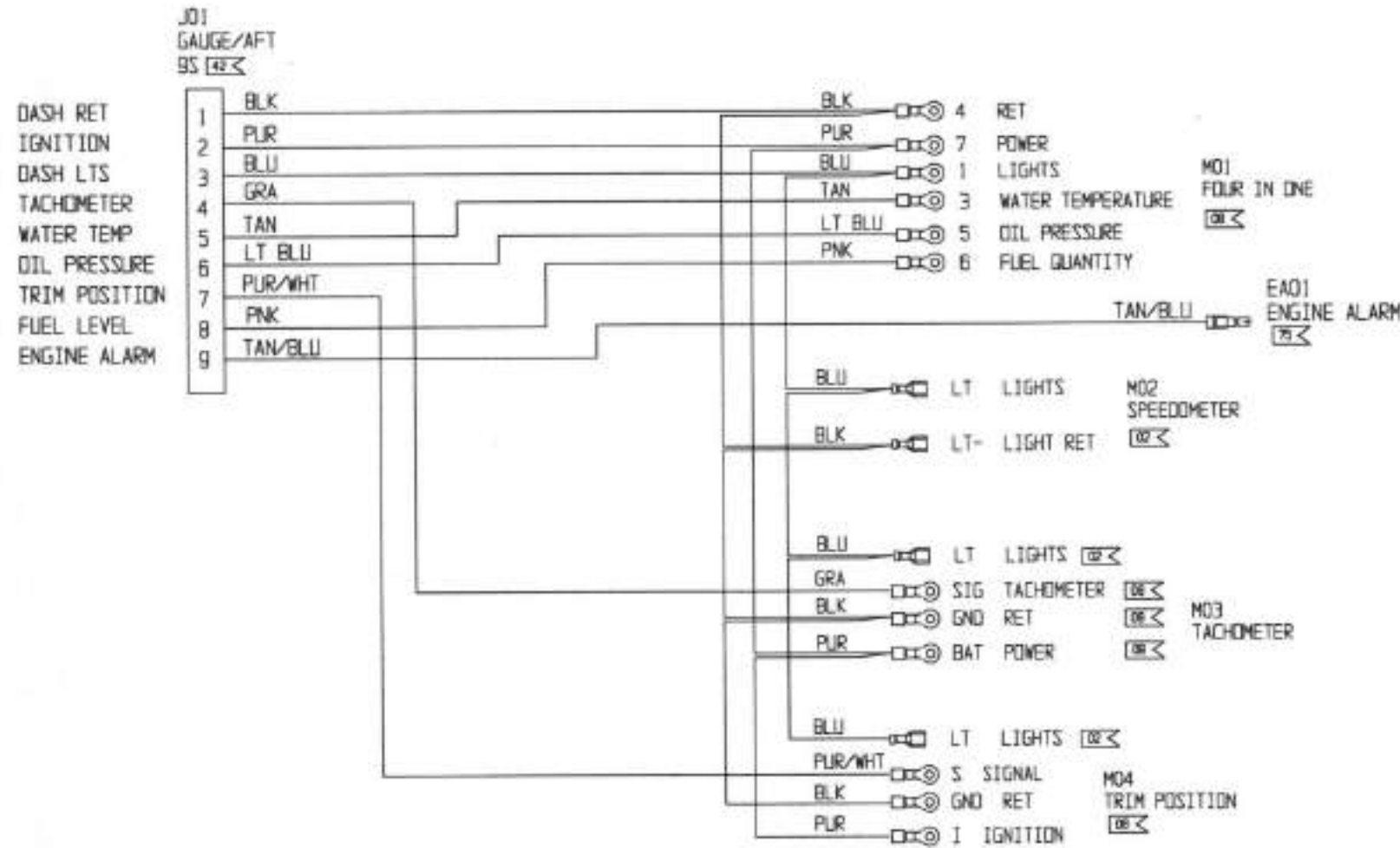

### FOUR WINNS PARTS LIST

ITEM	PART NUMBER	QUANTITY	DESCRIPTION	FUNCTION	MANUFACTURER
-	028-0454	4	RECEPT, FASTON, .250, 16-14	02	AMP
-	028-0189	12	TERM, RING, PG #8, 16-14	08	AMP
-	028-0177	9	SOCKET, UMNL, 18-14	42	AMP
-	028-1823	1	TERM, BULLET, FEMALE, INS, .156, 16-14	75	MOLEX
-	032-2437	1	SHROUD, DASH BLANK 170F/194FS	-	-
J01	028-0443	1	RECEPT, UMNL, 9 CKT	GAUGE/AFT	AMP
M01	024-0438	1	GAUGE, 4 IN 1, GF0002	-	FARIA
M02	024-0433	1	GAUGE, SPEED (50MPH), SE9473	-	FARIA
M03	024-0434	1	GAUGE, TACH (6000RPM), TC9679	-	FARIA
M04	024-0436	1	GAUGE, TRIM, GP9317	-	FARIA



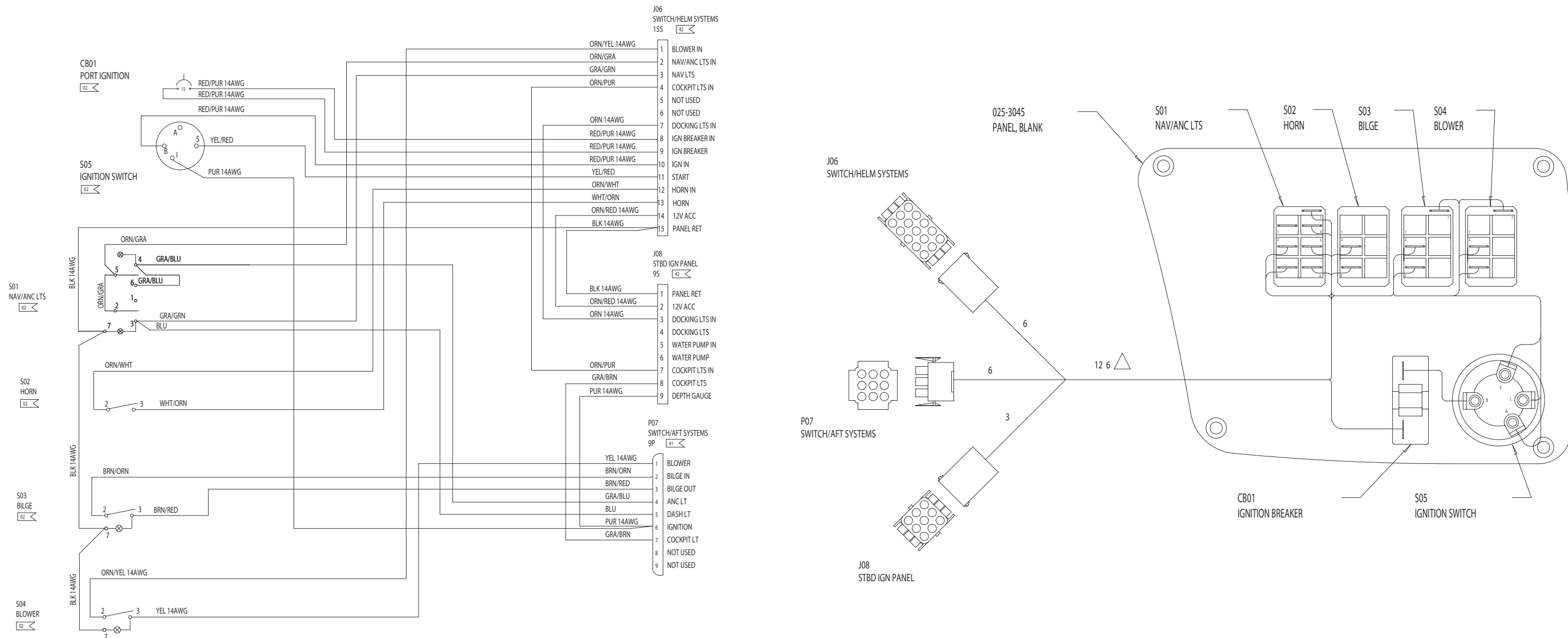

**FOUR WINNS PARTS LIST**

ITEM	PART NUMBER	QUANTITY	DESCRIPTION	FUNCTION	MANUFACTURER
-	028-0177	19	TERM,FASTON,.250,18-14	02	AMP
-	028-0390	7	PIN,UMNL,18-14	41	AMP
-	028-0454	19	SOCKET,UMNL,18-14	42	AMP
-	025-3045	1	PANEL,BLANK, PORT IGN SW	-	-
J06	028-0446	1	RECEPT,UMNL,15CKT	SWITCH/HELM	AMP
J08	028-0443	1	RECEPT,UMNL,9CKT	STBD IGN PANEL	AMP
P07	028-0449	1	PLUG,UMNL,9CKT	SWITCH AFT	AMP
CB01	028-0467	1	BREAKER,15A	IGNITION BREAKER	MP
S01	028-0504	1	SWITCH,DPDT,ON-OFF-ON,CONT III	NAV LTS	CARL SW
S02	028-0456	1	SWITCH,SPST,(ON)-OFF,CONT III	HORN	CARL SW
S03	028-0457	1	SWITCH,SPST,ON-OFF,CONT III	BILGE	CARL SW
S04	028-0457	1	SWITCH,SPST,ON-OFF,CONT III	BLOWER	CARL SW
S05	Ⓐ 028-1286	1	SWITCH,IGNITION,I/O	IGNITION SWITCH	GENERAL

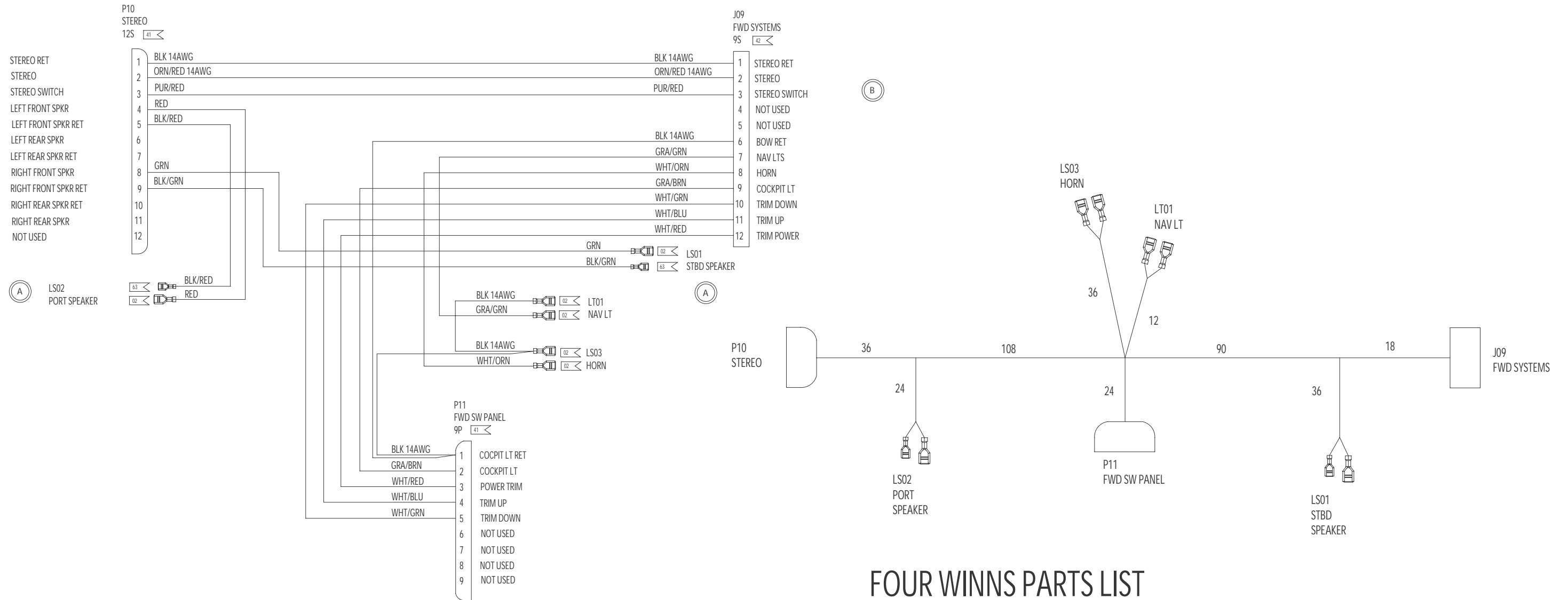

## FOUR WINNS PARTS LIST

ITEM	PART NUMBER	QUANTITY	DESCRIPTION	FUNCTION	MANUFACTURER
-	028-0177	6	RECEPT,FASTON,.250,16-14	02	AMP
-	028-0390	12	PIN,UMNL,18-14	41	AMP
-	028-0454	10	SOCKET,UMNL,18-14	42	AMP
-	028-1288	2	RECEPT,FASTON,.205,18-15	63	AMP
J09	028-0445	1	RECEPTACLE,UMNL,12 CKT	FWD SYSTEMS	AMP
P10	028-0451	1	PLUG,UMNL,12 CKT	STEREO	AMP
P11	028-0449	1	PLUG,UMNL,9 CKT	FWD SW PANEL	AMP

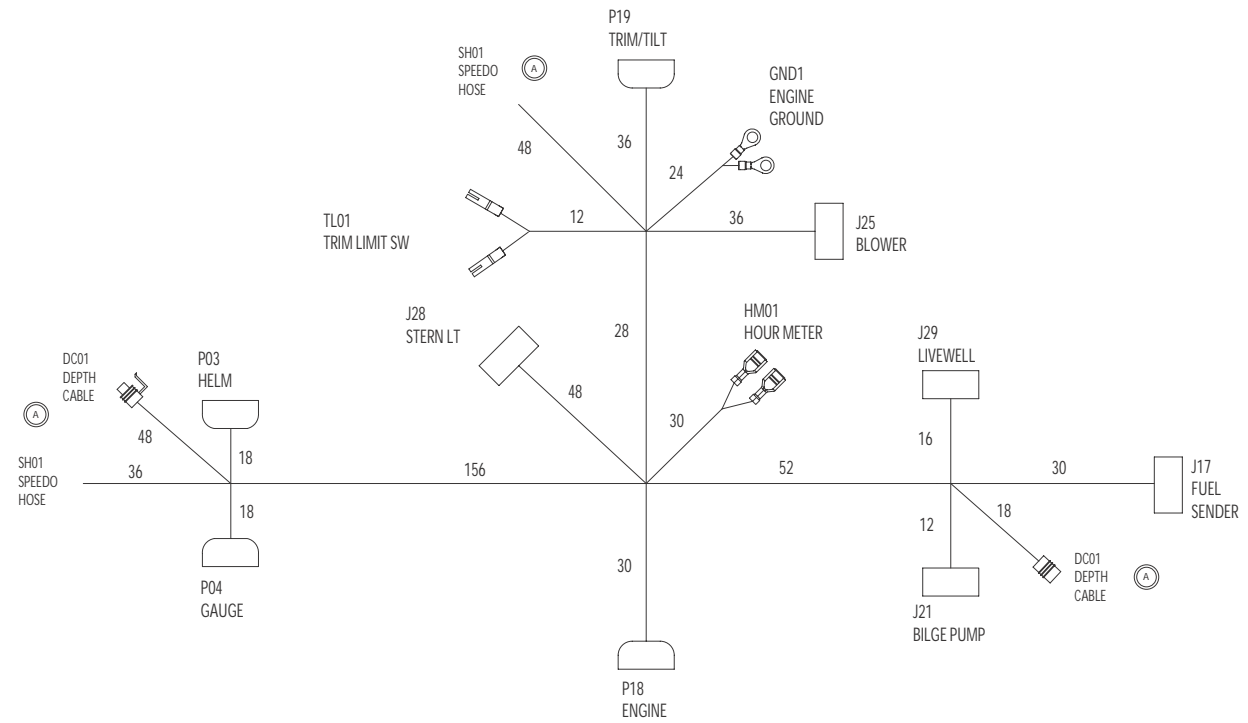
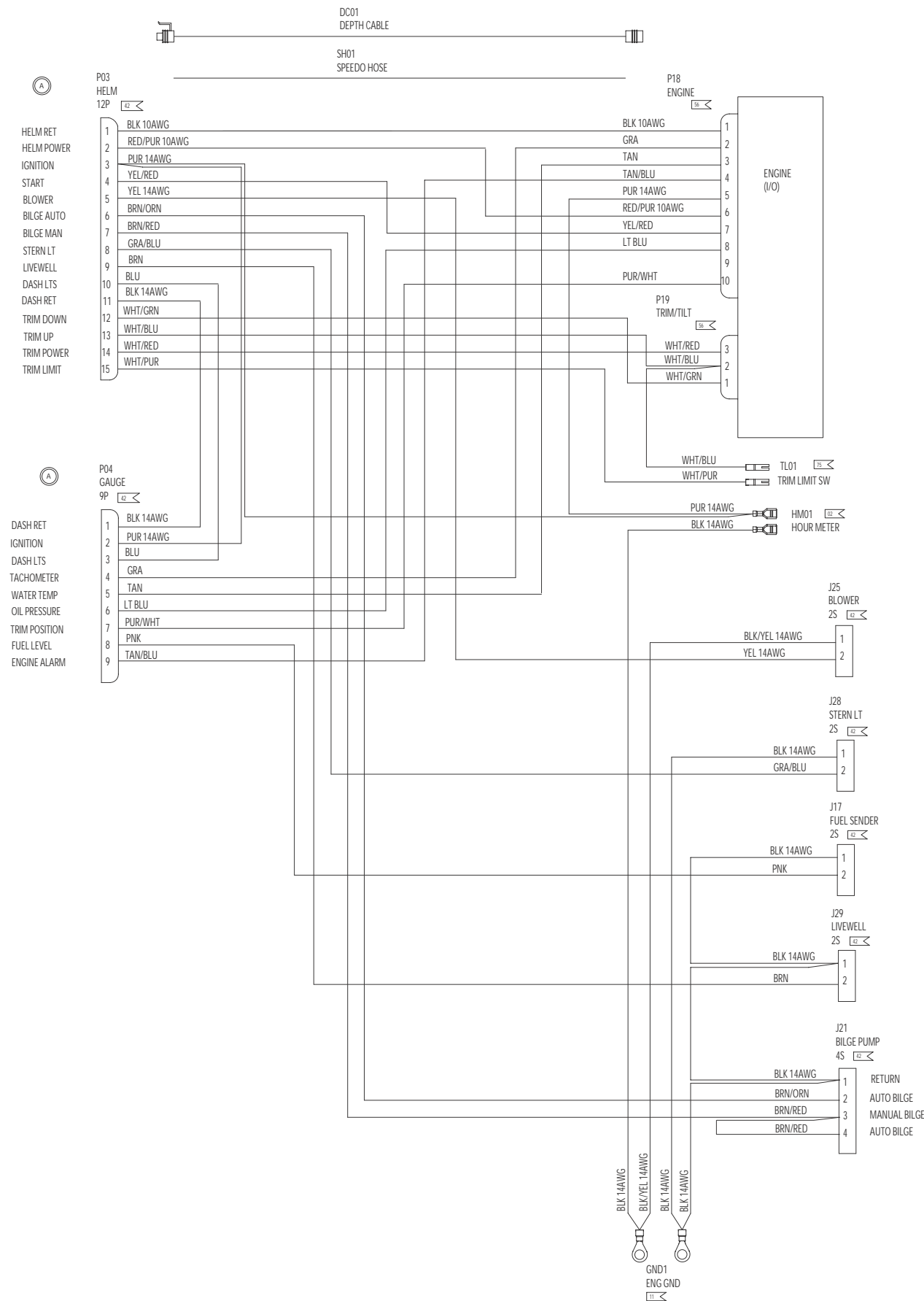

**FOUR WINNS PARTS LIST**

ITEM	PART NUMBER	QUANTITY	DESCRIPTION	FUNCTION	MANUFACTURER
-	028-0177	2	RECEPT.FASTON,250,16-14	02	AMP
-	028-0193	2	TERM.RING,3/8,16-14	11	AMP
-	028-0390	24	PIN,UMNL,18-14	41	AMP
-	028-0454	12	SOCKET,UMNL,18-14	42	AMP
-	028-1823	2	TERM.BULLET,FEMALE,INS,156,16-14	75	MOLEX
-	-	12	VENDER TERMINATION	51	-
GND1	-	REF	ENGINE GROUND	ENGINE GROUND	-
TL01	-	REF	TRIM LIMIT	TRIM LIMIT SW	-
HM01	-	REF	HOUR METER	HOUR METER	-
P03	028-0452	1	PLUG,UMNL,15 CKT	HELM/AFT	AMP
P04	028-0449	1	PLUG,UMNL,9 CKT	GAUGE/AFT	AMP
J17	028-0441	1	RECEPT,UMNL,2 CKT	FUEL SENDER	AMP
J21	028-0442	1	RECEPT,UMNL,4 CKT	BILGE PUMP	AMP
J25	028-0441	1	RECEPT,UMNL,2 CKT	BLOWER	AMP
J28	028-0441	1	RECEPT,UMNL,2 CKT	STERN LT	AMP
J29	028-0441	1	RECEPT,UMNL,2 CKT	LIVEWELL	AMP
P18	-	1	PLUG,ENGINE I/O	ENGINE	OMC
P19	-	1	PLUG,TRIM/TILT	TRIM/TILT	OMC
SH01	024-0013	1	SPEEDO HOSE,C1101033	SPEEDOMETER	NEW AGE
DC01	027-2199	1	TRANSDUCER CABLE,23',#HN0337	DEPTH GAUGE	FARIA/TALON

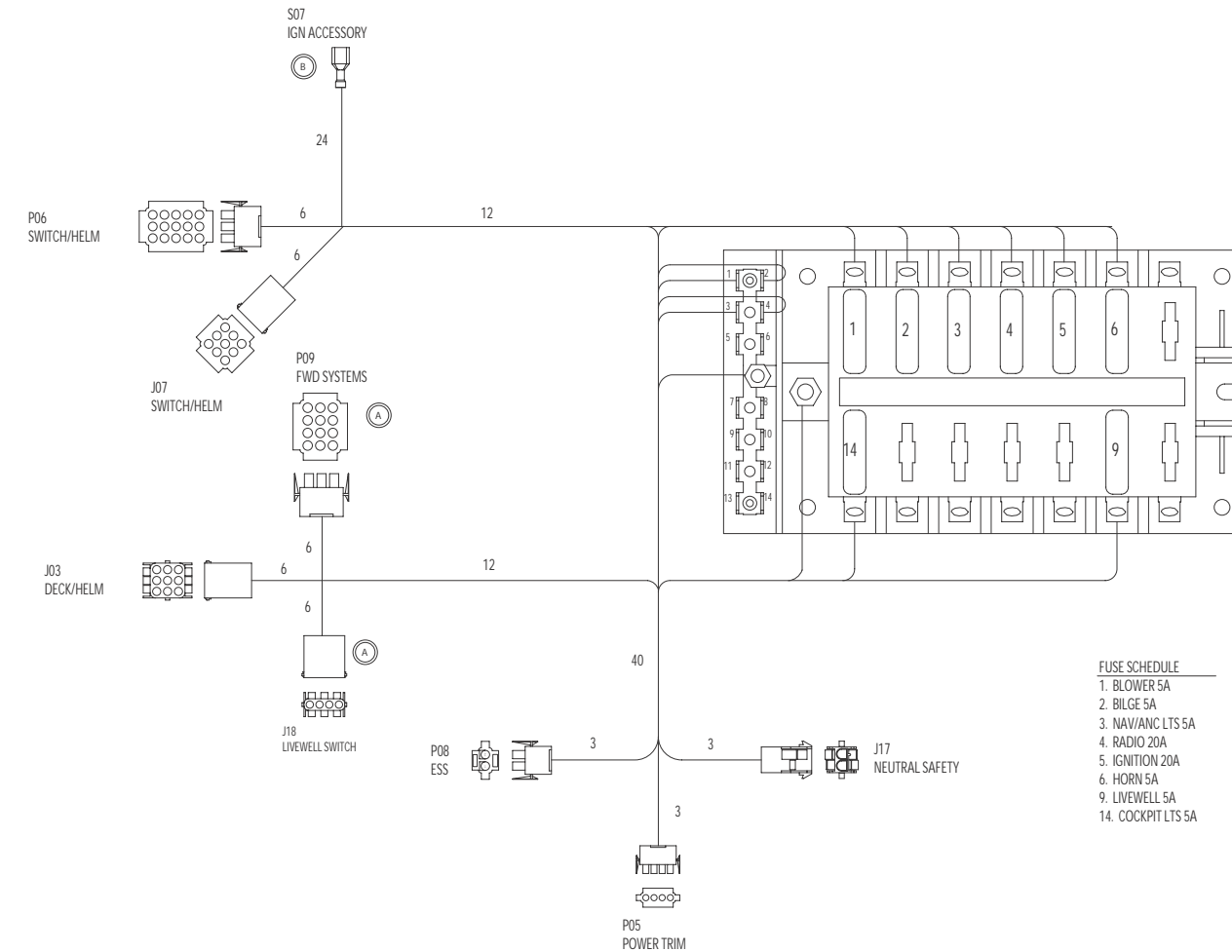
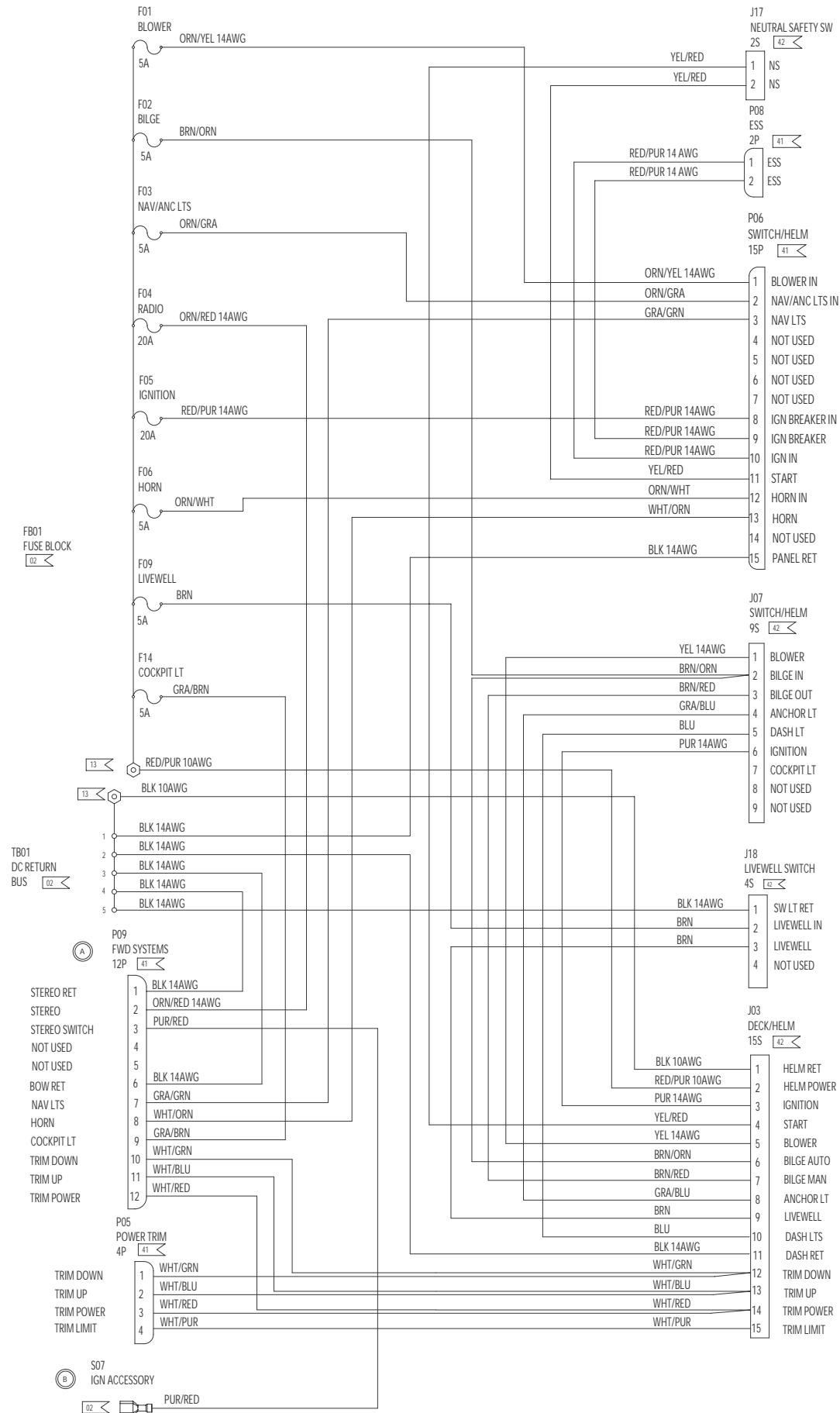

- FUSE SCHEDULE**
1. BLOWER 5A
  2. BILGE 5A
  3. NAV/ANC LTS 5A
  4. RADIO 20A
  5. IGNITION 20A
  6. HORN 5A
  9. LIVEWELL 5A
  14. COCKPIT LTS 5A

**FOUR WINNS PARTS LIST**

ITEM	PART NUMBER	QUANTITY	DESCRIPTION	FUNCTION	MANUFACTURER
	028-0177	14	RECEPT,FASTON, 250.16-14	02	AMP
	028-0195	2	TERM,RING,#10,12-10	13	AMP
	028-0390	26	PIN,UMNL,18-14	41	AMP
	028-0454	24	SOCKET,UMNL,18-14	42	AMP
	028-0455	2	SOCKET,UMNL,12-10	43	AMP
F01	028-0507	1	FUSE,ATC,5A	BLOWER	BUSS
F02	028-0507	1	FUSE,ATC,5A	BILGE	BUSS
F03	028-0507	1	FUSE,ATC,5A	NAV/ANC	BUSS
F04	028-0511	1	FUSE,ATC,20A	RADIO	BUSS
F05	028-0511	1	FUSE,ATC,20A	IGNITION	BUSS
F06	028-0507	1	FUSE,ATC,5A	HORN	BUSS
F09	028-0507	1	FUSE,ATC,5A	LIVEWELL	BUSS
F14	028-0507	1	FUSE,ATC,5A	COCKPIT LT	BUSS
FB01	028-0575	1	FUSE BLOCK,14 POS/GROUND	HELM POWER	SIERRA
P05	028-0448	1	PLUG,UMNL,4 CKT	POWER TRIM	AMP
P06	028-0452	1	PLUG,UMNL,15 CKT	SWITCH/HELM	AMP
P08	028-0447	1	PLUG,UMNL,2 CKT	ESS	AMP
P09	028-0451	1	PLUG,UMNL,12 CKT	FWD SYSTEMS	AMP
J03	028-0446	1	RECEPT,UMNL,15 CKT	DECK/HELM	AMP
J07	028-0443	1	RECEPT,UMNL,9 CKT	SWITCH/HELM	AMP
J17	028-0441	1	RECEPT,UMNL,2 CKT	NEUTRAL SAFETY SW	AMP
J18	028-0442	1	RECEPT,UMNL,4 CKT	LIVEWELL SWITCH	AMP
TB01	028-0186	REF	RETURN BUSS	DC RETURN	SIERRA
S07	-	REF	IGNITION ACCESSORY	IGNITION SWITCH	-

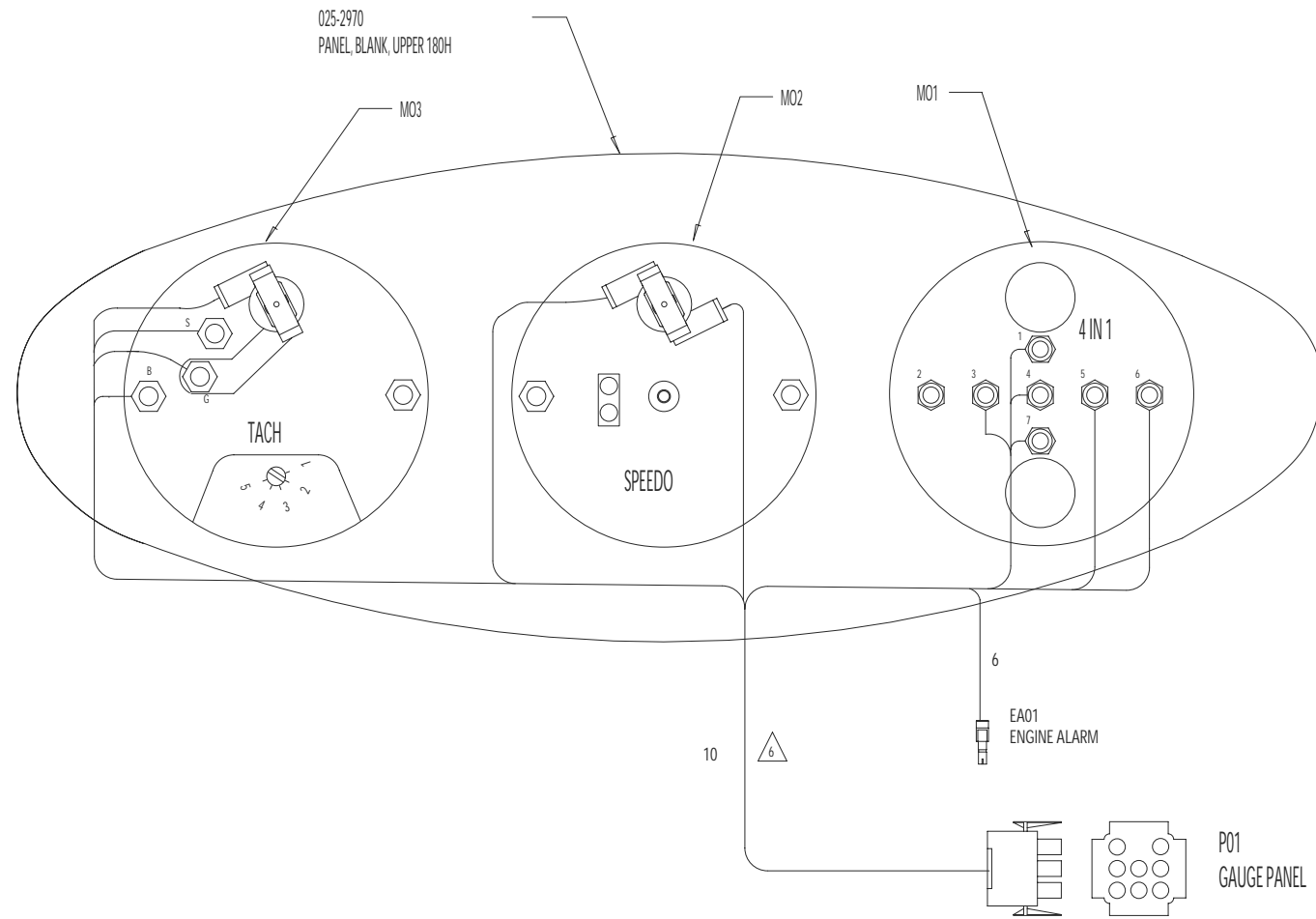

DASH LTS  
WATER TEMP.  
RETURN  
OIL PRESS.  
FUEL LEVEL  
INST.PWR  
TACH  
ENGINE ALARM  
NOT USED

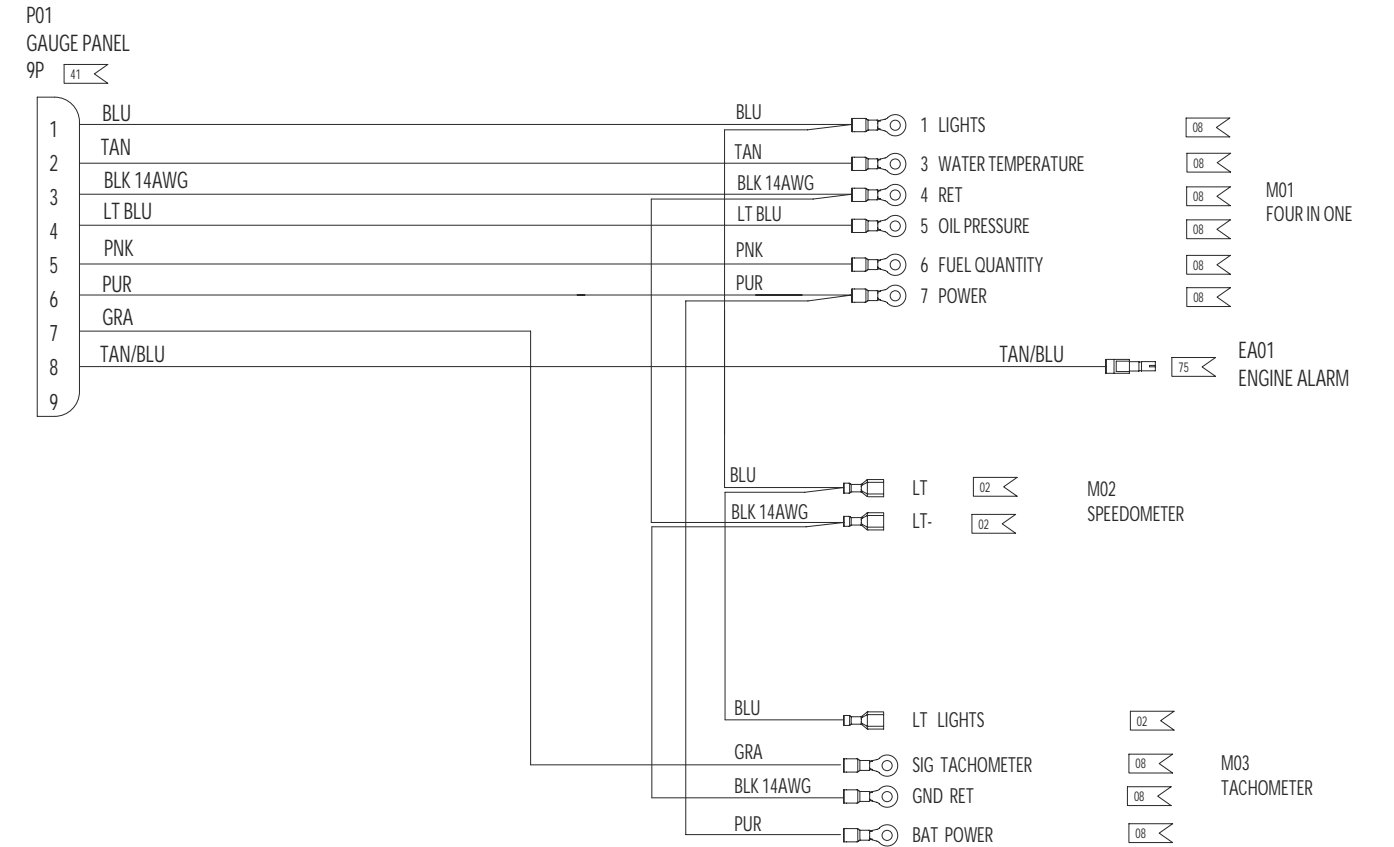

### FOUR WINNS PARTS LIST

ITEM	PART NUMBER	QUANTITY	DESCRIPTION	FUNCTION	MANUFACTURER
-	028-0390	8	PIN,UMNL,18-14	41	AMP
-	028-0189	9	TERM,RING,PG #8,16-14	08	AMP
-	028-0177	3	RECEPT,FASTON,,250,16-14	02	AMP
-	028-1823	1	TERM,BULLET,FEMALE,INS,,156,16-14	75	MOLEX
P01	028-0449	1	PLUG,UMNL,9 CKT	-	AMP
MO1	024-0524	1	GAUGE,4 IN 1, FARIA#GF0223	-	FARIA
MO2	024-0523	1	GAUGE,SPEED 65MPH FARIA#SE9972	-	FARIA
MO3	024-0526	1	GAUGE,TACH 6000 W/HOUR, FARIA#TCH239	-	FARIA
PANEL	025-2970	1	PANEL, BLANK, UPPER 180H	-	-



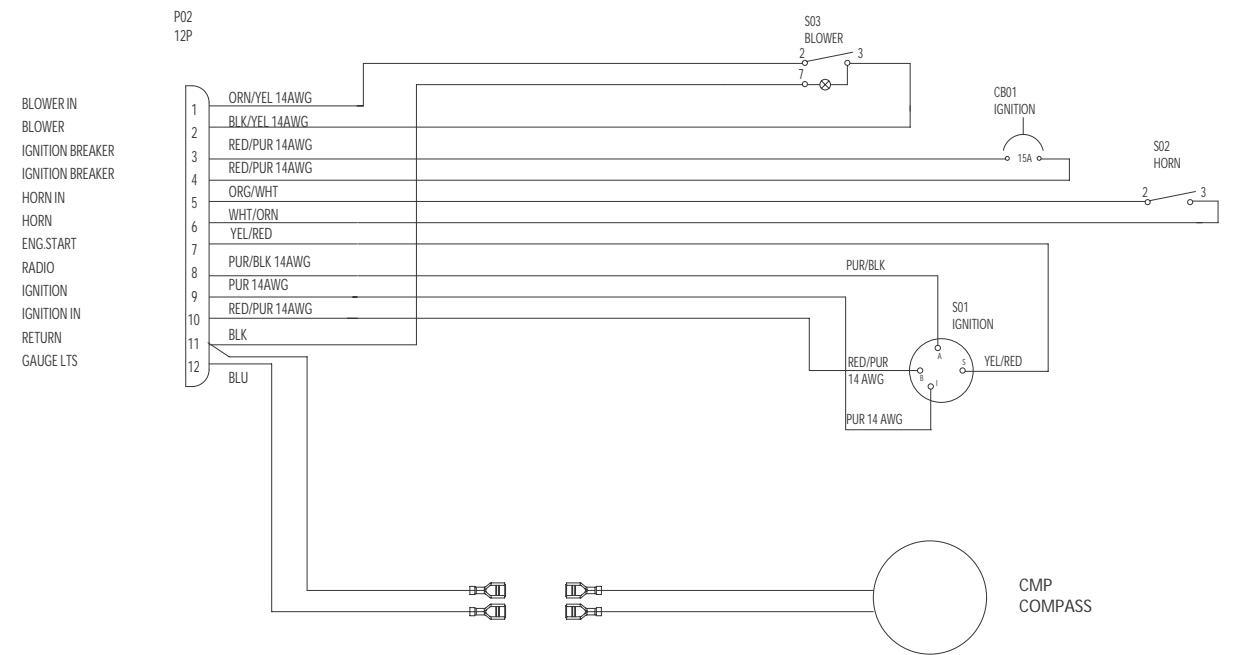
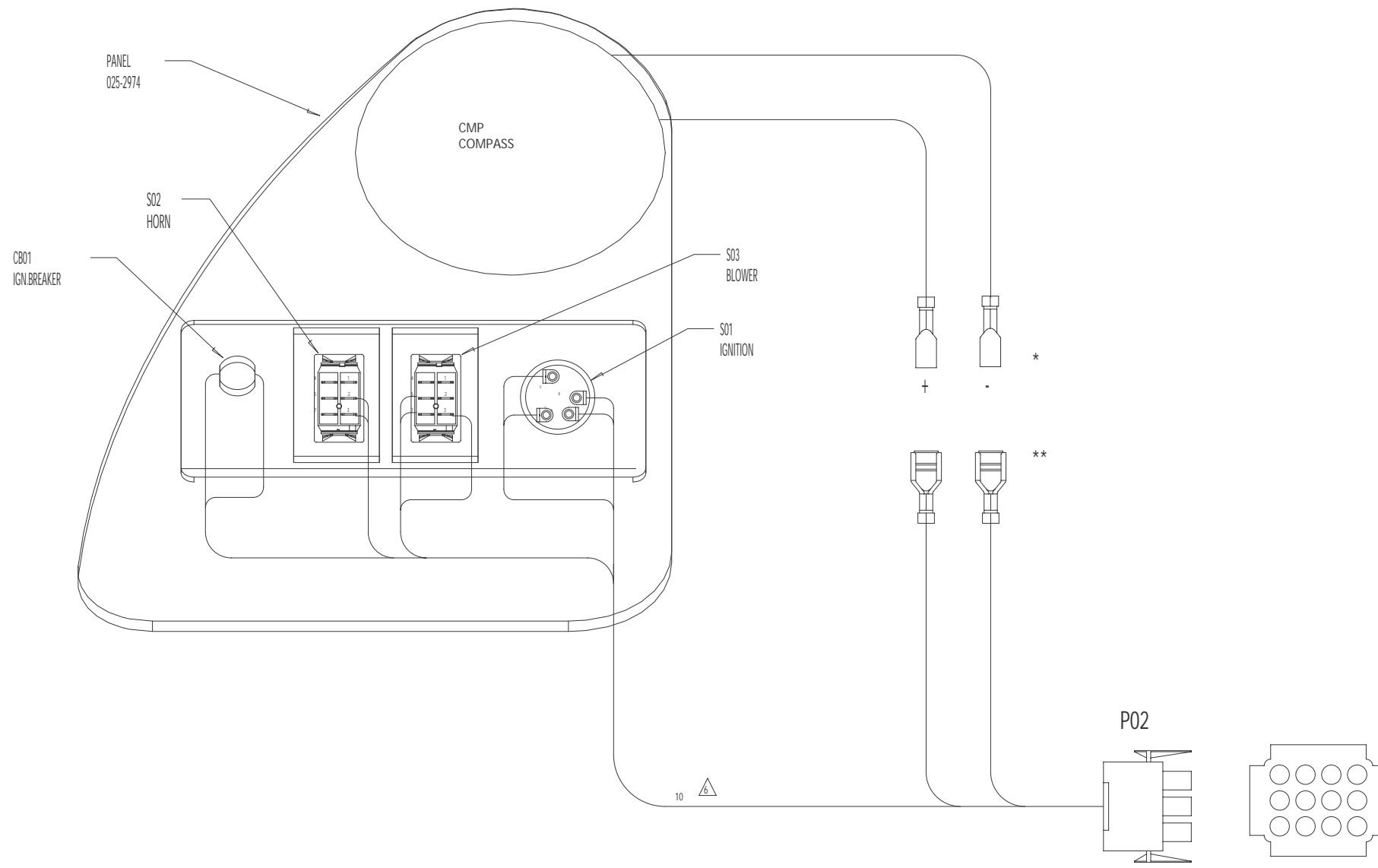

**FOUR WINNS PARTS LIST**

ITEM	PART NUMBER	QUANTITY	DESCRIPTION	MANUFACTURER	MANUF.PART #
CMP	065-1369	1	COMPASS	RITCHIE	X-15VBU
PANEL	025-2974	1	PANEL,BLANK,IGN./SW,FLOR,BURL	180HLS 03	
S01	028-1286	1	SWITCH,IGNITION,W/ ACC.	SIERRA	MP39802
S02	028-0456	1	SWITCH,SPST,MOM,CONT.III	CARLSW	
P02	028-0451	1	PLUG,UMNL,12 CKTS	AMP	1-480708-0
-	028-0390	12	PIN,UMNL,18-14	AMP	350918-3
-	028-0178	7	RECEPT,FASTON,U.F.,250,16-14	AMP	3-350820-2
CB01	028-0467	1	BREAKER,15A,THERMAL	MP	
S03	028-0457	1	SWITCH,SPST,CONT.III	CARLSW	V1D1B608-CM200
*	--	2	FASTON, TAB .25	MOLEX	3-520106-2
**	--	2	FASTON, RECEPT .25	MOLEX	19003-0042

**180 HORIZON I/O  
IGNITION SWITCH  
PANEL ASSEMBLY**

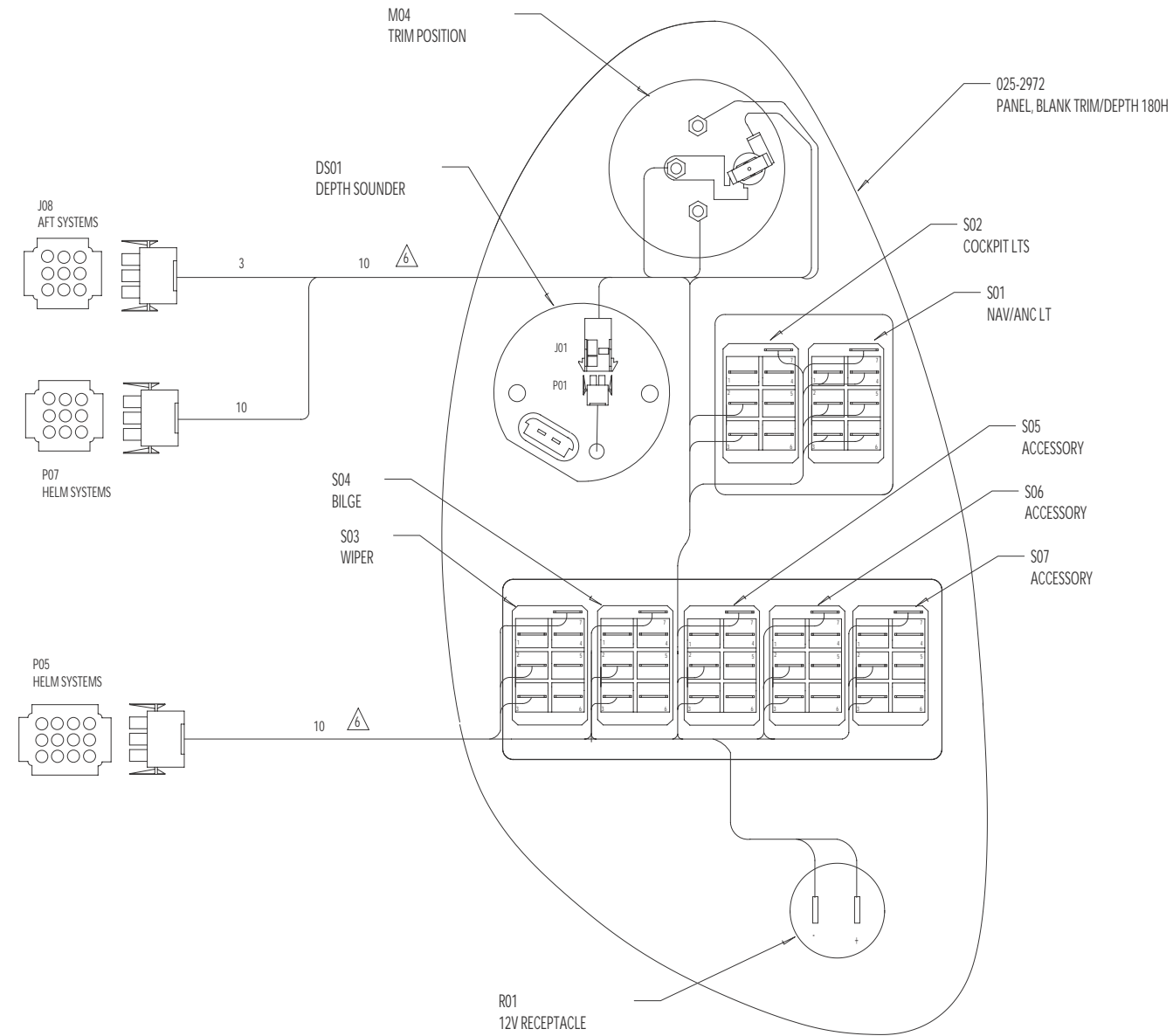

**FOUR WINNS PARTS LIST**

ITEM	PART NUMBER	QUANTITY	DESCRIPTION	FUNCTION	MANUFACTURER
-	028-0177	1	RECEPT,FASTON,.250,16-14	02	AMP
-	028-0189	1	TERM,RING,PG,#8,16-14	08	AMP
-	028-0390	1	PIN,UNML,18-14	41	AMP
-	025-2972	1	PANEL,BLANK,TRIM/DEPTH BURL 180H	-	-
J01	028-0441	1	RECEPT,UMNL,2 CKT	DEPTH	AMP
P01	028-0447	1	PLUG,UMNL,2 CKT	DEPTH	AMP
P05	028-0449	1	PLUG,UMNL,9 CKT	HELM SYSTEMS	AMP
P07	028-0449	1	PLUG,UMNL,9 CKT	HELM SYSTEMS	AMP
P08	028-0451	1	PLUG,UMNL,12 CKT	AFT SYSTEMS	AMP
R01	028-1100	1	12V DC RECEPTACLE	DC PLUG	AFI
M01	024-0529	1	GAUGE,TRIM,FARIA#GP7766	TRIM	FARIA
M02	028-1748	1	GAUGE,DEPTH,FARIA#DS0109	DEPTH	FARIA
S01	028-0504	1	SWITCH,DPDT,CONT.III	NAV/ANC LT	CARLING SW
S02	028-0457	1	SWITCH,SPST,CONT.III	COCKPIT LTS	CARLING SW
S03	028-0457	1	SWITCH,SPST,CONT.III	WIPER	CARLING SW
S04	028-0457	1	SWITCH,SPST,CONT.III	BILGE	CARLING SW
S05	028-0457	1	SWITCH,SPST,CONT.III	ACC	CARLING SW
S06	028-0457	1	SWITCH,SPST,CONT.III	ACC	CARLING SW
S07	028-0457	1	SWITCH,SPST,CONT.III	ACC	CARLING SW

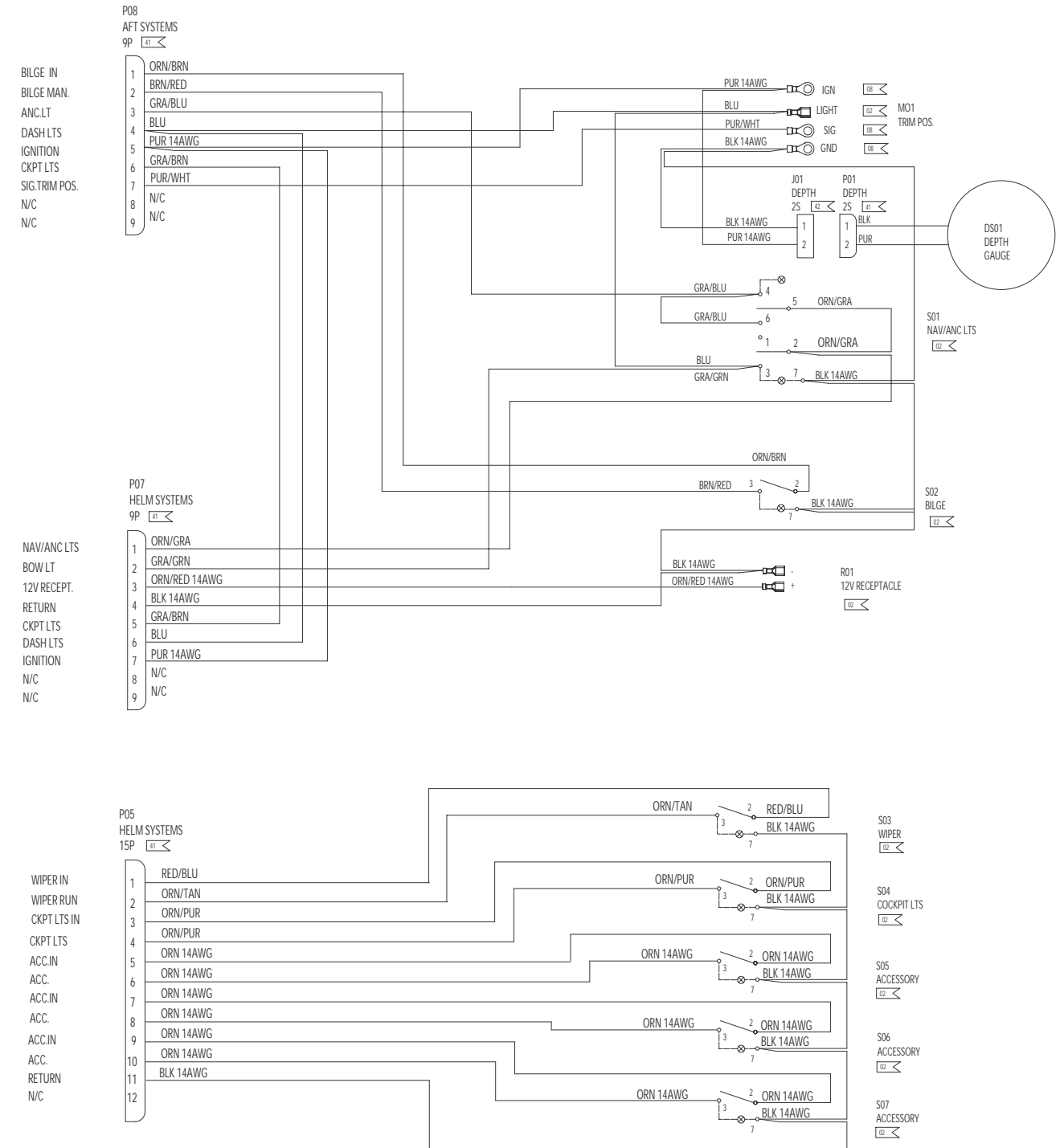

**180 HORIZON I/O TRIM PANEL ASSEMBLY**

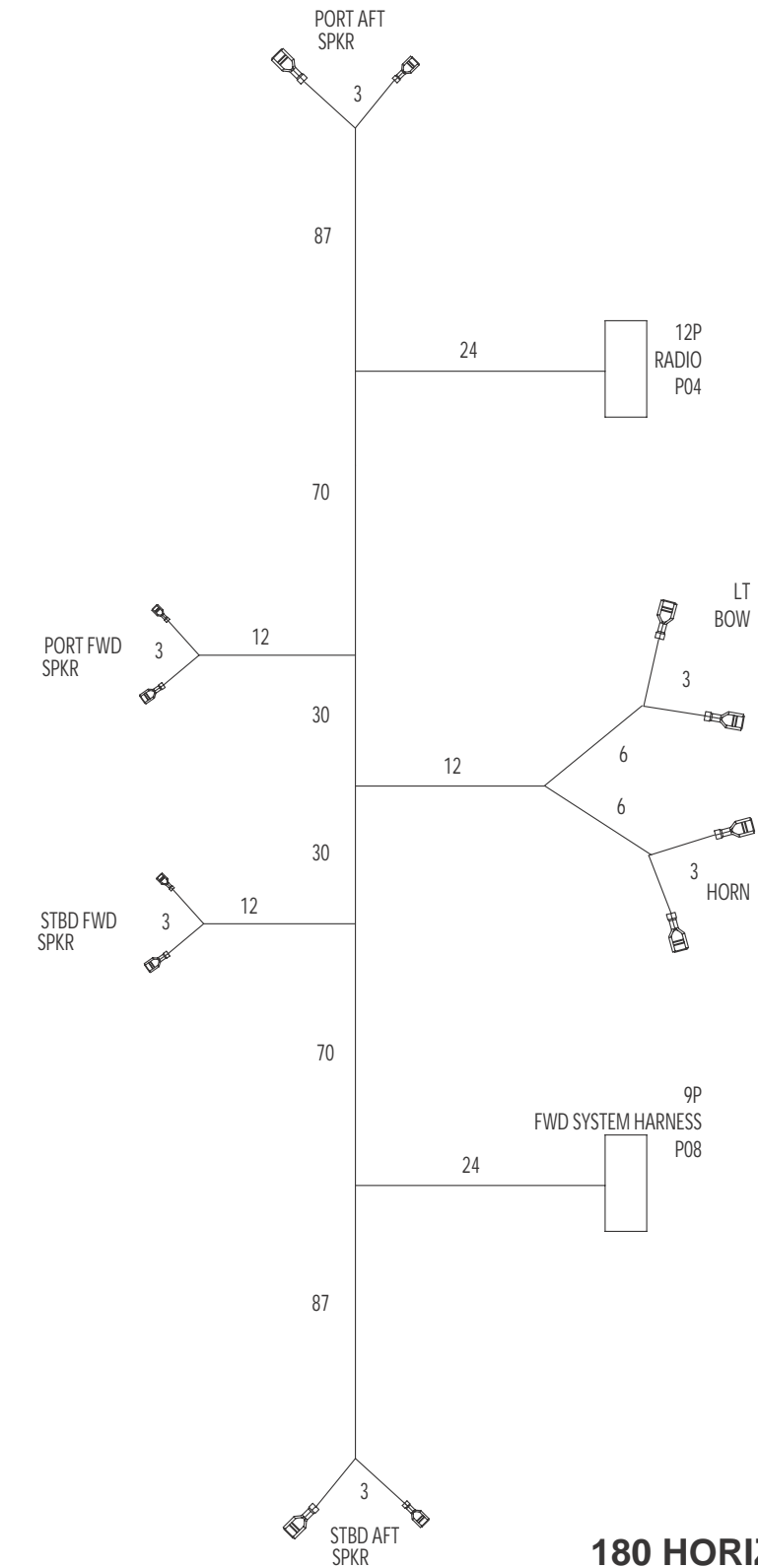
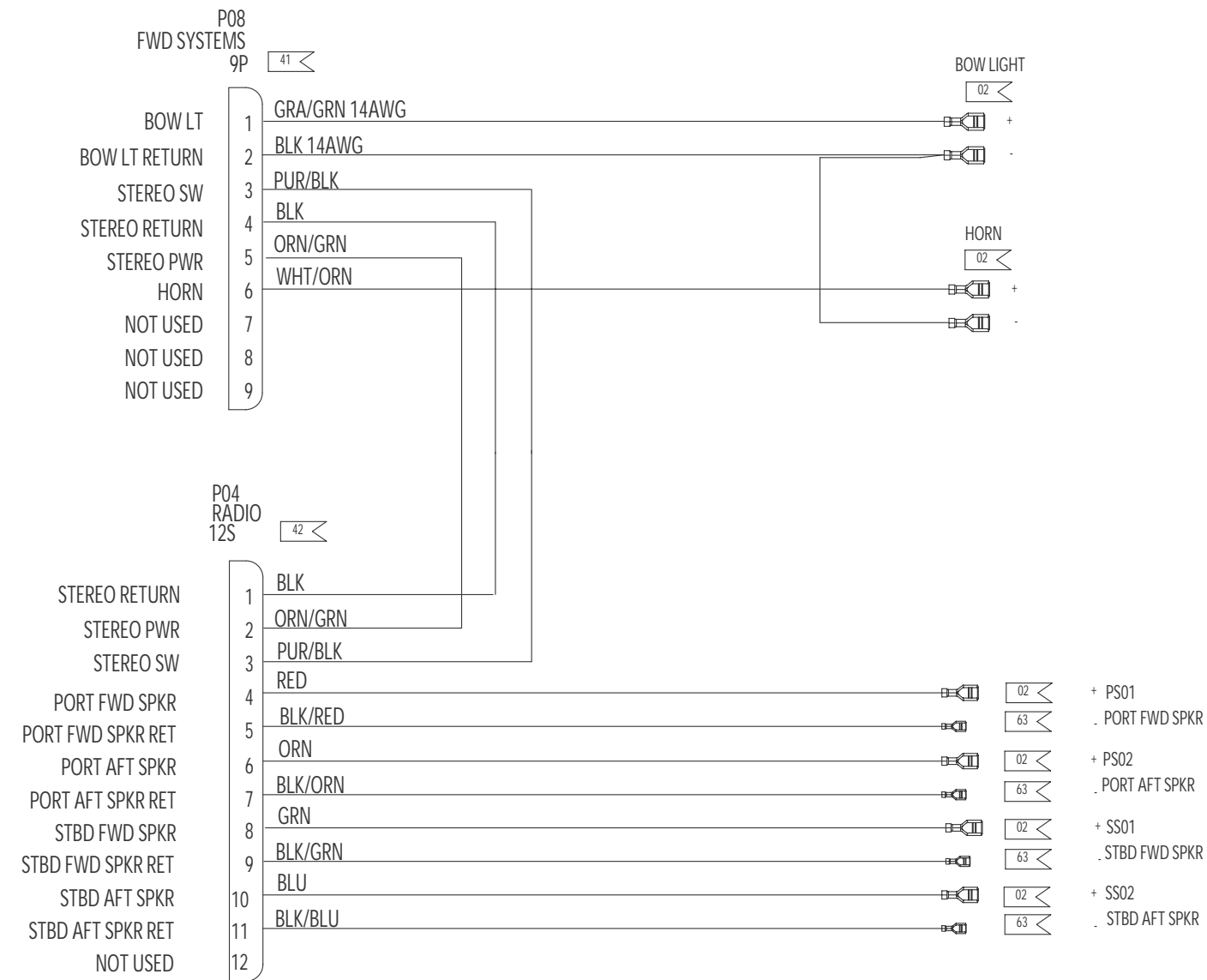

## FOUR WINNS PARTS LIST

ITEM	PART NUMBER	QUANTITY	DESCRIPTION	FUNCTION	MANUFACTURER
P04	028-0451	1	PLUG,UMNL,12 CKT	RADIO	AMP
P08	028-0449	1	PLUG,UMNL,9 CKT	FWD SYSTEMS	AMP
-	028-1288	4	RECEPT,FASTON,,205,18-14	63	AMP
-	028-0454	11	SOCKET,UMNL,18-14	42	AMP
-	028-0390	6	PIN,UMNL,18-14	41	AMP
-	028-0177	8	RECEPT,FASTON,,250,16-14	02	AMP

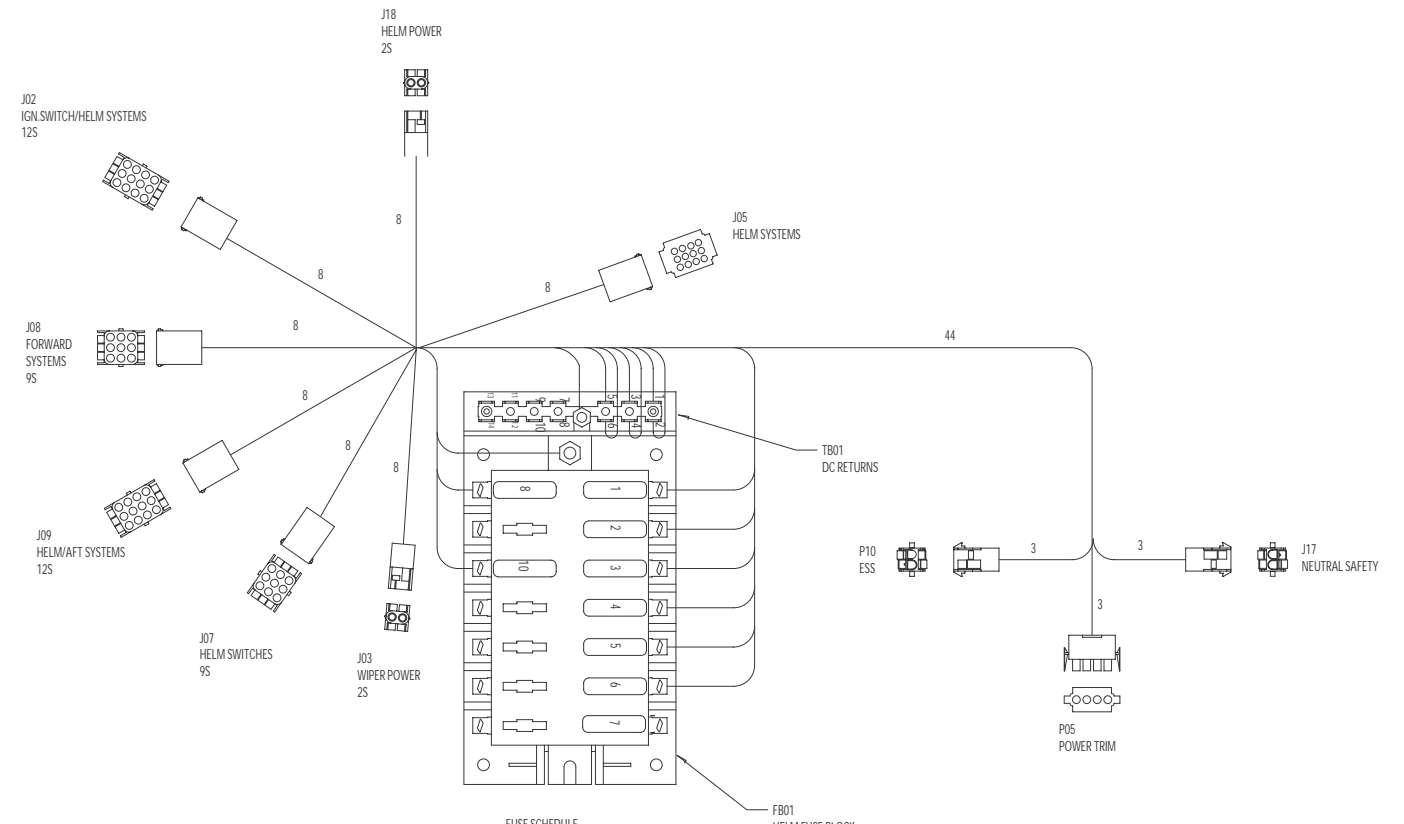
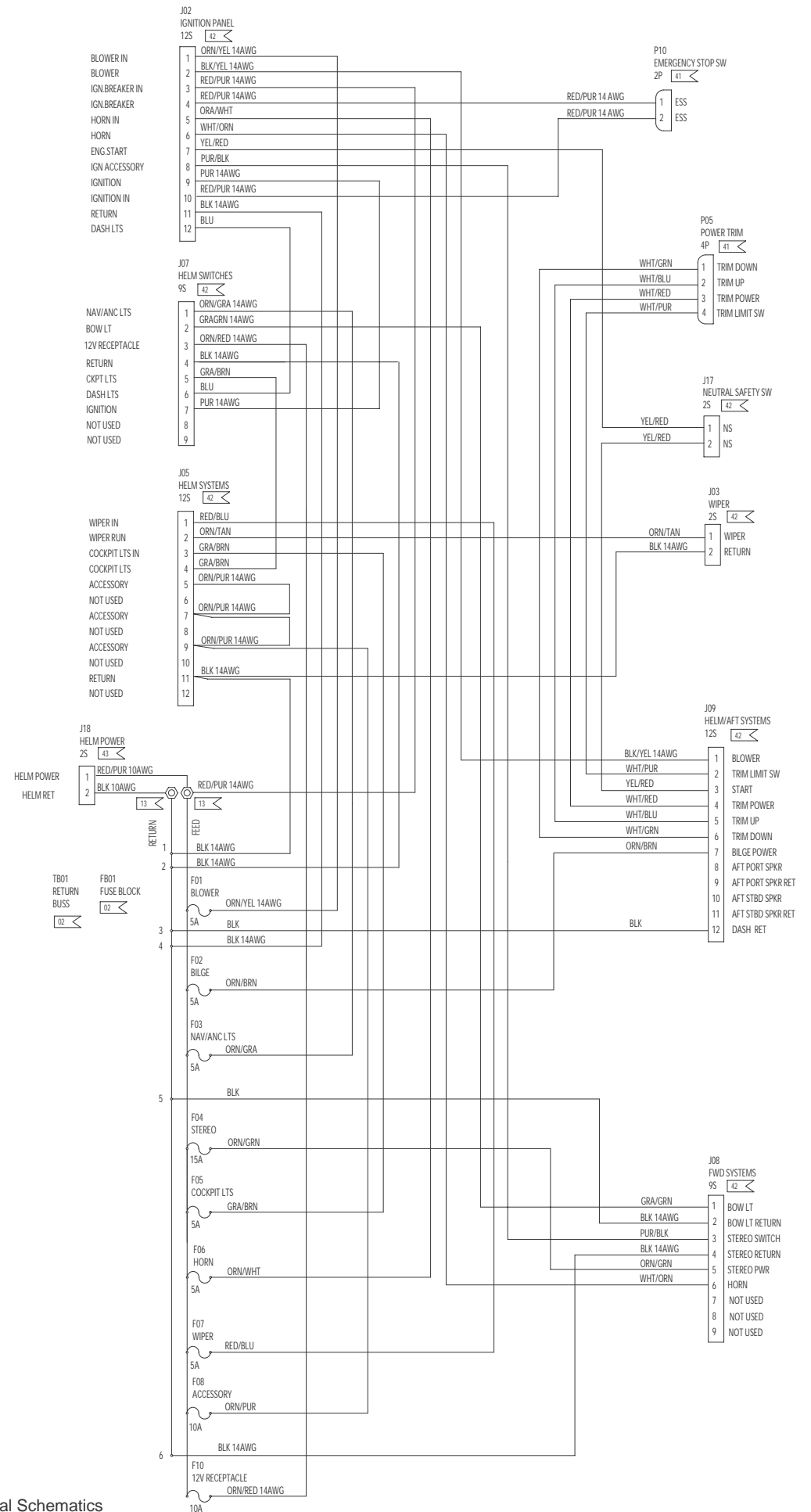

**FOUR WINNS PARTS LIST**

ITEM	PART NUMBER	QUANTITY	DESCRIPTION	FUNCTION	MANUFACTURER
-	028-0177	15	TERM,FASTON,.250,18-14	02	AMP
-	028-0195	2	TERM,RING,#10,12-10	13	AMP
-	028-0390	6	PIN,UMNL,18-14	41	AMP
-	028-0454	45	SOCKET,UMNL,18-14	42	AMP
-	028-0455	2	SOCKET,UMNL,12-10	43	AMP
FB01	028-0505	1	FUSE BLOCK,14 POS W/GND	HELM FUSE BLOCK	SIERRA
F01	028-0507	1	FUSE,ATC,5A	BLOWER BUSS	BUSS
F02	028-0507	1	FUSE,ATC,5A	BILGE	BUSS
F03	028-0507	1	FUSE,ATC,5A	NAV/ANC LTS	BUSS
F04	028-0510	1	FUSE,ATC,15A	STEREO PWR	BUSS
F05	028-0507	1	FUSE,ATC,5A	COCKPIT LTS	BUSS
F06	028-0507	1	FUSE,ATC,5A	HORN	BUSS
F07	028-0507	1	FUSE,ATC,5A	WIPER	BUSS
F08	028-0509	1	FUSE,ATC,10A	ACCESSORY	BUSS
F10	028-0509	1	FUSE,ATC,10A	12V RECEPTACLE	BUSS
J08	028-0443	1	RECEPT,UMNL,9 CKT	FWD SYSTEMS	AMP
J02	028-0445	1	RECEPT,UMNL,12 CKT	IGNITION PANEL	AMP
J18	028-0441	1	RECEPT,UMNL,2 CKT	HELM POWER	AMP
P05	028-0448	1	PLUG,UMNL,4 CKT	POWER TRIM	AMP
P10	028-0447	1	PLUG,UMNL,2 CKT	ESS	AMP
J17	028-0441	1	RECEPT,UMNL,2 CKT	NEUTRAL SAFETY	AMP
J03	028-0441	1	RECEPT,UMNL,2 CKT	WIPER	AMP
J05	028-0445	1	RECEPT,UMNL,12 CKT	HELM SYSTEMS	AMP
J07	028-0443	1	RECEPT,UMNL,9 CKT	HELM SWITCHES	AMP
J09	028-0445	1	RECEPT,UMNL,12 CKT	HELM/AFT SYSTEMS	AMP
TB01	-	REF	DC RETURN BUSS	GROUND BLOCK	SIERRA

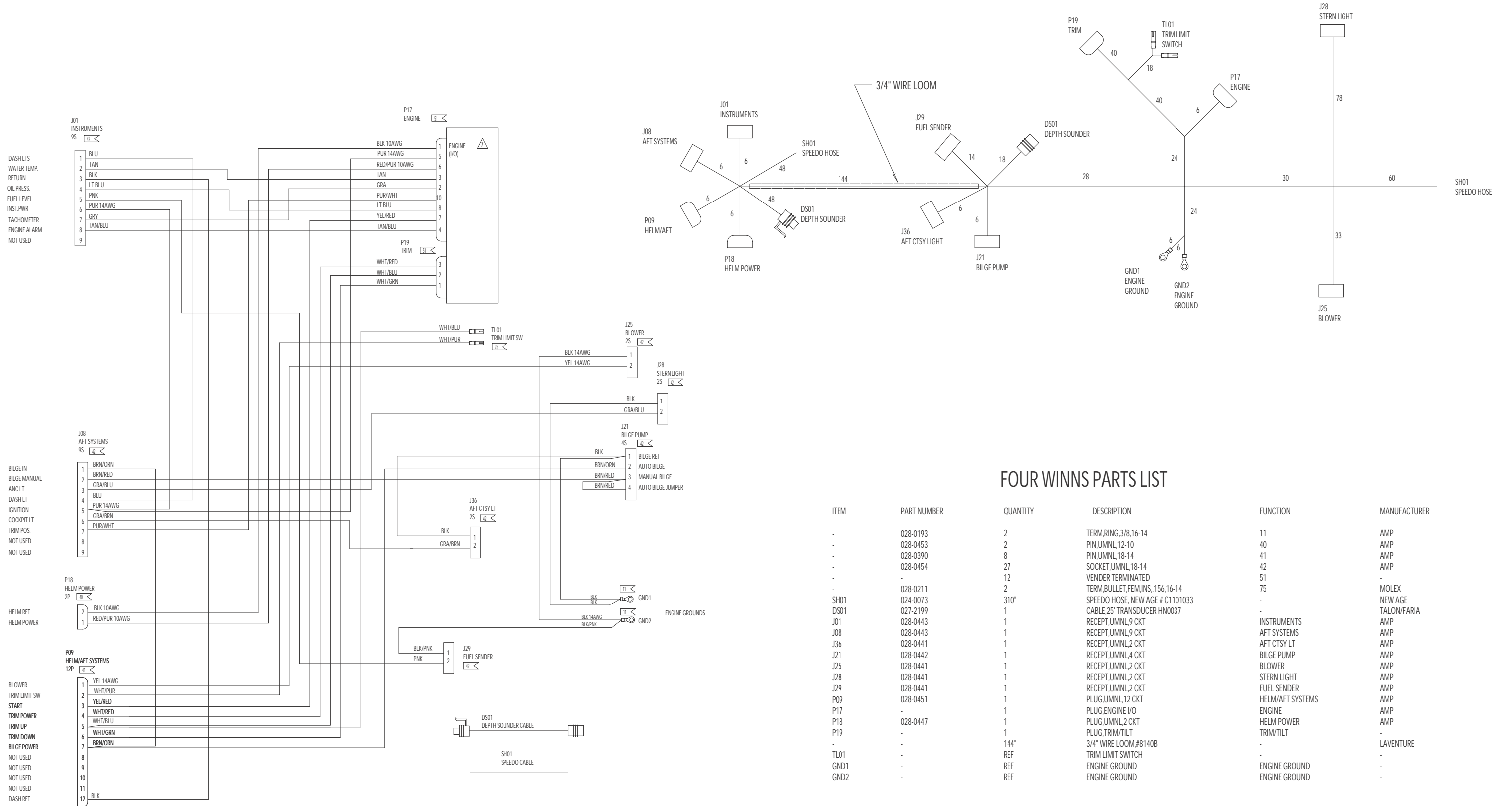

FOUR WINNS PARTS LIST

ITEM	PART NUMBER	QUANTITY	DESCRIPTION	FUNCTION	MANUFACTURER
-	028-0193	2	TERM.RING,3/8,16-14	11	AMP
-	028-0453	2	PIN,UMNL,12-10	40	AMP
-	028-0390	8	PIN,UMNL,18-14	41	AMP
-	028-0454	27	SOCKET,UMNL,18-14	42	AMP
-	-	12	VENDER TERMINATED	51	-
-	028-0211	2	TERM.BULLET,FEM,INS.,156,16-14	75	MOLEX
SH01	024-0073	310"	SPEEDO HOSE, NEW AGE # C1101033	-	NEW AGE
DS01	027-2199	1	CABLE,25' TRANSDUCER HN0037	-	TALON/FARIA
J01	028-0443	1	RECEPT,UMNL,9 CKT	INSTRUMENTS	AMP
J08	028-0443	1	RECEPT,UMNL,9 CKT	AFT SYSTEMS	AMP
J36	028-0441	1	RECEPT,UMNL,2 CKT	AFT CTSY LT	AMP
J21	028-0442	1	RECEPT,UMNL,4 CKT	BILGE PUMP	AMP
J25	028-0441	1	RECEPT,UMNL,2 CKT	BLOWER	AMP
J28	028-0441	1	RECEPT,UMNL,2 CKT	STERN LIGHT	AMP
J29	028-0441	1	RECEPT,UMNL,2 CKT	FUEL SENDER	AMP
P09	028-0451	1	PLUG,UMNL,12 CKT	HELM/AFT SYSTEMS	AMP
P17	-	1	PLUG,ENGINE I/O	ENGINE	AMP
P18	028-0447	1	PLUG,UMNL,2 CKT	HELM POWER	AMP
P19	-	1	PLUG,TRIM/TILT	TRIM/TILT	-
-	-	144"	3/4" WIRE LOOM,#8140B	-	LAVENTURE
TL01	-	REF	TRIM LIMIT SWITCH	-	-
GND1	-	REF	ENGINE GROUND	ENGINE GROUND	-
GND2	-	REF	ENGINE GROUND	ENGINE GROUND	-

180 HORIZON I/O  
AFT SYSTEMS  
HARNES ASSEMBLY

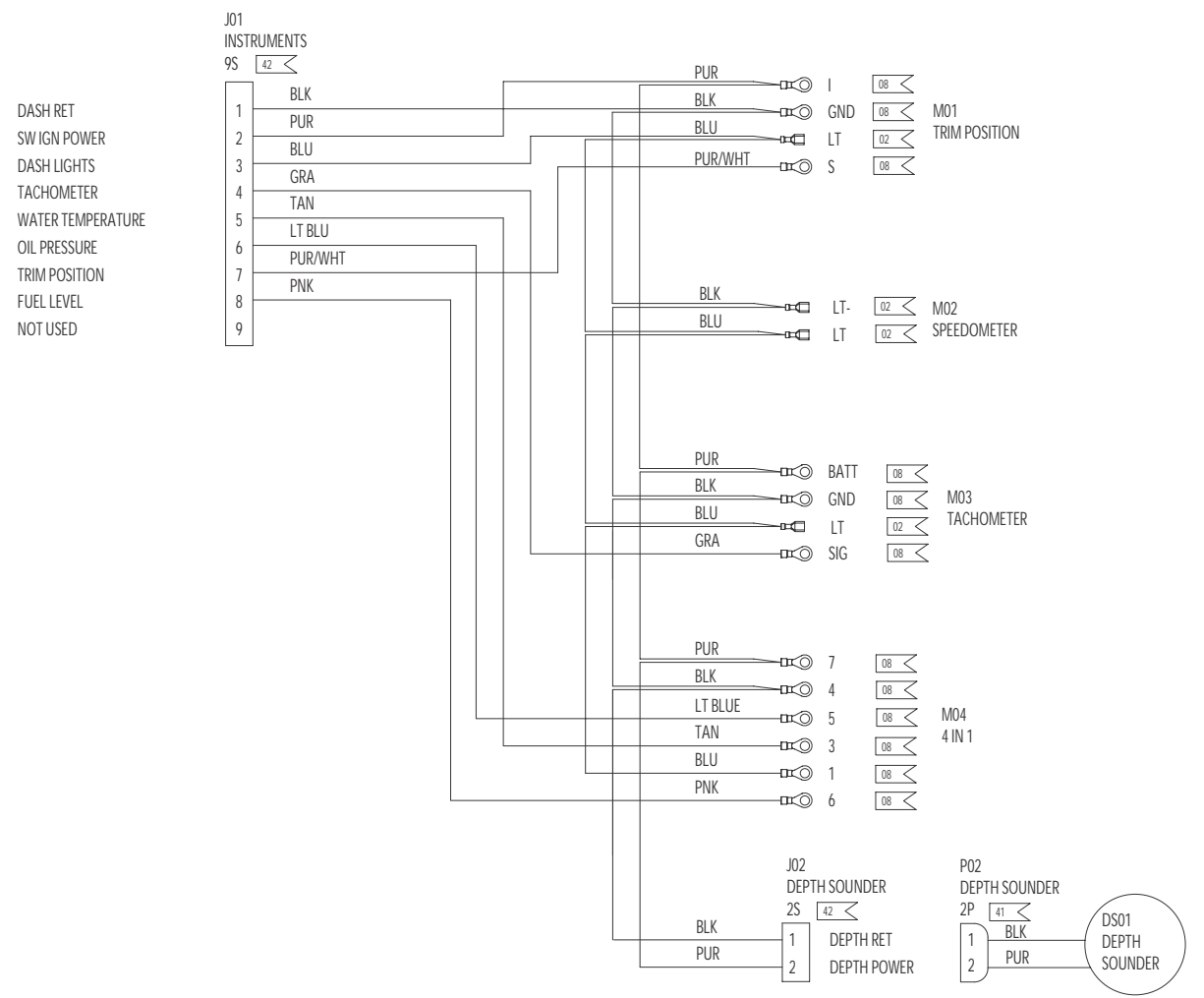
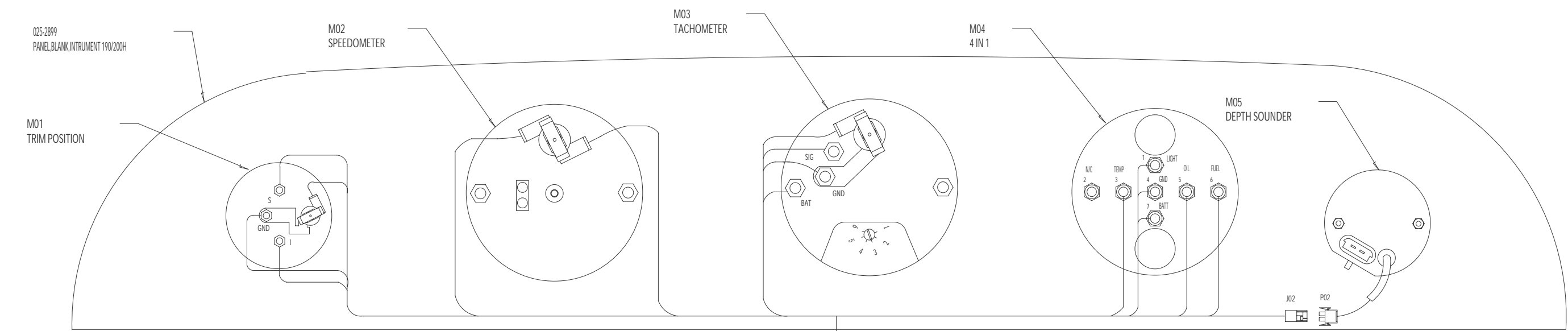

### FOUR WINNS PARTS LIST

ITEM	PART NUMBER	QUANTITY	DESCRIPTION	FUNCTION	MANUFACTURER
-	028-0177	4	RECEPTACLE,FASTON,.250,16-14	02	AMP
-	028-0189	12	TERMINAL,RING,PG,#8, 16-14	08	AMP
-	028-0390	2	PIN,UMNL,18-14	41	AMP
-	028-0454	10	SOCKET,UMNL,18-14	42	AMP
-	025-2899	1	PANEL,BLANK,INSTR, BURL 190/200H	-	-
J01	028-0443	1	RECEPT,UMNL, 9 CKT	INSTRUMENTS	AMP
J02	028-0441	1	RECEPT,UMNL, 2 CKT	DEPTH	AMP
P02	028-0447	1	PLUG, UMNL, 2 CKT	DEPTH	AMP
M01	024-0529	1	GAUGE,TRIM,FARIA#GP7766	-	FARIA
M02	024-0523	1	GAUGE,SPEED 65MPH,FARIA#SE9972	-	FARIA
M03	024-0526	1	GAUGE,TACH 6000 W/HOUR,FARIA#TCH239	-	FARIA
M04	024-0524	1	GAUGE,4IN1 W/FUEL,FARIA#GF0223	-	FARIA
M05	028-1748	1	DEPTH SOUNDER,FARIA#DS0109	-	FARIA

### 190-200 HORIZON INSTRUMENTATION PANEL ASSEMBLY



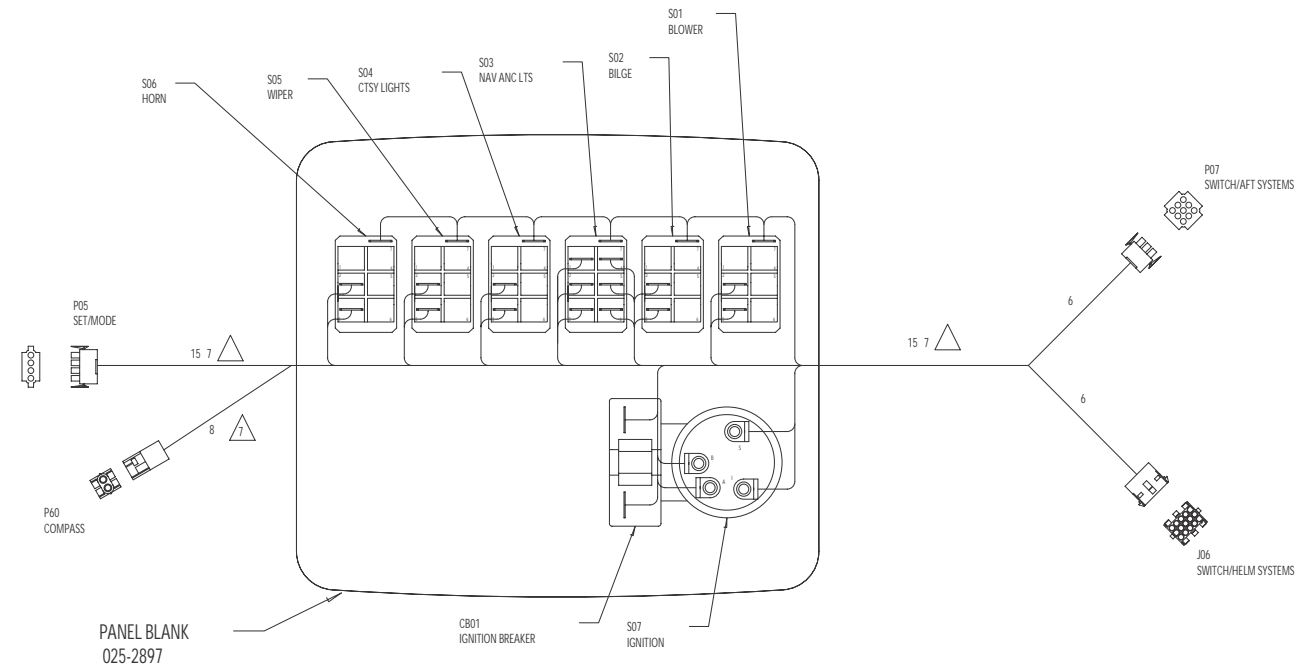

FOUR WINNS WIRE LIST

COLOR	GA	FIRST	PIN	TERM	NOTE	SECOND	PIN	TERM	NOTE	FUNCTION
ORN/YEL	16	J06	1	42		S01	2	02		BLOWER IN
ORN/GRA	16	J06	2	42		S03	2	02	SC	NAV/ANC IN
GRA/GRN	16	J06	3	42		S03	3	02	SD	BOW LT
ORN/PUR	16	J06	4	42		S04	2	02		COCKPIT LT IN
GRA/BRN	16	J06	5	42	SA	S04	3	02		FWD COCKPIT LT
GRA/BRN	16	J06	5	42	SA	P07	7	41		COCKPIT LT
ORN/TAN	16	J06	6	42		S05	2	02		WIPER IN
ORN	16	J06	7	42		P05	3	41		ACCESSORY IN
RED/PUR	14	J06	8	42		CB01	LINE	02		IGNITION BREAKER IN
RED/PUR	14	J06	9	42		CB01	LOAD	02	SK	IGNITION BREAKER
RED/PUR	14	J06	10	42		S07	8	02		IGNITION IN
YEL/RED	16	J06	11	42		S07	5	02		START
ORN/WHT	16	J06	12	42		S06	2	02		HORN IN
WHT/ORN	16	J06	13	42		S06	3	02		HORN
ORN/RED	14	J06	14	42		P05	2	41		12V RECEPTACLE
BLK	14	J06	15	42	SB	P05	1	41	SN	12V RECEPTACLE RET
BLK	16	J06	15	42	SB	S01	7	02	SE	SWITCH LT RET
YEL	16	P07	1	41		S01	3	02		BLOWER
BRN/ORN	16	P07	2	41		S02	2	02		BILGE IN
BRN/RED	16	P07	3	41		S02	3	02		BILGE OUT
GRA/BLU	16	P07	4	41		S03	4	02	SJ	ANC LT
BLU	16	P07	5	41	SM	S03	3	02	SD	DASH LT
BLU	16	P07	5	41	SM	J60	1	42		COMPASS LT
BLK	14	P05	1	41	SN	J60	2	42		COMPASS LT RET
PUR	14	P07	6	41		S07	1	02	SL	IGNITION
BLK	16	S01	7	02	SE	S02	7	02	SF	SWITCH LT RET
BLK	16	S02	7	02	SF	S03	7	02	SG	SWITCH LT RET
BLK	16	S03	7	02	SG	S04	7	02	SH	SWITCH LT RET
BLK	16	S04	7	02	SH	S05	7	02		SWITCH LT RET
ORN/GRA	16	S03	2	02	SC	S03	5	02		NAV/ANC LT JUMPER
GRA/BLU	16	S03	4	02	SJ	S03	6	02		ANC LT JUMPER

FOUR WINNS PARTS LIST

ITEM	PART NUMBER	QUANTITY	DESCRIPTION	FUNCTION	MANUFACTURER
	028-0177	26	RECEPT,FASTON,250,18-14	02	AMP
	028-0390	10	PIN,UMNL,18-14	41	AMP
	028-0454	17	SOCKET,UMNL,18-14	42	AMP
	028-0519	2	SWITCH,BLANK,CONT III		CARL SW
	025-2897	1	PANEL,BLANK,190/200H,IGN/SWITCH		
CB01	028-0467	1	BREAKER,15A,THERMAL	IGNITION	MP
J06	028-0446	1	RECEPT,UMNL,15 CKT	SWITCH/HELM	AMP
J60	028-0441	1	RECEPT,UMNL,2 CKT	COMPASS	AMP
P05	028-0448	1	PLUG,UMNL,4 CKT	ACCESSORY	AMP
P07	028-0449	1	SWITCH,SPST,CONT III	SWITCH/HAFT	AMP
S01	028-0457	1	SWITCH,SPST,CONT III	BLOWER	CARL SW
S02	028-0457	1	SWITCH,SPST,CONT III	BILGE	CARL SW
S03	028-0504	1	SWITCH,DPDT,CONT III	NAV/ANC	CARL SW
S04	028-0457	1	SWITCH,SPST,CONT III	CTSY	CARL SW
S05	028-0457	REF	SWITCH,SPST,CONT III	WIPER	CARL SW
S06	028-0456	1	SWITCH,SPST,MON,UMNL,LIT,CONT III	HORN	CARL SW
S07	028-1286	1	SWITCH,IGNITION W/ACCESSORY 39802	IGNITION	SIERRA

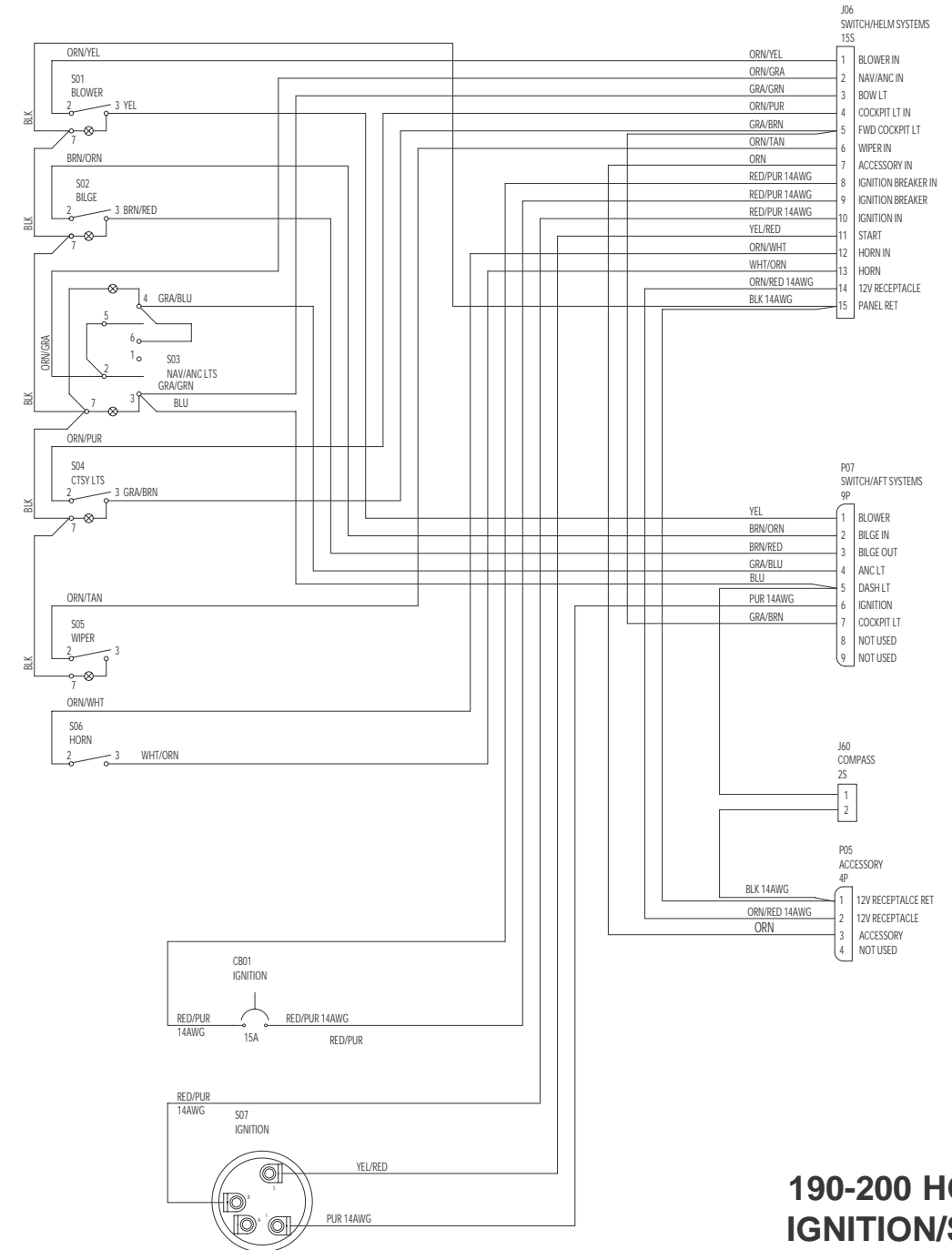

190-200 HORIZON  
IGNITION/SWITCH  
PANEL ASSEMBLY

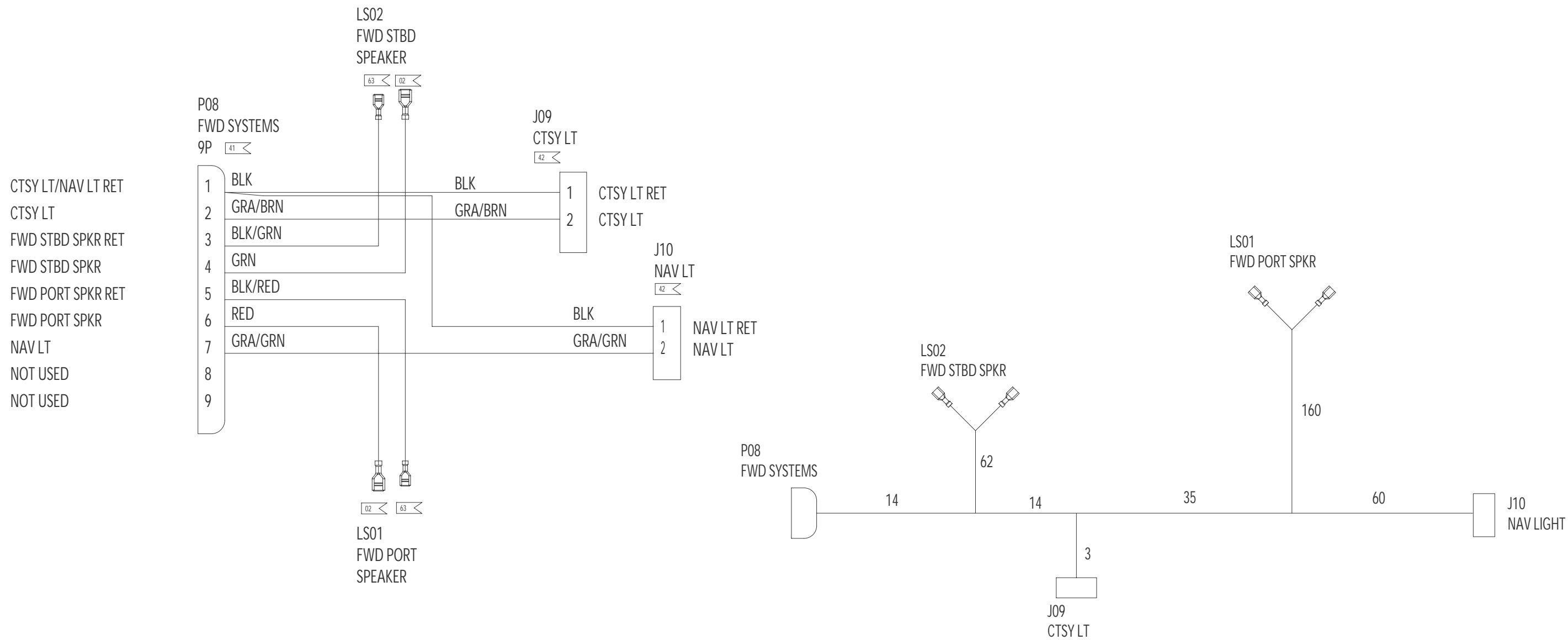

### FOUR WINNS PARTS LIST

ITEM	PART NUMBER	QUANTITY	DESCRIPTION	FUNCTION	MANUFACTURER
	028-0177	2	RECEPT.FASTON,.250,16-14	02	AMP
	028-0390	7	PIN,UMNL,18-14	41	AMP
	028-0454	4	SOCKET,UMNL,18-14	42	AMP
	028-1288	2	RECEPT,FASTON,.205,18-14	63	AMP
J09	028-0441	1	RECEPT,UMNL,2 CKT	CTSY LIGHTS	AMP
J10	028-0441	1	RECEPT,UMNL,2 CKT	NAV LIGHT	AMP
LS01		REF	SPEAKER	FWD PORT SPKR	
LS02		REF	SPEAKER	FWD STBD SPKR	
P08	028-0449	1	PLUG,UMNL,9 CKT	FWD SYSTEMS	AMP

**190-200 HORIZON  
FORWARD SYSTEMS  
HARNESS ASSEMBLY**

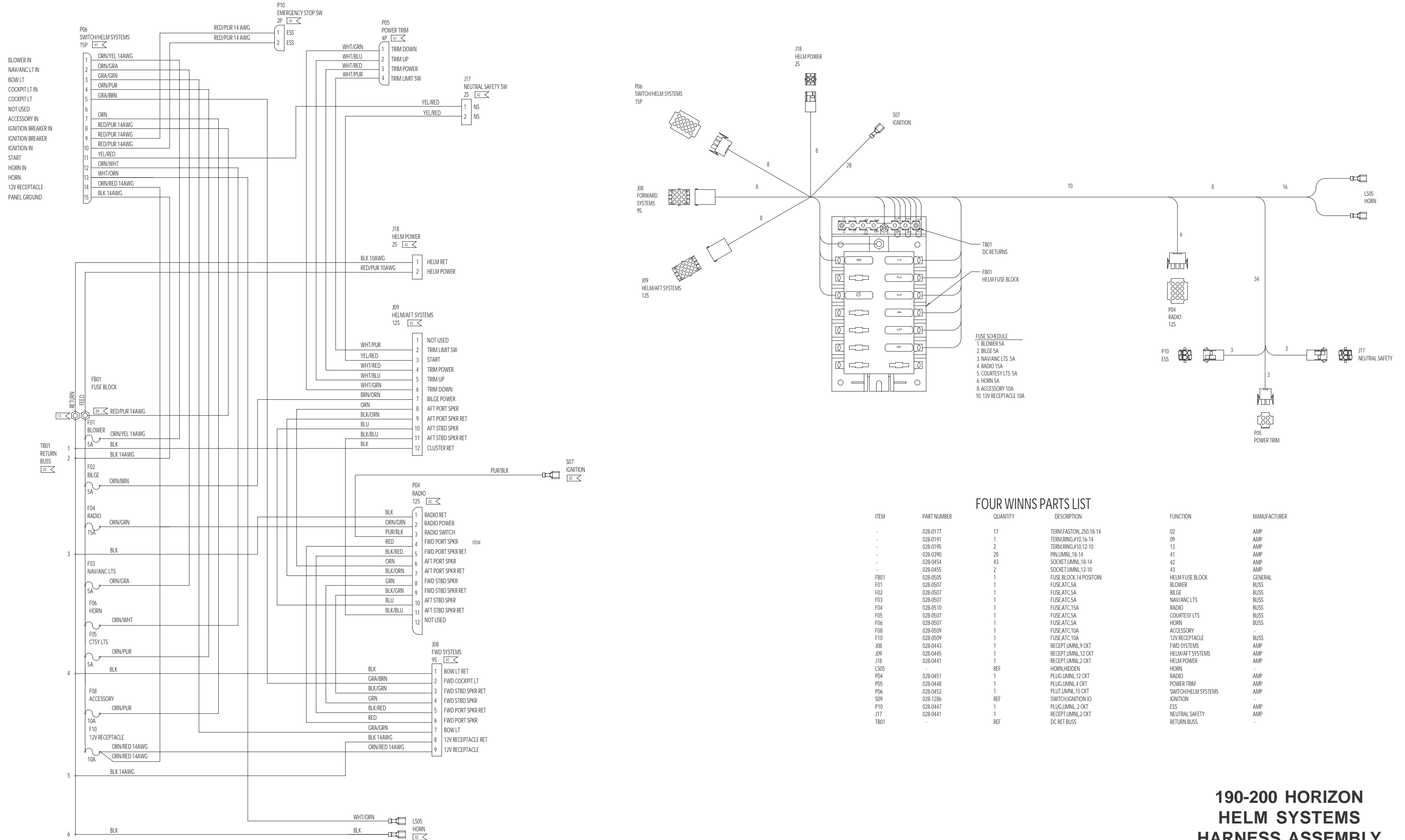

**190-200 HORIZON  
HELM SYSTEMS  
HARNES ASSEMBLY**

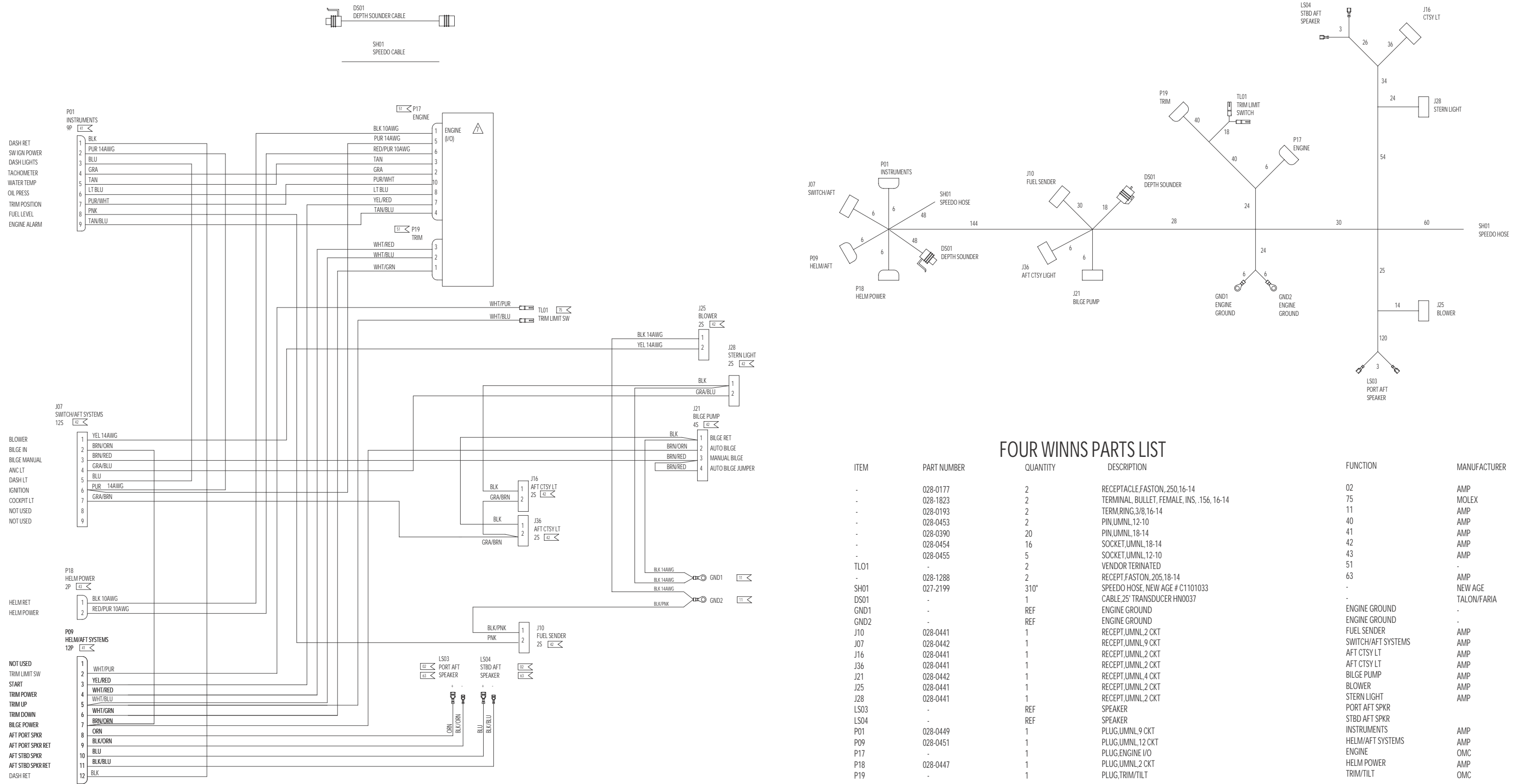

FOUR WINNS PARTS LIST

ITEM	PART NUMBER	QUANTITY	DESCRIPTION	FUNCTION	MANUFACTURER
-	028-0177	2	RECEPTACLE,FASTON ,250,16-14	02	AMP
-	028-1823	2	TERMINAL, BULLET, FEMALE, INS. ,156, 16-14	75	MOLEX
-	028-0193	2	TERM.RING,3/8,16-14	11	AMP
-	028-0453	2	PIN,UMNL,12-10	40	AMP
-	028-0390	20	PIN,UMNL,18-14	41	AMP
-	028-0454	16	SOCKET,UMNL,18-14	42	AMP
-	028-0455	5	SOCKET,UMNL,12-10	43	AMP
-	-	2	VENDOR TERMINATED	51	-
-	028-1288	2	RECEPT,FASTON ,205,18-14	63	AMP
SH01	027-2199	310*	SPEEDO HOSE, NEW AGE # C1101033	-	NEW AGE
DS01	-	1	CABLE,25' TRANSDUCER HNO037	-	TALON/FARIA
GND1	-	REF	ENGINE GROUND	ENGINE GROUND	-
GND2	-	REF	ENGINE GROUND	ENGINE GROUND	-
J10	028-0441	1	RECEPT,UMNL,2 CKT	FUEL SENDER	AMP
J07	028-0442	1	RECEPT,UMNL,9 CKT	SWITCH/AFT SYSTEMS	AMP
J16	028-0441	1	RECEPT,UMNL,2 CKT	AFT CTSY LT	AMP
J36	028-0441	1	RECEPT,UMNL,2 CKT	AFT CTSY LT	AMP
J21	028-0442	1	RECEPT,UMNL,4 CKT	BILGE PUMP	AMP
J25	028-0441	1	RECEPT,UMNL,2 CKT	BLOWER	AMP
J28	028-0441	1	RECEPT,UMNL,2 CKT	STERN LIGHT	AMP
LS03	-	REF	SPEAKER	PORT AFT SPKR	-
LS04	-	REF	SPEAKER	STBD AFT SPKR	-
P01	028-0449	1	PLUG,UMNL,9 CKT	INSTRUMENTS	AMP
P09	028-0451	1	PLUG,UMNL,12 CKT	HELM/AFT SYSTEMS	AMP
P17	-	1	PLUG,ENGINE I/O	ENGINE	OMC
P18	028-0447	1	PLUG,UMNL,2 CKT	HELM POWER	AMP
P19	-	1	PLUG,TRIM/TILT	TRIM/TILT	OMC

190-200 HORIZON  
AFT SYSTEMS  
HARNES ASSEMBLY

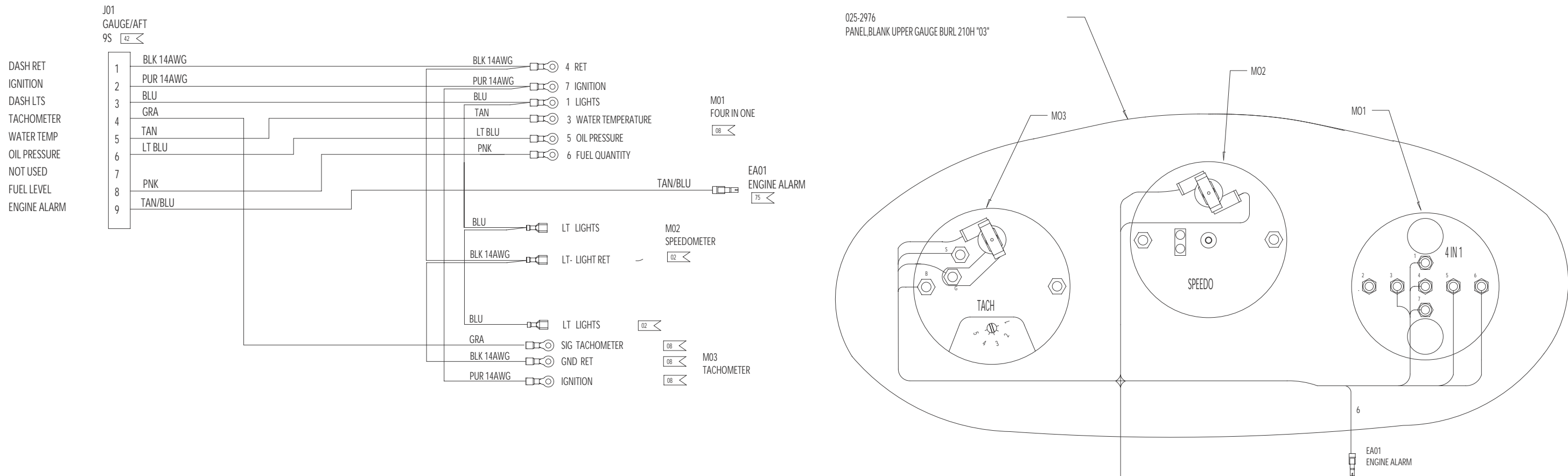

### FOUR WINNS PARTS LIST

ITEM	PART NUMBER	QUANTITY	DESCRIPTION	FUNCTION	MANUFACTURER
-	028-0454	3	RECEPT,FASTON,,250,16-14	02	AMP
-	028-0189	9	TERM,RING,PG #8,16-14	08	AMP
-	028-0177	8	SOCKET,UMNL,18-14	42	AMP
-	028-1823	1	TERM,BULLET,FEMALE,INS.,156,16-14	75	MOLEX
-	025-2976	1	PANEL,BLANK UPPER GA BURL 210H "03"	-	-
J01	028-0443	1	RECEPT,UMNL,9 CKT	GAUGE/AFT	AMP
MO1	024-0524	1	GAUGE,4 IN 1,GF0223	-	FARIA
MO2	024-0523	1	GAUGE,SPEED (65MPH),SE9972	-	FARIA
MO3	024-0526	1	GAUGE,TACH/HOUR METER (6000RPM),TCH239	-	FARIA

### 210/230/250 HORIZON UPPER GAUGE PANEL ASSEMBLY

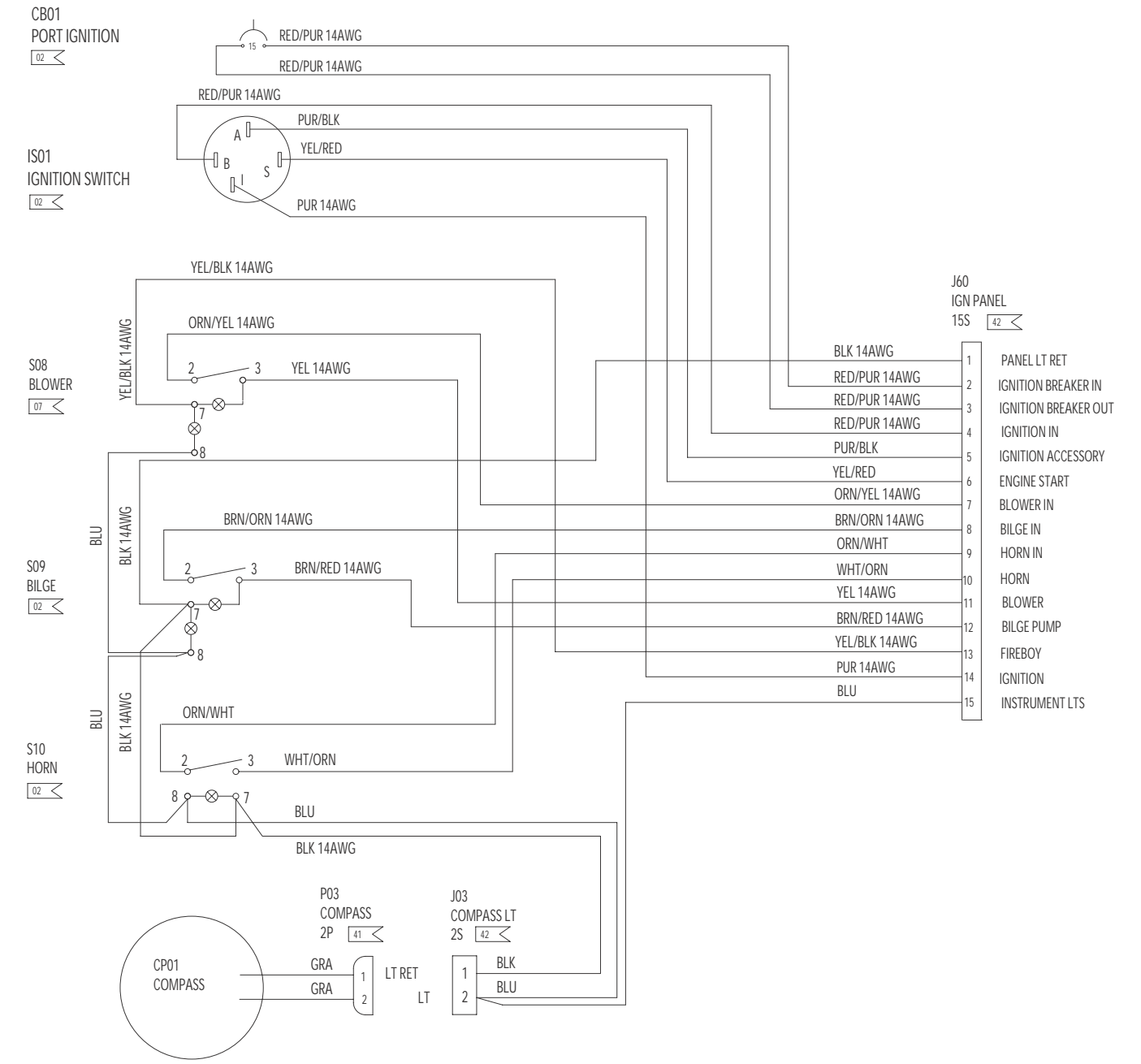
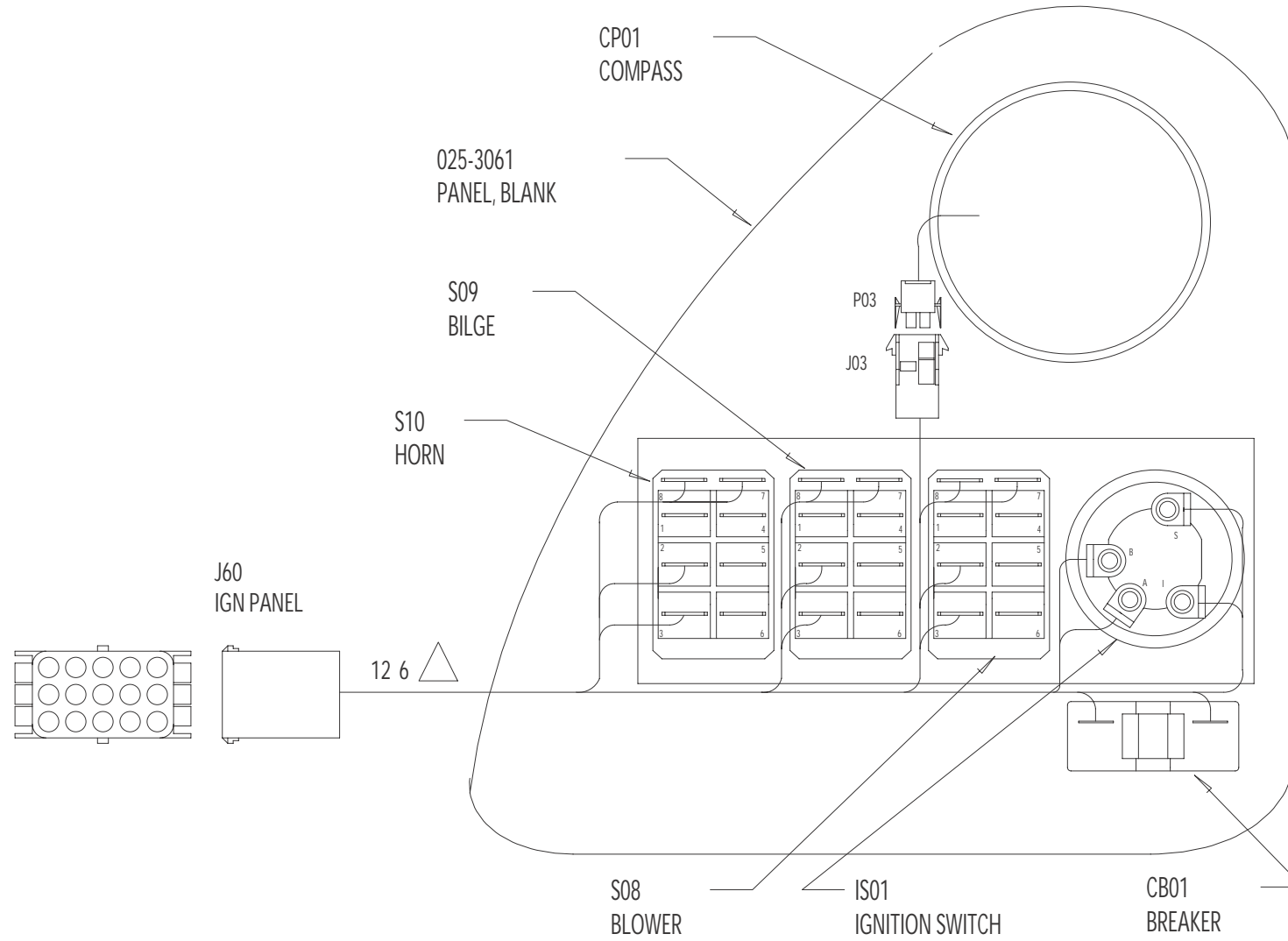

**FOUR WINNS PARTS LIST**

ITEM	PART NUMBER	QUANTITY	DESCRIPTION	FUNCTION	MANUFACTURER
	028-0177	16	TERM,FASTON,.250, 16-14	02	AMP
	028-0179	2	TERM,FASTON,.250, 12-10	07	AMP
	028-0112	2	PIN,UMNL,18-14	41	AMP
	028-0390	17	SOCKET,UMNL,18-14	42	AMP
	025-3061	1	PANEL,BLANK IGN 210/230/250	-	-
J60	028-0446	1	RECEPT,UMNL,15 CKT	IGN PANEL	AMP
J03	028-0441	1	RECEPT,UMNL,2 CKT	COMPASS	AMP
P03	028-0447	1	PLUG,CMNL,2 CKT	COMPASS	AMP
S08	028-1901	1	SWITCH,SPST, OFF-ON	BLOWER	-
S09	028-1897	1	SWITCH,SPST,OFF-ON	BILGE	-
S10	028-1896	1	SWITCH,SPST,OFF-(ON)	HORN	-
IS01	028-1286	1	SWITCH,IGNITION W/ACC	IGN	SIERRA
CB01	028-0467	1	BREAKER, 15A	IGN	MP
CP01	065-1369	1	COMPASS	-	RITCHIE

**210/230/250 HORIZON  
PORT IGNITION/SWITCH  
PANEL ASSEMBLY**



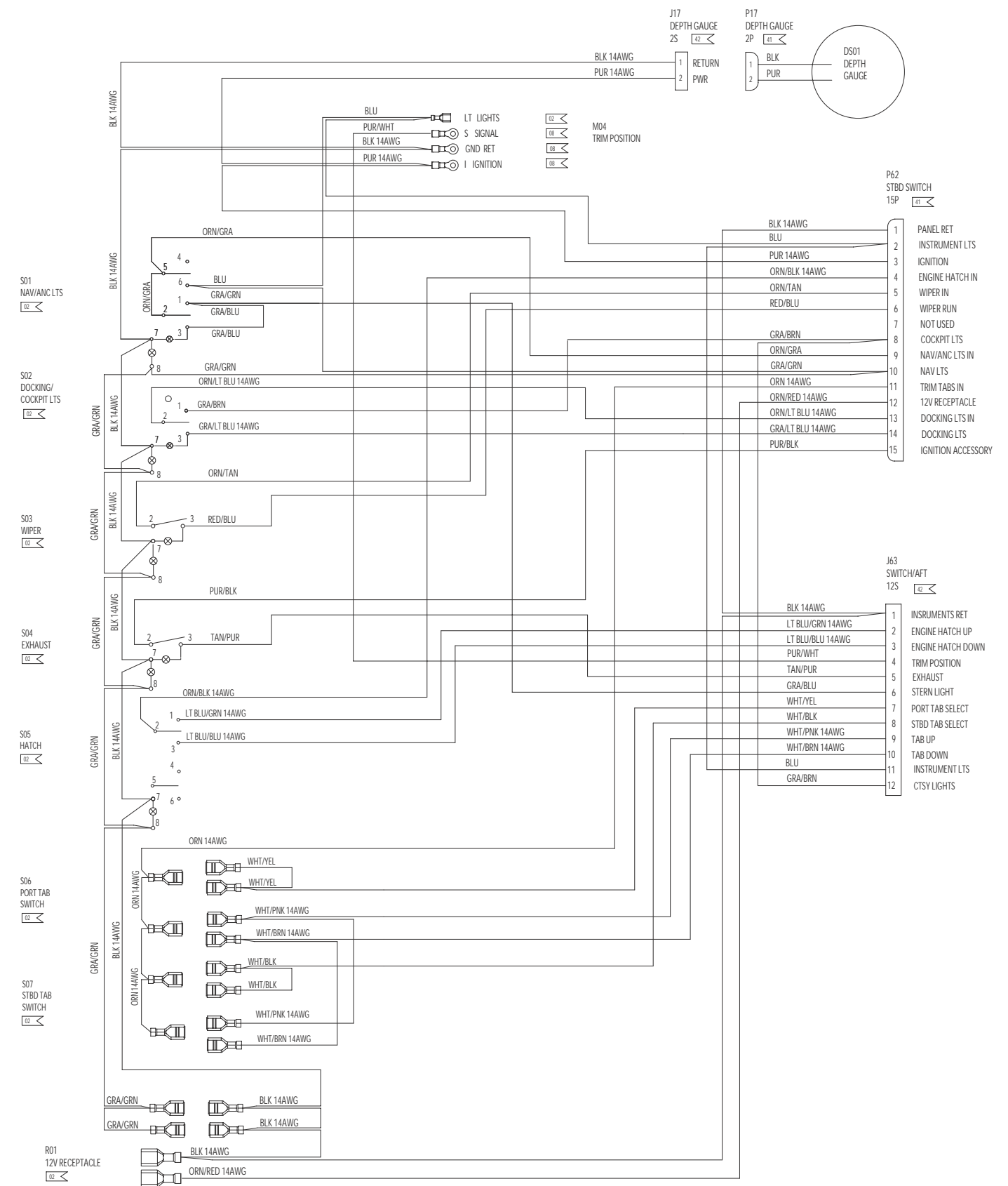
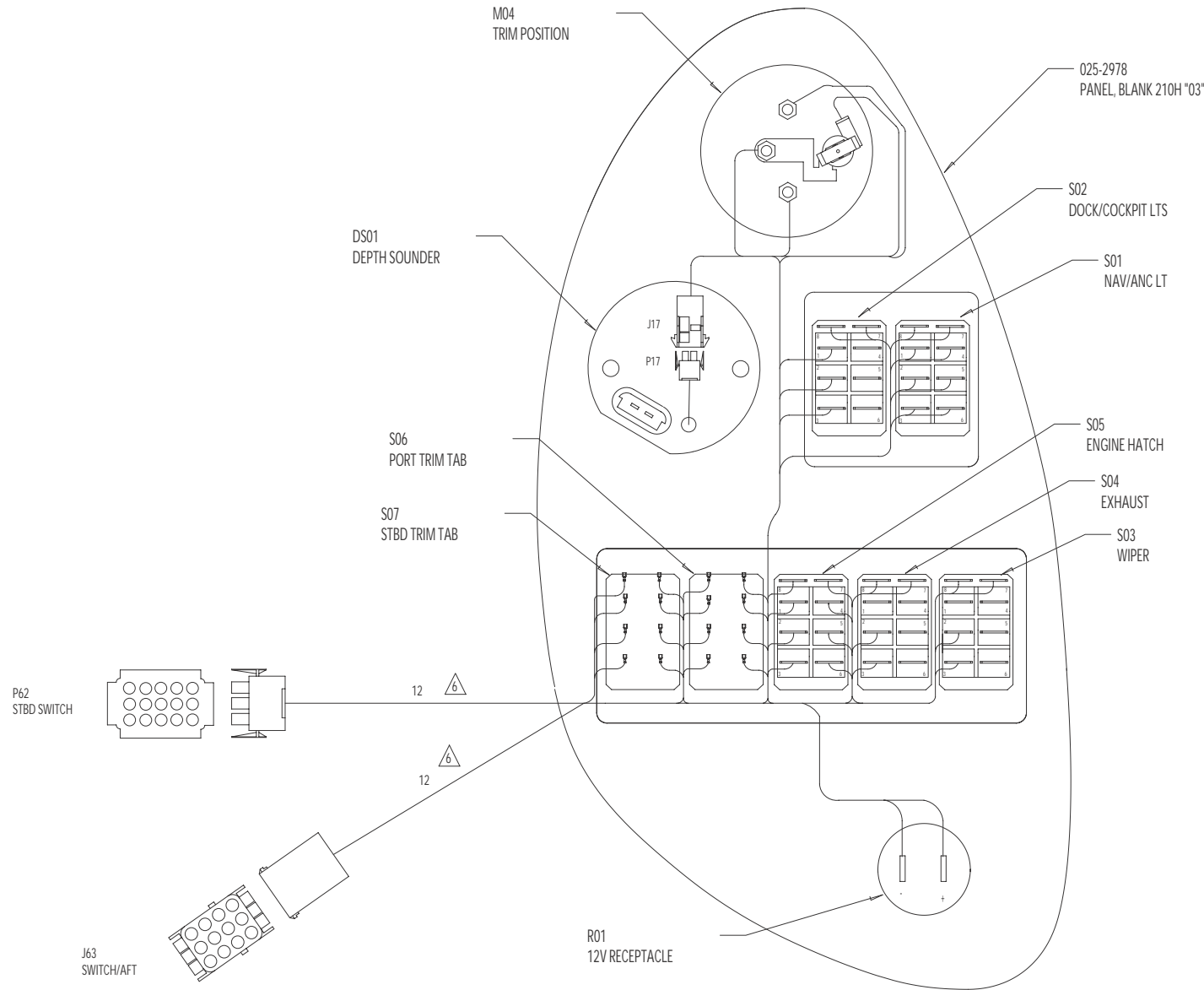

**FOUR WINNS PARTS LIST**

ITEM	PART NUMBER	QUANTITY	DESCRIPTION	FUNCTION	MANUFACTURER
-	028-0177	47	TERM,FASTON, .250, 16-14	02	AMP
-	028-0189	3	TERM,RING,PG,#8,16-14	08	AMP
-	028-0112	17	PIN,UMNL,18-14	41	AMP
-	028-0390	14	SOCKET,UMNL,18-14	42	AMP
-	025-2978	1	PANEL,BLANK, 210H '03'	-	-
P62	028-0452	1	PLUG,UMNL,15 CKT	STBD SWITCH	AMP
J63	028-0451	1	RECEPT,UMNL,12 CKT	SWITCH/AFT	AMP
J03	028-0441	1	RECEPT,UMNL,2 CKT	TRIM GAUGE	AMP
P03	028-0447	1	PLUG,CMNL,2 CKT	TRIM GAUGE	AMP
S01	028-1899	1	SWITCH,DPDT, ON-OFF-ON	NAV/ANC LTS	CARLINGSW
S02	028-1903	1	SWITCH,SPDT,ON-OFF-ON	DOCK/COCKPIT LTS	CARLINGSW
S03	028-1895	1	SWITCH,SPST,OFF-ON	WIPER	CARLINGSW
S04	028-1900	1	SWITCH,SPST,OFF-ON	EXHAUST	CARLINGSW
S05	028-1898	1	SWITCH,DPDT,(ON)-OFF-(ON)	ENGINE HATCH	CARLINGSW
S06	028-0519	1	SWITCH BLANK	-	-
S07	028-0519	1	SWITCH BLANK	-	-
M04	024-0529	1	GAUGE,TRIM FARIA #GP7766	TRIM	FARIA
DS01	028-1748	1	DEPTH SOUNDER,FARIA 2" #DS0109	DEPTH	FARIA
R01	028-1100	1	RECEPTACLE,12VDC	12V DC PLUG	SIERRA

**210/230/250 HORIZON  
STBD HELM  
PANEL ASSEMBLY**  
Page 3

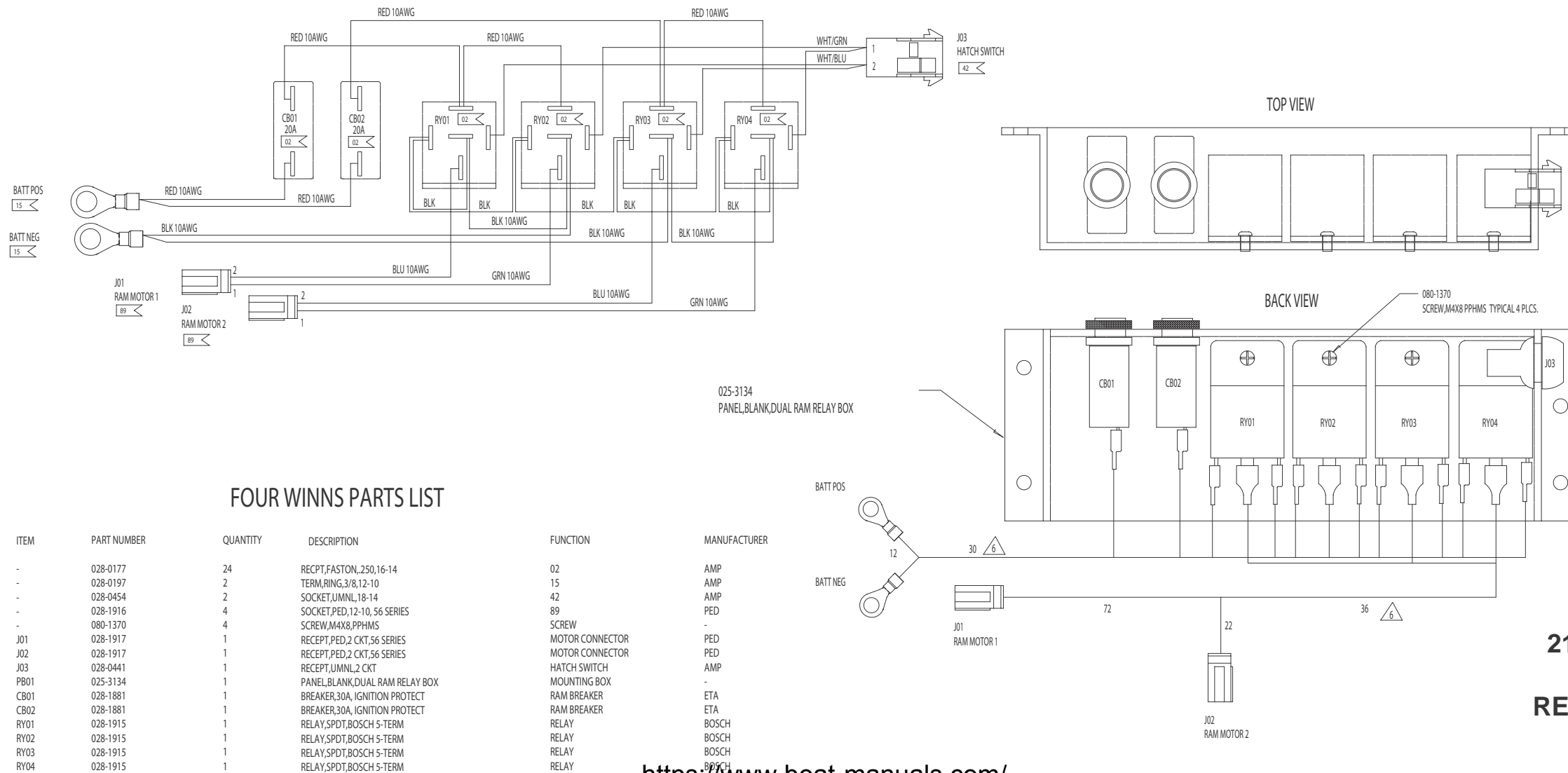
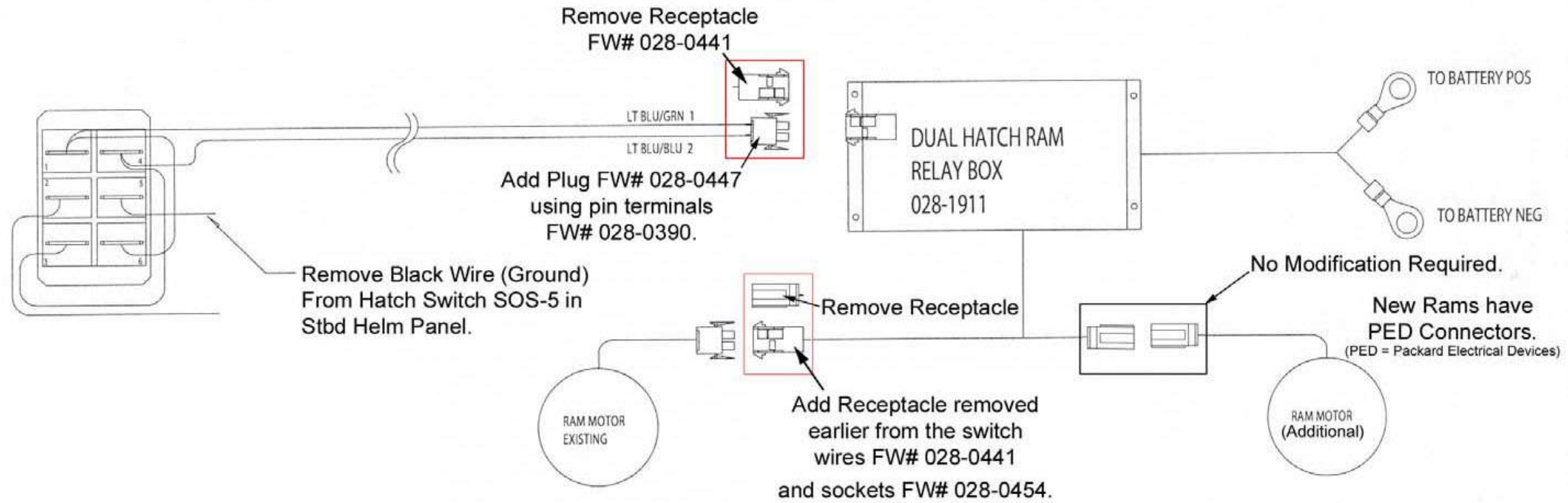

**FOUR WINNS PARTS LIST**

ITEM	PART NUMBER	QUANTITY	DESCRIPTION	FUNCTION	MANUFACTURER
-	028-0177	24	RECPT,FASTON, .250,16-14	02	AMP
-	028-0197	2	TERM,RING,3/8,12-10	15	AMP
-	028-0454	2	SOCKET,UMNL,18-14	42	AMP
-	028-1916	4	SOCKET,PED,12-10, 56 SERIES	89	PED
-	080-1370	4	SCREW,MAX8,PPHMS	-	-
J01	028-1917	1	RECEPT,PED,2 CKT,56 SERIES	MOTOR CONNECTOR	PED
J02	028-1917	1	RECEPT,PED,2 CKT,56 SERIES	MOTOR CONNECTOR	PED
J03	028-0441	1	RECEPT,UMNL,2 CKT	HATCH SWITCH	AMP
PB01	025-3134	1	PANEL,BLANK,DUAL RAM RELAY BOX	MOUNTING BOX	-
CB01	028-1881	1	BREAKER,30A, IGNITION PROTECT	RAM BREAKER	ETA
CB02	028-1881	1	BREAKER,30A, IGNITION PROTECT	RAM BREAKER	ETA
RY01	028-1915	1	RELAY,SPDT,BOSCH 5-TERM	RELAY	BOSCH
RY02	028-1915	1	RELAY,SPDT,BOSCH 5-TERM	RELAY	BOSCH
RY03	028-1915	1	RELAY,SPDT,BOSCH 5-TERM	RELAY	BOSCH
RY04	028-1915	1	RELAY,SPDT,BOSCH 5-TERM	RELAY	BOSCH

**210/230/250 HORIZON  
DUAL HATCH RAM  
RELAY BOX ASSEMBLY**

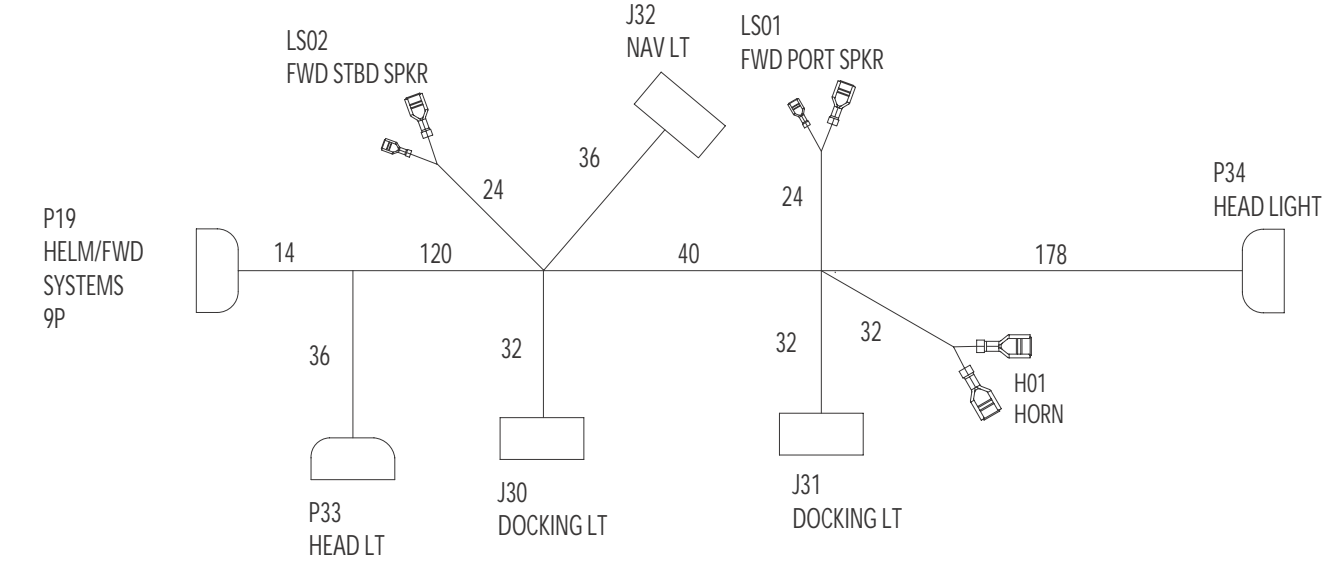
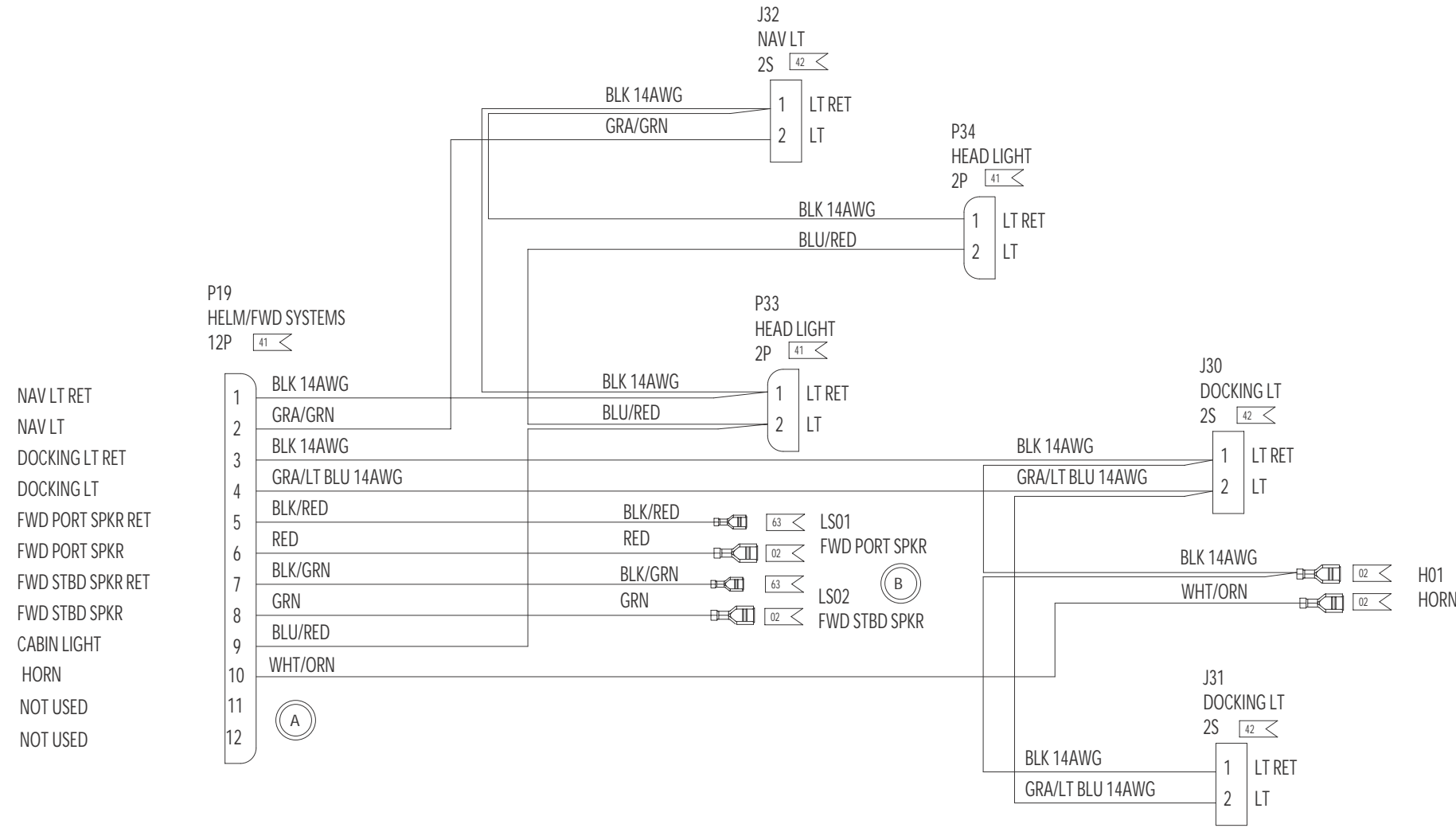

### FOUR WINNS PARTS LIST

ITEM	PART NUMBER	QUANTITY	DESCRIPTION	FUNCTION	MANUFACTURER
-	028-0177	4	TERM,FASTON,,250, 16-14	02	AMP
-	028-0390	14	PIN,UMNL,18-14	41	AMP
-	028-0454	6	SOCKET,UMNL,18-14	42	AMP
-	028-1288	2	FASTON,,205,18-14	63	AMP
J30	028-0441	1	RECEPT,UMNL,2 CKT	DOCKING LT	AMP
J31	028-0441	1	RECEPT,UMNL,2 CKT	DOCKING LT	AMP
J32	028-0441	1	RECEPT,UMNL,2 CKT	NAV LT	AMP
P19	028-0451	1	PLUG,UMNL,12 CKT	HELM/FWD SYSTEMS	AMP
P33	028-0447	1	PLUG,CMNL,2 CKT	CABIN LT	AMP
P34	028-0447	1	PLUG,CMNL,2 CKT	CABIN LT	AMP
LS01	--	REF	SPEAKER	FWD PORT SPKR	--
LS02	--	REF	SPEAKER	FWD STBD SPKR	--
H01	--	REF	HORN	HORN	--

### 210/230/250 HORIZON FORWARD SYSTEMS HARNESS ASSEMBLY

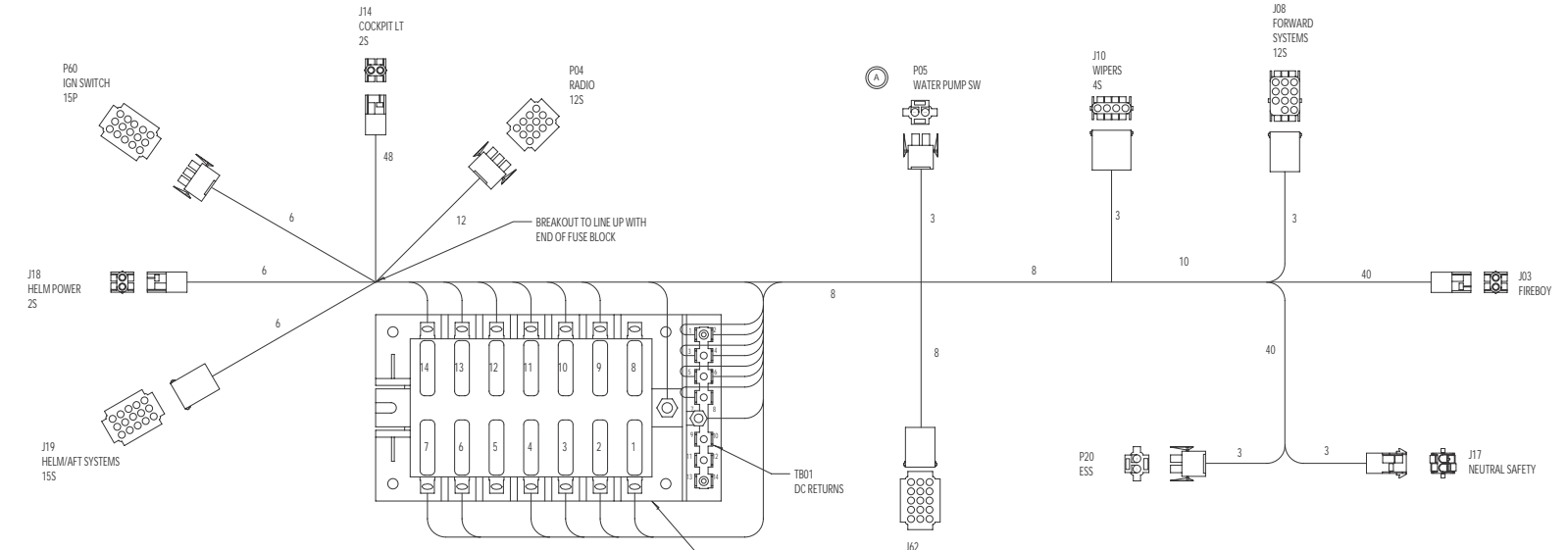
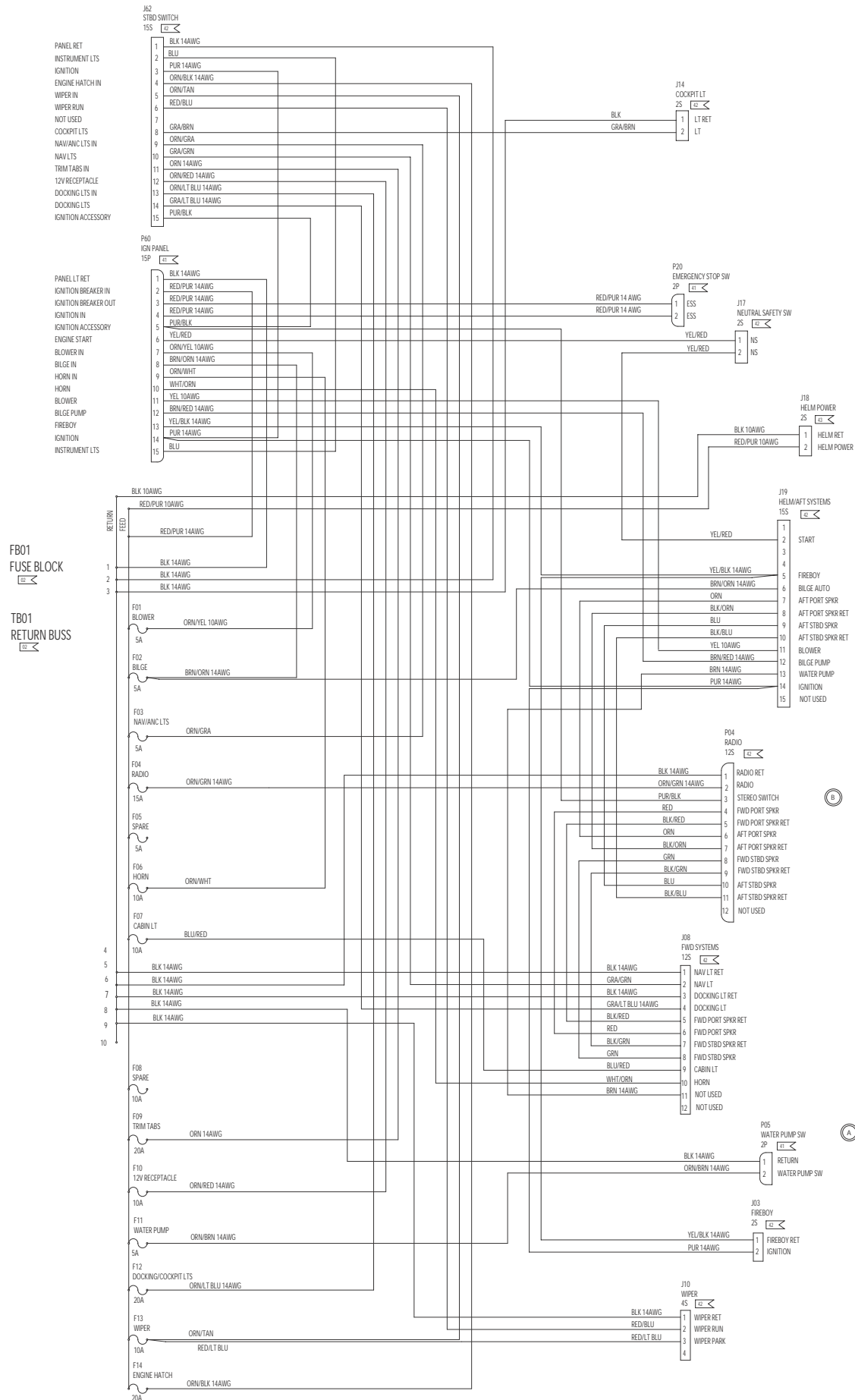

- FUSE SCHEDULE**
1. BLOWER 5A
  2. BILGE 5A
  3. NAV/ANC LTS. 5A
  4. RADIO 20A
  5. SPARE 5A
  6. HORN 10A
  7. CABIN LTS 10A
  8. SPARE 10A
  9. TRIM TABS 20A
  10. 12V RECEPTACLE 10A
  11. FRESH WATER PUMP 5A
  12. DOCKING/COCKPIT LTS 20A
  13. WIPER 10A
  14. ENGINE HATCH 20A

**FOUR WINNS PARTS LIST**

ITEM	PART NUMBER	QUANTITY	DESCRIPTION	FUNCTION	MANUFACTURER
	028-0177	21	TERM FASTON .250,18-14	02	AMP
	028-0390	30	PN UMNL 18-14	41	AMP
	028-0454	47	SOCKET UMNL 18-14	42	AMP
	028-0455	2	SOCKET UMNL 12-10	43	AMP
F01	028-0507	1	FUSE ATC 5A	BLOWER	AMP
F02	028-0507	1	FUSE ATC 5A	BILGE	AMP
F03	028-0507	1	FUSE ATC 5A	NAV/ANC LTS	AMP
F04	028-0511	1	FUSE ATC 20A	RADIO	BUSS
F05	028-0507	1	FUSE ATC 5A	SPARE	BUSS
F06	028-0509	1	FUSE ATC 10A	HORN	BUSS
F07	028-0509	1	FUSE ATC 10A	CABIN LTS	BUSS
F08	028-0509	1	FUSE ATC 10A	SPARE	BUSS
F09	028-0511	1	FUSE ATC 20A	TRIM TABS	BUSS
F10	028-0509	1	FUSE ATC 10A	12V RECEPTACLE	BUSS
F11	028-0507	1	FUSE ATC 5A	FRESH WATER PUMP	BUSS
F12	028-0511	1	FUSE ATC 20A	DOCKING/COCKPIT LTS	BUSS
F13	028-0509	1	FUSE ATC 10A	WIPER	BUSS
F14	028-0511	1	FUSE ATC 20A	ENGINE HATCH	BUSS
FB01	028-0505	1	FUSE BLOCK 14 POS W/GROUND	HELM FUSE BLOCK	SIERRA
J03	028-0441	1	RECEPT UMNL 2 CKT	FIREBOY	AMP
J08	028-0445	1	RECEPT UMNL 12 CKT	FWD SYSTEMS	AMP
J10	028-0442	1	RECEPT UMNL 4 CKT	WIPER	AMP
J14	028-0441	1	RECEPT UMNL 2 CKT	COCKPIT LT	AMP
J17	028-0441	1	RECEPT UMNL 2 CKT	NEUTRAL SAFETY SWITCH	AMP
J18	028-0441	1	RECEPT UMNL 2 CKT	HELM POWER	AMP
J19	028-0446	1	RECEPT UMNL 15 CKT	HELM/AFT SYSTEMS	AMP
J62	028-0446	1	RECEPT UMNL 15 CKT	STBD SWITCH	AMP
P04	028-0451	1	PLUG UMNL 12 CKT	RADIO	AMP
P05	028-0447	1	PLUG UMNL 2 CKT	WATER PUMP SW	AMP
P20	028-0447	1	PLUG UMNL 2 CKT	ESS SWITCH	AMP
P60	028-0452	1	PLUG UMNL 15 CKT	IGNITION PANEL	AMP
TB01	-	REF	RETURN BUSS	HELM RET	-

**210/230/250 HORIZON  
HELM SYSTEMS  
HARNESS ASSEMBLY**

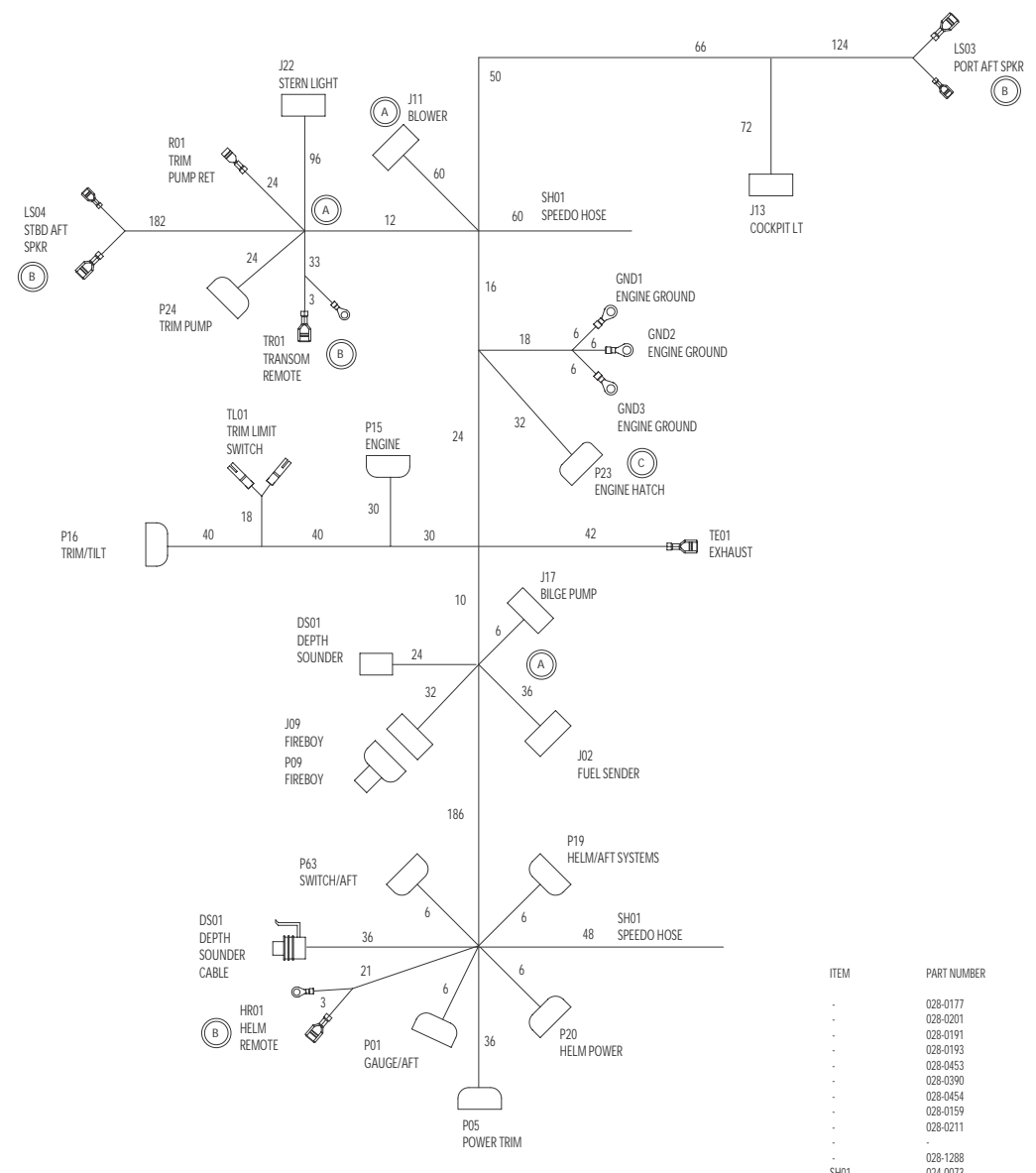
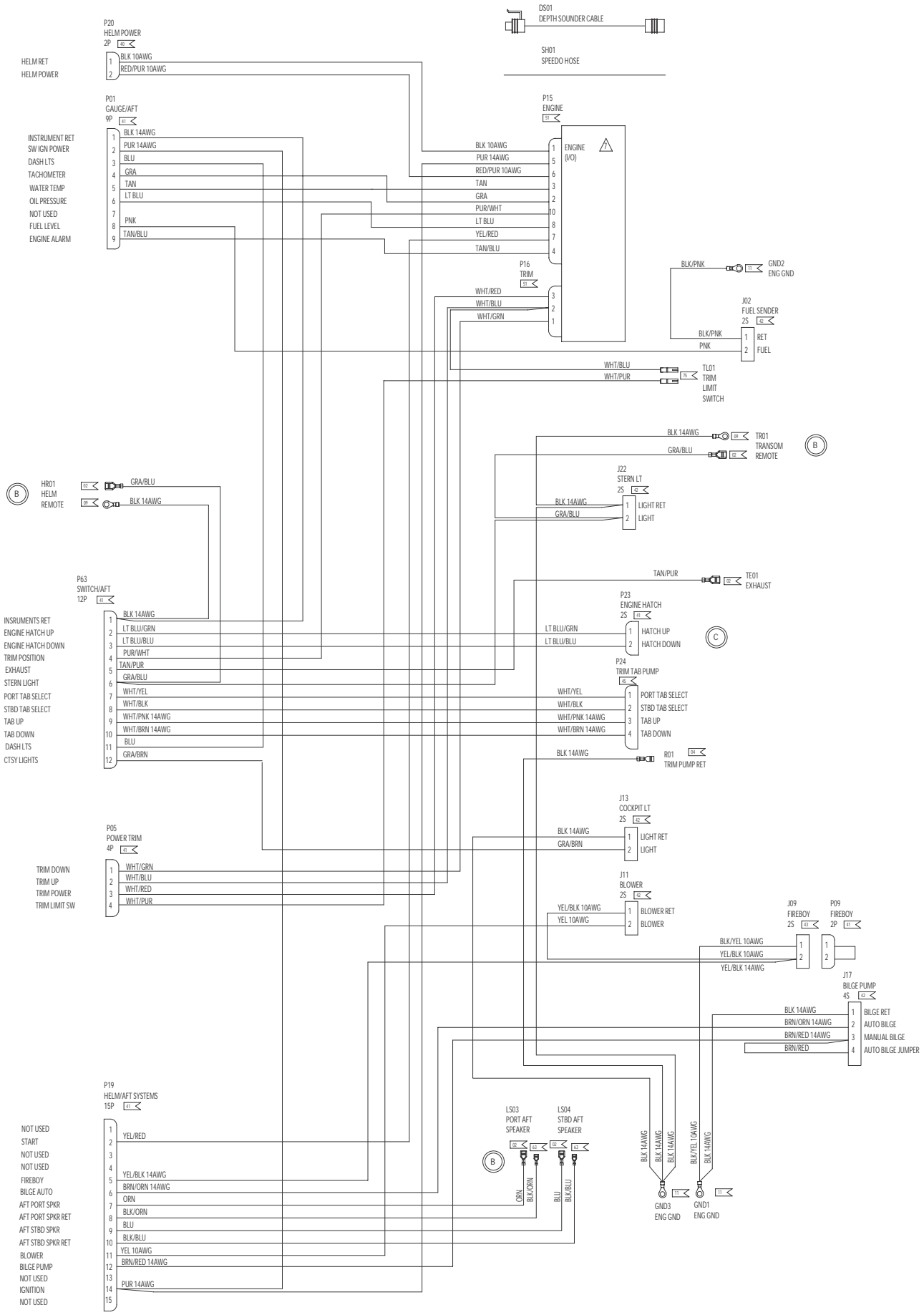

**FOUR WINNS PARTS LIST**

ITEM	PART NUMBER	QUANTITY	DESCRIPTION	FUNCTION	MANUFACTURER
-	028-0177	4	TERM.FASTON, 250.18-14	02	AMP
-	028-0201	1	TAB.FASTON.UF, 250.16-14	04	AMP
-	028-0191	2	TERM.RING.#10.16-14	09	AMP
-	028-0193	3	TERM.RING.3/8.16-14	11	AMP
-	028-0453	2	PIN.U/MINL.12-10	40	AMP
-	028-0390	3	PIN.U/MINL.18-14	41	AMP
-	028-0454	33	SOCKET.U/MINL.18-14	42	AMP
-	028-0159	18	SOCKET.C/MINL.20-14	45	AMP
-	028-0211	2	RECEPT.SOCKE.T, 156.16-14	46	AMP
-	-	13	VENDOR TERMINATED	51	-
-	028-1208	4	FASTON, 205.18-14	63	AMP
DS01	024-0073	1	SPEEDO HOSE NEW AGE #C1101033	-	NEW AGE IND
-	027-2199	1	CABLE.25' TRANSDUCER HN0337	-	FARA/TALON
TE01	-	REF	HULL EXHAUST	ENGINE EXHAUST	-
GND01	-	REF	ENGINE GROUND	ENGINE GROUND	-
GND02	-	REF	ENGINE GROUND	ENGINE GROUND	-
GND03	-	REF	ENGINE GROUND	ENGINE GROUND	-
J02	028-0441	1	RECEPT.U/MINL.2 CXT	FUEL SENDER	AMP
J09	028-0441	1	RECEPT.U/MINL.2 CXT	FIREBOY	AMP
J11	028-0441	1	RECEPT.U/MINL.2 CXT	BLOWER	AMP
J13	028-0441	1	RECEPT.U/MINL.2 CXT	COCKPIT LT	AMP
J17	028-0442	1	RECEPT.U/MINL.4 CXT	BILGE PUMP	AMP
J22	028-0441	1	RECEPT.U/MINL.2 CXT	STERN LT	AMP
P23	028-0447	1	PLUG.U/MINL.2 CXT	ENGINE HATCH	AMP
LS03	-	REF	SPEAKER	PORT AFT SPKR	-
LS04	-	REF	SPEAKER	STBD AFT SPKR	-
P01	028-0449	1	PLUG.U/MINL.9 CXT	GAUGE/AFT	AMP
P05	028-0448	1	PLUG.U/MINL.4 CXT	POWER TRIM	AMP
P09	028-0447	1	PLUG.U/MINL.20CXT	FIREBOY	AMP
P15	-	1	PLUG.ENGINE I/O	ENGINE	OMC
P16	-	1	PLUG.TRIM/TILT	TRIM/TILT	OMC
P19	028-0452	1	PLUG.U/MINL.15 CXT	HELM/AFT SYSTEMS	AMP
P20	028-0447	1	PLUG.U/MINL.2 CXT	HELM POWER	AMP
P24	028-0111	1	PLUG.C/MINL.4 CXT	TRIM TABS	AMP
P63	028-0451	1	PLUG.U/MINL.12 CXT	SWITCH/AFT	AMP
TL01	-	REF	TRIM LIMIT	TRIM LIMIT SWITCH	-
TR01	-	REF	TRANSDUCER STEREO REMOTE	TRANSDUCER REMOTE LT	-
HR01	-	REF	HELM STEREO REMOTE	HELM REMOTE LT	-

**210/230/250 HORIZON  
AFT SYSTEMS  
HARNES ASSEMBLY**

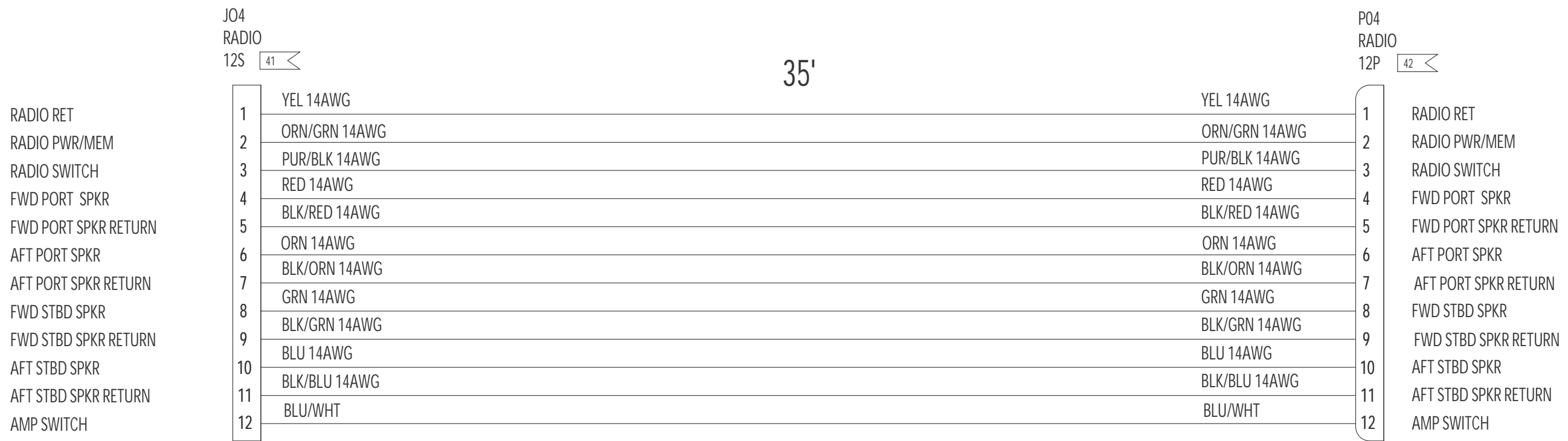

## FOUR WINNS PARTS LIST

ITEM	PART NUMBER	QUANTITY	DESCRIPTION	FUNCTION	MANUFACTURER
-	028-0390	12	PIN,UMNL,18-14	41	AMP
-	028-0454	12	SOCKET,UMNL,18-14	42	AMP
JO4	028-0445	1	RECEPT,UMNL,12 CKT	RADIO EXTENSION	AMP
PO4	028-0451	1	PLUG,UMNL,12 CKT	RADIO	AMP



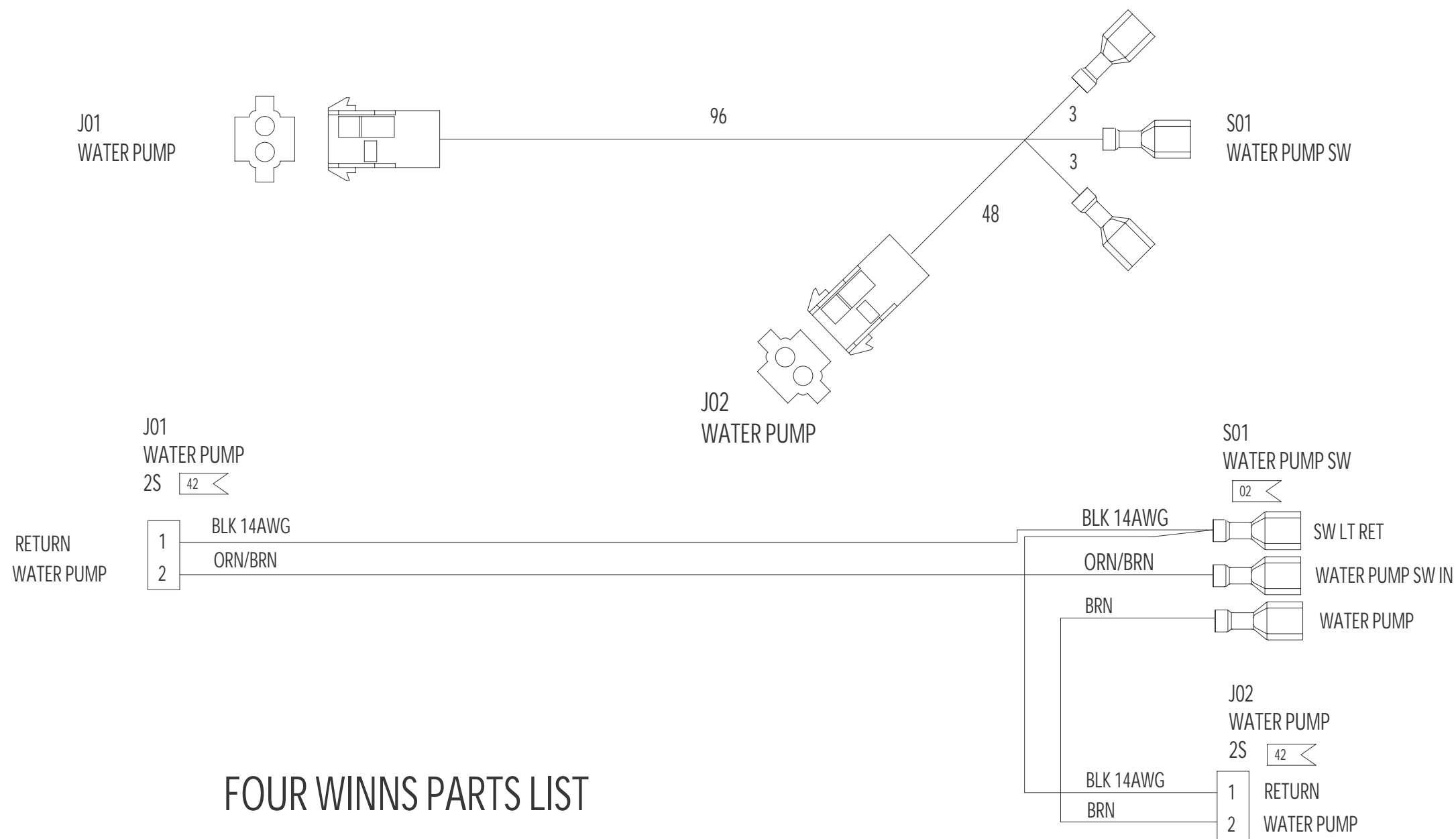

### FOUR WINNS PARTS LIST

ITEM	PART NUMBER	QUANTITY	DESCRIPTION	FUNCTION	MANUFACTURER
-	028-0177	3	RECEPT,FASTON,UF,,250	02	AMP
-	028-0454	4	SOCKET,UMNL,18-14	42	AMP
J01	028-0441	1	PLUG,UMNL,2 CKT	WATER PUMP IN	AMP
J02	028-0441	1	PLUG,UMNL,2 CKT	WATER PUMP	AMP
S01	REF	-	WATER PUMP SWITCH	WATER PUMP SW	-

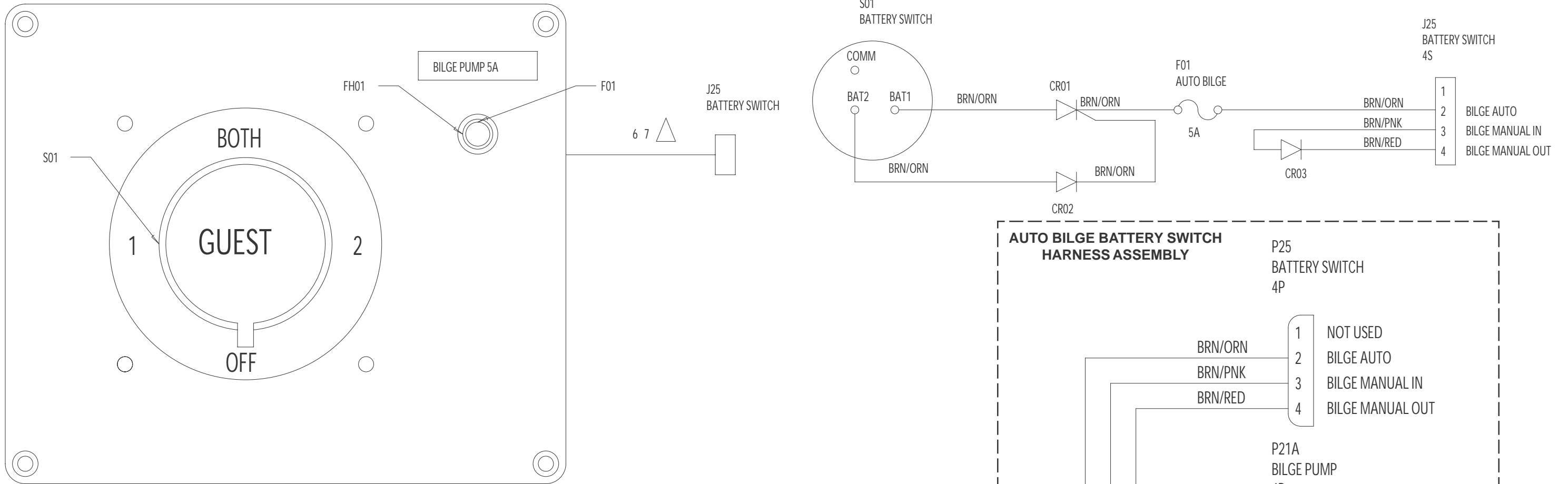

**FOUR WINNS PARTS LIST**

ITEM	PART NUMBER	QUANTITY	DESCRIPTION	FUNCTION	MANUFACTURER
	028-0177	5	TERM,FASTON,.250,18-14	02	AMP
	028-0192	3	TERM,RING,PG,1/4,18-14	10	AMP
	028-0193	2	TERM,RING,PG,3/8,18-14	11	AMP
	028-0454	3	SOCKET,UMNL,18-14	42	AMP
	025-2001	1	PANEL,BLANK,BATTERY SWITCH		
	080-0097	4	NUT,10-24,KEPS S.S.		
		4	SCREW,10-24 X 1 1/4",PRESS IN		
CR01		1	DIODE,18A,1N3208	AUTO BILGE	ITC
CR02		1	DIODE,18A,1N3208	AUTO BILGE	ITC
CR03		1	DIODE,18A,1N3208	MANUAL BILGE	ITC
D01		1	DESIGNATOR,BILGE PUMP 5A	FUSE DESIGNATOR	
F01	028-0184	1	FUSE,AGC,5A	AUTO BILGE	BUSS
FH01		1	FUSE HOLDER,PANEL MOUNT	AUTO BILGE	BUSSMAN
J25	028-0442	1	RECEPT,UMNL,4 CKT	BATTERY SWITCH	AMP
S01	028-0485	1	SWITCH,BATTERY,GUEST,2111-B	BATTERY SWITCH	GUEST

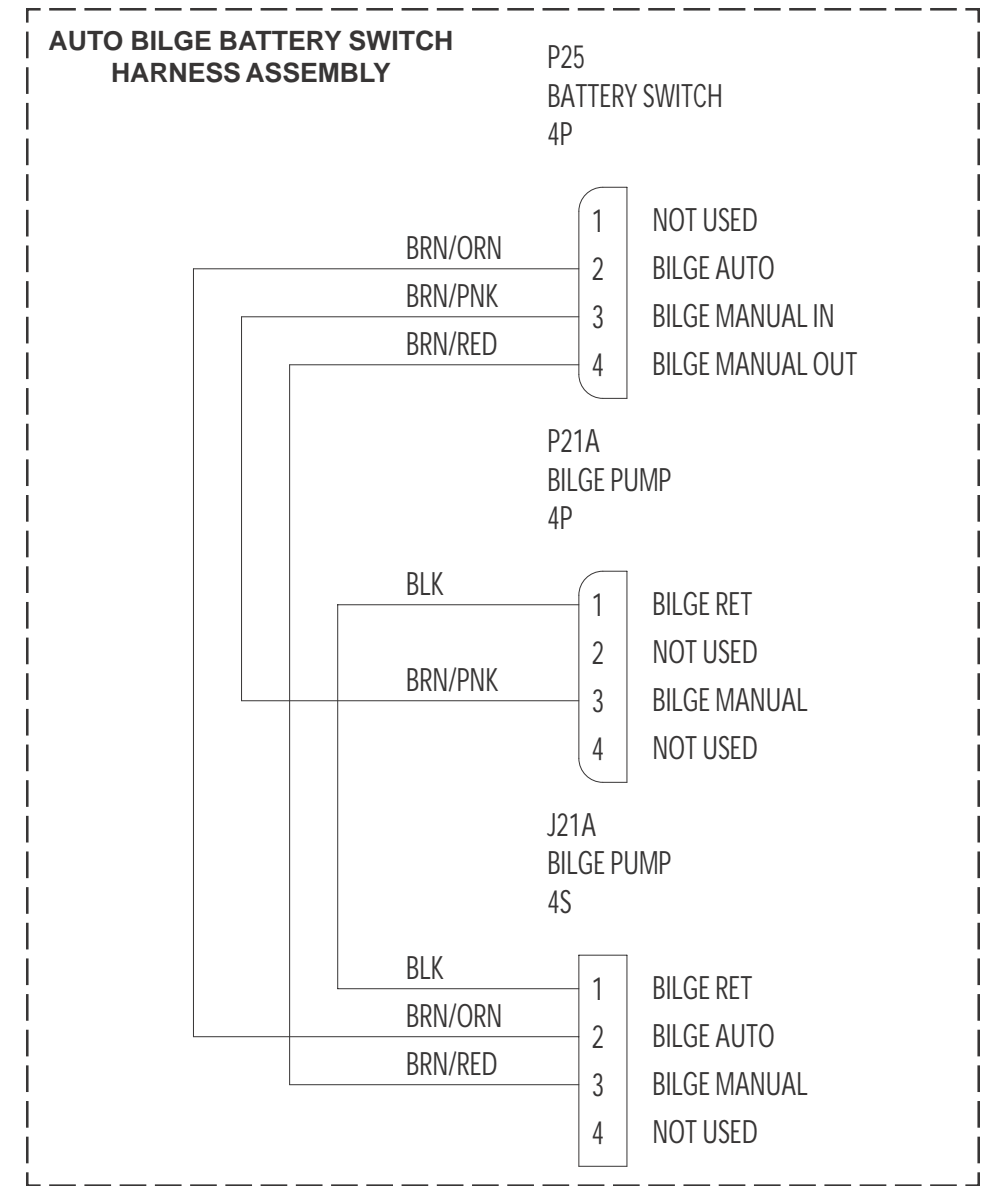

**210/230/250 HORIZON  
OPTIONAL DUAL BATTERY  
W/ SWITCH PANEL ASSEMBLY**

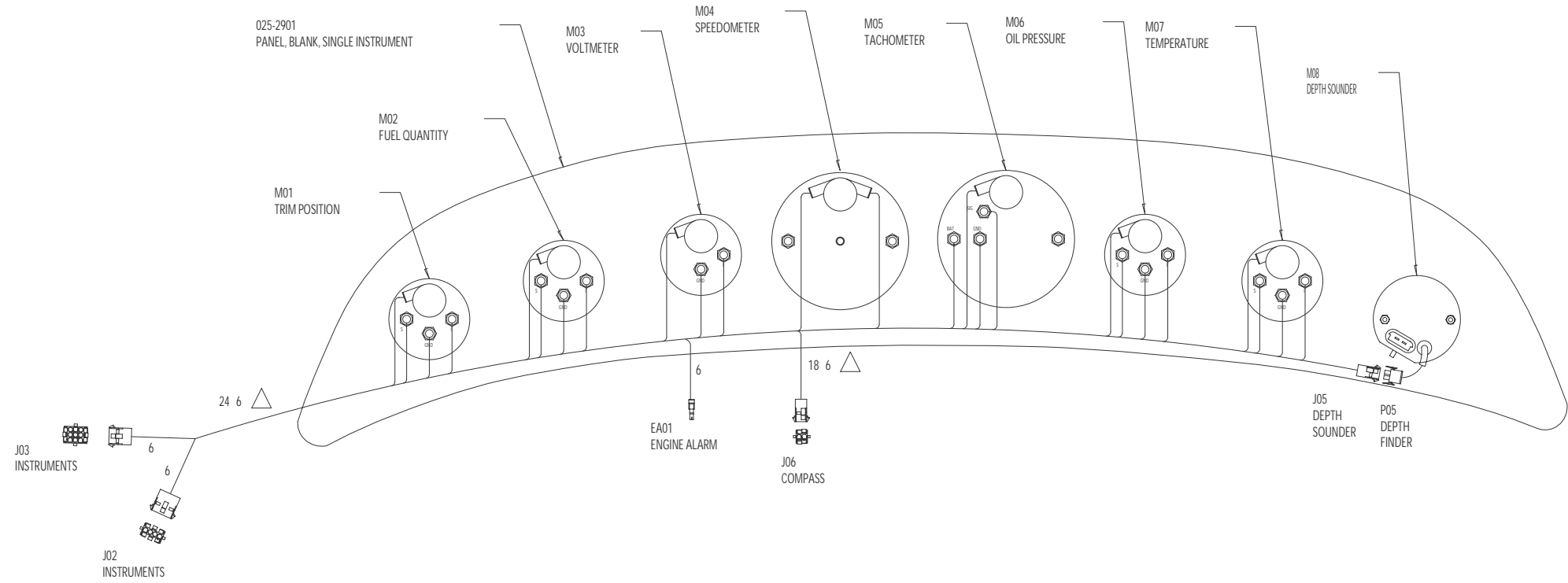
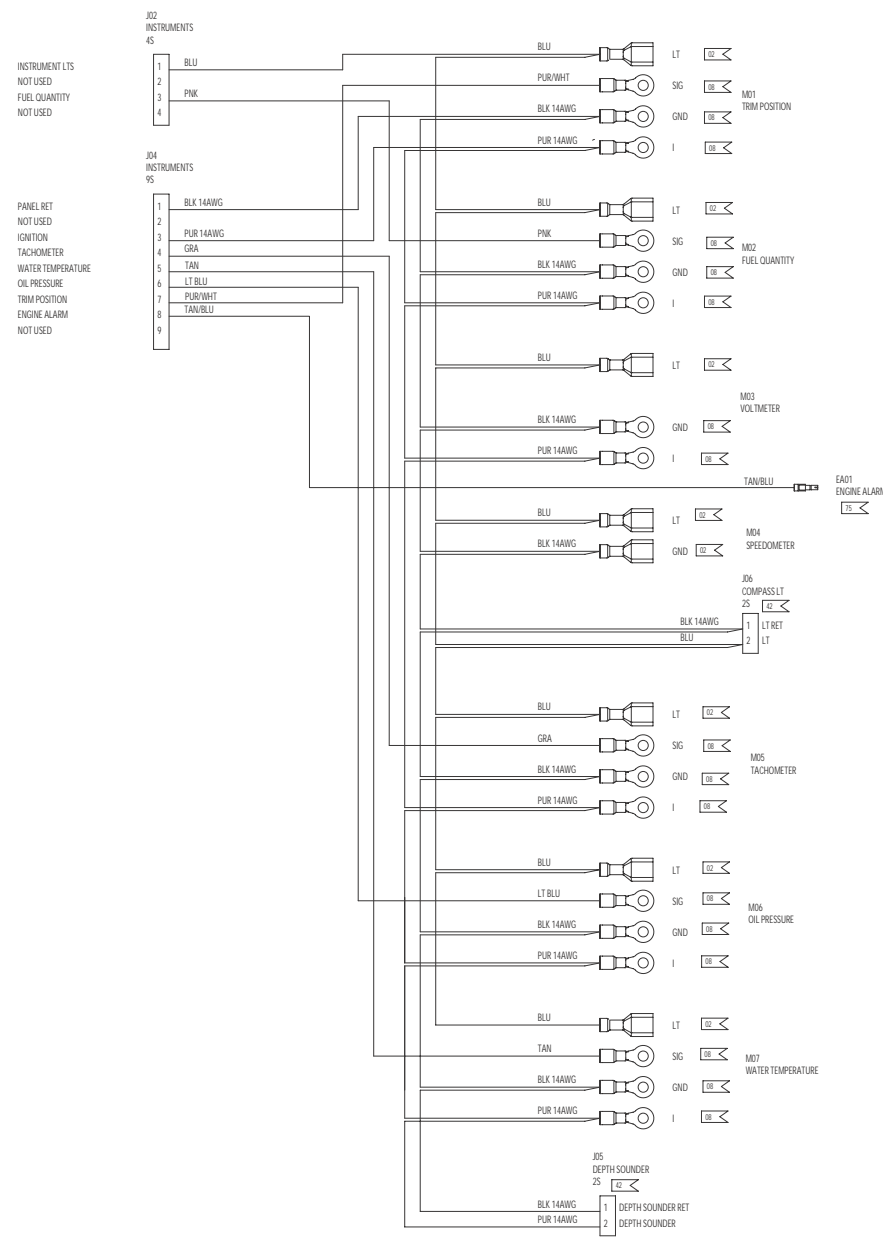

**FOUR WINNS PARTS LIST**

ITEM	PART NUMBER	QUANTITY	DESCRIPTION	FUNCTION	MANUFACTURER
	028-0177	8	TERM,FASTON ,250,18-14	02	AMP
	028-0189	17	TERM,RING:#8,16-14	08	AMP
	028-0454	12	SOCKET,UMNL,18-14	42	AMP
	028-1823	1	TERM,BULLET,FEMALE ,156,INS,16-14	75	MOLEX
	025-2901	1	PANEL,BLANK,SINGLE INSTRUMENT	BLANK	
J02	028-0442	1	RECEPT,UMNL,4 CKT	INSTRUMENTS	AMP
J04	028-0443	1	RECEPT,UMNL,9 CKT	INSTRUMENTS	AMP
J05	028-0441	1	RECEPT,UMNL,2 CKT	DEPTH SOUNDER	AMP
J06	028-0441	1	RECEPT,UMNL,2 CKT	COMPASS	AMP
P05	028-0447	1	PLUG,UMNL,2CKT#A1448ND	DEPTH SOUNDER	AMP
M01	024-0529	1	GAUGE,TRIM FARIA #GP7766	TRIM POSITION	FARIA
M02	024-0532	1	GAUGE,FUEL FARIA #GP7768	FUEL QUANTITY	FARIA
M03	024-0531	1	GAUGE,VOLTMETER #VP7114	VOLTMETER	FARIA
M04	024-0523	1	GAUGE, SPEEDOMETER #SE9972	SPEEDOMETER	FARIA
M05	024-0526	1	GAUGE,TACH 6000 W/HOUR #THC239	TACHOMETER	FARIA
M06	024-0530	1	GAUGE, OIL PRESSURE #GP7767	OIL PRESSURE	FARIA
M07	024-0528	1	GAUGE,WATER TEMPERATURE #GP7765	WATER TEMPERATURE	FARIA
M08	028-1748	1	DEPTH SOUNDER, FARIA 2" #DS0109	DEPTH GAUGE	FARIA
EA01		REF	ENGINE ALARM	ENGINE ALARM	

**280 HORIZON  
SINGLE INSTRUMENTATION  
PANEL ASSEMBLY**

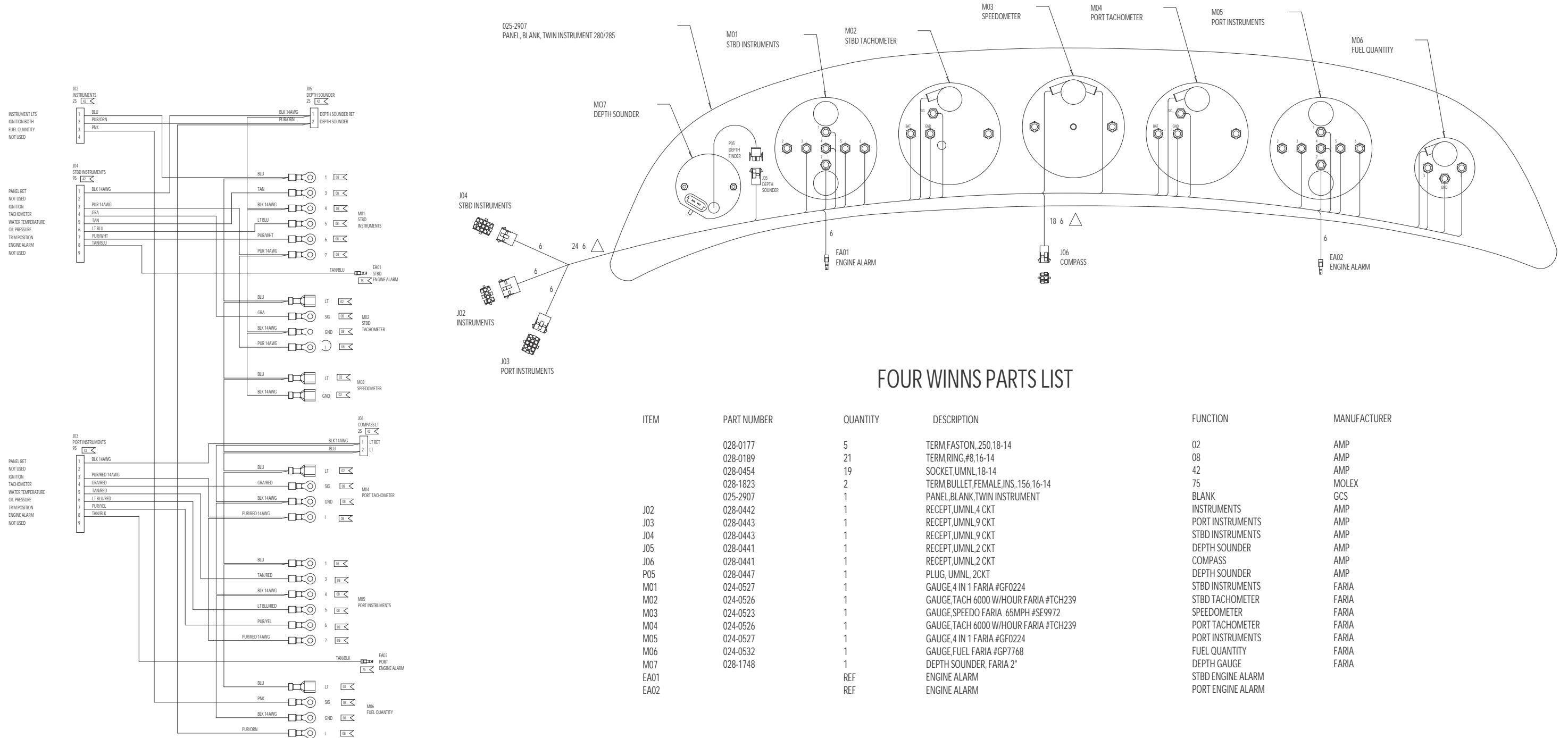

**FOUR WINNS PARTS LIST**

ITEM	PART NUMBER	QUANTITY	DESCRIPTION	FUNCTION	MANUFACTURER
	028-0177	5	TERM,FASTON,.250,18-14	02	AMP
	028-0189	21	TERM,RING,#8,16-14	08	AMP
	028-0454	19	SOCKET,UMNL,18-14	42	AMP
	028-1823	2	TERM,BULLE,FEMALE,INS,.156,16-14	75	MOLEX
	025-2907	1	PANEL,BLANK,TWIN INSTRUMENT	BLANK	GCS
J02	028-0442	1	RECEPT,UMNL,4 CKT	INSTRUMENTS	AMP
J04	028-0443	1	RECEPT,UMNL,9 CKT	PORT INSTRUMENTS	AMP
J05	028-0441	1	RECEPT,UMNL,2 CKT	STBD INSTRUMENTS	AMP
J06	028-0441	1	RECEPT,UMNL,2 CKT	DEPTH SOUNDER	AMP
P05	028-0447	1	PLUG,UMNL,2CKT	COMPASS	AMP
M01	024-0527	1	GAUGE,4 IN 1 FARIA #GF0224	DEPTH SOUNDER	AMP
M02	024-0526	1	GAUGE,TACH 6000 W/HOUR FARIA #TCH239	STBD INSTRUMENTS	FARIA
M03	024-0523	1	GAUGE,SPEEDO FARIA 65MPH #SE9972	STBD TACHOMETER	FARIA
M04	024-0526	1	GAUGE,TACH 6000 W/HOUR FARIA #TCH239	SPEEDOMETER	FARIA
M05	024-0527	1	GAUGE,4 IN 1 FARIA #GF0224	PORT TACHOMETER	FARIA
M06	024-0532	1	GAUGE,FUEL FARIA #GP7768	PORT INSTRUMENTS	FARIA
M07	028-1748	1	DEPTH SOUNDER, FARIA 2"	FUEL QUANTITY	FARIA
EA01		REF	ENGINE ALARM	DEPTH GAUGE	FARIA
EA02		REF	ENGINE ALARM	STBD ENGINE ALARM	
				PORT ENGINE ALARM	

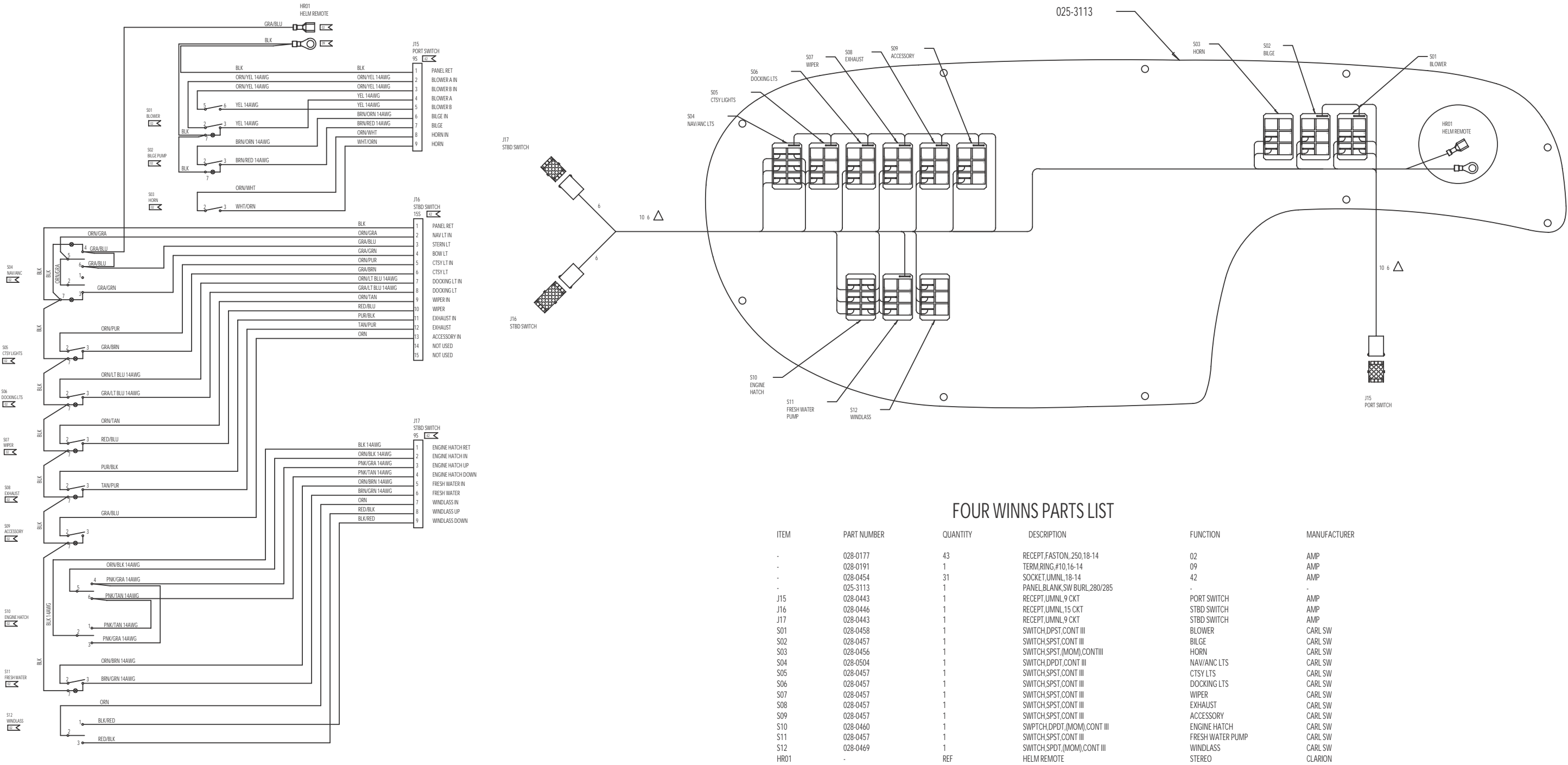

**FOUR WINNS PARTS LIST**

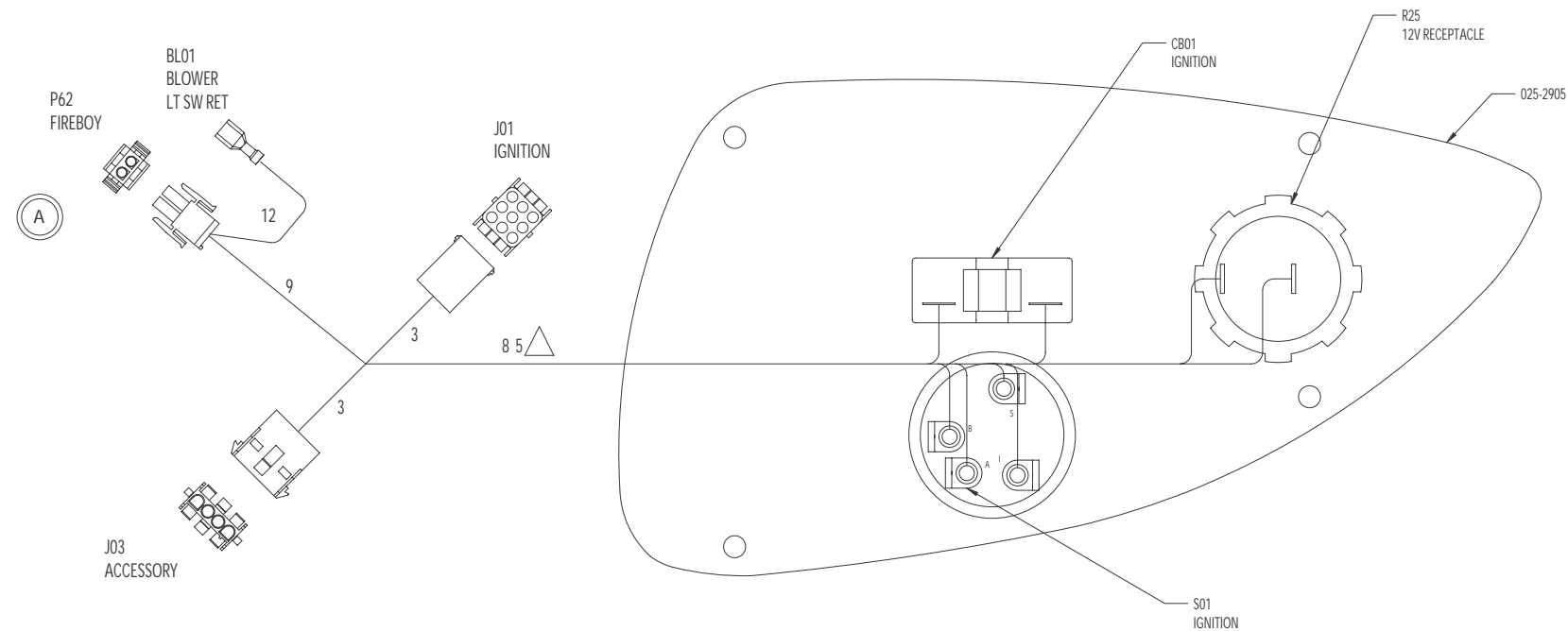

**FOUR WINNS PARTS LIST**

ITEM	PART NUMBER	QUANTITY	DESCRIPTION	FUNCTION	MANUFACTURER
	028-0177	6	TERM,FASTON,250,18-14	02	AMP
	028-0179	3	TERM,FASTON,250,12-10	07	AMP
	028-0390	2	PIN,UMNL,18-14	41	AMP
	028-0454	6	SOCKET,UMNL,18-14	42	AMP
	028-0455	3	SOCKET,UMNL,12-10	43	AMP
	025-2905	1	PANEL,BLANK,SINGLE,IGNITION	BLANK PANEL	
CB01	028-0467	1	BREAKER,15A	IGNITION BREAKER	MP
J01	028-0443	1	RECEPT,UMNL,9 CKT	IGNITION	AMP
J03	028-0442	1	RECEPT,UMNL,4 CKT	ACCESSORY	AMP
S01	028-1286	1	SWITCH,IGNITION W/ACCESSORY	IGNITION	GENERAL
R25	028-1100	1	RECEPT,12V AFI	12V RECEPTACLE	AFI
P62	028-0447	1	PLUG,UMNL,2CKT	FIREBOY	AMP

**FOUR WINNS WIRE LIST**

COLOR	GA	FIRST	PIN	TERM	NOTE	SECOND	PIN	TERM	NOTE	FUNCTION
YEL/RED	16	J01	1	42		S01	S	02		START
RED/PUR	10	J01	2	43		CB01	LINE	07		IGNITION IN
RED/PUR	12	J01	3	43		CB01	LOAD	07		IGNITION BREAKER
RED/PUR	12	J01	4	43		S01	B	07		IGNITION BREAKER
PUR	14	J01	5	42	A	S01	I	02		IGNITION
BLK	14	J03	1	42		R25	-	02		12V RECEPTACLE RET
RED/ORN	14	J03	2	42		R25	+	02		12V RECEPTACLE
PUR/BLK	16	J03	3	42		S01	A	02		IGNITION ACCESSORY
BLK/YEL	16	J03	4	42		P62	1	41	B	FIREBOY RET
BLK/YEL	16	P62	1	41	B	BL01	5	02		BLOWER SW LT RET
PUR	16	P62	2	41		J01	5	42	A	FIREBOY

START  
IGNITION IN  
IGNITION BREAKER  
IGNITION BREAKER  
IGNITION  
NOT USED  
NOT USED  
NOT USED  
NOT USED  
NOT USED

12V RECEPTACLE RET  
12V RECEPTACLE  
IGNITION ACCESSORY  
FIREBOY

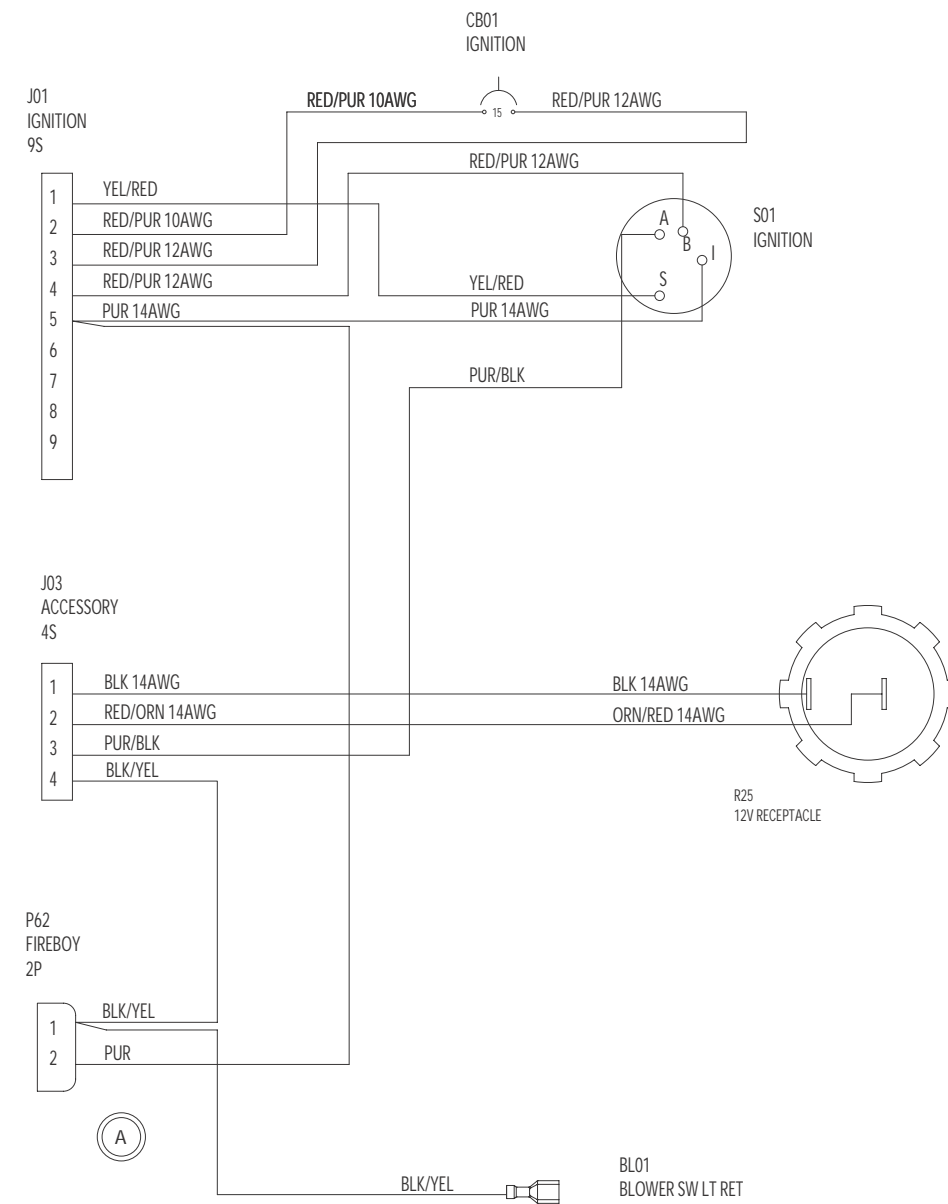



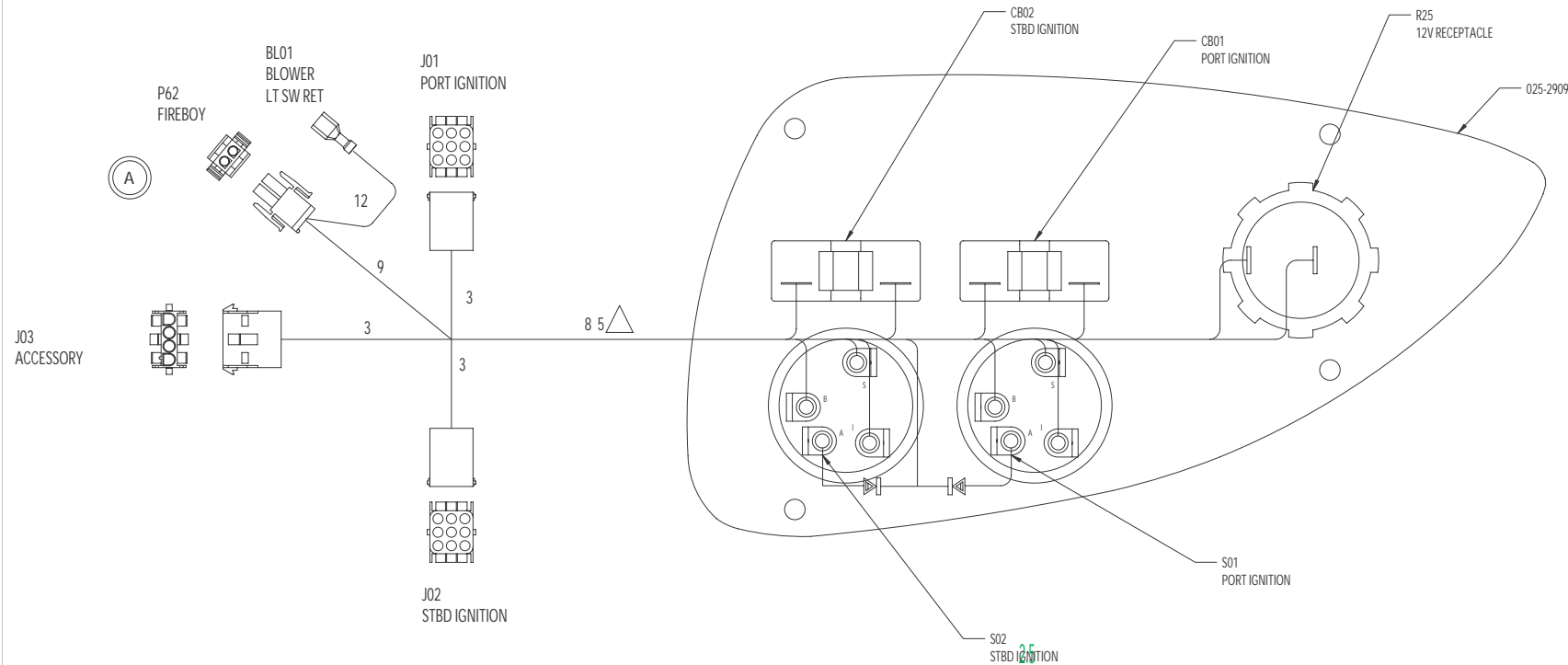

FOUR WINNS PARTS LIST

ITEM	PART NUMBER	QUANTITY	DESCRIPTION	FUNCTION	MANUFACTURER
	028-0177	8	TERM,FASTON, 250,18-14	02	AMP
	028-0179	6	TERM,FASTON, 250,12-10	07	AMP
	028-0390	2	PIN,UMNL, 18-14	41	AMP
	028-0454	7	SOCKET,UMNL,18-14	42	AMP
	028-0455	6	SOCKET,UMNL,12-10	43	AMP
	025-2909	1	PANEL,BLANK,TWIN IGNITION	BLANK PANEL	
CB01	028-0467	1	BREAKER,15A	PORT IGNITION BREAKER	MP
CB02	028-0467	1	BREAKER,15A	STBD IGNITION BREAKER	MP
J01	028-0443	1	RECEPT,UMNL,9 CKT	PORT IGNITION	AMP
J02	028-0443	1	RECEPT,UMNL,9 CKT	STBD IGNITION	AMP
J03	028-0442	1	RECEPT,UMNL,4 CKT	ACCESSORY	AMP
S01	028-1286	1	SWITCH,IGNITION W/ACCESSORY	PORT IGNITION	GENERAL
S02	028-1286	1	SWITCH,IGNITION W/ACCESSORY	STBD IGNITION	GENERAL
R25	028-1100	1	RECEPT,12V AFI	12V RECEPTACLE	AFI
P62	028-0447	1	PLUG,UMNL,2 CKT	FIREBOY	AMP

FOUR WINNS WIRE LIST

COLOR	GA	FIRST	PIN	TERM	NOTE	SECOND	PIN	TERM	NOTE	FUNCTION
YEL/RED	16	J01	1	42		S01	S	02		START
RED/PUR	10	J01	2	43		CB01	LINE	07		IGNITION IN
RED/PUR	12	J01	3	43		CB01	LOAD	07		IGNITION BREAKER
RED/PUR	12	J01	4	43		S01	B	07		IGNITION BREAKER
PUR/RED	14	J01	5	42		S01	I	02		IGNITION
YEL/RED	16	J02	1	42		S02	S	02		START
RED/PUR	10	J02	2	43		CB02	LINE	07		IGNITION IN
RED/PUR	12	J02	3	43		CB02	LOAD	07		IGNITION BREAKER
RED/PUR	12	J02	4	43		S02	B	07		IGNITION BREAKER
PUR	14	J02	5	42		S02	I	02		IGNITION
BLK	14	J03	1	42		R25	-	02		12V RECEPTACLE RET
RED/ORN	14	J03	2	42		R25	+	02		12V RECEPTACLE
PUR/BLK	16	J03	3	42	A	CR03	3	51		IGNITION ACCESSORY
PUR/BLK	16	CR03	1	51		S02	A	02		IGNITION ACCESSORY
PUR/BLK	16	CR03	2	51		S01	A	02		IGNITION ACCESSORY
PUR/BLK	16	J03	3	42	A	P62	2	41		FIREBOY
BLK/YEL	16	J03	4	42		P62	1	41	B	FIREBOY RET
BLK/YEL	16	P62	1	41	B	BL01		02		BLOWER LT SW RET

START  
IGNITION IN  
IGNITION BREAKER  
IGNITION BREAKER  
IGNITION  
NOT USED  
NOT USED  
NOT USED  
NOT USED  
NOT USED

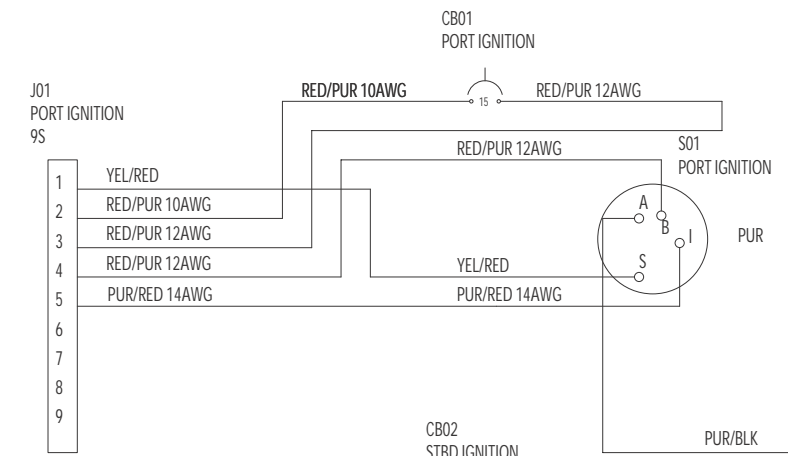

START  
IGNITION IN  
IGNITION BREAKER  
IGNITION BREAKER  
IGNITION  
NOT USED  
NOT USED  
NOT USED  
NOT USED  
NOT USED

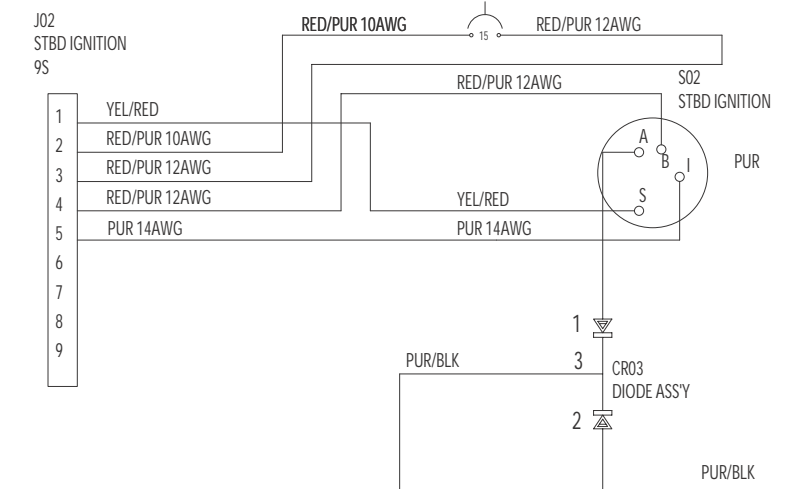

12V RECEPTACLE RET  
12V RECEPTACLE  
IGNITION ACCESSORY  
FIREBOY

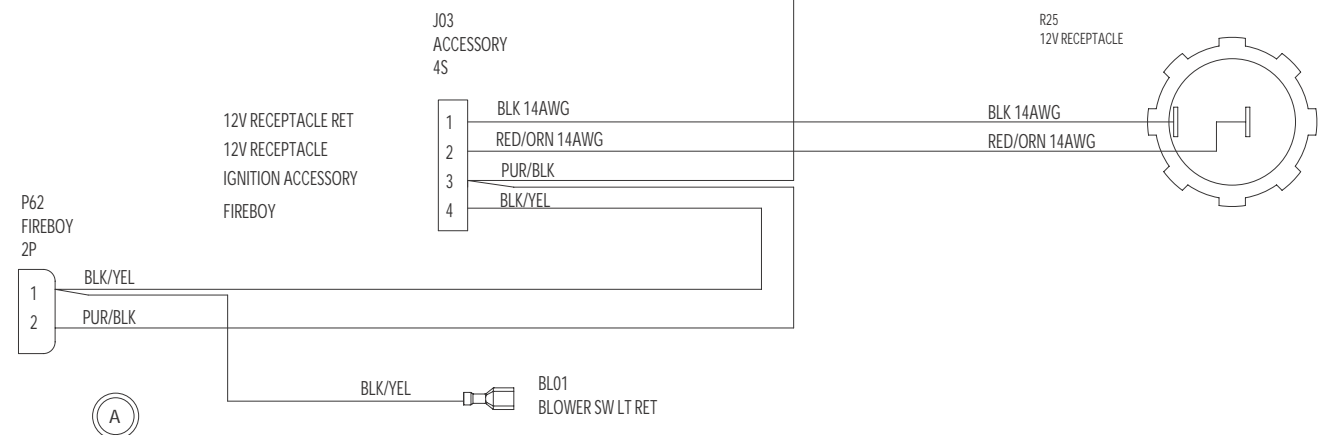

280 HORIZON  
TWIN IGNITION  
PANEL ASSEMBLY

### FOUR WINNS WIRE LIST

COLOR	GA	FIRST	PIN	TERM	NOTE	SECOND	PIN	TERM	NOTE	FUNCTION
ORN	14	P30	1	41		S21	5	02	SA	TAB POWER
WHT/YEL	16	P30	2	41		S20	3	02	SD	PORT TAB SELECT
WHT/BLK	16	P30	3	41		S21	3	02	SE	STBD TAB SELECT
WHT/PNK	14	P30	4	41		S21	4	02	SF	TAB UP
WHT/BRN	14	P30	5	41		S21	6	02	SG	TAB DOWN
ORN	14	S20	5	02	SC	S20	2	02		
ORN	14	S20	5	02	SC	S21	2	02	SB	TAB POWER
ONR	14	S21	2	02	SB	S21	5	02	SA	TAB POWER
WHT/BRN	14	S20	6	02	SG	S21	6	02		TAB DOWN
WHT/PNK	14	S20	4	02	SF	S21	4	02		TAB UP
WHT/YEL	16	S20	3	02	SD	S20	1	02		PORT TAB SELECT
WHT/BLK	16	S21	3	02	SE	S21	1	02		STBD TAB SELECT

### FOUR WINNS PARTS LIST

ITEM	PART NUMBER	QUANTITY	DESCRIPTION	FUNCTION	MANUFACTURER
	028-0177	34	TERM,FASTON, 250,18-14	02	AMP
	028-0390	28	SOCKET,UMNL,18-14	42	AMP
	025-2185	1	PANEL,BLANK,TRIM TABS		
P30	028-0449	1	PLUG,UMNL,9 CKT	TRIM TABS	AMP
S20	028-0460	1	SWITCH,(ON) OFF (ON) CONT III	PORT TAB SELECT	CARL SW
S21	028-0460	1	SWITCH,(ON) OFF (ON) CONT III	STBD TAB SELECT	CARL SW

### REAR PANEL VIEW

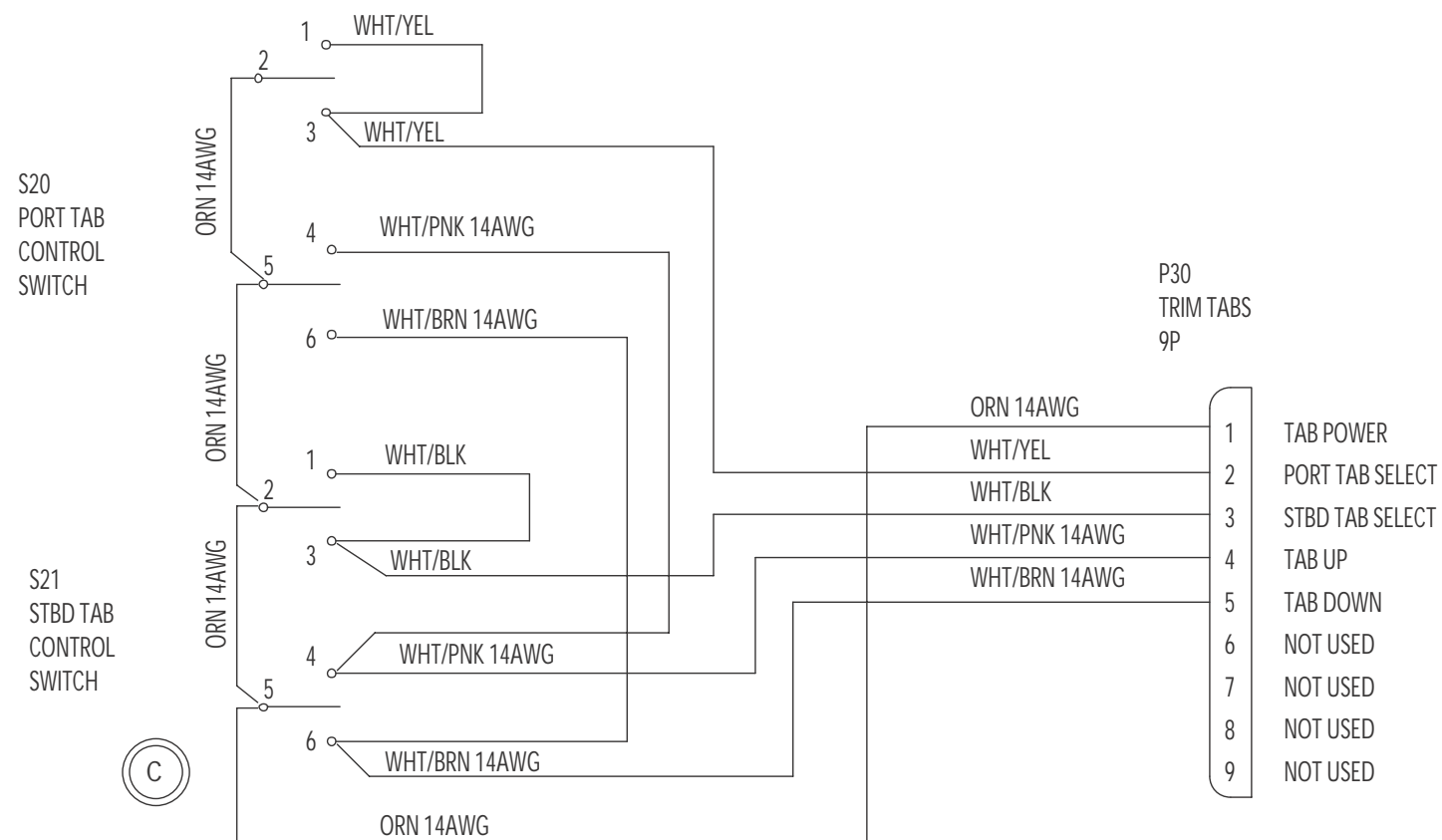
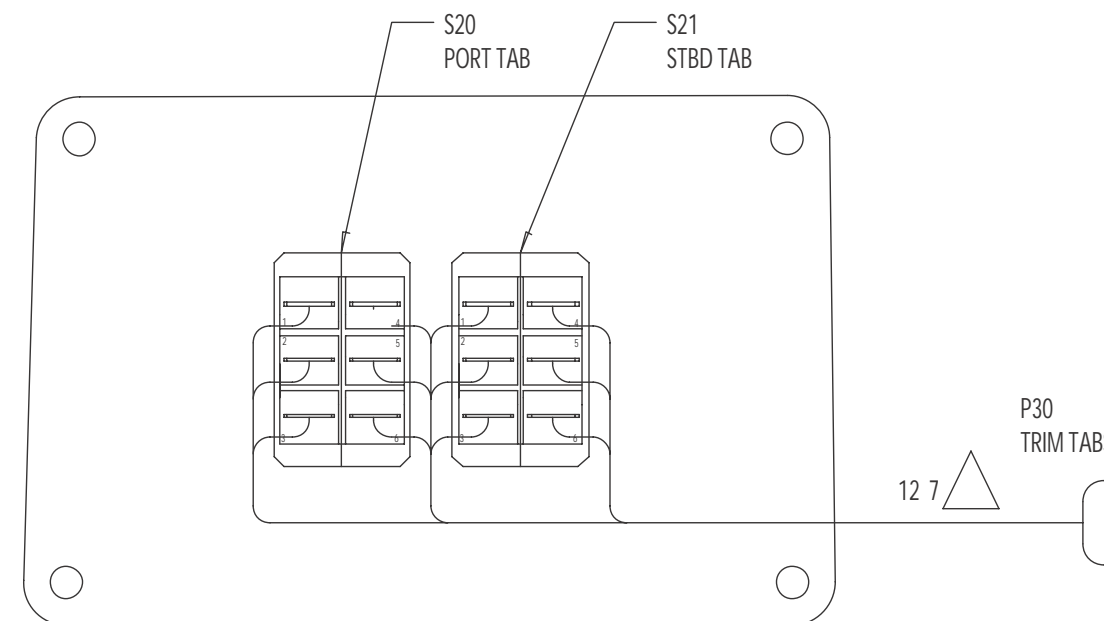

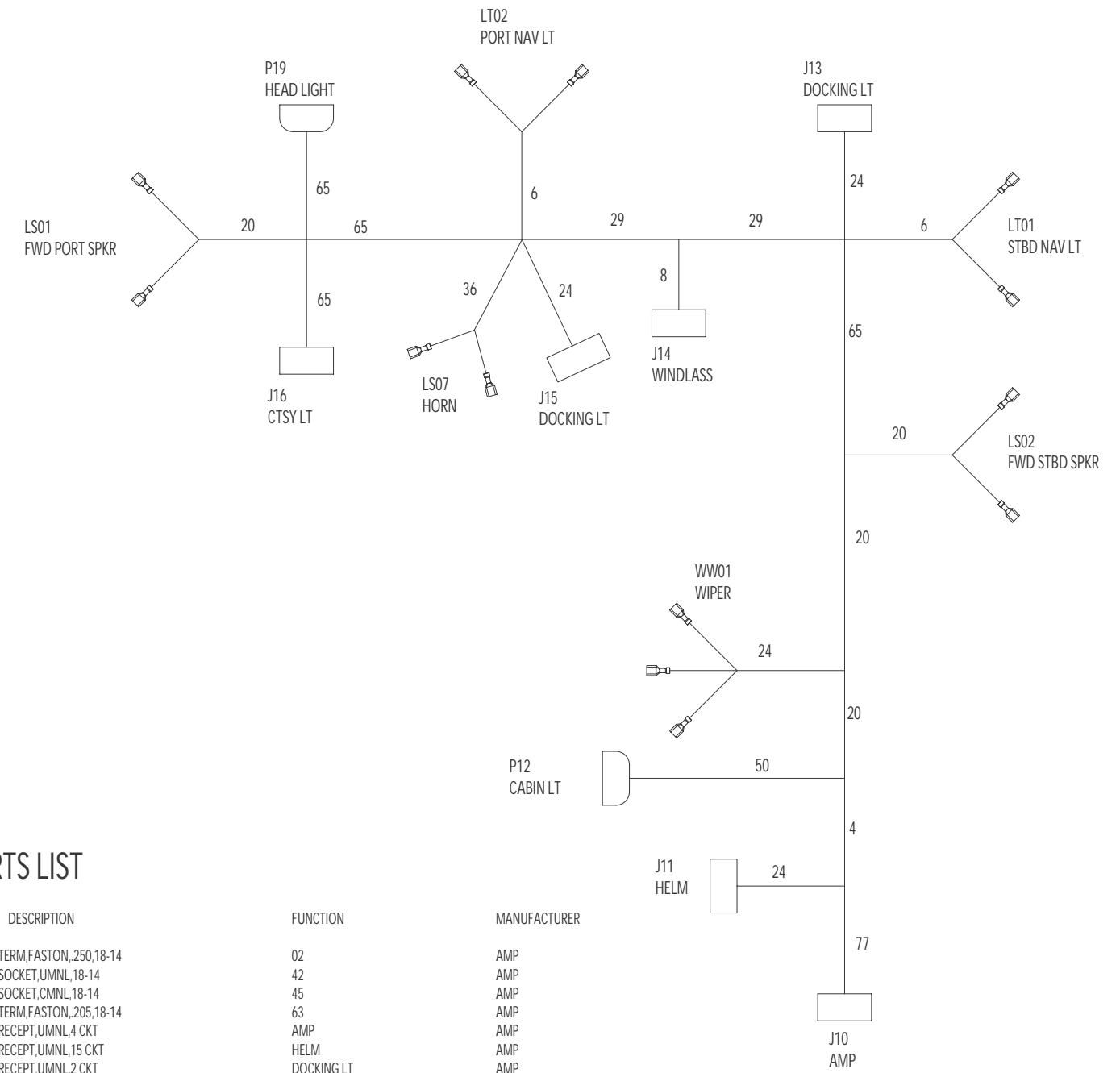
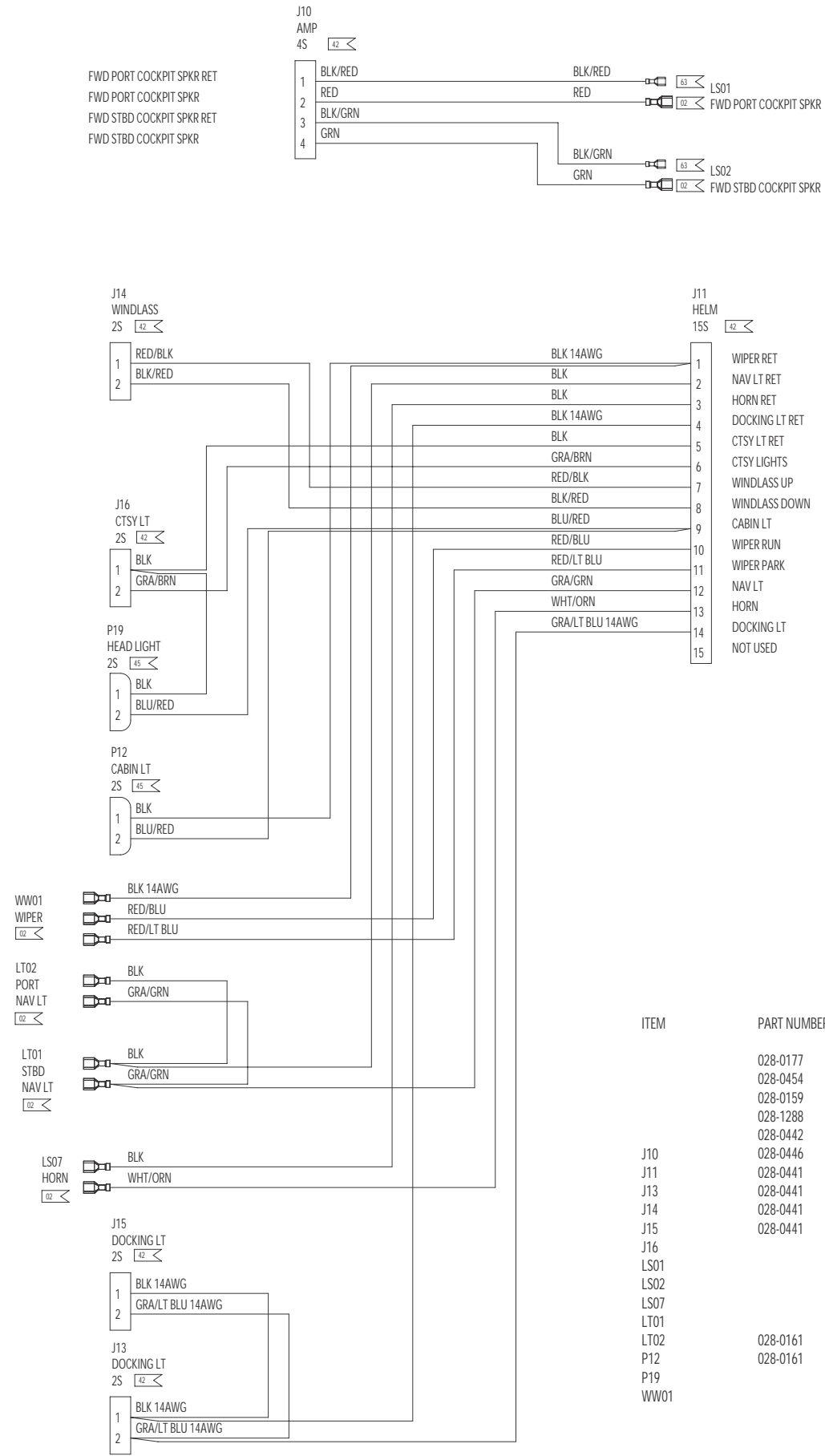

**FOUR WINNS PARTS LIST**

ITEM	PART NUMBER	QUANTITY	DESCRIPTION	FUNCTION	MANUFACTURER
	028-0177	11	TERM,FASTON, 250,18-14	02	AMP
	028-0454	26	SOCKET,UMN1,18-14	42	AMP
	028-0159	4	SOCKET,CMN1,18-14	45	AMP
	028-1288	2	TERM,FASTON, 205,18-14	63	AMP
	028-0442	1	RECEPT,UMN1,4 CKT	AMP	AMP
J10	028-0446	1	RECEPT,UMN1,15 CKT	HELM	AMP
J11	028-0441	1	RECEPT,UMN1,2 CKT	DOCKING LT	AMP
J13	028-0441	1	RECEPT,UMN1,2 CKT	WINDLASS	AMP
J14	028-0441	1	RECEPT,UMN1,2 CKT	DOCKING LT	AMP
J15	028-0441	1	RECEPT,UMN1,2 CKT	CTS Y LT	AMP
J16		REF	SPEAKER	SPEAKER	
LS01		REF	SPEAKER	SPEAKER	
LS02		REF	HORN	HORN	
LS07		REF	LIGHT, BOW SS	NAV LT	
LT01		REF	LIGHT, BOW SS	NAV LT	
LT02	028-0161	1	PLUG,CMN1,2 CKT	CABIN LT	AMP
P12	028-0161	1	PLUG,CMN1,2 CKT	HEAD LT	AMP
P19		REF	WIPER,AF1 1000	WINDSHIELD WIPER	AMP

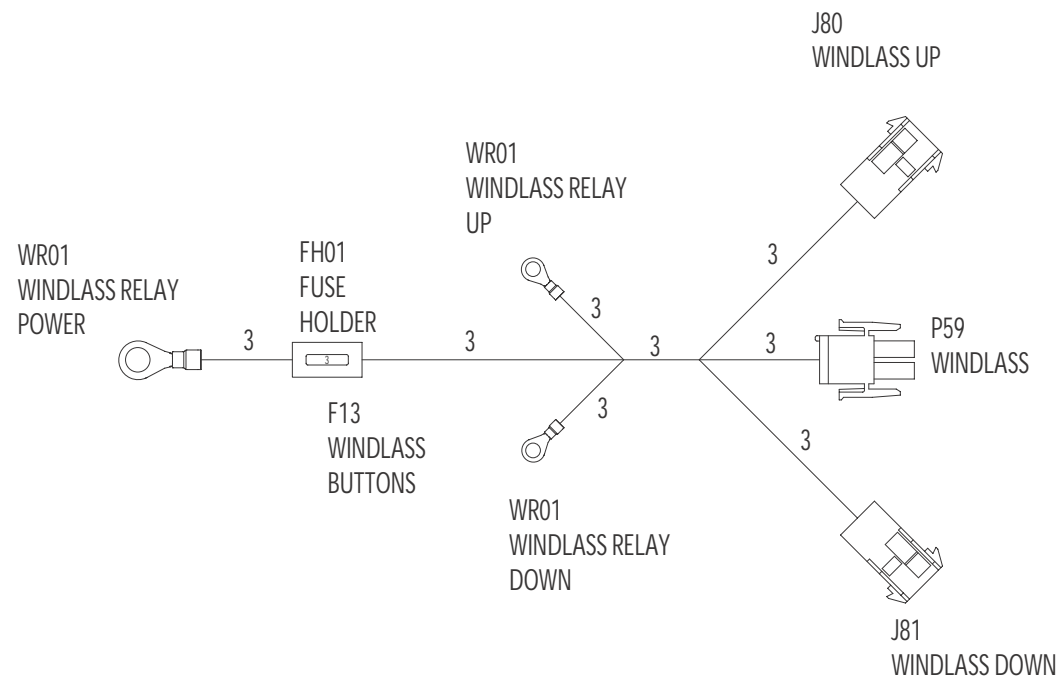

WR01 WINDLASS RELAY

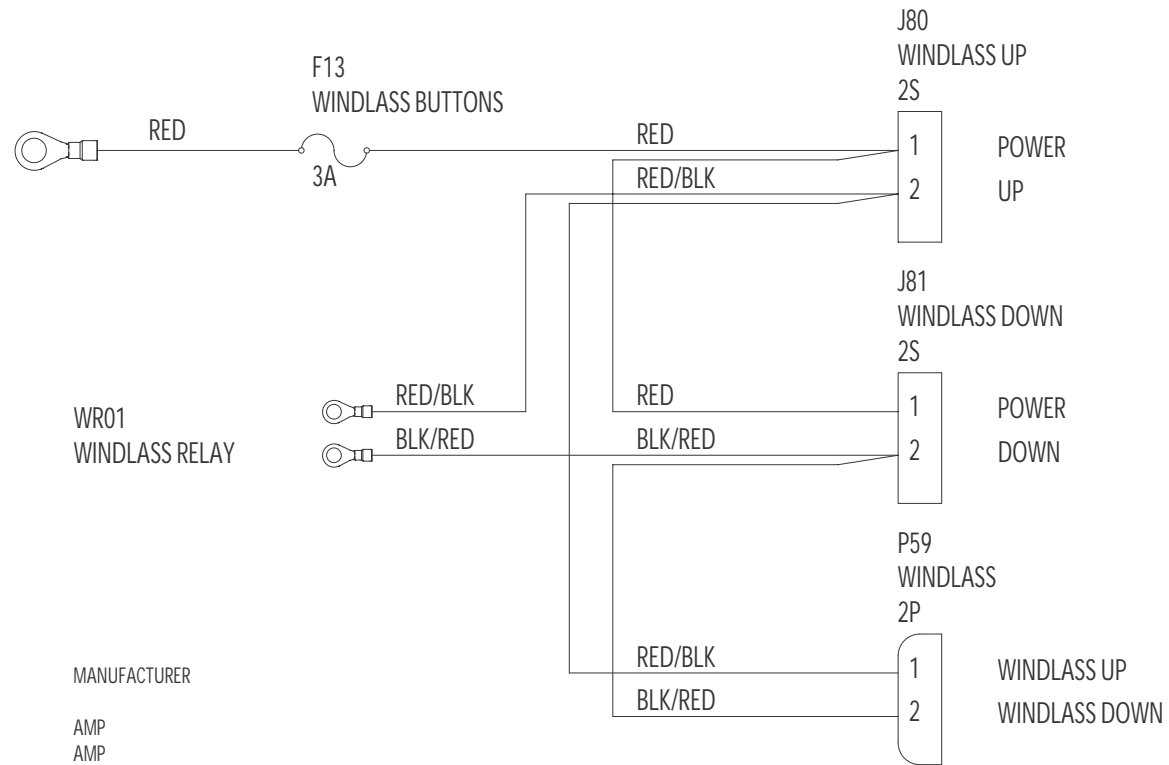

**FOUR WINNS PARTS LIST**

ITEM	PART NUMBER	QUANTITY	DESCRIPTION	FUNCTION	MANUFACTURER
	028-0189	2	TERM,RING,#8,16-14	08	AMP
	028-0193	1	TERM,RING,3/8,.250	11	AMP
	028-0390	2	PIN,UMNL,18-14	41	AMP
	028-0454	4	SOCKET,UMNL,18-14	42	AMP
	028-0506	1	FUSE,ATC,3A		BUSS
F13		1	FUSE HOLDER,INLINE		3M
FH01	028-0441	1	RECEPT,UMNL,2 CKT		AMP
J80	028-0441	1	RECEPT,UMNL,2 CKT		AMP
J81	028-0447	1	PLUG,UMNL,2 CKT		AMP
P59	065-0842-02	REF	WINDLASS RELAY		
WR01					

**FOUR WINNS WIRE LIST**

COLOR	GA	FIRST	PIN	TERM	NOTE	SECOND	PIN	TERM	NOTE	FUNCTION
RED	16	WR01	+	11		FH01	LINE	51		BUTTON POWER
RED	16	FH01	LOAD	51		J80	1	42	SA	BUTTON POWER
RED	16	J80	1	42	SA	J81	1	42		BUTTON POWER
RED/BLK	16	WR01	UP	08		J80	2	42	SB	WINDLASS UP
RED/BLK	16	J80	2	42	SB	P59	1	41		WINDLASS UP
BLK/RED	16	WR01	DOWN	08		J81	2	42	SC	WINDLASS DOWN
BLK/RED	16	J81	2	42	SC	P59	2	41		WINDLASS DOWN

FP01 FOOT PEDAL

P81 WINDLASS PEDAL 2P

RET POWER

BLK/RED

RED

**FOUR WINNS PARTS LIST**

ITEM	PART NUMBER	QUANTITY	DESCRIPTION	FUNCTION	MANUFACTURER
	028-0193	2	TERM,RING,3/8,16-14	11	AMP
	028-0390	2	PIN,UMNL,18-14	41	AMP
FP01		REF	FOOT PEDAL,MAXWELL		
P81	028-0447	1	PLUG,UMNL,2 CKT		AMP

**FOUR WINNS WIRE LIST**

COLOR	GA	FIRST	PIN	TERM	NOTE	SECOND	PIN	TERM	NOTE	FUNCTION
BLK/RED	16	FP01	-	10	BA	P81	1	41		WINDLASS PEDAL RET
RED	16	FP01	+	10	BA	P81	2	41		WINDLASS PEDAL POWER

**MAXWELL WINDLASS RELAY & FOOT PEDAL HARNESS ASSEMBLY**

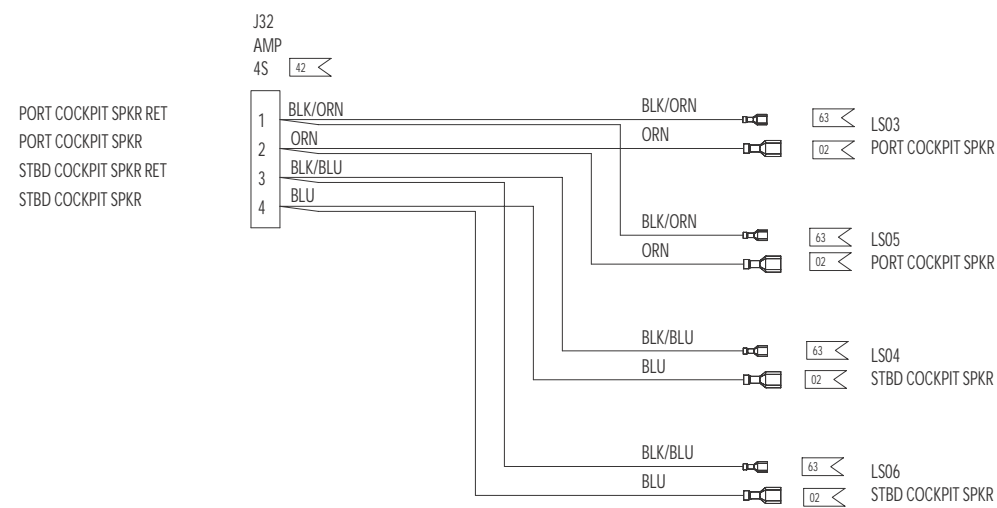
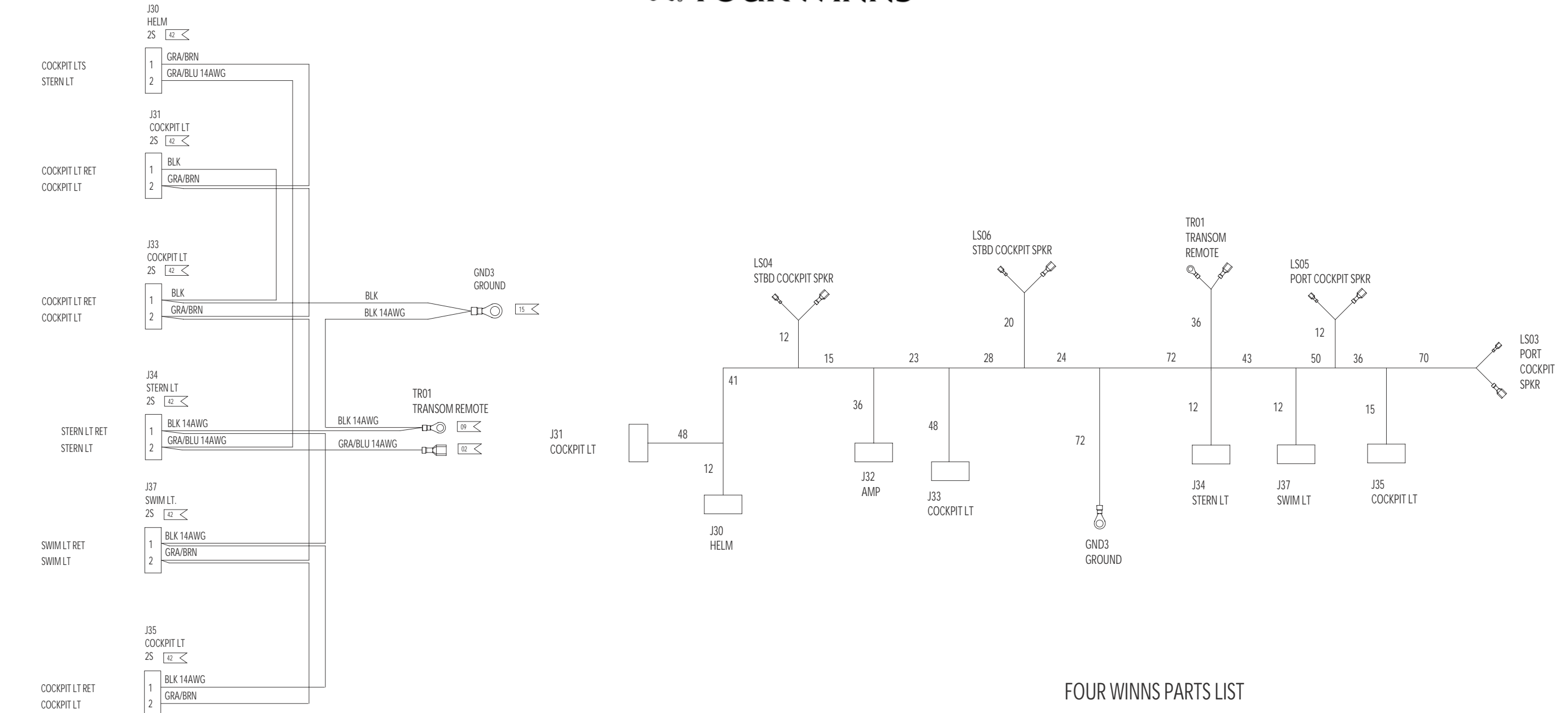

**FOUR WINNS PARTS LIST**

ITEM	PART NUMBER	QUANTITY	DESCRIPTION	FUNCTION	MANUFACTURER
-	028-0177	5	TERM,FASTON,250,16-14	02	AMP
-	028-0191	1	TERM,RING,#10,16-14	09	AMP
-	028-0193	1	TERM,RING,3/8,16-14	11	AMP
-	028-0454	16	SOCKET,UMNL,18-14	42	AMP
-	028-1288	4	TERM,FASTON,205,18-14	63	-
GND3	-	REF	DC GROUND	DC RET	-
J30	028-0441	1	RECEPT,UMNL,2 CKT	HELM	AMP
J31	028-0441	1	RECEPT,UMNL,2 CKT	COCKPIT LT	AMP
J32	028-0442	1	RECEPT,UMNL,4 CKT	AMP	AMP
J33	028-0441	1	RECEPT,UMNL,2 CKT	COCKPIT LT	AMP
J34	028-0441	1	RECEPT,UMNL,2 CKT	STERN LT	AMP
J35	028-0441	1	RECEPT,UMNL,2 CKT	COCKPIT LT	AMP
J37	028-0441	1	RECEPT,UMNL,2 CKT	SWIM LT	AMP
LS03	-	REF	SPEAKER	SPEAKER	-
LS04	-	REF	SPEAKER	SPEAKER	-
LS05	-	REF	SPEAKER	SPEAKER	-
LS06	-	REF	SPEAKER	SPEAKER	-

**280 HORIZON  
COCKPIT - DECK  
HARNESS ASSEMBLY**

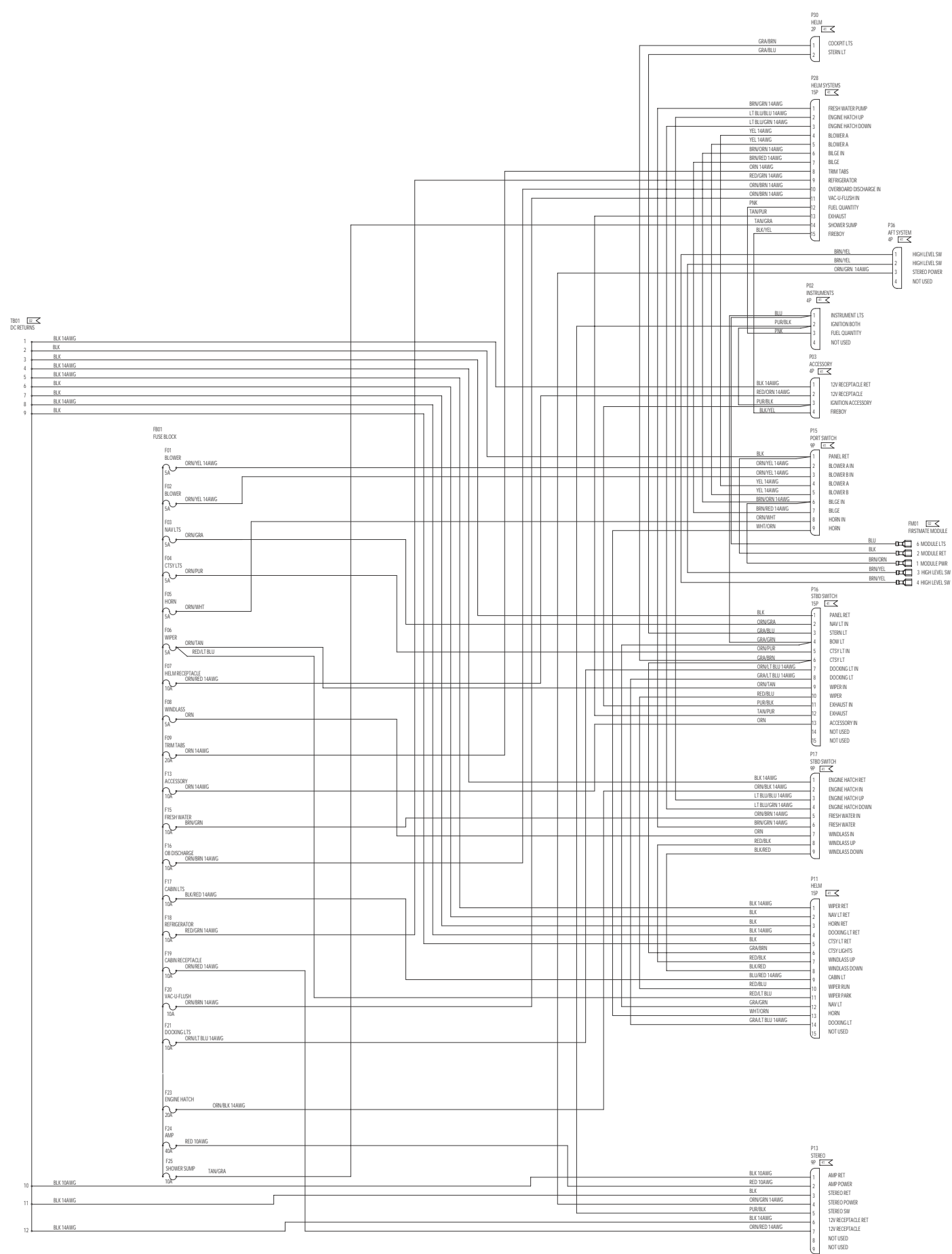

### FOUR WINNS PARTS LIST

ITEM	PART NUMBER	QUANTITY	DESCRIPTION	FUNCTION	MANUFACTURER
	028-0177	35	TERM FASTON, 250,16-14	02	AMP
	028-0179	2	TERM FASTON, 250,12-10	07	AMP
	028-0453	2	PIN LUM/NL 12-10	40	AMP
	028-0390	77	PIN LUM/NL 18-14	41	AMP
F01	028-0507	1	FUSE ATC 5A	BLOWER	BUSS
F02	028-0507	1	FUSE ATC 5A	BLOWER	BUSS
F03	028-0507	1	FUSE ATC 5A	NAV/LTS	BUSS
F04	028-0507	1	FUSE ATC 5A	NAV/LTS	BUSS
F05	028-0507	1	FUSE ATC 5A	CTS/LTS	BUSS
F06	028-0507	1	FUSE ATC 5A	HORN	BUSS
F07	028-0507	1	FUSE ATC 5A	WIPER	BUSS
F08	028-0509	1	FUSE ATC 10A	HELM RECEPT	BUSS
F09	028-0507	1	FUSE ATC 5A	WINDLASS	BUSS
F13	028-0511	1	FUSE ATC 20A	TRIM TABS	BUSS
F15	028-0509	1	FUSE ATC 10A	ACCESSORY	BUSS
F16	028-0509	1	FUSE ATC 10A	FRESH WATER	BUSS
F17	028-0509	1	FUSE ATC 10A	OB DISCHARGE	BUSS
F18	028-0509	1	FUSE ATC 10A	CABIN/LTS	BUSS
F20	028-0509	1	FUSE ATC 10A	VAC-U-FLUSH	BUSS
F21	028-0509	1	FUSE ATC 10A	DOCKING/LTS	BUSS
F22	028-0511	1	FUSE ATC 20A	ENGINE HATCH	BUSS
F23	028-1770	1	FUSE ATC 40A	AMP	BUSS
F24	028-0509	1	FUSE ATC 10A	SHOWER SLUMP	BUSS
F801	028-0505	1	FUSE BLOCK 28 POS	HELM FUSE BLOCK	GENERAL
P02	028-0448	1	PLUG LUM/NL 4 CKT	INSTRUMENTS	AMP
P03	028-0448	1	PLUG LUM/NL 4 CKT	ACCESSORY	AMP
P11	028-0452	1	PLUG LUM/NL 15 CKT	HELM	AMP
P13	028-0449	1	PLUG LUM/NL 9 CKT	STEREO	AMP
P15	028-0449	1	PLUG LUM/NL 9 CKT	PORT SWITCH	AMP
P16	028-0452	1	PLUG LUM/NL 15 CKT	STBD SWITCH	AMP
P17	028-0449	1	PLUG LUM/NL 9 CKT	STBD SWITCH	AMP
P28	028-0452	1	PLUG LUM/NL 15 CKT	HELM SYSTEMS	AMP
P30	028-0447	1	PLUG LUM/NL 2 CKT	HELM	AMP
P36	028-0448	1	PLUG LUM/NL 4 CKT	AFT SYSTEM	AMP
TB01		REF	DC HELM RET	HELM RET	GENERAL
FM01		REF	FIRSTMATE MODULE	FIRSTMATE CONTROL	

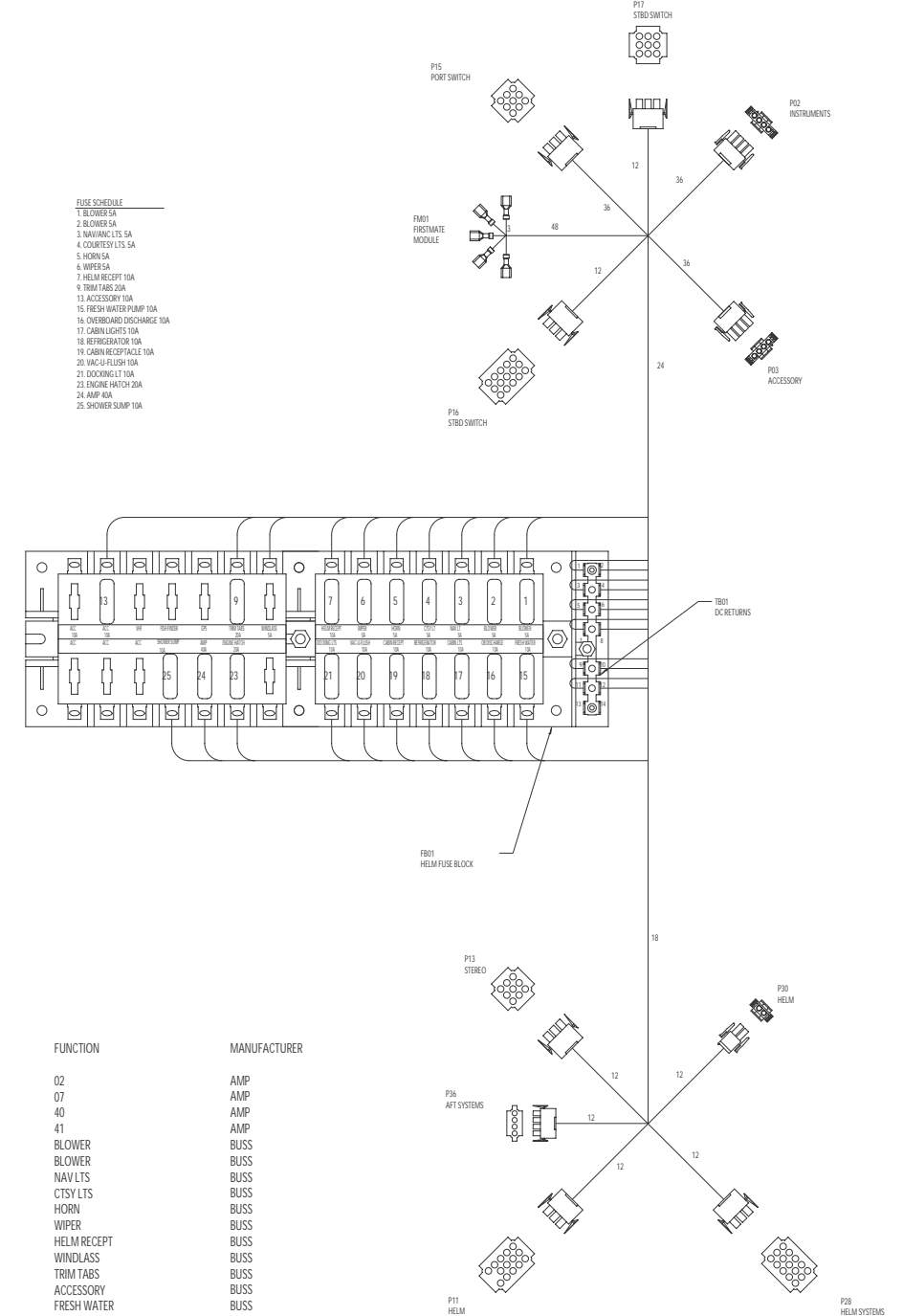



**FOUR WINNS PARTS LIST**

ITEM	PART NUMBER	QUANTITY	DESCRIPTION	FUNCTION	MANUFACTURER
-	028-0177	1	TERM.FASTON .250,18-14	02	AMP
-	028-0201	1	TERM.TAB,FASTON .250,18-14	04	AMP
-	028-0191	1	TERM.RINGS,#10,16-14	09	AMP
-	028-0197	2	TERM.RINGS,3/8,16-14	11	AMP
-	028-0198	3	TERM.RINGS,#10,8	17	AMP
-	028-0356	1	TERM.RING,#6,16-14	22	AMP
-	028-0315	1	TERM.RING,1/4,8	24	AMP
-	028-0316	1	TERM.RING,3/8,8	25	AMP
-	028-0454	55	SOCKET,UMNL,18-14	42	AMP
-	028-0159	4	SOCKET,CMNL,20-14	45	AMP
CB30	-	REF	BREAKER,40A,MP	-	-
CB32	-	REF	BREAKER,5A	-	-
DS01	027-2199	1	HARNESS ASSEMBLY 25' TRANSDUCER	DEPTH SOUNDER CABLE	FARIA/TALON
FB01	-	REF	FUSE BLOCK,28 POSITION	HELM FUSE BLOCK	-
FS01	-	REF	SENDER, FUEL STUART WARNER	FUEL SENDER	-
GND1	-	REF	DC GROUND	FUSEBLOCK,DC RET	-
GND2	-	REF	DC GROUND	DC RET	-
GND3	-	REF	DC GROUND	DC RET	-
HS01	024-0073	1	HOSE,SPEEDOMETER,OMC	SPEEDOMETER HOSE	OMC
J13	028-0441	1	RECEPT,UMNL,2 CKT	REFRIGERATOR	-
J14	028-0442	1	RECEPT,UMNL,4 CKT	VAC U FLUSH	AMP
J15	028-0441	1	RECEPT,UMNL,2 CKT	OVERBOARD DISCHARGE	AMP
J16	028-0441	1	RECEPT,UMNL,2 CKT	BLOWER A	AMP
J17	028-0441	1	RECEPT,UMNL,2 CKT	BLOWER B	AMP
J18	028-0443	1	RECEPT,UMNL,9 CKT	FLUSH,PANEL	AMP
J19	028-0442	1	RECEPT,UMNL,4 CKT	BILGE PUMP	AMP
J20	028-0441	1	RECEPT,UMNL,2 CKT	ENGINE HATCH	AMP
J21	028-0442	1	RECEPT,UMNL,2 CKT	HELM SYSTEMS	AMP
J22	028-0441	1	RECEPT,UMNL,2 CKT	FRESH WATER PUMP	AMP
J24	028-0441	1	RECEPT,UMNL,2 CKT	BATTERY SWITCH	AMP
J27	028-0441	1	RECEPT,UMNL,2 CKT	FUEL FILL	AMP
J28	028-0446	1	RECEPT,UMNL,15 CKT	HELM SYSTEMS	AMP
J29	028-0441	1	RECEPT,UMNL,2 CKT	SHOWER SUMP BOX	AMP
J30	028-0443	1	RECEPT,UMNL,9 CKT	TRIM TABS	AMP
J31	028-0441	1	RECEPT,UMNL,2 CKT	FIRE BOY	AMP
J32	028-0441	1	RECEPT,UMNL,2 CKT	HIGH LEVEL SW	AMP
J32	028-0441	1	RECEPT,UMNL,2 CKT	TRIM TABS	AMP
P22	028-0204	1	PLUG,CMNL,4 CKT	HELM DC RET	AMP
TB01	-	REF	TERMINAL BLOCK,14POS	TRIM TAB PUMP	-
TT01	-	REF	TRIM TAB PUMP	-	-

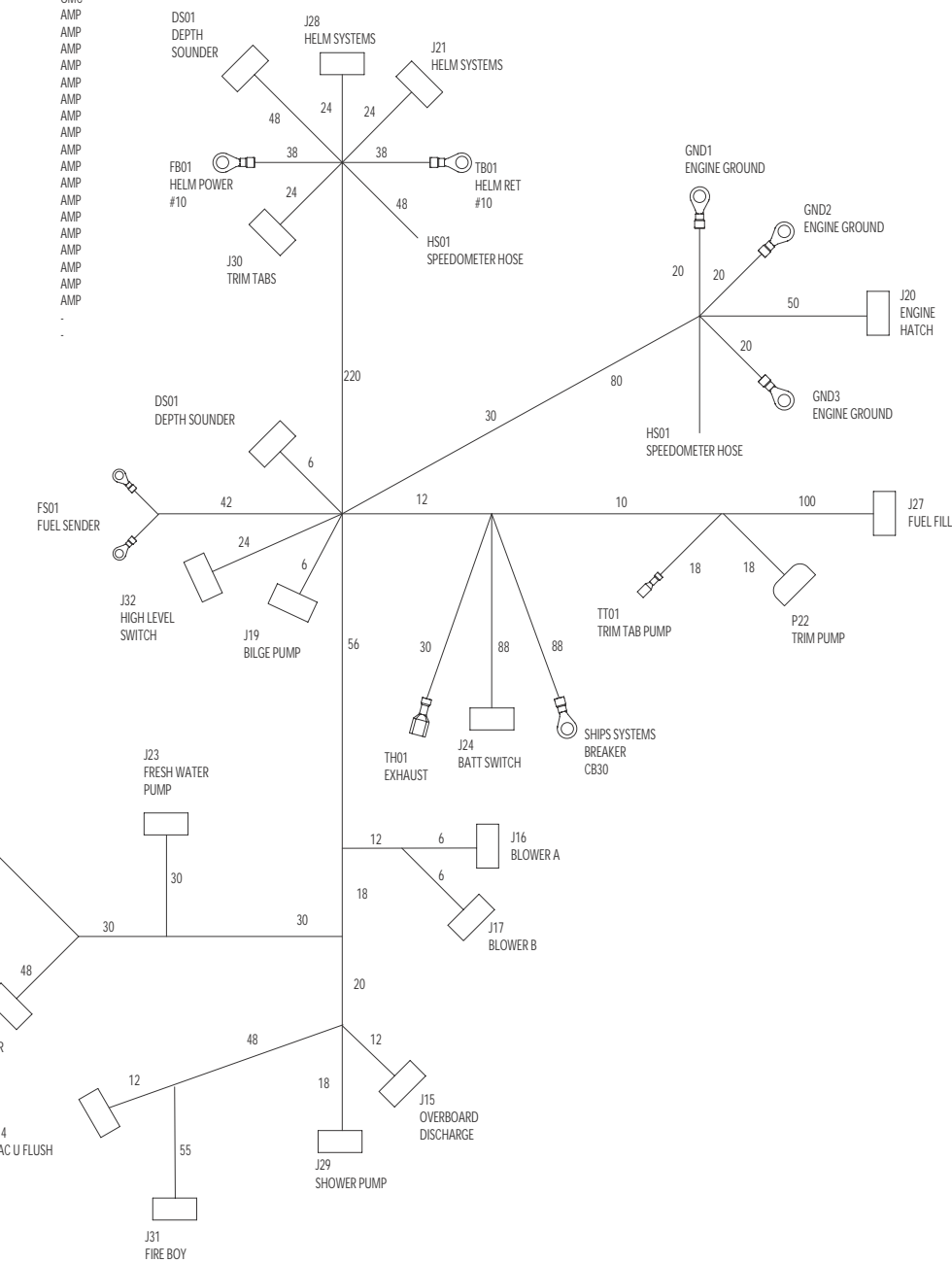
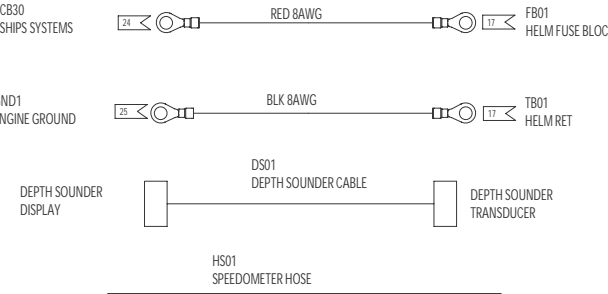
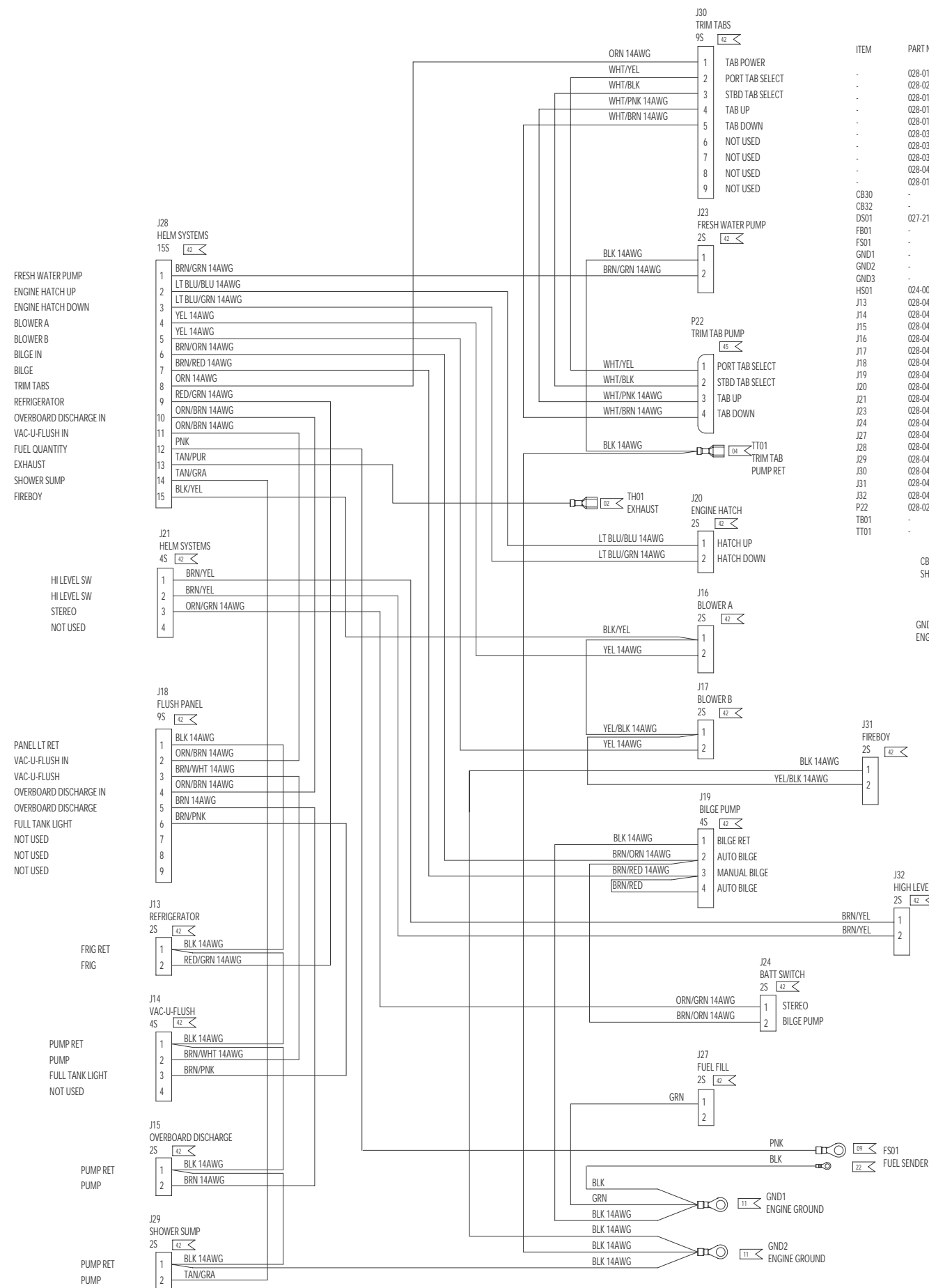

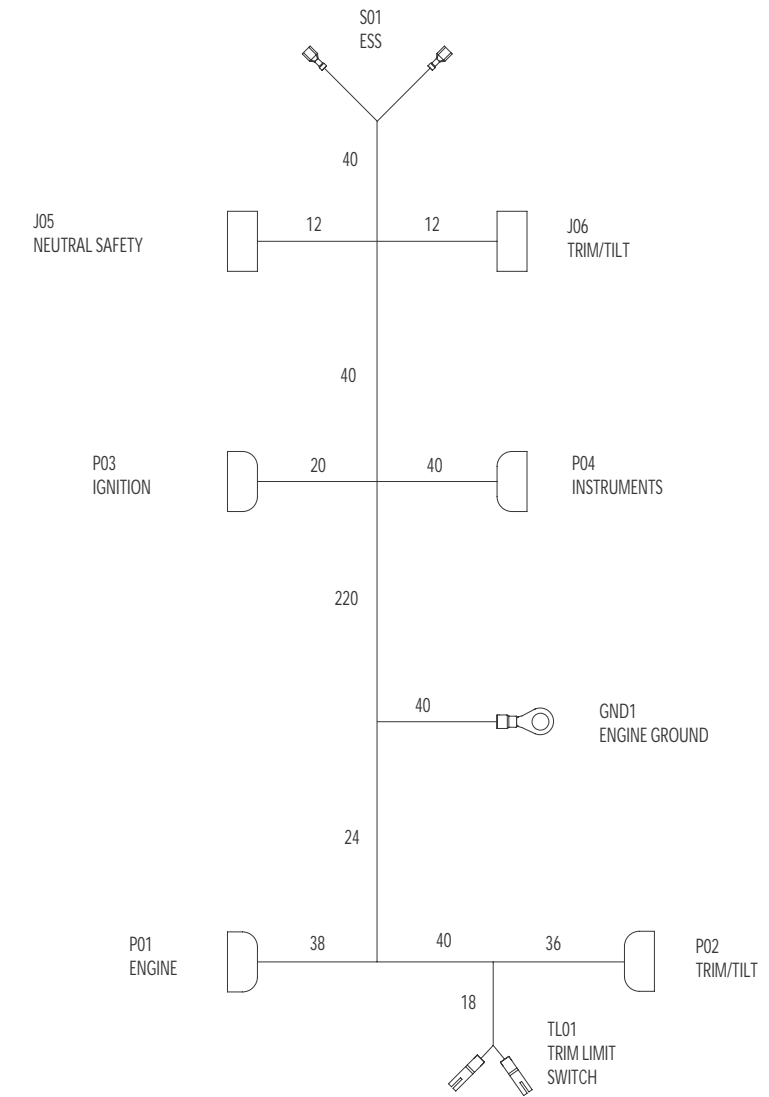
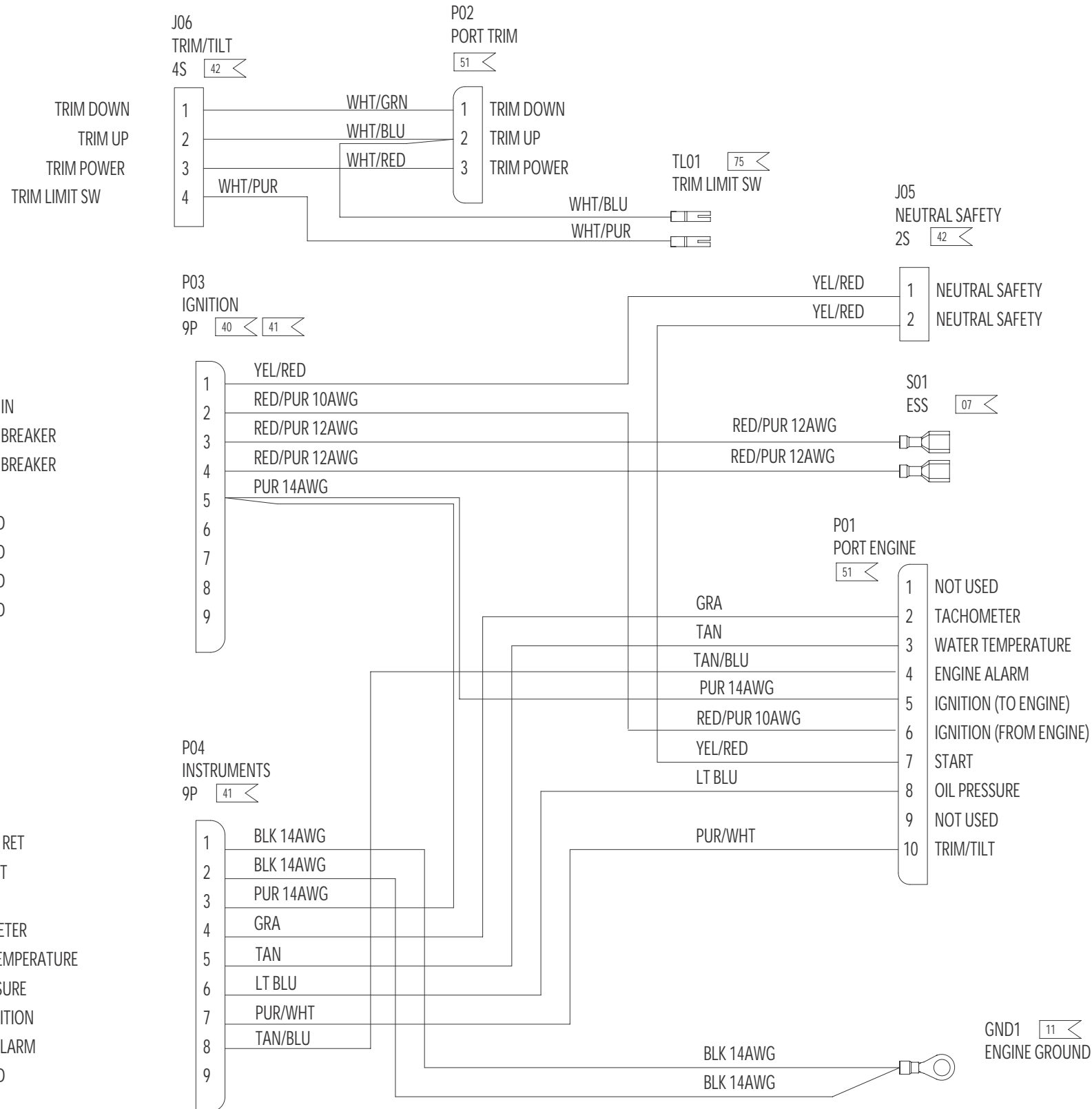

**FOUR WINNS PARTS LIST**

ITEM	PART NUMBER	QUANTITY	DESCRIPTION	FUNCTION	MANUFACTURER
-	028-0179	2	TERM,FASTON,250,12-10	07	AMP
-	028-0197	1	TERM,RING,3/8,16-14	11	AMP
-	028-0453	3	PIN,UMNL,12-10	40	AMP
-	028-0390	10	PIN,UMNL,18-14	41	AMP
-	028-0454	6	SOCKET,UMNL,18-14	42	AMP
-	-	11	VENDER TERMINATED	51	AMP
-	028-1823	2	TERM,BULLET,FEM,INS.,156,16-14	75	AMP
J05	028-0441	1	RECEPT,UMNL,2 CKT	NEUTRAL SAFETY	AMP
J06	028-0442	1	RECEPT,UMNL,4 CKT	TRIM/TILT	OMC
P01	-	1	PLUG,ENGINE IO	ENGINE	OMC
P02	-	1	PLUG,TRIM/TILT	TRIM/TILT	AMP
P03	028-0449	1	PLUG,UMNL,9 CKT	IGNITION	AMP
P04	028-0449	1	PLUG,UMNL,9 CKT	INSTRUMENTS	-
S01	-	REF	SWTICH,ESS,NO	ESS	-
TL01	-	REF	TRIM LIMIT	TRIM LIMIT SWITCH	-

**280 HORIZON  
ENGINE SYSTEM  
HARNESS ASSEMBLY**

025-2435

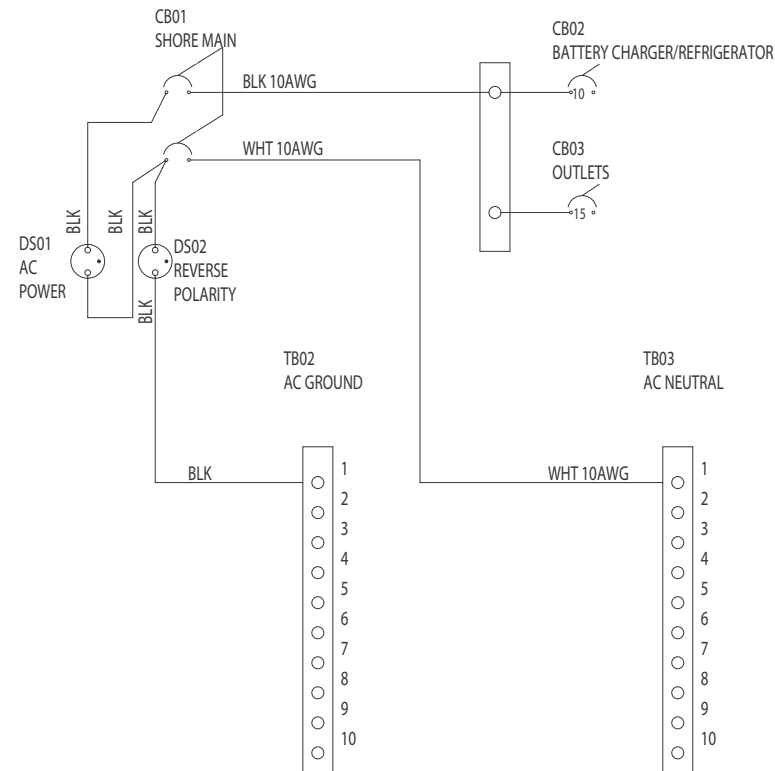
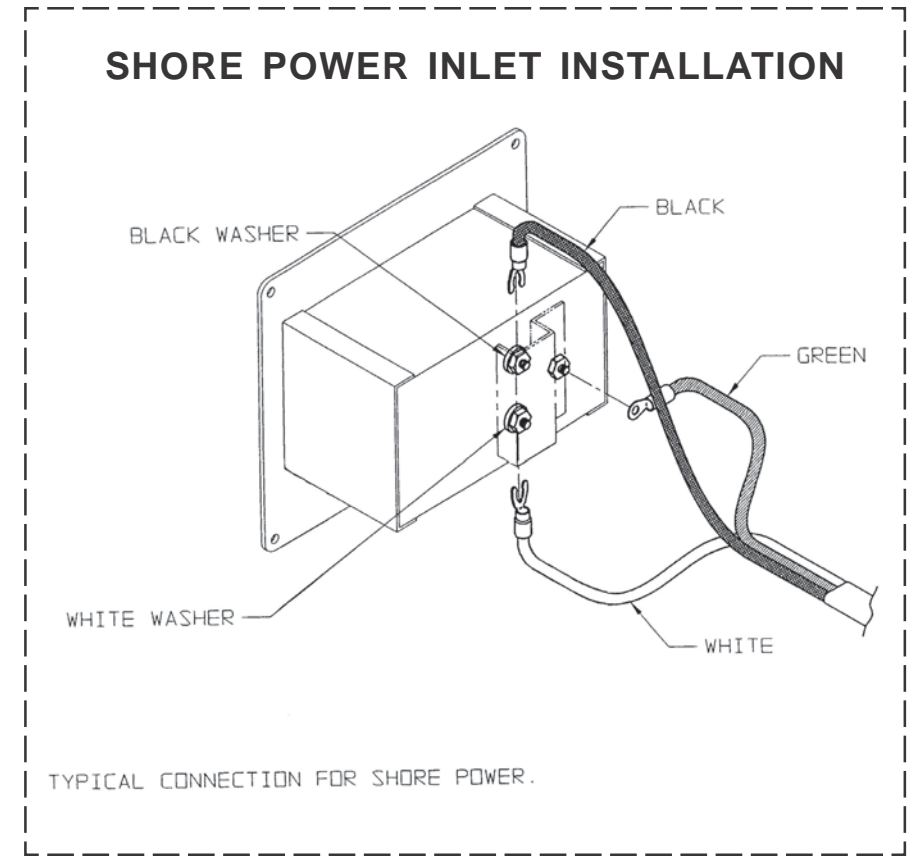
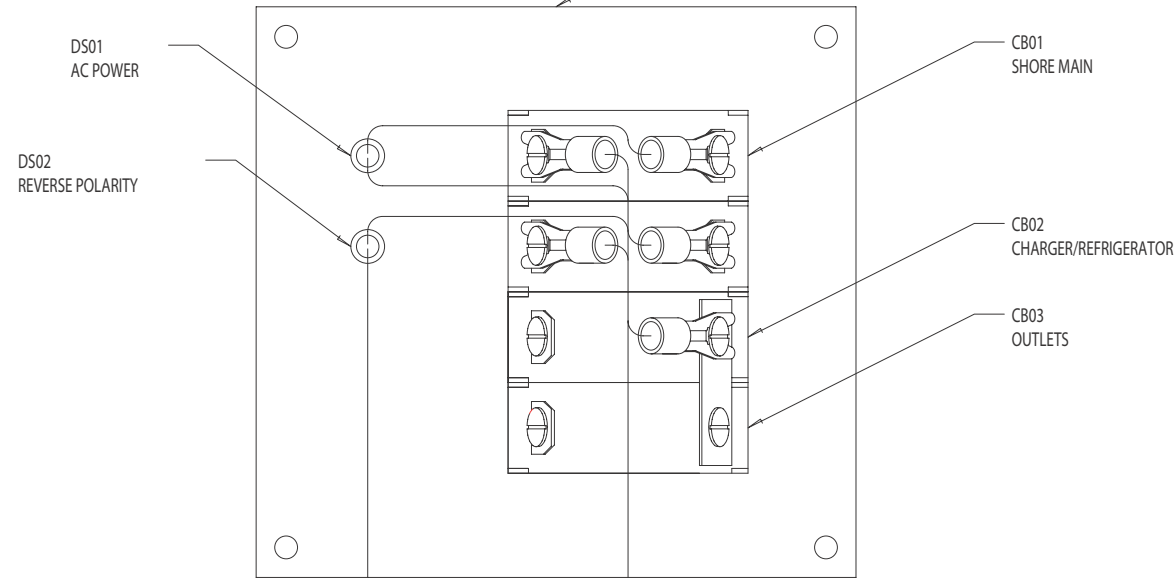
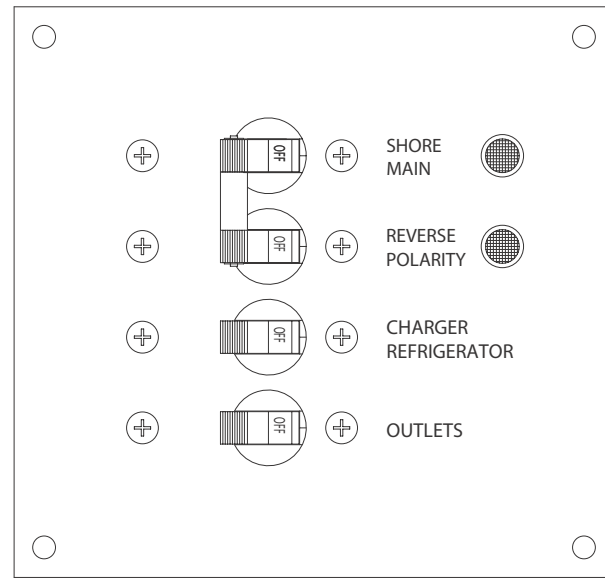

12 7

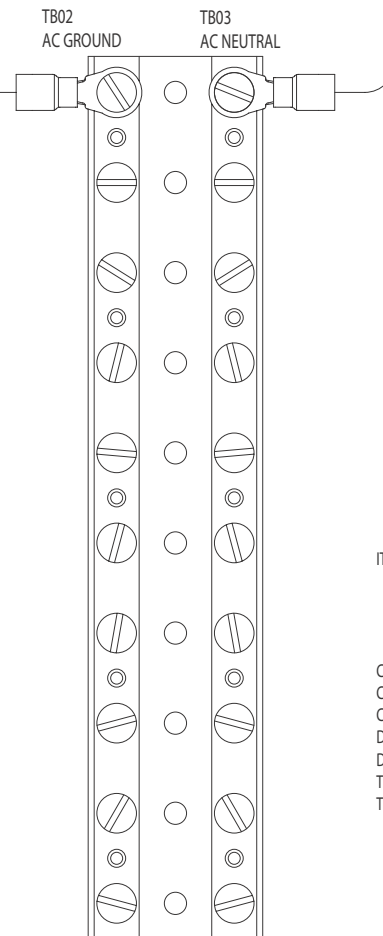

**FOUR WINNS WIRE LIST**

COLOR	GA	FIRST	PIN	TERM	NOTE	SECOND	PIN	TERM	NOTE	FUNCTION
BLK	16	CB01	LINE A	09		DS01	+	51		AC POWER NEON +
BLK	16	CB01	LINE B	09	SA	DS01	-	51		AC POWER NEON -
BLK	16	CB01	LINE B	09	SA	DS02	+	51		AC REV POL NEON +
BLK	16	TB02	1	09		DS02	-	51		AC REV POL NEON -
BLK	10	CB01	LOAD A	13		CB02	LINE	13		AC HOT LINE
WHT	10	CB01	LOAD B	13		TB03	1	13		AC NEUTRAL LINE

**FOUR WINNS PARTS LIST**

ITEM	PART NUMBER	QUANTITY	DESCRIPTION	FUNCTION	MANUFACTURER
	028-0191	3	TERM,RING,#10,16-14	09	AMP
	028-0195	4	TERM,RING,#10,12-10	13	AMP
	025-2435	1	PANEL,BLANK,AC CABIN	BLANK PANEL	
CB01	028-0484	1	BREAKER,30A DP	SHORE MAIN	CARL SW
CB02	028-0416	1	BREAKER,10A	REFRIGERATOR/CHARGER	CARL SW
CB03	028-0417	1	BREAKER,15A	OUTLETS	CARL SW
DS01	028-0531	1	NEON,250V GREEN	AC POWER	SOLICO
DS02	028-0530	1	NEON,250V RED	AC REV POL	SOLICO
TB02	028-0302	1	BUSS BAR,10 GANG	AC GROUND	WESGARDE
TB03	028-0302	1	BUSS BAR,10 GANG	AC NEUTRAL	WESGARDE

**280 HORIZON  
AC CABIN  
PANEL ASSEMBLY**

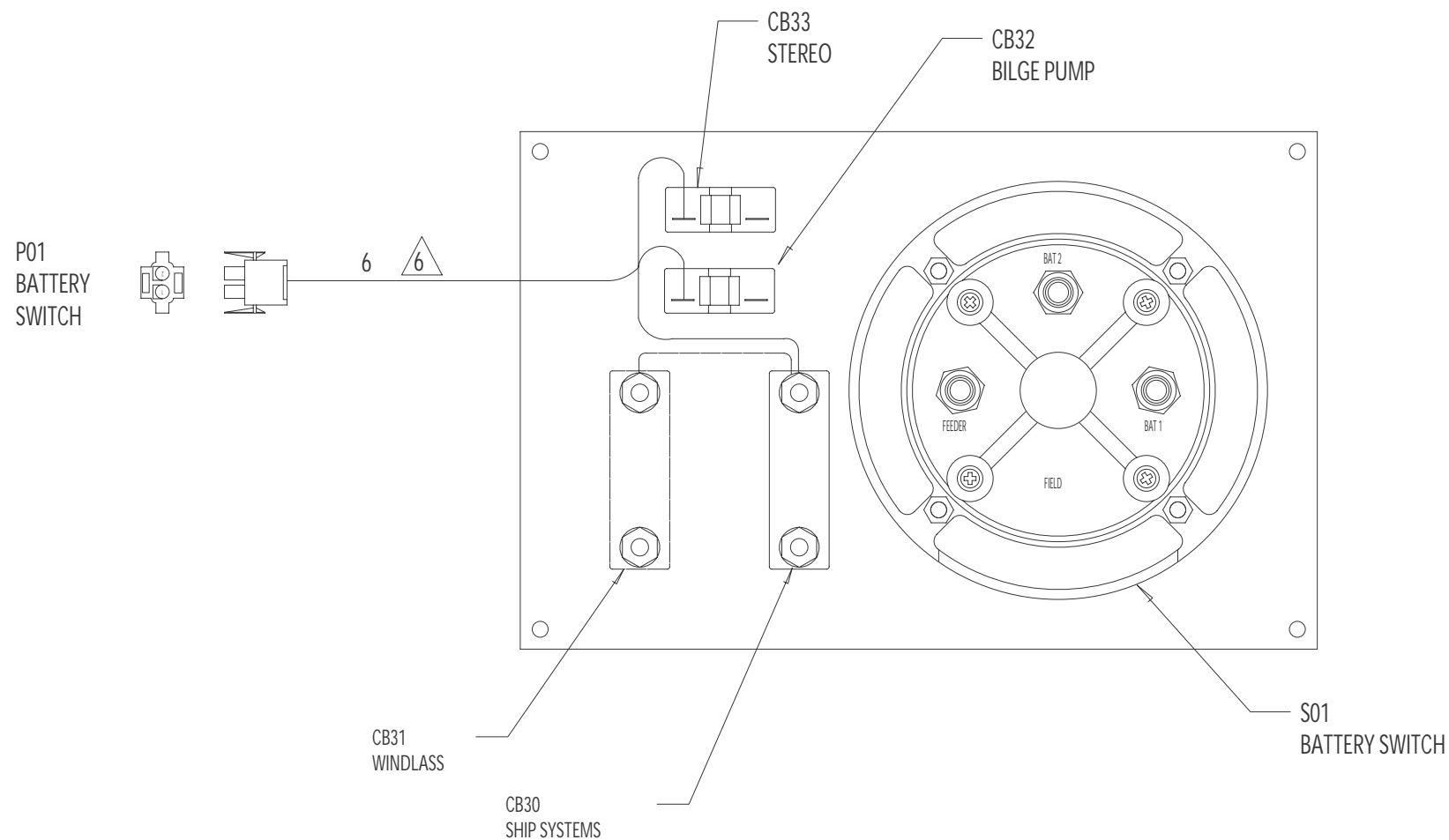
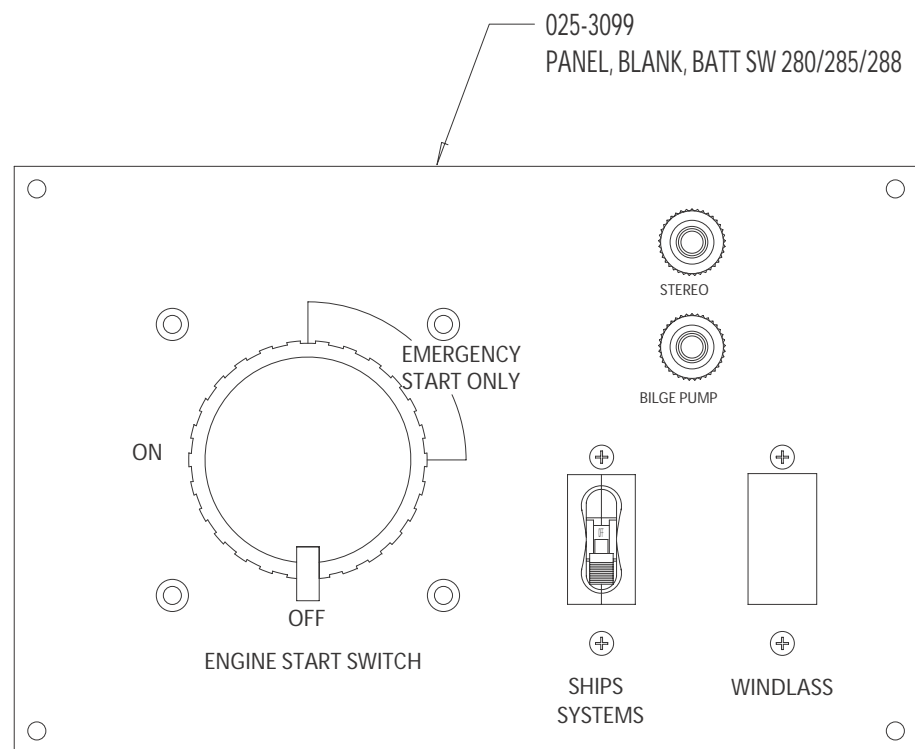

**BATTERY SWITCH MOUNTING DETAIL**

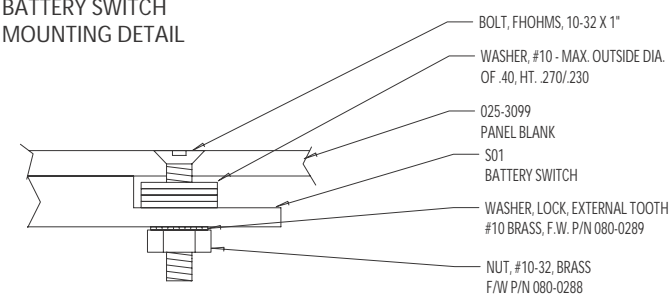

**FOUR WINNS PARTS LIST**

ITEM	PART NUMBER	QUANTITY	DESCRIPTION	FUNCTION	MANUFACTURER
-	028-0177	2	TERM,FASTON,.250,18-14	02	AMP
-	028-0192	1	TERM,RING,1/4,16-14	10	AMP
-	028-0399	1	TERM,RING,3/8,2	18	AMP
-	-	1	TERM,RING,1/4,2	31	AMP
-	-	1	TERM,RING,1/4,4	35	AMP
-	028-0390	2	PIN,UMNL,18-14	41	AMP
-	025-3099	1	PANEL,BLANK,BATTERY SWITCH	-	-
P01	028-0447	1	PLUG,UMNL,2 CKT	BATTERY SWITCH	AMP
CB30	028-1888	1	BREAKER,80A	SHIPS SYSTEMS	CARL SW
CB31	028-1888	REF	BREAKER,80A	WINDLASS	CARL SW
CB32	028-1880	1	BREAKER,10A	BILGE	ETA
CB33	028-1881	1	BREAKER,20A	STEREO	ETA
S01	028-0485	1	SWITCH, DUAL BATTERY	BATT SWITCH	GUEST

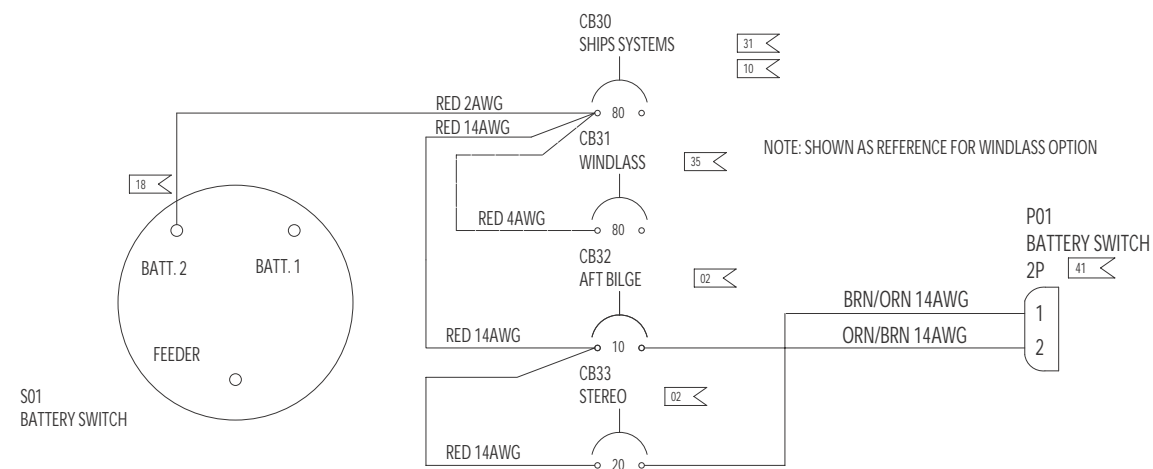

**280 HORIZON BATTERY SWITCH PANEL ASSEMBLY**

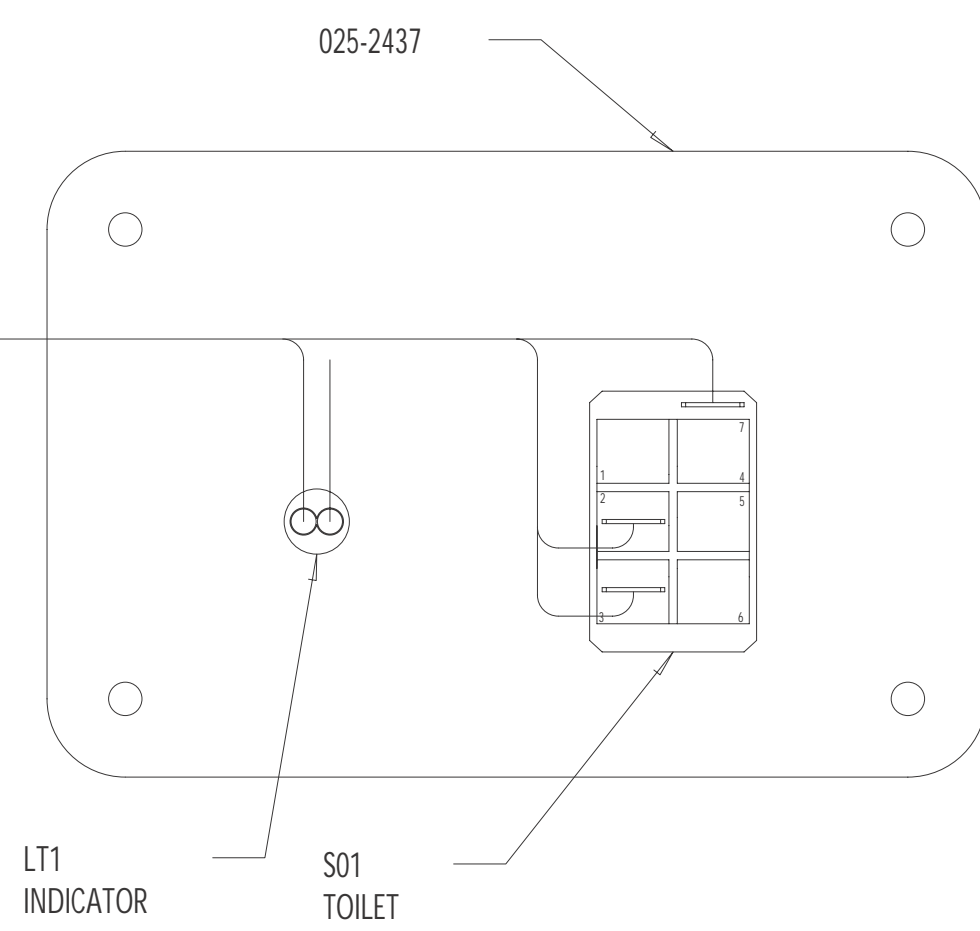
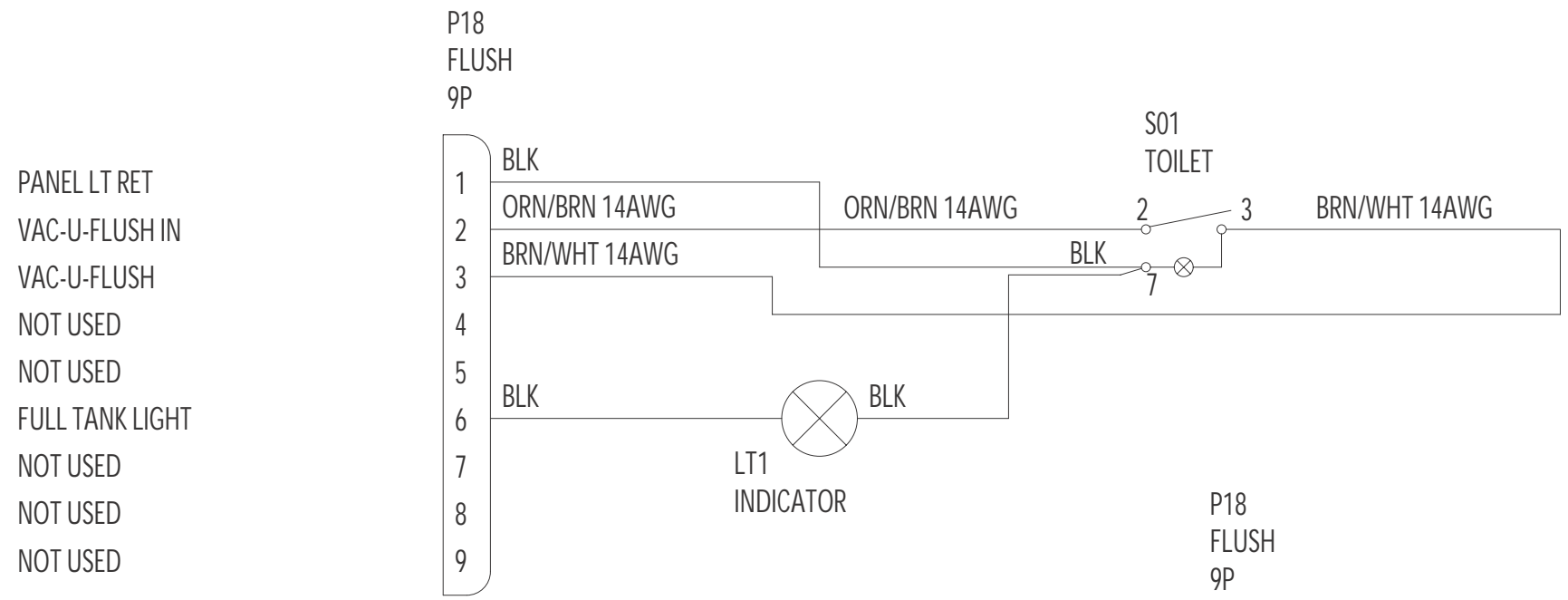

**FOUR WINNS PARTS LIST**

ITEM	PART NUMBER	QUANTITY	DESCRIPTION	FUNCTION	MANUFACTURER
	028-0177	3	RECEPT,FASTON,250,18-14	02	AMP
	028-0390	4	PIN,UMNL,18-14	41	AMP
	025-2437	1	PANEL,BLANK,TOILET	BLANK	
J18	028-0449	1	PLUG,UMNL,9 CKT	FLUSH	AMP
LT1		1	INDICATOR, RED 12V	FULL LIGHT	SOLICO
S01	028-0457	1	SWITCH,SPST,CONT III	FLUSH	CARL SW

**FOUR WINNS WIRE LIST**

COLOR	GA	FIRST	PIN	TERM	NOTE	SECOND	PIN	TERM	NOTE	FUNCTION
BLK	16	P18	1	41		S01	7	02	SA	SWITCH LT RET
ORN/BRN	14	P18	2	41		S01	2	02		VAC-U-FLUSH IN
BRN/WHT	14	P18	3	41		S01	3	02		VAC-U-FLUSH
BLK	16	LT1	1	51		P18	6	41		FULL LIGHT
BLK	16	LT1	2	51		S01	7	02	SA	FULL LIGHT

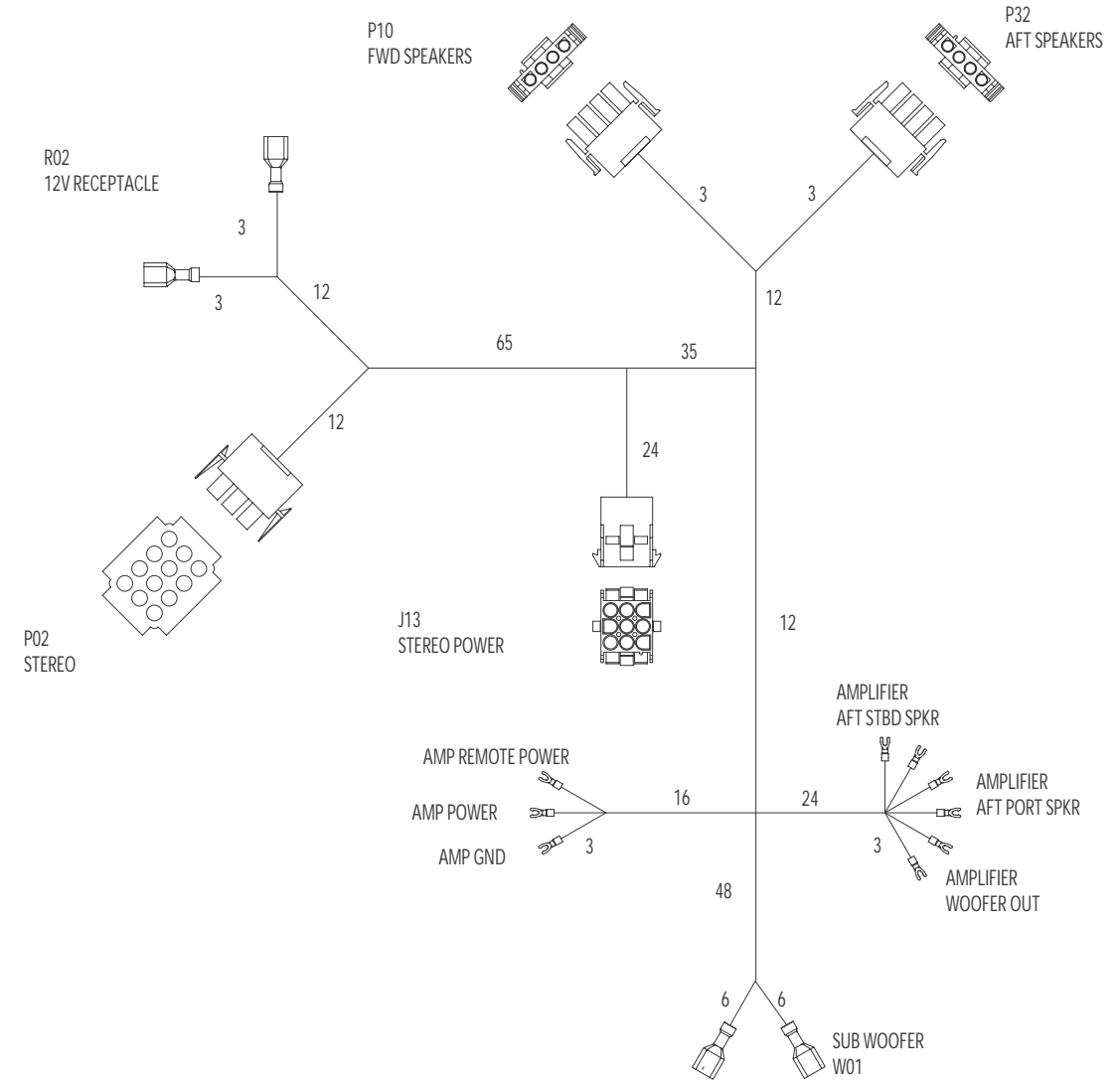
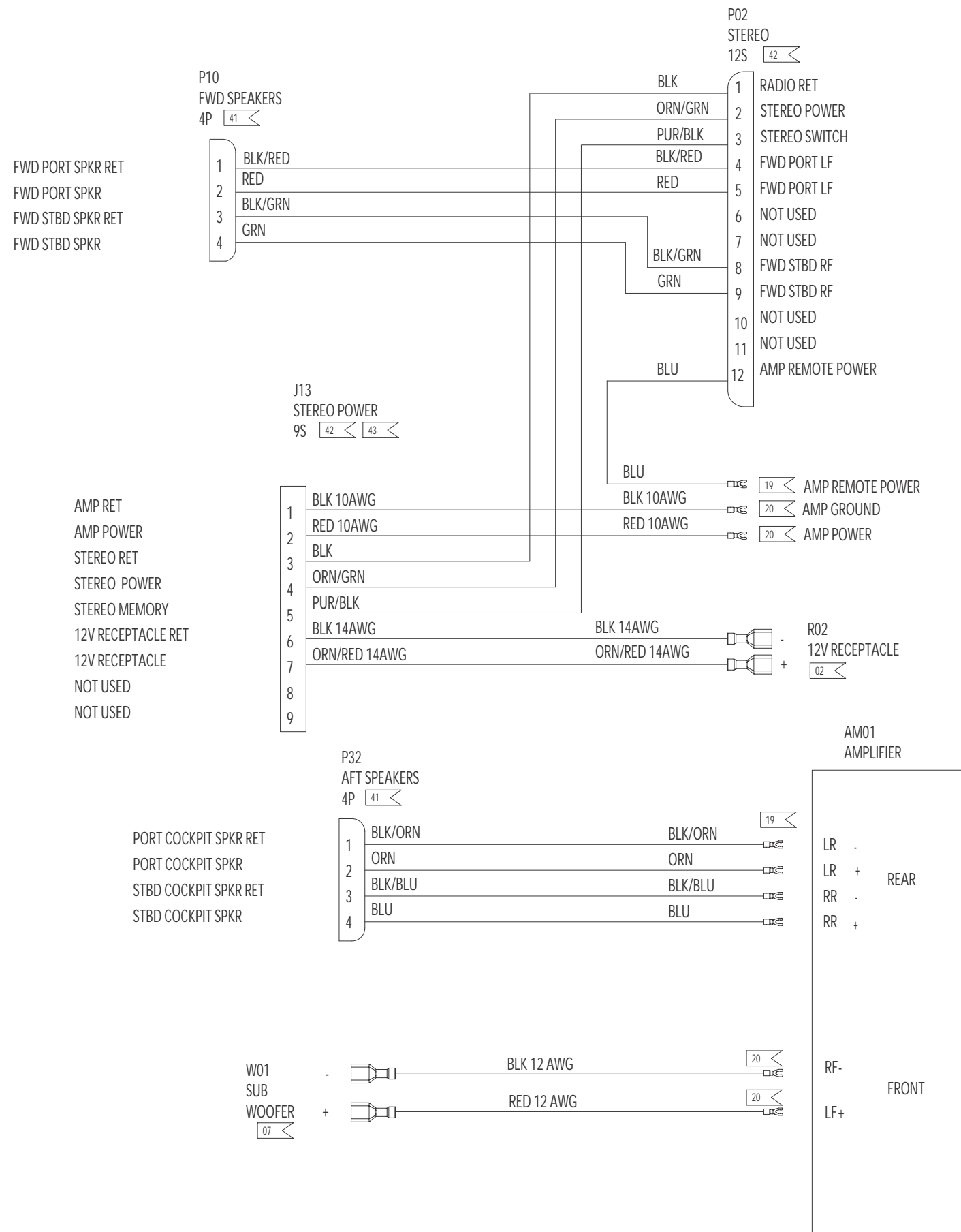

**FOUR WINNS PARTS LIST**

ITEM	PART NUMBER	QUANTITY	DESCRIPTION	FUNCTION	MANUFACTURER
-	028-0177	2	TERM,FASTON,250,18-14	02	AMP
-	028-0179	2	TERM,FASTON,250,12-10	07	AMP
-	028-0390	8	PIN,UMNL,18-14	41	AMP
-	028-0454	13	SOCKET,UMNL,18-14	42	AMP
-	028-0455	2	SOCKET,UMNL,12-10	43	AMP
-	028-0220	5	TERMINAL,SS,PG #8,16-14	19	AMP
-	028-0199	4	TERMINAL,SS,PG #8,12-10	20	AMP
AM01	-	REF	AMPLIFIER,SONY 754	AMPLIFIER	-
J13	028-0444	1	RECEPT,UMNL,9 CKT	STEREO POWER	AMP
P02	028-0451	1	PLUG,UMNL,12 CKT	STEREO	AMP
P10	028-0448	1	PLUG,UMNL,4 CKT	FWD SPEAKERS	AMP
P32	028-0448	1	PLUG,UMNL,4 CKT	AFT SPEAKERS	AMP
R02	028-1100	REF	RECECT,12V AFI	12V RECEPTACLE	-
W01	-	REF	SUB-WOOFER	BASS SPEAKERS	-

**280 HORIZON  
STEREO  
HARNESS ASSEMBLY**





RCA Outputs: Refer to specific source unit model for proper connection configuration.

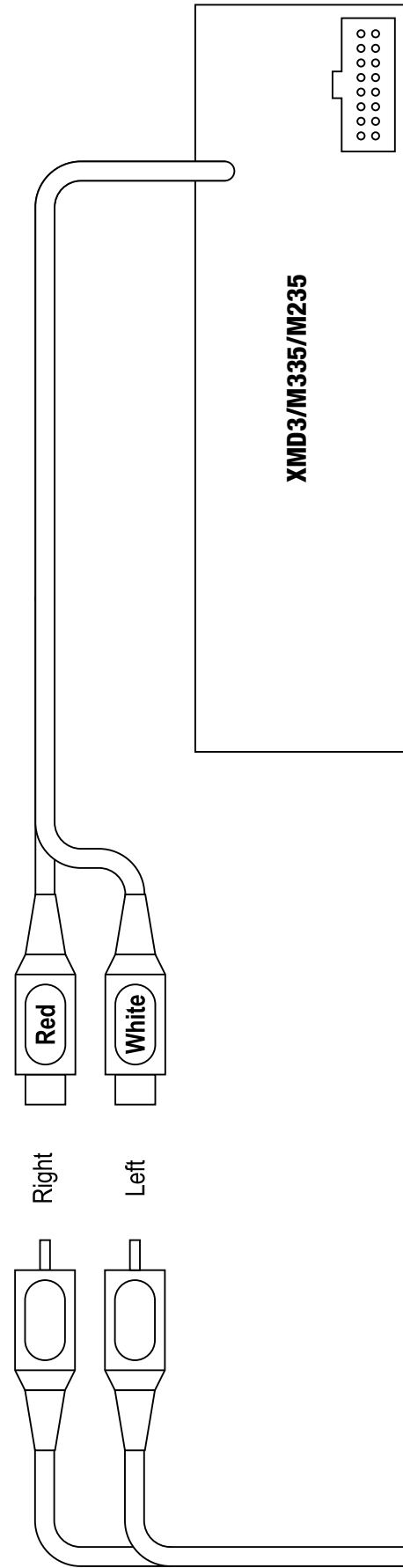

RCA Cables: Connect to Power Amplifier's CH1 & CH2 RCA Inputs

BASS EXTENDER: Adjust to desired level

CH3/4 GAIN: 2V (1 o'clock)

CH1/2 GAIN: 2V (1 o'clock)

SOURCE SELECT: 2CH/BASS

CH1/2: MONO

CH3/4: STEREO

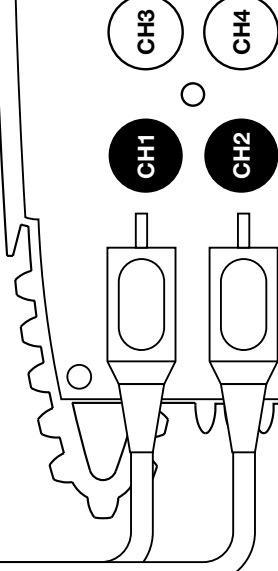

**APX480M**

CH1/2 FREQ: 100Hz (12 o'clock)

CH1/2 FILTER: LP

CH3/4 FILTER: HP

RANGE: X1 (Out)

CH3/4 FREQ: 100Hz (12 o'clock)

Remote Turn-On: (Blue/White)

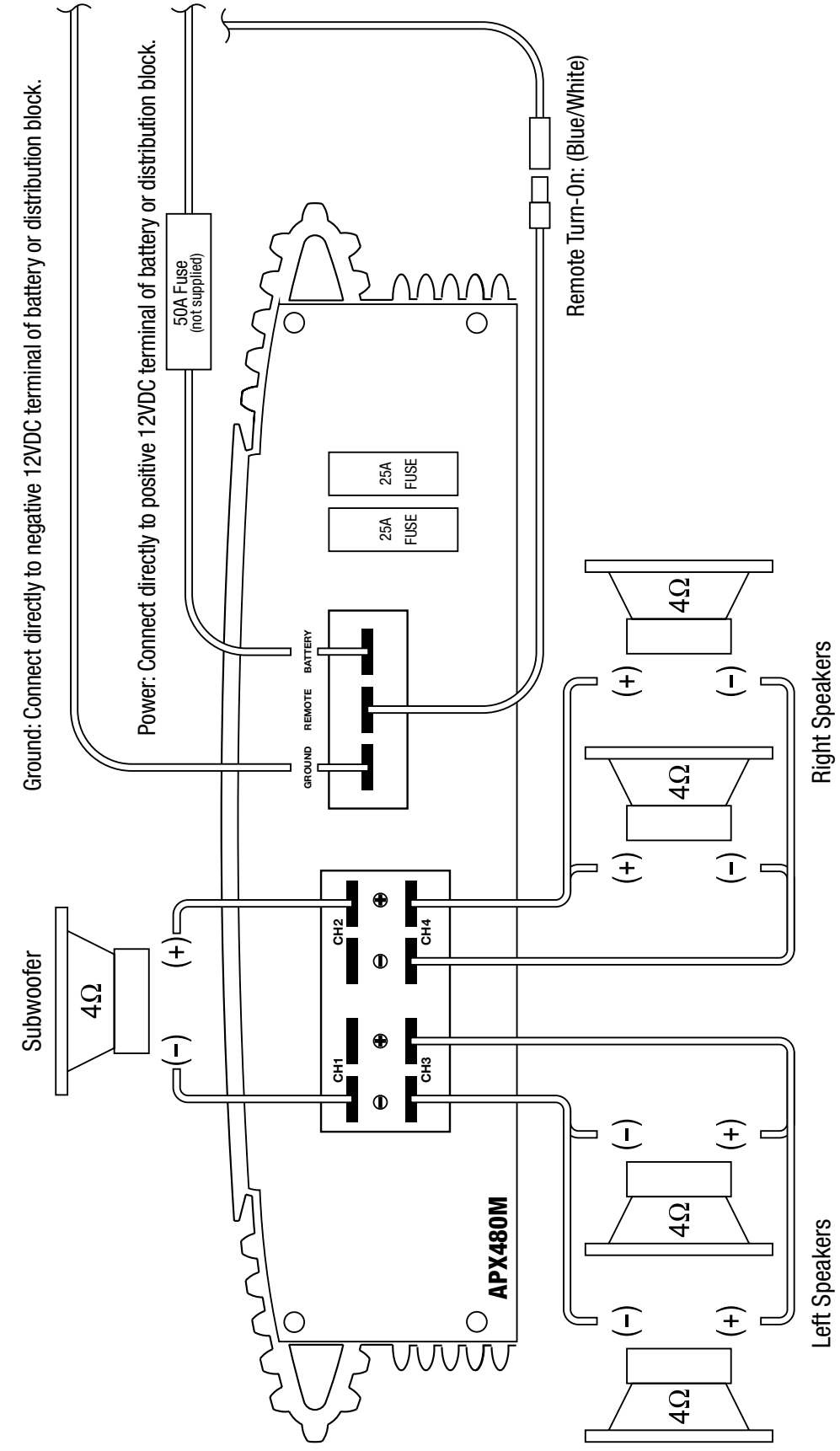

Ground: Connect directly to negative 12VDC terminal of battery or distribution block.

Power: Connect directly to positive 12VDC terminal of battery or distribution block.

**CLARION AMPLIFIER - APX480M  
CONNECTIONS & SETTINGS**



A G E N M A R C O M P A N Y

P A R T # 0 9 0 - 2 7 8 6

<https://www.boat-manuals.com/>