

Workshop Manual BMW D 12

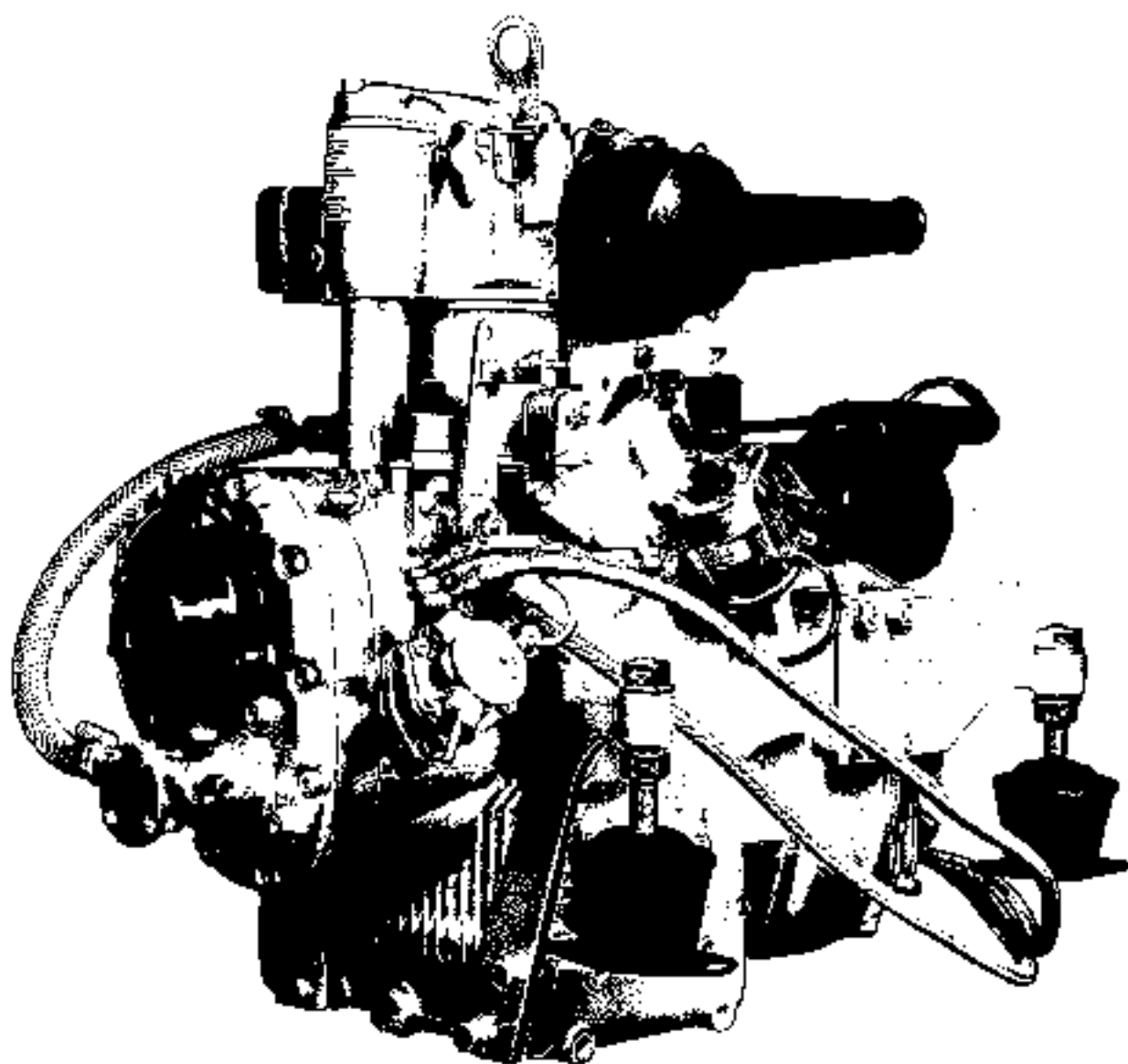

BMW Marine Engines

<https://www.boat-manuals.com/>



DESCRIPTION

The D 12 marine engine is a single-cylinder, four-stroke Diesel engine with direct injection. It features a single-circuit cooling system. The coolant pump with Neoprene impeller is driven directly from the crankshaft. The A.C. generator is located in the flywheel and, like the electric starter, is standard equipment. The injection pump is driven from the camshaft. The injection system bleeds itself automatically.

GENERAL

This manual describes the overhaul of the BMW D 12 marine engine when not installed. All removal, installation and overhaul jobs on a specific assembly (component) are always combined into one section and named after the assembly. The sequence of the sections corresponds to the job sequence in stripping the engine. Additionally, at the beginning of each section the jobs are listed which are required to remove (overhaul) the assembly (component) in each case, if the engine is not being completely stripped.

The job sequence for assembling the complete engine is given as a list of key words with the title "Job sequence in assembling the engine" following the overhaul sections.

The terms "top, bottom, front, rear, left, right" invariably are related, unless otherwise defined in the text, to the installed position of the engine as viewed in the direction of travel.

Figures in the manual are numbered consecutively throughout. When cross references are made to figures in the text, the figure No. is given first, followed by the item No. in the figure, e.g., (25/1) is a reference to Fig. 25, item 1.

Contents	Page
C	
Checking the functioning of Injection pump and injector	37
Checking the generator	11
Cooling system (schematic)	4
D	
Description	1
F	
Fuel system (schematic)	4
G	
General	1
I	
Installing the cylinder head	19
Installing the valves	26
J	
Job sequence in assembling the engine	50
M	
Measuring the valve projection	27
O	
Overhauling the injector nozzle	37
R	
Removing and installing retaining plate with engine electricals	6
Removing and installing the air filter	15
Removing and installing the bearing flange	14
Removing and installing the camshaft assembly	36
Removing and installing the connecting rod	47
Removing and installing the crankshaft	49
Removing and installing the cylinder	28
Removing and installing the decompression lever	27
Removing and installing the engine stop magnet	32
Removing and installing the exhaust manifold	16
Removing and installing the fuel control system	41
Removing and installing the fuel pump	32
Removing and installing the gearbox	7
Removing and installing the generator	8
Removing and installing the injection pump	34
Removing and installing the piston	46
Removing and installing the rocker arms	21
Removing and installing the rocker levers	41
Removing and installing the starter	7
Removing and installing the timing cover	33
Removing and installing the water pump	30
Removing the cylinder head	17
Removing the valves	25
S	
Service and maintenance	3
Setting the decompression device	23
Setting the engine speed	45
Setting the injection pump	35
Setting the valves	28
Special tools	54
Stripping and assembling the water pump	31
T	
Technical data and specifications	61
Tightening torques	54
W	
Winter lay-up and lengthy operating breaks	55
Wiring diagram	5

SERVICE AND MAINTENANCE

	Daily	Every 4 days	After every 50 op. hrs or once per year	Every 100 op. hrs or once per year	Every 150 op. hrs or ev. 2 years
Check engine oil	●				
Fuel filter (drain condensate and dirt)		●			
Engine oil change (first time after 10 hrs.)			●		
Check/set valves				●	
Change fuel filter				●	
Clean fuel pump screen				●	
Exchange air filter element				●	
Check gearbox oil level			●		
Change gearbox oil					●
Clean injector				●	
Check hoses and lines			●		
Clean injection pump	When necessary				
Exchange zinc anodes				●	
Check/exchange impeller (water pump)				●	
Set decompression device (always after valves have been set)				●	

COOLING SYSTEM

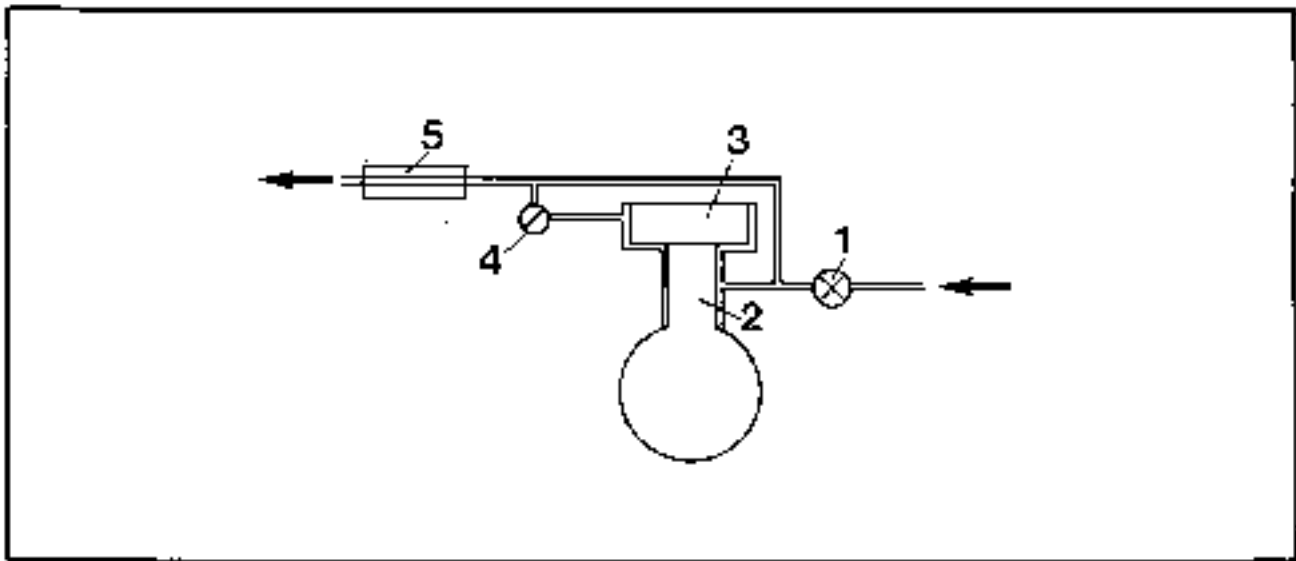

- 1) Water pump
- 2) Cylinder
- 3) Cylinder head
- 4) Thermostat
- 5) Exhaust pipe

FUEL SYSTEM

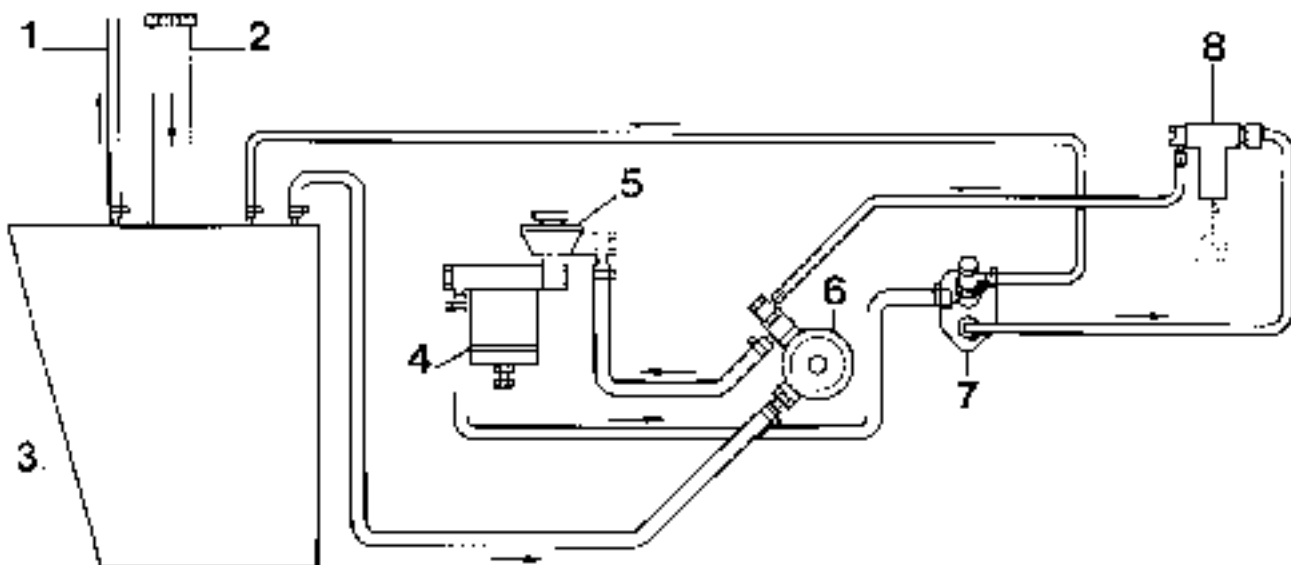

- 1) Tank vent
- 2) Filler neck
- 3) Fuel tank
- 4) Fuel filter
- 5) Hand pump
- 6) Fuel pump
- 7) Injection pump
- 8) Injector

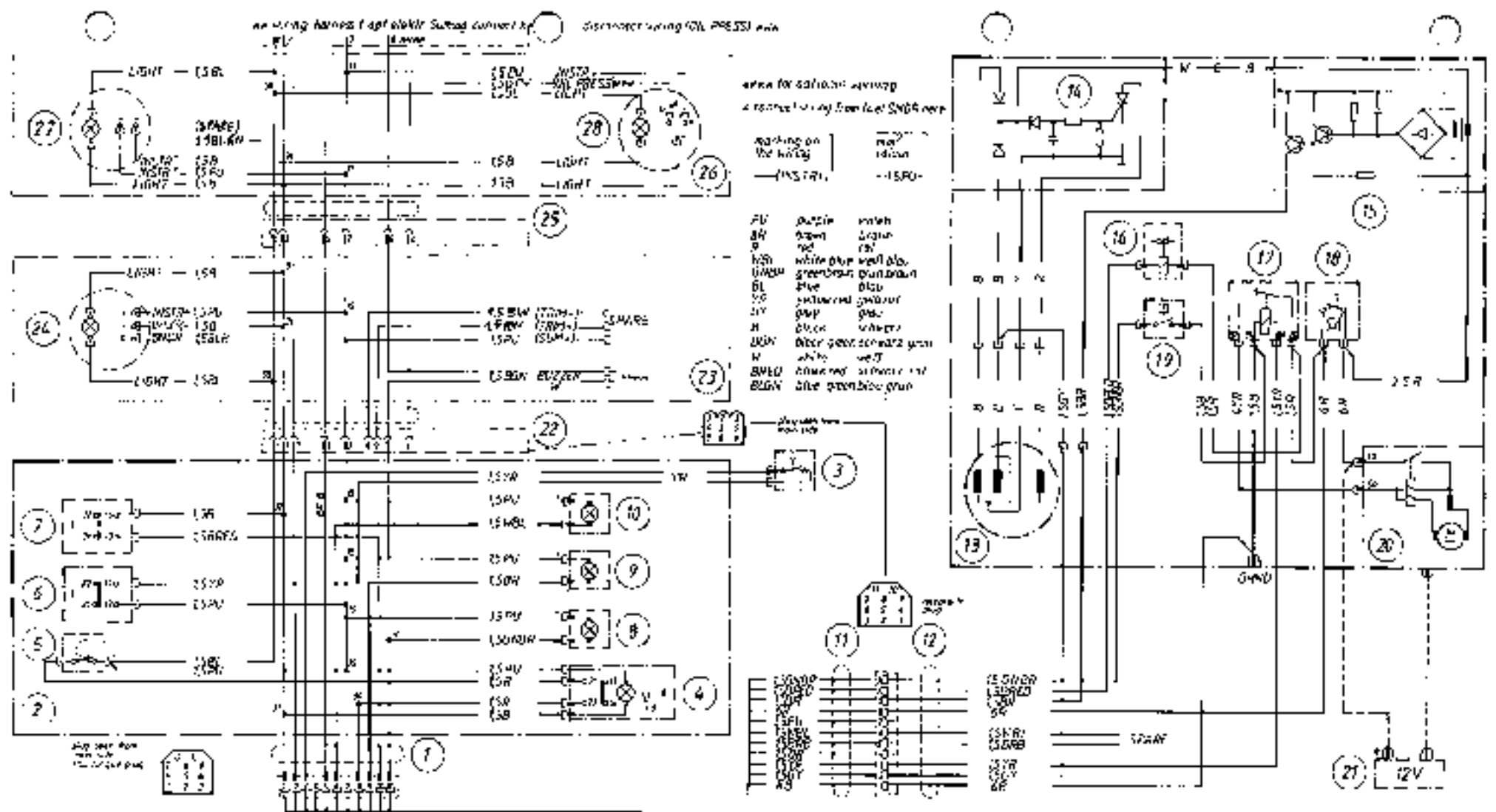

BMW Q12 Marine engine

1	Wasserpumpe mit Motor	11	Ablassventil mit Motor	21	Leuchte Vorder	
2	Wasserpumpe mit Motor	12	Wasserpumpe mit Motor	22	Zündschlüssel mit Motor	Sonderzubeh.
3	Wasserpumpe mit Motor	13	Generator (SWH)	23	Wasserpumpe mit Motor	Sonderzubeh.
4	Wasserpumpe mit Motor	14	Wasserpumpe mit Motor	24	Wasserpumpe mit Motor	Sonderzubeh.
5	Wasserpumpe mit Motor	15	Wasserpumpe mit Motor	25	Wasserpumpe mit Motor	Sonderzubeh.
6	Wasserpumpe mit Motor	16	Wasserpumpe mit Motor	26	Wasserpumpe mit Motor	Sonderzubeh.
7	Wasserpumpe mit Motor	17	Wasserpumpe mit Motor	27	Wasserpumpe mit Motor	Sonderzubeh.
8	Wasserpumpe mit Motor	18	Wasserpumpe mit Motor	28	Wasserpumpe mit Motor	Sonderzubeh.
9	Wasserpumpe mit Motor	19	Wasserpumpe mit Motor			
10	Wasserpumpe mit Motor	20	Wasserpumpe mit Motor			

Schaltplan
 electric diagram
Motor + Instrumente
 engine and instruments

REMOVING AND INSTALLING RETAINING PLATE WITH ENGINE ELECTRICALS

Removing retaining plate with engine electricals

Fig. 4

Sever the cable clamp. Pull back the rubber protective cap (4/1) on the starter and screw off the electrical lead (4/2). Disconnect the plug-in connector (4/3) from the starter. Disconnect the electrical leads from the temperature pick-up (4/4) and where an automatic engine shut-off device is fitted as special equipment, from the magnet (4/5) as well.

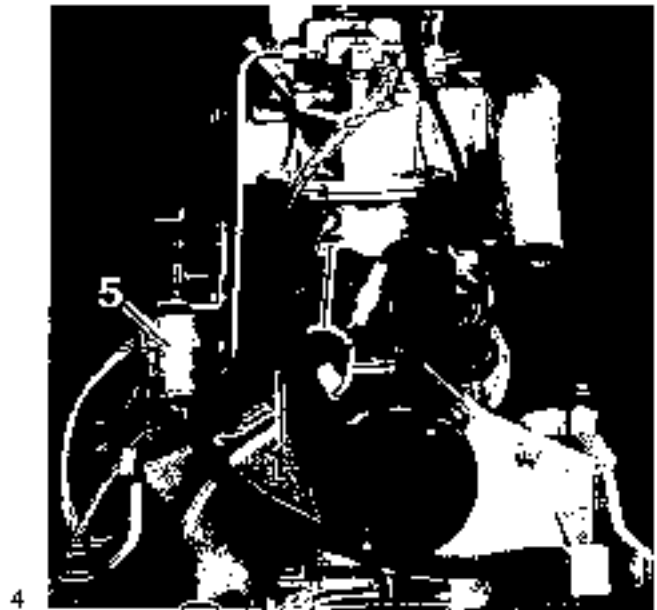

Fig. 5

Disconnect the four plug-in connectors (5/1) of the stator leads. Unacrow the two hex. nuts, remove the grounding cable (5/2) and take the retaining plate (5/3) off the flywheel housing.



Installing retaining plate with engine electricals.

Installation takes place in the reverse sequence to removal.

Caution:

Pay attention to polarity when the electrical leads are connected up.

REMOVING AND INSTALLING THE STARTER

Removing the starter

- Disconnect the electrical leads from the starter

Fig. 6

Loosen the two hex. nuts (6/1) and screw them back as far as they will go, pull back the starter and again unscrew the nuts as far as they will go. Repeat the process until the nuts are fully unscrewed. Remove the washers (6/2) from the threaded bolts and take the starter off the flywheel housing.



Installing the starter

Installation takes place in the reverse sequence to removal.

REMOVING AND INSTALLING THE GEARBOX

Removing the gearbox

- Remove the retaining plate with engine electricals
- Remove the starter

Fig. 7

Unscrew the four hex. nuts (7/1) and take them off together with the washers. Remove the flywheel housing cover (7/2) complete with gearbox from the engine.

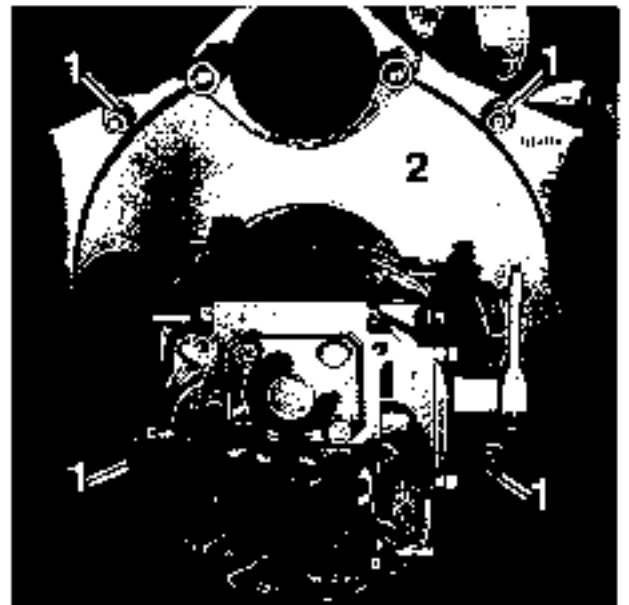
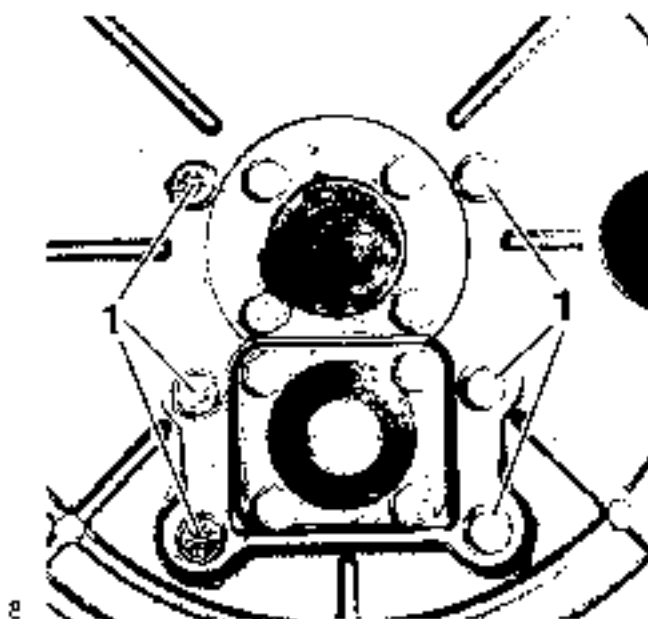

Fig. 8

Screw out the six hex.-head screws (8/1) and remove them together with the washers. Take the gearbox off the flywheel housing cover.



Installing the gearbox

Installation of the gearbox takes place in the reverse sequence to removal.

- Install the starter
- Install the retaining plate with engine electricals

REMOVING AND INSTALLING THE GENERATOR

- Remove the retaining plate with engine electricals
- Remove the starter
- Remove the gearbox

Removing the generator

Fig. 9

Screw out the four socket-head screws (9/1) and take the clutch disc (9/2) off the flywheel!

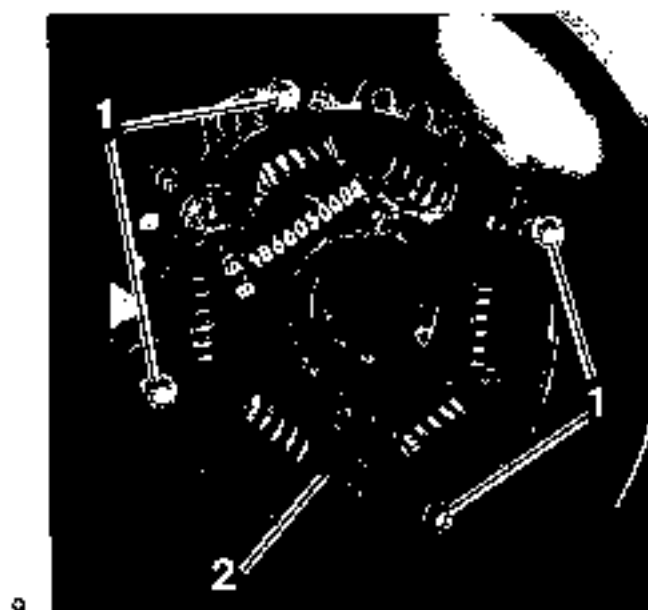
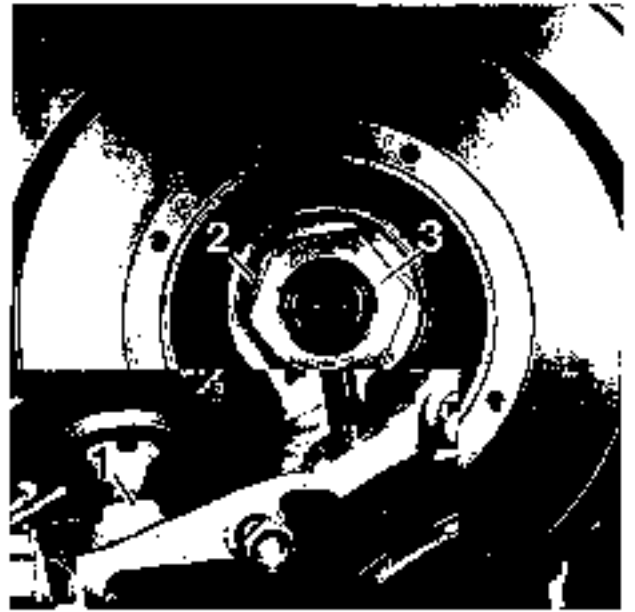

Fig. 10

Pull out the plastic plug (10/1) and block the flywheel with a screwdriver. Bend back the lock plate (10/2), loosen the hex. nut (10/3) with the socket wrench (special tool No. 74 64 1 333 559) and unscrew half way. Take off the socket wrench. Use a plastic hammer to knock the flywheel loose on the tapered shaft and unscrew the hex. nut fully to take the flywheel out of the flywheel housing.



10

Fig. 11

Should the flywheel not come loose by being knocked with the hammer, it can be pressed off with two levers, as illustrated.

Warning:

When the flywheel is being pressed off, make sure that it does not fall out of the flywheel housing.

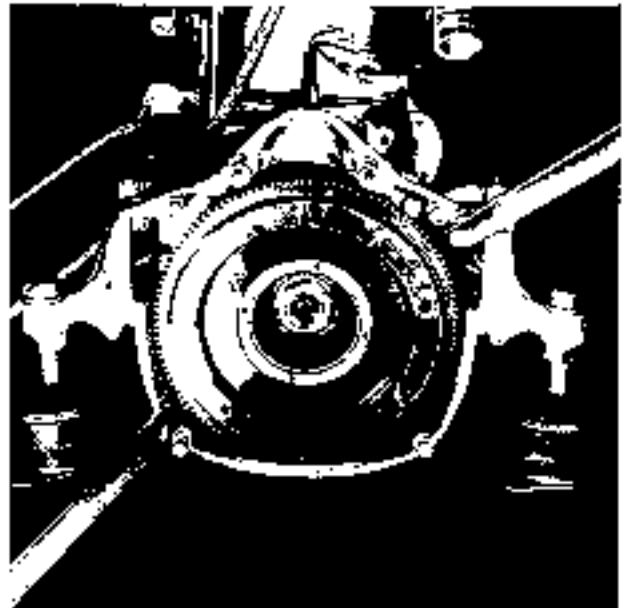

11

Fig. 12

Push the points of pointed pliers into the recesses in the rotor (12/1) and pull the tension spring (12/2) out of the rotor. Lift the rotor evenly and take it out of the flywheel.

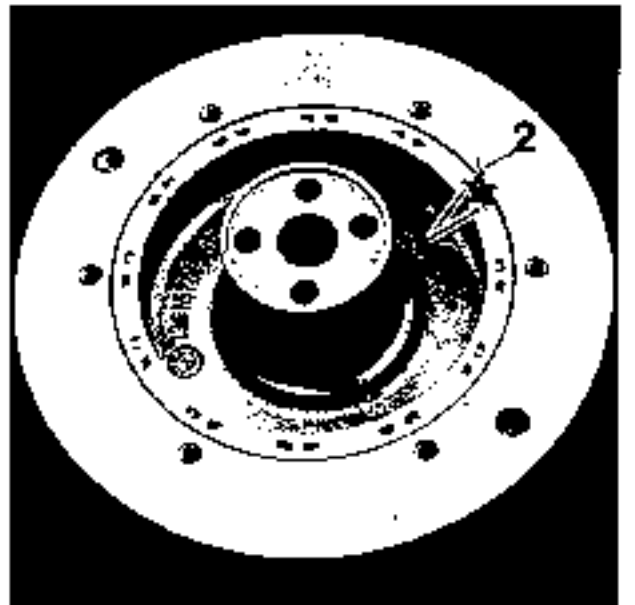

12

Fig. 13

Unscrew the two hex. nuts (13/1) in each case on the left-hand/right-hand sides of the flywheel housing ring (13/2), remove together with their washers and take the flywheel housing ring off the crankcase.



Fig. 14

Unscrew the hex. nut (14/1) and remove the clamp (14/2) from the stator cable.
Unscrew the four hex.-head screws (14/3) and take the stator (14/4) off the bearing cover.

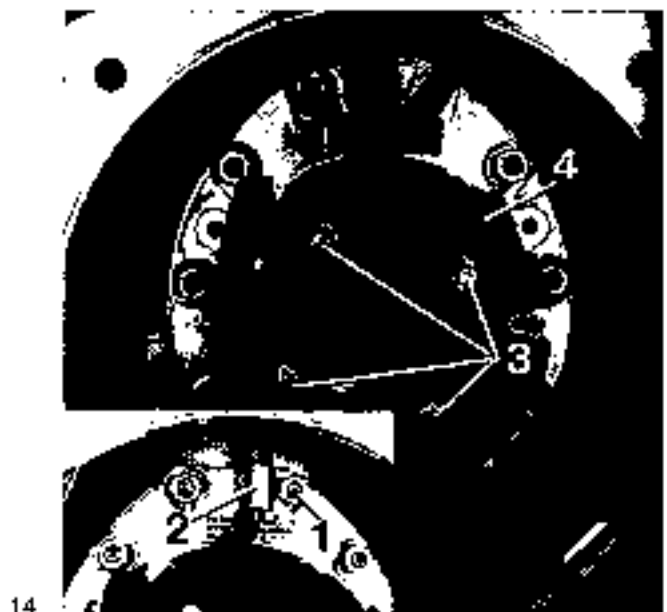

Installing the generator

Installation of the generator takes place in the reverse sequence to removal.

Caution:

The stator cables must rest closely against the crankcase, so that they are not caught up by the flywheel.

When the rotor is being installed, do not strike it with metallic tools, as otherwise it will be demagnetized.

Fig. 15

Note:

Examine the starter ring gear on the flywheel for damage, and if necessary exchange as follows:

Drill a hole into the starter ring gear (15/1) and break it open with a chisel. Heat the new ring gear to approx. 200° C and fit it on the locating part of the flywheel.

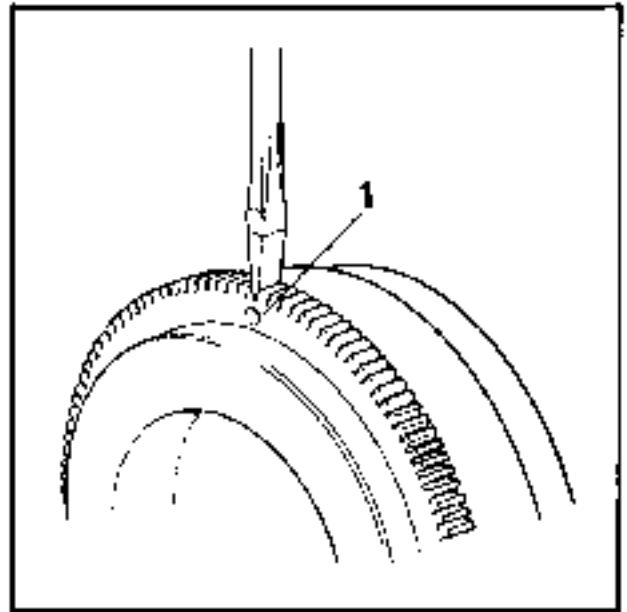

15

CHECKING THE GENERATOR

The generator works without mechanical contacts and without bearings. Faults generally arise from the wiring system for the generator (e.g., short circuiting, loose and incorrect connections).

When faults occur, first examine the wiring system for faults. Then make the appropriate checks of the generator on the engine (see wiring diagram).

Equipment is required for testing 0-15 DC and 0-250 AC voltage, as well as 0-40 A current and also a 12 V test lamp.

1. Checking the pulse generator

– 12 V test lamp

The thin, red lead of the pulse generator grounds the charge indicator when the engine is stationary.

As soon as charging current (coming from the regulator / cutout) flows through the pulse generator, this connection to ground is interrupted.

- To check, disconnect the thin, red lead from the wiring system and connect up a test lamp between B+ (charging current cable) and the thin, red lead of the pulse generator.
When the engine is at a standstill, the test lamp must light up; when the engine is running (at approx. 1150 r.p.m.) the test lamp must be extinguished.
- If the lamp is not extinguished, either the pulse generator is defective and must be exchanged or the generator is not delivering any charging current.

Figs. 16 and 17

2. Checking charging current

0...40 A ammeter

Charging current is flowing from the regulator/output (white cable) to B+ (terminal 30).

- To measure the charging current, disconnect the thick, red cable from the wiring system with the engine shut off and interpose the ammeter. Start the engine and load the battery (by switching on several items of electrical equipment).
- Should the ammeter show no charging current or insufficient charging current, either the regulator/output or the generator is defective.
- To further narrow down the sources of the fault, measure the voltage between each one of the two black cables and the red cable of the generator.

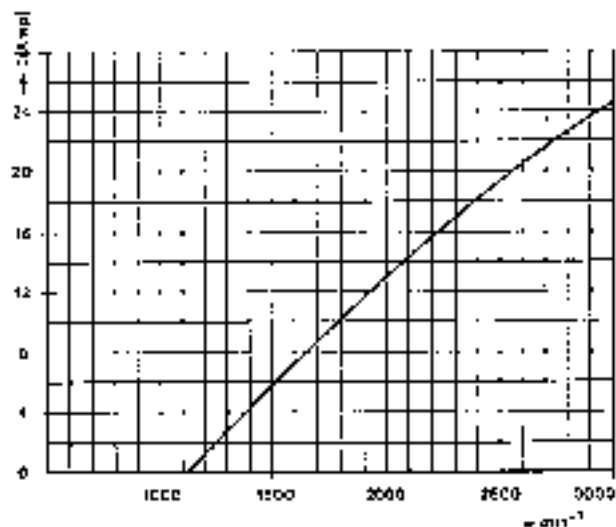

16

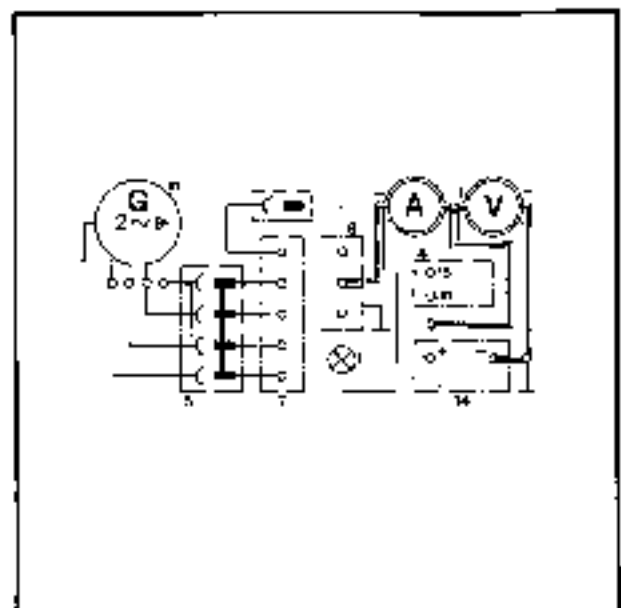

17

Figs. 18 and 19

3. Measuring the voltage (without load)

0...250 V voltmeter (AC) This measurement enables the generator to be checked without regulator/cutout and battery.

- With the engine at a standstill, disconnect the generator from the regulator/cutout for this measurement (the black cables and the red cable) and connect one black cable and the red cable to the voltmeter.
- Fix the other loose black cable so that it cannot be grounded.

Warning:
HIGH TENSION

- Start engine, set to maximum speed and compare voltmeter reading with the specified voltages, see graph.
- Repeat the measurement with the second black cable. If the specified voltages are obtained in both measurements, the generator is in order. In this case, inadequate charging current can only be caused by outside components (e.g., regulator/cutout). Should the specified voltages not be obtained (in principle, a difference between cable I and cable II being feasible), there are two possibilities: if the voltages are below the specified ones in the case of both cables, the rotor magnetization is insufficient and the rotor must be exchanged. Should the voltage measured be below the specified voltage in the case of only one cable, this indicates a fault in the windings and the stator must be exchanged.

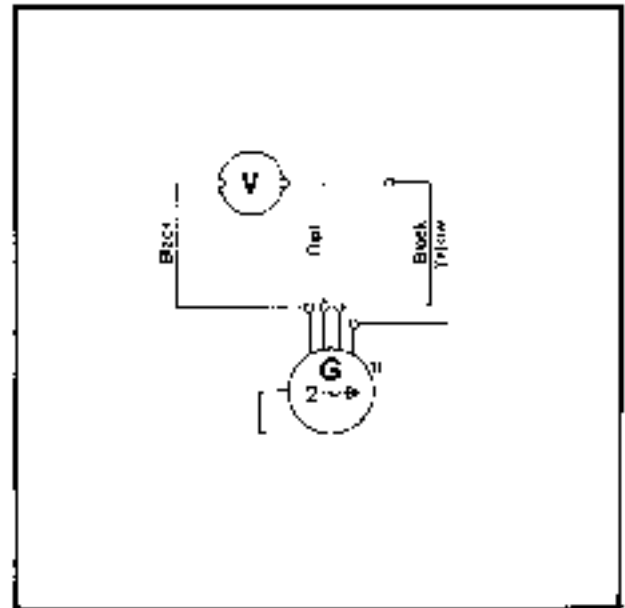

18

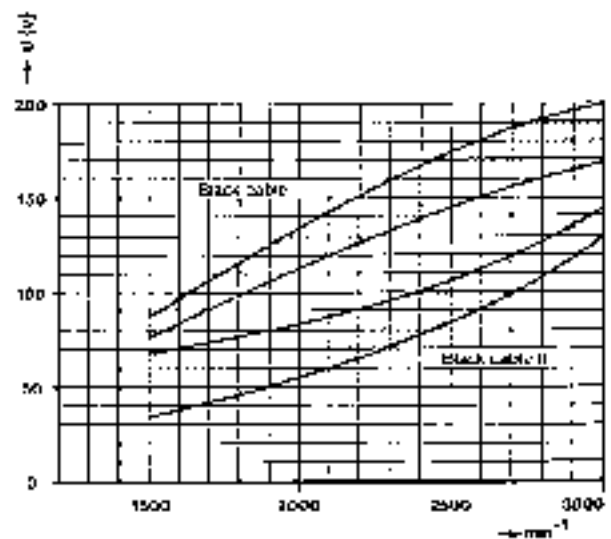

19

REMOVING AND INSTALLING THE BEARING FLANGE (ON FLYWHEEL SIDE)

- Remove the generator

Removing the bearing flange

Fig. 20

Bend back the tab washers (20/1), unscrew the nine hex. nuts (20/2) and remove them together with the washers. Heat the crankcase to approx. 80° C, screw four bolts into the holes (20/3) and press the bearing flange of the crankcase.



20

Fig. 21

Examine the shaft seal (21/1) for damage and renew, if necessary. To press out the bearing outer race (21/2), unscrew the hex.-head screws (20/4), take off the bearing cover (20/5), heat the bearing flange to approx. 150° C and press out the outer race.

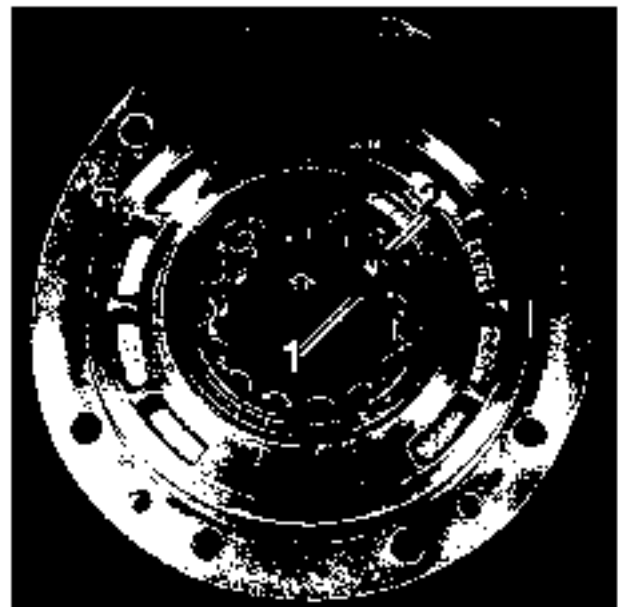

21

Installing the bearing flange

Installation of the bearing flange takes place in the reverse sequence to removal.

Note:

Fill up the shaft seal groove between dust lip and sealing lip (arrow) with ball-bearing grease, so that the dust lip does not run dry.

Coat the holes in the crankcase with Molykote.

Tighten the bearing flange nuts with a tightening torque of 30 Nm. Use new tab washers. Use normal washers and not tab washers for the two lower nuts.

REMOVING AND INSTALLING THE AIR FILTER

Removing the air filter

Fig. 22

Undo the three clips (22/1) and take off the filter cover (22/2).

22

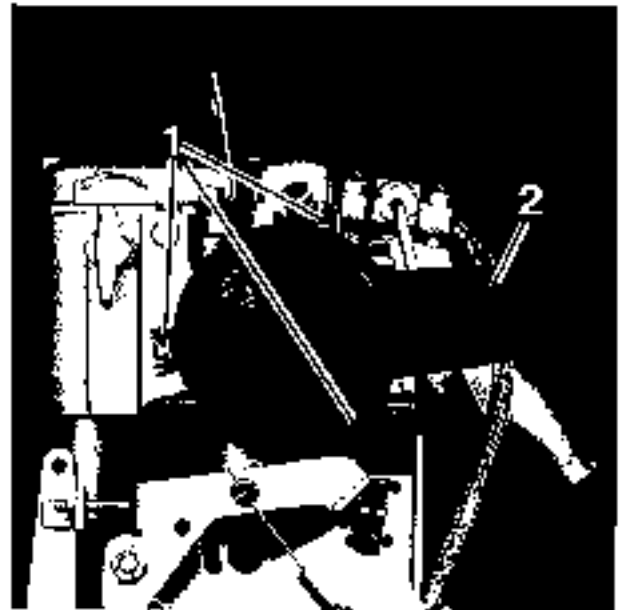
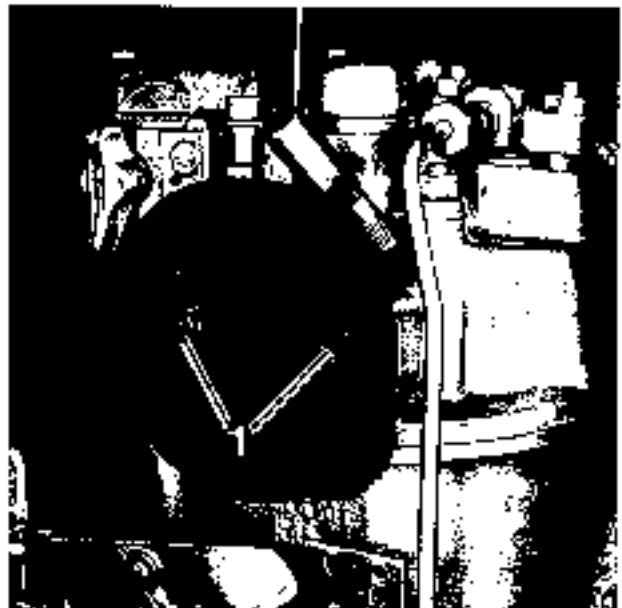

Fig. 23

Remove the filter element, unscrew the two hex. nuts (23/1) and remove the lower part of the filter housing with seal from the cylinder head.

23



Installing the air filter

Installation takes place in the reverse sequence to removal.

REMOVING AND INSTALLING THE EXHAUST MANIFOLD

Removing the exhaust manifold

- Disconnect the lead from the temperature pick-up

Fig. 24

Unscrew the union nut (24/1) and remove the water pipe (24/2) from exhaust manifold and cylinder. Screw out the six hex-head screws (24/3) and remove the exhaust manifold (24/4) from the cylinder head.

24

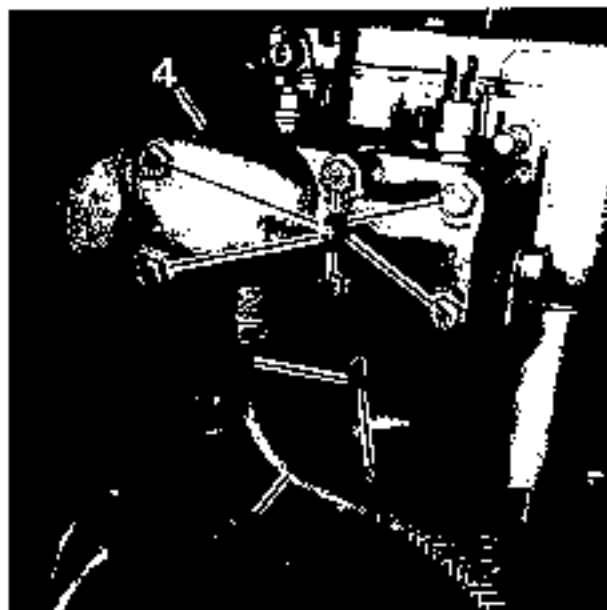
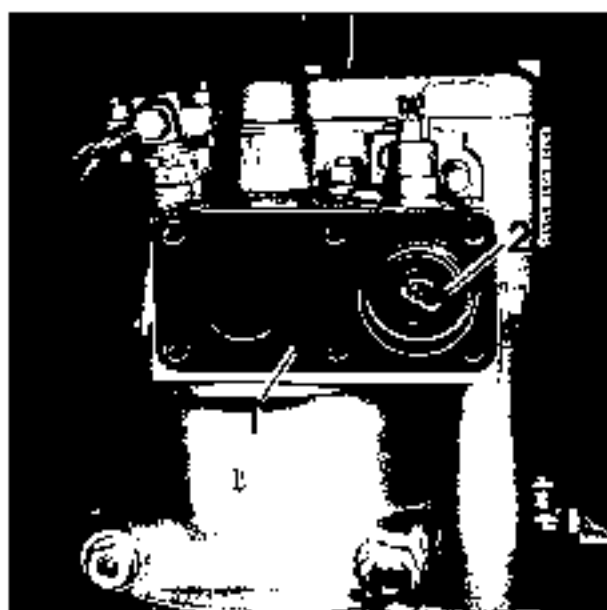

Fig. 25

Remove the gasket (25/1) and the thermostat (25/2) from the cylinder head.

25



Installing the exhaust manifold

Installation of the exhaust manifold takes place in the reverse sequence to removal.

Note:

Fig. 26

Place a new O-ring (26/1) on the thermostat, smear the thermostat with a slight coat of grease to fix it in position and place it in the cylinder head. The thermostat is designed to start to open at 45° C.

26



REMOVING AND INSTALLING THE CYLINDER HEAD

Removing the cylinder head

Fig. 27

Screw out the hex.-head screw (27/1) and remove the pipe clamp (27/2) from the high-pressure line (27/3). Unscrew the two union nuts (27/4) and remove the high-pressure line between injection pump and injector.



Fig. 28

Unscrew the hollow screw (28/1) and remove the return-line (28/2) from the injector. Unscrew the two hex. nuts (28/3) and take the injector out of the cylinder head. Take the sealing ring and gasket out of the cylinder head.

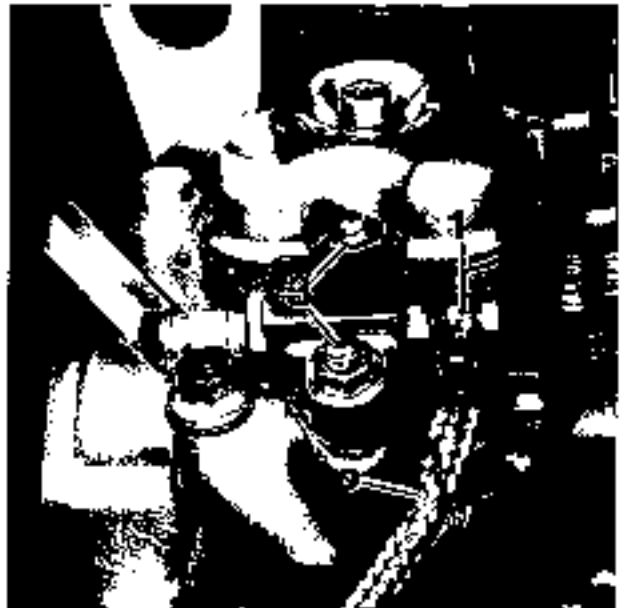

Fig. 29

Screw out the socket-head screw (29/1) and remove the carrier bracket (29/2) from the cylinder head. Screw out the two socket head screws (29/3), remove them together with their spring washers and take the valve cover (29/4) together with seal off the cylinder head.

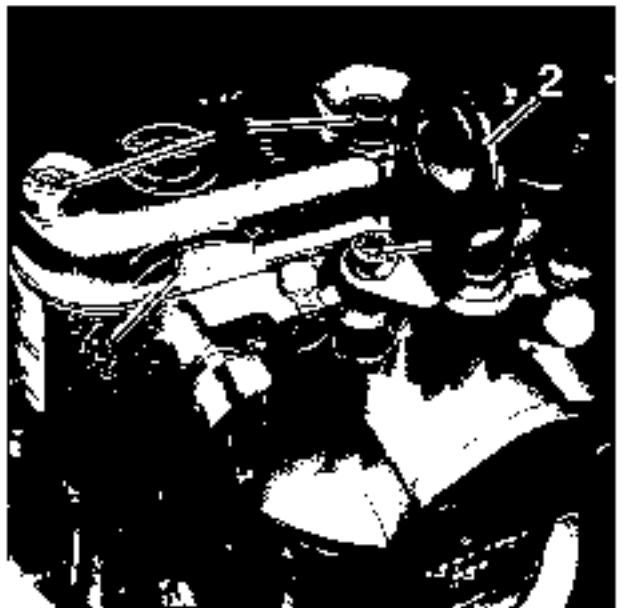

Fig. 30

Unscrew the four cylinder-head nuts (30/1) uniformly and remove together with their washers. Take the cylinder head off the cylinder.

30

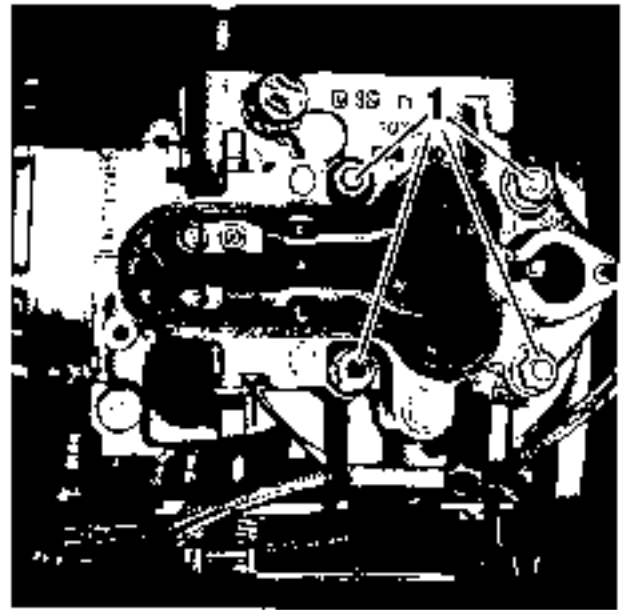

Fig. 31

Remove the push rods (31/1). Remove the protective tube (31/2) together with O-rings from the crankcase.

31

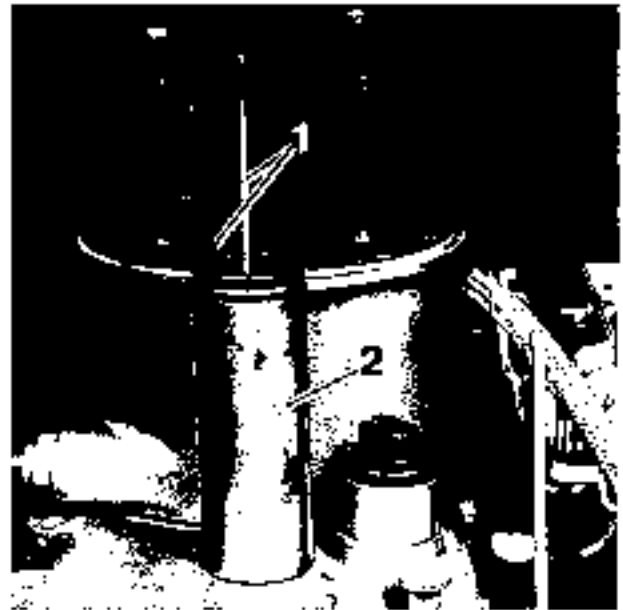
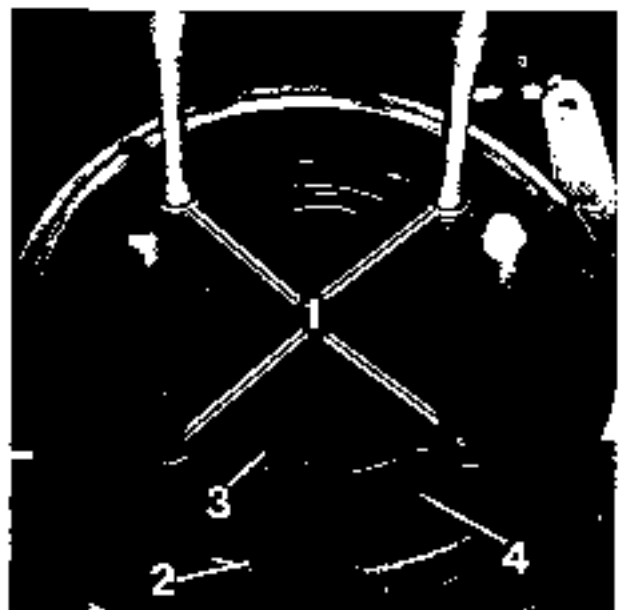

Fig. 32

Take the O-rings (32/1,2) and cylinder-head gaskets (32/3,4) off the cylinder.

32



Installing the cylinder head

Fig. 33

Clean the seating faces on the cylinder and on the cylinder head and examine them for damage. Check the cylinder-head seating face for distortion and the firm seating of the combustion chamber (33/1), exchanging the cylinder head, if necessary. Check the valves for leakage and their setback, see "Removing and installing the valves". Place new cylinder-head gaskets on the cylinder. Fit new O-rings in the cylinder.

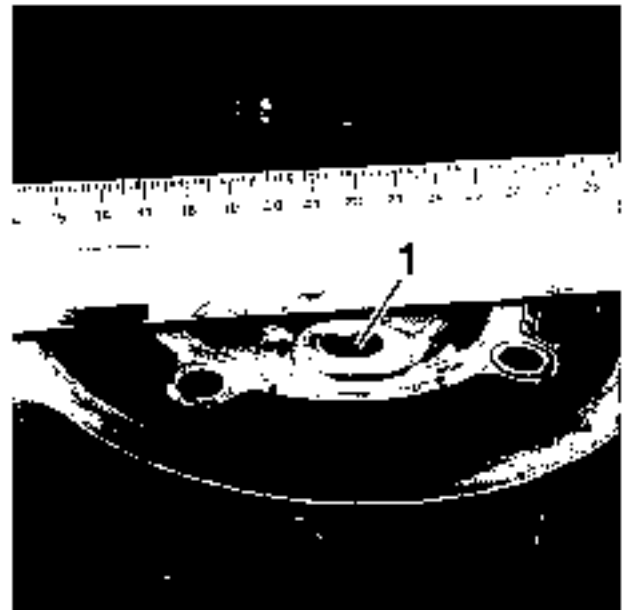

33

Note:

Fig. 34

When the outer gasket (34/2) is placed on the cylinder, fit the lug (34/1) into the locating hole (34/3) in the cylinder.



34

Fig. 35

Place the lower O-ring for the protective tube in the recess in the crankcase. Fit the protective tube (35/1) and place the pushrods (35/2,3) on the rocker levers.

Note:

Place the pushrod (35/2) with the collar pin (35/4) on the front rocker lever. Move the pushrods round 90° clockwise.

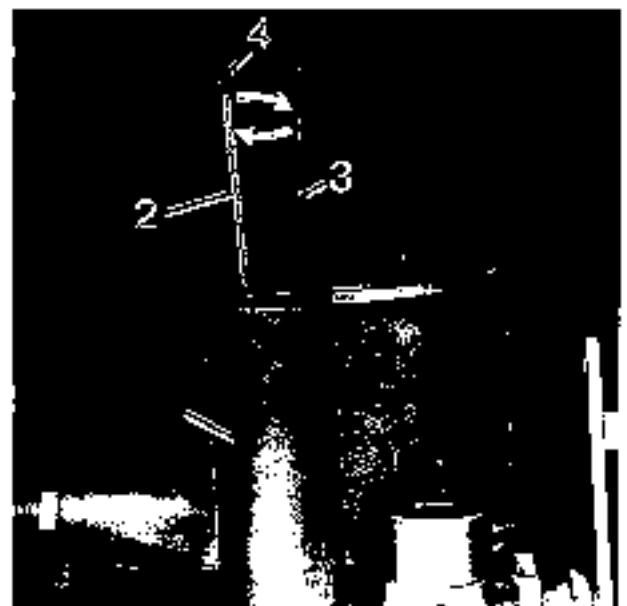

35

Fig. 36

Fit the upper O-ring (36/1) for the protective tube with a little grease into the cylinder head.



36

Fig. 37

Place the cylinder head on the cylinder and apply the pushrods to the rocker arms. Screw on the three hex. nuts (37/1) and one collar nut (37/2) and screw the cylinder head down on the protective tube side until it's seated. Use one washer for each nut. Tighten the four nuts diagonally and uniformly with a tightening torque of 65 Nm.

- Set the valves
- Set the decompression device

Place a new valve cover seal (37/3) in position, fit the valve cover on the cylinder head and tighten with the two socket-head screws. Use a sealing ring with each screw.

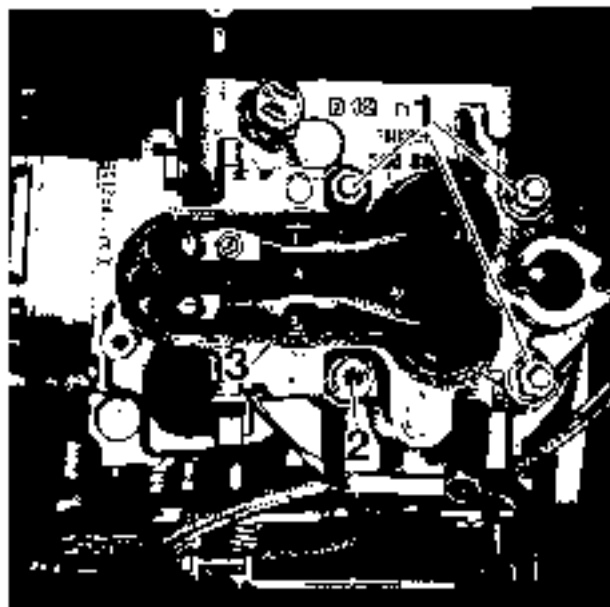

37

Fig. 38

Place the carrier bracket (38/1) on the collar nut (38/2) and screw it tight with socket-head screw (38/3). Fit the sealing ring (38/4) and gasket (38/5) into the cylinder head, fit the injector (38/6) and screw it tight with the two hex. nuts (38/7).

Install the high-pressure line and the return line, see Figs. 27 and 28

- Install the air filter
- Install the exhaust manifold



38

REMOVING AND INSTALLING THE ROCKER ARMS

Removing the rocker arms

- Remove the valve cover

Fig. 39

Screw out the water temperature pick-up (39/1), bend up the tab washers (39/2) and screw the two hex.-head screws (39/3) out of the rocker arm shaft.



39

Fig. 40

Use a drift to knock the rocker arm shaft (40/1) out of the cylinder head and take the rocker arms out of the cylinder head. Pay attention to any shims.

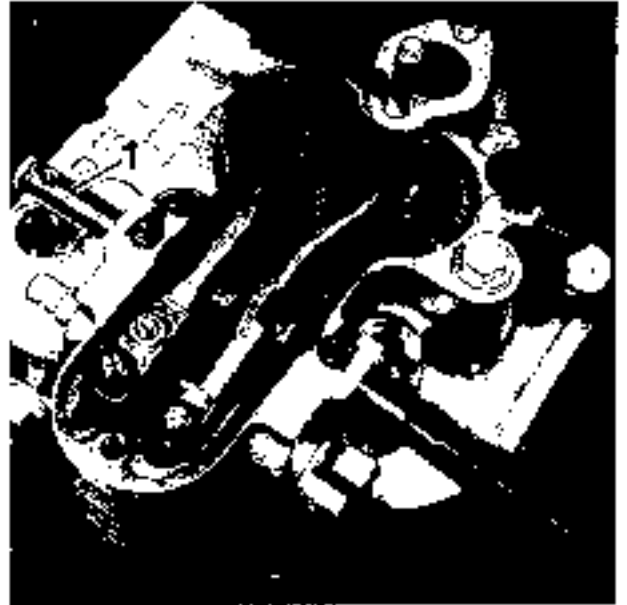

40

Installing the rocker arms

Installation takes place in the reverse sequence to removal.

Note:

Fig. 41

Place a new O-ring (41/1) on the rocker arm shaft (41/2), oil the shaft, insert the end of the shaft without O-ring into the hole in the cylinder head and fit the rocker arms on to the shaft as it is being pushed through. Oil and fit the second O-ring.

Measure the axial clearance (0,05 mm) of the rocker arms with a feeler gauge and correct with shims (41/3), if necessary.

- Set the valves
- Set the decompression device



41

REMOVING AND INSTALLING THE DECOMPRESSION LEVER

Removing the decompression lever

- Remove the cylinder head

Fig. 42

Knock the spring pin out of the decompressor shaft (42/1).

42

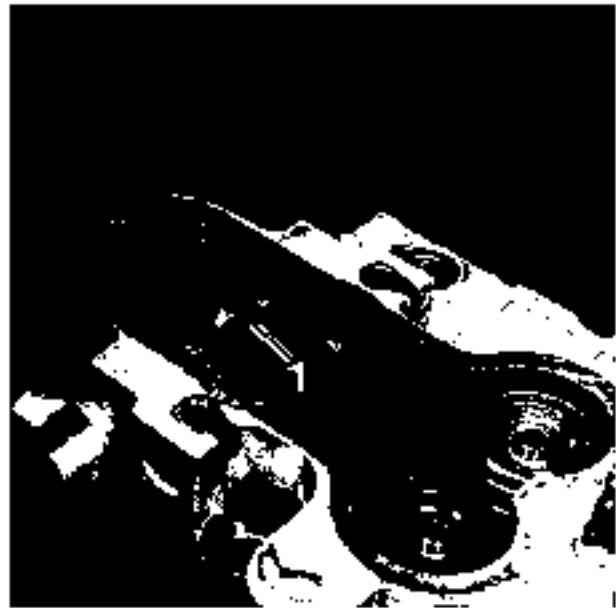

Fig. 43

Turn over the cylinder head, screw out the headless screw (43/1) and remove the spring (43/2). This frees the shaft.

43



Fig. 44

Disengage the two circlips (44/1) from the shaft and use a suitable drift to knock the shaft out of the cylinder head.

44



Installing the decompression lever

Figs. 45 and 46

Fit the O-ring (45/1) on the lever side of the shaft (45/2) and oil it. Push the shaft half way through the cylinder head, fit the gear segment on the shaft, engage the circlip (45/3) in its groove and push the shaft so far through the cylinder head that the second O-ring (45/4) can be pushed on from the outside. Fit the O ring and oil it. Pull the shaft back until the circlip is stopped and engage the second circlip (45/5) in its groove. Fit the locking pin (45/6) with new O-ring (45/7) from below into the cylinder head, fit the spring (45/8) and headless screw (45/9) and set the locking pin such that the shaft can be turned with slight resistance. Turn the gear segment (46/1) so that the flattened side (46/2) of the shaft faces the teeth. Fix the gear segment on the shaft with the spring pin (46/3).

- Install the cylinder head
- Set the decompressor device

45

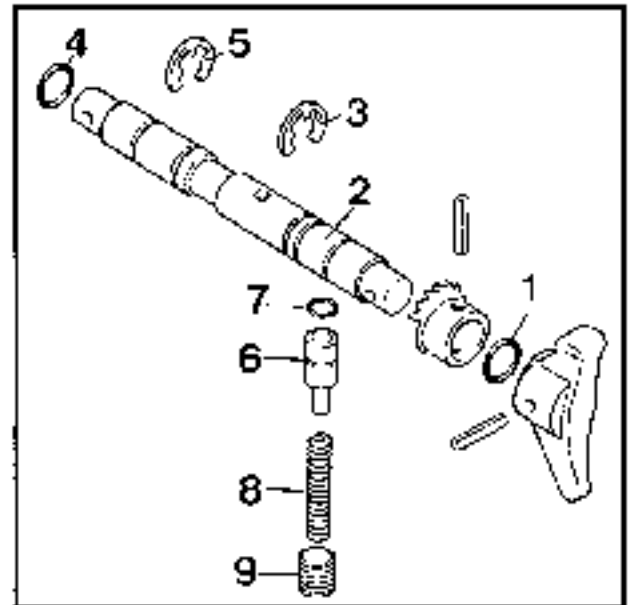

46



Setting the decompression device

Note:

Should the engine not be decompressed when the decompression lever is in position "1", set the decompression device as follows:

- Remove the valve cover (see "Removing the cylinder head")
- Check the valve clearance and adjust, if necessary.

Fig. 47

Shift the decompression lever to the "0" position and turn the engine over in the direction of rotation (anticlockwise, looking at the flywheel) until resistance from compression is felt. Shift the decompression lever to position "2".

47

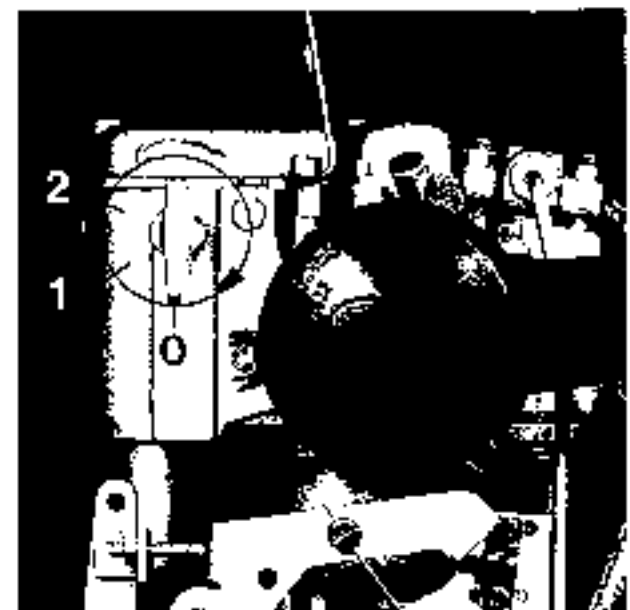
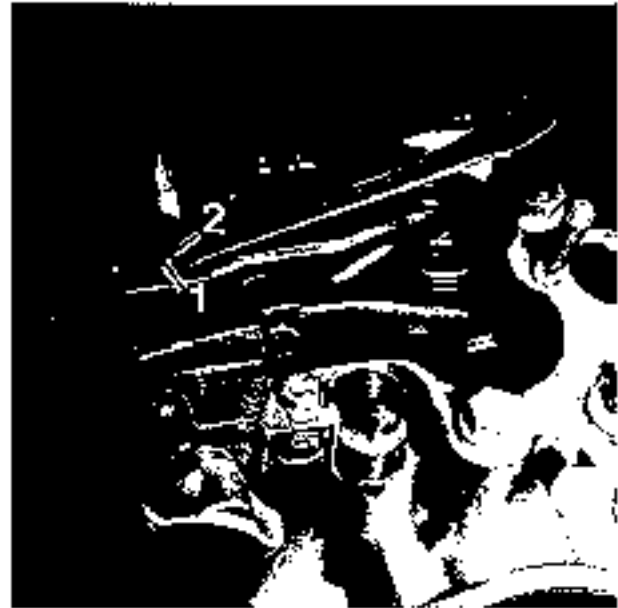

Fig. 48

Unscrew the nut (48/1) and turn the adjusting screw (48/2) until the rocker arm just touches the valve stem. From this position, turn the adjusting screw another half turn clockwise and lock it by tightening the nut.



48

Fig. 49

When the decompression lever is shifted to position "2", it must automatically move round to position "0" when the engine is turned over. If it does not, the push rod featuring the collar part must be lengthened somewhat, i.e., gap "A" becomes smaller.

Should the collar part have permanent slight contact with the gear segment (decompression lever moves slightly to and fro) when the engine is running and the decompression lever is in the position "0", the push rod must be shortened somewhat, i.e., gap "A" becomes larger.

- Install the valve cover (see "Installing the cylinder head")

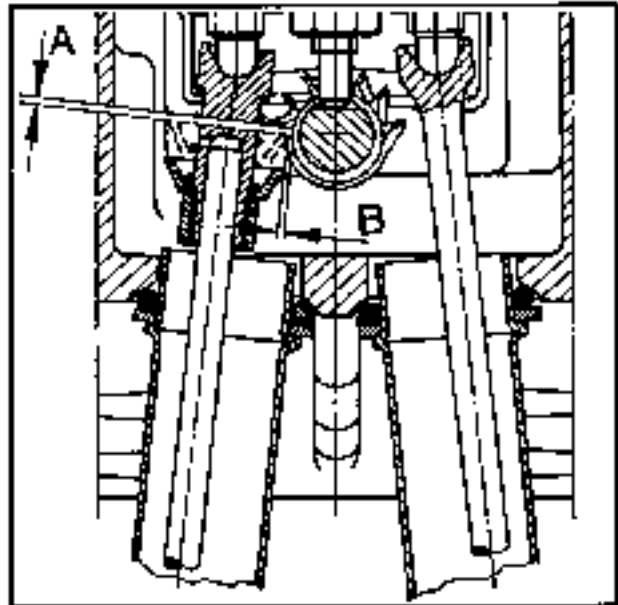

49

REMOVING AND INSTALLING THE VALVES

Removing the valves

- Remove the cylinder head
- Remove the rocker arms

Fig. 50

Press the valve spring (50/1) down, take out the valve spring keys (50/2) and gradually relax the spring.



50

Fig. 51

Take the spring plate (51/1), valve spring (51/2), washer (51/3) and cap (51/4) off the valve stem.



51

Fig. 52

Turn over the cylinder head and take the valves out of the cylinder head on the combustion-chamber side. Examine the sealing face (52/1) and land (52/2) between the valves for cracks and unevenness and exchange the cylinder head, if necessary.



52

Fig. 53

Examine the valve guides (53/1) for damage and, if necessary, press them out from the combustion-chamber side with the cylinder head cold.

53

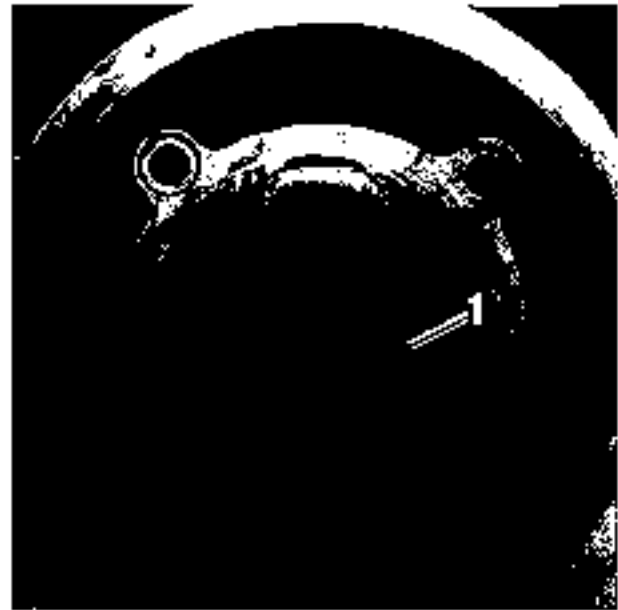

Fig. 54

Press in new valve guides with a minimum pressure of 1000 N from the combustion-chamber side with the cylinder head cold.

Caution:

After the new valve guides have been pressed in, use the hand reamer, special tool No. 74 64 1 333 532, to ream out the guides.

54



Installing the valves

Fig. 55

Prior to installation, check the valves for leakage, as follows

Fit the valves and fill fuel into the inlet and exhaust ports. If the fuel seeps through, the valve seats must be ground in with special tool No. 74 64 1 333 539. For this purpose, use grinding paste.

55



Fig. 56

Should the valve seat faces be in very poor condition, the valve seats must be refaced with the 45° valve resseating tool, special tool No. 74 64 1 333 55*, in conjunction with No. 74 64 1 333 534 and No. 74 64 1 333 546.

Caution:

Mill down only so far that the valve seat is without flaws.

Then: grind in the valves, as described in Fig. 55



56

Fig. 57

Measure the valve projection "R" from the sealing face to the valve disc. If the specified projection is exceeded (see "Technical Data"), the cylinder head must be exchanged.

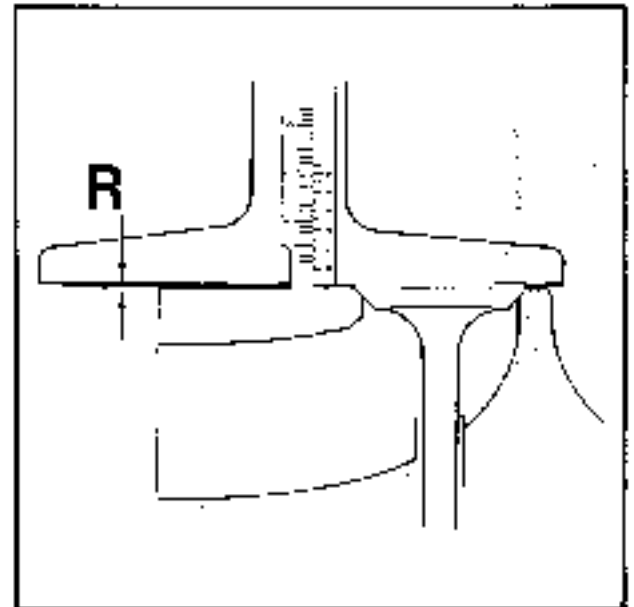

57

Fig. 58

Place the cap (58/1), washer (58/2), valve spring (58/3) and spring plate (58/4) on the valve stems, press the valve springs down and fit the valve spring keys (58/5).

- Fit the rocker arms
- Install the cylinder head

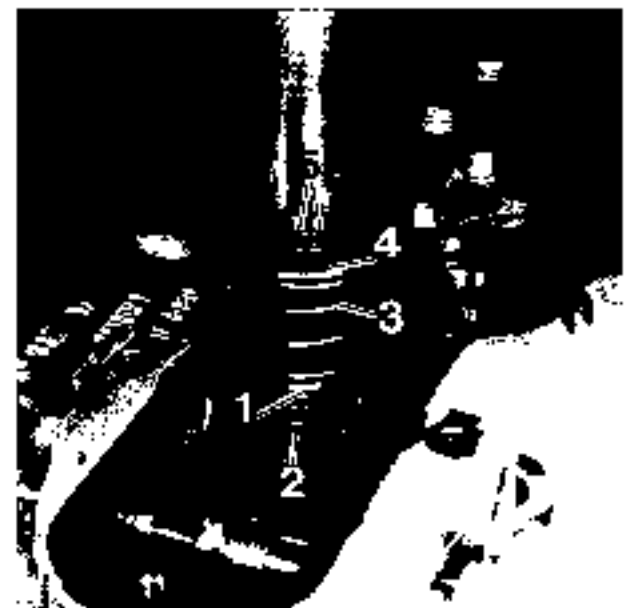

58

Setting the valves

- Remove the valve cover (see "Removing the cylinder head")

Fig. 59

Shift the decompression lever (59/1) to the position "O". Turn the engine in the direction of rotation until resistance from compression is felt. Push a feeler gauge between valve stem and rocker arm. Loosen the lock nut (59/2) and turn the adjusting screw (59/3) so far until the feeler gauge can be moved with slight resistance. Tighten the lock nut. Check the clearance once again.



See "Technical Data" for valve clearance

- Install the valve cover (see "Installing the cylinder head")

REMOVING AND INSTALLING THE CYLINDER

Removing the cylinder

- Remove the cylinder head

Fig. 60

Take the cylinder (60/1) off the crankcase. Pay attention to the shims (60/2). Note the thickness of the shims.

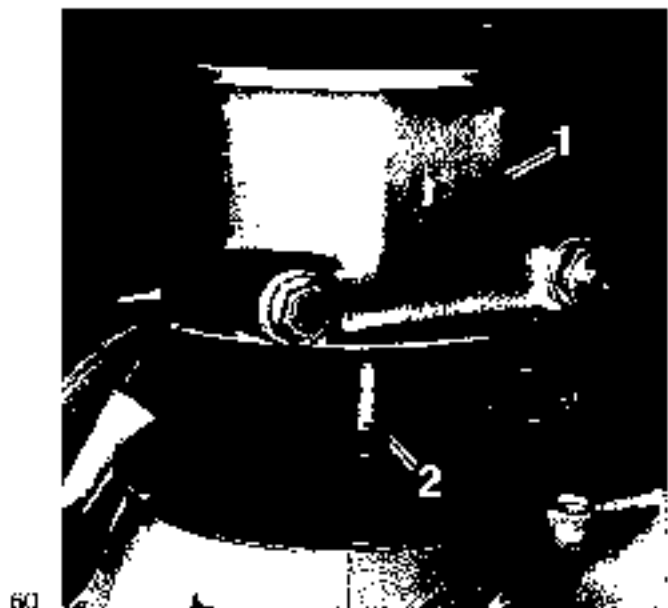

Installing the cylinder

Fig. 61

Check the cylinder bore (arrow) for seizing marks, longitudinal scores and wear (max. 0,15 mm).

Place shims (61/1) of the noted-down thickness on the cylinder.



61

Fig. 62

Oil the piston, piston rings and the cylinder bore. Stagger the piston ring gaps and apply the piston ring strap, special tool No. 74 64 1 333 560. Push the cylinder on carefully, so that no piston rings are broken. Once all three piston rings are inside the cylinder, take off the piston ring strap and push the cylinder fully on to the crankcase.

- Measure piston projection
- Install the cylinder head



62

Measuring piston projection

- Remove the cylinder head

Fig. 63

Bring the piston to T.D.C. Clamp down the cylinder with the clamp, special tool No. 74 64 1 333 561. Fit the dial gauge, special tool No. 74 64 1 333 546, in the measuring bridge, special tool No. 74 64 1 333 544, and preload it when setting it down.

Place the dial gauge feeler on the top edge of the cylinder (63/1) and set the pointer to zero.

Place the dial gauge feeler on the top edge of the piston (63/2), note the pointer reading and subtract this value from the thickness of the cylinder-head gasket (1,5 mm). The figure obtained is the distance the piston projects. Should the figure obtained not tally with the specified ones (0,90 – 0,90 mm), it must be corrected by adding or removing shims (61/1) underneath the cylinder (see "Technical Data" for thickness).

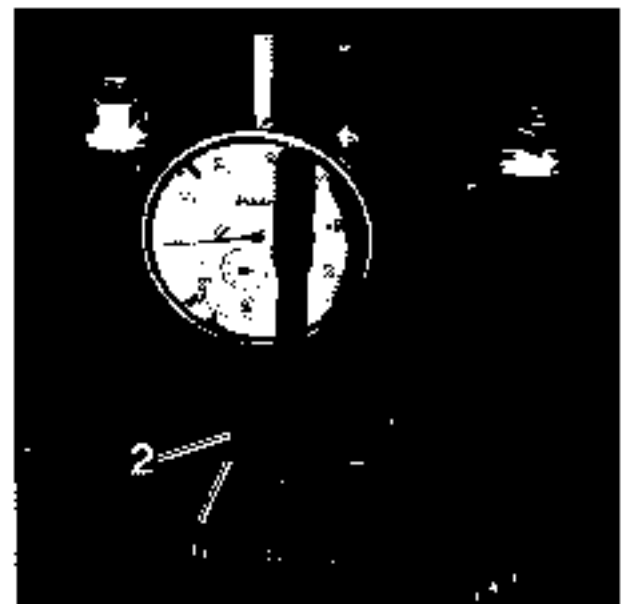

63

Example for calculating the piston projection:

Thickness of cylinder-head gasket	1,50 mm
Reading obtained	-0,65 mm
Piston projection	- 0,85 mm

- Install the cylinder head

REMOVING AND INSTALLING, STRIPPING AND ASSEMBLING THE WATER PUMP

Removing the water pump

- Remove the cooling water hoses

Fig. 64

Unscrew the two hex nuts (64/1), remove them together with the spring washers and take the water pump off the crankcase.

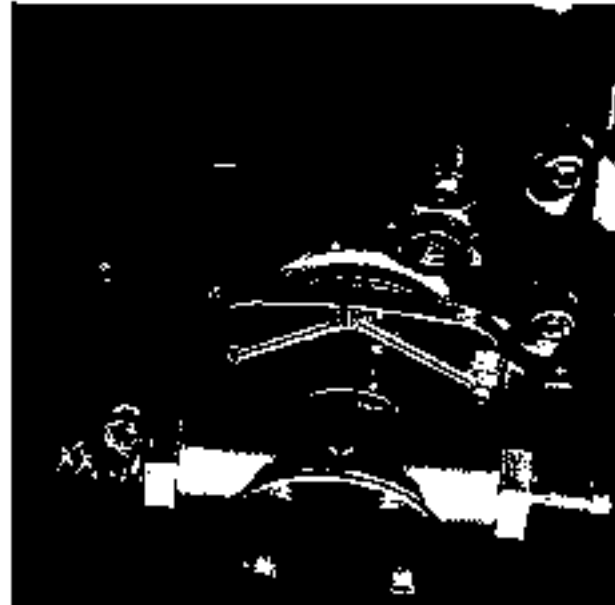

Installing the water pump

Installation takes place in the reverse sequence to removal.

Fit a new O-ring (65/17) on the pump flange.

Stripping the water pump

Fig. 65

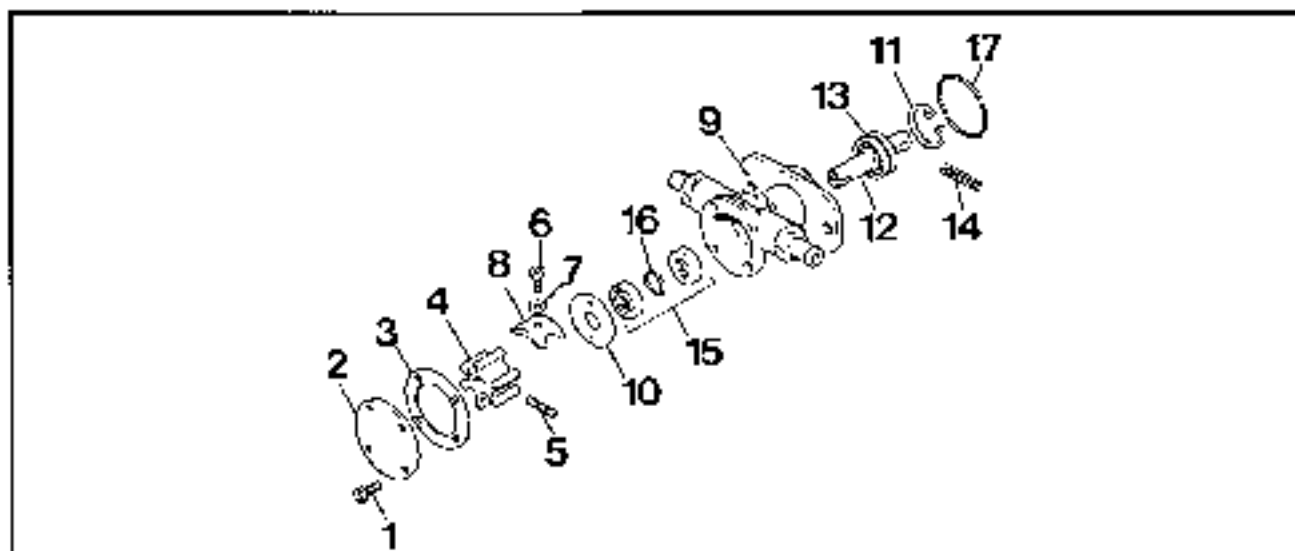

65

Screw out the four slotted-head screws (65/1) and remove the cover (65/2) and seal (65/3). Use two screwdrivers to press the impeller (65/4) out of the water pump, screw out the headless screw (65/5), screw out the slotted-head screw (65/6) and remove together with washer (65/7), take the cam (65/8) out of the pump housing (65/9). Take out the sealing plate (65/10). Disengage the circlip (65/11). Drive the shaft (65/12) complete with bearings (65/13) and slotted spring sleeve (65/14) rearwards out of the pump housing. Take the sealing rings (65/15) and O-ring (65/16) out of the pump housing.

Assembling the water pump

Note:

If necessary, the bearings (65/13), pump shaft (65/12) and slotted spring sleeve (65/14) are to be exchanged as a complete unit. Fit the sealing rings (65/15) and O-ring (65/16) into the pump housing. Fill the new bearings (65/13) with grease and press them on to the new shaft (65/12). Pay attention that the bearings are a distance of 2 mm from the end of the shaft. Fit the slotted spring sleeve (65/14) and install the shaft from the rear into the pump housing. In doing so, pay attention that the O-ring between the two sealing rings is not damaged. Adhere to the distance "A" = 2 mm, as shown in Fig. 66. Engage the circlip (65/11). Fit the sealing plate (65/10) and locate on pin. Fit the cam (65/8) into the pump housing, place the washer (65/7) on the slotted-head screw (65/6) and screw the cam tight.

Screw in the headless screw (65/5), position the vanes of the impeller (65/4) in the direction of rotation and push the impeller on to the pump shaft. Fit a new seal (65/3) (wide side facing cam), place the cover (65/2) in position and screw it tight with the four slotted-head screws (65/1).

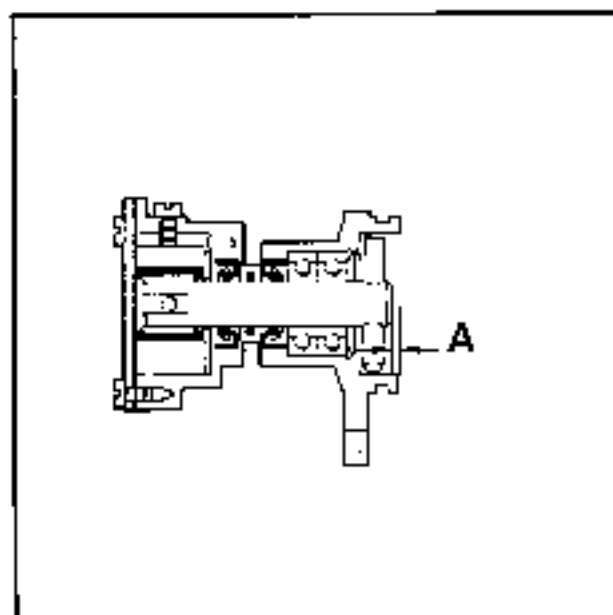

56

31

REMOVING AND INSTALLING THE ENGINE STOP MAGNET(only for version with electric motor stop as accessory)

Removing the engine stop magnet

Fig. 67

Loosen the clamping screw (67/1) and take off the cable (67/2). Screw out the three Phillips head screws (67/3) and remove the electromagnet for the engine stop from the holder (67/4).

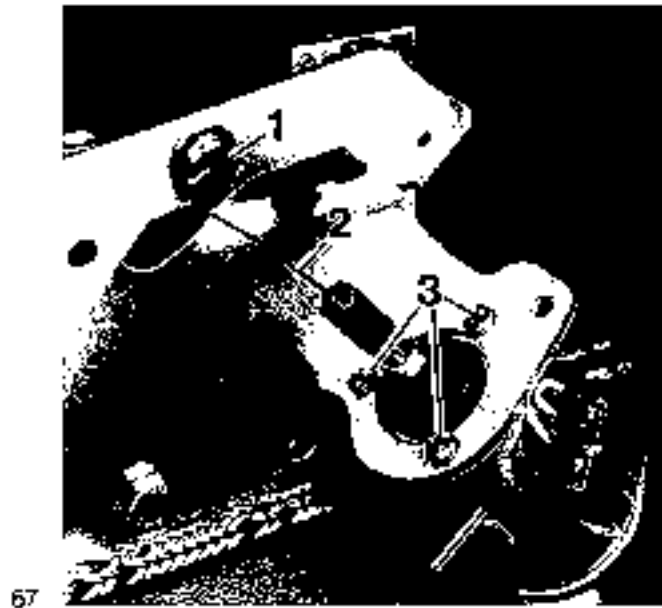
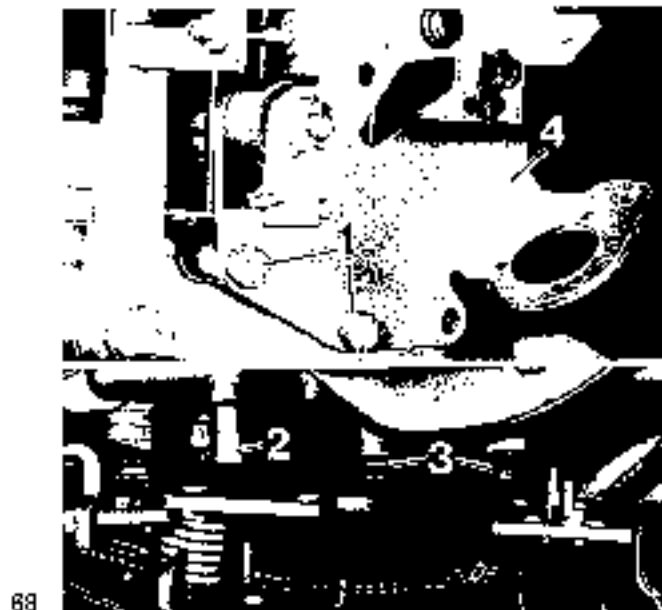

Fig. 68

Screw out the two hex.-head screws (68/1) and remove the spacer tube (68/2) and washers (68/3) together with the holder (68/4) from the engine.

Installing the engine stop magnet

Installation of the magnet takes place in the reverse sequence to removal.



REMOVING AND INSTALLING THE FUEL PUMP

Removing the fuel pump

Fig. 69

Screw out the two hex. head screws (69/1) and take the fuel pump (69/2) together with the seal (69/3) off the flange (69/4). Use a bar magnet to pull the pump tappet out of the flange.

Installing the fuel pump

Installation takes place in the reverse sequence to removal.

Note:

Use a new seal (69/3).

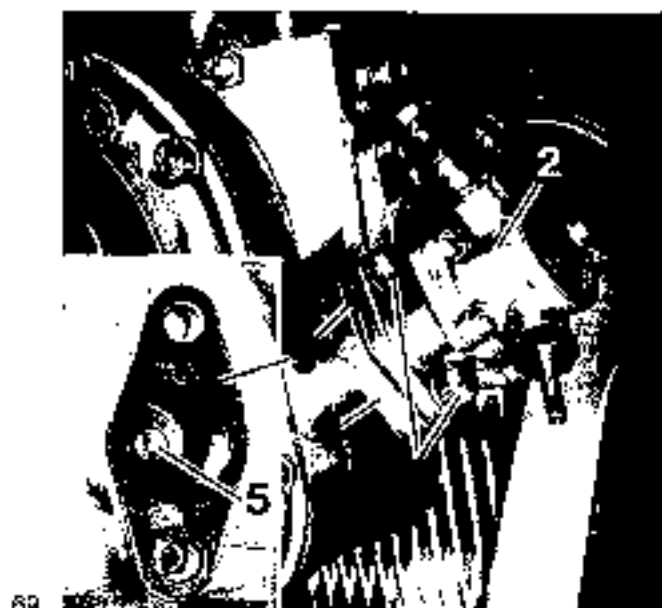

REMOVING AND INSTALLING THE TIMING COVER

Removing the timing cover

- Remove the water pump
- Remove the fuel pump

Fig. 70

Screw out the four socket-head screws (70/1) and take the crank-handle guide (70/2) out of the timing cover. Screw out the ten socket-head screws (70/3).

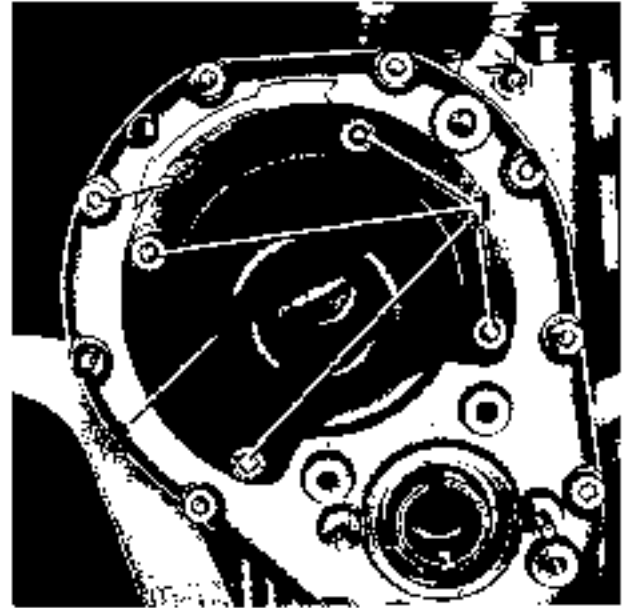

70

Fig. 71

Screw on the extractor, special tool No. 74 64 " 333 555, with two timing cover screws and press the timing cover off the intermediate ring (71/2). Remove the seal. Take the shaft seal (71/3) out of the timing cover.



71

Fig. 72

Examine the two bearings (72/1.2) for damage and exchange them, if necessary. For this purpose, heat the timing cover to approx. 80° C and take out the bearings.

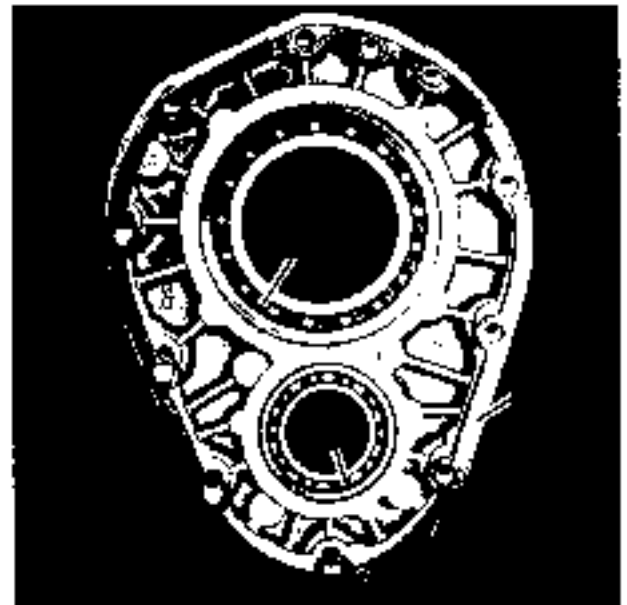

72

Installing the timing cover

Fig. 73

Apply the auxiliary bush, special tool No. 74 64 1 333 558 to the camshaft, fill the shaft seal (73/1) with grease between dust lip and sealing lip, so that the dust lip does not run dry. Place a new seal (72/3) on the timing cover and install the timing cover with light blows from a plastic hammer.

Complete installation of the timing cover in the reverse sequence to removal.

- Install the fuel pump
- Install the water pump

73

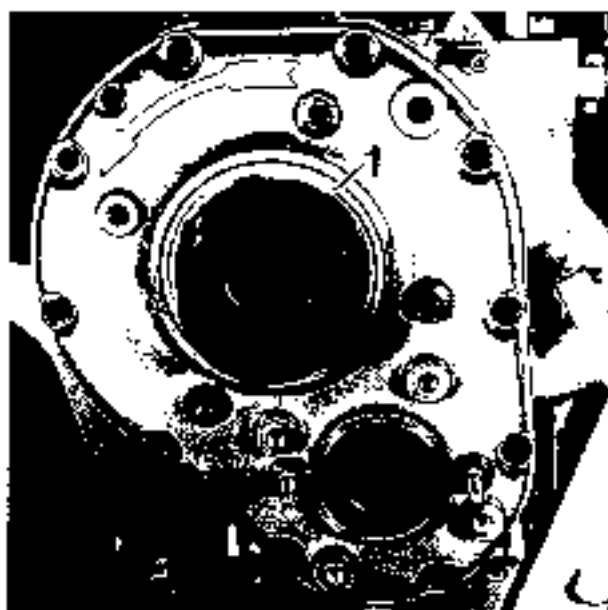

REMOVING AND INSTALLING THE INJECTION PUMP

Removing the injection pump

- Remove the fuel pump

Fig. 74

Shift the control lever to full load, do not pull the cold start knob.

Unscrew the three hex. nuts (74/1), pull the injection pump carefully out of the crankcase and remove it together with the seal and shims.

74

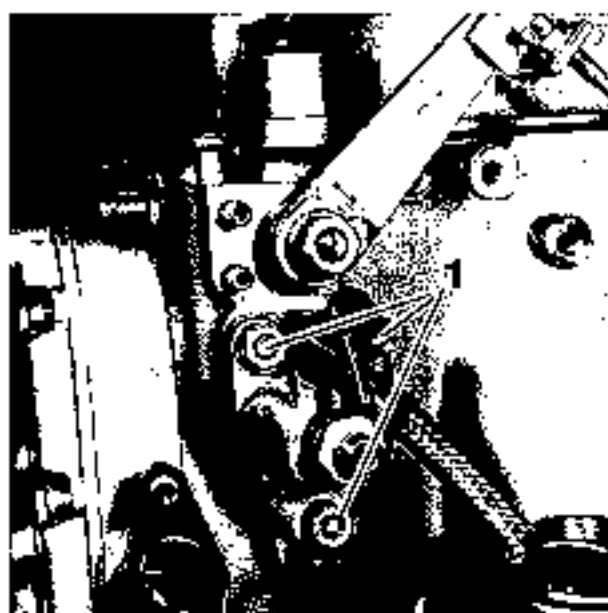

Installing the injection pump

Fig. 75

Turn the camshaft so that the base of the cam (lowest position) faces the injection pump opening. Place the seal (75/1), the shims (75/2) and the top seal (75/3) in position. Shift the control lever to full load, install the injection pump and screw it tight with the three hex. nuts.

- Install the fuel pump

75



SETTING THE INJECTION PUMP

Setting the end of delivery

Fig. 76

Screw out the delivery valve holder (76/1). Take the spring (76/2), sealing ring (76/3), valve cone (76/4) and valve piston (76/5) out of the injection pump.

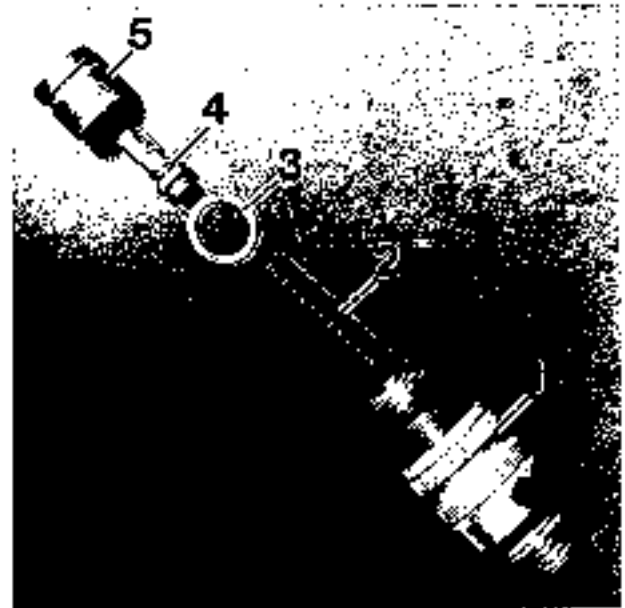

76

Fig. 77

Turn the engine until the pump piston has been brought into its lowest position. Screw in the spill device, special tool No. 74 64 1 333 535, and fit dial gauge, special tool No. 74 64 1 333 546, with a preload of approx. 1 mm. Shift the control lever to the "Start" position. Do not pull the cold start knob. Close the return bore at the barja bolt (77/1). Connect up a separate fuel line.



77

Fig. 78

Fuel must flow free of bubbles out of the overflow device.

Note:

The markings for T.D.C. (78/1) and the graduations (78/2) for the beginning of injection are punched in the flywheel.

The marking mark (78/3) is on the crankcase.



78

Use the flywheel to turn the engine in the direction of rotation (anticlockwise when looking at the flywheel), until the fuel ceases to flow out of the overflow device. Then continue to turn slowly until the fuel begins to flow out again. This point is the end of delivery. Check the number of degrees shown on the flywheel against the specified value = $10 \pm 0.5^\circ$. If the two figures do not tally, set the end of delivery as follows.

Set the dial gauge to "0" and turn the flywheel to the specified number of degrees. Read off the value indicated on the dial gauge. This value is the thickness of the shims which must be removed or added underneath the injection pump.

End of delivery later = add shims
 End of delivery earlier = remove shims

Remove the injection pump, correct the end of delivery with the shims (75/2) and install the injection pump again. To verify the setting, repeat the check once again.

Setting the effective stroke

Fig. 79

Once the end of delivery has been correctly set, the effective stroke must be checked and set.

Use the flywheel to set the injection pump on end of delivery. Set the dial gauge to "0".

Use the flywheel to turn the engine against the direction of rotation until the dial gauge shows 1.54 mm – specified value for the effective stroke. Fuel must now begin to flow out of the overflow pipe again. If not, set the effective stroke as follows:

Remove the sealing wire and screw out the headless screws (79/1). Use the special tool No. 74 04 1 323 528 to turn the cold start eccentric cautiously until fuel starts to emerge from the overflow pipe.

Tighten the headless screws again, check the effective stroke once more and seal the headless screws with wire against turning.

Take the dial gauge and the spill device off the injection pump. Fit the spring, sealing ring, valve cone and valve piston in the injection pump. Screw in the delivery valve holder (see Fig. 76).

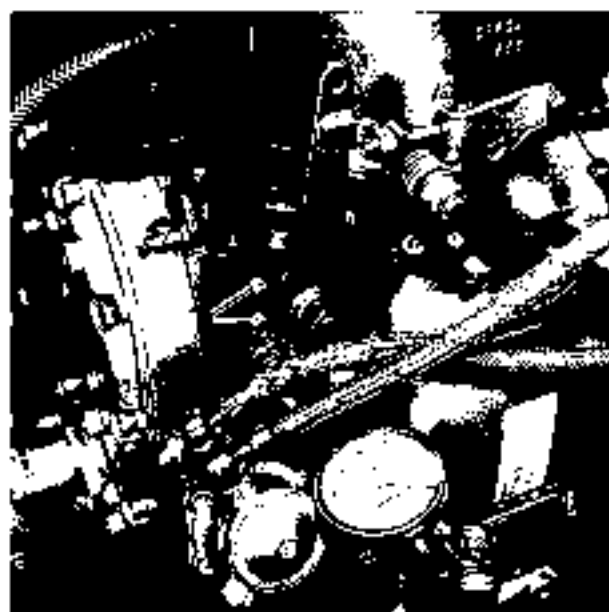

79

OVERHAULING THE INJECTOR NOZZLE

- Remove the injector nozzle (see "Removing the cylinder head")

Fig. 00

Unscrew the union nut (80/1). Take out the nozzle (80/2) and clean it with a nozzle cleaning tool. Under no circumstances must hard objects such as steel brushes, etc., be used for cleaning. The carbon residue attached to it is to be cleared off properly.

The nozzle is to be exchanged if:

the nozzle needle (80/3) is rough or corroded,
the nozzle needle or nozzle body has been overheated (blue discolouration),

there is leakage at the nozzle needle cone.

Flush all parts in clean fuel prior to assembly. Tighten the union nut with a tightening torque of 95 Nm.

90

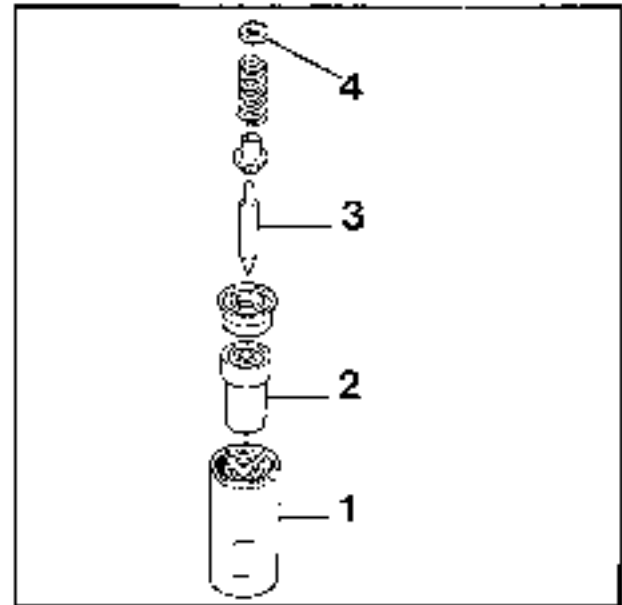
**Caution:**

The utmost care must be observed in cleaning and checking the nozzle. Flush the injector only in clean fuel. Even microscopically small particles lead to wear and to malfunctioning.

Note:

A defective nozzle leads, amongst other things, to poor combustion (dense, black exhaust smoke), poor performance and overheating of cylinder head, piston and cylinder.

CHECKING THE FUNCTIONING OF INJECTION PUMP AND INJECTOR

- Remove the high-pressure line
- Bleed the fuel system properly

Figs. 81 and 82

Shift the control lever to "Full load". Do not pull the cold start knob.

Connect up the pressure gauge, special tool No. 74 64 1 333 545, to the injection pump. The connections (81/1,2) must be closed.

Turn the engine over by hand until the pressure gauge indicates 300 to 350 bars. Stop turning and watch whether the pressure is maintained.

81

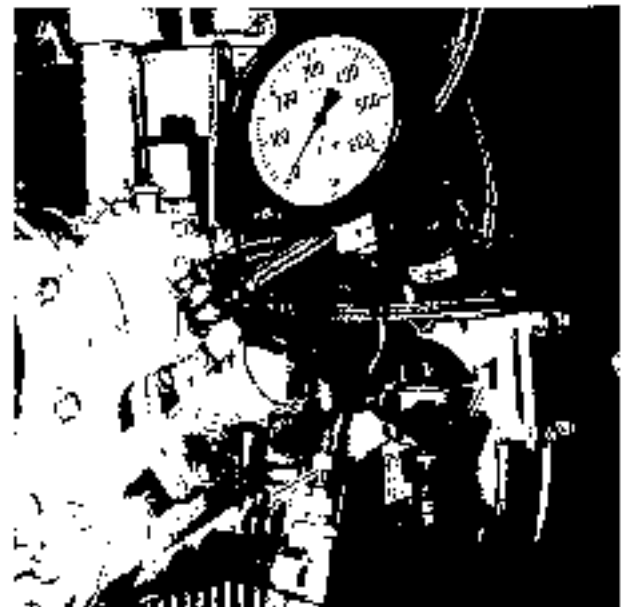

37

If the pressure drops and the pump does not even hold a pressure of 250 bars, it is defective.

To check the injector, connect it up to connection 1 or 2 of the pressure gauge. Turn the engine over by hand again. The ejection pressure and the functioning of the injector can be observed from the spray pattern. If the injector is in order, the spray pattern will be as illustrated in (82/1); if it is defective, as illustrated in (82/2).

The ejection pressure, specified pressure 112+8 bars, is altered by adding or removing small plates (82/4) on the injector spring.

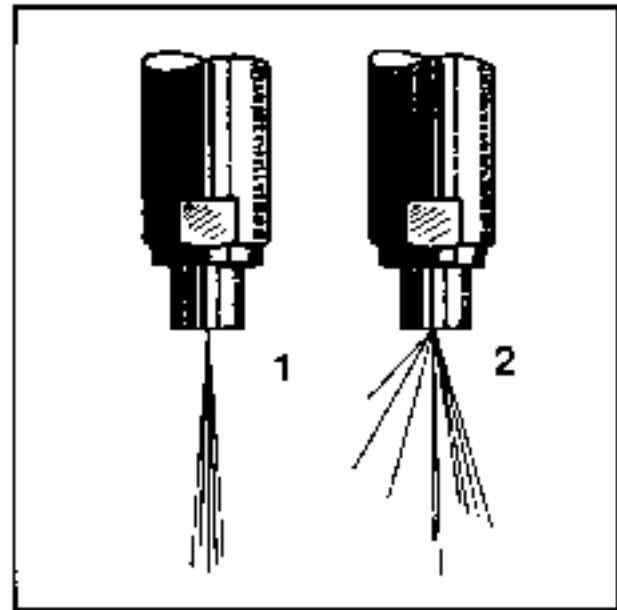

82

Warning:

Do not point the fuel jet at the body, danger of injury!

**REMOVING AND INSTALLING
THE CAMSHAFT ASSEMBLY**

Removing the camshaft assembly

Fig. 83

Turn the camshaft until the contrarotating counterweight (83/1) faces the crankshaft. Block the crankshaft to prevent it turning.

Fabricate a metal plate (83/2) as illustrated and screw it on to the crankshaft gear. Screw out the socket-head screw (83/3) and remove together with its lock washer. Apply a two-arm puller to the metal plate and pull the gear together with the driver (83/4) of the crankshaft.

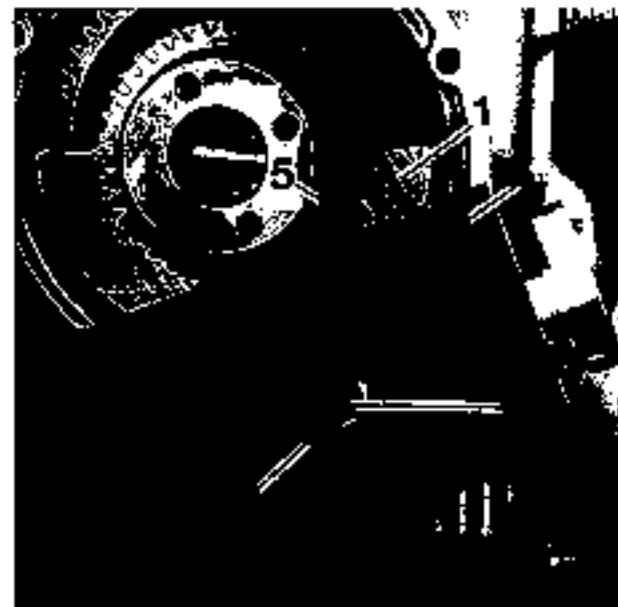

83

Fig. 84

Place the engine on its flywheel side. Lift both rocker levers upwards as far as they will go off the crankshaft, so that they are not damaged by the cam tips. Remove the ring (83/5) and use the extractor, special tool No. 74 64 1 333 556, to pull the complete camshaft assembly out of the crankcase. Remove the intermediate ring (84/1) together with the sec. from the crankcase.



84

Installing the crankshaft assembly

Installation of the camshaft assembly takes place in the reverse sequence to removal.

Fig. 85

Caution:
The marks (85/1) on the crankshaft and camshaft gears must coincide.



85

Caution:

Fig. 86

To install the gear (86/1), heat it to 80 – 100° C and install it so that the two marks (86/2) coincide. Push on the ring (87/9).

- Install the timing cover
- Install the water pump
- Install the fuel pump

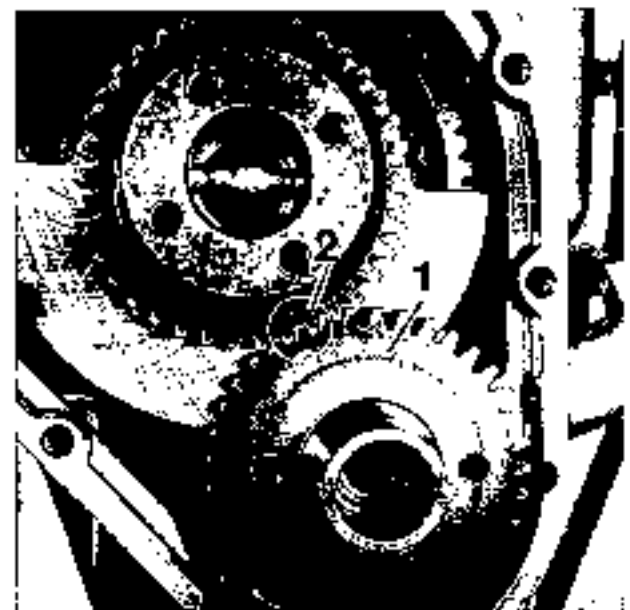

86

Stripping the camshaft assembly

Fig. 87

Put the cams (87/1,2), gear (87/3), spacer (87/4), gear (87/5) with counterweight and needle-bearing outer race, inner race (87/6) and spacer (87/7) singly, one after the other, from the camshaft (87/8).

Note:

If necessary, heat the inner race to approx. 70–80° C.

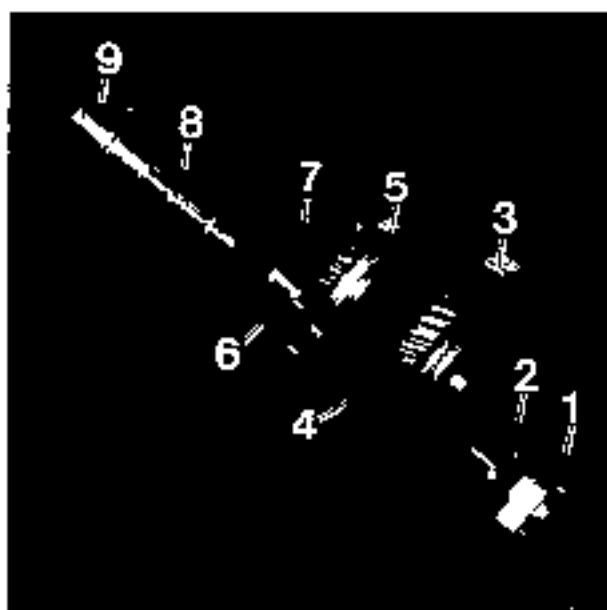

87

Assembling the camshaft assembly**Note:**

Push the spacer (87/7) and the inner race (87/6) on to the camshaft.

If necessary, exchange the needle-bearing outer race in the gear (87/5) and press the gear, with the counterweight facing rearwards, on to the camshaft. Place the spacer (87/4) in position and press the gear (87/3) on, with the "O" mark facing the counterweight. Press on the wide cam (exhaust) (87/2), with the chamfered side of the pole facing the gear. Press the narrow cam (intake) (87/1), with the recesses facing the exhaust cam, on to the camshaft.

REMOVING AND INSTALLING THE ROCKER LEVERS**Removing the rocker levers**

- Remove the camshaft assembly

Fig. 88

Screw out the socket-head screw (88/1) and take the rocker levers (88/2) together with the rocker lever bracket (88/3) out of the crankcase.



88

Fig. 89

Disengage the two circlips (89/1) and pull the rocker lever shaft (89/2) out of the rocker levers (89/3) and out of the rocker lever bracket (89/4). Pay attention to the shim(s) (89/5).

Examine the rocker levers for wear and exchange, if necessary.

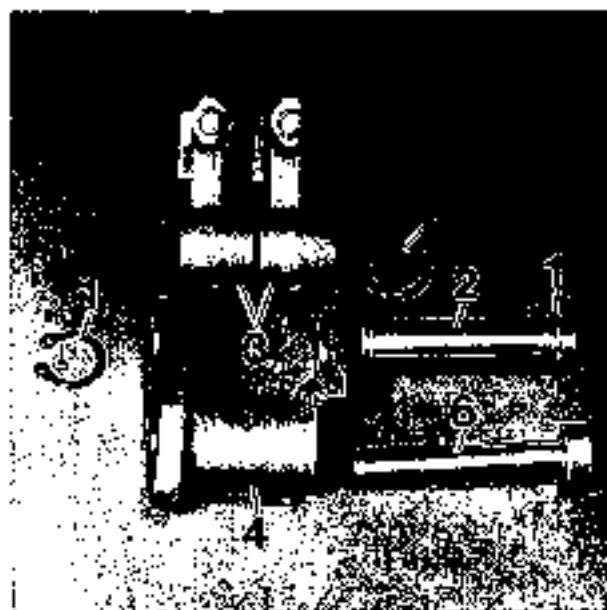

Installing the rocker levers

Installation takes place in the reverse sequence to removal.

Note:

Fit the rocker lever shaft with the longer ridge facing the crankcase.

Tighten the socket-head screw (89/6) with a tightening torque of 60 Nm.

- Install the camshaft assembly

REMOVING AND INSTALLING THE FUEL CONTROL SYSTEM

Removing the fuel control system

- Remove the camshaft assembly
- Remove the rocker levers

Fig. 90

Shift the control lever to the "Stop" position and remove the circlip (90/1) from the governor lever shaft.



Fig. 91

Use the extractor, special tool No. 74 64 1 333 554, to pull the governor lever shaft out of the governor lever (91/1) and out of the crankcase. Disengage the governor lever from the governor spring and take it out of the crankcase.



91

Fig. 92

Block the crankshaft. Use the extractor, special tool No. 74 64 1 333 527, to pull the crankshaft gear (92/1) off the crankshaft. Remove the sliding disc (92/2) and ball sleeve (92/3), paying attention to balls falling out of the ball hub.

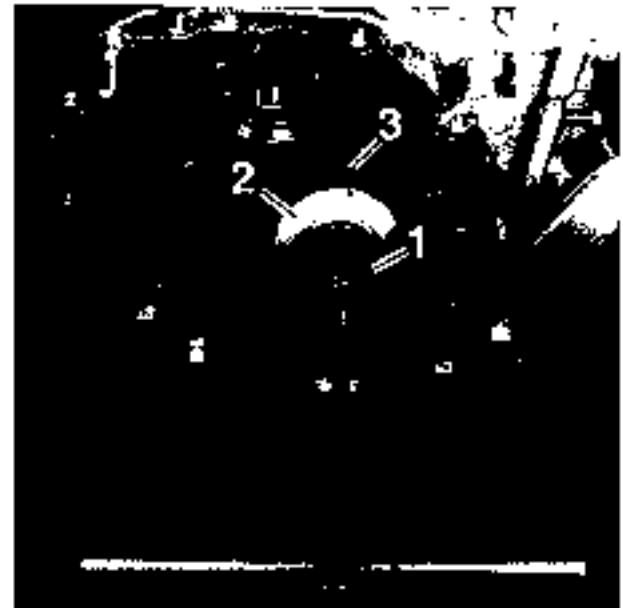

92

Fig. 93

Use the extractor, special tool No. 74 64 1 333 557, to pull the ball hub off the crankshaft.



93

Fig. 94

Unscrew the lock nut (94/1) and hex. nut (94/2) and take the washer (94/3) off the control lever shaft (94/4). Remove the control lever (94/5).



94

Fig. 95

Take the key (95/1) out of the shaft and remove the spacer (95/2). Sever the locking wire and screw out the speed adjusting screw (95/3). Knock the control lever shaft out of the crankcase.



95

Fig. 96

Remove the cotter pin (96/1) and take the spring (96/2) off the control lever shaft (96/3). Exchange the O-ring (96/4)

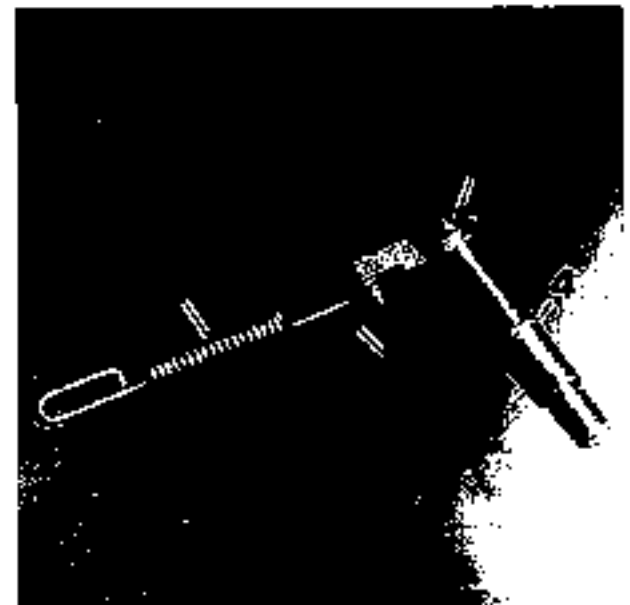

96

Fig. 97

Sever the locking wire, screw the headless screws out of the hoses (97/1) and use the special wrench, special tool No. 74 64 1 333 528, to screw out the cold start device (97/2).



97

Installing the fuel control system

Installation of the fuel control system takes place in the reverse sequence to removal.

Note:

Fig. 98

Heat both parts (98/1) of the ball hub to 70–80° C, place them on the crankshaft and use the mandrel, special tool No. 74 64 1 333 526, to drive them on the crankshaft as far as they will go.

Use some bearing grease to fit the four balls diagonally into the ball hub.

Push on the ball sleeve and sliding disc (see Fig. 92) and check that they slide properly.



98

Note:

Fig. 99

Heat the crankshaft gear to 80 to 100° C and use the mandrel, special tool No. 74 64 1 333 526 to drive it on to the crankshaft. Fit the driver.

- Install the camshaft assembly
- Install the rocker levers.

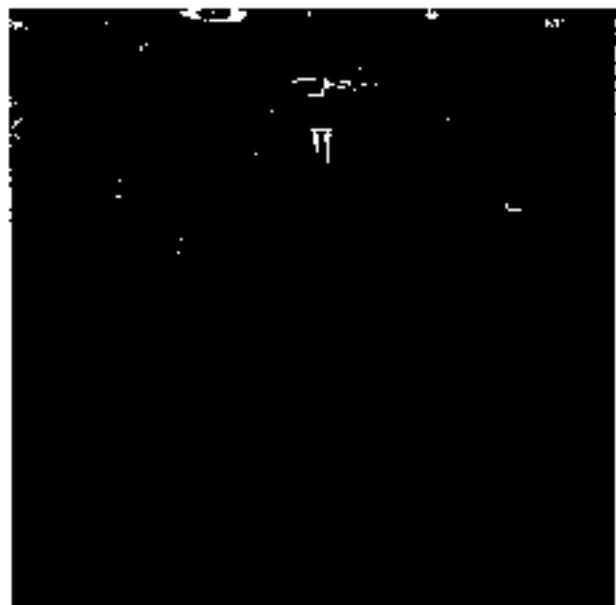

99

Setting the engine speed

Note:

A rev-counter is indispensable for setting and altering the engine rated speed.

Fig. 100

Unscrew the lock nut (100/1). Turn the headless screw (100/2) until the desired speed is obtained.

Turn clockwise to decrease the speed.
Turn anti-clockwise to increase the speed.

Screw the lock nut tight and seal it.

Caution:

The camshaft is geared down in the ratio of 1:4, i.e., the speed measured on the camshaft must be multiplied by 4 to obtain the engine rated speed.

100

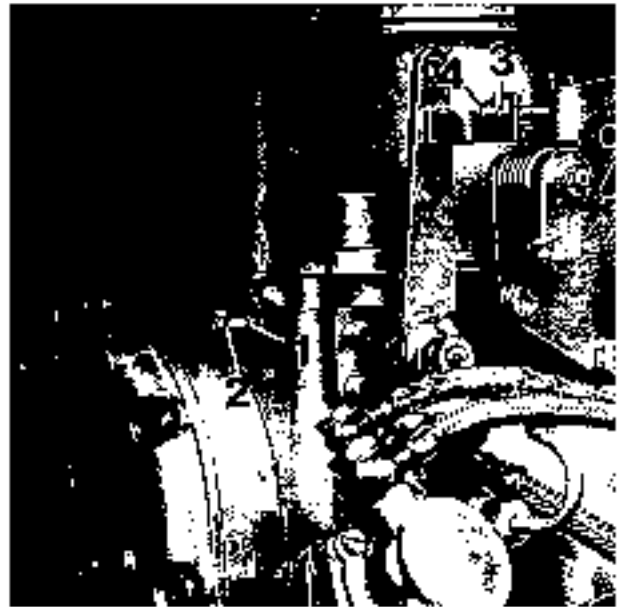

Note:

Every time the headless screw is shifted, the control lever must be shifted briefly in the direction of "Stop" and then brought into the full-load position up to the stop.

To obtain the desired rated speed at full load, the maximum speed of the unloaded engine must be set at 3160 r.p.m.

Setting the idling speed

Slacken the lock nut (100/3) and turn the headless screw (100/4) until the idling speed is 750 - 800 r.p.m. Tighten the lock nut again.

REMOVING AND INSTALLING THE PISTON

Removing the piston

Fig. 101

Bring the piston to T.D.C. and disengage the circlips (101/1).

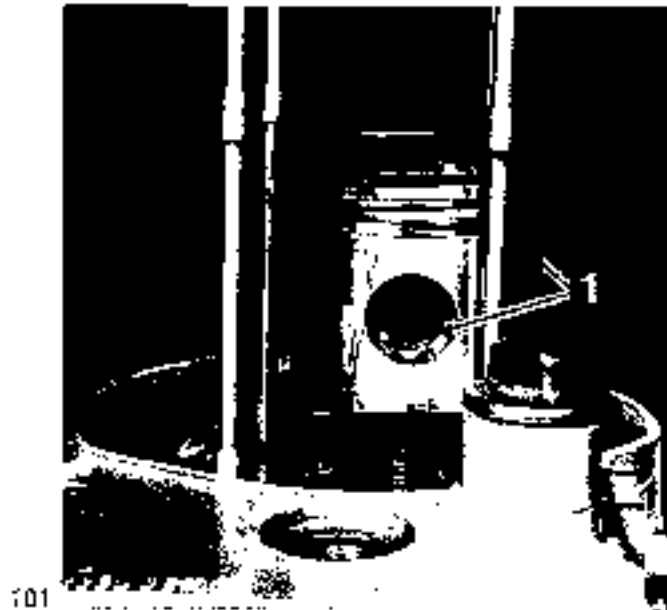

Fig. 102

Heat the piston to 50° C, use the extractor, special tool No. 74 64 1 333 552, to press the gudgeon pin out and remove the piston from the connecting rod.

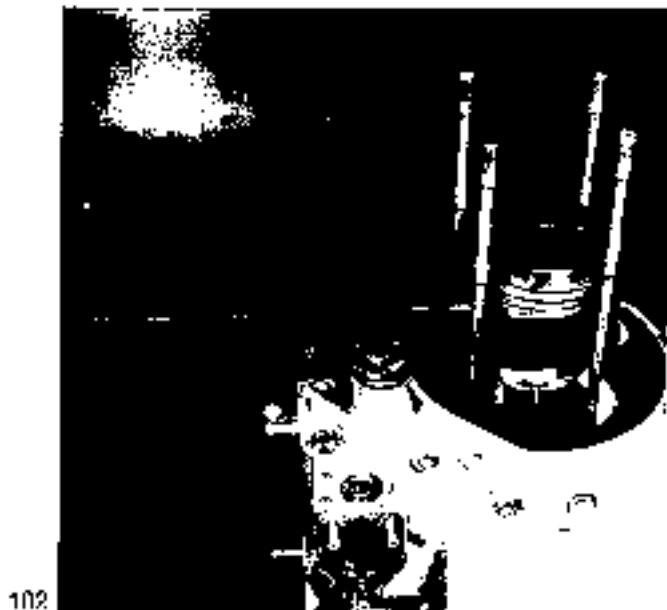

Fig. 103

Remove the piston rings from the piston with piston ring pliers, special tool No. 74 64 1 333 549. Examine the piston for damage such as ring land fracture, seizure sites, worn ring grooves, worn gudgeon-pin bores and exchange, if necessary.

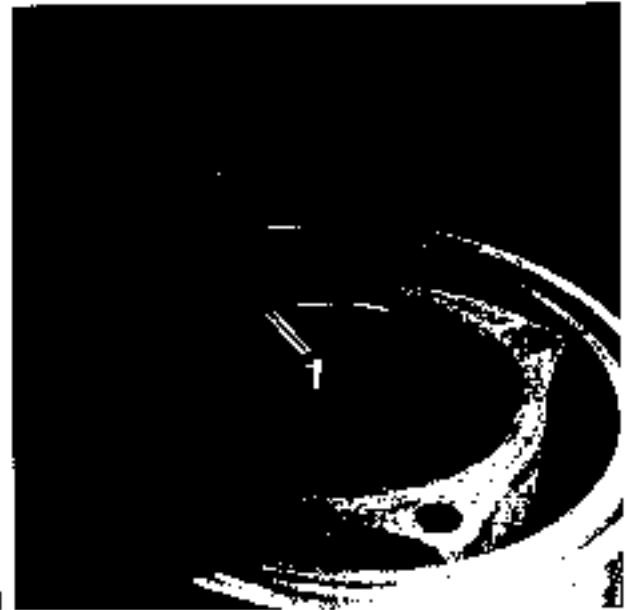

Fig. 104

Fit a piston ring (104/1) in the cylinder and measure the piston ring gap with a feeler gauge. Specified gap (new condition) 0,3 – 0,5 mm. Permissible wear up to 2,0 mm.

Carry out this measurement on all three piston rings, one after another.

104



Installing the piston

Installation of the piston takes place in the reverse sequence to removal.

Caution:

Fig. 105

The recess (105/1) in the piston top must face the flywheel side.

Note:

Before the gudgeon pin (105/2) is installed, fit a circlip in the piston as a stop.

- Install the cylinder
- Install the cylinder head

105



REMOVING AND INSTALLING THE CONNECTING ROD

Removing the connecting rod

Fig. 106

Place the engine on one of its sides. Screw out the four hex.-head screws (106/1), remove them together with their spring washers and take off the crankcase cover (106/2). Pull out the oil dipstick.

106



Fig. 107

Screw out the two socket-head screws (107/1), remove them together with their spring washers and take the counterweight (107/2) off the crankshaft.

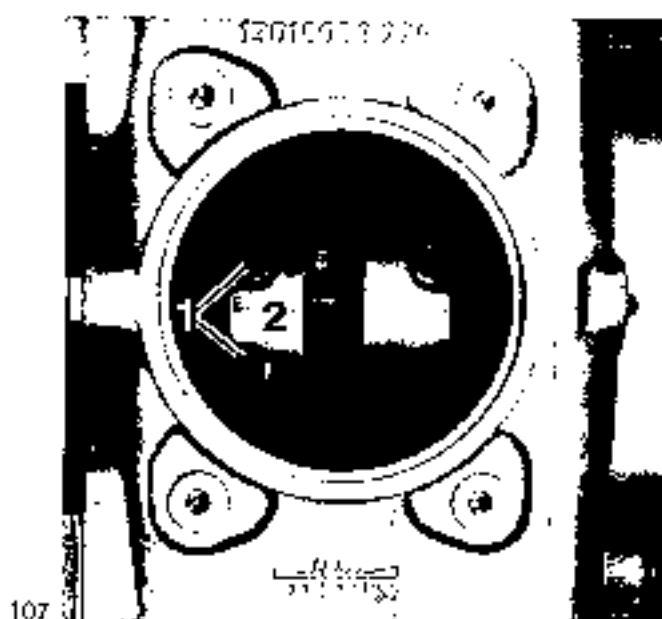
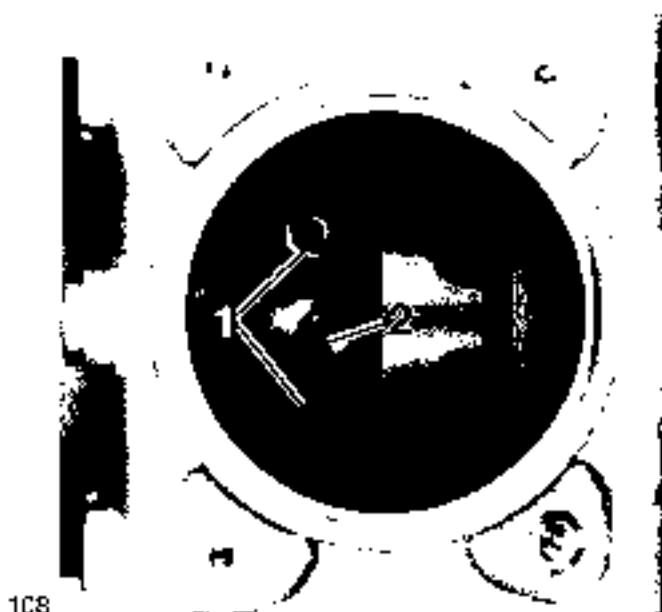

Fig. 108

Screw out the two socket-head screws (108/1), remove them together with their lock washers and take the connecting rod bearing cap (108/2) and connecting rod out of the crankcase.



Installing the connecting rod

Fig. 109

Installation of the connecting rod takes place in the reverse sequence to removal.

Prior to installation, check the connecting rod for the following damage and exchange, if necessary:

- overheating (blue discolouration)
- maximum slant
- connecting rod bearing wear
- connecting rod bearing roughness or cracks

Note:

The numbers (109/1) stamped in the connecting rod and in the connecting rod bearing cup must face the same side. The scoop opening (109/2) must face in the direction of rotation of the engine. Place a new O-ring on the crankcase cover.

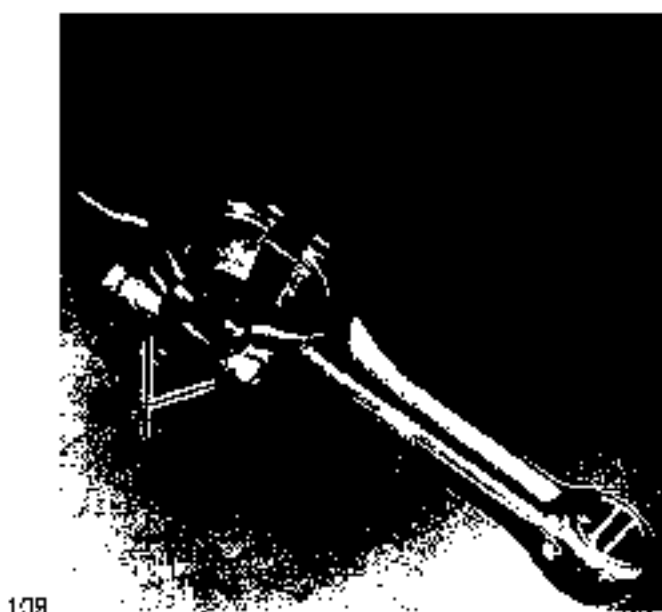

REMOVING AND INSTALLING THE CRANKSHAFT

Removing the crankshaft

- Remove the connecting rod

Fig. 110

Remove the second counterweight (see Fig. 107). Place the engine upright again and take the crankshaft out of the crankcase, if necessary using a plastic hammer to drive it out. Disengage the snap ring (110/1) and press out the outer race (110/2) of the cylindrical roller bearing. Heat the crankcase to approx. 80° C and pull out the camshaft bearing (110/3) with the internal extractor, special tool No. 74 64 1 333 530.

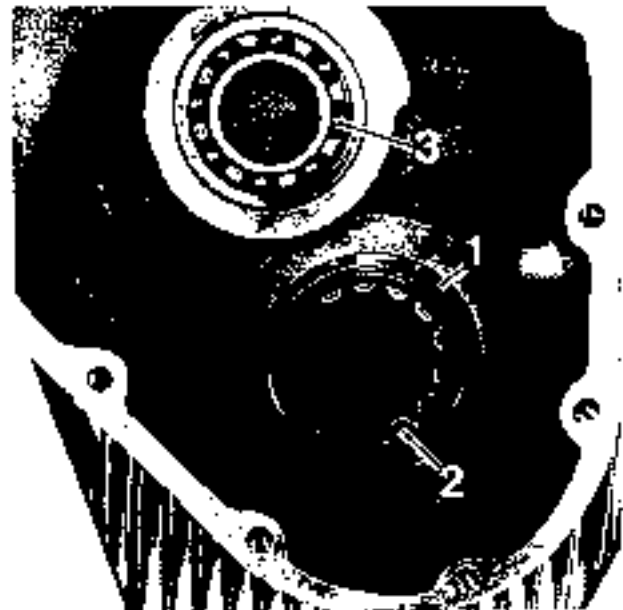

110

Fig. 111

Remove the shim (111/1), heat the two inner races (111/2) to approx. 90–100° C and take them off the crankshaft.

Note:

Heat the inner races with a medium-size welding torch to avoid heat being transferred to the crankshaft. Pay attention that the races are not overheated (blue discolouration). Under no circumstances must damaged races be re-used.

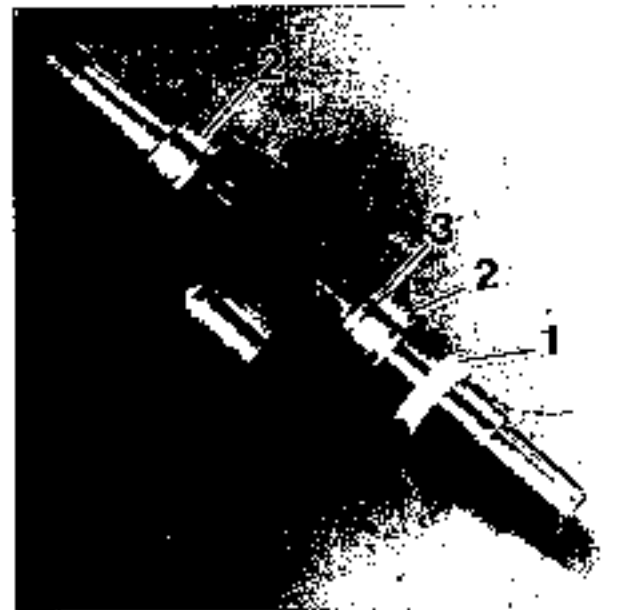

111

Installing the crankshaft

Installation of the crankshaft takes place in the reverse sequence to removal.

Fig. 112

To install the crankshaft, heat the crankcase to approx. 80–100° C.

Measure the distance "H" from the seat of the bearing flange to the contact face of the flywheel-side inner race and correct with shims (111/3), if necessary. Specified distance, crankcase cold: 15,1 – + 0,3 mm; crankcase warm: 15,3–15,5 mm.

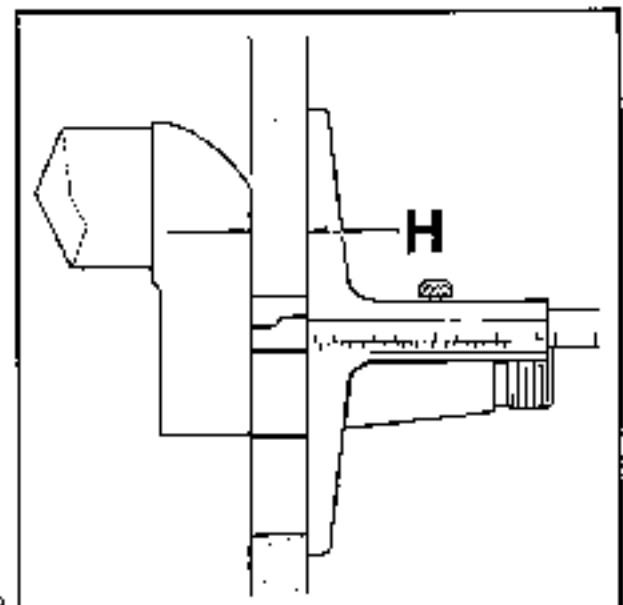

112

- Install the bearing cover and measure the crankshaft end clearance. Specified end clearance with crankcase cold: 0,1 - 0,3 mm; with crankcase warm: 0,3 - 0,5 mm.

Fit the large counterweight on the flywheel side. Tighten the socket-head screws of the counterweights with a tightening torque of 65 Nm.

JOB SEQUENCE IN ASSEMBLING THE ENGINE

- Install the crankshaft
- Fit the bearing cover
- Measure the crankshaft end clearance
- Install the fuel control system
- Install the connecting rod
- Install the counterweights
- Install the piston
- Fit the crankshaft gear
- Install the rocker levers
- Install the camshaft assembly
- Fit the timing cover
- Fit the hand-crank guide
- Install the cylinder
- Measure the piston projection
- Fit the valves
- Install the decompression lever
- Fit the rocker arms
- Fit the cylinder head
- Set the valve clearance
- Set the decompression device
- Install the injector
- Fit the temperature pickup
- Fit the thermostat
- Install the exhaust manifold
- Install the water pump
- Install the injection pump
- Install the fuel pump
- (With electric engine stop as accessory) install the electric engine stop
- Install the air filter
- Install the stator
- Fit the flywheel housing ring
- Install the flywheel with rotor
- Install the clutch
- Install the gearbox
- Install the retaining plate with engine electricals
- Install the starter
- Set the injection pump

TECHNICAL DATA AND SPECIFICATIONS

SPECIFICATIONS

Fuel	Dieso DIN 51601
Engine oil	HD-API CC/CD
Gearbox oil	Hirth ATF Dexron / ZF SAE 20 W 20
Fuel filter	BMW 13 32 1 329 270
Air filter	BMW 13 71 1 329 269
Gearbox	Hirth H&W 5 or ZF BW 3

TECHNICAL DATA

Engine

No. of strokes	4-stroke
Cycle	Diesel cycle with direct injection
No. of cylinders	1
Displacement c.c.	629
Stroke mm	100
Bore mm	82
Compression ratio	22:1
Output KW (metric horsepower)	7,5 (10) at 3700 r.p.m.
Max. torque	27 Nm at 1900 r.p.m.
Lubrication	splash
Cooling	single-circuit water cooling
Engine weight, dry, with gearbox <g>	138

Filling quantities

Engine oil	2 litres
Gearbox oil	0,4 litres
Max. axial installation angle	15°
Gearbox reduction ratio	forwards 2,7:1, reverse 1,8:1

Piston

Piston dia.	81,97 mm
Oversize	+1 mm
Piston ring gap, new	0,3-0,5 mm
Piston ring gap, max. after wear	2 mm
Piston projection from top edge of cylinder	0,80-0,90 mm

Connecting rod

Gudgeon pin bore dia.	32H6 ^{+0,016} mm
Connecting rod bearing bore dia.	54 ^{+0,019} mm
Gudgeon pin bush outer dia., loose	32s6 ^{-0,029} mm
Gudgeon pin bush inner dia., pressed in	26E8 ^{-0,027} mm
Max. wear	0,20 mm
Max. permissible slant	0,08 mm over measuring length of 300 mm

Connecting-rod bearing

Outer dia.	54 mm
Inner dia.	48 mm
Width	32 ^{+0,2} mm
Undersize	47,5 mm

Cylinder head and valves

Thickness of cylinder head gasket	1,50 mm
Rocker arm shaft dia.	12 ^{+0,03} _{-0,04} mm
Max. wear	0,05 mm
End clearance	0,05 mm
Rocker arm bore dia.	12K7 ^{+0,03} _{-0,02} mm

Max. wear	0,05 mm
Radius on rocker arm	8 mm
Valve seat angle	45°
Valve clearance, cold	0,35 mm
Valve stem dia. Intake	7 ^{+0,02} _{-0,04} mm

Exhaust	7 ^{+0,02} _{-0,04} mm
---------	--

Valve disc dia. Intake	31 mm
Exhaust	31 mm

Valve projection	
Max.	0,55 mm
Min.	0,25 mm

Valve guide	
Bore dia.	7H6 ^{+0,009} mm
Max. wear	0,05 mm
Outer dia.	12e5 ^{+0,026} _{-0,028} mm

Valve guide bore in cylinder head	12H8 ^{+0,011} mm
Pressure for installing valve guide (cylinder head cold)	1000 N

Cylinder

Bore dia.	82 ^{+0,01} mm
Max. wear	0,15 mm
Permissible roughness	1,0–1,2 microns
Oversize	+1 mm
Shims available	0,1 and 0,2 mm
Piston projection	0,80–0,90 mm

Crankshaft

Crankpin dia. Standard	48 ^{+0,005} _{-0,000} mm
Overall clearance	0,15 mm
Undersize	47,5 ^{+0,005} _{-0,005} mm
Perm. single roughness	0,3 microns
Radii on crankpin	3,5 mm
Hardness of crankpin	50-55 RC
Depth of hardness on crankpin	1,1-1,5 mm
Bal. hub d.s.	29 ^{+0,001} _{-0,008} mm
Bal. sleeve dia.	28 ^{+0,000} _{-0,001} mm
Diameter of gear on crankshaft	22 ^{+0,005} _{-0,005} mm
Regind of crankpin	0,5 mm
Crankshaft end clearance	
With engine cold	0,1-0,3 mm
With engine warm	0,3-0,5 mm

Injection pump

Type	Bosch PFR 1X 70A/S43/1
Injection timing	
End of delivery	10±0,5° B.T.D.C.
Effective stroke	1,54 mm

Injector Bosch

Injection pressure 132⁺⁶ bars

Electricals

Starter (Bosch) sliding gear
Voltage 12 V
Output 1,1 kW

Generator
Voltage 14 V
Max. current 25 A
Output 350 W

Battery 12 V 60 Ah

TIGHTENING TORQUES

Cylinder head nuts	55 Nm
Connecting rod bolts	60 Nm
Socket-head screws for counterweights (crankshaft)	65 Nm
Injector nuts	15 Nm
Nozzle holder	15 Nm
Flywheel nut	250–300 Nm
Injection-pump delivery valve	40 Nm
Bearing flange nuts (on flywheel side)	30 Nm
Union nut on injector	65 Nm
Rocker lever bracket screw	60 Nm
M 12 × 1,5 screw in end of crankshaft on timing gear side	60 Nm

SPECIAL TOOLS

Description	BMW Part No.
Mandrel for ball hub	74 64 1 333 525
Mandrel for crankshaft gear	74 64 1 333 526
Extractor for crankshaft gear	74 64 1 333 527
Spill device for injection pump	74 64 1 333 535
Wrench for cold-start device	74 64 1 333 528
Multi-purpose extractor	74 64 1 333 536
Wrench for multiple plug, synchro	74 64 1 333 529
Allen socket, 8 mm, with pilot	74 64 1 333 537
Allen socket, 10 mm, with pilot	74 64 1 333 538
Clamp for valve grinding	74 64 1 333 539
Allen wrench, 8 mm, long	74 64 1 333 540
Allen socket, 6 mm	74 64 1 333 541
Bracket for cylinder	74 64 1 333 581
Press-in mandrel, 7 mm dia., for valve guide	74 64 1 333 542
Hand reamer, 7 mm dia., H 7 for valve guide	74 64 1 333 532
Piston ring strap	74 64 1 333 560
Measuring device for piston projection	74 64 1 333 544
Testing device for injection equipment	74 64 1 333 545
Dial gauge 1/100 mm	74 64 1 333 546
Torque wrench 0–140 Nm	74 64 1 333 547
Guide for valve reseating tool, 7 mm	74 64 1 333 534
Holder for valve reseating tool	74 64 1 333 548
Piston ring pliers	74 64 1 333 549
Allen socket, 8 mm	74 64 1 333 550
Valve reseating tool, 42,5 mm dia.	74 64 1 333 551
Gudgeon pin extractor	74 64 1 333 552
Timing cover extractor	74 64 1 333 555
Extractor for governor hub	74 64 1 333 557
Extractor for camshaft	74 64 1 333 558
Auxiliary bush for installing timing cover on camshaft	74 64 1 333 558
Socket wrench for SW 48 flywheel nut	74 64 1 333 559
Allen socket, 10 mm, without pilot	74 64 1 333 582
Extractor for governor lever shaft	74 64 1 333 554
Internal extractor, 27–36 mm	74 64 1 333 590
Double-end flare nut wrench, 17/18 mm	74 64 1 333 543
Forcing screw	74 64 1 333 568

WINTER LAY-UP AND LENGTHY OPERATING BREAKS

The engine must be given preservation treatment for lengthy lay-ups, to prevent its components being destroyed by corrosion.

Before the boat is taken out of the water

- Run engine warm and drain oil with the engine at a standstill.
- Pour in corrosion inhibiting oil UNTIL LEVEL REACHES BOTTOM MARK on oil dipstick.
- Drain gearbox and fill up with oil. (See "Specifications");

Caution:

Before the engine is recommissioned, the corrosion inhibiting oil must be replaced by the recommended engine oil. It is expedient to hang an appropriate tag on the engine as a reminder.

- Mix 2 litres of Diesel fuel with 1 litre of corrosion inhibiting oil in a suitable container. Route a hose from the fuel line, or direct from the fuel filter, into this container.
- Start engine and run for about 15 minutes.

On dry land

- Drain water from the cooling system. Do not remove the water pump impeller.
- Close the raw water cock and detach the water pipe from the pump.
- Mix approx. 12 litres of clean water with approx. 1,2 litres of emulsifying corrosion inhibiting oil in a container. Continually mix oil with water and stir as thoroughly as possible.
- Connect a hose to the cooling water pump and hang the other end into the container.
- Start the engine (idling) to let the mixture circulate.
- Completely empty the cooling system. No residual water must remain in the engine, as the mixture used has no antifreeze properties.
- Shut off the engine.
- Unscrew the injector and pour about 1 teaspoonful of corrosion inhibiting oil into the cylinder. Crank the engine several times. Install the injector.
- Remove the water-pump impeller.
- Clean engine and gearbox and treat with corrosion inhibiting oil to protect from corrosion damage.
- Lubricate all cables and linkages.
- Disconnect the battery

Preparations for recommissioning

- Drain corrosion inhibiting oil and fill up with recommended oil.
 - Install impeller in the cooling water pump.
 - Unscrew fuel injector and crank engine several times to remove surplus oil from the cylinder.
 - Renew fuel filter.
 - Fill tank with fresh Diesel fuel. Old fuel should not be used. Check lines and connections.
 - Connect up battery again.
 - Start the engine, as soon as the boat is in the water.
 - Do not forget to open the raw water cock!
- Check fuel and cooling system for leakages.



1283
JW Marine GmbH
Grafen, West Germany
Subject to change in design and equipment
without notice or liability only with written
approval of BMW Marine GmbH
Subsidiary of Aerometallic Legale GmbH

Printed in West Germany
1283
31 2 128 1 62