



IMPORTANT INFORMATION

When working on the engine, for example adjusting drive belts, changing the oil or adjusting the clutch, it is important not to start the engine. The engine may be damaged and there is a

SERIOUS RISK OF INJURY

For this reason, always secure the starting device or disconnect a battery cable before working on the engine.

This is especially important if the engine has a remote starter or automatic starting.

This warning symbol and text is reproduced beside those inspection points where the risk of injury is particularly great.



Operator's Manual

DI16

EMS with S6/PDE

Marine engine

opm_d16mar_en-GB 2 291 675

COMMISSIONING REPORT - WARRANTY

When the start-up report has been filled in and sent to Scania, you have a 1-year warranty from the date of entry into service.

Also fill in the particulars below as this can make things easier if you need to contact a workshop for example.

Engine serial number

.....

Date of entry into service

.....

Power class, see page 5

.....

User's name and address

.....

.....

.....

Signature

.....

Engine type

.....

Variant

.....

Engine type and variant are indicated on the engine type plate

Preface

This Operator's Manual describes the handling and maintenance of Scania DI16 marine engines with EMS S6/PDE injection system.

The four stroke V8 diesel engines have direct-injection and are liquid-cooled. The engines are turbocharged and equipped with a charge air cooler which is coolant-cooled.

The engines can have 2 different cooling systems: a heat exchanger which is cooled by sea water, or keel cooling which has cooling coils on the hull in which the engine coolant is cooled.

Common areas of usage include forward propulsion engines in small boats like fishing boats and ferries, and in larger pleasure crafts, or as auxiliary engines on-board ships.

The engines can have different output and speed settings and are classified into different categories by classification societies (classified engines must be used in certain marine installations).

The normal output setting of the engine (performance code) is indicated on the type plate, see page 10.

Note: Only standard components are described in the operator's manual. Scania recommends that you consult the manufacturer's instructions with regard to special equipment.

In order to obtain the best value and service life from your engine, there are several points you should bear in mind:

- Read the Operator's Manual before starting to use the engine. Even though you may have experience of Scania engines you may find new information in this Operator's Manual.
- Follow the maintenance instructions. Good working order and service life are ensured if maintenance is carried out according to the instructions.
- In particular, read the safety information starting on page 6.
- Get to know your engine so that you know what it can do and how it works.
- If necessary, contact an authorised Scania workshop. They have special tools, genuine Scania parts and staff with training and practical experience of Scania engines.

Note: Always use genuine Scania parts during inspection and repair so as to keep your engine in the best possible working order.

The information in this manual was correct at the time of going to press. However, Scania reserves the right to make alterations without prior notice.



Important

See page 5 for information about the power classification.



Help protect our environment!

During the warranty period, only genuine Scania parts may be used during inspection and repair; otherwise the warranty will be invalidated.

Contents

Preface	2	Checking the sea water pump impeller	32
Contents	3	Checking the coolant	33
Environmental responsibility	4	Cleaning the cooling system	36
Certified engines	4		
Power classes	5	Air cleaner	40
Safety information	6	Checking the read-out from the vacuum indicator	40
Type designations	10	Cleaning or renewing the filter element	40
EMS engine management system	12	Fuel system	42
Location of sensors for EMS with S6 on DI16	13	Checking the fuel level	42
Troubleshooting using flash codes for the EMS control unit	14	Renewing the fuel filter	42
Reading off control unit fault codes	14	Electrical system	44
Clearing fault codes	14	Checking the electrolyte level in batteries ...	44
Overview of flash codes for the EMS control unit	15	Checking the state of charge in batteries.....	44
Troubleshooting using flash codes for the EMS coordinator	16	Cleaning the batteries	44
Reading off coordinator fault codes	16	Renewing the battery	45
Clearing fault codes	16	Checking the coolant level monitor	45
Overview of flash codes for the EMS coordinator	17	Miscellaneous	46
Starting and running	18	Checking the drive belt	46
First start	18	Check for leaks, rectify as necessary	47
Checks before running	19	Checking and adjusting the valve clearance	48
Starting the engine	19	Checking and adjusting the unit injector rocker arms	48
Running	20	Preparing the engine for storage	51
Stopping the engine	23	Technical data	54
Checks after running	23	Fuel	56
Maintenance	24	EC declaration of conformity	58
Engines with few hours of operation	24	Alphabetical index	59
Inspection schedule	25	Scania Assistance	60
Lubrication system	26		
Oil grade	26		
Checking the oil level	27		
Oil change	27		
Cleaning the centrifugal oil cleaner	28		
Renewing the oil filter	30		
Renewing the closed crankcase ventilation filter	31		
Cooling system	31		
Checking the coolant level	31		
Checking the sacrificial anodes	32		

Environmental responsibility

Scania has always been very much at the leading edge when it comes to developing and producing engines which are as environmentally friendly as possible.

Major progress has been made on reducing harmful exhaust emissions in order to comply with the stringent environmental requirements in force on almost all markets.

At the same time, we have been able to maintain high quality in terms of performance and operating economy for Scania Industrial and Marine Engines.

To preserve this quality level throughout the entire service life of the engine, it is important for the operator/owner to follow the instructions on running, maintenance and the choice of fuel and lubricating oil as outlined in the Operator's Manual.

Other efforts to preserve the environment we all share are possible by ensuring that the person carrying out inspection and maintenance always makes sure that environmentally hazardous waste after inspection and repairs (oil, fuel, coolant, filters, batteries, etc.) is dealt with and disposed of in accordance with applicable environmental requirements.

On a number of pages, this Operator's Manual contains specially highlighted text with instructions to help protect our environment during certain inspection and maintenance work.

See example



Help protect our environment!

Use a container to avoid spills when bleeding and renewing components.

Certified engines

Emissions-certified engines have been approved in accordance with a special certification standard. The certified engines supplied by Scania meet the most stringent emissions requirements which apply on European (EU) and non-European (USA) markets.

Scania guarantees that all the engines it supplies of a certified type are equivalent to the engine approved for certification.

The engine comes with a special certification plate which indicates the certification rules (standard) to which the engine has been approved. See page 10.

The following are required for the certified engine to fulfil the emissions requirements once it has been taken into service:

- Inspection and maintenance must be carried out in accordance with the instructions in this Operator's Manual.
- Only genuine Scania parts are to be used.
- The inspection of injection equipment must be carried out by an authorised Scania workshop.
- The engine may only be modified with equipment that has been approved by Scania.
- Seals may be broken and setting data edited only once approval has been granted by Scania in Södertälje. Modifications may be made by authorised personnel only.

- Changes which affect the exhaust system and intake system must be approved by Scania.

Otherwise, the instructions in the Operator's Manual in respect of running, care and maintenance of the engine shall apply. The safety precautions described over the next 4 pages must also be observed.

Important! *If inspection and maintenance are not carried out as specified above, Scania can no longer guarantee that the engine will comply with the certified design, nor can it take responsibility for any damage that occurs.*

Power classes

Scania supplies engines in 4 different power classes:

ICFN – Continuous operation: Unlimited number of operational hours per year at a total load factor of 100%.

IFN – Periodic operation: Intended for periodic operation where full power is available 1h/3h. The accumulated load factor must not exceed 80% of the calculated load. Unlimited number of hours per year.

Patrol craft – long: Intended for periodic operation where full power is available 1h/6h. In between periods of operation at full load, the engine speed must be reduced by at least 10% of the maximum engine speed attained. The maximum accumulated operating time must be 2,000 hours per year.

Patrol craft – short: Intended for periodic operation where the calculated power is available 1h/12h. In between periods of operation at full load, the engine speed must be reduced by at least 10% of the maximum engine speed attained. The maximum accumulated operating time must be 1,200 hours per year.

Below is a list of engine serial numbers and power classes for the engines that are used in this installation:

Engine serial number:

Engine type:

Engine power:.....kW, atrpm

Indicate below the type of operation, and enter it on page 1.

- ICFN – Continuous operation**
- IFN – Periodic operation:**
- Patrol craft – long**
- Patrol craft – short**

Safety information

General

This Operator's Manual contains safety information which is important so as to avoid both personal injury and damage to the product/other property. See also page 1.

The text highlighted in text boxes on the right of a number of pages is important for engine function and in order to avoid damage to the engine. If these instructions are not followed, the warranty may be invalidated.

See example. →

!

Important

Use only genuine Scania fuel filters.

Similar text may also appear in the text column, and in this instance it will be marked **Note:** or **Important.**

The warning text found in text boxes on the right of a number of pages which is marked with a warning triangle and starts with **WARNING** is extremely important and warns you of serious engine faults or incorrect handling which may lead to injury.

See example →



WARNING

Block the starting device when working on the engine. If the engine starts unexpectedly, there is a SERIOUS RISK OF INJURY.

A list of the safety precautions to be followed when running and maintaining Scania engines can be found on the next 3 pages. Similar text can often be found at the relevant maintenance points, and here different levels of importance are attached to such text in accordance with the above description.

All points are marked **!**, so as to indicate how important it is to read through each point in this section.

For safety reasons, smoking is prohibited:

- In the vicinity of the engine and in the engine compartment
- When refuelling and in the vicinity of the filling station
- When working on the fuel system
- In the vicinity of flammable or explosive material (fuel, oils, batteries, chemicals, etc.).

Safety precautions for running the engine

! Daily inspection

Always visually inspect the engine and engine compartment before starting the engine and once you have stopped the engine after running.

This will enable you to easily detect fuel, oil or coolant leaks, or any other abnormalities which may require rectification.

! Refuelling

There is a risk of fire and explosion when refuelling. The engine must be stopped and smoking is prohibited.

Do not overfill the tank due to a risk of expansion, and close the filler cap properly.

Use only fuel recommended in the workshop literature. Fuel of the wrong grade could cause the engine to malfunction or stop by preventing the injection pump and injectors from operating as they should.

This can cause damage to the engine and, possibly, injury.

! Hazardous gases

Only start the engine in a well ventilated area. The exhaust gases contain carbon monoxide and nitrogen oxides, which are toxic.

If it is run in an enclosed space, there should be an effective device to extract exhaust gases and crankcase gases.

! Starter lock

If the control panel is not fitted with a key operated switch, there should be a lock on the engine compartment to prevent unauthorised starting of the engine.

Alternatively, a lockable on/off master switch or battery master switch can be used.

! Starter spray

Never use starter spray or similar agents to help start the engine. This can cause an explosion in the intake manifold and possible injury.

! Running

The engine must not be run in environments where there is a risk of explosion as all of the electrical or mechanical components can generate sparks.

Approaching a running engine always poses a safety risk. Parts of the body, clothes or dropped tools can get caught in rotating parts such as the fan and cause injury.

For personal safety all rotating parts and hot surfaces must therefore be shielded as much as possible.

Safety precautions for handling materials

! Fuel and lubricating oil

All fuels and lubricants and many chemicals are flammable. Always follow the instructions on the relevant packaging.

All work on the fuel system must be done with the engine cold. Fuel leaks and spillage on hot surfaces can cause fire.

Store soaked rags and other flammable materials safely so as to avoid spontaneous combustion.

! Batteries

The batteries contain and emit oxyhydrogen gas, particularly during charging, and this gas is flammable and highly explosive. There must be no smoking, naked flames or sparks near the batteries or the battery compartment.

Incorrect connection of a battery cable or jump lead can cause a spark, which in turn can cause the battery to explode.

! Chemicals

Most chemicals such as glycol, corrosion inhibitors, preservative oils, degreasing agents, etc. are hazardous to health. Always follow the safety precautions on the relevant packaging.

Some chemicals, such as preservative oil, are also flammable.

Store chemicals and other materials which are hazardous to health in approved containers, marking them clearly and storing them where they are inaccessible to unauthorised persons. Always hand in leftover or used chemicals to an authorised waste disposal contractor.

Safety precautions for care and maintenance

! Stop the engine

Always stop the engine before carrying out maintenance and repair work unless stated otherwise.

Prevent unwanted starting by taking out the starter key where applicable and disconnecting the power using the master switch or battery master switch and locking them. Also put up a warning sign somewhere appropriate, indicating that work is in progress on the engine.

Working with a running engine always poses a safety risk. Parts of the body, clothes or dropped tools can get caught in rotating parts and cause injury.

! Hot surfaces and fluids

There is always a risk of sustaining burns when an engine is hot. Therefore, take care not to come into contact with manifolds, the turbocharger, oil sump, hot coolant and oil in pipes and hoses.

! Lifting the engine

The engine lifting eyes must be used when lifting the engine. Check first that your lifting tools are in good condition and of the correct size to lift the weight.

Extra equipment on the engine can alter the centre of gravity, which is why you may need additional lifting devices to balance the engine correctly and lift it safely.

Never work underneath a suspended engine!

! Batteries

The batteries contain a highly corrosive electrolyte (sulphuric acid). Take care to protect your eyes, skin and clothes when charging or handling batteries. Wear protective gloves and goggles.

If the acid splashes on your skin, wash it off with soap and copious amounts of water. If acid splashes in your eyes, flush them immediately with copious amounts of water and contact a doctor.

Dispose of used batteries through an authorised waste disposal contractor.

! Electrical system

The engine must be stopped and the power disconnected using the master switch or battery master switch before working on the electrical system.

External power supplies to extra equipment on the engine must also be disconnected.

! Electric welding

When carrying out welding work close to and on the engine, remove the electrical cables to the battery and the cables to the alternator. Also remove the multi-pin connector to the control unit.

Connect the weld clamp to the component to be welded and close to the welding point, never to the engine or in such a manner that the current can pass over to a mounting.

When you have finished welding, connect the cables to the alternator and control unit before connecting the batteries.

! Lubrication system

Hot oil can cause burns and skin irritation. Therefore, avoid skin contact with hot oil.

Make sure that there is no pressure in the lubricating system before starting work on it. Never start or run the engine with the oil filler cap removed, as this may cause oil to be thrown out.

Dispose of used oil through an authorised waste disposal contractor.

! Cooling system

Never open the coolant filler cap if the engine is hot. Hot coolant or steam may spray out and cause burns.

If you have to open or remove a cooling system component when the engine is hot, open the cap very carefully and slowly to relieve the system pressure before removing the cap. Wear gloves as the coolant is still very hot.

Dispose of used coolant through an authorised waste disposal contractor.

! Fuel system

Always wear gloves when looking for leaks or carrying out any other work on the fuel system. Also wear protective goggles when testing injectors.

Fuel escaping at high pressure can penetrate tissues and cause serious injury.

Never use non-genuine parts in the fuel and electrical systems as genuine parts are designed and manufactured to minimise the risk of fire and explosion.

! Before starting

Fit all removed shields before starting the engine again. Check that you have not left any tools or other objects on the engine.

Do not start the engine until the air filter is fitted. There is a risk of objects being sucked into the compressor impeller or of injury if you come into contact with it.

Type designations

The engine type designation indicates, in the form of a code, the engine type, its size and applications.

The type designation and engine serial number are shown on a type plate located on the block on the rear of the engine above the sea water pump. The engine serial number is also stamped on the front right-hand side of the cylinder block, in front of cylinder head 1. See illustration.

Engines which hold certification in respect of smoke and emissions are fitted with a plate which indicates the documents in accordance with which they are certified.

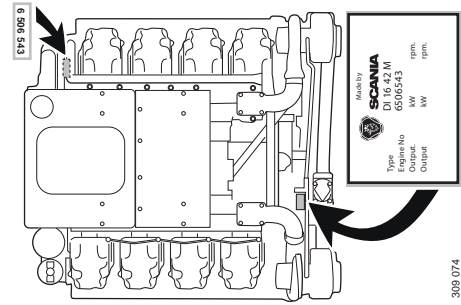

DI 16 42 M

Version

DI Supercharged diesel engine with liquid-cooled charge air cooler

Displacement in whole dm³

Performance and certificate

Indicates, together with the application code, the normal gross engine output.
The actual output setting of the engine is indicated on the engine card.

Application

M For marine use

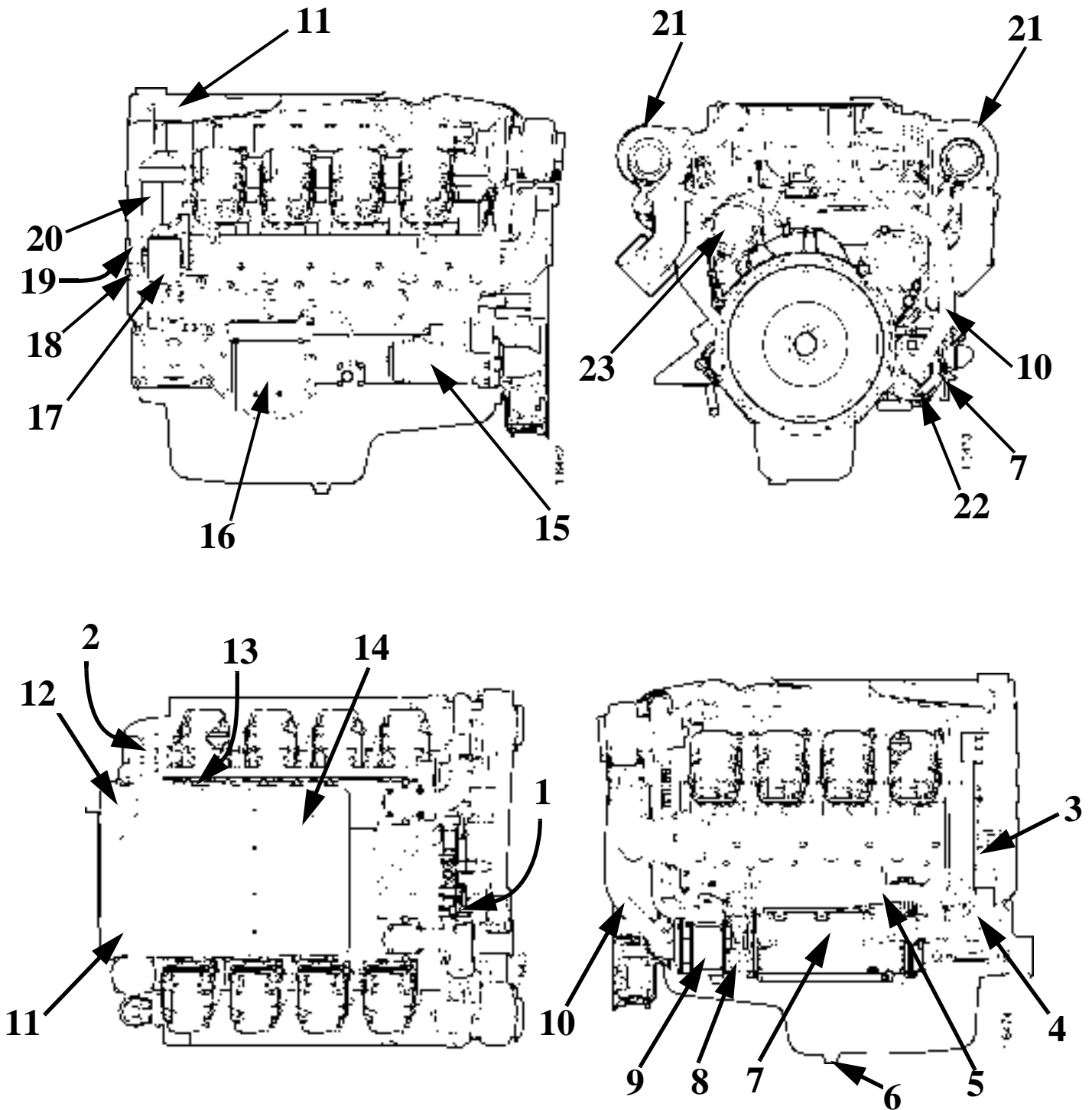

The illustrations show a normal version of a DI16 engine.
Your engine may have different equipment from the one illustrated

- | | | |
|--|--|------------------------------|
| 1. Type plate | 7. Heat exchanger (main circuit) | 15. Starter motor |
| 2. Engine serial number, stamped into the cylinder block | 8. Sea water outlet | 16. Control unit |
| 3. Thermostat housing with thermostat (double) | 9. Heat exchanger (charge air circuit) | 17. Fuel filter |
| 4. Outlet from engine | 10. Sea water intake | 18. Oil dipstick |
| 5. Outlet from heat exchanger | 11. Expansion tank | 19. Fuel pump with hand pump |
| 6. Drain, engine oil | 12. Filler, coolant | 20. Oil filter |
| | 13. Alternator | 21. Turbocharger |
| | 14. Catwalk | 22. Sacrificial anodes (2) |
| | | 23. Sea water pump |

EMS engine management system

This engine has an electronic management system, EMS (Engine Management System), with unit injectors (PDE) which provide each cylinder with the right amount of fuel at the right time in all operating situations.

The EMS system consists of a control unit (S6) and sensors for speed, charge air temperature and pressure, coolant temperature, oil pressure, accelerator pedal/throttle actuation which constantly emit signals to the control unit. With the aid of this input data and the set control program, the correct amount of fuel and the correct injection time are calculated for each unit injector (PDE) under the specific operating conditions.

The EMS system sensors can also be used to emit signals to the instruments in the instrument panel.

The control unit constantly monitors the sensors to make sure they are operational.

The control unit contains monitoring functions to protect the engine in the event of a fault which would otherwise damage it. In the event of a fault, e.g. alarm level for low oil pressure or high coolant temperature, the S6 control unit sends a CAN message to a coordinator.

The main task of the coordinator is to pass on data by means of CAN communication from the engine control unit to other control units and signals to gauges and lamps in the instrument panel. The coordinator also has monitoring functions.

When the EMS control unit or the coordinator detects a fault, the diagnostics lamp on the instrument panel(s) comes on, and it stays on as long as the fault is active. At the same time, a fault code is generated which can be read off via the coordinator on the diagnostics lamp in the form of a flash code when the diagnostics switch is activated. A flash code may consist of a number of different fault codes.

Diagnosis and troubleshooting using Scania EMS display is described in the Operator's Manual for Scania instrumentation.

If the torque reduction function is activated, the amount of fuel and the engine power are reduced to 70%, and if engine shutdown is activated, the engine is switched off at programmed alarm levels.

A separate PC-based diagnostics program is used to read off the contents of the flash codes. For an in-depth analysis of fault codes, contact an authorised Scania dealer.

Reading off the fault codes, and descriptions of these, are also covered in a separate document in the Workshop Manual, Engine Management System EMS-S6: Troubleshooting.

Only authorised personnel are allowed to carry out diagnostic procedures and program changes.

The positions of the sensors which emit signals to the control unit are shown in the illustrations on page 13.

See pages 14 and 16 for a description of how to read off flash codes.

See pages 15 and 17 for a list of flash codes for the control unit and coordinator.

Location of sensors for EMS with S6 on DI16

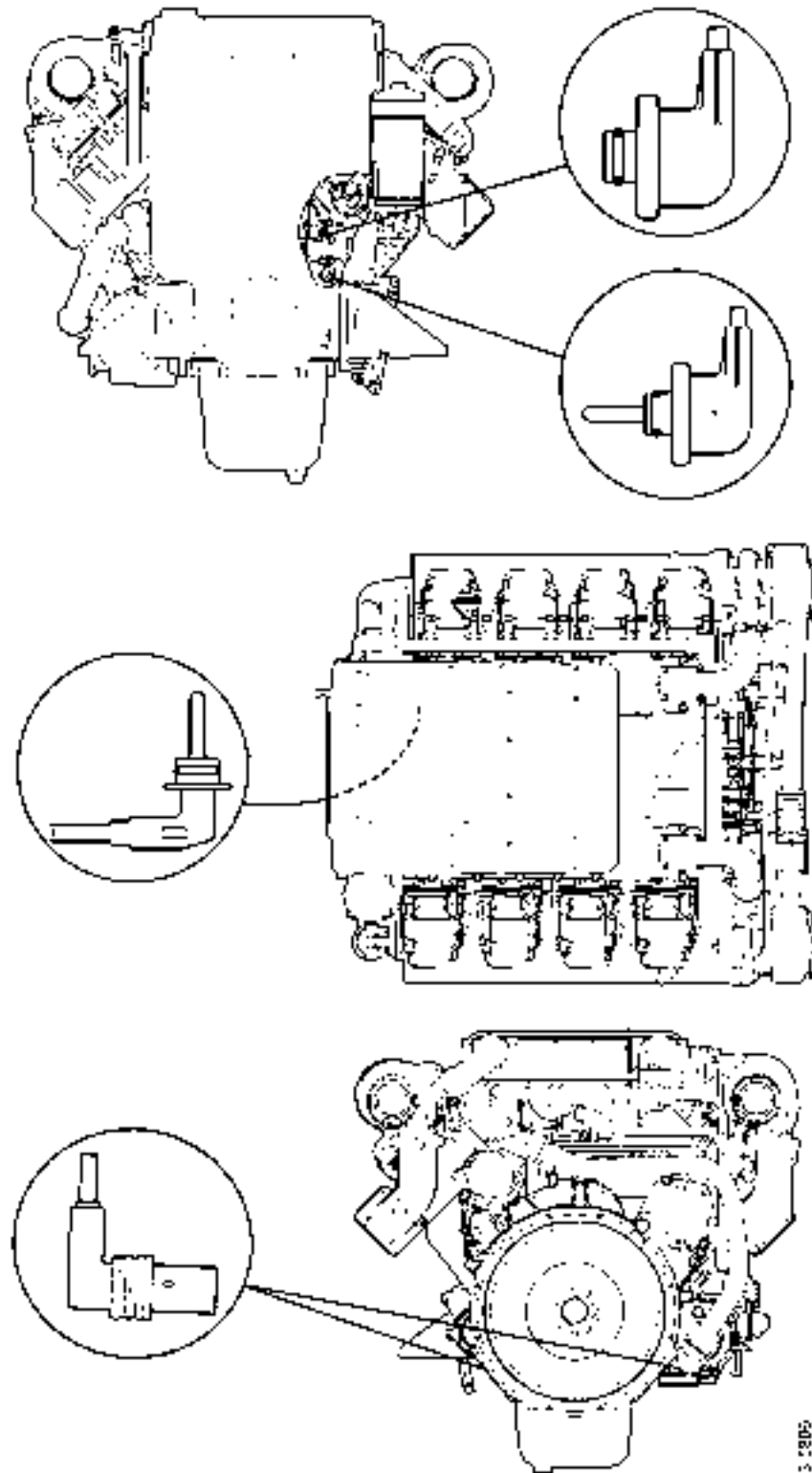

1. Oil pressure sensor
2. Coolant temperature sensor
3. Charge air temperature and pressure sensor
4. Engine speed sensor (2)

Troubleshooting using flash codes for the EMS control unit

- The diagnostics lamp on the instrument panel(s) always comes on for 2 seconds when the system is powered up.
- As soon as a fault is detected by the control unit, it is stored in the EEPROM fault code memory and the diagnostics lamp on the instrument panel(s) comes on.
- The diagnostic lamp will stay on for as long as a fault is active. Even if the lamp has gone off and the fault is no longer active, the code can generally be read off by following the instructions below.

Reading off control unit fault codes

1. Switch on the 15-supply.
2. Activate the diagnostics switch to the left to view the flash codes for the control unit (EMS).
3. A fault code will then flash on the diagnostic lamp. This flash code consists of long flashes (approximately 1 second long) and short flashes (0.3 seconds long). Long flashes are equivalent to units of 10, and short flashes are equivalent to units of 1.
Example: *long - short - short = fault code 12.*
4. Repeat this procedure until the first flash code is repeated. This means that the entire fault code memory has been flashed out. If the fault code memory is empty, only one long flash approx. 4 seconds long will be given.
5. See the flash code table on the next page for a description and to locate the fault.
6. In order to obtain further information about the fault code, the PC-based diagnostics tool or *Scania EMS display* must be used. Contact an authorised Scania workshop.
7. When a fault has been rectified the fault code can be cleared as described below.

Clearing fault codes

1. Switch off the 15-supply. If dual instrumentation has been fitted, the 15 voltage must be switched off on both panels.
2. Activate the diagnostics switch in the same direction as the flash codes indicate, i.e. to the right for the coordinator (COO) or to the left for EMS.
3. Switch on the 15 voltage and at the same time keep the diagnostics switch activated, to the right (COO) or to the left (EMS), for 3 seconds.
4. This will erase passive fault codes which can be read via flash codes for the relevant system. The rest of the fault codes will remain in the EEPROM and can only be deleted using the PC tool.

Overview of flash codes for the EMS control unit

Code	Description	Code	Description
0	No fault detected.	53	PDE in cylinder 3: The solenoid valve is not working properly.
11	Engine overspeed. One or both engine speed sensors are indicating engine speeds in excess of 3,000 rpm.	54	PDE in cylinder 4: The solenoid valve is not working properly.
12	Rotational speed sensor 1 faulty, or incorrect signal.	55	PDE in cylinder 5: The solenoid valve is not working properly.
13	Engine speed sensor 2 faulty, or incorrect signal.	56	PDE in cylinder 6: The solenoid valve is not working properly.
14	Coolant temperature sensor faulty, or incorrect signal.	57	PDE in cylinder 7: The solenoid valve is not working properly.
15	Charge air temperature sensor faulty, or incorrect signal.	58	PDE in cylinder 8: The solenoid valve is not working properly.
16	Charge air pressure sensor faulty, or incorrect signal.	59	Incorrect signal in extra analogue input.
17	Oil temperature sensor faulty, or incorrect signal.	61	Incorrect control unit shutdown.
18	Oil pressure sensor faulty, or incorrect signal.	66	Shutdown due to coolant level.
21	Coolant level sensor faulty.	68	Alternator charging incorrectly
23	Internal fault code in the coordinator.	69	Starter motor function interrupted or not activated.
24	Accelerator pedal/brake. If the accelerator and brake pedals have been operated simultaneously.	82	Engine speed above ref. engine speed at start
25	Accelerator pedal sensor/idling switch Accelerator pedal sensor/kickdown switch	83	Fault in memory circuit (EEPROM) in control unit.
27	Engine shutdown bypassed.	84	Data transfer to the control unit memory (EEPROM) has been interrupted.
28	Shutdown due to oil pressure.	85	Incorrect internal temperature in the control unit.
31	Torque limitation due to oil pressure	86	Internal fault in the control unit: Fault in hardware control.
32	Incorrect parameters for <i>limp home</i> function.	87	Fault in control unit RAM.
33	Battery voltage incorrect or no signal.	88	Internal control unit fault: Memory fault
37	Emergency stop switch activated in accordance with CAN message from coordinator.	89	Defective seal: Prohibited changes in software.
43	CAN communication circuit faulty in the control unit.	93	Engine speed sensors faulty or not connected.
47	Immobiliser function. Starter key code incorrect.	94	Shutdown due to high coolant temperature.
48	CAN message from the coordinator incorrect or missing.	96	Torque limitation due to high coolant temperature.
49	Incorrect CAN version in control unit or coordinator.	98	Incorrect voltage supply to one of the sensors.
51	PDE in cylinder 1: The solenoid valve is not working properly.	99	Internal hardware fault in the processor (TPU).
52	PDE in cylinder 2: The solenoid valve is not working properly.		

Troubleshooting using flash codes for the EMS coordinator

- The diagnostics lamp on the instrument panel(s) always comes on for 2 seconds when the system is powered up
- As soon as a fault is detected by the coordinator, it is stored in the EEPROM fault code memory and the diagnostics lamp on the instrument panel(s) comes on.
- Even if the lamp has gone off and the fault is no longer active, the code can generally be read off by following the instructions below.

Reading off coordinator fault codes

1. Switch on the 15-supply.
2. Activate the diagnostics switch to the right for 1 second to view the flash codes for the coordinator (COO).
3. A fault code will then flash on the diagnostic lamp. This flash code consists of long flashes (approximately 1 second long) and short flashes (0.3 seconds long). Long flashes are equivalent to units of 10, and short flashes are equivalent to units of 1.
Example: *long - short - short = fault code 12.*
4. Repeat this procedure until the first flash code is repeated. This means that the entire fault code memory has been flashed out. If the fault code memory is empty, only one long flash (approx. 4 seconds long) will be given.
5. See the flash code table on the next page for a description and to locate the fault.
6. In order to obtain further information about the fault code, the PC-based diagnostics tool or *Scania EMS display* must be used. Contact an authorised Scania workshop.
7. When a fault has been rectified the fault code can be cleared as described below.

Clearing fault codes

1. Switch off the 15-supply. If dual instrumentation has been fitted, the 15 voltage must be switched off on both panels.
2. Activate the diagnostics switch in the same direction as the flash codes indicate, i.e. to the right for the coordinator (COO) or to the left for EMS.
3. Switch on the 15 voltage and at the same time keep the diagnostics switch activated, to the right (COO) or to the left (EMS), for 3 seconds.
4. This will erase passive fault codes which can be read via flash codes for the relevant system. The rest of the fault codes will remain in the EEPROM and can only be deleted using the PC tool.

Overview of flash codes for the EMS coordinator

Flash code	Fault description
11 ¹⁾	Incorrect signal from the fine adjustment for the nominal engine speed signal.
11 ²⁾	Incorrect signals from the accelerator pedal sensor.
12 ¹⁾	Incorrect signal from the resistor module for governor setting.
12 ²⁾	Incorrect signal from the resistor module for idle and fixed speed setting.
13	No communication (EMS) with the engine.
14	Short circuit in the tachometer signal cable.
15	Faulty atmospheric pressure sensor.
17	Short circuit in the coolant temperature gauge signal cable.
18	Short circuit in the oil pressure gauge signal cable.
19	Short circuit in the oil pressure lamp signal cable.
21	Different versions of the communications protocol between the coordinator and EMS.
22	Faulty start switch or short circuit.
23	The supply voltage is too high.
24	The supply voltage is too low.
25	Check value from <i>End of Line</i> (EOL) is incorrect.
26	Road speed sensor signal missing or incorrect.
27	The signals from the RCB (Remote Control Box) switches are implausible.
28	Incorrect signals from the droop setting switches.
29	Faulty remote start switch or short circuit.
31	No communication from the slave coordinator or the master coordinator.
32	Short circuit in the signal cable to the coolant temperature warning lamp.
33	Short circuit in the signal cable to the charge warning lamp.
34	Incorrect signal from the <i>Fixed speed</i> switches.
35	Fault in CAN communication.

1) Single-speed engine

2) All-speed engine

Starting and running

First start

When the engine is started for the first time, the inspection points listed under "First start" in the inspection schedule should be followed, see page 25.

Since the points are important for satisfactory operation of the engine right from the outset, they are also listed below.

1. Checking the oil level, see page 27.
8. Checking the coolant, see page 33.

The coolant must contain corrosion inhibitor to protect the cooling system from corrosion.

If there is a danger of freezing:

- Only antifreeze glycol should be used in the coolant as protection against corrosion. Scania recommends only nitrite-free antifreeze glycols with the following supplier designations:

BASF G48 or BASF D542

- The concentration of glycol should be 30-60% by volume depending on the ambient temperature. 30% glycol by volume provides anti-freeze protection down to -16°C. See page 33.
- Never top up with water alone or glycol alone! Fluid losses must always be replaced with pre-mixed coolant having the same glycol concentration as that in the engine. If the glycol content drops, both antifreeze protection and protection against corrosion are impaired.

Note: A glycol concentration below 30% by volume will not provide sufficient protection against corrosion. Glycol concentrations higher than 60% do not improve antifreeze protection and have an adverse effect on engine cooling capacity.

If there is no danger of freezing:

- Only Scania Corrosion Inhibitor should be used in the coolant as protection against corrosion. The correct concentration of corrosion inhibitor is 8-12% by volume, and this must never drop below 8% by volume. The inhibitor in Scania Corrosion Inhibitor is free of nitrites.
- First filling: Fill up the system with water +10% by volume Scania Corrosion Inhibitor. Use drinking water with a pH of 6-9.
- Never top up with water alone or corrosion inhibitor alone! Fluid losses must always be replaced with pre-mixed coolant: water + 10% Scania Corrosion Inhibitor by volume.

Coolant filter (not standard equipment)

Only coolant filters without inhibitor may be used. The use of coolant filters increases the life of the coolant and reduces the risk of deposit corrosion.

Coolant composition:
If there is a danger of freezing:
 min 30% glycol by volume
 max 60% glycol by volume
If there is no danger of freezing:
 8-12% by volume
Scania Corrosion Inhibitor
 (no glycol)



WARNING

Ethylene glycol and corrosion inhibitor can be fatal if ingested.
Avoid contact with the skin.



Important

The recommended glycols must not be mixed with glycol containing nitrite-based corrosion inhibitor.



WARNING

Overdosing with *Scania Corrosion Inhibitor* and mixing with glycol can cause sludge to be formed.



WARNING

If a coolant filter has been fitted it must not contain inhibitor.

- 12. Checking the fuel level, see page 42.
- 14. Checking the electrolyte level in batteries, see page 44.
- 15. Checking the state of charge in batteries, see page 44.
- 18. Checking the drive belt tension, see page 46.

Checks before running

Before running, "Daily maintenance" as described in the inspection schedule should be carried out, see page 25.



WARNING

Block the starting device when working on the engine. If the engine starts unexpectedly, there is a SERIOUS RISK OF INJURY.

Starting the engine

If the fuel tank has been run dry or if the engine has not been used for a long time, bleed the fuel system.

Out of consideration for our common environment, your Scania engine has been designed to use less fuel when starting. Using unnecessarily large amounts of fuel when starting the engine always results in emissions of unburnt fuel.

- Open the inlet valve for the sea water system (if fitted).
- Open the fuel cock if fitted.
- Disengage the engine.
- Engines with battery master switch: Switch on the power by means of the battery master switch.
- Start the engine with the key in the control panel (SCP) or the start button (only from RCB).
- **S6**: The diagnostics lamp should go out after approximately 2 seconds when starting.



WARNING

Only start the engine in a well ventilated area. If it is run in an enclosed space, there should be an effective device to draw off exhaust gases and crankcase gases.



WARNING

Never use starter spray or similar agents to help start the engine. An explosion may occur in the intake manifold with a risk of personal injury.

Starting at low temperatures

Local environmental requirements must be complied with. Starting aids, engine heaters should be used to avoid starting problems and white smoke.

To limit white smoke, the engine should be run at low speed and under moderate load. A moderate load on a cold engine gives better combustion and faster heating than warming up with no load.

Avoid running it longer than necessary at idling speed.

At temperatures below 0°C:

Note: Only use starting aids recommended by Scania.

- The starter motor must only be cranked for 30 seconds at a time. After that it must rest for 30 seconds before the next attempt to start it. Max. 5 start attempts are permitted. After that the starter motor must rest for 15 minutes before the procedure can be repeated.

Note: If the engine is equipped with an INTERLOCK switch, this switch should be depressed and held down until the oil pressure has reached a sufficiently high level.



WARNING

The starter motor may only be cranked for a maximum of 30 seconds. There is a risk of overheating. Let the starter motor rest for 30 seconds between each attempt to start the engine.

Running

Check instruments and warning lamps at regular intervals.

Engine speed

The Scania tachometer is divided into different coloured sectors as follows.

0-500 rpm	red area:	prohibited engine speed, passed through when stopping and starting.
500-700 rpm	yellow area:	slow idle. Engine idling is controlled by the EMS/S6 control system. Fixed raised idling speed with a cold engine. See page 20.
700-2,200 rpm	green area:	normal operating speed The engine operating speed range is controlled by the EMS/S6 control system.
2,200-2,600 rpm	yellow/green striped area:	unsuitable operating speed. May occur when switching off.
2,600-3,000 rpm	red area:	prohibited engine speed.

Limp home mode

If there is a fault on the normal accelerator pedal or if CAN communication is interrupted, the following limp-home option is available:

CAN fault or accelerator pedal fault (both signal and idling switch):

- The accelerator pedal value is 0 % and the engine is running at normal idling speed.
- The accelerator pedal value is 0% and the engine is running at fixed raised idling speed (750 rpm) if this function is activated.

Accelerator pedal malfunction but the idling switch is working:

- The accelerator pedal value can be increased slowly between 0% and 50% by using the idling switch.

CAN fault:

- The engine is switched off if the shutdown function is activated.

Coolant temperature

Normal coolant temperature when the engine is running should be 70-90°C.

The EMS/S6 control system has the following alarm levels for elevated coolant temperatures:

The basic values are 95°C for the lower level and 105°C for the higher level.

- If the temperature is over 95°C for a certain period (1 second), S6 will send a CAN message which switches on the warning lamp and diagnostics lamp via the coordinator.
- If the temperature exceeds 95°C and torque reduction is activated, the warning lamp and the diagnostics lamp will come on and the amount of fuel will be reduced to 70%. A fault code is generated in the control unit.
- At temperatures exceeding 105°C and with engine shutdown activated, the warning lamp and diagnostics lamp come on and the engine is switched off. If override is activated, only torque reduction works. A fault code is generated in the control unit.

After an alarm, approved values should be registered for more than 2 seconds to reset the alarm.

Excessively high coolant temperature can damage the engine.

If run for extended periods under an extremely light load, the engine may have difficulty in maintaining normal operating temperature. However, the temperature will rise to a normal level again when the load on the engine is increased.

Oil pressure

Max. oil pressure:

warm engine running at a speed above 800 rpm 6 bar

Normal oil pressure:

warm engine at operating speed 3-6 bar

Min. oil pressure:

warm engine running at 1,000 rpm 2.3 bar

High lubricating oil pressure (above 6 bar) is normal when starting a cold engine.

The control system has the following alarm levels:

- at a speed of less than 1,000 rpm and an oil pressure of less than 1.0 bar
- at a speed of more than 1,000 rpm and an oil pressure of less than 2.3 bar for longer than 5 seconds.

The following functions are available if there is an alarm:

- Alarm which only switches on the warning lamp and diagnostics lamp.
- Alarm which switches on the warning lamp and diagnostics lamp as well as torque reduction if this function is activated (70% of fuel quantity).
A fault code is generated in the control unit.
- Alarm which switches on the warning lamp and diagnostics lamp. The engine is switched off if engine shutdown is activated. If the override function is activated, only torque reduction takes place when this function is activated.
A fault code is generated in the control unit.

After an alarm, approved values should be registered for more than 1 second to reset the alarm.

Charging indicator lamp

If the lamp comes on during operation:

- Check and adjust the alternator drive belt as described under the inspection point; see page 46.
- If the charging indicator lamp is still on, this could be due to an alternator fault or a fault in the electrical system.

Stopping the engine

1. Run the engine without a load for a few minutes if it has been run continuously with a heavy load.
2. Stop the engine with the stop button or the starter key (depending on version). Keep the stop button depressed until the engine has stopped completely.
3. Before disconnecting the power, check that the control system diagnostics lamp is not on. See page 14 for troubleshooting.
4. Set the control switch to the "0" position.
5. Engines with battery master switch: Switch off the power using the battery master switch.

Note: If the engine is stopped improperly 10 times, torque reduction will be activated (70% fuel volume). To reset the engine, shut it down once in the specified manner.

Checks after running

- Check that the power is cut from the battery master switch and that the control switch is in the 0 position.
- Fill the fuel tank. Make sure that the filler cap and the area round the filler opening are clean to avoid contamination of the fuel.
- If there is a risk of freezing, the cooling system must contain enough glycol. See pages 18 and 33.
- Switch off inlet valve for the sea water system (if fitted).
- If there is danger of freezing the sea water system must be emptied.
- At temperatures below 0°C: prepare for the next start by connecting the engine heater (if fitted).



Important

There is danger of turbocharger damage and post boiling if the engine is stopped without cooling.



Important

The power must not be switched off before the engine has stopped.



WARNING

Block the starting device when working on the engine. If the engine starts unexpectedly, there is a SERIOUS RISK OF INJURY.



WARNING

Coolant should be topped up when the engine is stopped after the first start.

Maintenance

The maintenance programme covers 21 points, divided into the following main groups:

- Lubrication system page 26
- Cooling system page 31
- Air cleaner page 40
- Fuel system page 42
- Electrical system, batteries, etc. page 44
- Miscellaneous page 46

The inspection points are divided into intervals as follows:

Daily maintenance

Maintenance before the first start

Maintenance after the first 400 hours of operation

Periodic maintenance every 200 hours of operation. Carried out at 200, 400, 600, 800 etc. hours.

Periodic maintenance every 400 hours of operation. Carried out at 400, 800, 1,200, 1,600 etc. hours.

Periodic maintenance every 1,200 hours of operation. Carried out at 1,200, 2,400, 3,600 etc. hours.

Periodic maintenance every 2,400 hours of operation. Carried out at 2,400, 4,800 etc. hours.

Periodic maintenance every 4,800 hours of operation. Carried out at 4,800, 9,600 etc. hours.

Annual maintenance.

Maintenance every 5 years.



Block the starting device when working on the engine. If the engine starts unexpectedly, there is a SERIOUS RISK OF INJURY.

Engines with few hours of operation

Emergency generator sets etc., that are not used regularly should be test run and checked in accordance with the generator set manufacturer's instructions.

Run the engine until it reaches operating temperature and then carry out the inspection points below:

1. Checking oil level.
5. Checking coolant level.
10. Checking vacuum indicator.
12. Checking fuel level.
14. Checking electrolyte level in batteries.
15. Checking state of charge in batteries.
16. Cleaning batteries.
19. Check for leaks, rectify as necessary.



Important

**For engines with few operating hours that do not receive periodic maintenance according to the inspection schedule on page 25, maintenance should be carried out in accordance with the schedule:
"Annually"
"Every 5 years"**

Inspection schedule

	<i>First time at</i>		<i>Interval</i>					<i>At least</i>		
	<i>Daily</i>	<i>First start</i>	<i>400 h</i>	<i>200 h</i>	<i>400 h</i>	<i>1,200 h</i>	<i>2,400 h</i>	<i>4,800 h</i>	<i>Annually</i>	<i>Every 5 years</i>
Lubrication system, page 26	•	•								
1. Checking the oil level	•	•								
2. Oil change					•1				•	
3. Cleaning the centrifugal oil cleaner					•1				•	
4. Renewing the oil filter and closed crankcase ventilation filter					•1				•	
Cooling system, page 31	•									
5. Checking coolant level	•									
6. Checking sacrificial anodes 4)					•5				•	
7. Checking the sea water pump impeller 4)					•5				•	
8. Checking the coolant		•					•6		•6	
9. Cleaning the cooling system								•1		•
Air cleaner, page 40	•									
10. Checking the read-out from the vacuum indicator	•									
11. Cleaning or renewing the filter element						•3				•
Fuel system, page 42	•	•								
12. Checking fuel level	•	•								
13. Renewing the main filter and water separating filter						•1				•
Electrical system, page 44		•		•2					•	
14. Checking the electrolyte level in batteries		•		•2					•	
15. Checking the state of charge in batteries		•			•2				•	
16. Cleaning batteries					•2				•	
17. Checking the coolant level monitor					•				•	
Miscellaneous, page 46		•				•			•	
18. Checking the drive belt		•				•			•	
19. Check for leaks, rectify as necessary	•									
20. Checking and adjusting the valve clearance			•				•			
21. Checking and adjusting PDE injector rocker arms			•				•			

1. More often if required.
2. For engines with few operating hours, see page 24.
3. Earlier if the vacuum indicator shows red.
4. Only applies to marine engines with sea water pump and heat exchanger.
5. Guideline value. Varies depending on the composition of the sea water.
6. If inhibitor has not been topped up for 5 years, the coolant should be changed.

Lubrication system

Oil grade

The engine oil must at least meet the requirements for one of the following oil classifications:

-ACEA E3, E4 or E5

- The Total Base Number (TBN) should be at least 12-13 (ASTM 2896).
- Check with your oil supplier that the oil meets these requirements.
- Specified oil change intervals apply provided that the sulphur content of the fuel does not exceed 0.3% by weight. If the sulphur content is greater than 0.3% but no more than 1.0%, the oil change interval must be halved (200 hours).
- Viscosities are shown in the figure below.
- For operation at extremely low outdoor temperatures: Consult your nearest Scania distributor on how to avoid starting difficulties.

!
Important

Additives must not be used.
The oil should be suitable for all temperature variations until the next oil change.

Oil analysis

Some oil companies can offer analysis of the engine oil. Such analysis measures the oil's TBN (Total Base Number), TAN (Total Acid Number), fuel dilution, water content, viscosity and the quantity of particles and soot in the oil.

The result of a series of analyses is used as the basis for establishing a suitable oil change interval.

If the conditions change, a new oil analysis programme must be carried out to establish the new change interval.

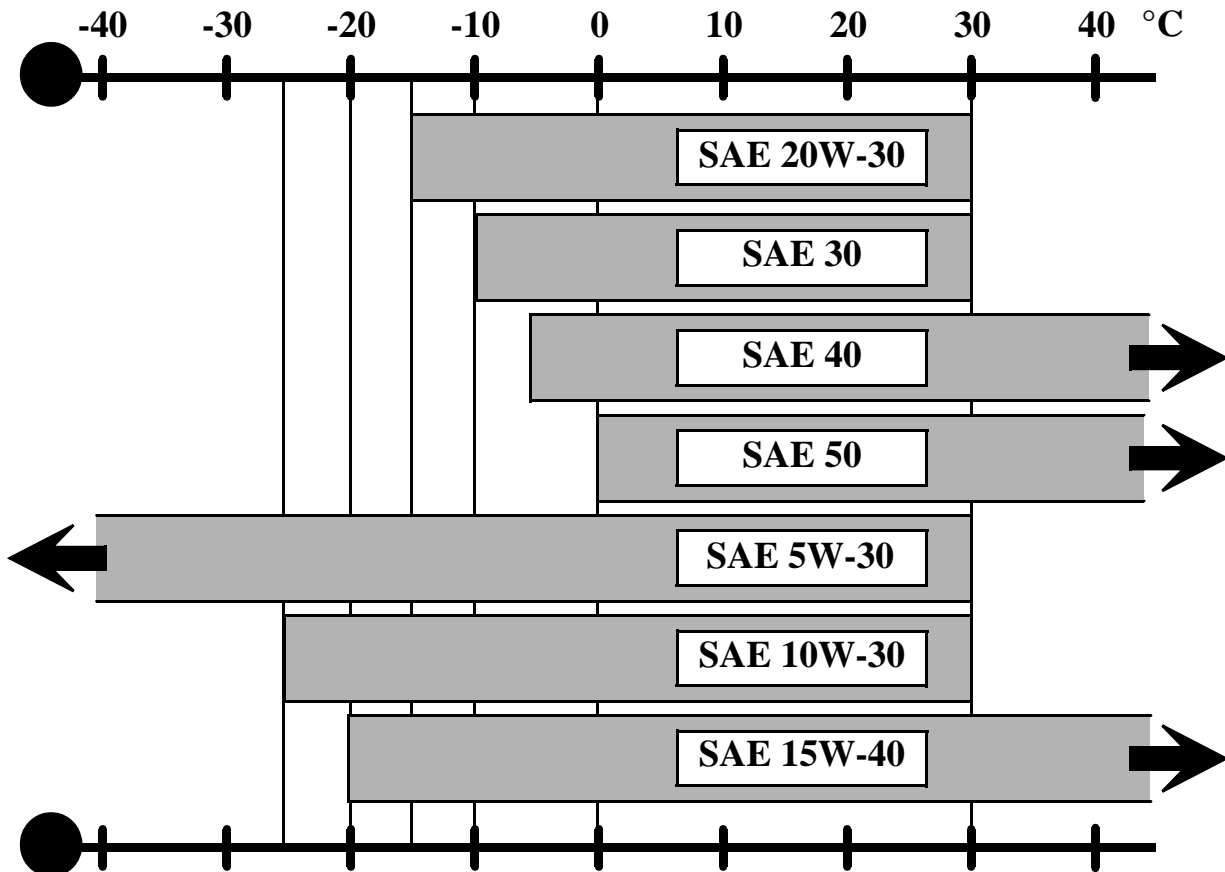

1. Daily:

Checking the oil level

Note: Before checking the oil level: leave the engine switched off for at least 1 minute.

- The correct level is between the marks on the oil dipstick. Top up when the oil level is at the lower mark on the dipstick.
- Refer to page 26 for correct oil grade.

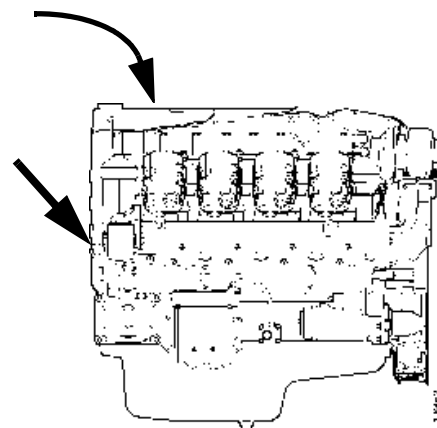

Checking the oil level during operation

On some engines the oil level can be checked during operation.

- Remove the oil filler cap to release the pressure in the crankcase.
- Check the level on the dipstick. Correct oil level: 10 mm below the Max. mark.

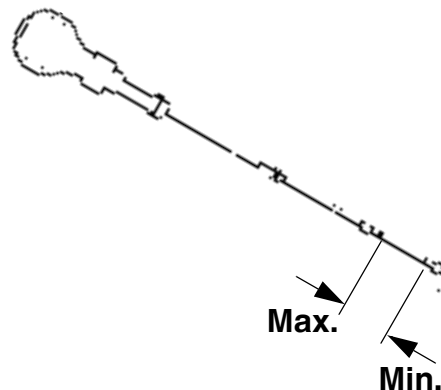

2. Every 400 hours:

Oil change

Note: If the engine is used for especially demanding operations, particularly in a dusty environment or if the deposits in the centrifugal oil cleaner are thicker than 20 mm: change the oil more frequently.

- Unscrew the oil plug and drain the oil when the engine is hot.
- In certain engines the oil is pumped out by means of a bilge pump.
- Clean the magnet on the oil plug.
- Refit the oil plug.
- Top up with oil.
- Check the level on the oil dipstick.



Max. 40 dm³
Min. 35 dm³

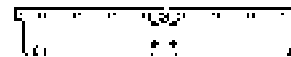

Max. 33 dm³
Min. 25 dm³

1 dm³ = 1 litre



WARNING

The oil may be hot.
Wear protective gloves and goggles.



Help protect our environment!

Use a container to avoid spills when changing the oil. Dispose of used oil through an authorised waste disposal contractor.

Maximum angles of inclination during operation

Maximum permissible angles during operation vary, depending on the type of oil sump, see illustration.

Note: The specified angles may only occur periodically.

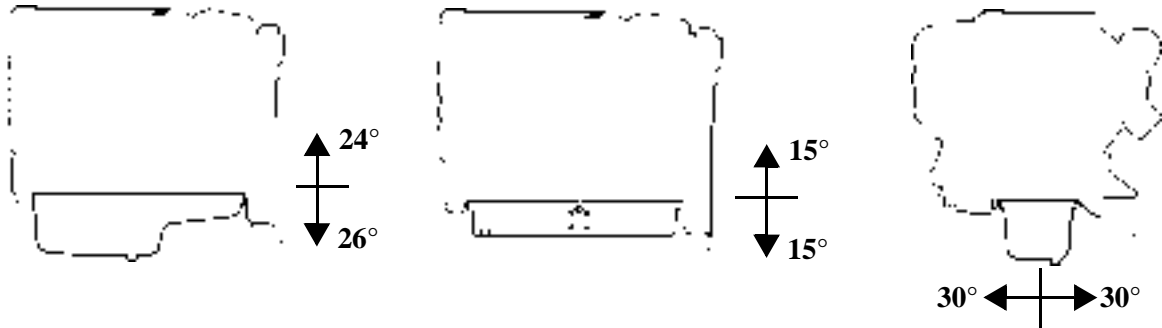

3. Every 400 hours: Cleaning the centrifugal oil cleaner (At the same time as an oil change)

- Clean the cover. Unscrew the nut and remove the cover.



WARNING

Open the cover carefully. The oil may be hot.

- Lift out the rotor and loosen the nut on the rotor cover 3 turns.

- If the nut is jammed:
Clamp the nut, **but never the rotor**, in a vice and turn the rotor 3 turns by hand or with a screwdriver.

- Tap the nut lightly with your hand or a plastic hammer, to detach the rotor cover from the bottom plate.



- Unscrew the nut and remove the rotor cover.
- Remove the strainer located on the rotor. If the strainer is stuck, you can prise its bottom edge carefully until it comes loose from the bottom plate.
- Scrape off the deposits from the inside of the rotor cover. If there are no deposits, this indicates that the cleaner is not working properly.
- If the deposits are thicker than 20 mm: clean more often.



- Wash all parts in diesel.
- Make sure the nozzles on the rotor are not blocked or damaged.
- Check that the bearings are not damaged.
- Fit the O-ring in the rotor cover. The O-ring must not be damaged. Renew if necessary.



- Assemble the rotor.

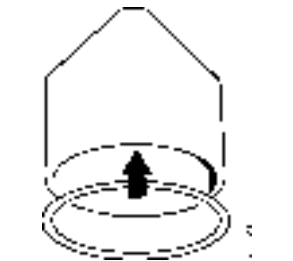

- Tighten the rotor nut firmly by hand.
- Check that the shaft is not loose. If it is loose, use thread-locking fluid 561 200 and torque tighten to 34 Nm.

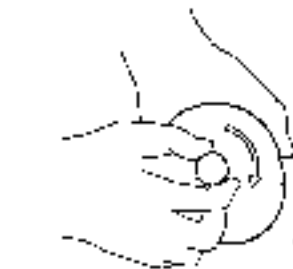

- Refit the rotor.
- Check that it rotates easily by rotating it manually.



- Check that the O-ring in the cover is not damaged. Renew hardened or damaged O-rings.
- Screw on the cover and tighten the lock nut to 15 Nm.

Tighten the nut carefully so as not to damage the rotor shaft, nut or cover.

15 Nm



Operational testing

The rotor rotates very fast and should continue to rotate when the engine has stopped.

- Stop the engine when it is warm.
- Listen for a whirring sound from the rotor or feel whether the oil cleaner housing is vibrating.

The rotor normally continues spinning for 30-60 seconds after the engine has stopped.

If not: dismantle and check.

4. Every 400 hours: Renewing the oil filter

(in connection with oil change)

- Unscrew the filter cover with a closed tool with hexagon driver, e.g. socket 587 637, so as not to damage the filter cover.
- Lift out the filter housing cover with filter element. The filter housing will drain automatically once the filter has been removed.
- Undo the old filter from the cover by carefully bending it to one side.
- Lubricate a new O-ring with engine oil and place it in the cover.
- Press a new filter element into the snap fastener in the cover.
- Make sure the oil filter drain has emptied the oil from the filter housing.
- Screw the cover into place with a closed tool with hexagon driver, e.g. socket 587 637. Tightening torque 25 Nm.
- Start the engine and check for leaks.

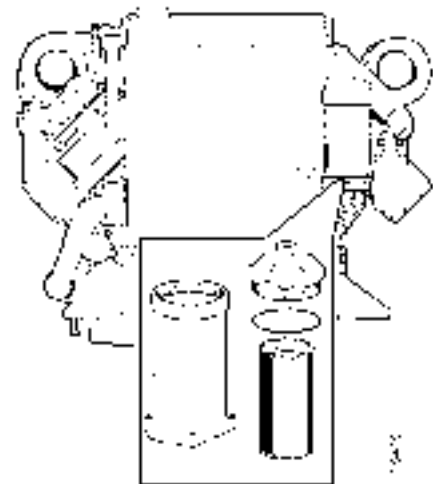

Help protect our environment!

Use a container to avoid spills when renewing the filter. Dispose of used filters through an authorised waste disposal contractor.

Important! *If the deposits in the centrifugal oil cleaner are more than 20 mm thick, the oil filter must be renewed more often. The same is true for cleaning the centrifugal filter and changing the oil.*

Renewing the closed crankcase ventilation filter

In the case of engines with closed crankcase ventilation, the filter element must be renewed at the same time as the main oil filter as described below:

- Remove the drainage line at the filter base.
- Release clamps (1) holding the container to the filter head.
- Remove the container (2). There may be oil in the bottom.
- Remove and renew the filter element.
- Replace the O-ring at the base of the head, and check that there is an O-ring on top of the new filter element.
- Fit the new filter and press it into the centre of the filter head.
- Refit the container and lock firmly.
- If the indicator (3) on top of the filter showed red, remove the plastic cover and press the indicator button.
- Refit the drainage line.

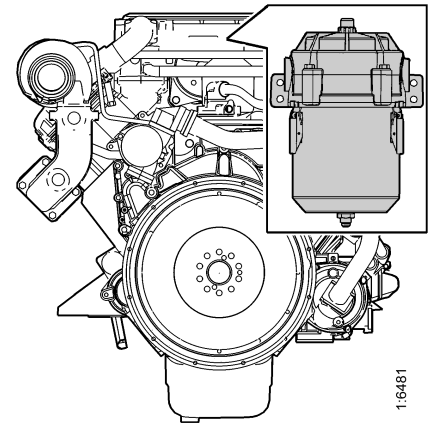

16481

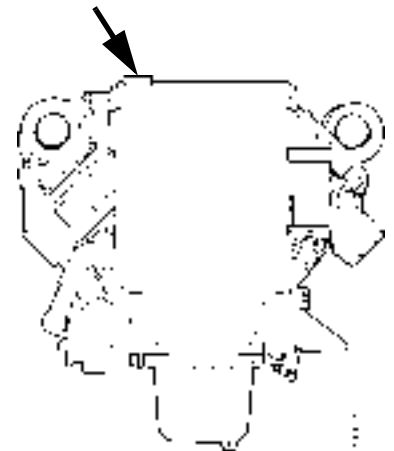
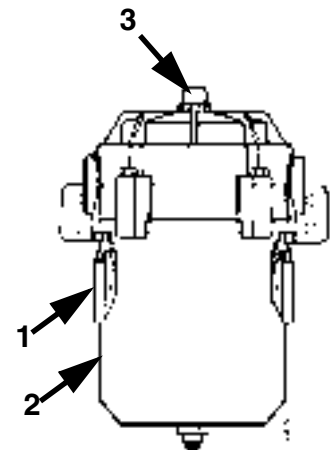

Cooling system

5. Daily:

Checking the coolant level

- Open the expansion tank filler cap and check the coolant level.
- *Correct level:*
 - Cold engine: The coolant level must be approximately 50 mm below the full line.
 - Hot engine: The coolant level must be approximately 25 mm below the full line.
- Other types of expansion tank according to the instructions of the fitter.
- Top up the coolant as necessary, see point 8.

Note: When filling large amounts of coolant:
Never pour cold coolant into a hot engine.
This could crack the cylinder block and cylinder head.



WARNING

Open the cover carefully.
Water and steam may spray out.



Important

Always top up with pre-mixed coolant.

6. Every 400 hours: Checking the sacrificial anodes (Only engines with heat exchanger)

- Empty the sea water circuit and check the sacrificial anodes. There are 2 of these, positioned as shown.
- Scrape off all loose material on the sacrificial anode.
- Renew if less than half of the sacrificial anode is left.
A new sacrificial anode is 63 mm long with a diameter of 17 mm.

Note: If the sacrificial anodes are very corroded they need to be checked more often, for example every 200 hours.

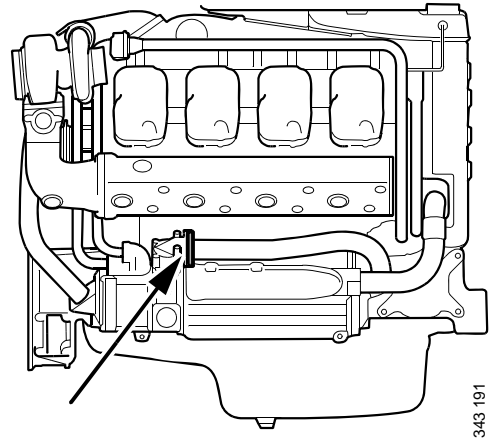

7. Every 400 hours: Checking the sea water pump impeller (Only engines with heat exchanger)

- Close the bottom valve if the sea water pump is below water level.
- Drain the sea water circuit.
- Take off the sea water pump cap.
- Check that the vanes of the impeller are not worn or damaged.

Note: If the impeller must be renewed frequently, the cleaning of the sea water needs to be improved.

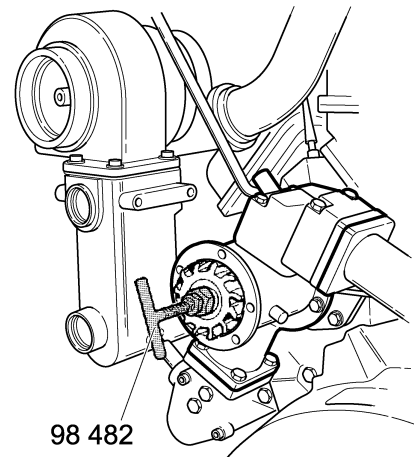

Renewing the impeller

- Pull out the impeller with puller 98 482 (Scania special tools).
- Fit a new impeller and cap. Check that the cap seal is not hard or damaged.

Note: There should be a spare impeller on board.

- The impeller can be deformed during extended periods of inactivity. Renew the impeller before starting or remove the impeller before longer periods of stoppage. Also see "Preparations for storage".

8. Every 2,400 hours: Checking the coolant

Coolant should be checked as follows:

- a) Check the appearance of the coolant.
- b) Coolant with glycol only: Check the glycol content.
- c) Coolant containing only Scania Corrosion Inhibitor: Check the corrosion inhibitor content.

The composition of the coolant is described in more detail under "Starting and running".

a) Checking the appearance of the coolant

- Pour a small amount of coolant in a container, and check that the coolant is pure and clear.
- If the coolant is contaminated or cloudy: consider changing the coolant
- Water for the coolant must be clean and free from contamination.
- Use drinking water with a pH of 6-9.

b) Checking the glycol content

If there is a danger of freezing, use only glycol as protection against corrosion in the coolant.

- Cooling systems with glycol should contain at least 30% glycol by volume to provide acceptable protection against corrosion.
- 30% glycol by volume provides antifreeze protection down to -16°C. If additional antifreeze protection is required, see the table on the next page to help you calculate how much glycol you need.

Scania recommends only nitrite-free antifreeze glycols with the following supplier designations:

BASF G48 or BASF D542

- Always add glycol if the glycol content drops below 30% by volume. A glycol content above 60% by volume will not provide greater protection against freezing.
- The table shows the temperature at which ice starts to form. The engine will freeze and break at appreciably lower temperatures, see diagram.
- Ice forming in the coolant often causes malfunctioning without any risk of damage. The engine should not be subjected to heavy loads when ice starts to form.

Note: The coolant should be changed when the cooling system is cleaned: every 4,800 hours or at least every 5 years.

Important! *If a coolant filter is used in the cooling system it must not contain an inhibitor.*

Coolant composition:

If there is a danger of freezing:
min 30% glycol by volume
max 60% glycol by volume

If there is no danger of freezing:
8-12% by volume
Scania Corrosion Inhibitor



WARNING

Ethylene glycol can be fatal if ingested.
Avoid skin contact with glycol.

The coolant should be pre-mixed when it is poured into the cooling system.
Never top up with only water or only glycol.



Important

The recommended glycols must not be mixed with glycol containing nitrite-based corrosion inhibitor.
Risk of a build-up of sludge and reduced cooling capacity.

% by volume of antifreeze glycol

Characteristics of glycol at low temperatures:

- Example with 30% glycol by volume
- Ice slush starts to form at -16°C.
- There is a risk of malfunctions at -30°C
- No risk of damage by freezing with a minimum content of 30% glycol by volume

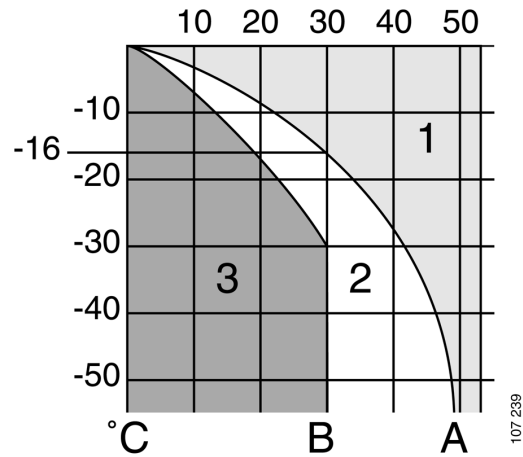

Curve A: Ice formation starts (ice slush)

Curve B: Temperature at which there is a risk of damage by freezing

1. Safe area
2. Malfunctions may occur (ice slush)
3. Risk of damage by freezing

A

% by volume of glycol	15	20	25	30	35	40	45	50	Cooling system capacity, dm ³
Ice slush starts to form at °C	-6	-9	-12	-16	-21	-24	-30	-37	
Ethylene glycol dm ³ (litre)	5	6	8	9	11	12	14	15	30
	6	8	10	12	14	16	18	20	40
	8	10	13	15	18	20	23	25	50
	9	12	15	18	21	24	27	30	60
	11	14	18	21	25	28	32	35	70
	12	16	20	24	28	32	36	40	80
	14	18	23	27	32	36	41	45	90
	15	20	25	30	35	40	45	50	100
	17	22	28	33	39	44	50	55	110
	18	24	30	36	42	48	54	60	120
	20	26	33	39	46	52	59	65	130
	21	28	35	42	49	56	63	70	140
	23	30	38	45	53	60	68	75	150
	24	32	40	48	56	64	72	80	160
	26	34	43	51	60	68	77	85	170
	27	36	45	54	63	72	81	90	180
	29	38	48	57	67	76	86	95	190
30	40	50	60	70	80	90	100	200	

A= Area to be avoided. Only for calculating glycol mix.

Coolant freezing point, when ice starts to form, for different glycol mixes

c)

Checking the corrosion inhibitor

There must always be sufficient corrosion inhibitor in the coolant to protect the cooling system against corrosion.

If there is no danger of freezing, only Scania Corrosion Inhibitor should be used in the coolant.

The inhibitor in Scania Corrosion Inhibitor is free of nitrites.

The correct proportion of corrosion inhibitor is 8-12% by volume.

- Topping up with 1.0% Scania Corrosion Inhibitor by volume should be done after every 2,400 hours of operation.
- Never top up with water alone or corrosion inhibitor alone!
Fluid losses must always be replaced with pre-mixed coolant:
water + 10% Scania Corrosion Inhibitor by volume.

Note: The coolant should be changed when the cooling system is cleaned every 4,800 hours or at least every 5 years.



WARNING

**Corrosion inhibitor can be fatal if ingested.
Avoid contact with the skin.**



Important

Mixing with glycol or the use of too much corrosion inhibitor can lead to a build-up of sludge and reduced cooling capacity.



Important

If a coolant filter has been fitted it must not contain inhibitor.

Changing the coolant

1. Remove the filler cap from the expansion tank.
2. The coolant is drained at 3 points:
 - 2 drain taps on the lower right-hand side of the block, see illustration
 - Drain tap on the lower left-hand side of the block, see illustration.
And at the lowest point of the cooling system, remove 2 plugs under the heat exchanger.
3. Close the drain taps.
4. Top up with coolant through the expansion tank's filler hole.
Mix coolant as described on page 33.

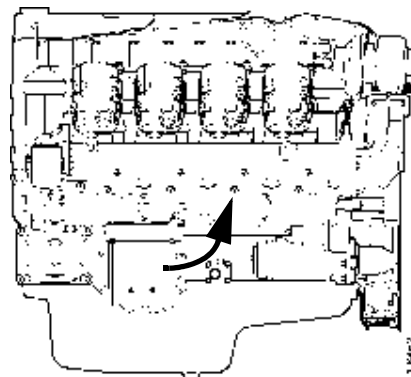
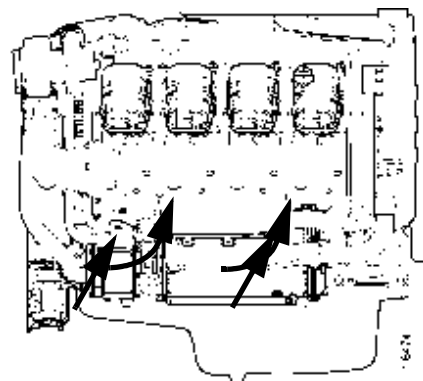

Help protect our environment!

**Use a container to avoid spills when changing the coolant.
Dispose of used coolant through an authorised waste disposal contractor.**

9. Every 4,800 hours: Cleaning the cooling system

Note: If necessary, the cooling system should be cleaned more often.

External cleaning

Heat exchanger

1. Drain the coolant from the engine and the heat exchanger, see "Changing the coolant".
2. Empty the sea water circuit and loosen the heat-exchanger sea water inlet and outlet connections. Remove the radiator, where fitted, with pipe from the top of the heat exchanger.
3. Remove the pipes to and from the engine cooling system.
4. Remove the pipes to and from the charge air cooler.
5. Remove the entire heat exchanger unit.
6. Unscrew the rear cover and remove the charge air cooler core with O-rings.
7. Remove the charge air cooler housing and the loose flange with O-rings.
8. Unscrew the intermediate piece with the sea water outlet.
9. Unscrew the front cover and remove the loose flange with O-rings.
10. Remove the cooler core for the main engine circuit.
11. Clean the outside of the cores. Use a paraffin-based engine cleaning agent.
12. Any internal deposits in the pipes can be removed mechanically using a round rod.
13. Lubricate all new O-rings.
14. Fit a new O-ring inside the main core flange and push the core into the housing.
15. Fit new O-rings on the end of the core with a loose flange between.
16. Fit the front cover and tighten the hexagon screws to 26 Nm.
17. Fit a new O-ring in the intermediate piece and screw this onto the heat exchanger, tightening to 26 Nm.
18. Fit the small heat exchanger housing on the stud bolts.
19. Fit a new O-ring inside the small core flange and push it into the housing.
20. Fit new O-rings on the end of the core with a loose flange between, and push the housing with core fully up to the intermediate piece.
21. Fit a new O-ring inside the small core flange and fit the rear cover. Tighten the flange nuts to 26 Nm.
22. Fit the complete heat exchanger to the engine and tighten the screws to 92 Nm.
23. Connect the sea water pipes and the radiator where fitted. Connect the pipes to the engine and charge air coolers.



Help protect our environment!

Use a container to avoid spills when changing the coolant. Dispose of used coolant through an authorised waste disposal contractor.



Important

The cooling system must never be cleaned with caustic soda. There is a risk of damage to aluminium parts.

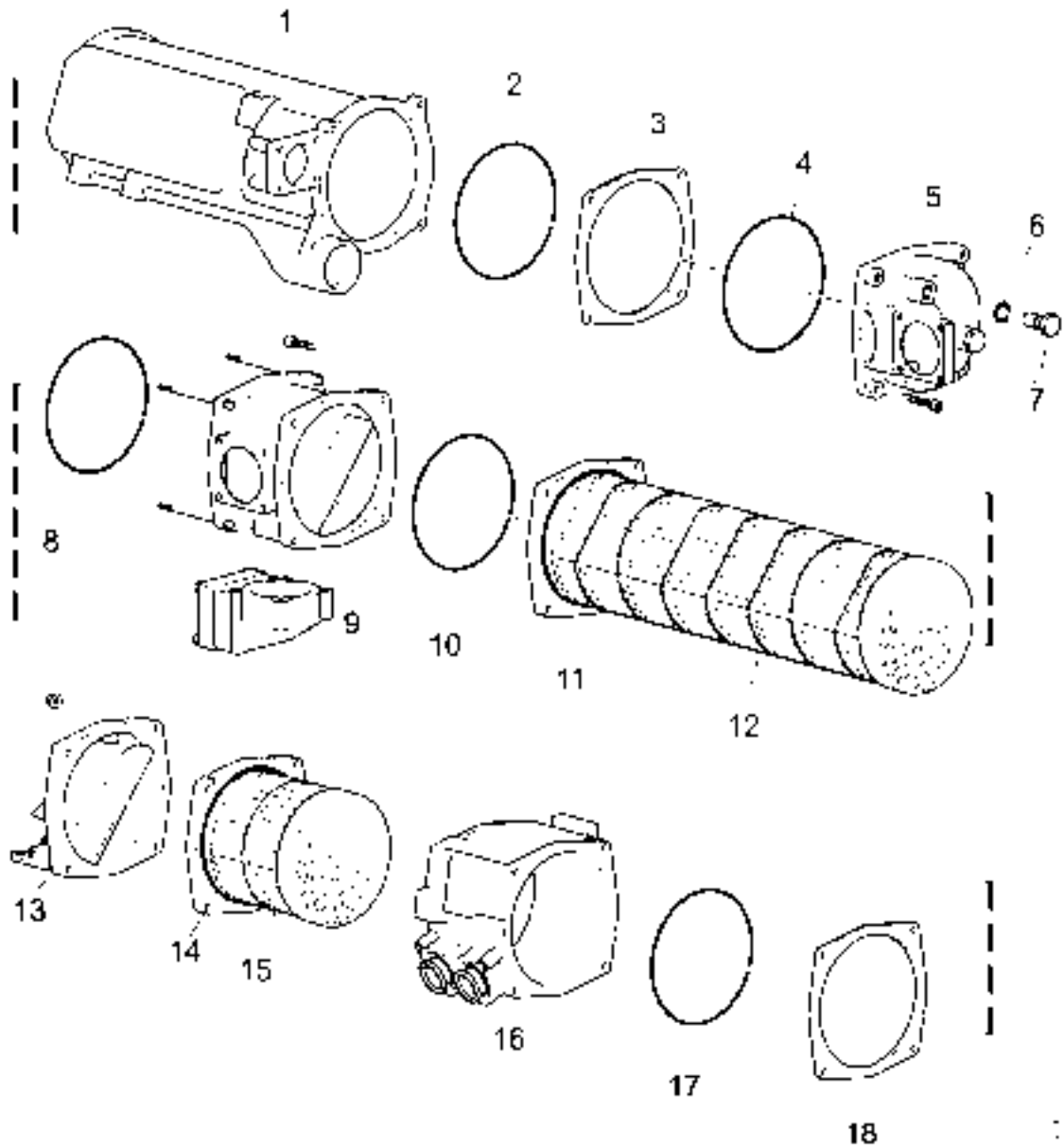

- | | |
|---|--|
| 1. Heat exchanger housing, main section | 12. Core, main section |
| 2. O-ring | 13. Rear cover |
| 3. Flange | 14. O-ring |
| 4. O-ring | 15. Core, charge air section |
| 5. Front cover | 16. Heat exchanger housing, charge air section |
| 6. Seal | 17. O-ring |
| 7. Sacrificial anodes | 18. Flange |
| 8. O-ring | |
| 9. Housing, intermediate section | |
| 10. O-ring | |
| 11. O-ring | |

Charge air cooler

1. Drain the coolant from the engine, see "Changing the coolant".
2. Remove the catwalk, belt guard and expansion tank.
3. Remove the air pipes from the turbochargers and the pipe between the charge air coolers.
4. Release the pipe connections for the coolant inlet and outlet on the charge air coolers.
5. Remove the closed crankcase ventilation valve where fitted.
6. Dismantle the charge air cooler according to the illustration.
Take care not to damage the core's water connections.
7. Clean the outside of the cooler core. Use a paraffin-based engine cleaning agent.
8. Fit a new gasket to the underside of the charge air cooler
9. Screw the core into the lower part. Tighten the screws to 26 Nm.
10. Fit the upper part of the charge air cooler. Tighten the screws to 50 Nm.
11. Refit the pipe connections for the inlet and outlet of the charge air coolers, and clamp the outlet pipe together with the thermostat housing to the charge air cooler.
12. Refit the air pipes from the turbochargers and the pipe between the charge air coolers.
13. Refit the expansion tank, catwalk and belt guard.



Help protect our environment!

**Use a container to avoid spills when changing the coolant.
Dispose of used coolant through an authorised waste disposal contractor.**

1. Intake manifold, upper part
2. Core
3. V-ring seal
4. O-ring
5. Pipe connection
6. Gasket
7. Intake manifold, lower part

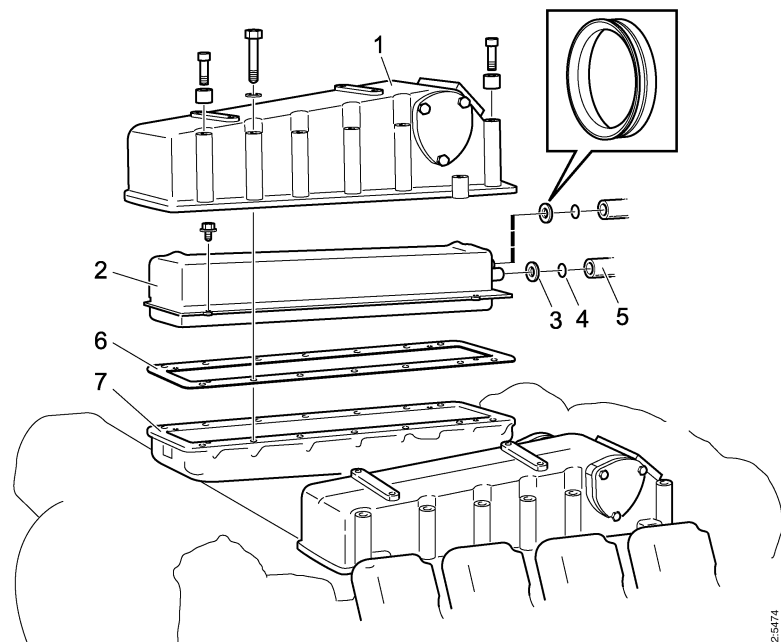

2-5174

Internal cleaning

Removing oil and grease

- If possible, run the engine until it has reached operating temperature and then drain the cooling system.
- Remove the thermostats.
- Fill the system with clean, hot water mixed with liquid dishwasher detergent designed for household use. Concentration 1% (0.1/10 l).
- Run the engine until warm for about 20-30 minutes. Remember the cab heating system, if fitted.
- Drain the cooling system.
- Fill the system again using clean, hot water and run the engine for about 20-30 minutes.
- Drain the water from the system.
- Refit the thermostats.
- Top up the system with new coolant according to the specification on page 33.



Help protect our environment!

Use a container to avoid spills when changing the coolant. Dispose of used coolant through an authorised waste disposal contractor.



WARNING

When handling cooling system detergent: read the warning text on the containers.

Removing deposits

- If possible, run the engine until it has reached operating temperature and then drain the cooling system.
- Remove the thermostats.
- Fill the system with clean, hot water mixed with some of the radiator cleaning agent available on the market which is based on sulphamic acid and contains dispersing agents. Follow the manufacturer's instructions for the concentration and cleaning period.
- Run the engine for the specified time and then drain the cooling system.
- Refill the system with hot water and run the engine for about 20-30 minutes.
- Drain the water from the system.
- Refit the thermostats.
- Top up the system with new coolant according to the specification on page 33.

Air cleaner

10. Daily:

Checking the read-out from the vacuum indicator

If the indicator's red plunger is fully visible, renew or clean the air cleaner filter element, see point 11. This is especially important if the engine is run with a heavy load or high engine speed.

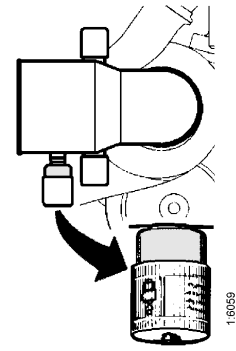

11. Every 1,200 hours:

Cleaning or renewing the filter element

Note: Earlier if the vacuum indicator shows red.

Dismantling

1. Remove the side cover from the air cleaner.
2. Renew or clean the element.

Note: Cleaning the element always entails a risk of damaging it. The element can only be cleaned a maximum of 4 times. After cleaning it has a poorer dust capacity than a new element.

3. Mark the filter when it has been cleaned.

Cleaning the element

- Carefully blow the filter element clean using dry compressed air from the inside.

Note: This filter element must not be washed with water.

!
Important

Only use genuine Scania air filters.

WARNING! Renew the filter element if it is damaged.

WARNING!



WARNING

Never start the engine without the air filter.

There is a risk of injury or serious engine damage.

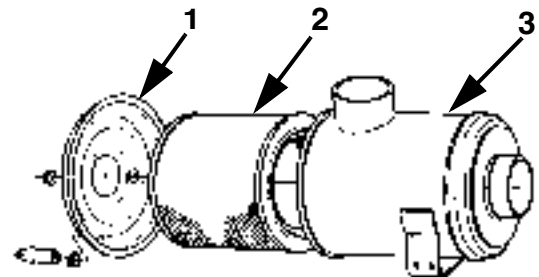

1. Cover
2. Filter element
3. Filter housing

Checks

- Insert a torch into the element and check from the outside that there are no holes or cracks in the filter paper.
- Renew the filter element if it has the slightest damage. Danger of engine damage.

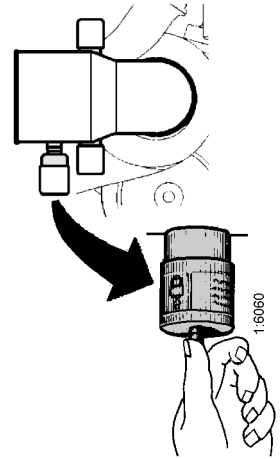

Assembly

1. Assemble the air cleaner in reverse order.
2. Reset the vacuum indicator by pressing the button.

Filter with a non-renewable element (unit cleaner)

Cleaning

- The filter may be cleaned a maximum of 3 times. Mark the filter after each time it has been cleaned.
 - Use a cleaning solution consisting of water mixed with approx. 1% mild detergent.
1. Pour the cleaning solution into the element outlet at the same time as turning the element so that the cleaning solution pours through the element against the direction of the air flow.
 2. Leave the element in the cleaning solution for 5 minutes and then take it out so that all the cleaning solution drains away.
 3. Rinse the filter with about 30 litres of clean water at 30-40°C. Pour the rinsing water through the element in the same way as you did the cleaning solution.
 4. Take out the element and allow the rinsing water to drain off.
 5. Repeat this procedure until the rinsing water is clean.
 6. Leave the element to dry in a warm place for approximately 24 hours.
 7. The filter must not be dried with compressed air.

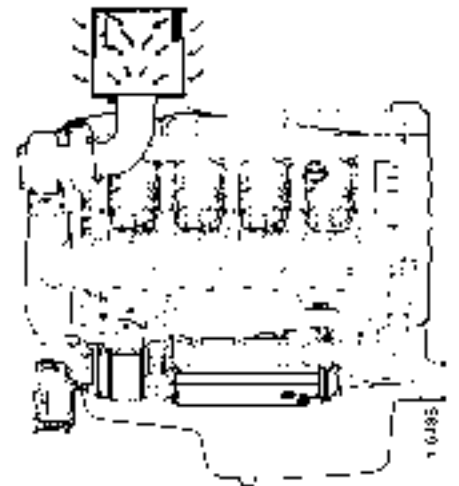

Fuel system

12. Daily:

Checking the fuel level

- Top up with fuel if necessary. At the same time, drain the water separating filter.
- If the tank has been run dry, bleed the fuel system, see point 13.



Important

Observe the utmost cleanliness when working on the fuel system.

There is a risk of engine malfunction and damage to the injection equipment.

13. Every 1,200 hours: Renewing the fuel filter

Fuel tanks

- Drain any water from the fuel tanks.

Main filter

The filter consists of a filter unit.

- Wash the outside of the filter and unscrew it.
- Fit the new filter and tighten it by hand.
Never use tools for this. The filters can be damaged, obstructing circulation.
- Bleed the fuel system according to the instructions overleaf.
- Start the engine and check for leaks.



Important

Use only genuine Scania fuel filters.



Help protect our environment!

Use a container to avoid spills when bleeding and renewing components.

Water separating filter

- Drainage must be carried out when filling fuel.
- The filter must be renewed at the same renewal interval as the main filter.
- Close the tap (1) before the filter.
- Unscrew the container and drain valve (3).
- Unscrew and renew the filter (2). Lubricate the seal before tightening the new filter by hand.
- Screw the container and drain valve into position.
- Open the tap (1).
- Bleed the fuel system after renewing both filters.

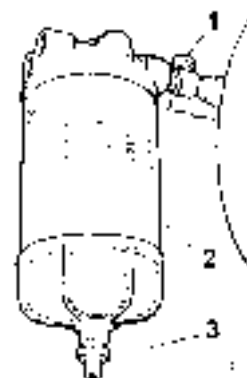

1. Shut-off cock
2. Filter
3. Drain valve



Help protect our environment!

Use a container to avoid spills when bleeding and renewing components.

Bleeding the fuel system

- Fit transparent plastic hoses on the bleed nipples of the fuel manifolds. Run the hoses to a container to collect the fuel.
- Open the bleed nipples and pump the hand pump (1) until the fuel flowing out of the nipples is free of air bubbles. This may take around 130-150 pump strokes.
- Close the bleed nipples and remove the hoses.
- Continue hand pumping until it feels tight.
- After renewing the fuel filter, it will take approximately 20 strokes.
- Approx. 50 pump strokes after renewing a unit injector.
- Start the engine and check for leaks.

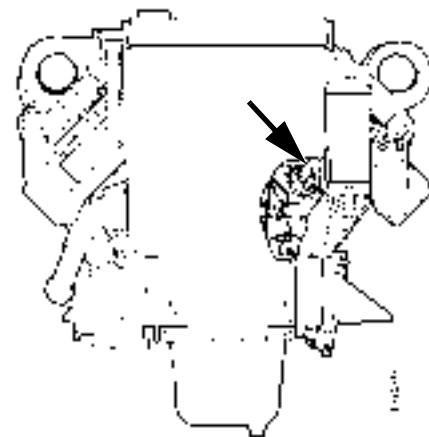

Important! *The starter motor may only be used for 30 seconds at a time. After that time it must rest for 2 minutes.*

If the engine fails to start after bleeding:

- Open the bleed nipples again and pump the hand pump until fuel without air bubbles flows out.
- Tighten the bleed nipples. Start the engine and check for leaks.

Electrical system

14. Every 200 hours:

Checking the electrolyte level in batteries

1. Unscrew the plugs and check the electrolyte level in all cells.
2. Top up with distilled water until the level is 10-15 mm above the plates.



WARNING

Avoid naked flames or sparks near the batteries.

When the batteries are charged, oxyhydrogen gas is formed which is flammable and explosive.

15. Every 1,200 hours:

Checking the state of charge in batteries

- Check the density with an acid tester.

In a fully-charged battery it should be:

- 1.280 at +20°C
- 1.294 at 0°C
- 1.308 at -20°C

- If the density is below 1.20, the battery must be charged. A discharged battery freezes at -5°C.

Do not boost charge the battery. This will damage the battery in the long run.



WARNING

Wear gloves and protective goggles when charging and handling batteries.

The batteries contain a highly corrosive acid.

16. Every 1,200 hours:

Cleaning batteries

1. Clean batteries, electrical cables and cable terminals.
2. Check that all cable terminals are firmly tightened.
3. Grease the battery terminals and cable terminals with Vaseline.



WARNING

Do not connect the terminals incorrectly.

This can cause serious damage to the electrical system.

If the terminals are shorted, sparking will occur.

Renewing the battery

Removing

1. Disconnect the negative cable (-) from the battery (electrical cable connected to earth).
2. Disconnect the positive cable (+) from the battery (electrical cable connected to starter motor).

Fitting

1. Connect the positive cable (+) to the battery (electrical cable connected to starter motor).
2. Connect the negative cable (-) to the battery (electrical cable connected to earth).



WARNING

Do not connect the terminals incorrectly. This can cause serious damage to the electrical system. If the terminals are shorted, sparking will occur.



Help protect our environment!

Dispose of used batteries through an authorised waste disposal contractor.

17. Every 1,200 hours: Checking the coolant level monitor (Optional equipment)

1. Start the engine.
2. Reduce the coolant level in the expansion tank to below the level monitor.
3. **Automatic stop in the event of a fault:** The engine stops, the indicator lamp comes on and the buzzer (if fitted) sounds if there is no fault in the level monitor. If the function is connected via the coordinator, the emergency stop fault code will be generated and can be read off on the diagnostics lamp.
4. **No automatic stop in the event of a fault:** The indicator lamp comes on and the buzzer (if fitted) sounds if there is no fault in the level monitor.
5. Top up coolant to the correct level, see page 31.

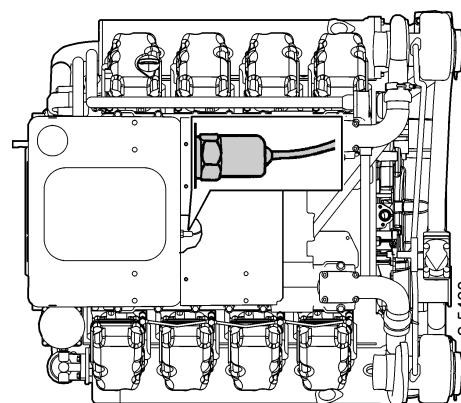

Level indicator in expansion tank



Help protect our environment!

Use a container to avoid spills when draining the coolant. Dispose of used coolant through an authorised waste disposal contractor.

Miscellaneous

18. Every 1,200 hours: Checking the drive belt

- If the drive belt (1), which is a poly-V belt, is worn or damaged it must be renewed.
- Also check that the automatic belt tensioner (2) is in proper working order and keeps the drive belt correctly tensioned.

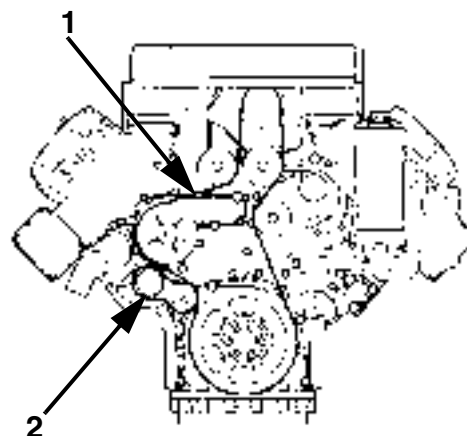

19. Daily:

Check for leaks, rectify as necessary

- Start the engine.
- Check for oil, coolant, fuel, air and exhaust leaks.
- Tighten or renew leaking connections. Check the overflow holes (1) in the block which show whether the O-rings between the cylinder liners and crankcase are leaking, see figure.
 - a) If coolant is running out, the O-ring is leaking.
 - b) If lubricating oil is running out, the liner shelf is leaking.
- Check that there are no leaks from the coolant pump. If there is a leak, renew the pump seal or the complete coolant pump.
- A small amount of leakage from the overflow holes during the engine running-in period is normal. Sealing rings and O-rings are lubricated with soap or oil when fitted.
- This leakage normally stops after a time.



Help protect our environment!

Take care to ensure that any leaks do not cause pollution.



Important

If serious leakage occurs, contact your nearest Scania workshop.

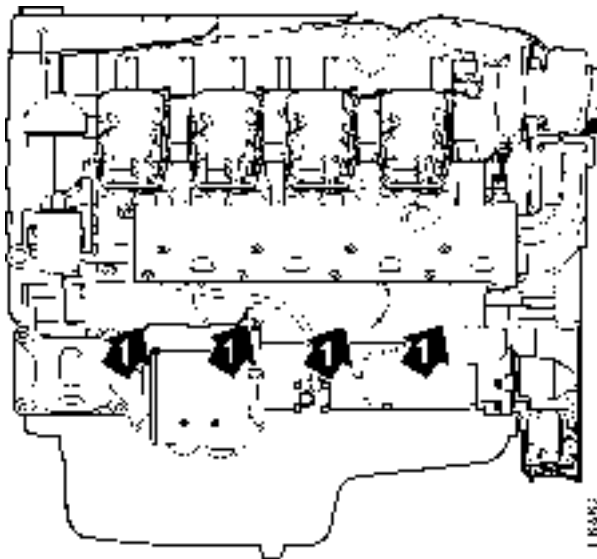

20. Every 2,400 hours: Checking and adjusting the valve clearance

Note: Checking and adjusting valve clearances should also be done after the first 400 hours of operation.

Valve clearances should be adjusted when the engine is cold, at least 30 minutes after running.

The rocker cover gaskets should be renewed as necessary. Tightening torque: 26 Nm.

Intake valve clearance: 0.45 mm.
Exhaust valve clearance: 0.70 mm.

Tightening torque for lock nut: 35 Nm

Order of adjustment

- Turn the flywheel so that the marks on the flywheel can be seen in the lower opening in the flywheel casing.
- Measure the valve clearance with a feeler gauge and adjust the valves as per the order of adjustment in the table below. The correct valve clearances are also given on the instruction plate on one of the rocker covers:

Mark on flywheel	Valve transition on cylinder	Adjust intake valves on cylinder	Adjust exhaust valves on cylinder
TDC Down (0°)	6	7 and 8	4 and 5
TDC Up (180°)	7	1 and 5	2 and 6
TDC Down (360°)	1	2 and 4	3 and 7
TDC Up (540°)	4	3 and 6	1 and 8



WARNING

Block the starting device when working on the engine.

If the engine starts unexpectedly, there is a SERIOUS RISK OF INJURY.

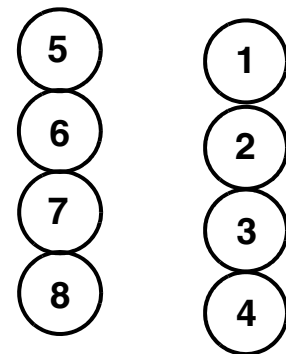

FLYWHEEL

Cylinder numbering

21. Every 2,400 hours Checking and adjusting the unit injector rocker arms

Note: Checking and adjusting the unit injector rocker arms should also be done together with the valve clearance check and adjustment after the first 400 hours of operation.

Important! The PDE31 unit injector is adjusted using setting tool 99 414 or a digital sliding caliper. The PDE32 unit injector is adjusted using setting tool 99 442 or a digital sliding caliper. This adjustment is essential as a fault in the position of the unit injector can result in poor performance and possible breakdown.

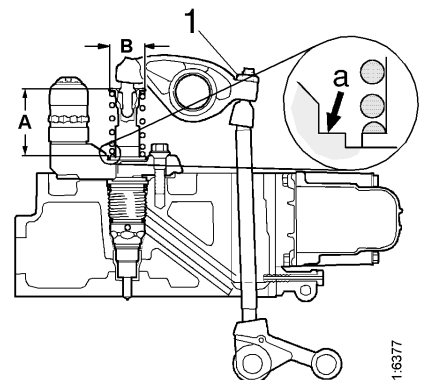

Dimension A=PDE31: 66.9 ± 0.1 mm
PDE32: 69.9 ± 0.1 mm

Dimension B=PDE31: 36.5 mm
PDE32: 38.8 mm

PDE31:

1. First, measure the distance (A) between plane (a) and the top edge of the valve spring collar on the unit injector using a digital sliding calliper. See figure.
2. Dimension (A) should be 66.9 mm for PDE31 (dimension B=36.5 mm).
3. The dimension is adjusted by undoing the lock nut and screwing the rocker arm adjusting screw (1) to the correct measurement.

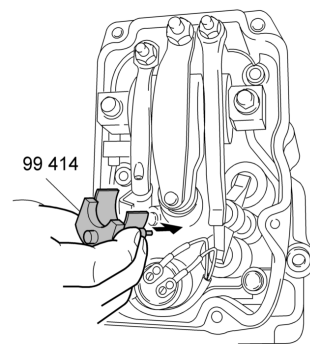

WARNING! Take care when carrying out the adjustment if the dimension is well outside the adjustment dimension. The spring is pre-tensioned and can cause personal injury if it is released.

4. Position setting tool 99 414 with the metal plate around the injector spring.
5. Finely adjust dimension (A) by simultaneously using a finger to sense that the small piston (2) is level with the flat upper surface of the tool. It is possible to feel differences of less than a tenth of a millimetre.
6. If the setting tool is not available, a digital sliding caliper can also be used for fine adjustment. The rocker position is adjusted using the adjusting screw to 66.9 ± 0.1 mm as stated above.
7. Tighten the adjusting screw lock nut to 39 Nm and remove the tool.
8. The order in which the injector rocker arms are to be checked/adjusted is shown in the table below.

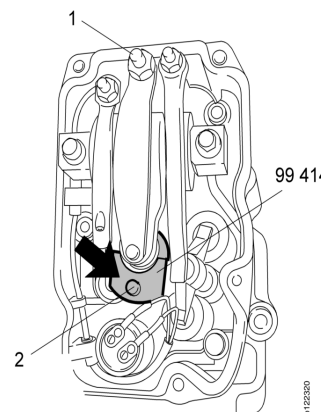

Note: Additional checking and adjustment of the PDE injectors, e.g. checking the opening pressure, must not be carried out. Faulty injectors must always be replaced completely.

Order of adjustment:

- Turn the flywheel so that the marks on the flywheel can be seen in the lower opening in the flywheel casing.

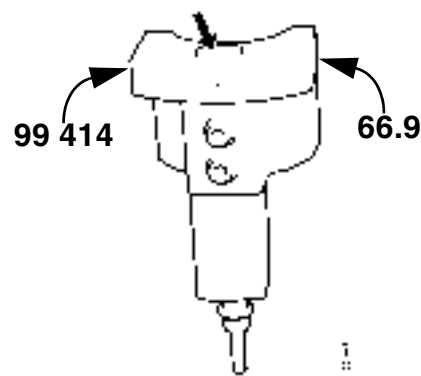

Piston above or below the flat surface. Adjustment necessary

Mark on flywheel	Valve transition on cylinder	Adjust injector rocker arm on cylinder
TDC Down (0°)	6	4 and 5
TDC Up (180°)	7	2 and 6
TDC Down (360°)	1	3 and 7
TDC Up (540°)	4	1 and 8

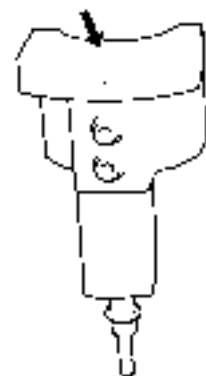

Piston level with the flat surface. The adjustment is correct

PDE32:

1. First, measure the distance (A) between plane (a) and the top edge of the valve spring collar on the unit injector using a digital sliding calliper. See figure.
2. Dimension (A) should be 69.9 mm for PDE32 (dimension B=38.8 mm).
3. The dimension is adjusted by undoing the lock nut and screwing the rocker arm adjusting screw (1) to the correct measurement.

WARNING! Take care when carrying out the adjustment if the dimension is well outside the adjustment dimension. The spring is pre-tensioned and can cause personal injury if it is released.

4. Position setting tool 99 442 with the metal plate around the injector spring.
5. Finely adjust dimension (A) by simultaneously using a finger to sense that the small piston (2) is level with the flat upper surface of the tool. It is possible to feel differences of less than a tenth of a millimetre.
6. If the setting tool is not available, a digital sliding caliper can also be used for fine adjustment. The rocker position is adjusted using the adjusting screw to 69.9 ± 0.1 mm as stated above.
7. Tighten the adjusting screw lock nut to 39 Nm and remove the tool.
8. The order in which the injector rocker arms are to be checked/adjusted is shown in the table below.

Note: Additional checking and adjustment of the PDE injectors, e.g. checking the opening pressure, must not be carried out. Faulty injectors must always be replaced completely.

Order of adjustment:

- Turn the flywheel so that the marks on the flywheel can be seen in the lower opening in the flywheel casing

Mark on flywheel	Valve transition on cylinder	Adjust injector rocker arm on cylinder
TDC Down (0°)	6	4 and 5
TDC Up (180°)	7	2 and 6
TDC Down (360°)	1	3 and 7
TDC Up (540°)	4	1 and 8

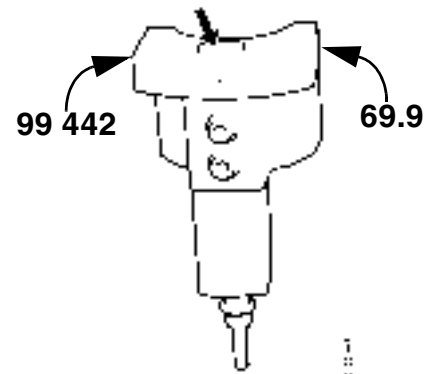

Piston above or below the flat surface. Adjustment necessary

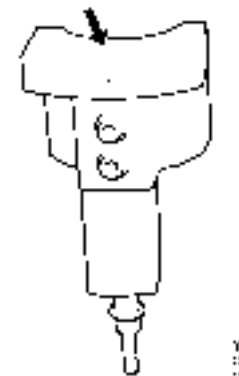

Piston level with the flat surface. The adjustment is correct

Preparing the engine for storage

If the engine is not to be used for a lengthy period of time, special measures should be taken to protect the cooling system, fuel system and combustion chamber from corrosion and the exterior from rusting.

The engine can normally stand idle for up to 6 months. If it remains unused for longer than this the following measures, which provide protection for about 4 years, should be adopted. An alternative to preparing the engine for long-term storage is to start the engine and warm it up every 6 months.

Preparing the engine for storage means:

- Thoroughly cleaning the engine.
- Running the engine for a certain time using special preservative fuel, oil and coolant.
- Otherwise preparing the engine for storage (filter renewal, lubrication, etc.).

Preservative coolant

If the engine is to be stored with a full cooling system, use coolant containing 50 percent glycol by volume. Glycol without nitrite-based inhibitor should be used. E.g. **BASF G48** or **BASF D542**



WARNING

Ethylene glycol can be fatal if ingested. Avoid contact with the skin.

Preservative fuel

- Use diesel mixed with Lubrizol 560H or the equivalent.
- Mix 1 cm³ (ml) of Lubrizol 560H in 10 dm³ (l) of fuel.



HANDLING LUBRIZOL 560H

Hazardous!

Contains aromatic hydrocarbons

Use spot extractors where there is a danger of vapour build-up.
Wear protective gloves and goggles when handling Lubrizol. Do not use contaminated clothing.

If it gets in your eyes: Rinse with a gentle stream of water (at least 15 minutes). Seek medical attention.

If it gets on your skin: Wash the affected area with soap and water

If you inhale it: Fresh air, rest and warmth

Flammable: Fire class 2A. Flashpoint +27°C.
In the event of fire: Extinguish with carbon dioxide, powder or foam

Storage: In a well-sealed receptacle in a dry, cool place. **Keep out of reach of children.**

Preservative oil

Suitable preservative oils are available from most oil companies, e.g. Dinitrol 40 or the equivalent.

Preparations for storage

- Drain and flush the cooling system. Top up with preservative coolant.
- Warm up the engine on normal fuel. Stop the engine and drain the oil.
- Renew the fuel filter.
- Fill the engine with preservative oil up to the minimum level on the dipstick.
- Mix preservative fuel in a can. Detach the fuel pipe at the feed pump suction line and connect a hose from the can.
- Detach the fuel pipe at the overflow valve and connect a return hose to the can.
- Start the engine and run it at about 1,000 rpm (not single-speed engines) for 20-25 minutes.
- Stop the engine, remove the hoses and connect the normal fuel lines.
- Remove the rocker covers and lubricate the valve mechanisms and PDE mechanisms with preservative oil. Refit the rocker covers.

Note: The unit injectors must not be removed.

- Drain the preservative oil from the engine. Fresh engine oil can be filled directly or when preparing the engine for use.
- Drain the coolant if the engine is not to be stored with coolant in the system. Plug and tape over all coolant connections (if the cooling system is not completely assembled).
- Drain the sea water system.
- Air cleaner: clean or renew the filter element.
- Cover air intakes and exhaust pipes.
- Alternator and starter motor:
 - Spray with water-repellent anti-corrosive oil, CRC 226, LPS1 or the equivalent.
- Spray the outside of bright engine parts, first with penetrating preservative oil such as Dinitrol 25B and then with Dinitrol 112 or the equivalent.

Winter storage

- To reduce the risk of condensation in the fuel tank during winter storage, fill the tank with fuel.



Help protect our environment!

Use a container to avoid spills when draining the oil and coolant. Dispose of used oil and coolant through an authorised waste disposal contractor.

- *Attach a label to the engine, clearly stating the storage preparation date and that the engine must not be started or cranked.*

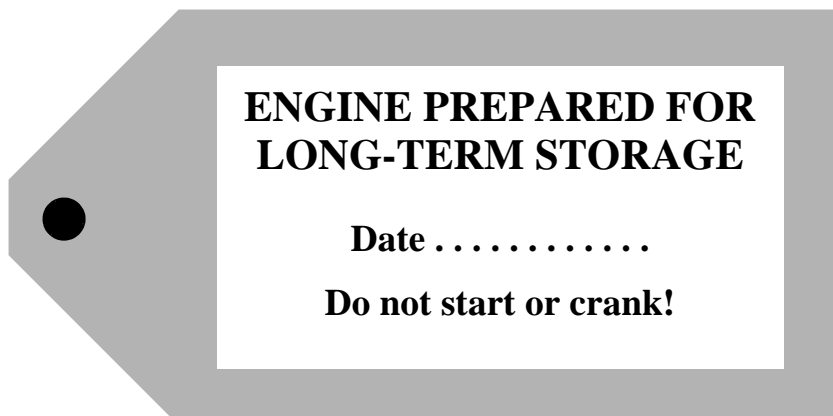

Batteries

Remove the batteries for trickle charging at the battery charging station. This does not apply to batteries specified as maintenance-free by the manufacturer. The same applies to short-term storage, even if the engine has not been prepared for storage as above.

Storage

After the preparations, the engine should be stored in a dry and warm place (room temperature).

Preparation for use

(Procedure for taking the engine into operation)

- Remove plugs and tape from coolant connections, air intakes and exhaust pipes.
- Fill the system with coolant, see page 18.
- Connect the sea water system.
- Check the oil level in the engine or top up with fresh engine oil.
- Lubricate the valve mechanisms and their pushrods and valve tappets as well as the PDE injector mechanisms.
- Drain the preservative fuel from the fuel manifolds and fuel filter.
- Connect and bleed the fuel system, see page 43.
- Wash off any externally applied preservative oil using white spirit.



WARNING

Wear gloves and protective goggles when charging and handling batteries.

The batteries contain a highly corrosive acid.

Technical data

General	DI16
Number of cylinders	8 (V8, 90°)
Cylinder diameter mm	127
Piston stroke mm	154
Displacement dm ³ (litre)	15.60
No. of main bearings	5
Firing sequence	1 - 5 - 4 - 2 - 6 - 3 - 7 - 8
Compression ratio	16:1
Engine direction of rotation viewed from rear	Anti-clockwise
Fan direction of rotation viewed from front	Clockwise
Cooling	Liquid
Valve clearances, cold engine	
intake valve mm	0.45
exhaust valve mm	0.70
Weight with heat exchanger, without coolant or oil kg	1,550
Power	See "Engine record card"
Lubrication system	
Max. oil pressure warm engine running at a speed above 1,000 rpm bar (kp/cm ²)	6
Normal oil pressure warm engine at operating speed bar (kp/cm ²)	3-6
Min. oil pressure warm engine 1,000 rpm bar (kp/cm ²)	3.0
Min. oil pressure warm engine, idling bar (kp/cm ²)	1.4
Oil capacity, see page 27	
Crankcase pressure with closed crankcase ventilationmm water column	-55 - +20

Fuel system		DI16
Low idling	rpm	700 (adjustable 500-800)
Maximum full load speed		See engine card
Fuel		Diesel ¹
¹ see page 56		
Cooling system		
Number of thermostats		1 (dual thermostat)
Thermostat, opening temperature	°C	79
Coolant temperature:		
system at atmospheric pressure	°C	70-93
system at overpressure	°C	70 - approx. 100
Volume including heat exchanger and expansion tank		95
Electrical system		
System voltage	V	24
Alternator, current	A	140
Starter motor output	kW (hp)	6.7 (9.1)
Monitors, threshold values:		
oil pressure monitor	bar (kp/cm ²)	1.0 ± 0.15
temperature monitor	°C	Stamped on hexagonal part of monitor

Fuel

Diesel

The composition of the diesel is very important for the operation and service life of the engine and injection system. The engine output and exhaust emissions are also dependent on the fuel quality. The requirements and testing standards for the most important properties are described in the Workshop Manual in sections which can be ordered from Scania dealers or directly from Scania. Scania's address is printed on the cover.

Diesel must comply with the following standard: EN 590 (European standard).

The table below shows the requirements for some of the most important properties.

Property	Requirements
Viscosity at 40°C	2.0-4.5 mm ² /s (cSt)
Density at 15 °C	0.82-0.86 kg/dm ³
Sulphur (concentration by mass)	max 0.3%
Ignitability (CET rating)	min. 49
Flashpoint	56°C

Biofuel (low sulphur fuels)

There are 3 different classes of biofuels (SS15 54 35).

Class 1 is sulphur-free and class 2 is low in sulphur. Compared with class 3 (normal fuel), these fuels are less dense and this reduces engine power. Only class 1 fuel should be used with a catalytic converter.

Short term use of fuel with a higher sulphur content than 0.05% by weight will not cause permanent damage to the catalytic converter.

The catalytic converter may, however, require fuel with a low sulphur content for some time after this to regain its normal efficiency.

Temperature dependence of diesel

At temperatures lower than those specified for the diesel, paraffin wax may precipitate from the fuel and block filters and pipes. The engine can then lose power or stop.

The diesel is adapted for use in the specific climate of each country. If a vehicle or an engine is to be operated in a temperature zone with lower temperature than normal, first identify the temperature properties of the fuel concerned.

The properties of the fuel when cold can be improved by adopting one of the following measures before the temperature drops:

- If the fuel concerned cannot cope with the expected temperatures, and diesel is not available with the correct temperature properties, Scania recommends that an electric fuel heater is installed as a preventive measure.
- The low temperature properties of diesel may be improved by adding kerosene as a preventive measure. A maximum of 20% may be added. When refuelling, the kerosene should be added first, so that it mixes thoroughly with the diesel.

Note: It is prohibited to use kerosene in engine fuel in some countries.

- To prevent water in the fuel from freezing and forming ice, a maximum of 0.5-2% alcohol (isopropanol) may be added.

Drain fuel tanks and drain or renew fuel filters regularly.

!

Important

It is not permitted to mix kerosene with diesel that is already adapted for the climate concerned. The injection equipment may be damaged. All use of paraffin other than kerosene is forbidden, as it causes engine damage.

!

Important

It is not permissible to mix petrol with diesel. Petrol may cause wear to the unit injectors and it may also cause damage to the engine.

EC declaration of conformity

The following declaration of conformity applies to the DI16 45M with an engine output of 662 kW. The declaration guarantees that the engine is classified as suitable for recreational craft according to directive 94/25/EC.

DECLARATION OF CONFORMITY

With requirements of Council Directive 94/25/EC as amended by 2003/44/EC and 88/356/EC

ENGINE MANUFACTURER: Scania CV AB
 ADDRESS: SE - 131 87 Södertälje
 COUNTRY: Sweden
 NOTIFIED BODY FOR RCD: DNV, Det Norske Veritas
 ADDRESS: Veritasgaten 1, 1322 Høvik
 COUNTRY: Norway
 ID NUMBER: 0573
 CERTIFICATE: QS - Certificate of Assessment - EC
 ENGINE TYPE: Scania Marine Inboard Engine, 4 Stroke
 FUEL TYPE: Diesel
 MODULE: Module H (Annex XII) is used for conformity assessment to 94/25/EC as amended by 2003/44/EC

SERIAL NUMBER

The following engine(s) meet the exhaust emission requirements of council directive 94/25/EC as amended by 2003/44/EC, when installed in a recreational craft, in accordance with Scania CV supplied instructions. The engines must not be placed into service until the recreational craft into which it is to be installed has been declared in conformity, if so required, with the relevant provisions of the above Directive.

DESCRIPTION OF REQUIREMENTS

REQUIREMENTS	TECHNICAL FILE	RELEVANT STANDARDS	HARMONIZED STANDARDS
Engine power measurement			EN ISO 8665-1:1995/A12000
Emission requirements			EN ISO 8176-1:1996
Inboard Diesel engine			EN iso 16147:2002
Electromagnetic compatibility	105-0174	EN 55012:2002	

Covered Engines

TYPE DESIGNATION	CERTIFICATE NUMBER RCD	CERTIFICATE NUMBER EMC
Scania DI1645M	RCD - H - 3	E014 - TR.050117

Scania Industrial and Marine Engines hereby declare that the engine(s) listed above conform to European Union Directives, standards and normative documents identified in this declaration.

Name: Robert Sobocki
 Senior Vice President
 (Person empowered to sign on behalf of engine manufacturer)

Signature: 

Date (Year/Month/Day): 2012-05-30

334 804

Alphabetical index

Air cleaner	40	Oil level	27
Air cleaner, vacuum indicator	40	Oil pressure	22
Air filter, element	40	Preface	2
Batteries	44	Preparation for use	53
Battery, renewing	45	Preparations for storage	51
Bleeding, fuel system	43	Running	20
Certified engines	5	Safety information	6
Checks after running	23	Safety precautions for care and maintenance ..	8
Checks before running	19	Safety precautions for handling materials	8
Coolant	33	Safety precautions for running the engine	7
Coolant level	31	Starting the engine	19
Coolant level monitor	45	Stopping the engine	23
Coolant temperature	21	Storage	53
Coolant, changing	35	Technical data	54
Cooling system	31	Troubleshooting, control unit	14
Cooling system, cleaning	36	Troubleshooting, coordinator	16
Corrosion inhibitor	35	Type designations	10
Drive belt	46	Unit injector	48
Electrical system	44	Vacuum indicator	40
EMS sensors	13	Valve clearance	48
Engine speed	20	Warranty	1
Environmental responsibility	4		
Filter, air cleaner	40		
Filter, fuel	42		
First start	18		
Flash codes, control unit	15		
Flash codes, coordinator	17		
Fuel filter, renewing	42		
Fuel level	42		
Fuel specifications	56		
Fuel system	42		
Fuel system, bleeding	43		
Glycol	33		
Inspection schedule	25		
Leakage	47		
Lubricating oil pressure	22		
Lubrication system	26		
Maintenance	24		
Oil analysis	26		
Oil capacity	27		
Oil change	27		
Oil filter	28		
Oil filter	30		
Oil grade	26		

Scania Assistance

Wherever you are, you can always get assistance from the Scania service organisation, Scania Assistance, all day, every day of the year. Using Scania Assistance is free, but the cost of repairs, spare parts and help from mechanics will be debited.

Always call the contact for your country.

AR	0800 999 722 642	IE	+353 71 9634000
AT	+43 1 256 44 11	IT	+39 0461 996 222
AU	1300 SCANIA 1300 722642	KR	+82 1588 6575
BE	+32 2 264 00 00	LU	+32 226 400 000
BG	+359 886 660001	MA	+34 91 678 92 13
BR	0800 019 42 24	MX	01 800 4SCANIA
CH	+41 800 55 24 00	NL	+31 70 4182666
CL	188 800 722 642	NO	+47 223 217 00
CZ	+420 225 020 225	PL	+48 602 622 465
DE	+49 261 887 8888	PT	+48 91 678 9247
DK	+45 333 270 44	RO	+40 723 27 27 26
ES	+34 91 678 80 58	SE	+46 42 100 100
FI	+358 10 555 24	SK	+421 903 722 048
FR	+33 2 414 132 32	TR	+90 212 335 04 40
GB	0 800 800 660 +44 1274 301260	TZ	+255 78 472 2642
GR	+30 6944 420 410	UY	0800 8351
HU	+36 209 727 197	ZA	0800 005 798 +27 11 661 9823

Other countries: +46 8 52 24 24 24

Note: Calls will be recorded for training purposes.