

**OWNER'S MANUAL**  
**BENETEAU 323**

**HULL IDENTIFICATION NUMBER:**

**US-BEY** \_ \_ \_ \_ \_

OWNER'S MANUAL BENETEAU PART #: 112746

**TABLE OF CONTENTS:**

I)	INTRODUCTION.....	3
II)	ANTI-FOULING.....	4
III)	LIMITED WARRANTY.....	5
IV)	HULL IDENTIFICATION NUMBERS .....	7
V)	DEALER'S RESPONSIBILITIES .....	7
VI)	OWNER'S/OPERATOR'S RESPONSIBILITIES.....	8
VII)	SAFE OPERATION AND WARNING LABELS .....	12
VIII)	FEDERAL/STATE REGULATIONS.....	17
IX)	COMMISSIONING .....	20
X)	SPECIFICATIONS OF THE BOAT.....	24
XI)	INTERIOR LAYOUT .....	26
XII)	DECK .....	28
XIII)	SAILS AND RIGGING.....	29
XIV)	FRESH WATER SYSTEM.....	42
XV)	BILGE PUMP SYSTEM.....	44
XVI)	SEACOCKS AND THRU-HULLS.....	47
XVII)	MARINE TOILET & HOLDING TANK .....	49
XVIII)	ELECTRIC SYSTEMS .....	53
XX)	LP GAS SYSTEM.....	63
XXI)	STEERING SYSTEM .....	66
XXII)	ENGINE .....	68
XXIII)	HANDLING.....	73
XXIV)	MAINTENANCE OF YOUR BOAT.....	74
XXV)	WINTERIZING PROCEDURES .....	80
XXVI)	ENVIRONMENT.....	85

**EXPLANATION OF THE TYPOGRAPHY USED:**

**DANGER**

**WARNING**

**TAKE CARE**



## D) INTRODUCTION

**Many parts and systems installed on your boat are supplied by other manufacturers and each carries a specific warranty and may require specific care.** This manual supplements the literature supplied with the various equipment and we will refer to manufacturer's literature throughout this booklet. We recommend referring to original manufacturer's literature whenever possible.

This manual is broken down into several sections that attempt to help explain your boat, your warranty, responsibilities as an owner, and maintenance of your new Beneteau. Some of the equipment described in this manual are offered as options. The systems and procedures described in this manual were correct to the best of our knowledge at the time of printing and may be changed at any time or may have been changed on your boat. While we have tried to describe the major points of your boat within this book, we cannot cover every detail. Owning a boat and the operation of it are complex issues that can only be mastered by vast experience and professional assistance. Please call your dealer or feel free to call us if any question should arise.

If you are a seasoned sailor much of the manual may be old news, and if this is your first boat, we hope this will prove useful, but we advise you to seek out professional instruction through your dealer, sailing schools, the US Coast Guard auxiliary, US Power Squadron, etc.

Should you need to contact Beneteau please use the following addresses and numbers, be sure to include your model and hull identification number with any correspondence.

### **Beneteau Customer Service**

(Customer Service Dept.)  
1313 Highway 76 West  
Marion, SC 29571  
Tel (843)-629-5300  
Fax (843)-629-5329

We would like to sincerely thank you for choosing a Beneteau and we wish you good sailing.

**NOTE:** Specifications, dimensions, capacities and descriptions are estimations given for general information purposes, and they are not contractual in nature.



## II) ANTI-FOULING

The primary function of your Beneteau is to maximize your boating pleasure. Your new Beneteau was made to last for many years. From the very beginning, care has been taken in building your boat. Your years of pleasurable ownership are dependent upon proper care and preparation.

Between the gel coat and the fiberglass laminate, Beneteau applied a Vinylester resin that greatly reduces the phenomenon of osmosis and osmotic blistering. All materials used in the construction of your Beneteau are of high production quality. Sampling of materials and operational standards are monitored so that the structural design matches the engineered standard. This, coupled with the mastery of building techniques, allows Beneteau USA to offer you one of the most favorable structural warranties in the marine industry.

### Methodology for anti-fouling application when new:

1. Clean and degrease hull thoroughly using a denatured ethyl alcohol
2. Sand hull using sandpaper with a minimum grit of #220. (i.e., 220, 300, or 400)
3. Rinse with fresh water.

**DO NOT USE DETERGENTS. DO NOT PRESSURE WASH.**

4. **APPLY ANTI-FOULING TO MANUFACTURER'S DIRECTIONS.**

**NOTE: It cannot be emphasized enough that thorough de-waxing must occur. Furthermore, if the gel coat is abraded with coarse sandpaper, the water imperviousness will be destroyed, and the warranty might be voided.**

### III) LIMITED WARRANTY

Beneteau USA Inc. ("Beneteau USA") warrants to the original purchaser or any subsequent buyer during the time of this Limited Warranty (the "Owner"), that the boat, excluding parts or accessories not manufactured by Beneteau USA or Chantiers Beneteau, S.A., will be free from defects in material and workmanship for a period of ONE year from the date of the delivery to the original purchaser.

In addition, Beneteau USA warrants to the Owner, except for the prototypes and boats from the California series, that the hull and deck structure of the boat will be free from defects in material and workmanship for a period of FIVE years from the earliest of the following events: delivery of the boat to the original purchaser, first date of utilization, last day of the boat model year.

Beneteau USA's obligation under this warranty shall be limited to the repairing or replacing (or causing to be repaired or replaced), at Beneteau USA's option, the part or parts which are recognized defective by it in material or workmanship within the applicable warranty period to the exclusion of all other remedies. This Warranty shall apply only provided that the Owner presents the boat's Certificate of Origin and gives the selling dealer written notice of any claimed defect within 15 days after such defect is first discovered and satisfactory proof thereof. Warranty repairs do not result in a renewal or extension of the original Warranty for the boat or a part thereof. Transportation charges and duties shall be borne by the Owner.

This Warranty does not extend to: (1) any losses due to misuse, accident, disaster, abuse, neglect, normal wear and tear or improper maintenance; (2) boats or any part thereof which have been repaired or altered without Beneteau USA's prior written approval; (3) accessories or parts not supplied by Beneteau USA or Chantiers Beneteau, S.A., or parts or accessories installed during the process of manufacturing that were not manufactured by Beneteau USA or Chantiers Beneteau, S.A., for which the Warranty will be the one provided by the supplier of the part or accessory; (4) damages resulting from any modification made to the boat; (5) boats for rental, lease, or charter; (6) splits, discoloration, or cracks in the gel-coat (hull, rudder, and deck); (7) disorders in the hull, or deck such as, without limitation, blisterings, which are caused by use of improper maintenance products or by improper sanding of the gel-coat; (8) anti fouling, varnishes, paints, acrylon, naugahyde, fabrics, headliners, chrome, anodized coatings, keel coatings, sails, cushions, or running rigging, as these items are subject to deterioration caused by climate, erosion, normal use conditions, or wear and tear; (9) reasonable and necessary maintenance, including, but not limited to, periodic re-bedding of chain plates, stanchion bases, windows and/or window frames, and winches; (10) damages or deterioration due to the non-observance of maintenance recommendations as described in the owner's manual or non-compliance with the normal rules of boat maintenance; (11) failure to take reasonable measures necessary to protect the boat; (12) any damage or deterioration to the boat resulting from participation in a competitive sporting event.

In addition, if (1) any structural damage to the boat is suffered as a result of any cause other than a defect in material or workmanship (whether or not such damage requires or results in any repairs to the hull or deck), or (2) any repairs or alterations to the boat of any nature whatsoever are made at a shipyard not approved in writing by Beneteau USA, then the five-year hull/deck Warranty set forth above will immediately thereupon terminate and be of no further force or effect.

THIS WARRANTY IS EXPRESSLY IN LIEU OF ALL OTHER WARRANTIES EXPRESS OR IMPLIED INCLUDING WITHOUT LIMITATION THE IMPLIED WARRANTIES OF MERCHANTABILITY OR FITNESS FOR A PARTICULAR PURPOSE AND ALL OTHER LIABILITIES ON BENETEAU USA'S PART, AND BENETEAU USA NEITHER ASSUMES, NOR AUTHORIZES ANY PERSON, INCLUDING THE DEALER, TO ASSUME FOR IT, ANY OTHER LIABILITY IN CONNECTION WITH THE SALE OF BENETEAU USA'S BOATS.

Beneteau shall in no event be liable to the Owner or any other person or entity for damages of any kind, including but not limited to direct, indirect, special or consequential damages, arising from the sale or in connection with the use or inability to use the boat for any purpose whatsoever, irrespective of whether the claims or actions for such damages are based upon contract, tort, negligence, strict liability, warranty, or otherwise.

For the purpose of compliance with the Federal Boat Safety Act of 1971 and all notification procedures set forth therein, Beneteau USA requests that you complete the information requested below concerning your current address, which shall be returned to Beneteau USA by your Dealer.

Beneteau USA reserves the right, at any time, to make changes in design or additions to or improvements in the boats without liability or obligation to incorporate such change, addition, or improvement in any boat manufactured prior thereto.

This Warranty gives you specific legal rights. You may also have other rights which vary from state to state.

I hereby acknowledge that Beneteau USA Inc. Limited Warranty was attached to Dealer's purchase order in its entirety at the time that I purchased my boat from said Dealer; that I have read such Limited Warranty in its entirety; and that I have a copy of such Limited Warranty, as attached to Dealer's purchase order, for future reference.

Signature _____	Boat Model _____
Purchaser's Name/Please Print Clearly _____	Hull # _____
Mailing Address of Purchaser _____	Dealer _____
City State Zip _____	Date _____
(Area Code) _____	Telephone Number _____

## WARRANTY/REGISTRATION PROCEDURES

### Warranty Procedure

Beneteau boats, unless specifically excluded, carry a one year limited warranty, as well as an extended hull and deck structural warranty (see official warranty form for details). As the first owner of your new Beneteau, your warranty only becomes valid upon receipt, by Beneteau, of the completed and signed warranty form. **It is important that you were presented with this document at the time of your contract with your dealer and that both you and your dealer have signed this form. Your warranty will then take effect upon delivery to you of your new Beneteau.**

### Registration Procedure

As a new Beneteau owner you will automatically become a member of Club Beneteau. Club Beneteau will entitle you to many added benefits and advantages as well as providing you with a valuable line of communication with Beneteau. We will forward a new owner's package directly to 30 day after receipt of the completed and signed warranty form from your dealer.

Subsequent owners of Beneteaus are invited to become a member of Club Beneteau as well. We will automatically enroll these boat owners upon receipt of their warranty transfer cards.

In the event that you change your address, please fill out and mail in the change of address card at the back of the manual (to the address below) so that you will not miss any of Club Beneteau's opportunities. You can also find a change of address form on line under CLUB BENETEAU at [www.beneteauusa.com](http://www.beneteauusa.com).

If you have any questions concerning this procedure please feel free to contact Beneteau Customer Service at at the number below.

### Warranty Transfer

For a period of five years from date of manufacture, your new Beneteau has a transferable, limited hull and deck warranty. In the event of selling your Beneteau, the new owner must be registered with Beneteau within 30 days of the date of sale for the warranty to be transferred.

Please fill in the appropriate warranty registration card at the back of this owner's manual and mail it to:

Beneteau USA Inc.  
(Customer Service Dept.)  
1313 Highway 76 West  
Marion, SC 29571  
Tel (843)-629-5300  
Fax (843)-629-5329

#### **IV) HULL IDENTIFICATION NUMBERS**

The hull identification or "BEY" number is a unique number given to your Beneteau alone. This number begins with "BEY" which has been assigned to Beneteau by the USCG followed by an alpha-numeric code which details the model, serial no., month of construction, year of construction and model year.

**Please clearly identify your boat using your model and "BEY" number during any correspondence with Beneteau.**

Your boat identification number appears in two places:

The main hull identification number is located on the aft starboard side, near the transom, stamped into the hull, approximately 3 inches below the toerail.

The second hull identification number is in a hidden area for anti-theft purposes.

#### **V) DEALER'S RESPONSIBILITIES**

Your Beneteau Dealer is an independent sales agency and they are a part of a worldwide distribution network, with dealers in 28 countries. A Beneteau Dealer, has certain obligations to you as the customer and to Beneteau as an authorized sales agency. A Dealer's responsibility does not end with the sale of your boat. Your Dealer is responsible for the following:

- Delivering your new Beneteau to you complete, as ordered in your purchase agreement.
- Preparation of your boat for commissioning by their personnel, or another boat yard contracted by them to accomplish the correct commissioning procedures.
- Checking of all systems on the boat for fit, proper function and to familiarize you with the usage of each system.
- Sea trial of your new Beneteau with you as a final verification that all systems are in good order.
- Providing customer support and spare parts after you take delivery and any warranty service under the terms of the limited warranty. All warranty questions/claims or processing should be directed through your dealer.

## **VI) OWNER'S/OPERATOR'S RESPONSIBILITIES**

### **STATE REGISTRATION OR FEDERAL DOCUMENTATION**

For State Registration please consult your Dealer or the State offices in charge of boating, who can provide the correct governmental department handling registration in your state. Your Dealer also should be able to advise you on the possibility of Federal Documentation with the US Coast Guard.

### **SAFETY AND MAINTENANCE**

For maximum enjoyment of your Beneteau, due respect should be given to proper safety and maintenance procedures.

Be sure that your boat is operated according to the U.S. Coast Guard Regulations as outlined in the "Federal Requirements for Recreational Boats". Please familiarize yourself with all operating requirements.

Prepare yourself for any situation before going out on the water. Follow the instructions provided in the sections of this owner's manual, the individual supplier instruction manuals, and all applicable U.S. Coast Guard and other regulations. If you are not an experienced sailor, you should complete an accredited sailing course.

Before leaving the dock, be sure that all your equipment is in working order, that you are aware of the weather conditions, and someone ashore is familiar with your destination or sailing activities.

### **MANDATORY COAST GUARD SAFETY EQUIPMENT**

Many safety items are required for compliance with the U.S. Coast Guard regulations. Note that these regulations are subject to change. It is the owner's responsibility to be aware of current regulations as outlined in the "Federal Requirements for Recreational Boats". For your convenience a copy is included with your yacht's documentation, and additional copies may be obtained by calling the U.S. Coast Guard Boating Info line at (800) 368-5647.

Good safety equipment should be a priority of every sailor for the protection and comfort of passengers. Passengers aboard should be made familiar with the safety equipment and operation of the boat in the event of an emergency.

Depending on the length, passenger capacity, and operating conditions, your boat must be equipped according to the current USCG requirements. Be sure that you operate your boat with the necessary number of life preservers, fire extinguishers, signaling devices, distress signals, navigation lights as referred to in the "Federal Requirements for Recreational Boats."



## RECOMMENDED SAFETY EQUIPMENT

Preparation is the key to safety on the water.

Your new Beneteau has been fitted with the following equipment:

- Compass - be sure that it is properly calibrated to give the correct magnetic reading.
- A large capacity bilge pump.

**We recommend that you fully outfit your Beneteau with safety equipment that can be obtained through your dealer or marine supply outlets. These items should include but not be limited to:**

- Up to date nautical charts covering your intended cruising area.
- Boat hook.
- Large waterproof flashlight with spare batteries.
- Fenders.
- Docking lines - a good rule of thumb to follow dictates that your bow, stern, and spring line be equal to the length of the boat.
- Life jackets, anchor, anchor chain and line, throwing line, flares, soft wooden plugs for thru-hulls, life ring, fire extinguisher, and foghorn.
- Electronics - Depth Sounder, Log Speedometer, and VHF Radio.

## SAFETY COURSES

It is recommended that owners and operators gain knowledge and experience in boat safety skills such as:

- (a) Navigation
- (b) Seamanship and boat handling
- (c) Rules of the road, international and inland waterway
- (d) Weather prediction
- (e) Safety at sea
- (f) Survival in bad weather
- (g) Respect for others on the water
- (h) First aid
- (i) Radio communication
- (j) Distress signals
- (k) Pollution controls

To find out where one can attend these courses in your area, please call your dealer or "The Boaters Educational Course Line" at (800) 336-2628.

## ANCHORING

Various sea and bottom conditions require different anchoring systems. Your dealer can help in choosing rode size and length, anchor chains, and working and storm anchors most appropriate for your boat and location.

In general, a minimum of two anchors should be carried at all times and enough anchor rode and chain necessary for the depth of water to be navigated during storm conditions.

Certain anchors are useful for a variety of bottom conditions. Study the charts of the area to be navigated for information concerning bottom conditions and water depth.

The greatest hazard with a sound permanent mooring is chafe, which can occur to the rode at the bow chocks. This is the single most common site of failure. Care is advised in the selection and protection of the rode pennant with appropriate chafing gear. Careful and regular inspection of moored boats on a regular basis is necessary to ensure the boat's safety.

## ADDITIONAL SAFETY EQUIPMENT

A number of additional safety items are worthy of your consideration. These range from safety harnesses to emergency beacons, life rafts, and survival suits. Their use depends upon the intended use of the yacht. We suggest you investigate the necessity of these items through discussion with your dealer or local chandler.

## MEDICAL KIT

Every yacht should carry a first aid manual, and a medical kit tailored to the specific needs of the owner. Any ship's store should carry a standard type medical kit. Items in the kit should include but not be limited to the following:

- Aspirin
- Adhesive strips and tape
- Antiseptic wipes
- Gauze bandages
- Sunscreen first aid/burn cream
- Sterile pads
- Ace bandages & splints
- Motion sickness pills
- Ammonia inhalants
- Antiseptic germicide ointment
- Zinc oxide ointment
- Insect/bee sting relief ointment/spray
- Cold packs for sprains
- Scissors & tweezers

## TOOL KIT

A basic kit should consist of:

- Wrenches - adjustable, Metric and SAE open end, box, socket
- Hammers - large and small
- Knife - with marlinespike
- Screwdrivers - large and small, standard and Phillips
- Pliers - regular, cutting and needle nose, vise grips
- Wire cutter - capable of cutting standing rigging
- Hacksaw - with spare blades

## SPARE PARTS

A basic kit should consist of the following:

- Standing and Running Rigging: Turnbuckles, monel seizing wire, clevis and cotter pins, shackles, blocks, extra line, rigging tape, duct tape.
- Fasteners: Assortment of stainless steel screws, nuts, bolts, and washers
- Hose clamps.
- Electrical: Electrical tape, wire, crimps on lugs, spare navigation light bulbs.
- Lubricating supplies: WD-40 and silicone grease.
- Engine: Check engine manual for spare parts, engine oil and transmission fluid recommendations.
- Sails: Sail repair kit and sail slides.

## VII) SAFE OPERATION AND WARNING LABELS

Ensure that the boat operator is not under the influence of drugs and/or alcohol.

Do not venture out in weather or sea conditions beyond the skill or experience of the operator.

There are "Warning" and "Caution" statements affixed to your Beneteau. These are detailed below with location:

### FUEL WARNING LABEL

- Affixed to the fuel tank.

Beneteau Part #111358



### SHORE-POWER LABEL

- At the 110V distribution panel.

Beneteau Part #111359



## PROPANE LABELS

- At the propane stove affixed to the bulkhead in the galley

Beneteau Part #111353

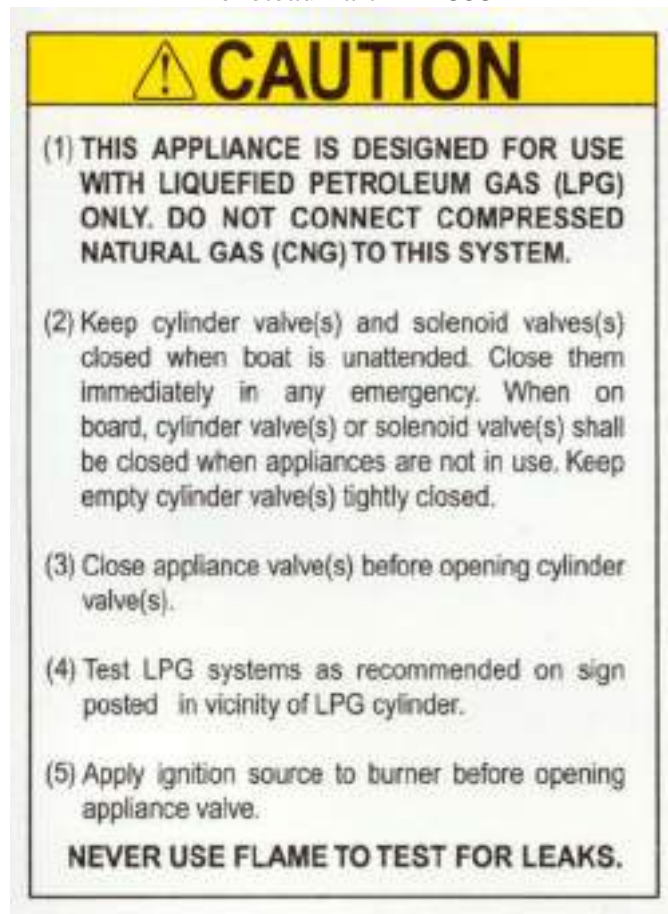

Beneteau Part #111357



- In the propane locker affixed under the propane locker lid

Beneteau Part #015903

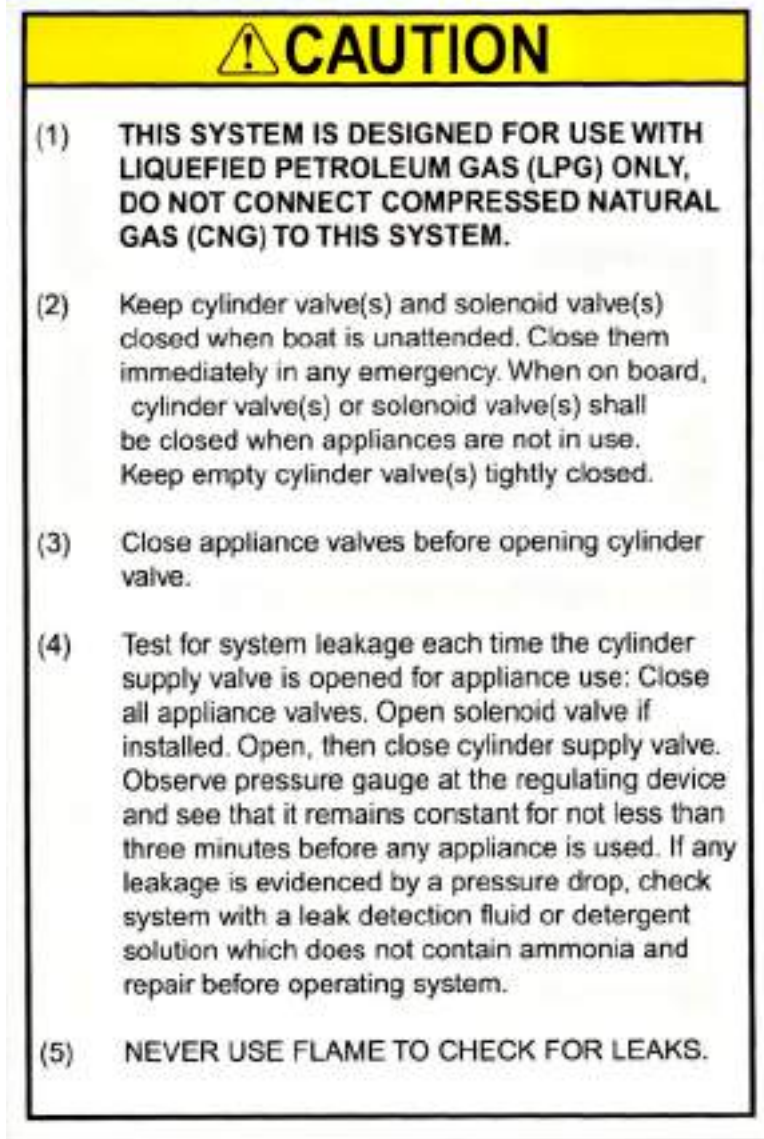

- On or next to the LP Gas Line

Beneteau Part #111361



## SWIM LADDER WARNING LABEL

- Located on the transom

Beneteau Part # 111354



## HIGH VOLTAGE WARNING LABEL

- Located beside the 110v electric panel.

Beneteau Part #111365



## TRANSOM DOOR WARNING LABEL

- Located on or next to the helmsman's seat. (Not applicable on all models)

Beneteau Part #111362



### STANDARD BATTERY SWITCH LABEL

- Located at the standard battery switches.  
Beneteau Part #111363



### OPTIONAL INVERTER BATTERY SWITCH LABEL

- Located at the battery switches  
Beneteau Part #112624 (Not applicable on all models)

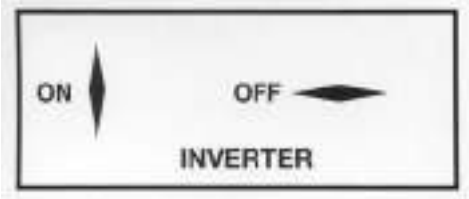

### SLING LOCATION ARROWS LABEL

- Located at or near the hull to deck joint  
Beneteau Part #111364

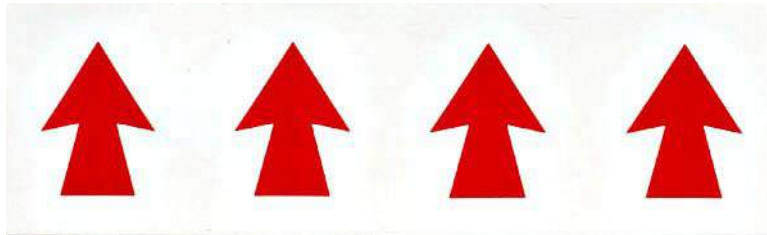

### ANTI FREEZE CAUTION TAG

- Tied to the breaker for the water  
Beneteau Part #111046

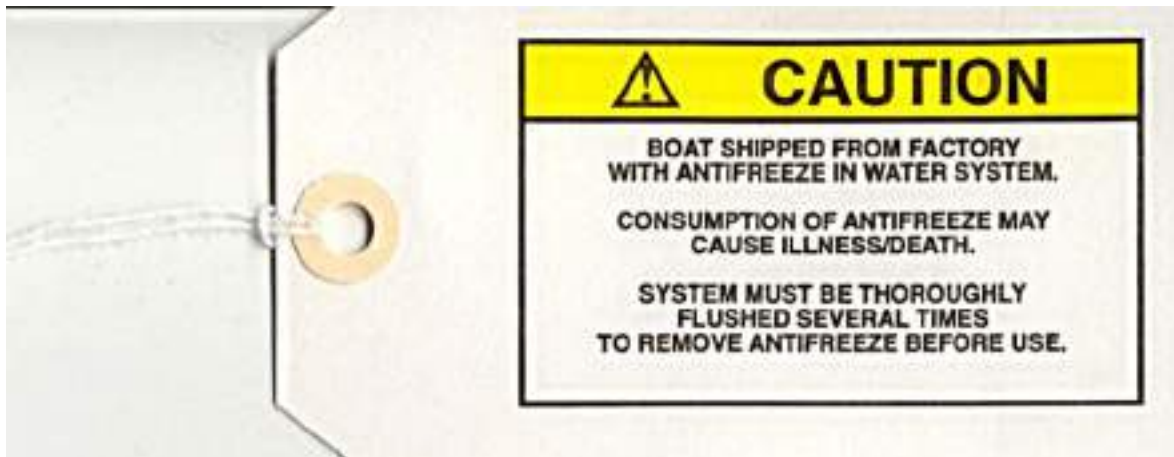



## VIII) FEDERAL/STATE REGULATIONS

### DISCHARGE OF OIL

- Located: under the sail locker lid.

Beneteau Part #111352

## **DISCHARGE OF OIL PROHIBITED**

The Federal Water Pollution Control Act prohibits the discharge of oil or oily waste into or upon the navigable waters of the United States or waters of the contiguous zone if such discharge causes a film or sheen upon, or discoloration of, the surface of the water, or causes a sludge or emulsion beneath the surface of the water. Violators are subject to a penalty of \$5,000.

**BENETEAU**

## SOLID WASTE DISPOSAL

- Located under the sail locker lid.

Beneteau Part #111356

It is illegal for any vessel to dump plastic trash **anywhere** in the ocean or navigable waters of the United States. Annex V of the MARPOL TREATY is an International Law for a cleaner, safer marine environment. Violation of these requirements may result in civil penalty up to \$25,000 fine and imprisonment.

3 Miles from Shore	3-12 Miles from Shore	12-25 Miles from Shore	Outside 25 Miles
U.S. Lakes, Rivers, Bays and Sounds <b>ILLEGAL TO DUMP</b> Plastic & Garbage, Paper, Rags, Glass, Food, Metal, Crockery, Dunnage.	<b>ILLEGAL TO DUMP</b> Plastic, Dunnage, lining & packing materials that float, also if not ground to less than one inch; Paper, Rags, Glass, Crockery, Metal, Food.	<b>ILLEGAL TO DUMP</b> Plastic, Dunnage, lining & packing materials that float.	<b>ILLEGAL TO DUMP</b> Plastic

State and local regulations may further restrict the disposal of garbage.

## MARINE SANITATION

Your Beneteau is equipped with an USCG approved marine head and holding tank.

**By law you must use a holding tank in all U.S. waters, Check with local authorities for regional laws governing your area before selecting the overboard discharge option.**

## **ACCIDENT REPORTING**

Knowledge of accident reporting requirements. Please refer to the following list for a copy of the U.S. Coast Guard Boating Accident form. For further information on where to obtain more forms, please call the U.S. Coast Guard Boating Safety Hotline at (800) 368-5647

NATIONAL VESSEL DOCUMENTATION CENTER  
2039 STONEWALL JACKSON DR.  
FALLING WATERS, WV 25419  
TOLL FREE: 1-800-799-8362  
PHONE: (304) 271-2400  
FAX: (304) 271-2405

## **RENDERING ASSISTANCE**

United States Code, Title 46:

"The owner or operator of a vessel is required by law to render assistance to any individual or vessel in distress, so long as his vessel is not endangered in the process."

## IX) COMMISSIONING

### COMMISSIONING PROCEDURES

The first commissioning of a yacht is essentially the start of its life, and the importance of proper commissioning procedures at this time cannot be overstated. The first commissioning procedure must be performed by an authorized Beneteau dealer or those authorized by them. The dealer will also have a commissioning checklist to be signed by the owner and a dealer representative at the time of the first commissioning. The owner also needs to concern himself with items such as safety equipment, which is considered to be his responsibility. See the Owner's Operator's Responsibilities section for details.

Lists of the pre-launch and post-launch checks employed during commissioning are provided in this section for those owners interested in understanding the commissioning procedure, as well as for future use in any recommissionings that may be required after periods of wet or dry storage. The lists are of a general nature and do not attempt to provide step-by-step instructions.

**The following is a list of minimum commissioning duties. Additional operations may be required dependent upon the model & equipment**

#### PRIOR TO LAUNCH

- \_\_\_\_\_ All accessories & options supplied per shipping list and boat order
- \_\_\_\_\_ Check hull and repair any shipping damage - aft end of keel, rudder, etc.
- \_\_\_\_\_ Prep bottom and apply bottom paint if needed.
- \_\_\_\_\_ Thru hulls inspected and closed.
- \_\_\_\_\_ Clean hull thoroughly.
- \_\_\_\_\_ Check clamps on all thru hulls below waterline.
- \_\_\_\_\_ Wax hull topsides.
- \_\_\_\_\_ Dock lines and fenders aboard.
- \_\_\_\_\_ Check tightness of nuts on prop shaft and zinc. (Folding props require additional steps).
- \_\_\_\_\_ Check steering system (rudder moving freely stop to stop and does not touch hull?).  
(Hydraulic steering requires all fittings be checked and the system is bled)
- \_\_\_\_\_ Zincs installed.
- \_\_\_\_\_ Thru hulls unobstructed and speed/log impeller in place (if applicable).
- \_\_\_\_\_ Fuel valve turned ON.
- \_\_\_\_\_ Check keel bolts for tightness.

## OPERATIONS AFTER LAUNCH

- \_\_\_\_\_ No water leaks, stuffing box, shaft log, strut, rudder post.
- \_\_\_\_\_ No leaks at thru hulls; all hose clamps secure with seacocks open.
- \_\_\_\_\_ Fill water tanks, no leaks at fill pipes, overflows or connections.
- \_\_\_\_\_ Fill fuel tank.
- \_\_\_\_\_ Batteries secured, connected, filled and charged. (**NOTE: Beneteau ships batteries dry**)
- \_\_\_\_\_ Check all cabin lights.
- \_\_\_\_\_ Check all navigation lights.
- \_\_\_\_\_ Water pressure system - air bled, no leaks at connections.
- \_\_\_\_\_ Check electric sump pumps and bilge pump.
- \_\_\_\_\_ Check manual bilge pump
- \_\_\_\_\_ Check emergency tiller fit.
- \_\_\_\_\_ 110V shore power polarity ok and breakers on
- \_\_\_\_\_ Battery charger ok.
- \_\_\_\_\_ Hot water heater works-must be filled before turning on.
- \_\_\_\_\_ Check head(s) operation and holding tank(s) for leaks.
- \_\_\_\_\_ Test wash down pumps, refrigeration, heaters, etc.
- \_\_\_\_\_ Test stove and LPG tank for leaks and proper operation
- \_\_\_\_\_ **DO NOT TEST FOR LEAKS WITH AN OPEN FLAME, WIPE EACH JOINT WITH A SOAPY SOLUTION AND LOOK FOR BUBBLES**

## ENGINE START-UP

- \_\_\_\_\_ Check transmission for proper fluid and proper level.
- \_\_\_\_\_ Check crankcase dipstick for proper fluid and proper level.
- \_\_\_\_\_ Check shift and throttle cables for proper adjustment and secure end fittings.
- \_\_\_\_\_ Engine alarms work when key is on.
- \_\_\_\_\_ Open engine water intake.
- \_\_\_\_\_ Start engine, check gauges and water flow at exhaust is normal.
- \_\_\_\_\_ Check water level in heat exchanger and expansion tank.
- \_\_\_\_\_ Check belts and mounts.
- \_\_\_\_\_ Run engine at operating temperature. Note temperature \_\_\_\_\_degrees.
- \_\_\_\_\_ No engine or fuel line leaks-no chafe problems with wires.
- \_\_\_\_\_ Forward and reverse gears operate.
- \_\_\_\_\_ After warm-up, shut engine down, check oil, and fluid levels again.
- \_\_\_\_\_ Alignment to under .003 - coupling bolts tightened.
- \_\_\_\_\_ Idle set correctly , engine won't stall when put in gear. Idle set at \_\_\_\_\_ RPM.
- \_\_\_\_\_ Allow engine to run for at least (1) hour.
- \_\_\_\_\_ No leaks at the shaft seal.
- \_\_\_\_\_ Shift and throttle operate smoothly with engine running.
- \_\_\_\_\_ No leaks at keel bolts after engine run.
- \_\_\_\_\_ Test run boat, check all operations of shifting, controls etc.
- \_\_\_\_\_ Maximum RPM in gear \_\_\_\_\_.

## **PRIOR TO STEPPING MAST**

- \_\_\_\_\_ Clean or wax spar.
- \_\_\_\_\_ Mast sheaves free running.
- \_\_\_\_\_ Run halyards if necessary– Make sure you have clean hands on clean ground.
- \_\_\_\_\_ Attach and secure all stays and shrouds.
- \_\_\_\_\_ Attach and secure spreaders to mast and upper shrouds.
- \_\_\_\_\_ Check boom gooseneck fitting.
- \_\_\_\_\_ Install mast boot on spar if applicable.
- \_\_\_\_\_ Check all mast lights.
- \_\_\_\_\_ Attach and secure boom topping lift.
- \_\_\_\_\_ Check running lights and electrical connections.
- \_\_\_\_\_ Protect against chafe on spreader ends and any fitting.
- \_\_\_\_\_ Check sail track for burrs.
- \_\_\_\_\_ Turnbuckles attached.
- \_\_\_\_\_ Re-check all pins, cotters, and Loctite any shackles.
- \_\_\_\_\_ Check with salesman and work order for additional mast gear.
- \_\_\_\_\_ Furling system built and connected to mast

## **AFTER STEPPING MAST**

- \_\_\_\_\_ Protect spar from scratching on mast collar on keel stepped masts.
- \_\_\_\_\_ Turnbuckles lubricated.
- \_\_\_\_\_ Attach standing rigging to chain plates.
- \_\_\_\_\_ Chock mast partner and seal mast boot on keel stepped masts.
- \_\_\_\_\_ All mast wiring connected.
- \_\_\_\_\_ Preliminary tune - spar straight - shrouds proper tension.
- \_\_\_\_\_ Run reefing lines and halyards.
- \_\_\_\_\_ All cotter pins in place on turnbuckles and opened.
- \_\_\_\_\_ Run main sheets and attach topping lift.
- \_\_\_\_\_ Tape chain plates and cotter pins to prevent chafe.
- \_\_\_\_\_ Check and double-check all turnbuckles, cotter and clevis pins.

## **PRIOR TO DELIVERY**

- \_\_\_\_\_ Hose test all ports, deck hardware, chain plates, and stanchion posts for leaks.
- \_\_\_\_\_ Tighten lifelines and tape split rings.
- \_\_\_\_\_ All doors, drawers, floorboards, hatches, and cabinets operate freely - fit if necessary.
- \_\_\_\_\_ Clean thoroughly: sinks, bulkheads and counter tops, all lockers and drawers, bilge, cushions, deck and cockpit lockers.
- \_\_\_\_\_ Dry the bilge completely.
- \_\_\_\_\_ Clean and oil exterior teak if needed.
- \_\_\_\_\_ Clean cabin sole, deck area and ports.
- \_\_\_\_\_ All Coast Guard and safety gear aboard.
- \_\_\_\_\_ Sails bent on, ALL HEADSAILS (AND MAINSAIL) FIT FURLING. Operate freely.
- \_\_\_\_\_ All electronics and optional gear tested and working.

## **DELIVERY TO OWNER**

- \_\_\_\_\_ Walk through the boat with manuals and owner, showing operation of all components.
- \_\_\_\_\_ Test sail boat with owner showing all operations.
- \_\_\_\_\_ Fill out warranty certificates.

## X) SPECIFICATIONS OF THE BOAT

Type ..... BENETEAU 323  
Name of Builder ..... BENETEAU USA INC.  
Design Category ..... B  
No. of acknowledged body ..... CE 0607

### **CE CERTIFICATION**

Your Beneteau has been manufactured in the United States and has been certified by ICNN to be in compliance with the relevant parts of the Recreational Craft Directive 94/25/EC from the European Parliament. The CE mark means your boat meets or exceeds all current International Organization for Standardization (ISO) standards and directives in effect at the time of manufacture. The builders plate located in the cockpit of your boat, gives information pertinent to this certification, such as; model, design category with corresponding max. number of persons recommended, and max. load weight. Following are the design categories established by the Recreational Craft Directive. This is a guideline only, the safety of those on board your boat are only measurable by the experience and skill of the captain and crew, together with proper preparation and appropriate safety equipment for the given conditions, in addition to a well maintained boat. This certification only applies to factory installed equipment and does not cover equipment installed by the dealer or owner. In the case of European travel such equipment installed after manufacture may need to be certified separately.

### DESIGN CATEGORIES

- Category A: OCEAN – Designed for extended voyages where conditions may exceed wind force 8 (Beaufort scale) and significant wave heights of 4 m and above, and vessels largely self sufficient
- Category B: OFFSHORE – Designed for offshore voyages where conditions up to, and including, wind force 8 and significant wave heights up to, and including, 4 m may be experienced.
- Category C: INSHORE – Designed for voyages in coastal waters, large bays, estuaries, lakes and rivers where conditions up to, and including, wind force 6 and significant wave heights up to, and including, 2 m may be experienced.
- Category D: SHELTERED WATERS – Designed for voyages on small lakes, rivers, and canals where conditions up to, and including, wind force 4 and significant wave heights up to, and including, 0.5 m may be experienced.

Category	Height of the Waves (ft)	Wind Force (Beaufort)
A	> 4 m (13.0 ft)	> 8
B	< 4 m (13.0 ft)	≤ 8
C	< 2 m (6.5 ft)	≤ 6
D	< .5 m (1.6 ft)	≤ 4

Maximum recommended number of persons on board by design category:

Category	Maximum Number of Persons
A	
B	6
C	8
D	10

The C.E. Certified equipment includes: The fuel tanks, parts of the steering system, parts of the gas system and the hatches and portholes.

For additional information concerning the standard equipment, please refer to the manuals enclosed with the boat.



Length Over All	10.00 m	32.81 ft
Hull Length	9.72 m	31.89 ft
Length Waterline	8.89 m	29.17 ft
Hull Beam	3.27 m	10.73 ft
Draft:	Centerboard	
(from waterline)	Shoal	1.45 m 4.76 ft
	Deep	1.80m 5.91 ft
Clearance Height (from waterline)	14.85 m	48.72 ft

Maximum Authorized Engine Power :	25 kW	33 hp
-----------------------------------	-------	-------

Fuel Capacity	65 L (17.2 US gal)
Fresh Water Capacity	182 L (48.1 US gal)
Waste Tank Capacity	50 L (13.2 US gal)
Battery Capacity	75A engine 75A house

## WEIGHT ESTIMATION

SAILING CATEGORIES	A	B	C	D
	Kg (lbs)	Kg (lbs)	Kg (lbs)	Kg (lbs)
<b>Light Displacement :</b>		<b>4230 (9326)</b>	<b>4230 (9326)</b>	<b>4230 (9326)</b>
Includes:				
Light Boat + Safety Equipment + Sails				
Life Raft :		55 (121)	55 (121)	55 (121)
Crew :		450 (992)	600 (1323)	750 (1654)
Water :		160 (353)	160 (353)	160 (353)
Fuel :		60 (132)	60 (132)	60 (132)
Personal Equipment :		270 (595)	160 (353)	50 (110)
<b>Optional Equipment</b>				
Air Conditioning		80 (176)	80 (176)	80 (176)
Holding Tank :		60 (132)	60 (132)	60 (132)
Auto Pilot Gear :		10 (22)	10 (22)	10 (22)
Mech. Refrigeration		20 (44)	20 (44)	20 (44)
Furling Mast		20 (44)	20 (44)	20 (44)
Spinnaker Gear :		10 (22)	10 (22)	10 (22)
Microwave Oven :		5 (11)	5 (11)	5 (11)
Roof Sprayhood :		10 (22)	10 (22)	10 (22)
Bimini :		10 (22)	10 (22)	10 (22)
<b>SUB TOTAL (Optional Equipment)</b>		<b>225 (496)</b>	<b>225 (496)</b>	<b>225 (496)</b>
<b>Margin for Other Equipment</b>		<b>80 (176)</b>	<b>40 (88)</b>	<b>0 (0)</b>

<b>MAXIMUM LOAD DISPLACEMENT Kg (Lbs.)</b>	<b>5530 (12,192)</b>	<b>5530 (12,192)</b>	<b>5530 (12,192)</b>
--	----------------------	----------------------	----------------------

<b>MAXIMUM LOAD Kg (Lbs.)</b>	<b>1300 (2866)</b>	<b>1300 (2866)</b>	<b>1300 (2866)</b>
-----------------------------------	--------------------	--------------------	--------------------

**MAXIMUM LOAD = MAXIMUM LOAD DISPLACEMENT – LIGHT DISPLACEMENT**

ANY OVERLOADING CARRIES A RISK OF FLOODING OR LOSS OF STABILITY

**XI) INTERIOR LAYOUT**

**LAYOUT**

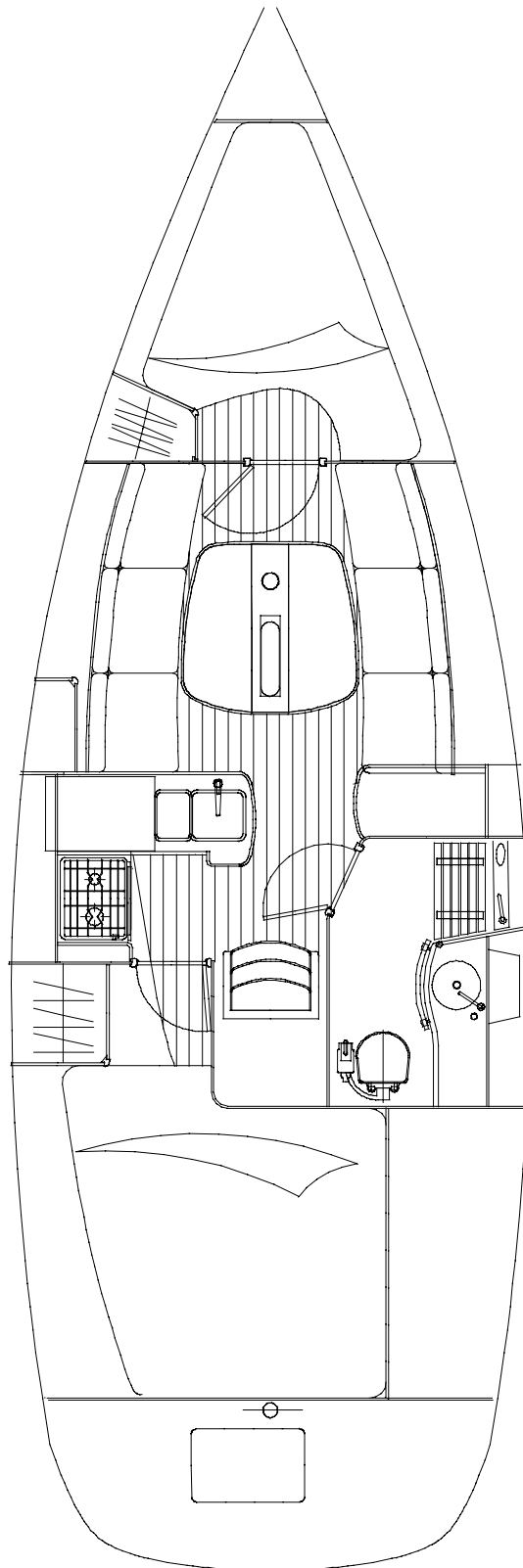

# EXIT IN CASE OF FIRE



= Emergency Exit



= Recommended Fire Extinguisher Location



= Engine Compartment Fire Extinguisher Port

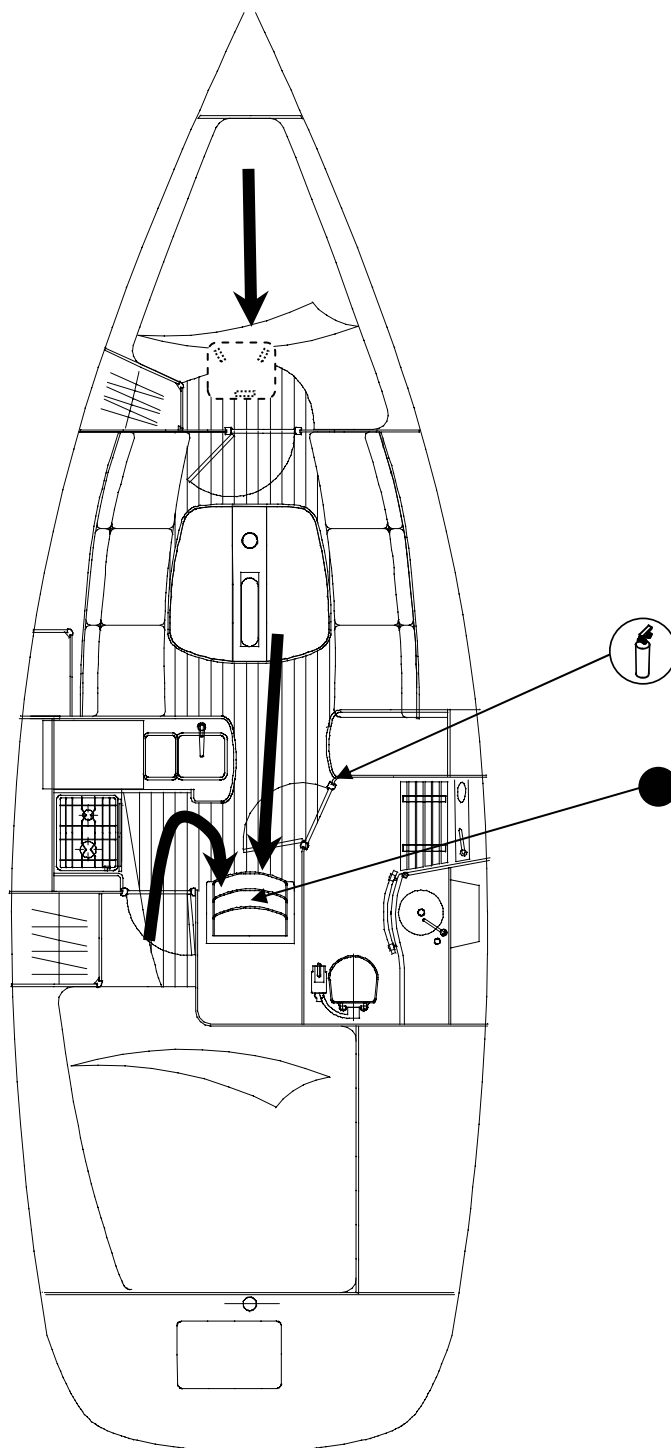

## XII) DECK

- Jack lines can be fastened either to the mooring cleats, or to pad eyes on deck.

**The Beneteau 323 is fitted with a foldaway swimming ladder. The swimming ladder should be in its folded/upright position as soon as you are on board.**

**The transom area is not considered part of the working deck and should not be used while underway  
See diagram below**

**Make sure that the hatches and portholes are closed before you put out to sea.**

**In case of rough sea, close the boat with the sliding hatch and weatherboards so that no water may come into the boat.**

**Check that nothing blocks the cockpit drain holes; these holes should never be sealed.**

- 1 Recommended location of the life-raft
- 2 Fwd water tank deck fill
- 3 Waste tank pump out deck plate
- 4 Fuel deck fill
- 5 Swim ladder



Recommended Fire Extinguisher Location



Zones excluded from working deck

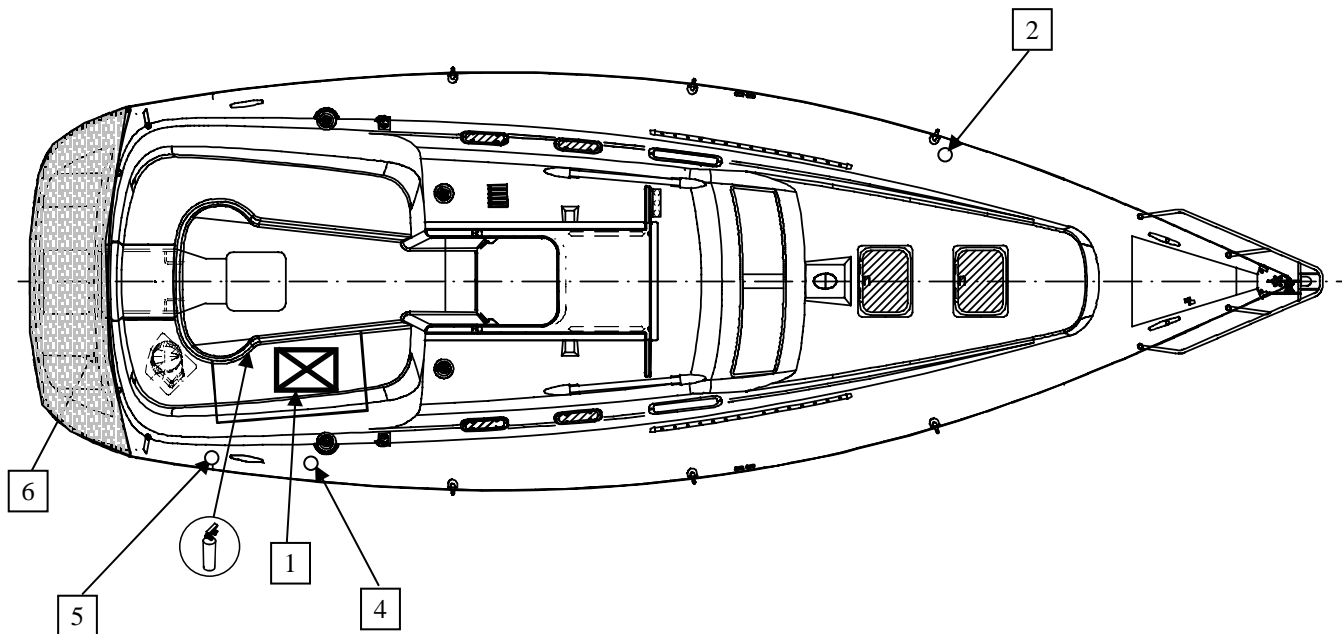

### XIII) SAILS AND RIGGING

#### SPECIFICATIONS OF THE SAILS:

SAIL	AREA	
	Roller furling main	Classic main
Total	48.1 m <sup>2</sup>	51.7 m <sup>2</sup>
Mainsail	23.5 m <sup>2</sup>	27.1 m <sup>2</sup>
Genoa (116%)	24.6 m <sup>2</sup>	24.6 m <sup>2</sup>

Roller furling mast			Classic mast		
I	13.006	m	I	13.006	m
J	3.372	m	J	3.372	m
P	11.71	m	P	11.86	m
E	4.015	m	E	4.015	m

#### Specifications of the Standing Rigging:

V: VERTICAL - D: DIAGONAL

REF	CABLE	Dia. In.
1	VID2	1/4
2	D1 AFT (Aft Lower Shroud )	1/4
3	Forestay	1/4
4	Double Backstay	3/16

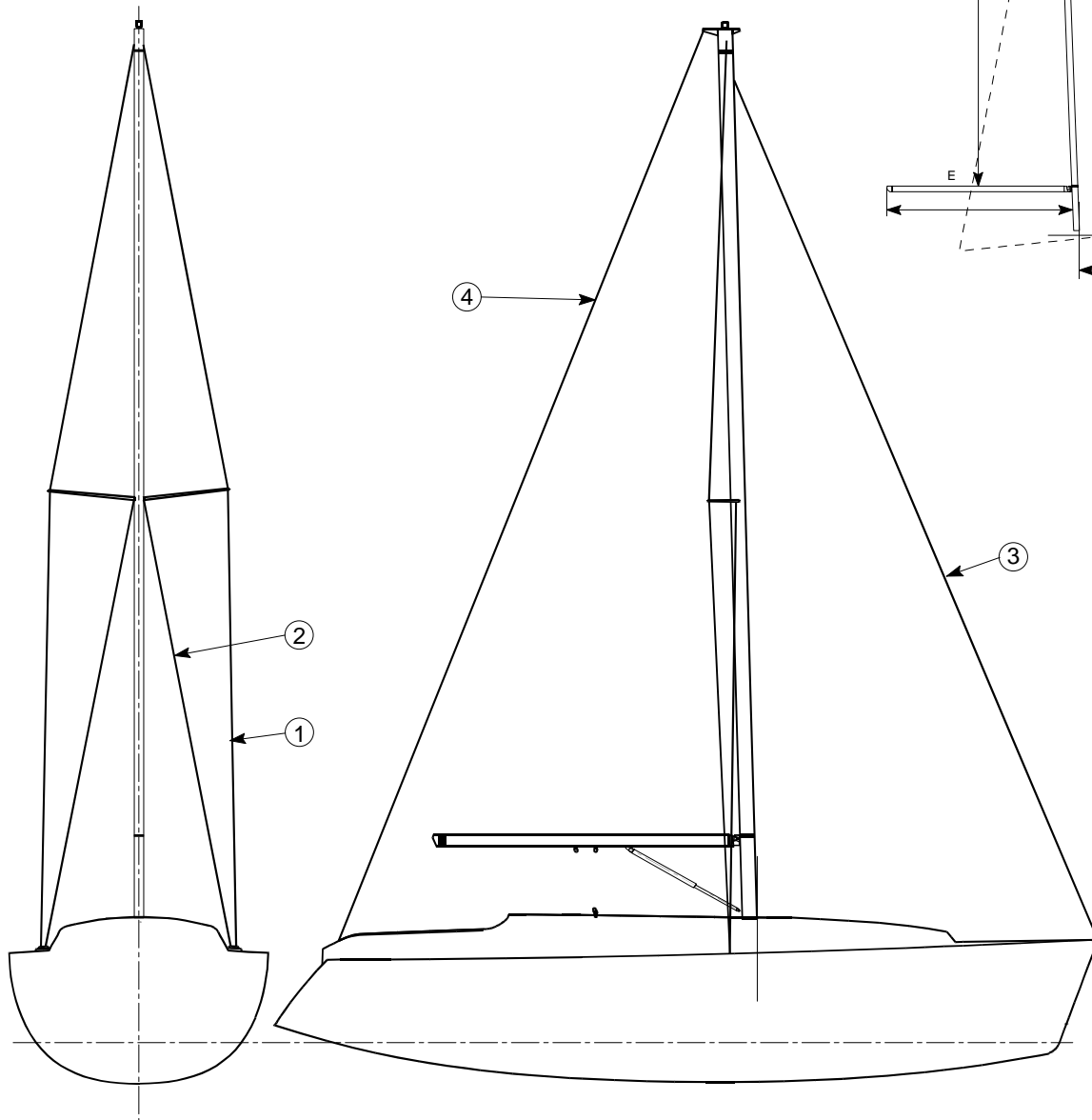
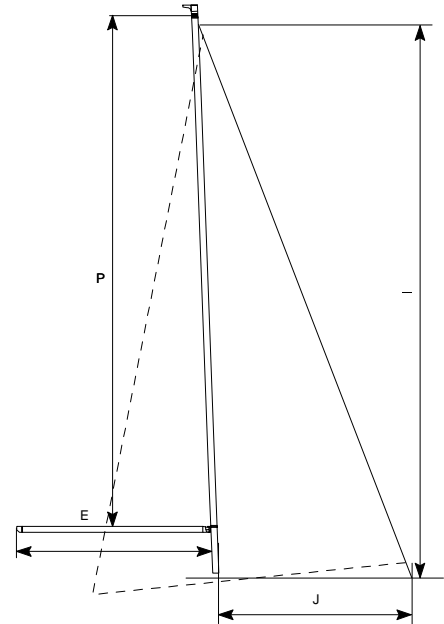

# STANDING RIGGING

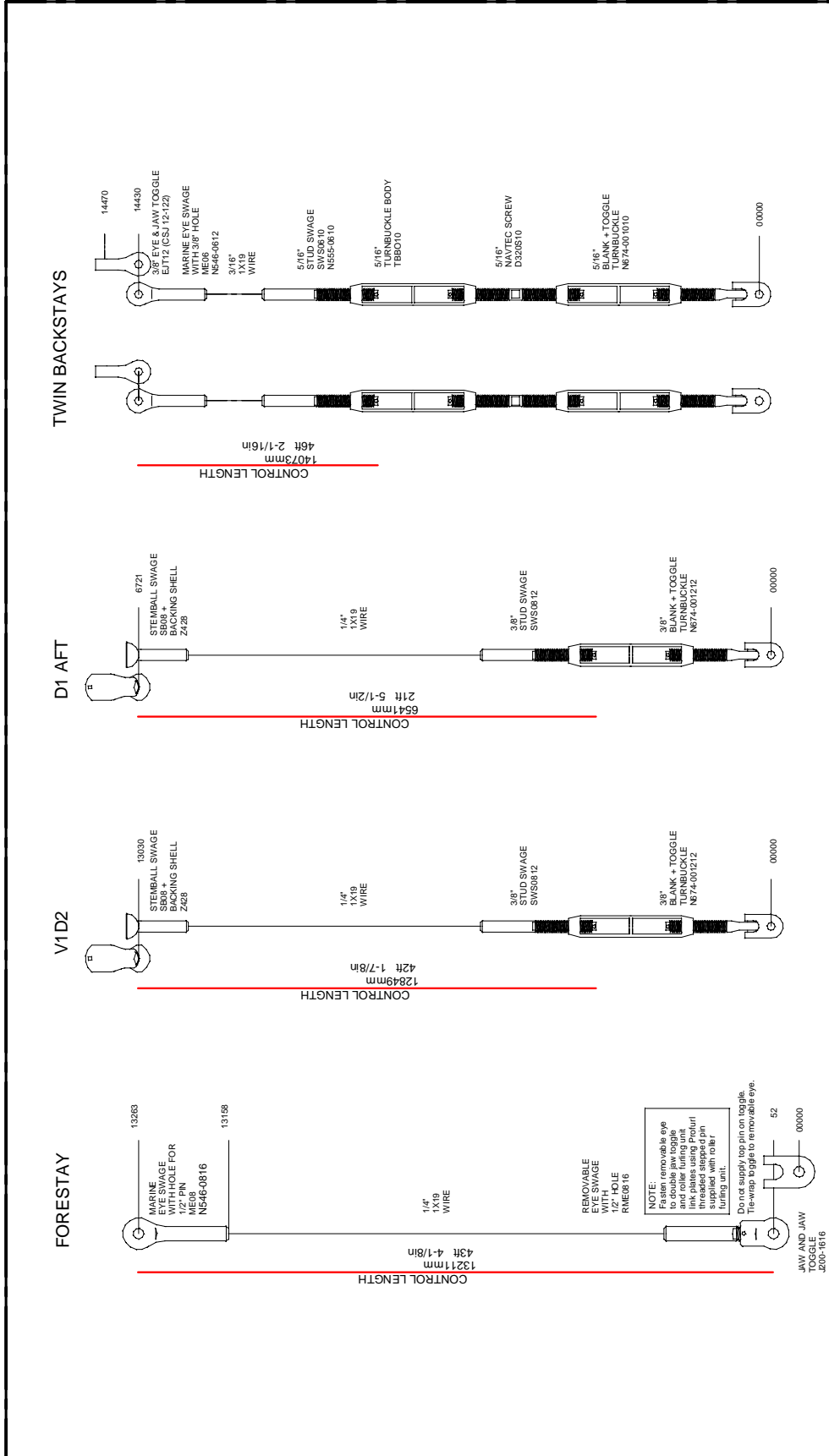

Material :	Dimension in mm :	Gen.Tol.:	Visa :
	Scale:		
01	CAUTION CAO DRAWING Add double turnbuckle + masthead toggles to backstay.		Design Date : 09/01/03 By : BDB
	BDB 12/03/03		Approved Date :
R	DESCRIPTION	By DATE	Weight :
BENETEAU USA INC. 1313 HIGHWAY 76 WEST PO DRAWER 1218, MARION, SC 29571 Tel. (843) 423-4201 - Fax. (843) 425-4912		N°112727	01
THIS DOCUMENT IS - PROPRIETARY AND REPRODUCTIONS MUST BE AUTHORIZED BY BENETEAU - DRAWN BY BENETEAU - SPECIFIED AND DESIGNED BY PRODUCT MANUFACTURER.			

NOTE:  
ALL MEASUREMENTS TAKEN WITH  
TURNBUCKLES 2/3 OPEN

MAKE	PROFURL
MODEL	B29S - 14M
NUMBER OF EXTRUSIONS	6 X 2M & 1 X 0.655M
FORESTAY DIAMETER	1/4" 1X19 SS CABLE

- PLASTIC MULTI TOP HALYARD WRAP STOP CAP

- HALYARD SWIVEL WITH HALYARD SHACKLE 6mm BOW

- INTEGRAL FEEDER

- NO PRE-FEEDER

- AJUSTABLE TACK SHACKLE ON TURNBUCKLE CYLINDER 6mm BOW SHACKLE

- STAINLESS STEEL DRUM GUARD

- 21.3Mx8mm DACRON LINE (70'x5/16")

- PLASTIC DRUM

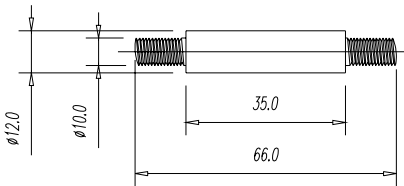

THREADED STEPPED PIN  
ATTACHES REMOVABLE EYE TO THE  
DOUBLE JAW TOGGLE & PROFURL  
LINK PLATES  
DOUBLE JAW TOGGLE SUPPLIED  
WITH FORESTAY

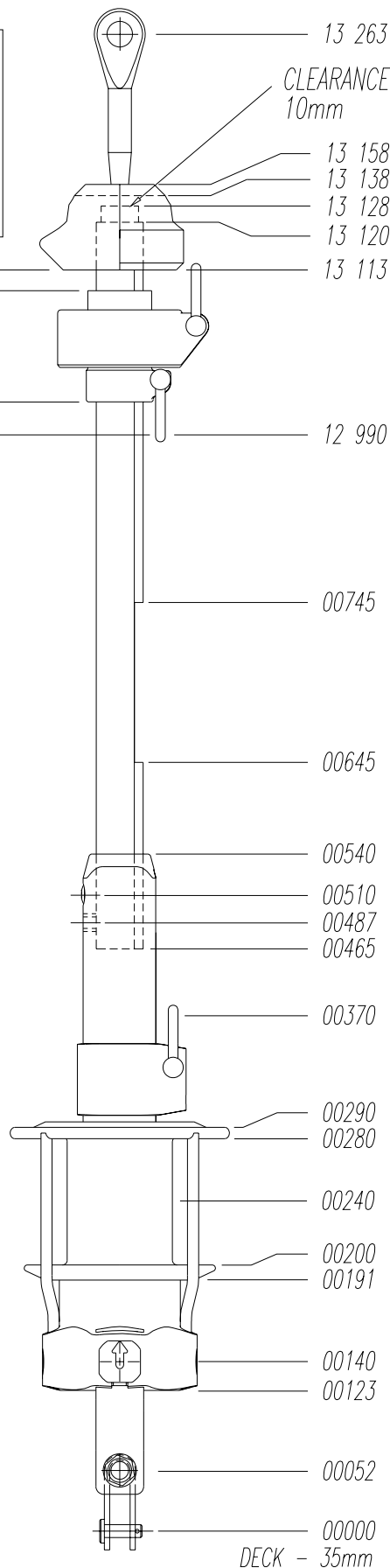

MATERIAL: PROFURL	VIEW	ALSO SHOWN: 112730 EXTRUSION KIT PART NUMBER DRUM KIT 112729
	DESIGN DATE 09/04/2003 BY: VWH	
DIMENSIONS: MILLIMETERS	SCALE: NONE GEN. TOL. NONE	PROFURL BASIC GENOA RF SYSTEM 0323
	DATE 09/06/2003 09/09/2003	
CODE	PROTOTYPE VARIOUS CHANGES	
R	0 1	

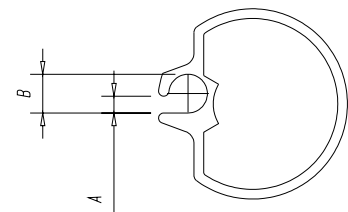

DIMENSION mm	A	B
LUFF GROOVE	2.6	5.8

### Headsail Specification and Technical Worksheet

<b>Model Type:</b>		<b>Beneteau 323</b>					
<b>Sail Type:</b>		Roller Furling Genoa					
<b>"I" Dim:</b>	13006	<b>"J" Dim:</b>	3372	<b>Max Hoist:</b>	12620	<b>Area:</b>	23.75m <sup>2</sup>
<b>Finished Dimensions</b>							
<b>Luff:</b>	12450	<b>Leech:</b>	11780	<b>Foot:</b>	4075	<b>L.P.:</b>	116% /3911
<b>Finish Details</b>							
<b>Material Type:</b>	5.9 Contender			<b>Tack Detail:</b>	Double webbing Loop		
<b>Head Detail:</b>	Double Webbing Loop			<b>Clew Detail:</b>	40mm external ring with leather		
<b>Leech Cleat:</b>	241 aluminum cleat w/snubbing eyes			<b>Foot Cleat:</b>	2 #1 eyelets at tack		
<b>Foot/Leech:</b>	Single fold, hot-knifed 25mm tabling			<b>U.V. Cover:</b>	U.V. Dacron w/top backside cover		
<b>T.T. Window:</b>	9inch vinyl			<b>Leech/Foot Line:</b>	3mm Polyester		
<b>Foil Tape:</b>	NP #5			<b>Trim stripe:</b>	2 x 3/8" in black		
<b>Bag Type:</b>	Drawstring type "a"			<b>Seam:</b>	V-92 Blue / 2 rows 3-step		
<b>Ditty Bag:</b>	Std. NP Ditty Bag Kit			<b>Furling System:</b>	Ref: Beneteau # 112729		
<b>Drawing Information</b>							
<b>Drawing Name:</b>	B323 RFG	<b>Drawn By:</b>	BP	<b>Date:</b>	11-02	<b>Rev. #</b>	112736 rev0 - 0323 rf genoa.doc
<b>Additional Notes:</b>	Prototype Genoa.						

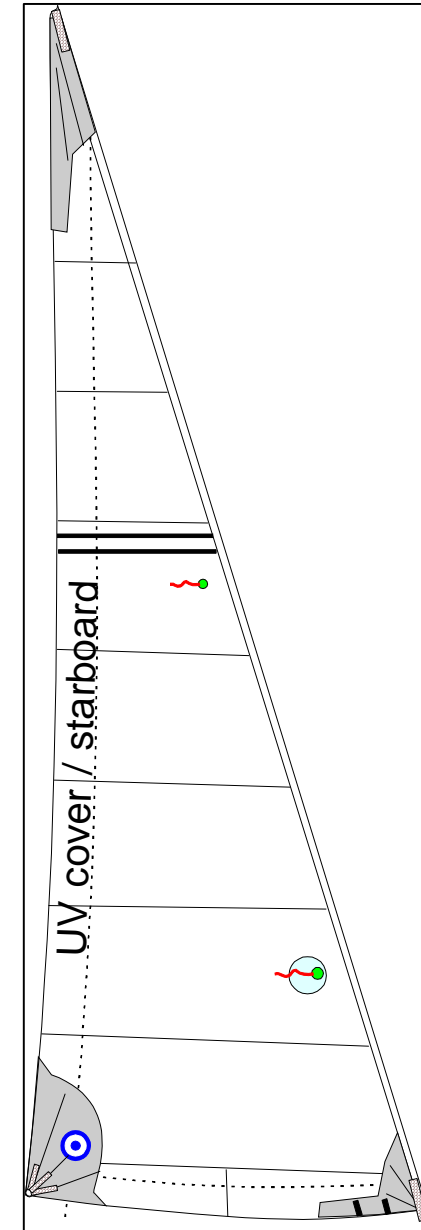
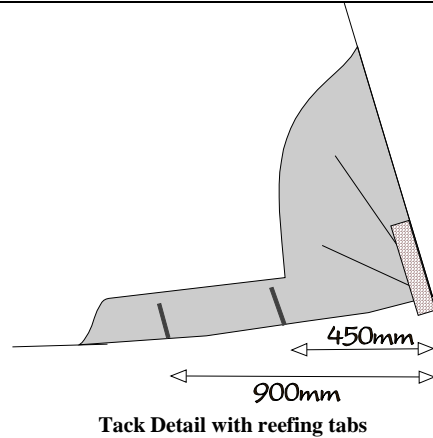



## Mainsail Specification and Technical Worksheet

<b>Model Type:</b>		<b>Beneteau Oceanis 323 USA</b>			
<b>Sail Type:</b>		Roller Furling Mainsail			
<b>"P" Dim:</b>	11710	<b>"E" Dim:</b>	4015	<b>Sailmaker "E"</b>	<b>Area:</b> 22.00sqmt
<b>Finished Dimensions</b>					
<b>Luff:</b>	11582	<b>Leech:</b>	11814	<b>Foot:</b>	3977
<b>Finish Details</b>					
<b>Material Type:</b>	7.4 Contender		<b>Tack Detail:</b>	Single ply 25mm webbing loop	
<b>Head Detail:</b>	Single ply 25mm webbing loop		<b>Clew Slug/Car:</b>	Z-spar 3259 Clew block	
<b>Clew Detail:</b>	Pg 38 safety clew ring with webbing		<b>Insignia:</b>	Yes, black	
<b>Furling Label</b>	120mm behind UV Cover		<b>Seams:</b>	2 rows of 3-step, Blue V-92	
<b>Draft Stripe:</b>	2x3/8" black		<b>Tell Tale:</b>	Yes, 2 at leech	
<b>Leech Cleat:</b>	241 Alum cleat with snubbing eyes		<b>Bag Type:</b>	Drawstring type "B"	
<b>Luff Rope</b>	NPS#6 Foil Tape <i>Luff tape ends at the foot/luff intersection.</i>		<b>Cover Material/Colour:</b>	Clew only, both sides: UV Dacron cloth / white	
<b>Mast Section:</b>	Zspar-400E		<b>Boom Section</b>	Zspar - z360	
<b>Tack and Clew Cutback Details:</b>					
<b>A:</b>	50	<b>B:</b>	100	<b>C:</b>	100
<i>Note: These are for design reference only; sail does not have cut back or cut out at foil tape.</i>					
<b>Drawing Information</b>					
<b>Drawn By:</b>	Bob	<b>Date:</b>	Nov-03	<b>Revision #</b>	112735 - R000 - RF Mainsail.doc
<b>Additional Notes:</b>	Finished Dimensions include head and tack webs.				

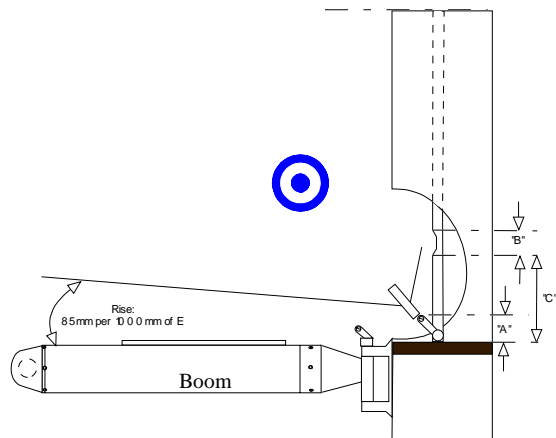

Tack/Clew Detail

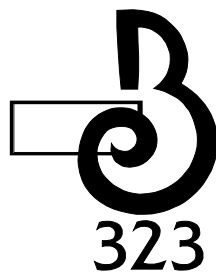

Black Insignia & Furling Label

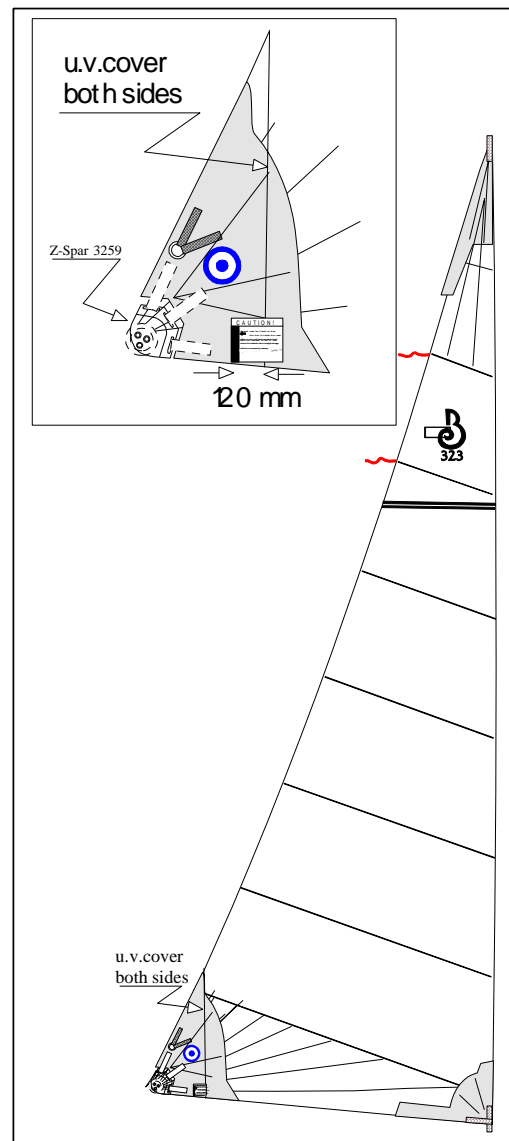

Beneteau Part #: 112735

## Mainsail Specification and Technical Worksheet

<b>Model Type:</b>		<b>Beneteau 323</b>											
<b>Sail Type:</b>		Classic Mainsail											
<b>"P" Dim:</b>	11860	<b>"E" Dim:</b>	4015	<b>Area:</b>	26.61sqmt								
<b>Finished Dimensions</b>													
<b>Luff:</b>	11733	<b>Leech:</b>	12242	<b>Foot:</b>	3967								
<b>Finish Details</b>													
<b>Material Type:</b>	6.9 Contender Dacron		<b>Tack Detail:</b>	40mm SS Ring with leather									
<b>Head Detail:</b>	40mm S.S. ring with leather		<b>Clew Slug/Car:</b>	SLD 151									
<b>Head Slide:</b>	Metal Seldon 661B set just below head ring.		<b>Clew Detail:</b>	40mm SS ring with leather									
<b>Clew Reef 1:</b>	34118 Wichard block on Port Side led through PG 23 ring		<b>Tack Reef 1:</b>	33118 Wichard block on Port Side led through PG 20 ring									
<b>Clew Reef 2:</b>	34118 Wichard block on Port Side led through PG 23 ring		<b>Tack Reef 2:</b>	33118 Wichard block on Port Side led through PG 20 ring									
<b>Ditty Bag:</b>	Packaged with headsail		<b>Logos</b>	2 bullseyes									
<b>Battens:</b>	4 x 25mm flat		<b>Ben. Part#:</b>	112734									
<b>Bat. Lengths:</b>	#1	750	#2	1500	#3	2000	#4	2500	#5	n.a.			
<b>Luff Slides:</b>	16-661A seldon slides		<b>Tell Tale:</b>	4x 1 at each batten									
<b>Leech Cleat:</b>	241 Alum. With snubbing eyes		<b>DraftStripe:</b>	1 in black									
<b>Luff Tape:</b>	4" with 6mm rope		<b>Luff eyes:</b>	16-#3 eyelets									
<b>Leech Line:</b>	3mm Dacron line		<b>Insignia:</b>	Black 'Beneteau 323'									
<b>Reef Cleat:</b>	2 x 241 Alum.		<b>Bag Type:</b>	Drawstring type "a"									
<b>Reef Hts. %</b>	<b>Reef 1</b>	13.8%	<b>Reef 2</b>	30%	<b>Reef 3</b>	na							
<b>Reefing slots:</b>	None		<b>Foot /Leech Tape:</b>	Double tabling									
<b>Reef eyes:</b>	6- #2 eyelets		<b>Sail Ties:</b>	Yes, 2 x 2.4 mt ties									
<b>Mast Section:</b>	Z-Spar 401		<b>Boom Section:</b>	Z-Spar 360									
<b>Tack and Clew Cutback Details:</b>													
<b>A:</b>	40	<b>B:</b>	000	<b>C:</b>	200	<b>D:</b>	000	<b>E:</b>	25	<b>F:</b>	200	<b>G:</b>	120
<b>Drawing Information</b>													
<b>Drawing Name:</b>	323 classic	<b>Drawn By:</b>	Bob	<b>Date:</b>	Sept-03	<b>Rev:</b>	112732-rev0-cl mainsail.doc						
<b>Additional Notes:</b>	Production Model Classic Main												

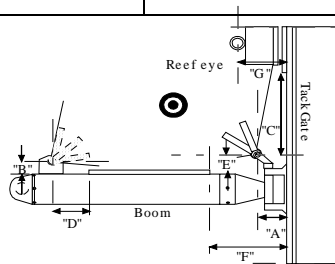

Tack/Clew Detail

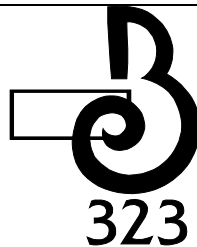

Insignia Detail in Black

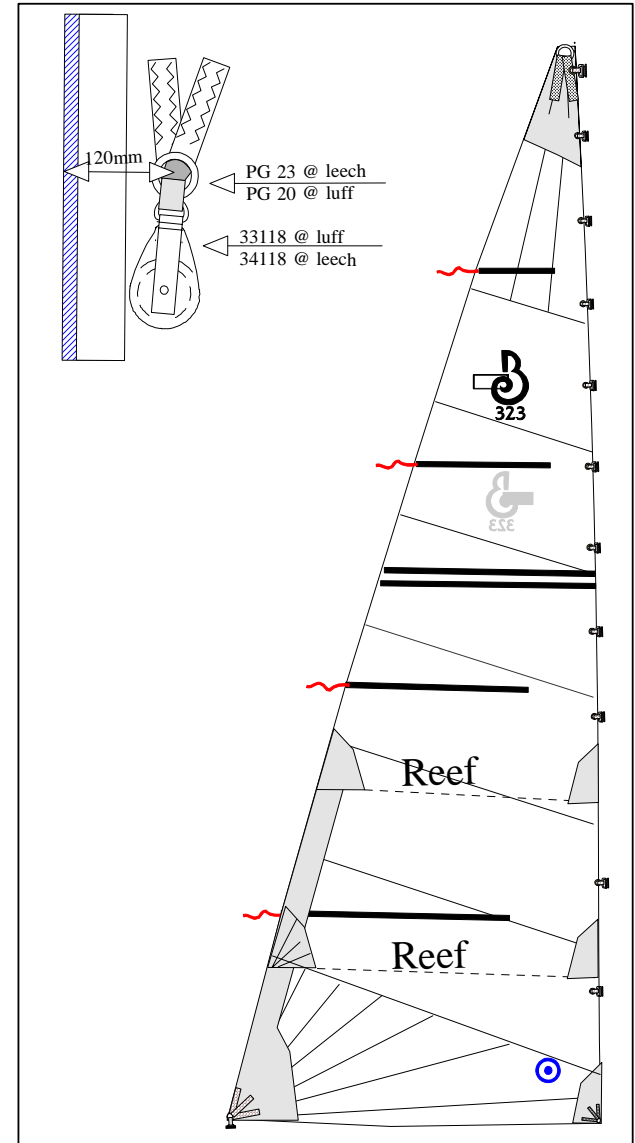

Beneteau Part #: 112732

## Beneteau 323 Classic Lazy Bag

**Notes:**

Cover: Forest Green Odyssey

1. Top section folded over to accept a 11mm round batten
2. Top sewn to seam. See detail
3. Openings for line notched in as shown.
4. Front flap to fold inside bag while sailing and Velcro to the interior of bag.
5. Web loops and buckle at fore and aft ends for tensioning. \*\*\*these should be sewn on the inside of the bag
6. Back of batten 'pocket' sewn closed.
7. Front needs to have internal velcro closure to keep batten in place.
8. One half of the top with extra tabling width to provide for zipper 'flap'.
9. One Bullseye on each side of bag
10. 2 number 2 eyelets on both sides of rear of bag for tensioning purposes

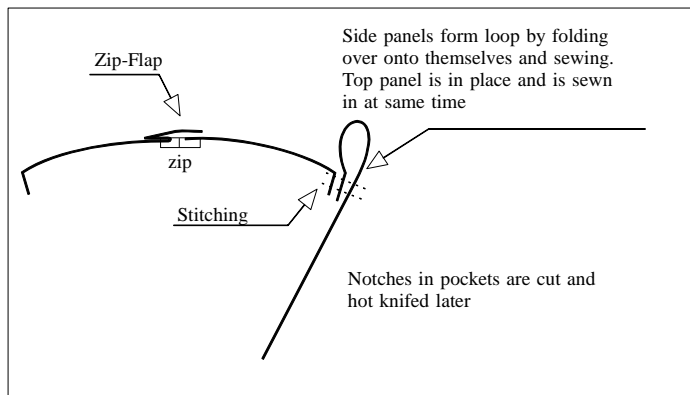

Zipper half to both sides and sewn to front  
Fore/aft zipper to pull FORWARD from aft end.

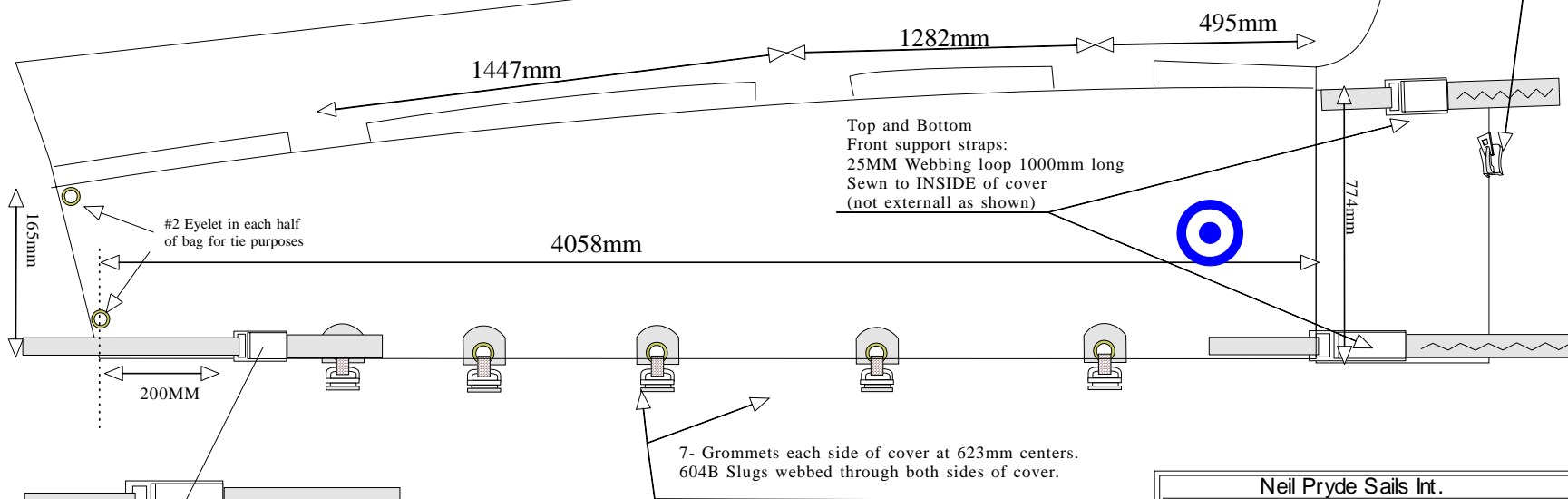

Buckle and loop 25mm x 500mm  
Loop goes through corner rings and back to other side of bag to allow for tensioning.  
**NOTE: BUCKLE TO BE SET INSIDE REAR OF COVER BY 200MM**

<b>Neil Pryde Sails Int.</b>			
354 Woodmont Rd #18			
Milford Conn. 06460 U.S.A.			
Phone: 203-874-6984 Fax: 203-877-7014			
Drawing Name:		323 Lazy Bag	
Date:	Sept -03	Scale:	Not to Scale
Drawn by:	Bob Pattison	Rev:	000
Copyright 2003 Neil Pryde Sails			

**Material List for BOTH SIDES**

4- 30mm rings

30mts of 5mm line

Lines will be tied around round batten stock that is exposed in cutouts

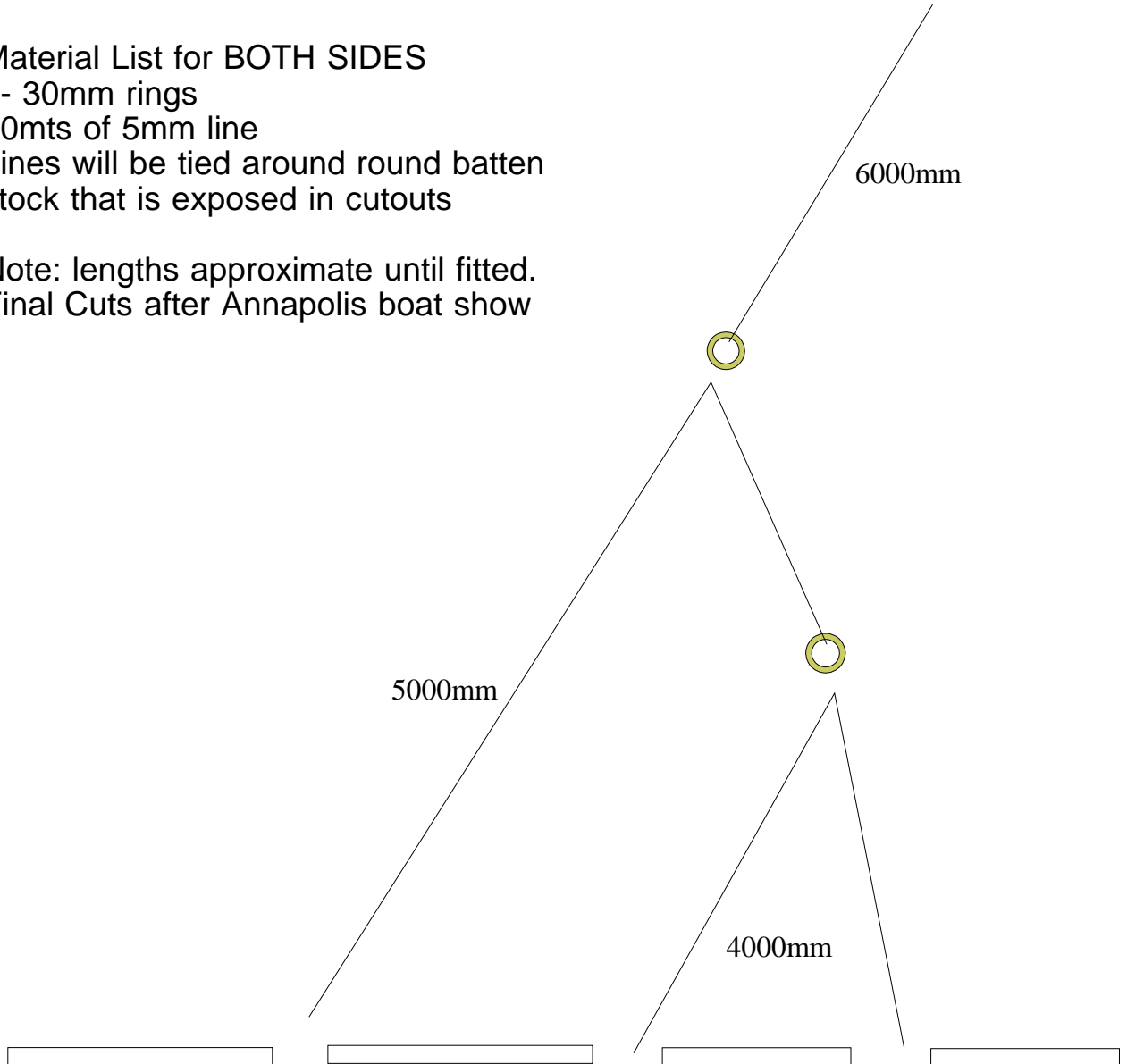
 Note: lengths approximate until fitted.  
 Final Cuts after Annapolis boat show

<b>Neil Pryde Sales &amp; Design Office</b>			
50 Broad Street, Milford Conn. 06460 U.S.A. Phone: 203-874-6984 Fax: 203-877-7014			
Drawing Name:		<b>323 Lazy Jack lines</b>	
Date:	Sept 03	Scale:	Not to Scale
Drawn by:		Bob Pattison	
Revision #:	000	File Name:	<b>393 Line</b>

# DECK LAYOUTS

## DECK LAYOUT FOR ROLLER FURLING MAST + OPTIONAL GENNEKER

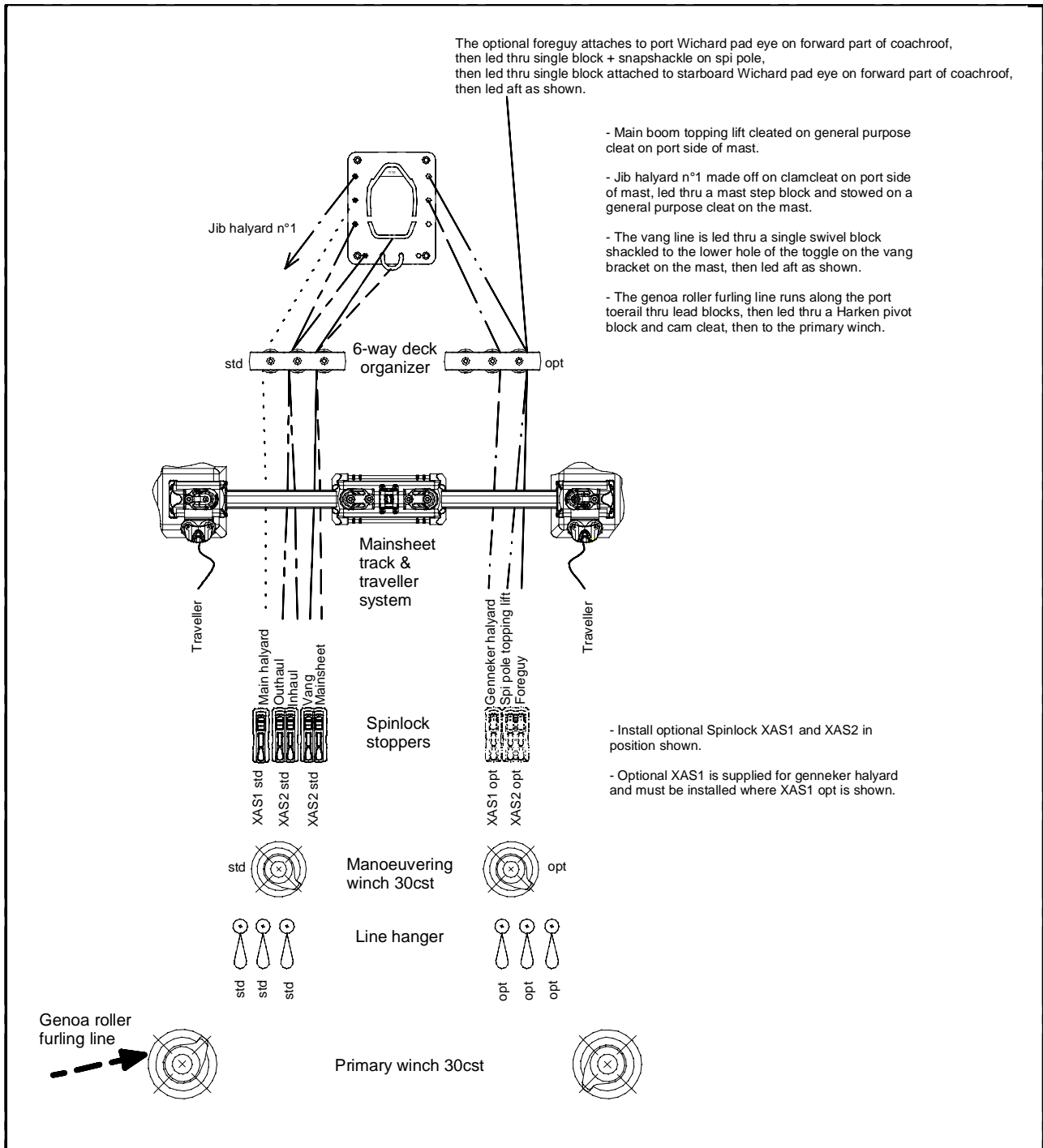

Material :		Dimension in mm :		Visa :
<p style="text-align: center;"><u>CAUTION</u> CAO <u>DRAWING</u></p>		Scale:		
		Gen.Tol.:		
		<b>MAST STEP, STOPPER &amp; WINCH LAYOUT</b> O323 RF		Design Date : 01/20/04
		<b>BENETEAU USA INC.</b> 1313 HIGHWAY 76 WEST PO DRAWER 1218 , MARION, SC 29571 Tel. (843) 423-4201 - Fax. (843) 423-4912		By : BDB
				Approved Date :
				By :
				Weight :
R	DESCRIPTION	By	DATE	N <sup>o</sup> 4323AU20
THIS DOCUMENT IS - PROPRIETARY AND REPRODUCTIONS MUST BE AUTHORIZED BY BENETEAU - DRAWN BY BENETEAU - SPECIFIED AND DESIGNED BY PRODUCT MANUFACTURER.				

# DECK LAYOUT FOR CLASSIC MAST + OPTIONAL GENNEKER

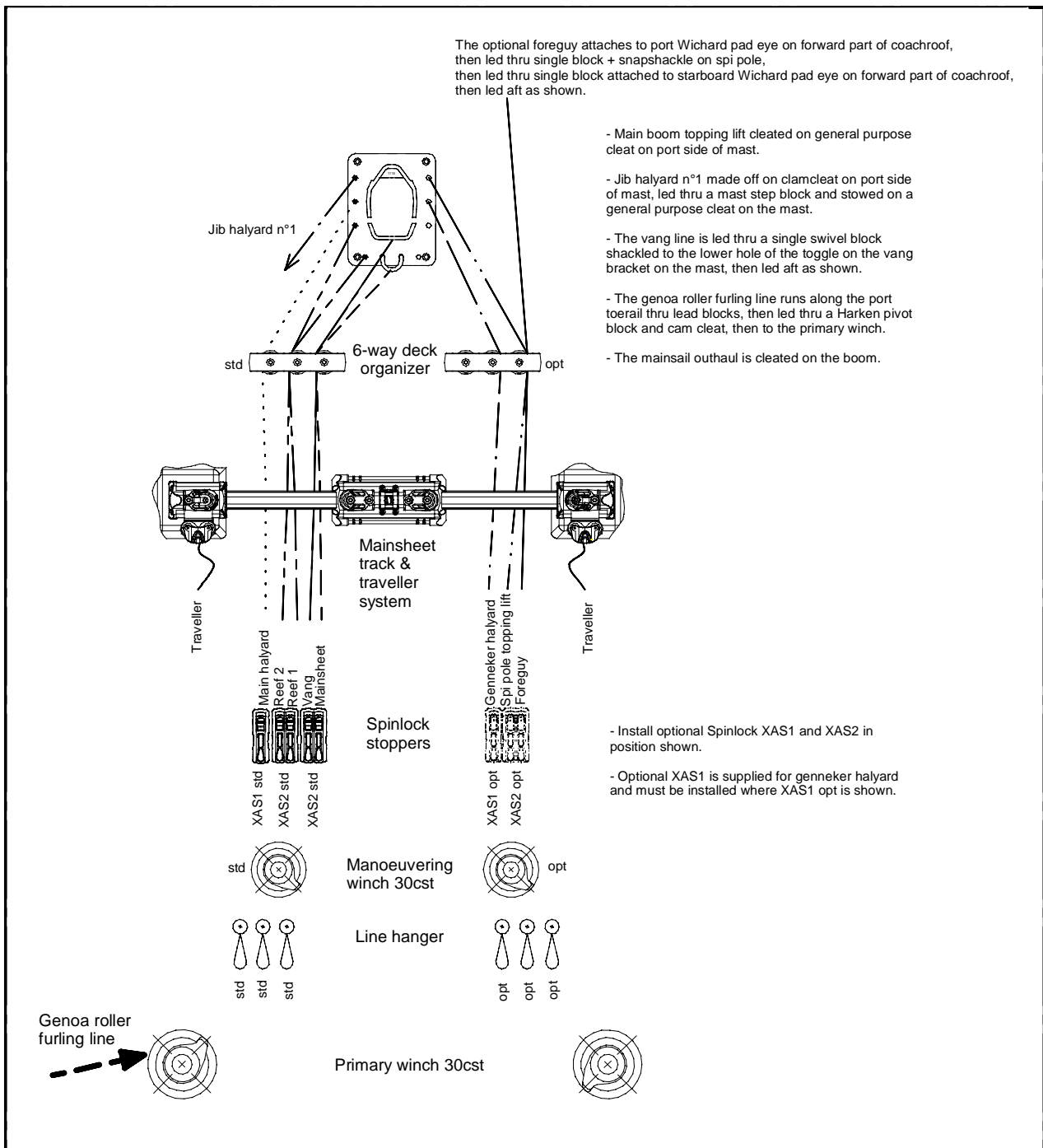

Material :		Dimension in mm :		Visa :	
		Scale:		Gen.Tol.:	
CAUTION CAO DRAWING		MAST STEP, STOPPER & WINCH LAYOUT O323 CL		Design Date : 01/20/04 By : BDB	
		<b>BENETEAU USA INC.</b> 1313 HIGHWAY 76 WEST PO DRAWER 1218 , MARION, SC 29571 Tel. (843) 423-4201 - Fax. (843) 423-4912		Approved Date : By :	
R	DESCRIPTION	By	DATE	Weight : <b>N<sup>o</sup> 4323AU10</b>	
THIS DOCUMENT IS - PROPRIETARY AND REPRODUCTIONS MUST BE AUTHORIZED BY BENETEAU - DRAWN BY BENETEAU - SPECIFIED AND DESIGNED BY PRODUCT MANUFACTURER.					

# MAINSHEET LAYOUT

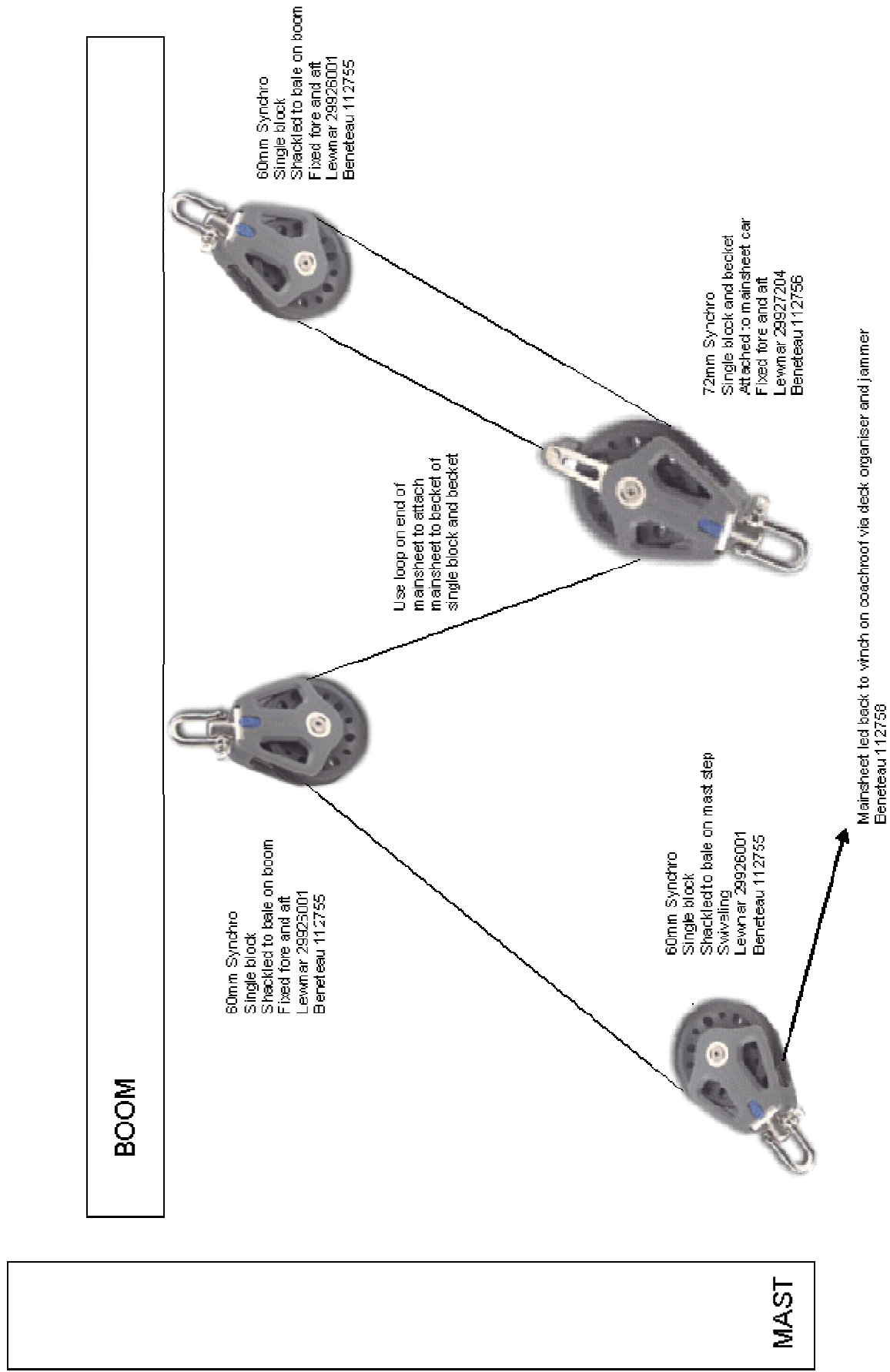

## VANG BRACKET ON MAST

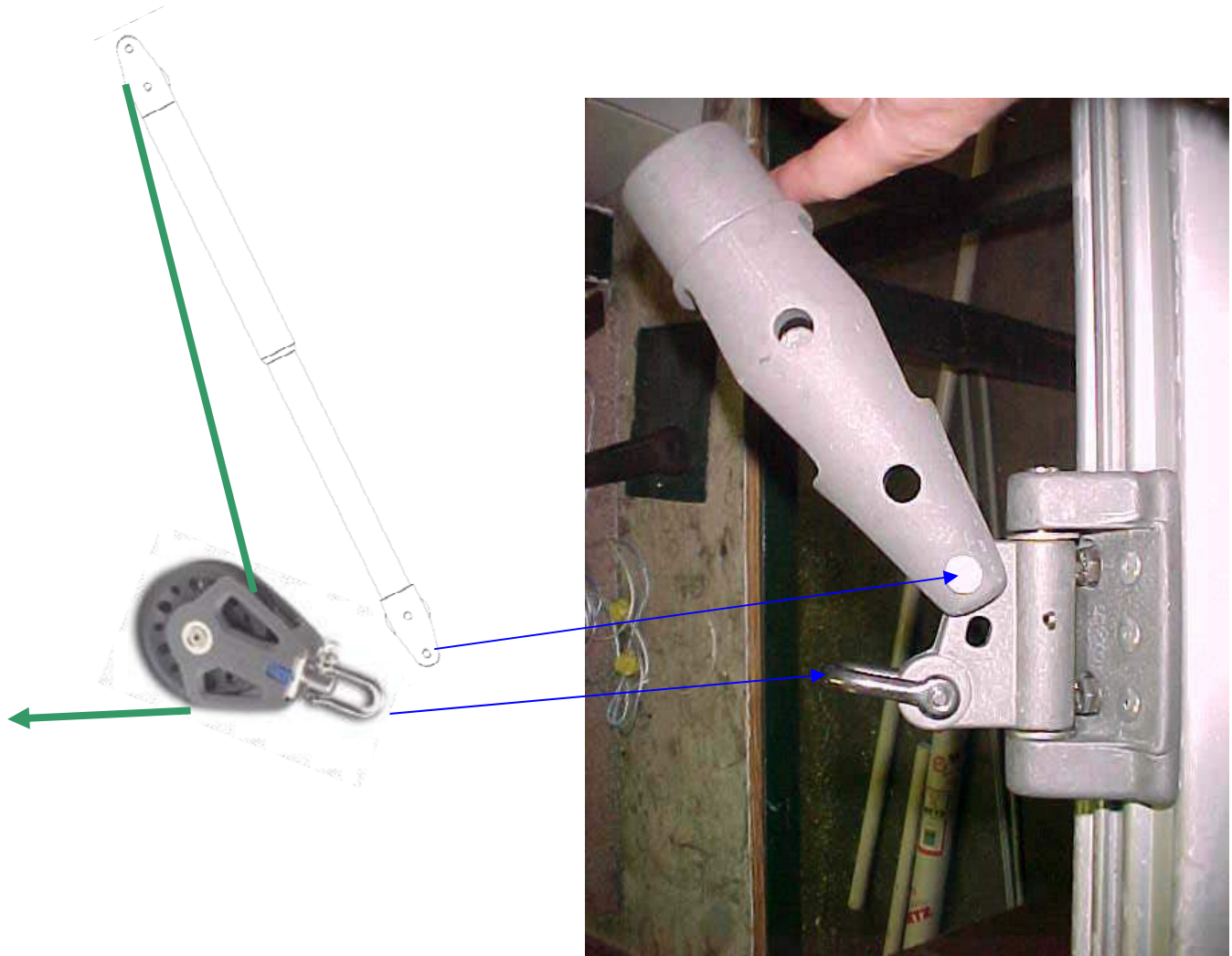

- Vang is pinned on the top hole of the toggle of the vang bracket.
- A single swivel block is shackled to the lowest hole of the toggle on the bracket.



# RUNNING RIGGING SPECS

ITEM PART No. (6 digit)	REV	QTY	DESCRIPTION	MAKE & TYPE	COL.	TERMINAL 1	TERMINAL 2	NOTES	DIA	LENGTH mm	FEET	IN
024173	00	2	JIB SHEET	LANCELIN	BLACK	WHIPPING	WHIPPING		10mm	10000	32	9 11 / 16
112758	00	1	MAINSHEET	SAMSON LS	GREY	SOFT EYE	WHIPPING		3/8"	18000	59	0 5 / 8
112761	00	2	MAINSHEET TRAVELLER CONTROL LINE	SAMSON LS	WHITE	SOFT EYE	WHIPPING		5/16"	6000	19	8 3 / 16
112599	00	1	GENNEKER HALYARD	SAMSON LSTC	RED	SOFT EYE SNAPSHOTACKLE W2475	WHIPPING AND LOOP		3/8"	30000	98	5 1 / 16
112572	00	1	GENNEKER TACK STROP	SAMSON LSTC	BLACK	BURNT	BURNT		3/8"	7000	22	11 9 / 16
112580	00	2	GENNEKER SHEET - twin sheet system	SAMSON LSTC	RED	BURNT	BURNT		3/8"	22000	72	2 1 / 8
	00	1	JIB HALYARD #1	GLEISTEIN TASMANIA	BLUE	KNOT + 7MM ZSPAR 3639 D SHACKLE	BURNT		10mm	29200	95	9 9 / 16
	00	1	MAIN HALYARD - classic mast	GLEISTEIN TASMANIA	RED	KNOT + 7MM Zspar 3639 D shackle	BURNT		10mm	30300	99	4 7 / 8
	00	1	MAIN HALYARD - roller furling mast	GLEISTEIN TASMANIA	RED	KNOT + 6MM ZSPAR 56 D SHACKLE	BURNT		10mm	30300	99	4 7 / 8
	00	1	MAIN BOOM TOPPING LIFT	GLEISTEIN TASMANIA	YELLOW	KNOT + 6MM ZSPAR 3212 D SHACKLE	BURNT		6mm	27300	89	6 13 / 16
	00	1	VANG LINE	GLEISTEIN TASMANIA	GREEN	BURNT	BURNT	1. standard - supplied with vang.	8mm	12000	39	4 7 / 16
	00	1	MAIN RF INHAUL LINE	GLEISTEIN TASMANIA	BLUE	BURNT	BURNT		10mm	18000	59	0 5 / 8
	00	1	MAIN RF OUTHAUL LINE	GLEISTEIN TASMANIA	BLACK	BURNT	BURNT		10mm	15600	51	2 3 / 16
	00	1	OUTHAUL AFT LINE - classic mast	GLEISTEIN TASMANIA	BLACK	BURNT	BURNT		8mm	3000	9	10 1 / 8
	00	1	OUTHAUL FWD LINE - classic mast	GLEISTEIN TASMANIA	BLACK	KNOT + ZSPAR 253 SINGLE+BECKET BLOCK	BURNT		8mm	11000	36	1 1 / 16
	00	1	REEF 1 - classic mast	GLEISTEIN TASMANIA	RED	BURNT	BURNT		10mm	19600	64	3 5 / 8
	00	1	REEF 2 - classic mast	GLEISTEIN TASMANIA	BLUE	BURNT	BURNT		10mm	27400	89	10 3 / 4

## **XIV) FRESH WATER SYSTEM**

The fresh water system supplies the sink in the galley, the wash basin and shower in all of the heads, and the transom shower. This system is pressurized by an electric pump. There is a filter between the water tank manifold and the pump. It is necessary to check and clean this filter regularly.

**Never run an electric pump when the tank is empty. It may burn out the pump.**

### **OPERATION.**

1. Fill the water tanks. **(SEE DECK SECTION FOR WATER FILL LOCATIONS)**
  2. Select the tank for use at the valves on the manifold.
  3. Turn on the fresh water pump at the panel.
  4. Open all taps and bleed off any trapped air in the lines until the water runs clear with no sputtering.
  5. Close all taps and the pump will turn off when it reaches operating pressure. If the pump continues to cycle check all fittings for leaks.
- Never fill up with water and diesel at the same time if the filling points are close to each other, to avoid the risk of contaminating one liquid with the other.
  - Similarly, avoid risk of contamination by never handling a product that might cause pollution close to the deck fill while taking on water.
  - If unused for a long time, the tanks and pipes need to be flushed with a solution of acetic acid (solution of vinegar and water).
  - The sink and washbasins are drained through their own thru-hull valves; these should be kept closed when the fresh water system is not in use.
  - Do not force hosepipe nozzle down the fill pipe as a high back pressure could occur. Check the vent/overflow fitting to avoid over filling.

# LAY OUT OF THE FRESH WATER SYSTEM

## ALL VERSIONS

### FRESH WATER FILL AND TANK CIRCUIT

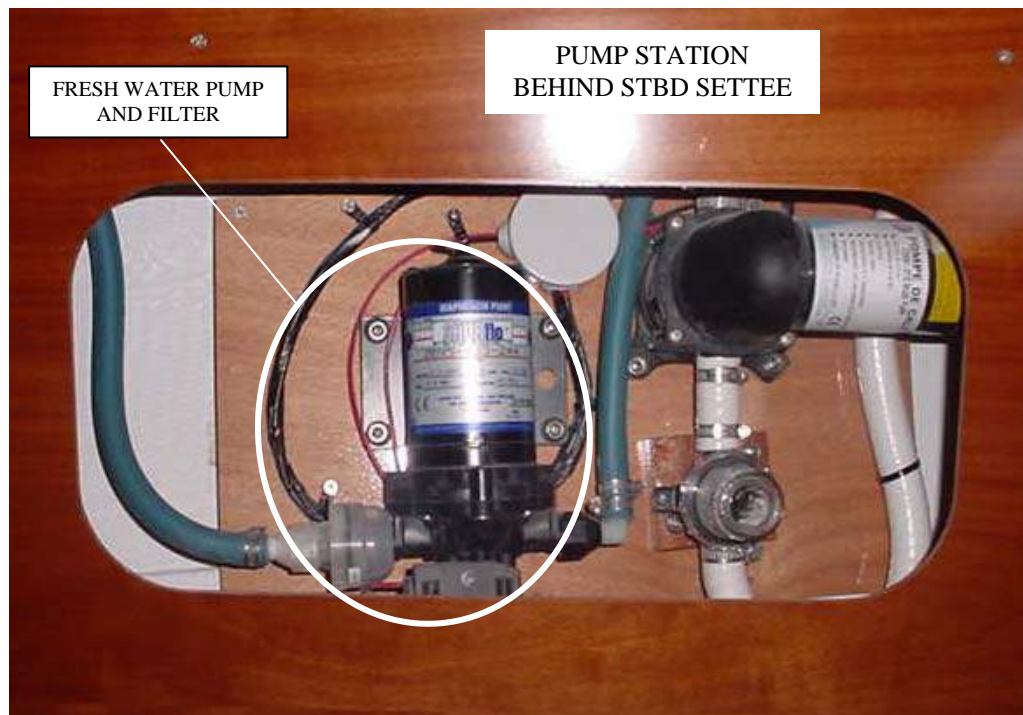
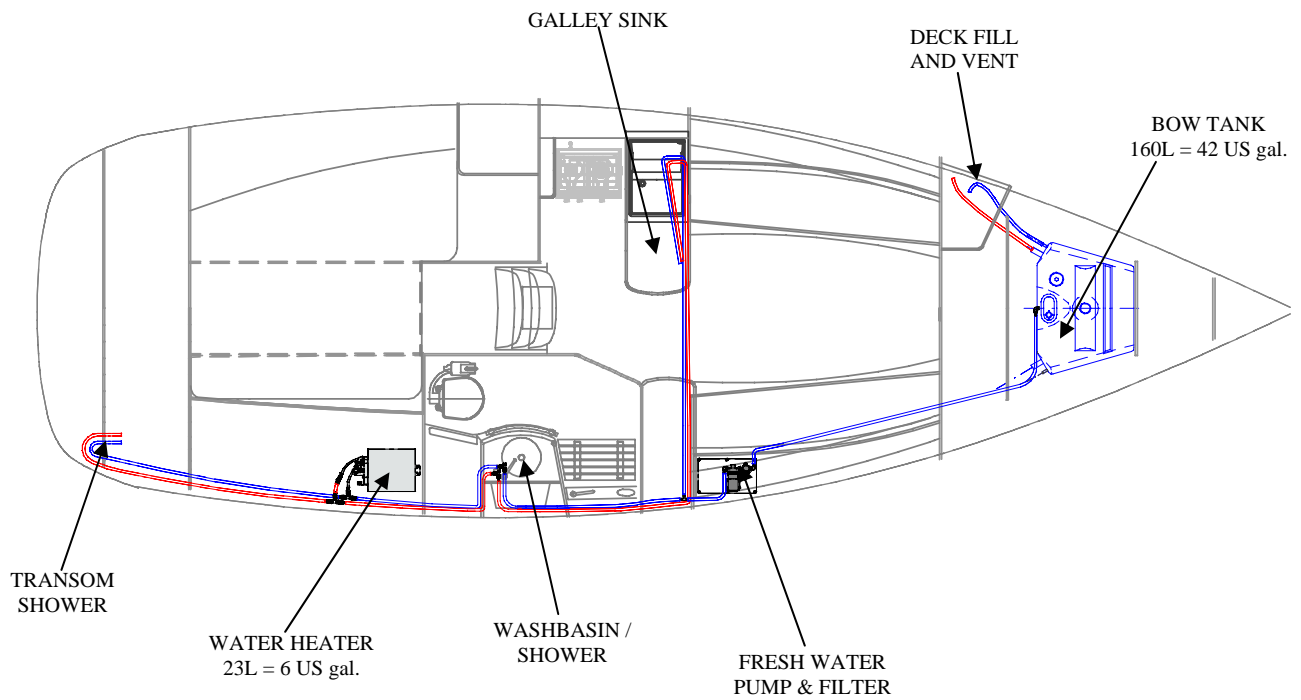

## XV) BILGE PUMP SYSTEM

### OPERATION

The pump is normally automatic but can be controlled manually from a switch on the main 12V panel. There is also a reset push button on the panel. Be sure to clean the filter between the pump and sump carefully, at regular intervals. To clean the filter, unscrew the body and wash out the filter screen.

**WARNING! BE CAREFUL NOT TO WASH THE O-RING SEAL OUT OF THE FILTER.**

**Make sure the bilge pump system is in good working order before you put out to sea.**

Acquaint yourself with the way the bilge pump system of your boat works:

- Locate the manual bilge pump and the handle.
- Locate the switch of the electric bilge pump.

(See the lay out drawing of the system - next page)

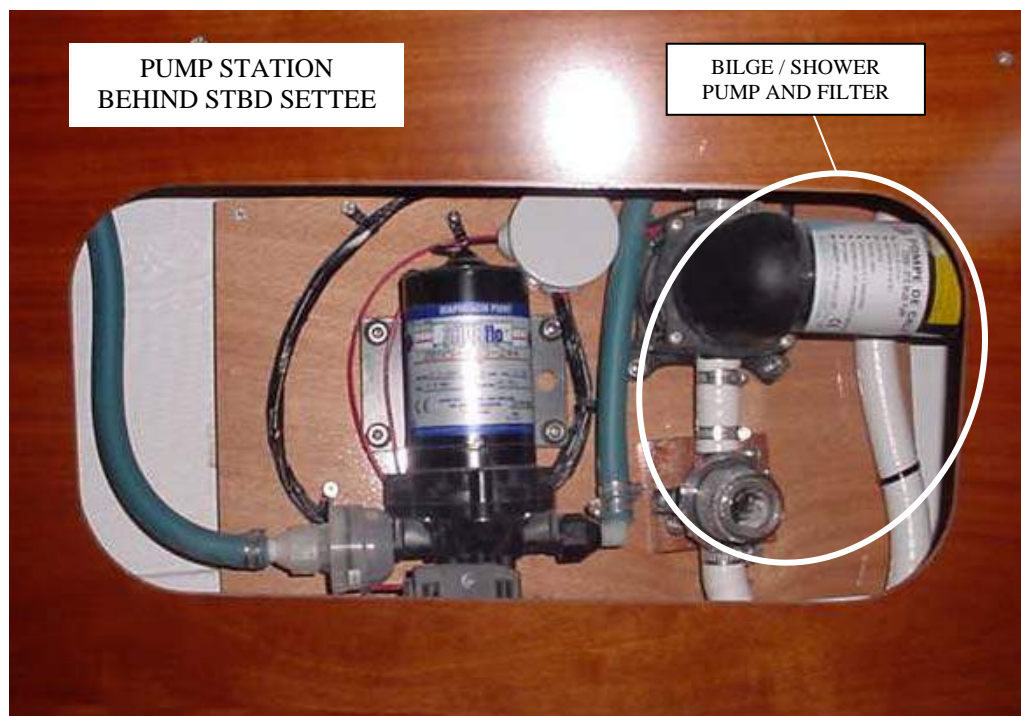

# LAY OUT OF THE BILGE PUMP / SHOWER DRAIN SYSTEM

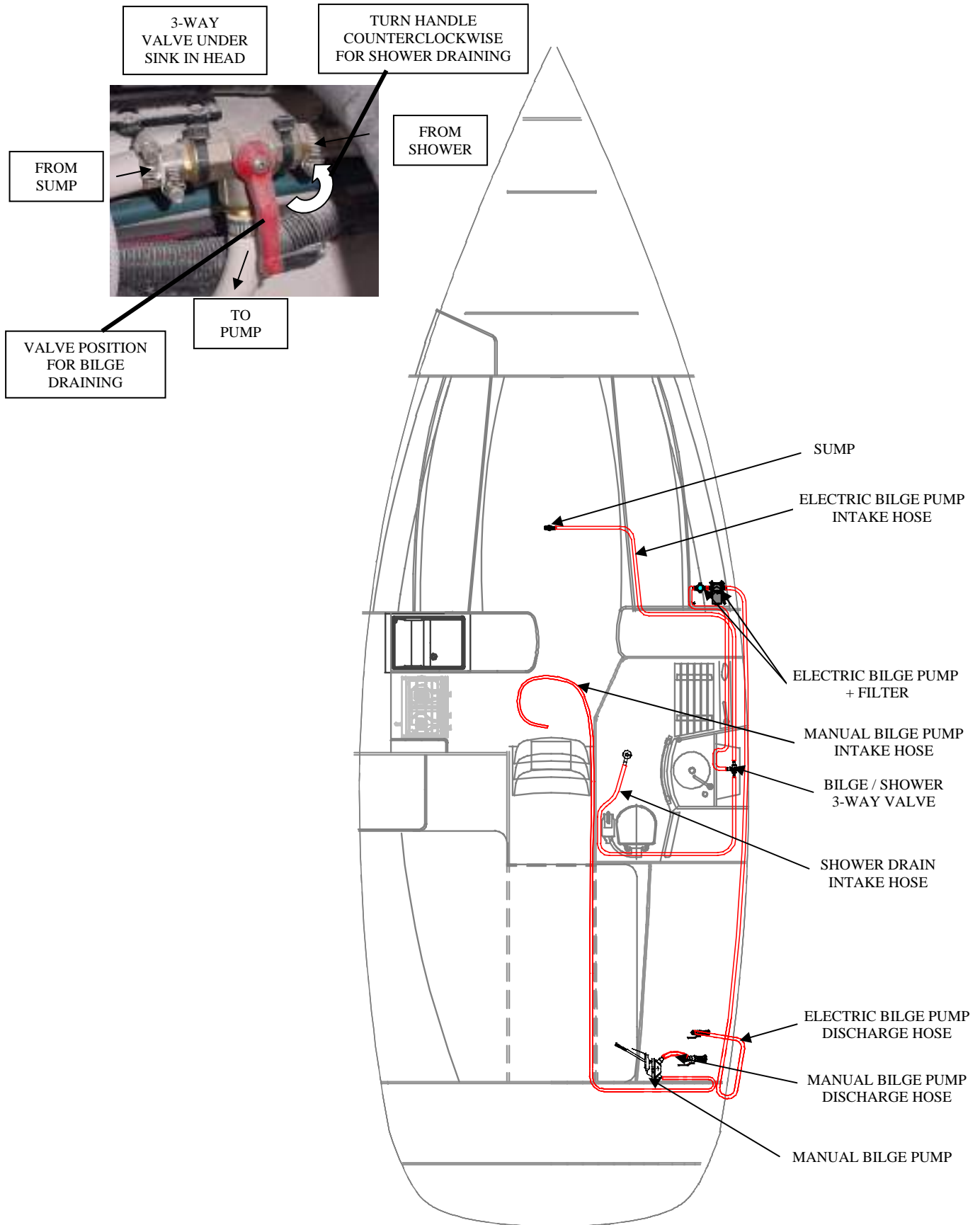

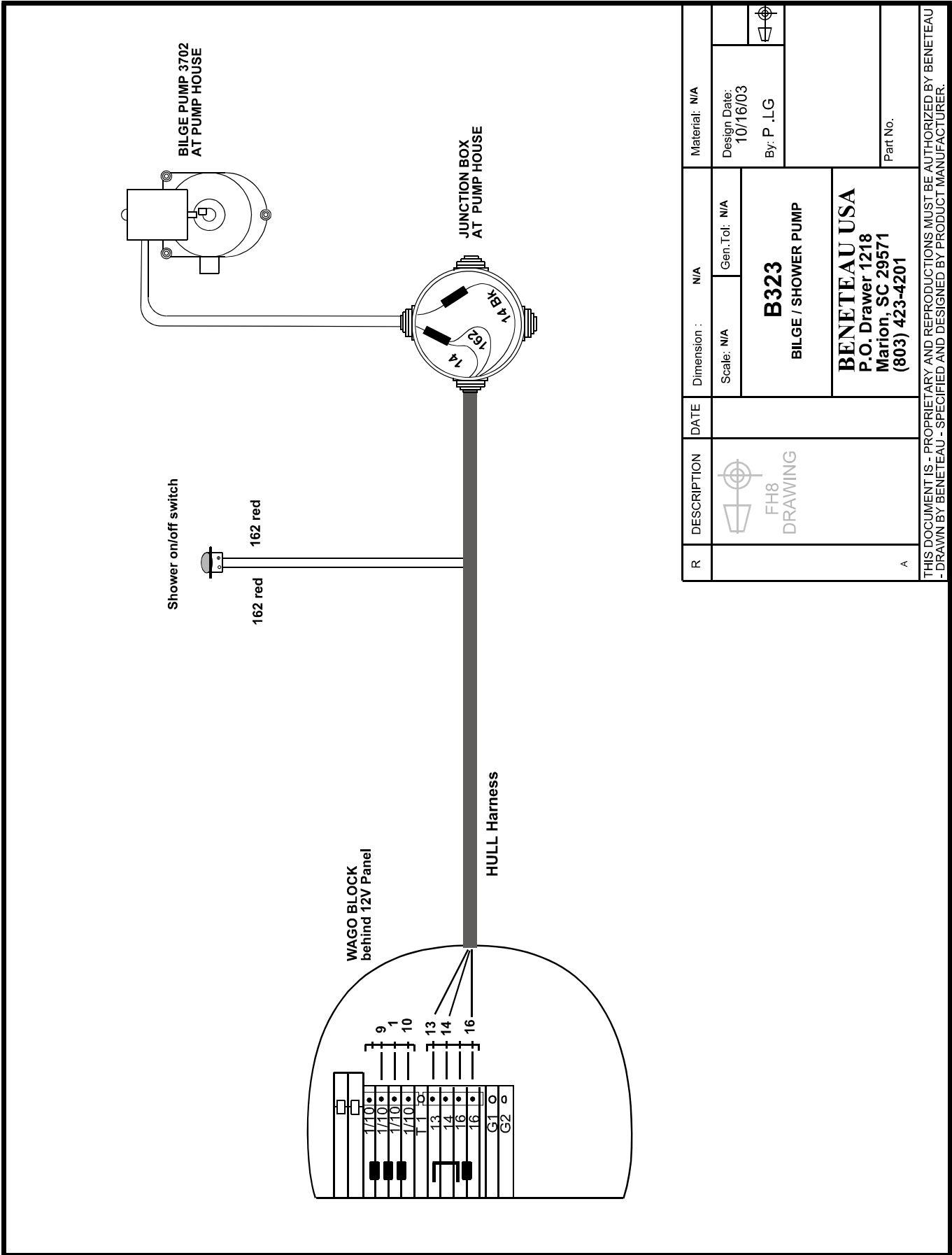

R	DESCRIPTION	DATE	Dimension :	Material: N/A
	FH8 DRAWING		Scale: N/A	Design Date: 10/16/03
			Gen.Tol: N/A	By: P .LG
			<b>B323</b> BILGE / SHOWER PUMP	
			<b>BENETEAU USA</b> P.O. Drawer 1218 Marion, SC 29571 (803) 423-4201	
A				Part No.

THIS DOCUMENT IS - PROPRIETARY AND REPRODUCTIONS MUST BE AUTHORIZED BY BENETEAU - DRAWN BY BENETEAU - SPECIFIED AND DESIGNED BY PRODUCT MANUFACTURER.

## XVI) SEACOCKS AND THRU-HULLS

### GENERAL DESCRIPTION

The thru hulls that are below the water line have 1/4-turn valves, which must be opened only during use. The quarter-turn valve is open when the lever is in line with the pipe, and closed when it is at right angles.

### Safety - Maintenance

Take special care to see that these valves are well maintained, have a good seal and work smoothly. Have a wooden tapered plug, of correct diameter at hand, so that they can be plugged on the outside if, for instance, a seized valve has to be dismantled, or lubricated.

After hot water has been run through a pipe for the first time, check the tightness of all the clamps.

**NOTE: THESE RECOMMENDATIONS ALSO APPLY TO THE COOLING SYSTEM OF THE INBOARD ENGINE**

**Close all the seacocks when you leave the boat.**

**The toilet is situated below the waterline; get into the habit of systematically closing the seacocks after each use.**

Make sure that all seacocks, which are not used, are closed before you put out to sea.

Opening and closing of the seacocks



Open

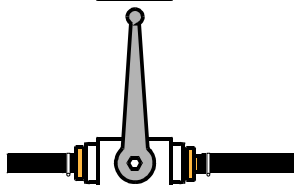

Closed

REF	DESCRIPTION
1	Head Discharge
2	Head Intake
3	Washbasin Discharge
4	Optional Waste Tank Discharge
5	Galley Sink Discharge
6	Engine Cooling Water Intake
7	Ice Box Draining
8	Stern Tube Cooling Intake Valve
9	Speed/Log, Depth Sounder Thruhulls
10	Electric Bilge Drain
11	Manual Bilge Drain
12	Exhaust
13	LPG Locker Drain (on transom)

# SEACOCK AND THRU-HULL LAY OUT

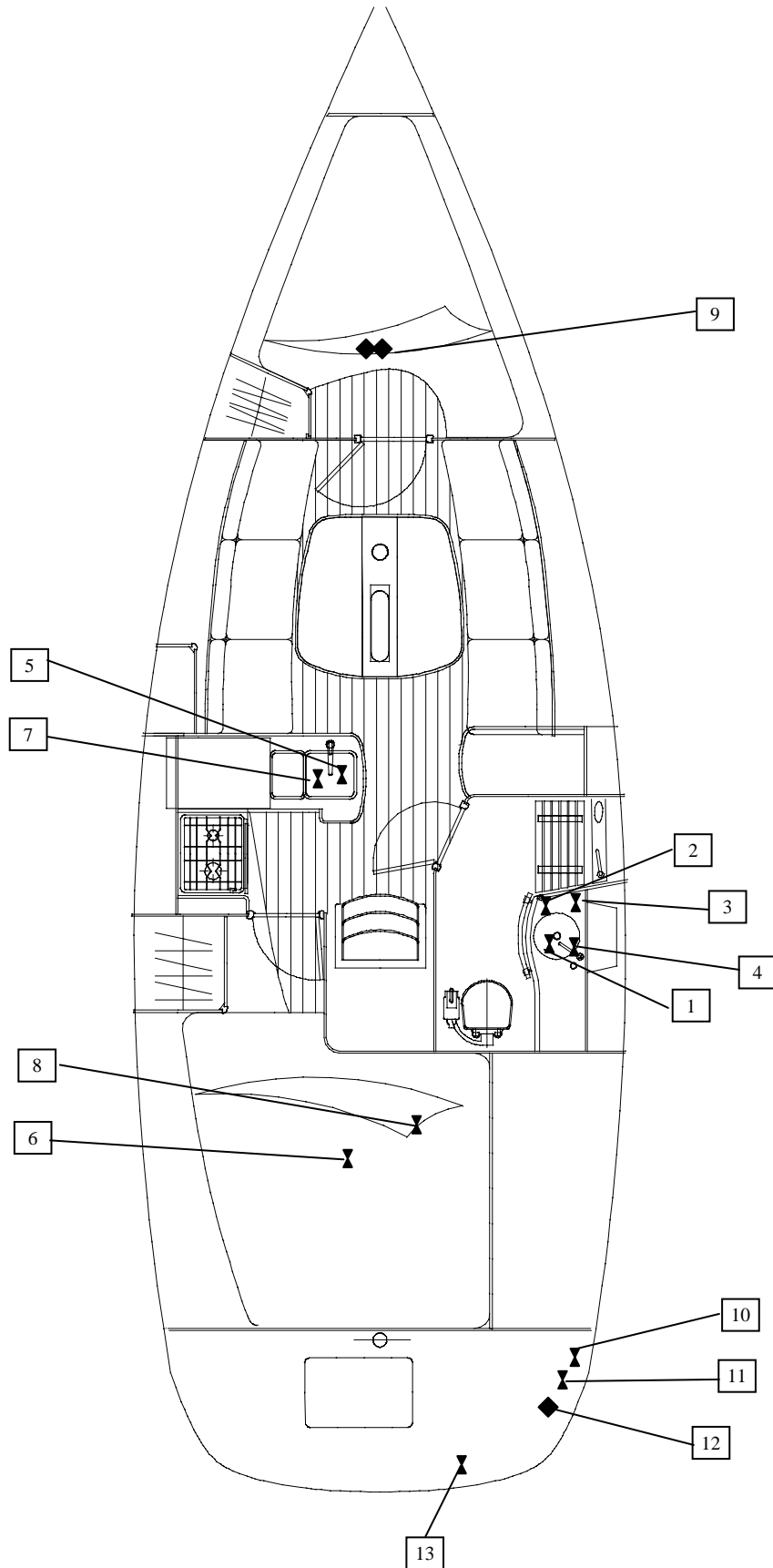



## XVII) MARINE TOILET & HOLDING TANK

### GENERAL DESCRIPTION

The marine sanitary system consists of a marine toilet (head), a holding tank and a series of thru hull intakes, discharges and valves to control the intake of water into the head to flush the bowl either into the holding tank or overboard.

### Head Operating Procedure

**The marine heads on your Beneteau are installed below the water line, all valves must be closed after use and the selection lever on the head must be returned to the dry bowl position. Failure to do so could result on the bowl overflowing and flooding the boat with water.**

1. Read the instructions for use supplied by the head manufacturer and the precautions marked on the pump.
2. Before use, make sure that the water supply thru-hull valve is open and the Y-valve is selected for discharge into the holding tank.

**NOTE: BY LAW YOU MUST USE A HOLDING TANK IN ALL US WATERS.**

3. Check with local authorities for regional laws governing your area before selecting the overboard discharge option. If you choose overboard discharge option, be sure the discharge thru-hull valve is open before using the head. Select the overboard discharge position on the Y-valve.
4. Select "Flush Bowl" with the selection lever on top of the pump body and pump the handle until the bowl is flushed clean. Return the selection lever to "Dry Bowl" and pump the handle until the bowl is dry. Limiting pump strokes will maximize the use of the holding tank.
5. **CLOSE THE VALVES AFTER USE.**

### Holding Tank Pump Out Procedure

The holding tanks are pumped out through deck plates located on the deck. (Unless an additional draining option has been installed; macerator pump, manual pump, gravity drain) Consult your dealer or your marina for the closest pump out facility in your area.

**(SEE DECK SECTION FOR LOCATION OF PUMP OUT DECK FITTINGS)**

1. Open the deck plate with a winch handle and insert the pump out hose into the deck fill,
2. Follow the pump out stations operating procedure to pump all of the effluent from the tank.
3. Flush the tank by pumping water thru the head into the tank or by inserting a hose into the deck fitting to add fresh water and then pump the tank again.
4. Close the deck fitting.

### Operation of three-way valve for toilets

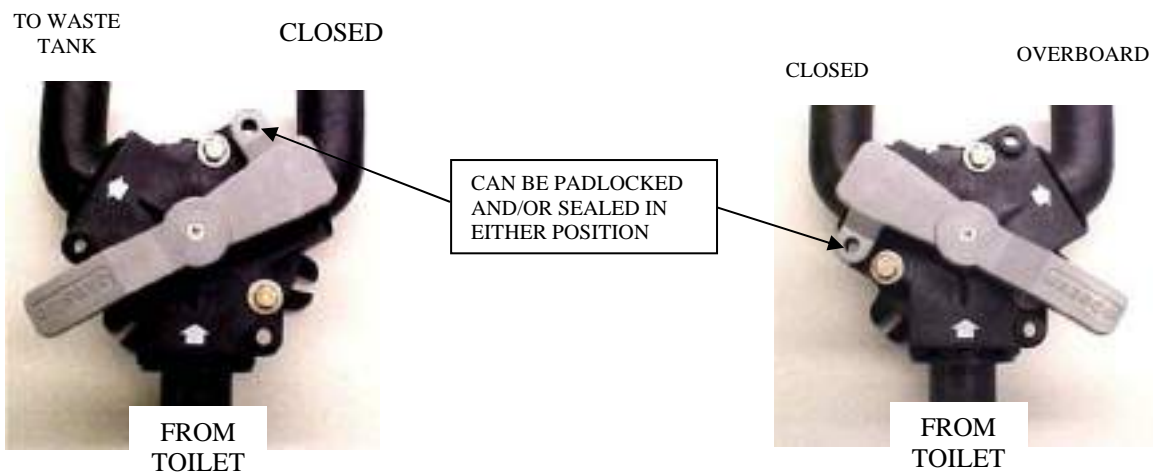

# WASTE TANK LOCATION

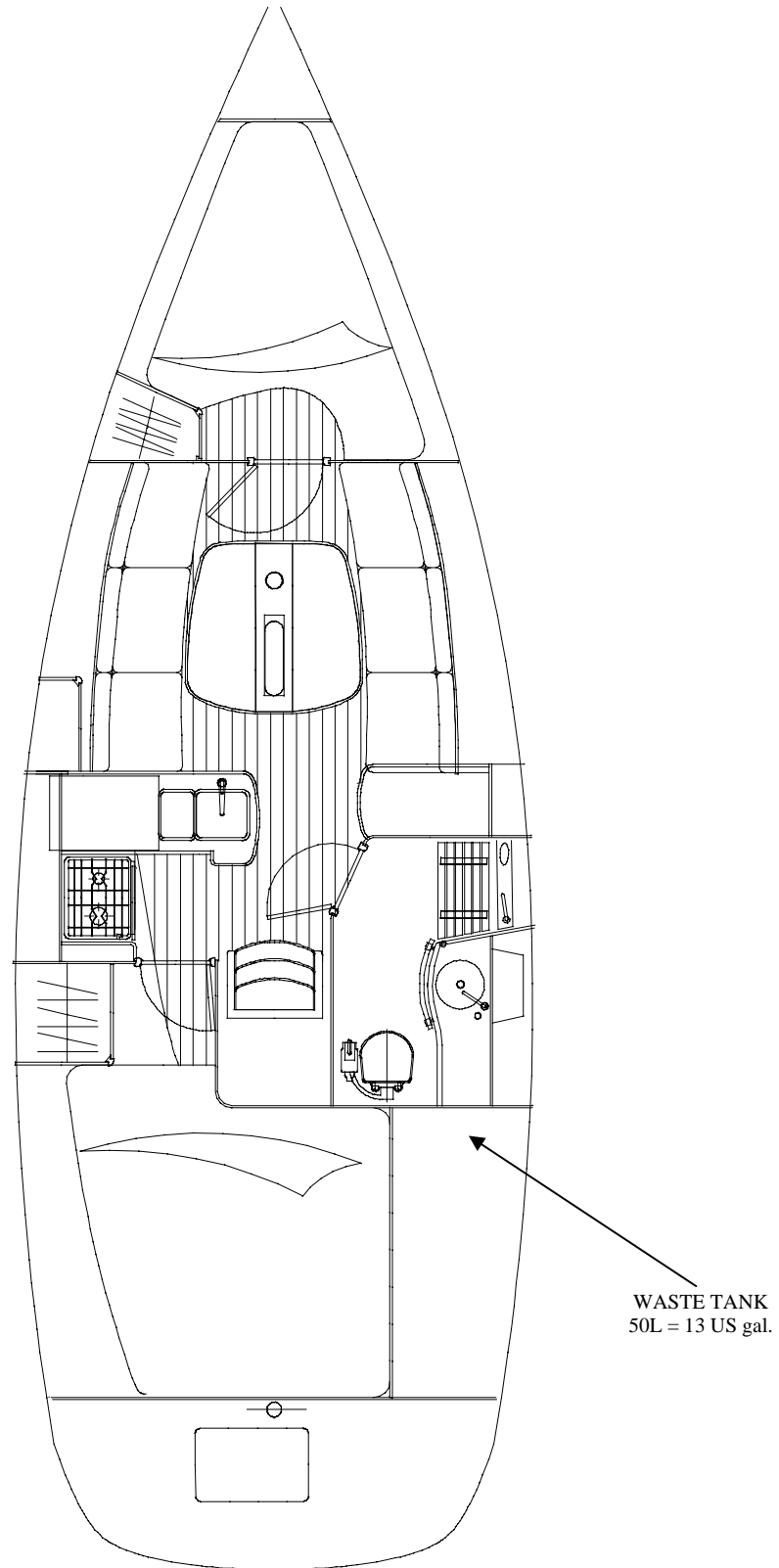

# MACERATOR (OPTION)

## OPERATION

This macerator waste tank drain system is designed as an independent draining system for the waste tank.

The 12V macerator pump, pumps out the waste tank via a pick-up tube mounted in the waste tank in less than 3 minutes using an intermittent switch and its own thru-hull.

The system has a breaker on the 12V panel to provide power, but the system is operated by a momentary switch in the head.

This system can be operated only in an unrestricted discharge area.

The pump must not run dry for longer than 15 seconds as the pump impeller will fail due to excess heat.

**NOTE: BY LAW YOU MUST USE A HOLDING TANK IN ALL US WATERS.**

Check with local authorities for regional laws governing your area before electing to discharge waste using this option.

Be sure to open the valve at the thru-hull before use and make sure it is closed after the tank has been drained.

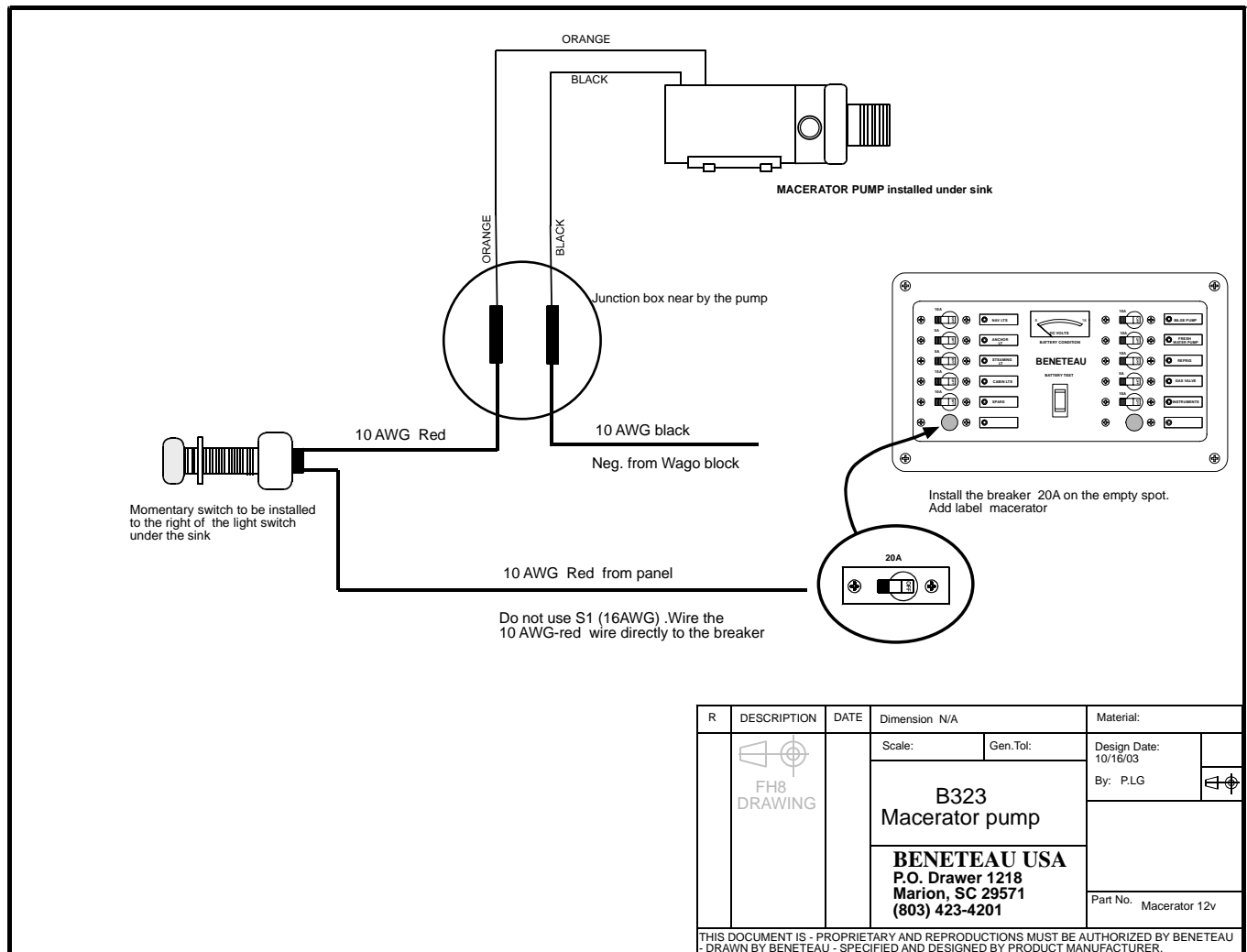

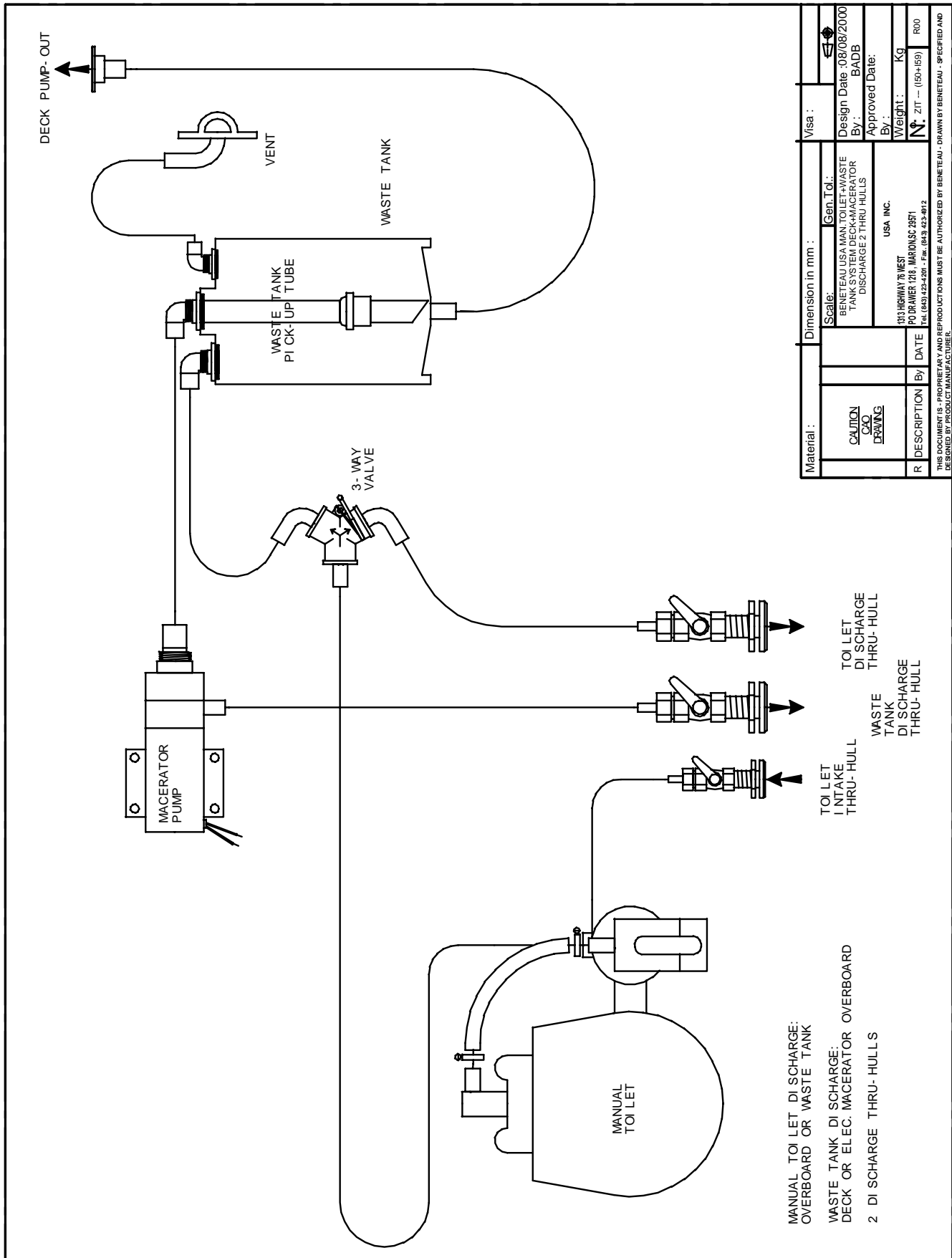

MANUAL TOILET DI SCHARGE:  
OVERBOARD OR WASTE TANK

WASTE TANK DI SCHARGE:  
DECK OR ELEC. MACERATOR OVERBOARD

2 DI SCHARGE THRU-HULLS

Material :		Dimension in mm :		Visa :	
CAUTION CRO DRAWING	R DESCRIPTION	Scale:	Gen. Id.:	Design Date :	08/08/2000
		BENETEAU USA MAN. TOILET+WASTE TANK FOR DISCHARGE 2 THRU HULLS		By :	BADB
DATE		USA INC.		Approved Date:	
BY		313 HIGHWAY 78 WEST PO BOX 1218, WILKINSON SC 29571 Tel: (843) 422-4201 - Fax: (843) 422-4912		Weight :	Kg
				N. ZIT --	(150+159)
				R00	

THIS DOCUMENT IS - PROPRIETARY AND REPRODUCTIONS MUST BE AUTHORIZED BY BENETEAU - DRAWN BY BENETEAU - SPECIFIED AND DESIGNED BY PRODUCT MANUFACTURER.

## XVIII) ELECTRIC SYSTEMS

### 12V ELECTRIC SYSTEM

#### 12 Volt Distribution Panel

The 12V power from your batteries is distributed throughout your boat via a distribution panel. This panel separates the current into separate circuits. Each circuit is protected by an individual breaker switch which allows you to turn the individual circuits on or off as needed at the panel. Each breaker switch has an individual amperage rating which it is designed to trip at in case it is overloaded.

Never work on a live electric fitting.

Never tamper with an electric fitting. Call in a technician qualified in marine electricity.

The batteries must be carefully and safely stowed.

In order to prevent a short circuit between the battery terminals, do not store conductive objects near the batteries (e.g. metal tools, ...)

Never alter the specifications of the breakers, which protect against overload.

Never fit or replace the electric materials or appliances with components, which exceed the system amperage.

#### Terminal Block

The panel is wired to the boat thru a wago block strip. The boat's wiring harness and the panel are connected together at the wiring block strip using a series of plugs from each that snap onto opposite sides of the wiring block strip. Each of the boats positive 12V circuits connect to it's circuit breaker in the panel this way, i.e.: Wire #7 'Deck Light' connects across the wiring block to circuit breaker #7 on the panel. The negative side of the circuits lead to a common ground.

Each strip on the wago wiring block is an individual block mounted side by side on a frame to form the wiring block strip. These individual blocks can be connected to the blocks on either side of it to create a larger circuit as in the saloon lights. Wires are inserted into the block by:

1. Inserting a small screwdriver into the inside hole and pressing down.
2. Insert the wire.
3. Remove the screwdriver

Remove wires by inserting the screwdriver and pulling out the wire.

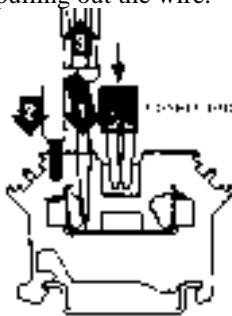

#### Batteries

The amount of charge the battery is receiving can be checked on the voltmeter, which is graduated in volts. This should be done when the battery is cold (has not been recharged or used for several hours beforehand). A reading of less than 11.5 V means that recharging is necessary.

**WARNING! NEVER OPERATE ISOLATING SWITCHES WHILE THE ENGINE IS RUNNING - DOING SO COULD DAMAGE THE ALTERNATOR DIODES AND REGULATOR BEYOND REPAIR.**

## 12V Charging System

The batteries must be recharged by one of the following systems:

### Alternator

A belt drive alternator is mounted to the engine which produces 12V as needed by the batteries when the engine is running. The output of the alternator is wired to the battery switches.

### Battery Charger

A marine battery charger is wired into the 110V shore power system. This charger converts the AC dock power to 12V DC and feeds it to the batteries.

**WARNING! DO NOT OPERATE THE CHARGER WHEN THE ENGINE IS RUNNING.**

The battery charger is completely automatic; refer to the charger's manual for complete details. To charge the batteries using the charger: plug in the shore power cord and turn the charger breaker on at the 110V shore power panel.

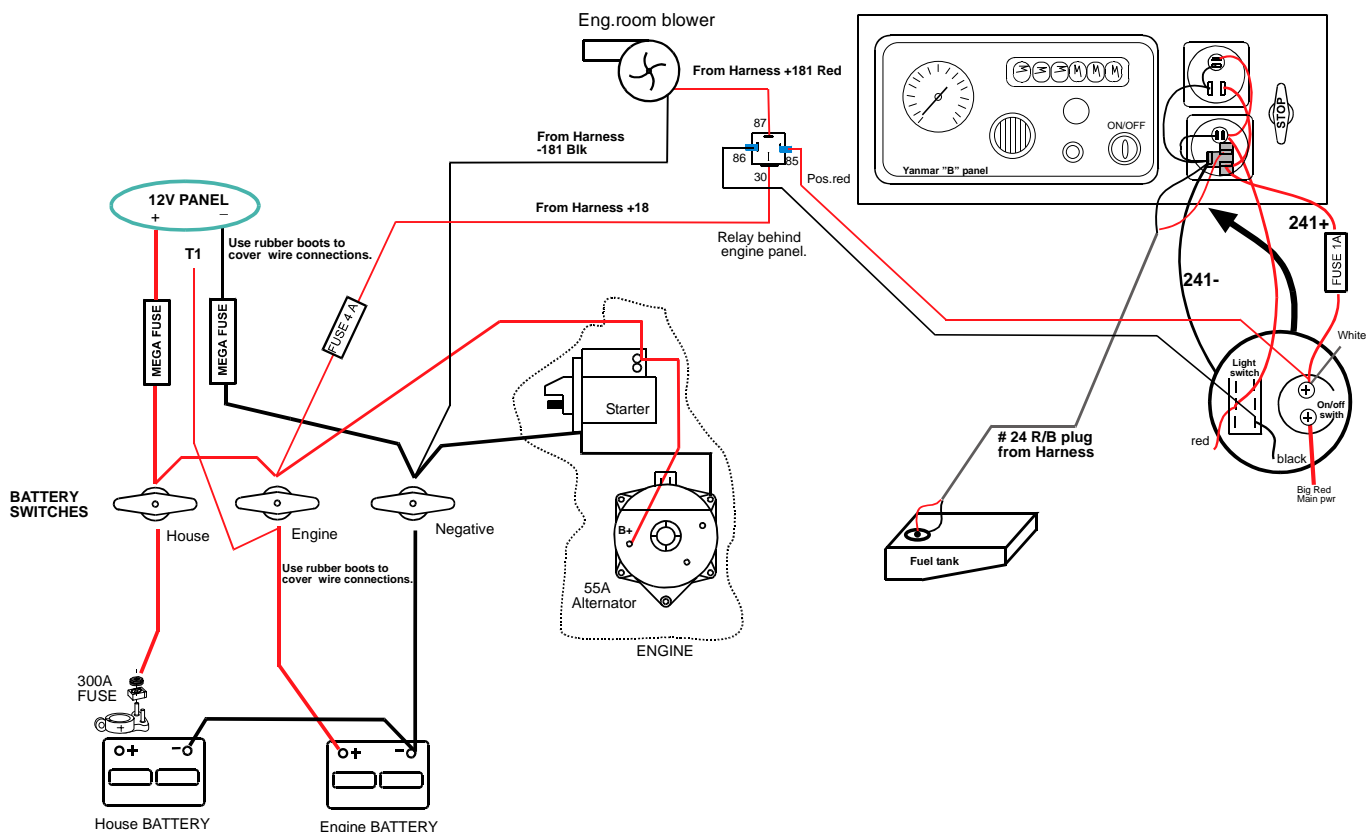

## Electricity Lay Out

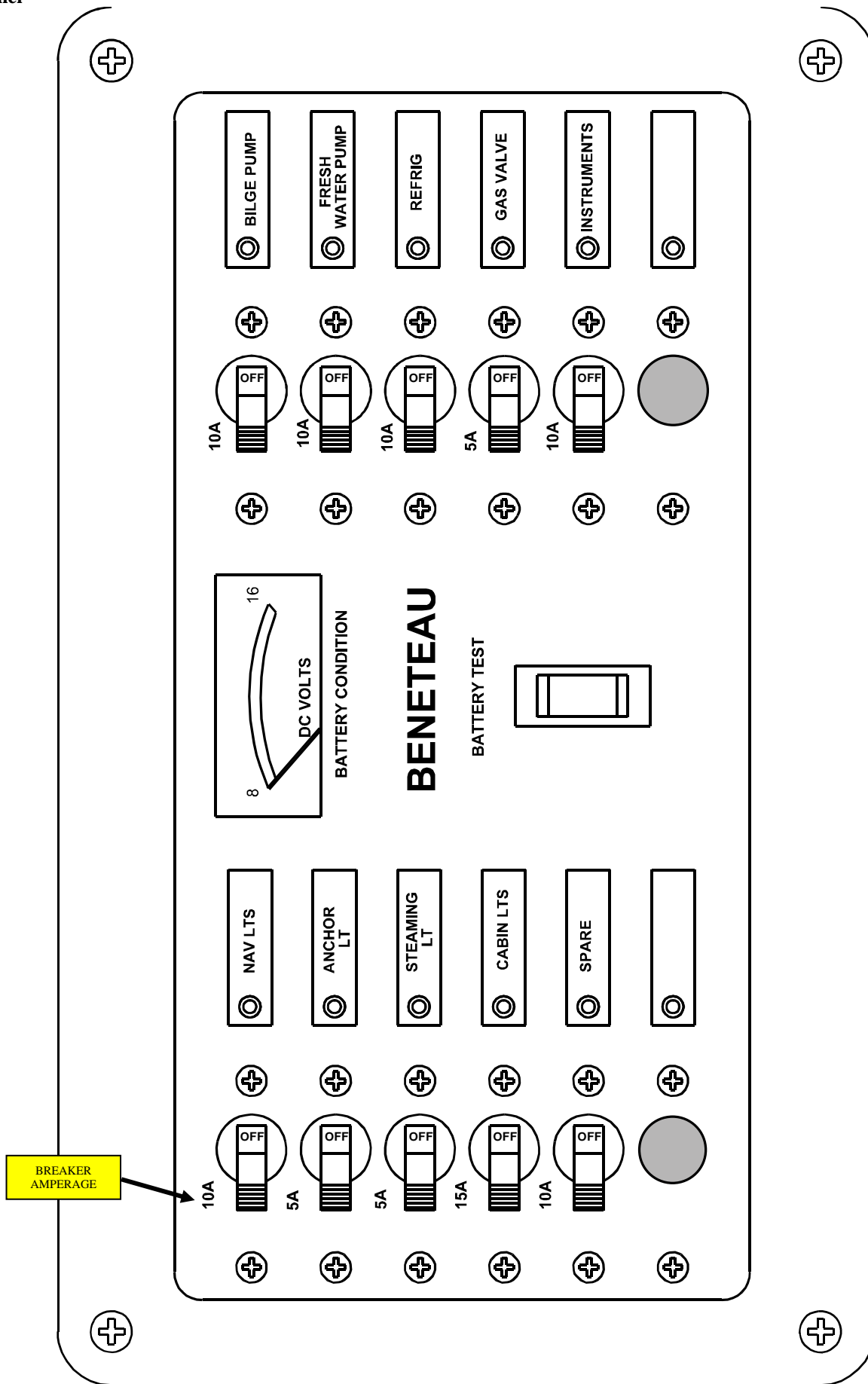

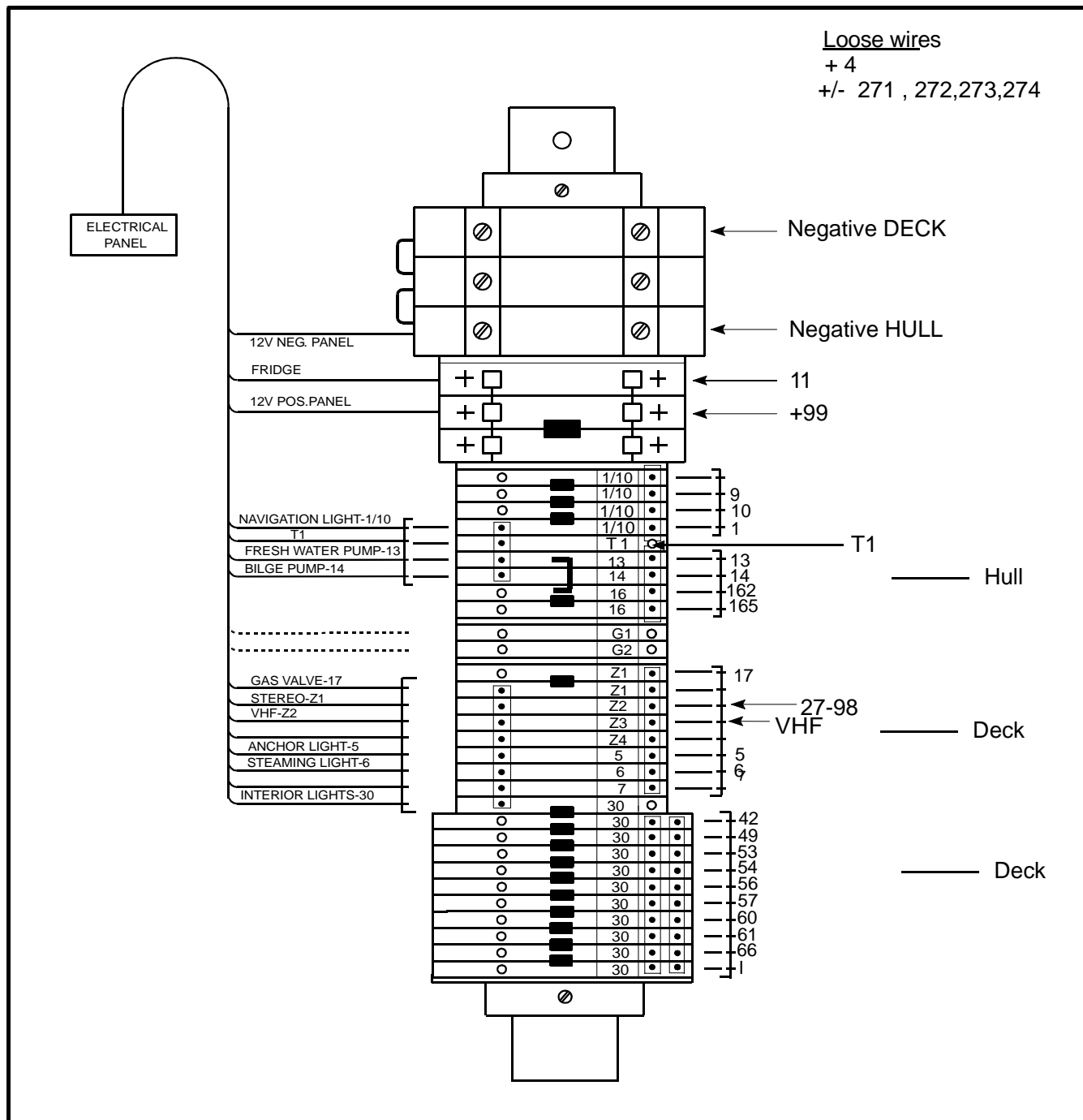

**Wago Block**

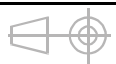

R	DESCRIPTION	DATE	DIMENSION:	Material:	VISA
	 FH8 DRAWING		TOL GEN :	DATE : 9/29/03	
			<b>B323</b> Wago block hook-up	BY : P.LG 029257	
			 <b>BENETEAU USA</b> P.O. Drawer 1218 Marion, SC 29571 (803) 423-4201	Part No:  111386	
0000			THIS DOCUMENT IS - PROPRIETARY AND REPRODUCTIONS MUST BE AUTHORIZED BY BENETEAU DRAWN BY BENETEAU - SPECIFIED AND DESIGNED BY PRODUCT MANUFACTURER.		
0000					



# 12v Harness Layouts

## Hull Harness Layout

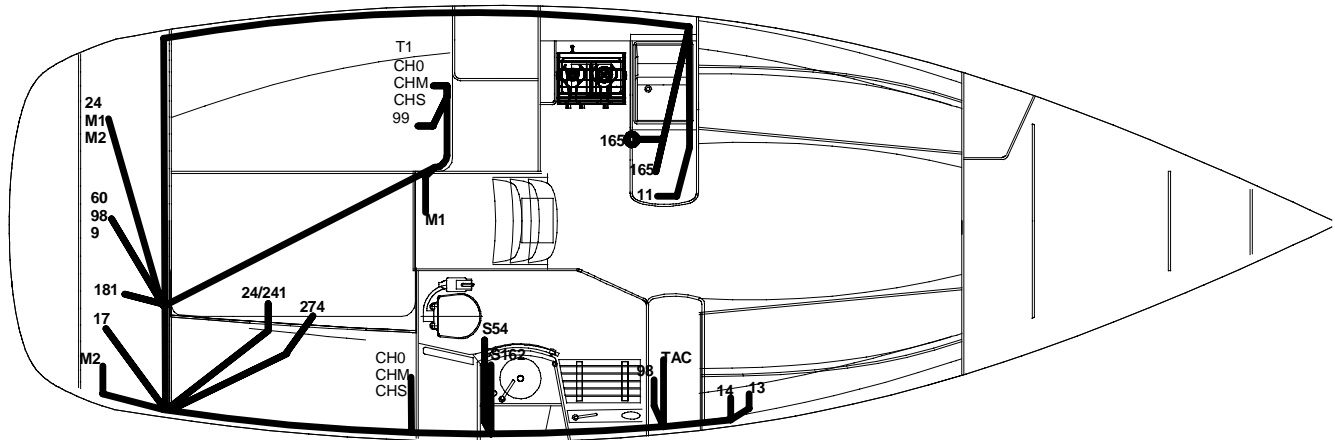

14	14x2	R/B	3.300	105° Tinned		BILGE PUMP
13	14x2	R/B	3.300			WATER PRESSURE
11	8x2	R/B	14.100			FRIDGE
18	14x1	R	6.700			12v BLOWER-Bat SW TO panel
181	14x2	R	4.300		Not by the panel	12v BLOWER-PANEL TO BLOWER
		B	3.200			
165	14x2	R	15.100			FRIDGE DRAIN PUMP
		B	13.500			
98	16x2	R/B	11.000			12V INSTRUMENTS
9	16x2	R/B	10.100			COMPASS LIGHT
54	16x2	R/R	7.200			STBD AFT BATH CEILING LIGHT
274	16x2	R/B	7.600		ot by the panel	STBD OUTSIDE SPEAKER
17	16x2	R/B	7.100			PROPANE SOLENOID
24	16x2	R/B	5.600			STBD AFT FUEL TANK -GAUGE
241	16x2	R/B	0.400			12V TO FUEL TANK GAUGE
M3	8x1	G/Y	9.500		Not by the panel	GROUNDING -AC panel to engine
M2	8x1	G/Y	4.600			GROUNDING- DECK FILLER TO TANK
M1	8x1	G/Y	3.900		Not by the panel	GROUNDING -TANK TO ENGINE
270	16X2	R/B	9.800		Not by the panel	Constant power -stereo
CHS	6x1	R	7.400		Not by the panel	BATTERY CHARGER -ENGINE
CHM	6x1	R	7.400		Not by the panel	BATTERY CHARHER -HOUSE
CH0	6x1	B	7.400		Not by the panel	BATTERY CHARGER -NEGATIVE
T1	16x1	R	9.900			ENGINE BATTERY TEST
162	14x2	R	5.800		OUT WITH 14+	SHOWER PUMP STBD HEAD
99	6x2	R/B	9.900			12V MAIN PANEL
60	14x2	R/B	9.900	105° Tinned		COCKPIT 12V OUTLET
WIRE #	SIZE AWG	COLOR	L . (m)	Code	NOTE	DESIGNATION
<b>Beneteau 323</b> HULL Harness - 2C1T						DESIGN date : 09/25/03 BY : P.L.G. B 323 B6 Page 2/3 N° : 062779
C	Add 165 sw.del 9.98 modif.		1/23/04			
B	Add 165-17 M3.270		12/17/03			
A	Add 18/181		12/03			
Ind	MODIFICATIONS		DATES			

# Deck Harness Layout

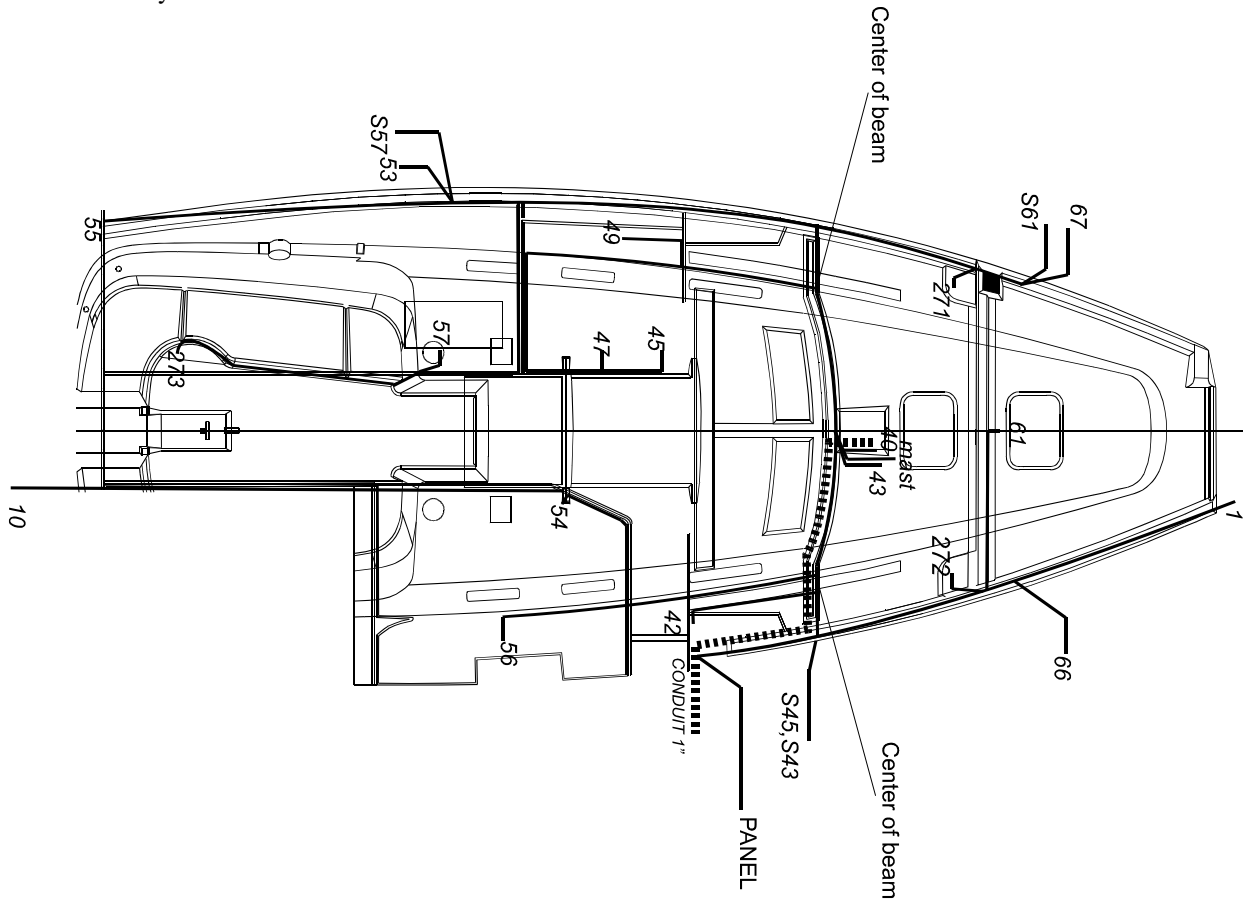

WIRE #	SIZE	AWG	COLOR	L. (m)	Code	NOTE	DESIGNATION
274	16x2	R/B	1.300	105° Tinned	Not by the panel	STBD OUTSIDE SPEAKER	
273	16x2	R/B	11.700		Not by the panel	PORT OUTSIDE SPEAKER	
270	16x1	R	0.100		Not by the panel	CST POWER RADIO MEMORY	
27	16x2	R/N	1.800		AT WAGO BLOCK	12V STEREO	
279	16x1	R	0.100		Not by the panel	POWER ANTENNA	
272	16x2	R/B	3.650		Not by the panel	STBD INTERIOR SPEAKER	
271	16x2	R/B	6.650		Not by the panel	PORT INTERIOR SPEAKER	
9	14x2	R/B	1.500			COMPASS LIGHT	
40	14x2	R	2.300			SALON CEILING LIGHT	
43	14x2	R/B	1.000		REPRIS SUR 40	SALON CEILING LIGHT	
47	14x2	R	6.800			GALLEY CEILING LIGHT	
45	14x2	R/B	1.05		Picked from 47	GALLEY CEILING LIGHT	
54	14x2	R	6.150		POS+ GO THRU CONNECTOR	BATH CEILING LIGHT	
42	16x2	R/B	3.700			CHART TABLE CEILING	
56	16x2	R/B	4.950			BATH ABOVE SINK LIGHT	
8	12x1	B	4.300			NEG.COMMON MAST	
4,5,6,7	16x2	R	4.300			MAST LIGHTS	
61	14x2	R	14.750			FWD CABIN CEILING LIGHT	
66	16x2	R/B	4.250			FWD CABIN STBD READING LIGHT	
67	16x2	R/B	8.300		Picked from 66	FWD CABIN PORT READING LIGHT	
10	14x2	R/B	10.800			STERN LIGHT	
1	14x2	R/B	5.550			BOW -RUNNING LIGHT	
49	16x2	R/B	7.000	105° Tinned		GALLEY FLUORESCENT	

DESIGN date : 09/25/03

BY : P.L.G.

**Beneteau 323**  
Deck Harness - 2C1T

**BENETEAU USA**  
P.O. Drawer 1218  
Marion, SC 29571  
(803) 423-4201

N° : 062780

WIRE #	SIZE	AWG	COLOR	L. (m)	Code	NOTE	DESIGNATION
57	14X2	R	11.300	105° tinned			PORT AFT CABIN CEILING LIGHT
53	16X1	R/B	8.600				AFT CABIN STBD READING LIGHT
55	16X1	R/B	2.400			PICKED ON 53	AFT CABIN PORT READING LIGHT
60	14X2	R/B	1.300				COCKPIT OUTLET 12V
i	14X1	R	2.800	105° tinned			12v TO SALON SWITCH
VHF	Coax	RG 8 X	4.600				VHF coax

DESIGN date : 09/25/03

BY : P.L.G.

**Beneteau 323**  
Deck Harness - 2C1T

**BENETEAU USA**  
P.O. Drawer 1218  
Marion, SC 29571  
(803) 423-4201

N° : 062780

ST40 BIDATA

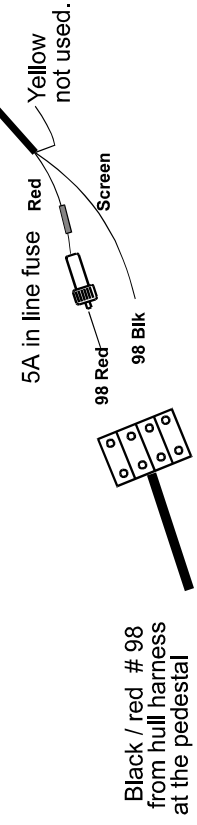
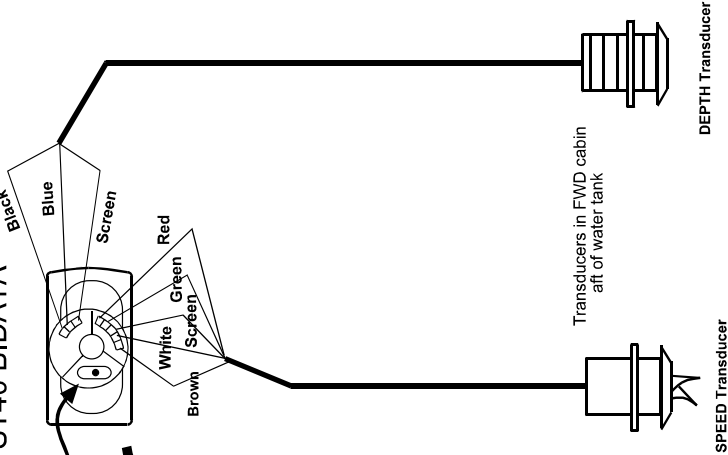
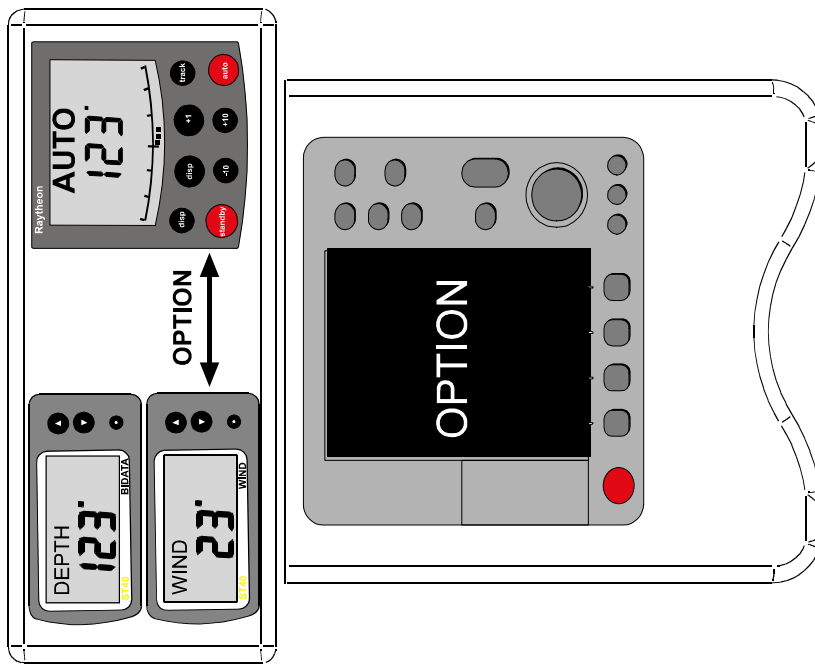

R	DESCRIPTION	DATE	Dimension :	Material: N/A
	 FH8 DRAWING		N/A	Design Date: 10/15/03
			Scale: N/A	Gen. Tol: N/A
A			<b>B323</b> ST 40 instrument installation+ wiring	
			<b>BENETEAU USA</b> P.O. Drawer 1218 Marlon, SC 29571 (803) 423-4201	
				Part No. <b>323 ST40</b>

THIS DOCUMENT IS - PROPRIETARY AND REPRODUCTIONS MUST BE AUTHORIZED BY BENETEAU - DRAWN BY BENETEAU - SPECIFIED AND DESIGNED BY PRODUCT MANUFACTURER.

## 110V-220V Electric System

The shore power system consists of a marine power cord adapter plug mounted on the transom of the boat which is connected to an 110V panel that distributes the 110V AC current to the outlets and appliances on your boat. The shore power system is rated for a maximum of 30 AMPS; care must be taken to not overload the system.

**WARNING! DO NOT WIRE OPTIONAL AIR CONDITIONERS TO THE SHORE POWER SYSTEM; INSTALL A SEPARATE SERVICE AND PANEL.**

The 110V panel consists of breaker switches which protect and turn the individual circuits on and off. The charger, hot water heater and the 110V outlet circuit are on separate breakers.

Boats are fitted with a 110V/60Hz or a 220V/50Hz system. We advise you to follow these steps in order to avoid the risk of electric shock and fire.

**Do not work on a live fitting.**

**Connect the boat / shore supply cable to the boat before you plug it into the shore supply socket with the breaker off. Turn the breaker on last.**

**Do not immerse the boat / shore cable socket.**

Turn off the shore supply switch on board before you plug in or unplug the boat / shore supply cable.

Do not tamper with the connections of the Boat / shore supply cable. Use only compatible connections.

**Never swim in a marina around boats connected to shore power. If necessary for maintenance unplug the boat being worked on and surrounding boats.**

**WARNING! DO NOT OPERATE THE 110V WATER HEATER DRY.**

### 110V Panel

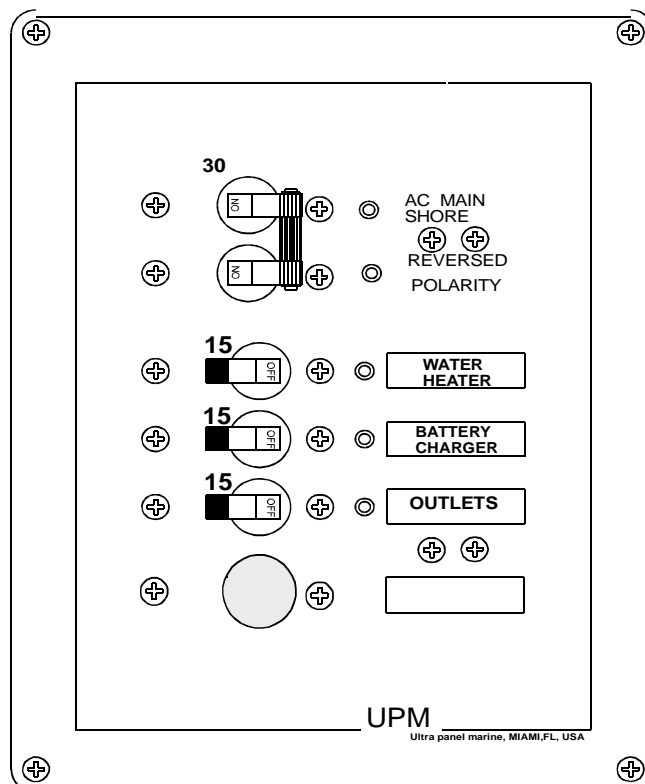

## Location of 110V Outlets and Appliances

REF	DESCRIPTION
1	Shore Power Inlet
2	Main Breaker
3	Battery Charger
4	110V Outlet
5	Water Heater
6	110V Panel

2 CABIN

3 CABIN

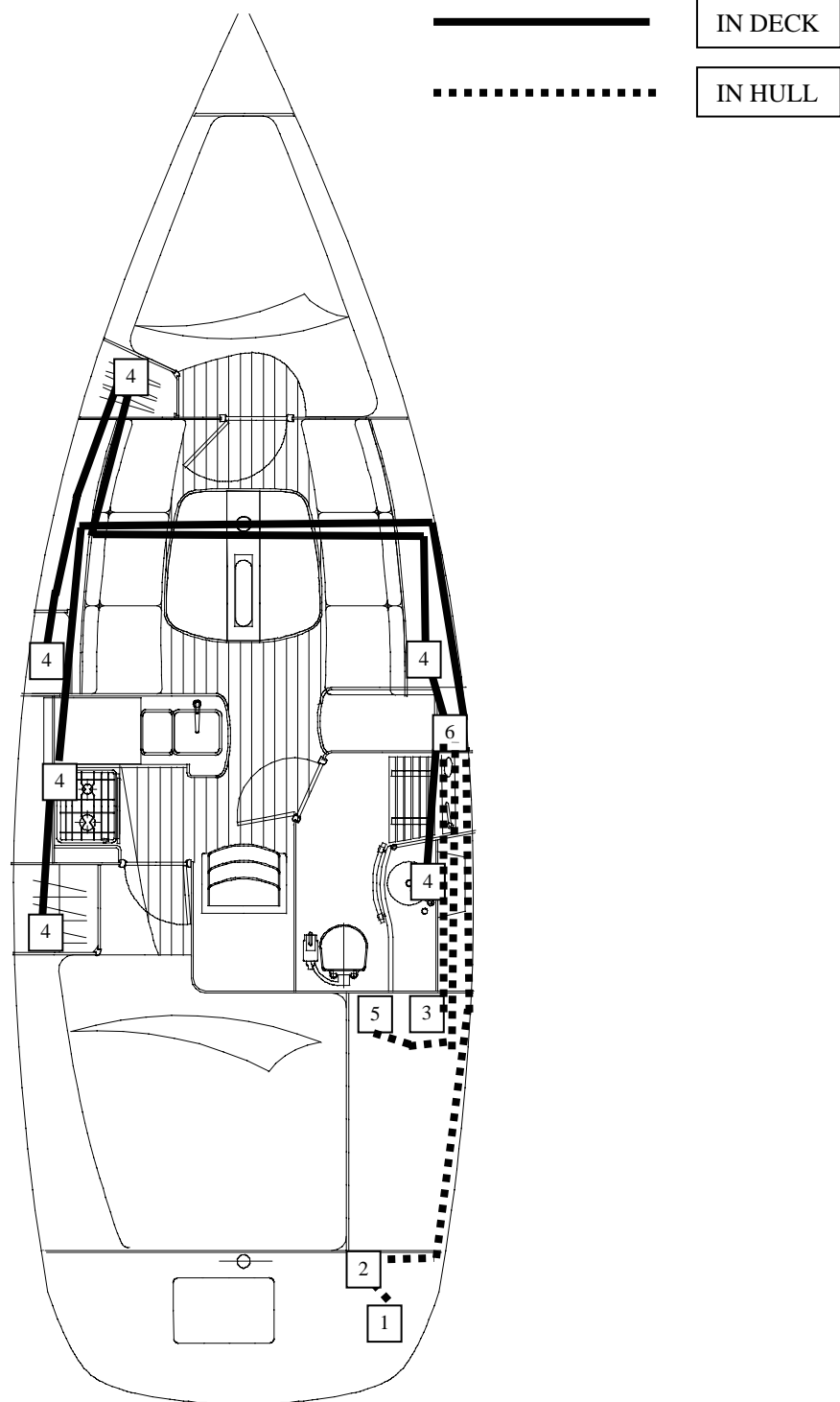

# LAY OUT OF THE CONDUITS

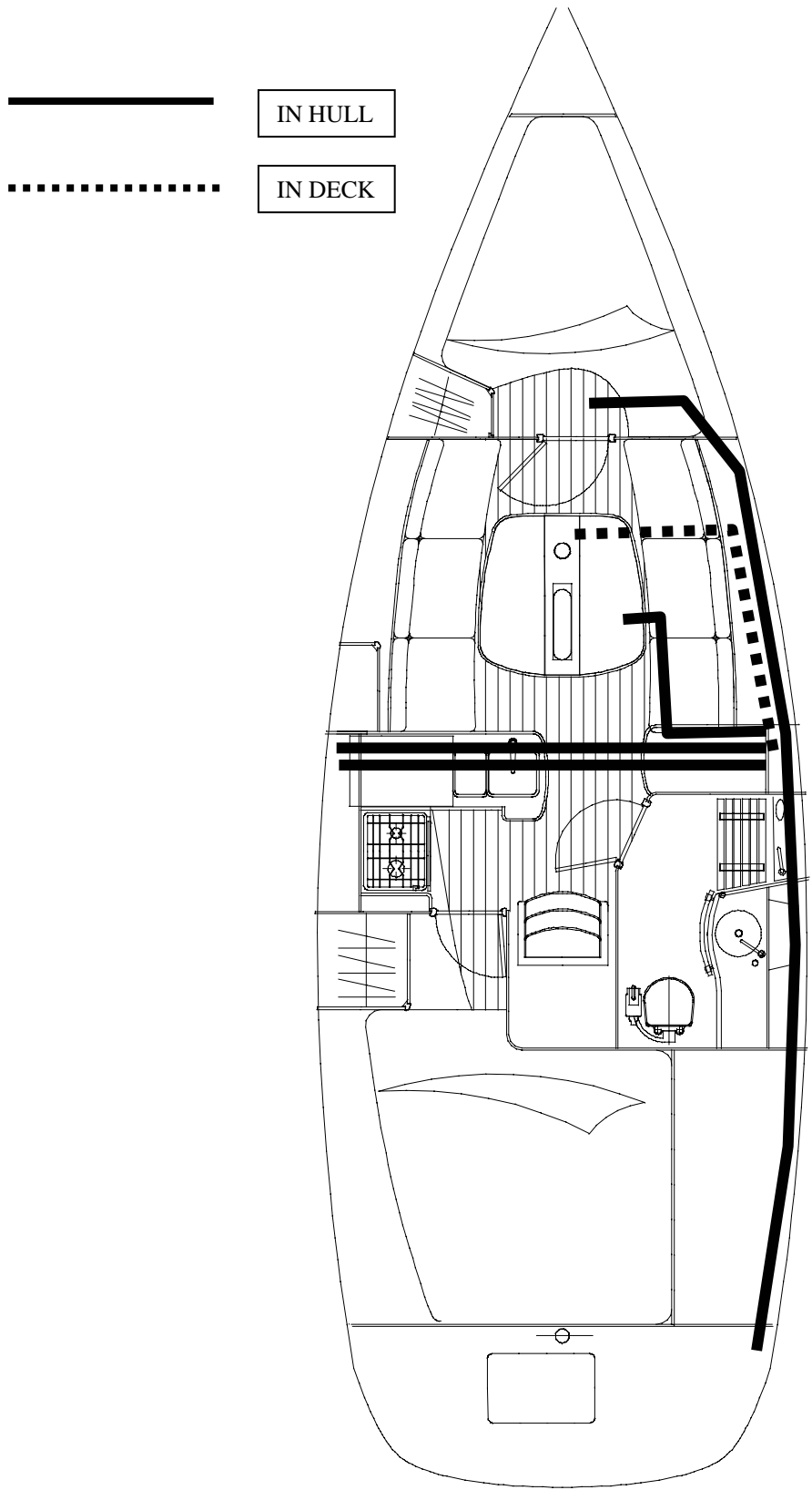

## **XX) LP GAS SYSTEM**

### **GAS STOVE**

Your Beneteau is equipped with a propane stove and oven combination. This unit is located in the galley and is gimballed for your safety and comfort in a seaway. The stove is supplied by a storage bottle located in a self draining locker in the cockpit. The pressurized gas is fed thru a regulator at the bottle which reduces the pressure and feeds the propane gas to a 12V solenoid valve. The solenoid is a remotely controlled valve which turns the flow of gas on and off from a switch located at the 12V distribution panel. A pressure gauge is located before the regulator to check the gas system for leaks.

**The boat is delivered without fire extinguishers. It is your responsibility to comply with the laws and regulations of your country (Number, capacity, type and place of fire extinguishers). We advise you to install an extinguisher less than 5 meters away from the center of each berth, less than 2 meters away from the extinguisher aperture in the engine compartment, less than 2 meters away from any open flame device and less than 1 meter away from the helm pedestal or cockpit. We advise a total capacity of the portable extinguishers reaching 8A/64B, each extinguisher having at least a 5A/34B capacity. The CO2 extinguishers shall be used to fight fires in the galley and electric fires.**

**Do not install or store flammable materials above the stove (Curtains, papers, napkins, etc...)**

**Never leave the boat unattended when the LP gas appliances are in use.**

**The appliances, which use fuel, consume the oxygen within the cabin and release combustion products into the boat. It is necessary to ventilate the boat when using the gas cooking appliances. Do not obstruct the air vents of the boat.**

**Do not smoke or use an open flame when you are trying to locate a gas leak, change the gas bottle or work on the gas system.**

**If you smell gas or find that the burners have gone out by accident, (although some appliance models cut off the gas automatically if the flames go out) turn off the gas valves and ventilate the boat in order to get rid of any residual gas. Find the cause of the problem before re-lighting the appliance.**

**Do not use cooking appliances to heat the inside of the boat.**

**Turn off the 12V solenoid and the valve on the cylinder when you do not use the appliances.**

Do not obstruct the access to the gas system components, in particular the access to the valves (cylinders and gas cooker).

The flexible hoses, which connect the gas cylinder at one end of the system and the stove at the other end, shall be changed in pursuance of the regulations in force in your country. Only use hoses, which meet the safety standards of your country.

Do not use the gas cylinder storage space to store other equipment.

Pay particular attention to keep in good condition the screw thread of the cylinder on which the regulator is attached. Check the condition of the regulator every year and change it if necessary. Use a regulator identical to the one which is fitted.

Make sure that the valve of the empty cylinder is turned off and disconnected from the system.

Do not use ammonia-based products to clean any part of the system or to discover a leak.

**The LP gas system should be checked for leaks on a regular basis. See the manual provided with the stove for instructions.**

## OPERATION

**WARNING! ALWAYS LEAVE BOTH THE SOLENOID VALVE AND THE VALVE ON THE GAS BOTTLE CLOSED WHEN THE STOVE IS NOT BEING USED.**

1. Read and follow the instructions printed on the propane warning labels located at the appliance and under the lid of the gas storage locker.
2. Be sure all burner and oven knobs are in the off position before attempting to operate the galley stove.
3. Activate the main 12V system and be sure the solenoid switch is in the off position.
4. Open the supply valves and test the system for leaks following the instructions on the locker warning label.
5. Switch on the solenoid using the breaker on the 12V panel.
6. Light the appliance in accordance with the stove manufactures procedures. Generally each burner is lit by turning the burner control knob to the lighting position and then pushing the knob in. A safety thermocouple will keep the valve open as long as the burner remains lit. If the flame goes out it will stop the gas flow to the burner.

**Note: If the odor of gas is detected at any, time turn off all electrical and mechanical systems, extinguish any open flames and immediately check for a propane leak. Propane is a heavy gas and may settle in the bilge which represents an explosion and fire hazard.**



# LAY OUT OF THE GAS SYSTEM

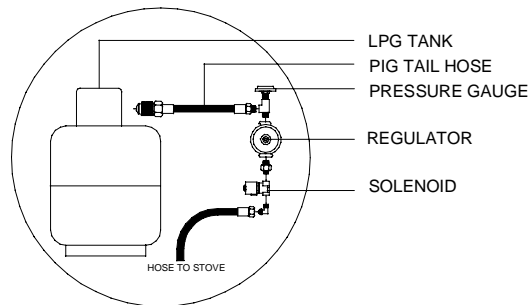
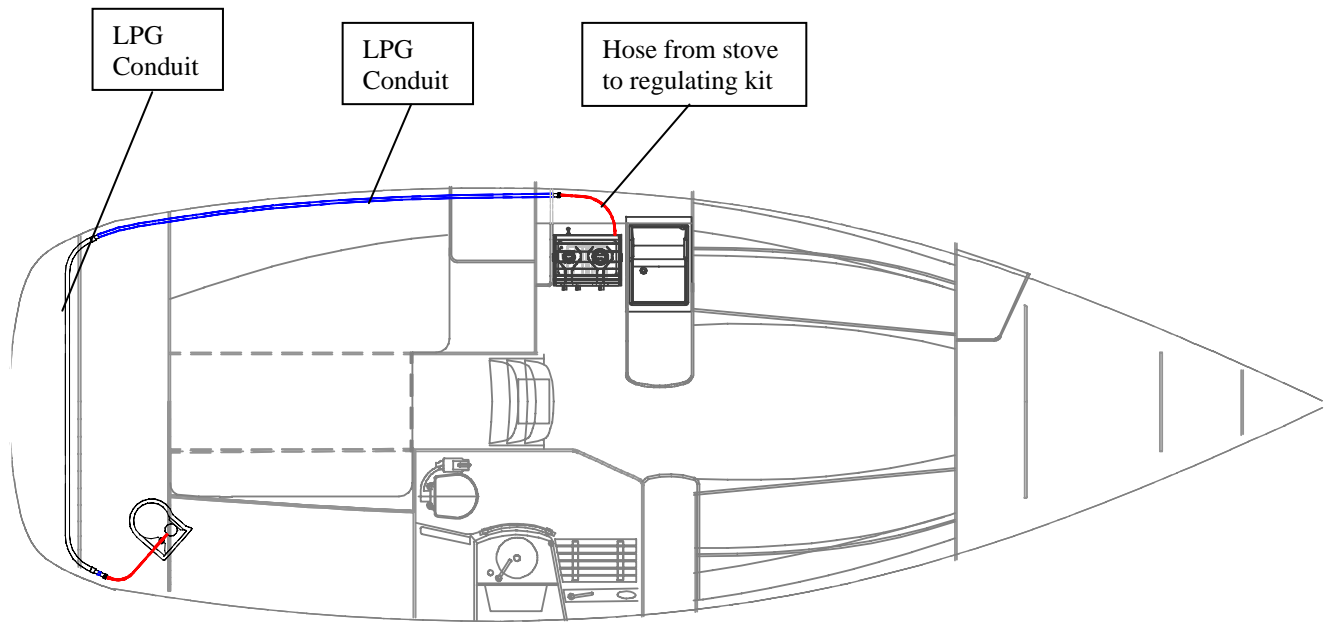

PROPANE LOCKER REGULATING KIT AND LPG TANK

## XXI) STEERING SYSTEM

### WHEEL STEERING

Wheel steering has become increasingly popular over the years in lieu of a tiller. Reasons for this preference include more cockpit space, and ease of steering over a long cruise.

A typical wheel steering system remotely turns the rudder on your boat using a quadrant bolted to the rudder post and connected to the wheel through a chain and cable system. A stop assembly allows approximately 90 degrees of travel, and prevents rudder over-travel which could damage the cable and chain assemblies.

#### Wheel Steering Operation

Wheel steering requires use in order to obtain familiarity with it. A feel for your boat will develop and a sensitivity to conditions will increase your control.

**NOTE:** When backing under auxiliary power in reverse gear, it is necessary to maintain a hold on the steering wheel the entire time. The rudder and steering wheel have a tendency to rotate with force if left unattended while backing. This is due to the normally large area aft of the rudder post becoming the forward area, thus creating an imbalance.

The rudder stop system is designed to produce a positive stop to prevent over-turning the mechanisms of the steering system. It is not designed to absorb the potentially tremendous load of a rudder turning freely while backing. INSPECT the rudder stops on a regular basis to ensure they limit rudder travel to the correct amount; failure to limit rudder play may result in steering failure!

**CAUTION! ALLOWING THE RUDDER AND WHEEL TO SPIN OUT OF CONTROL WHEN BACKING MAY CAUSE SERIOUS DAMAGE TO THE STEERING SYSTEM, POSSIBLY RESULTING IN A DANGEROUS LOSS OF STEERING CONTROL.**

When leaving the boat at a mooring or slip, make sure the wheel brake is properly tightened. Do not allow the system to free wheel when not in use as excessive wear or damage may result.

**WARNING! DURING OPERATION THE PIVOTING STEERING UNIT SHOULD BE LOCKED INTO ITS NORMAL OPERATING POSITION WITH THE STEERING WHEEL PERPENDICULAR BOW TO STERN. DO NOT OPERATE VESSEL WITH THE STEERING UNIT PIVOTED OUT OF THE NORMAL OPERATING POSITION.**

#### Emergency Tiller

As a safety precaution on your Beneteau, an emergency tiller has been provided as a backup to the wheel steering system.

**NOTE: PRACTICE USING THE EMERGENCY TILLER AND BE SURE ALL CREW MEMBERS KNOW THE LOCATION AND OPERATION OF THE EMERGENCY TILLER**

Check at least once a year that the steering cables are properly tightened and lubricated.

To use the emergency tiller, remove the cover over the rudder stock by using a winch handle; insert the tiller into the socket on the rudderstock. You may remove the steering wheel while using the tiller, to improve the tiller handle clearance.

# STEERING SYSTEM LAYOUT

REF	DESCRIPTION	REF	DESCRIPTION
1	Rudder	9	Cap Over Rudder Stock
2	Spacer Ring	10	Steering Cable
3	Lower Rudder Shaft Bearing	11	Idler Sheave Box
4	Rudder Tube	12	Steering Chain
5	Upper Rudder Shaft Bearing	13	Steerer
6	Retaining Ring	14	Wheel Brake
7	Quadrant	15	Steering Wheel
8	Rudder stop	16	Emergency Tiller

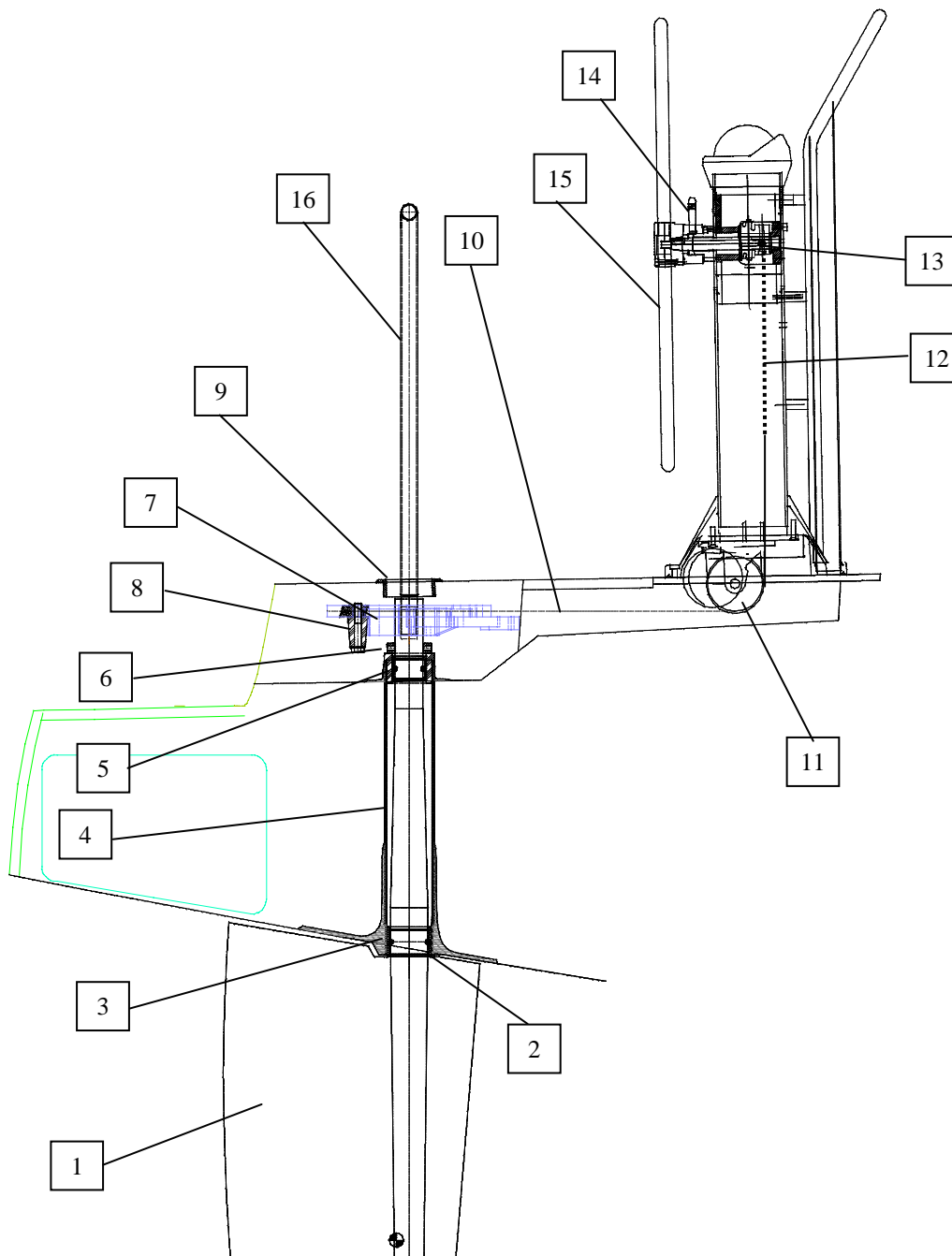

## XXII ENGINE

### CUTLASS BEARING

The cutlass bearing is a water-lubricated rubber bearing that the prop shaft rotates in. It is critical for the shaft to be perfectly aligned through the bearing and mated to the engine coupling to prevent premature wearing of the cutlass bearing.

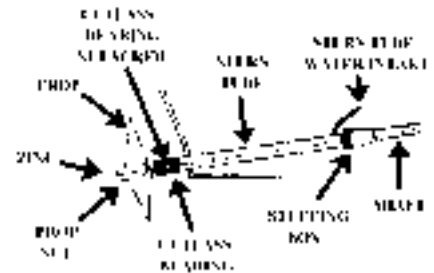

### STUFFING BOX

The stuffing box is a rubber seal around the prop shaft, which allows the shaft to exit the hull and keep water out. Water is forced into the stuffing box via a thru hull and vent tube for lubrication. Once a year or every 200-engine hours grease the seal at "D" with 1cm<sup>3</sup> of grease. The seal should be replaced every 500 engine hours or every 5 years. See the manufacturer's directions for more details.



### DIESEL OPERATION

Operation of the diesel engine includes preparation for starting, running, stopping, and securing the power system after use. The following paragraphs are a general guide, with complete procedures being more thoroughly covered in the engine manual.

### ADDITIONAL CONTROLS

In addition to the control panel the following controls are associated with engine operation.

1. Battery Switch - Although a part of the electrical system, this switch must be energized in the ON position to provide power to the engine starter motor.

**DO NOT OPERATE BATTERY SWITCHES WHEN THE MOTOR IS RUNNING!**

2. Throttle and gearshift controls are located at the helm station.
3. Engine Stop Handle or Solenoid switch.

### RUNNING THE ENGINE

#### Before Starting the Engine

**Before you start the engine, make sure that the engine compartment bilge is clean and dry. If there is the slightest presence of fuel in the engine compartment, you must not start the engine.**

1. Open the raw water intake thru hull valve.
2. Check to be sure the fuel shut-off valve is open.
3. Check the coolant level if the engine is fitted with a closed heat exchanger cooling system.
4. Check the oil in the sump and gearbox (this should be repeated after a few hours running).
5. Check the tension of the alternator drive belt.
6. Move the lever to neutral, and open the throttle a little (the mechanism will differ depending on the control box fitted).
7. Turn on the black negative battery handle and the red handled engine battery switch.

## Starting the Engine

Insert the ignition key and turn it to "ON" (and then to the intermediate preheat position if your boat's engine has this system). A warning alarm will sound as you start up - the engine manual explains the meaning of this alarm and its operation.

Press the starter button or turn the key, as appropriate, and release the button or key, as soon as the engine is running **CHECK THE ENGINE EXHAUST FOR COOLING WATER DISCHARGE, IMMEDIATELY STOP THE ENGINE AND CHECK THE RAW WATER SYSTEM. IF NO COOLING WATER IS DISCHARGED FROM THE EXHAUST.** Let the engine run for a moment, and then bring the throttle lever back to the idle position. After you engage the clutch, increase the engine speed very gradually (it should take at least five minutes to reach cruising speed), because a diesel engine will warm up only when it is under load.

Do not operate the starter for more than 10 seconds at a time. If the engine does not start, wait at least 30 seconds before trying again.

**CAUTION! OVER CRANKING AN ENGINE WITH A WATER LIFT MUFFLER CAN CAUSE DAMAGE! IF THE ENGINE DOES NOT START, CLOSE THE THRU HULL AND SEEK ASSISTANCE.**

Once engine has started, check that the warning lights for oil and coolant pressure have gone out, and that the batteries are charging properly.

Check that the coolant water is circulating correctly, water should be either venting through the exhaust or passing through the heat-exchanger return circuit, depending on the cooling system fitted.

**CAUTION! NEVER OPERATE THE BATTERY CIRCUIT SWITCH OR THE IGNITION KEY WHEN THE ENGINE IS RUNNING. THE RESULTING CURRENT SURGE WILL DAMAGE THE ALTERNATOR DIODES.**

Engage the clutch firmly but not harshly. Do not rev the engine hard. When shifting from forward to reverse, or vice versa, the lever should be held in the neutral position for a moment before proceeding. Shifting should be performed with RPM reduced to idle. Keep a regular watch to make sure that the coolant water is circulating properly.

## Stopping the Engine

To stop the engine:

1. Place throttle/transmission lever in the idle/neutral position.
2. Let engine idle for one (1) minute to allow it to cool down.
3. Engage the engine kill button or handle until the engine stops.
4. Turn the key to the "OFF" position.

**CAUTION! DO NOT SWITCH BATTERY SELECTOR UNTIL THE ENGINE HAS COME TO A COMPLETE STOP! THIS WILL PREVENT ALTERNATOR DIODE DAMAGE.**

**CAUTION! IF YOU CLOSE THE FUEL AND SEA WATER VALVES AFTER STOPPING THE ENGINE, BE SURE TO RE-OPEN THEM BEFORE RESTARTING. FAILURE TO DO SO COULD CAUSE ENGINE TO OVER-HEAT AND CAUSE DAMAGE TO THE PUMP IMPELLER OR CAUSE FUEL LINES TO BECOME AIR LOCKED**

## FUELING

While employment of a diesel engine results in a greatly reduced fire hazard when compared to gasoline, it should be remembered that diesel fuel is flammable, and that the employment of good fueling practices are necessary. The following steps are provided as guidelines.

## Before Fueling

1. Extinguish all smoking materials and check the fueling area for other sources of spark or flame. Remove if found.
2. Shut off the engine and the electrical generator if one is aboard.
3. De-energize all electrical equipment.
4. Close all hatches and ports.
5. Ensure that a fire extinguisher is readily available.
6. Ensure that the proper (diesel, not gasoline) hose is about to be used.

**WARNING! DO NOT FUEL DURING AN ELECTRICAL STORM. BESIDES THE OBVIOUS HAZARD OF LIGHTNING, THE POSSIBILITY OF STATIC DISCHARGE IS GREATLY INCREASED AT THE TIME.**

## Fueling

The diesel tank is filled thru a deck filler. (SEE DECK SECTION FOR FUEL DECK FILL LOCATION)  
The tank is filled for the first time with the cock closed to calibrate the fuel gauge. During filling, put a funnel with a filter in the deck filler hole, and watch the fuel overflow outlet. Useful tip: to avoid staining teak on the deck with diesel oil, wash the deck with water beforehand, this will stop the oil from penetrating the wood. While filling, note how much fuel corresponds to the markings on the gauge (remembering that a small amount of fuel not consumed during the factory engine tests may remain in the tanks);

Gauge markings:                      1/4    1/2    3/4    F

Note: ( number of gallons per mark)    \_\_\_\_\_

Always sail with your tanks as full as possible, both to avoid any contamination of the diesel oil with water (due to condensation in the tank), and to prevent the injector pump running dry and needing re-priming.

**Fuel that is stored outside the tanks (spare cans, jerrycans) should be kept and stored in a ventilated place.**

**Know exactly where the fire extinguisher aperture is located so you will be able to put out a fire breaking out in the engine compartment.**

## After Fueling

Replace cover, clean up any spilled fuel. If any rags, etc. were used for this purpose, dispose of them ashore.

Check below decks for presence of fumes or fuel leakage. Check bilge, engine space, and main cabin.

**WARNING! IF FUMES OR EVIDENCE OF LEAKAGE IS FOUND, DETERMINE THE CAUSE, CORRECT IT, AND CLEAN UP ANY SPILLAGE BEFORE PROCEEDING.**

Open all hatches and ports to ventilate the boat.

Switch on battery.

The engine should be started only when it is certain that no potentially hazardous condition exists.

## Fuel Sanitation

The fact that a diesel engine does not require an ignition system can, and usually does, result in an engine that is far superior to a gasoline engine with regard to dependability. Whether this is actually the case depends greatly on cleanliness of the fuel that is supplied to the engine since the close tolerances required by the engine's fuel delivery system make it extremely intolerant of any form of dirt or water contamination. The engine is supplied with filters that prevent contaminants from reaching the engine where they could cause damage, but a clogged filter, although providing this protection, can also stop an engine. Keeping the filters free of dirt and water is an obvious answer to this problem, and the cleaning schedules set forth in the engine manual will in most cases keep filters clean enough to prevent stoppage.

## **Bacterial Contamination**

A factor that can cause additional problems is bacterial contamination of the diesel fuel. The bacteria involved need both water and fuel to exist, and if present, will thrive in a fuel tank. As they multiply, they form a filter-choking brown slime. Often their presence will not be known until rough weather churns up the fuel tank causing clogged filters at a most inopportune time.

Keeping water out of the fuel will, of course, prevent the problem entirely, and while every effort should be made towards this, such as obtaining fuel from reputable dealers, it must be remembered that a certain amount of water due to normal condensation in the tank is to be expected.

## **Fuel Additives**

Fuel additives or conditioners provide means of combating this problem. These additives break the water down to a molecular level, dispersing it throughout the fuel and allowing it to pass harmlessly through the fuel system. Various brands of this product are available at marine supply stores. As with all products of this nature, the directions on the container should be carefully followed.

# ENGINE LAY OUT

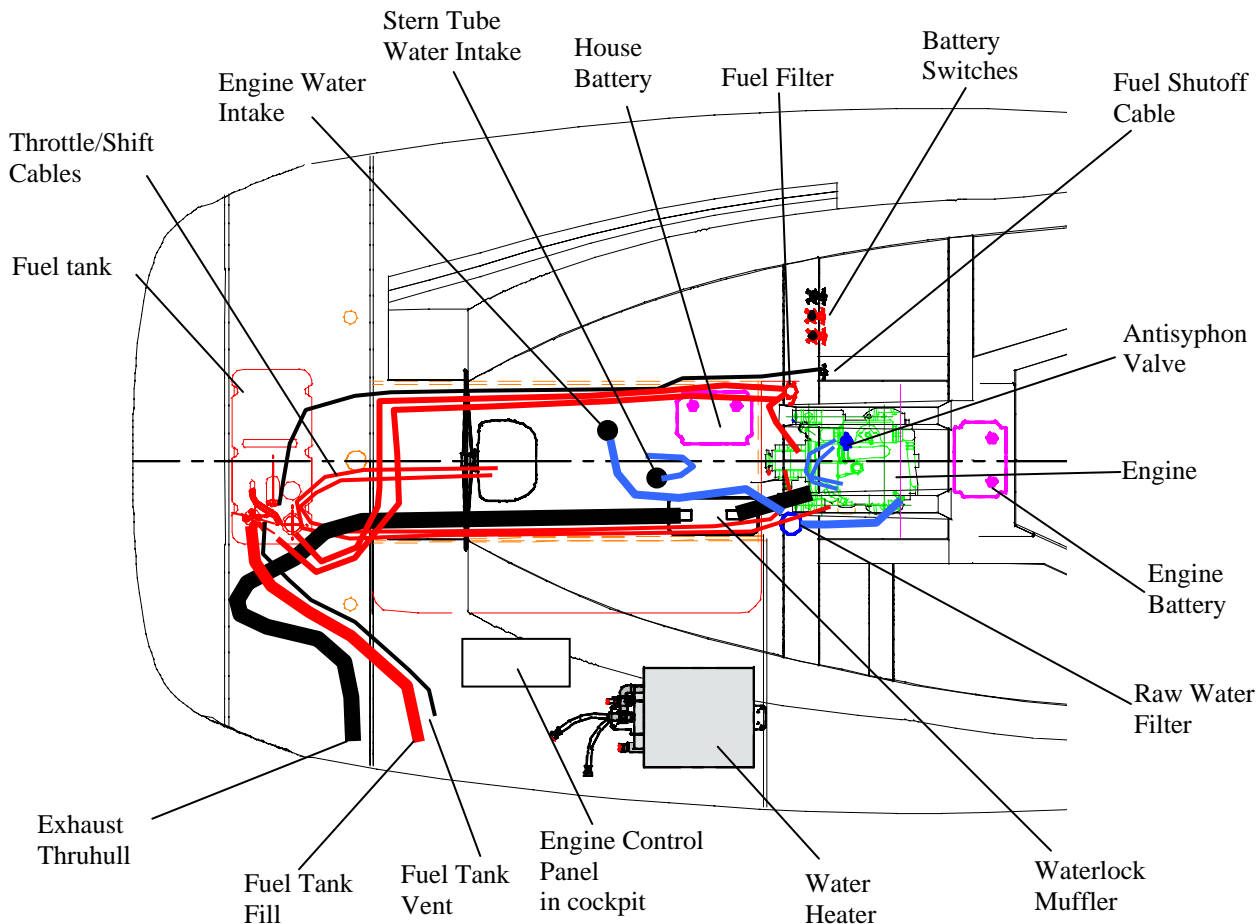
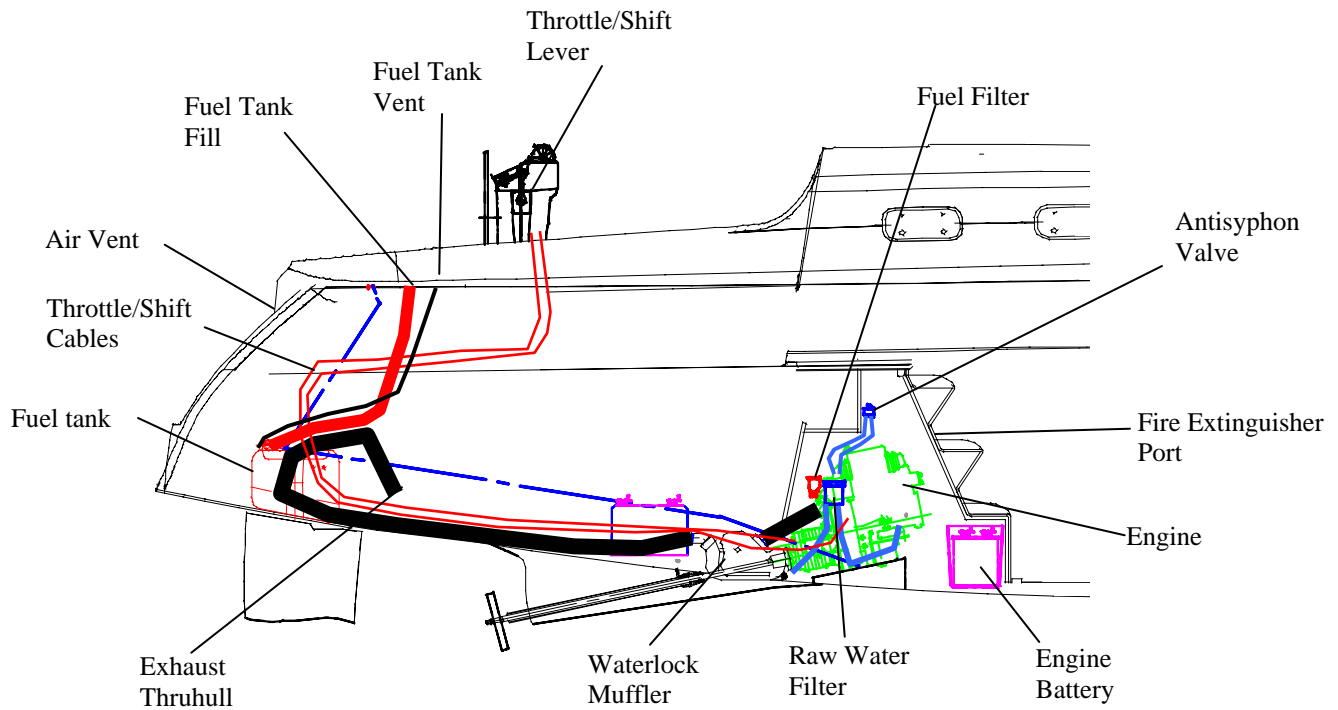



## XXIII) HANDLING

Contact your BENETEAU dealer for maintenance and repair of your boat. The dealer will advise properly, or will supply you with the spare parts you need or the materials that are suited to your boat.

Have your boat hauled & serviced once a year.

POSITION OF LIFTING STRAPS AND CRADLE POSITION.

**NOTE:** POSITION DIMENSION IS FROM CENTER STANCHION

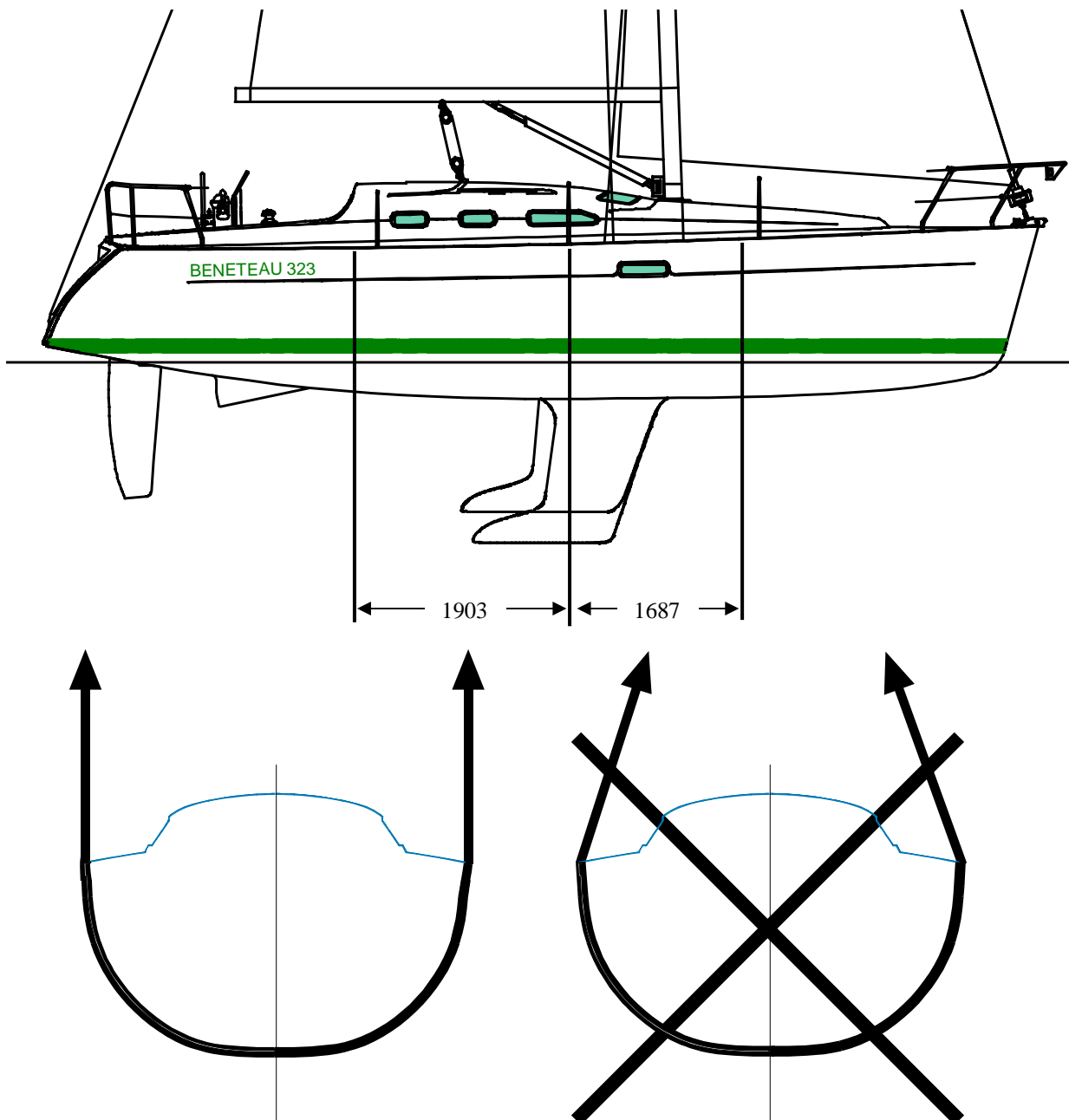

## **XXIV) MAINTENANCE OF YOUR BOAT**

Your boat represents a sizable capital investment that needs special and regular care. Safeguarding your investment and looking after your own safety should persuade you of the importance of careful and regular upkeep of your boat. The maintenance suggestions in the following sections will help you with the basics. Always refer to the original manufacturer's manual for specific guidelines on individual components.

**NOTE: It is important to clean the bottom of your boat at least two or three times a year.**

### **General Hull Maintenance**

- **DO NOT SAND THE HULL WITH COARSE SANDPAPER.**
- **DO NOT USE SOLVENTS TO CLEAN HULL.**
- **DO NOT WASH WITH PRESSURE MACHINE USING WATER WARMER THAN 95 DEGREES F. (35 degrees C.).**
- **DO NOT USE PRESSURE EXCESS OF 2175 PSI (150 BAR.) WHEN USING A HIGH PRESSURE SPRAY WASH.**
- **DO NOT HOLD NOZZLE CLOSER THAN 4 INCHES (10 CM) TO SURFACE OF HULL.**
- **DO NOT MACHINE SAND.**

We believe the above points to be pertinent for all FRP boats.

## **GEL COAT**

The gel-coat is vulnerable to any nicks and scratches it may get during maneuvering in harbor and on a mooring. The best way to avoid them is to undertake maneuvering calmly, after thinking out all the relevant factors (such as speed, current, wind, and the layout of the harbor). Always have one of the crew ready to put out a fender at the right place. When bringing in the anchor chain, back off or swing the boat round so as not to rub the chain against the hull. Hold the anchor well clear as you bring it aboard so that it does not scrape the stem: lay it on deck and lash it down at once, if only temporarily.

Never use dirty fenders.

Hose off the hull and deck as often as possible, with fresh water.

Before hosing down, remember to check that the hatch covers are closed; and it is wise not to take on diesel oil or fresh water supplies while you are hosing off the hull.

After a few years, the gel coat may be re-polished, either with a lambs wool buffer and polish, or by hand using a polish or similar product. Your yard will also be able to supply you with special cleaning products for getting rid of stubborn stains.

## MINOR GEL COAT REPAIRS

To fill in a scratch or small nick, order a **Beneteau Gel coat Repair Kit** with instructions for use, from your dealer or obtain a small quantity of gel coat and catalyst.

Clean the affected area and rub it down with wet-and-dry sandpaper, then dry it off thoroughly (use a hair-dryer if necessary). Mix the components of the gel coat, and fill the scratch using a spatula avoiding any excess; cover with a sheet of cellophane. Once hardened remove cellophane and rub down with very fine wet/dry sandpaper (grade 600 or 800), and finish off by polishing the new surface.

## THE DECK AND DECK FITTINGS

Using a gentle liquid detergent, scrub all nonskid areas to keep them free of dirt.

Light-alloy sections (tracks, etc.) can be cleaned in the same manner.

The tiny spots of oxidation pitting that may appear on stainless steel parts are nothing to worry about. Polishing will remove them.

From time to time, lubricate pulley blocks and sheaves, turnbuckles, tracks and travelers with light grease or a water-repellent lubricant such as WD-40 or Triflow.

After a certain time at sea, your winches will need cleaning inside. They must be cleaned out completely once a year. Follow the manufacturer's instructions carefully.

When dismantling deck fittings, have a bowl close at hand for putting the parts in, and circle the area with a rolled dishcloth, or the like, so that any screws or springs you drop do not roll overboard. Use the lubricant recommended by the manufacturer before reassembling.

**Warning! Incorrect re-assembly can cause accidents. Note the order in which parts are dismantled, which will make it easier to put them together again later.**

Acrylic plastic hatch covers and portholes should be rinsed off with fresh water and rubbed over with a soft cloth soaked in liquid paraffin.

## THE RUDDER

Once a year, check steering gear. If necessary renew any parts (bushings, glands, etc.) that are worn. Lubricate the steering chain and cable and or gears.

Never lubricate Nylon, Ertalon or Teflon bushings, with either oil or grease, use only WD-40.

If you have wheel steering, maintenance should be in accordance with the manufacturer's recommendations.

Make regular checks on all the clamps, the condition of the quadrant, the cables or push rods, guide sheaves and the chain in the column to the wheel.

Make regular checks of the steering end stops to ensure they are adequately stopping the rotation of the rudder, this is important for direct drive push rod systems. Over rotation of the rudder could cause a steering lock up.

## INTERIOR WOOD

Repairs to interior varnished surfaces are very challenging to accomplish. They should be attempted by skilled professionals.

The internal woodwork used in most of our boats is varnished. This should be regularly rinsed off with fresh water and a little liquid detergent, then polished with a chamois leather.

Should the woodwork become damaged, gently rub it down with very fine sandpaper and touch it with several coats of the varnish. Your dealer should be able to order a Beneteau touch up kit. When this is dry, rub it down with a very fine wet-and-dry sandpaper (grade 800 or 1000) and finish off with polish (or a silicone spray) or wax.

## ELECTRICAL SYSTEMS

It is essential for an electrical system to have a battery in sound condition to function properly. The following are some of the things to maintain a battery in the best condition.

- Keep the battery clean and the terminal posts well greased.
- Keep the battery electrolyte checked regularly
- Keep the battery fully charged.

If you have to leave your boat unused for more than a month it is best to leave your batteries with your yard so that they can be kept charged. Keep a suitable charger onboard so you can recharge your batteries at dockside without having to turn on the engine.

If you have an inboard engine, check the condition and tension of the alternator drive belt. From time to time, spray a little WD-40 or something similar on all the connections to the control panel, terminal boxes and lamp sockets. Make sure that cable grommets are watertight; smear them with Vaseline so that they do not dry out and deteriorate.

## BATTERY MAINTENANCE

Make sure that the level of the electrolyte is always at least 1/2" above the top of the plates. This level can change suddenly, due to evaporation in an overheated bilge.

**WARNING! THE ELECTROLYTE IN A BATTERY IS A SOLUTION OF SULFURIC ACID. IF ANY SHOULD ENTER THE EYES, RINSE IMMEDIATELY WITH LARGE AMOUNTS OF FRESH WATER, AND SEEK MEDICAL ATTENTION. ELECTROLYTE SPILLED ON SKIN SHOULD BE RINSED WELL WITH FRESH WATER. EVEN SMALL AMOUNTS OF ELECTROLYTE SPILLED ON CLOTHING WILL DESTROY THE CLOTHING.**

If the level is low, fill the battery with distilled water and nothing else. The level of acidity (i.e. the relative density of the electrolyte) should also be checked from time to time.

**CAUTION! USE ONLY PURE DISTILLED WATER TO REPLENISH ELECTROLYTE LEVELS. THE WATER FROM MANY CITY WATER SUPPLY SYSTEMS IS UNSATISFACTORY FOR BATTERY USE.**

Keep battery connections clean and tight. A cup full of strong baking soda solution and a toothbrush will clean corrosion from the terminals and neutralize any spilled acid (do not allow any of the solution to enter the battery cells). A coating of petroleum jelly or silicone grease on the battery terminals will inhibit corrosion.

## WATER SYSTEM

Check all joints regularly for leaks. Keep the tank(s) filled. If, however, you have to leave the boat unattended for several months, disconnect the water lines, purge them, and rinse them thoroughly with vinegar and water so that they do not form foul-smelling deposits.

**Important:** If the electric pump continues running when all the taps are closed, switch off the power supply at once and check the water system to find and overcome the leak that is causing this.

Check the thru-hulls, seacocks, connectors and hose clamps regularly. Make sure the seacocks turn freely.

## MARINE HEAD

Maintenance consists of regularly pumping the system out with fresh water and leaving the holding tank empty whenever possible.

Check the thru-hulls, seacocks, connectors and hose clamps regularly. Make sure the seacocks turn freely.

## ENGINE

Whether maintenance of the power system is to be performed by the owner or delegated to a mechanic, it is the owner who must first initiate any action that is to take place. He must either perform the maintenance or decide to call someone to do the job. A working knowledge of the power system is essential in the first case, and preventive maintenance desirable in the second. The engine manual is, of course, the prime source for engine information and should be consulted, preferably before the fact. The following paragraphs are included as a supplement to cover any required maintenance procedures that are not a part of the engine manual.

We have already stressed the points that are of importance for an engine to keep working properly. It might be added that the engine compartment should be kept scrupulously clean; check for any unusual oil or fuel leaks. Inspect all the electrical connections frequently.

Drain the bowl of the fuel/water separator at regular intervals to lessen the chance of water damage to your engine's fuel system. Keep fuel tanks filled.

Inspect the engine mounts and coupling for loose bolts regularly.

Check the oil and coolant levels everyday.

Check the alternator belt for the correct tension, keep a spare belt on hand.

Check all hoses and fuel lines for leaks regularly.

**NOTE:** Always have a spare set of sacrificial anodes on board, and regularly check those that are already fitted for deterioration; they should be replaced when their size has been reduced by half. The time this takes will vary with the waters in which the boat is used. Water temperature, salinity, the presence of neighboring boats, the nature of the bottom and the materials in the dock will all affect the life of your boat's anodes.

Order your spare anodes thru your dealer or from Beneteau Customer Service.

### **CALIFORNIA**

#### **Proposition 65 Warning**

Diesel engine exhaust and some of its constituents are known to the State of California to cause cancer, birth defects, and other reproductive harm.

## SAILS

Check the sails regularly, as the slightest wear in the stitching or at a reinforced part can very quickly have dramatic consequences. Keep a small sail repair kit on board and a book showing how to carry out minor work yourself until you can get the job done by a professional sail maker.

Keep a special eye on points where the sails can chafe on the rigging or fittings - turnbuckles, lifelines, shrouds, spreaders, etc.

Salt water and sunshine take their toll on sails. Whenever possible, rinse the sails in fresh water and leave them stretched out (preferably on a lawn) to dry. Never dry a sail by hoisting it and letting it flog in the wind; this will very quickly cause the sail to deteriorate. Never fold and store a damp sail.

## **XXV) WINTERIZING PROCEDURES**

The end of the season is a good time for a complete inspection of all of the boat's systems. It is easy to take shortcuts when decommissioning your boat but proper lay-up procedures will ensure trouble free recommissioning in the spring.

The following sections are oriented towards hauling your boat for winter storage in a cold climate, but they are also a good guideline as a lay-up procedure for your Beneteau in any climate.

An improperly winterized boat will lead to costly repairs and extensive delays, we recommend winterization by a competent yard or your Beneteau Dealer. The owner must ensure that the boat is correctly winterized.

### **HAULING**

Your Beneteau should be hauled for inspection and maintenance at least once a year; the frequency of haul-outs may vary due to your local conditions and marine growth. A good boatyard is seasoned in hauling and maneuvering boats on land, you may verify this by checking to see that the weight of the hull is resting firmly on the bottom of the keel and that even contact exists along the bottom of keel. Jack stands, or cradle uprights, are meant to balance the boat and not to support its weight.

### **BOTTOM**

Clean the yacht's bottom of any growth as soon as the boat is hauled. It is generally preferred to wait until spring to paint the bottom. Use the following guidelines when using a pressure washer:

**MAXIMUM WATER TEMPERATURE TO BE 95° F. (35° C.)**

**MAXIMUM PRESSURE TO BE 2175 PSI (150 BARS) AT NO CLOSER THAN 4"**

### **CUTLASS BEARING**

The shaft strut contains a rubber type cutlass bearing. At haul out, be sure the bearing slots are clear and apply silicone lubricant or castor oil to the bearing to preserve its suppleness. Replace the cutlass bearing if excessive wear is evident. Be sure to realign the engine if the bearing is replaced. Bleed the prop shaft seal after re-launching

### **ZINC**

Replace the sacrificial zinc before re-launching the boat.



## FRESHWATER SYSTEM

This system is best winterized with one of the non-toxic antifreezes available for use in boat and recreational freshwater systems. It is an easy method, which replaces fresh water with a non-toxic antifreeze mixture.

**Caution! Be sure to use non-toxic antifreeze in the fresh water system.**

1. Allow the water in the water heater to cool, and open the pressure release valve on top. Disconnect the hot and cold water hoses and allow the tank to drain either in a bucket or into the bilge. Connect and clamp the hot and cold water hoses together using a short length of 1/2" pipe in order to bypass the heater.
2. Mix the appropriate amounts of antifreeze and water, as directed on the label, to deliver the degree of protection desired. Put 1-1/2 to 2 gallons of the solution into each water tank.
3. Open both tank selector valves on the manifold.
4. Turn on the pump and open all fixtures until antifreeze runs through. Be sure to open the hot water selector valve in order to supply antifreeze to the hot water hoses and through the bypass loop.
5. At this point, the freshwater system should be completely protected by antifreeze against freezing to a degree indicated by the strength of the solution placed into the supply tanks.
6. New boats delivered have their freshwater systems filled with antifreeze as described above, and are protected to -30 degrees F.

## HEAD

Several days before completing haul-out procedures, fresh water should be allowed to stand in the head unit to dissolve any salt accumulation in the hoses and pump. Remove all water from the head. Special lubricants for the pump's internal mechanism are available. Check with your marine hardware dealer for a recommended brand. Never put oil, gas, kerosene, or alcohol in the head or they will ruin the internal valve.

Completely pump out all waste from the holding tank and pour in a cleansing, deodorizing solution. If possible, allow this to sit in the tank overnight, then completely pump out and drain the entire system. If antifreeze is used in the system, check in the manufacturer's literature for the recommended type.

## **ENGINE**

Winterization by a marine mechanic is highly recommended to ensure that your engine is properly protected. Consult the Engine Owner's Manual for your specific engine's guidelines for winterizing. Follow the instructions carefully to ensure the engine is adequately protected. The general procedure is to replace raw seawater with an antifreeze solution mixed to protect the engine in your local area and to check the heat exchanger side to ensure that it contains an adequate antifreeze solution as well.

1. Prior to hauling the boat, run the engine to achieve normal operating temperatures in order to open the thermostat.
2. Close the raw water intake thru hull and remove the hose from the valve hose barb.
3. Insert the intake hose in a bucket of antifreeze solution and run the engine briefly until all raw water is flushed thru the exhaust system and only the antifreeze solution is expelled from the exhaust.
4. Be sure the thru hull valve is opened after the boat is hauled.

## **FUEL SYSTEM**

Consult your engine manual to clean any engine mounted fuel filters.

Drain any water from the bottom of the fuel/water separator.

The fuel tank should be kept full for winter storage with about 5% expansion room left at the top. Empty fuel tanks encourage the formation of condensation.

## **BATTERIES**

Clean battery terminals and cable ends thoroughly of any corrosion with a baking soda and water solution, and apply a light protective layer of petroleum jelly.

Batteries should be fully charged before storage, and the fluid level maintained. Store batteries in a warm, dry place. Do not store batteries directly on a stone or cement floor.

## **SEACOCKS**

Open and drain all seacocks after boat is hauled. Open all seacocks for winter storage.

## **BILGE**

Completely pump out bilge of any water and clean out any debris present. Bilge pumps should be pumped dry and hoses disconnected, to ensure that no water is left in the system.

## ICEBOX

Remove any remaining food from the icebox and wash down thoroughly with warm water and detergent solution.

Odors can be removed with a baking soda and water solution, and an open box of baking soda left in the icebox will continue to remove odors throughout storage.

Completely pump out any water from the bottom of the icebox and make sure pump is completely dry of any water.

Leave icebox lid open during storage to allow ventilation.

## STOVE

Depressurize the gas system and close all valves. Clean stove thoroughly. Remove fuel tanks and clean to remove any salt accumulation from their surface. Wipe down stove and tanks with a rag while applying a light layer of WD-40 or other lightweight, protective oil.

## INTERIOR

Remove as much loose gear from the boat as possible and store in a clean dry place. If cushions are left on board be sure they are dry and propped on edge to encourage ventilation.

Rinse and dry all floorboards and store them on their edge to encourage ventilation. Leave all lockers clean and open for ventilation.

## COVERING THE BOAT

Cover the boat adequately during storage to prevent excessive weathering.

### **BE SURE THE COVER DOES NOT CHAFE BOAT.**

Ventilation between the winter cover and the boat is required to avoid build up of humidity.

**CAUTION! DO NOT USE BLACK POLYETHYLENE AND DO NOT SHRINK-WRAP THE BOAT BY TAPING TO THE HULL. ALWAYS ASSURE GOOD VENTILATION.**

## SAILS

Remove the sails, clean following the sail makers recommendations and store in a clean dry space.

## MAST

The aluminum mast requires a minimum of care and maintenance. At the end of each season it should be washed with a mild detergent and water solution, followed by a complete rinsing with fresh water. Tie off all halyards and lifts, and inspect the mast completely for scratches, cracks or stress marks. Apply paint or a clear lacquer to any scratches found to prevent corrosion. Consult your dealer or a marine rigger if any cracking or stressing of the aluminum tube is found.

Check all hardware on mast carefully for signs of corrosion, and check the tightness of the fastenings. Masthead sheaves should show no signs of wear and should move freely. Lubricate if necessary.

## **XXVI) ENVIRONMENT**

Do not pour oil overboard; use appropriate waste containers.

When you fill up the engine fuel tank, take all the precautions in order to avoid overflowing.

In the harbor, do not use the heads if they are not equipped with holding tanks.

The use of detergent contributes to the deterioration of the sea fauna and flora; choose entirely biodegradable products for your cleaning operations.

Do not throw plastic bags overboard.

You love the sea, just as we do; therefore, help us to protect it and do not pollute it.