

QUICKSILVER®

605 Pilothouse Owner's Manual



Welcome

Congratulations on becoming a new owner of a Quicksilver® boat. This Owner's Packet will provide important information about the features of your boat and should be, at all times, kept aboard your boat. Take time to carefully review the information in this packet to really get to know your boat.

The Owner's Packet will contain the following:

- **Model Specific Owner's Manual**
The model specific manual contains information vital to understanding the operation of your boat.
- **Original Equipment Manufacturer (OEM) Information**
The OEM information contains manuals provided by the individual system manufacturers of the equipment installed on your boat. These include items such as engine controls, electronics, and stereos, just to name a few. The Owner's Manual will often refer to information provided by the manufacturers of specific systems.

Please keep this manual in a secure place, and transfer to the new owner when you sell the craft.

Information and assistance is also available via our website, www.quicksilver-boats.com.

Information in this publication is based upon the latest production specifications available at printing. Quicksilver® reserves the right to make changes at any time, without notice, in the colors, equipment, specifications, materials and prices of all models, or to discontinue models. Should changes in production models be made, Quicksilver® is not obligated to make similar changes or modifications to models sold prior to the date of such changes.

QUICKSILVER® • A BRUNSWICK COMPANY

INT 2228518

QUICKSILVER 605PH

FEBRUARY 2016

Table of Contents

Introduction

1. Owner's Manual	vi
2. Your Responsibilities.....	vi
3. Explanation of Safety Labels	vi
4. Dealer Responsibilities.....	vii
5. Craft Identification Number (CIN)	vii
6. Warranty Information.....	vii

General Information

1. Basic Boat Dimensions & Specifications	1
2. Vessel Stability	2
3. Load Capacity	2
4. Passenger Locations	3
5. Design Categories	3
6. Safety Label Locations	4
7. Deck Layout (standard equipment).....	6
8. Deck Layout (optional equipment).....	7
9. Cabin/Interior Liner Layout	8
10. Curtains (optional).....	9
11. Hardtop Layout.....	9
12. Cockpit Storage	10
13. Thru Hull Locations	11
14. Dash Layout	12
15. Navigation Lights	13
16. Engine	14
17. Trailering	14
18. Strong Points	14

System & Component Overview and Operation

1. Fuel System	16
2. Bilge Pumps	18
3. Livewell/Raw Water Washdown (optional) .	19
4. Fish Boxes.....	20

5. Fire Prevention	20
6. Carbon Monoxide Monitor	21
7. Bow Anchor Windlass (optional).....	23
8. Steering	24
9. Engine Controls	25
10. Emergency Engine Shutdown Switch	25
11. SmartCraft® System Gauges.....	26
12. Exterior Helm (optional)	26
13. Diesel Heat (optional)	28
14. Stereo (optional).....	29
15. Windshield Wiper	29
16. Starboard Jump Seat.....	29
17. Cockpit Bench Seat	30
18. Port Flip Seat (optional)	31
19. Cockpit Table	31
20. Sun Awning (optional)	31
21. Canvas (optional).....	32

Electrical Systems

1. DC Electrical.....	34
2. Batteries	34
3. Battery Box	34
4. Battery Selector Switch.....	34
5. Fuses and Breakers	35
6. Electrical Schematics	36

Maintenance

1. Maintenance	39
2. Hull & Deck Surfaces.....	39
3. Component Maintenance	40

Introduction

1. Owner's Manual

The material here and the rest of the Owner's manual packet:

- Gives you basic safety information
- Describes the fundamentals of boat use
- Describes the features of your boat
- Describes the equipment on your boat
- Contains service and maintenance information

You must learn to safely operate this boat as well as read, understand and use the information contained in this package.

What this manual does not give you is a course in boating safety, or how to navigate, anchor or dock your boat. Operating a power boat safely requires more skills, knowledge and awareness than is necessary for a car or truck.

2. Your Responsibilities

For your safety, the safety of your passengers, other boaters and people in the water, you must take a boating safety course and get instruction in the safe and proper handling of your boat. Understand and follow the "Rules of the Road" and learn how to navigate.

Do not forget that a boating license is mandatory in many countries for vessels above a certain engine power. These regulations can vary depending on the country or region that you are located in. Finally, your boat must be registered with the proper navigation authorities. A Declaration of Conformity is part of the documents that you receive with the boat and it must be kept aboard with other official documents at all times. The Declaration of Conformity is mandatory when registering the boat.



3. Explanation of Safety Labels

The most important aspect of boating is safety. Although every effort is made to address the numerous issues regarding the safe usage of your boat, it is strongly recommended that you avail yourself of the training and knowledge available through boating safety courses, etc.

Safety Precautions

Mounted at key locations throughout your boat and duplicated in this manual are labels which advise the owner/operator of imperative safety precautions to follow when operating or servicing equipment. Learn to recognize the degree of precaution and understand the explanations of safety prior to reading this manual. These precautions are not all-inclusive. Always use common sense in the operation of your boat.

- Do not remove or obstruct any safety label.
- Replace any label which becomes illegible. Replacement safety labels can be obtained by calling your dealer

 DANGER
DANGER—Immediate hazards which will result in severe personal injury or death if the warning is ignored.
 CAUTION
CAUTION—Hazards or unsafe practices which could result in minor injury, product or property damage if the warning is ignored.

 WARNING
WARNING—Hazards or unsafe practices which MAY result in severe personal injury or death if the warning is ignored.
NOTICE
NOTICE—Information which is important to proper operation or maintenance, but is not hazard related.

Introduction

4. Dealer Responsibilities

In addition to a pre-delivery check and service of the boat, your dealer is to provide:

- A description and demonstration of the safety systems, features, instruments and controls on your boat
- An orientation in the general operation of your boat
- A review of all warranty information and how to obtain warranty service
- The Owner Information Package

If you do not receive all of these materials, or have any questions, contact your dealer.

5. Craft Identification Number (CIN)

The Craft Identification Number is located either on the starboard side of the transom, or on the aft starboard side of the hull under the gunwale if the boat has an optional swim platform, and is your boat's most important identifying factor. The CIN consists of a two digit country code indicating the country of origin of the manufacturer and a unique twelve digit code that provides Quicksilver® vital information about your boat. The CIN must be included in all correspondence related to the vessel. Also of vital importance is the engine serial number(s) and part number(s) when ordering parts for your engine.

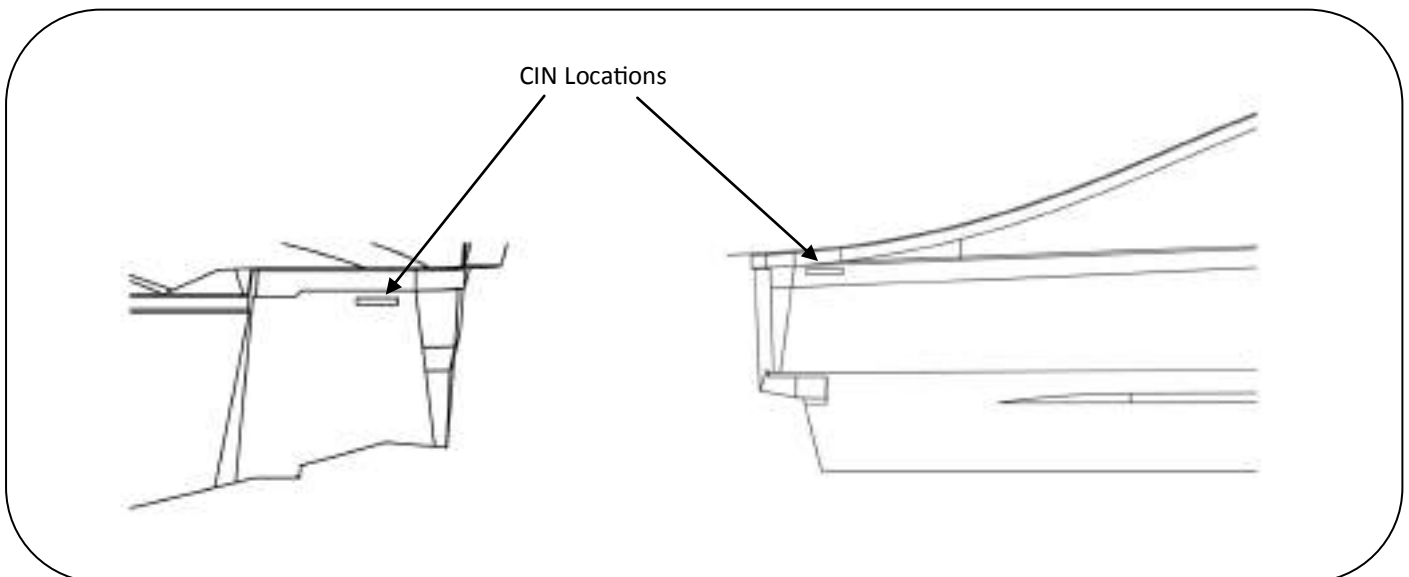

6. Warranty Information

You will find information regarding the Quicksilver® warranty following the introduction. A warranty information card is also included in the owner information packet. If for some reason this information is missing, contact your Quicksilver® dealer.

Registration

Contact your dealer or the distributor in your country, or the Brunswick Marine in EMEA Center closest to you.

Transfer of Warranty

Contact the distributor in your country, or the Brunswick Marine in EMEA Center closest to you.

Introduction



About Your Limited Warranty

The Quicksilver Division of Brunswick Marine in EMEA (Quicksilver®) provides the following Limited Warranty to the original retail owner of its Quicksilver® boat, if purchased from an authorized dealer and operated under normal, subject to remedies, exclusions, and limitations set out in this Limited Warranty.

Europe and Confederation of Independent States

WHAT IS COVERED: Brunswick Marine in EMEA warrants its new products to be free of defects in material and workmanship during the period described below.

DURATION OF COVERAGE: This Limited Warranty provides coverage for two (2) years from the date the product is first sold to a recreational use retail purchaser, or the date on which the product is first put into service, whichever occurs first. Commercial users of these products receive warranty coverage of one (1) year from the date of first retail sale, or one (1) year from the date in which the product was first put into service, whichever occurs first.

Commercial use is defined as any work or employment related use of the product, or any use of the product which generates income, for any part of the warranty period, even if the product is occasionally used for such purposes.

The repair or replacement of parts, or the performance of service under this warranty, does not extend the life of this warranty beyond its original expiration date. Unexpired warranty coverage can be transferred from one recreational use customer to a subsequent recreational use customer upon proper registration of the product. Unexpired warranty coverage may be terminated for use or repossessed product; or product purchased at auction, from a salvage yard, or from an insurance company.

CONDITIONS THAT MUST BE MET IN ORDER TO OBTAIN WARRANTY COVERAGE: Warranty coverage is available only to retail customers that purchase from a Dealer authorized by Brunswick Marine in EMEA to distribute the product in the country in which the sale occurred, and then only after the Brunswick Marine in EMEA specified predelivery inspection process is completed and documented. Warranty coverage becomes available upon proper registration of the product by the authorized dealer. Routine maintenance outlined in the Operation and Maintenance Manual must be timely performed in order to maintain warranty coverage. Brunswick Marine in EMEA reserves the right to make future warranty coverage contingent on proof of proper maintenance.

WHAT BRUNSWICK MARINE IN EMEA WILL DO: Brunswick Marine in EMEA's sole and exclusive obligation under this warranty is limited to, at our option, repairing a defective part, replacing such part or parts with new or Brunswick Marine in EMEA certified remanufactured parts, or refunding the purchase price of the Brunswick Marine in EMEA product. Brunswick Marine in EMEA reserves the right to improve or modify products from time to time without assuming an obligation to modify products previously manufactured.

HOW TO OBTAIN WARRANTY COVERAGE: The customer must provide Brunswick Marine in EMEA with a reasonable opportunity to repair, and reasonable access to the product for warranty service. Warranty claims shall be made by delivering the product for inspection to a Brunswick Marine in EMEA authorized dealer to service the product. If purchaser cannot deliver the product to such a dealer, written notice must be given to Brunswick Marine in EMEA. We will then arrange for the inspection and any covered repair. Purchaser in that case shall pay for all related transportation charges and/or travel time. If the service provided is not covered by this warranty, purchaser shall pay for all related labor and material, and any other expenses associated with that service. Purchaser shall not, unless requested by Brunswick Marine in EMEA, ship the product or parts of the product directly to Brunswick Marine in EMEA. Proof of registered ownership must be presented to the dealer at the time warranty service is requested in order to obtain coverage.

WHAT IS NOT COVERED: As expressly set out herein, all warranties provided by the manufacturers and distributors of components, equipment, and parts ("Component Manufacturer") on the boat are hereby assigned to the owner, to the extent permitted by the Component Manufacturer, as the owner's sole and exclusive remedy with respect to such items. Any assistance by Brunswick Marine in EMEA and/or its authorized dealers with regard to component warranties shall not constitute an adoption of the responsibilities of a component manufacturer with regard to its component warranties. This Limited Warranty does not apply to any Quicksilver® which has been salvaged or declared a total loss or a constructive total loss for any reasons not covered in this Limited Warranty. This Limited Warranty also does not apply to the following items:

1. Engines, drivetrains, controls, propellers, batteries, other equipment or accessories that carry their own individual warranties, or equipment and accessories which are not installed by Quicksilver®
2. Window damage or breakage

Introduction

3. Rainwater leakage, including rainwater leakage through convertible tops
4. Damage or deterioration of cosmetic surface finishes, including cracking, crazing, discoloration, air voids, fading or oxidation of gel coat, wood finishes (varnishes, stains, and paints), fabrics, vinyls, plastics, trim tape, plated or painted metal, stainless steel finishes, anti-fouling bottom paint, or zinc anodes
5. Any Quicksilver® which has been altered or modified from Brunswick Marine in EMEA factory specifications
6. Any Quicksilver® initially sold at retail by a party other than an authorized Brunswick Marine in EMEA dealer
7. Any Quicksilver® which has been used for racing or military purposes, or which has been overpowered according to Brunswick Marine in EMEA factory specifications for such Quicksilver®
8. Any Quicksilver® used for Commercial Purposes. Commercial Purposes, as used herein, means a vessel with more than 50% usage for business or revenue-producing purposes.
9. Any failure or defect caused by an accident, product abuse or misuse, failure of the owner to use, maintain, or store the Quicksilver® as specified in Brunswick Marine in EMEA owner's manual(s), and any other failure to provide reasonable care and maintenance.
10. Any transportation, haul out, or other expenses incurred in returning the Quicksilver® to the selling dealer or to the Brunswick Marine in EMEA factory for warranty service.
11. Any representation or implication relating to speed, range, fuel consumption or estimated performance characteristics.
12. Damage, shrinkage, or deterioration of carpet, upholstery, and exterior canvas tops, enclosures, and weather covers (including rainwater leakage)
13. Any failure or defect caused by an act of nature resulting in damage, cost, or expense
14. Any transportation
15. Any failure or defect arising from a previous repair made by a non-authorized service provider
16. Any item exceeding the expressed coverage limits specified in any Brunswick Marine in EMEA Limited Warranty
17. Any defect or repair requiring redesign of the Quicksilver®, except pursuant to the recall provisions of the United States Federal Boat Safety Act of 1971, or the recall laws of any other foreign jurisdiction.

SOLE REMEDY: The remedy of repair or replacement of parts that are found to be defective in factory materials or workmanship covered by the Limited Warranty shall constitute the owner's sole and exclusive remedy against Brunswick Marine in EMEA for any claims whatsoever of economic loss resulting from product failure.

In keeping with environmental policies and practices, Brunswick Marine in EMEA reserves the right to utilize reconditioned, refurbished, repaired or remanufactured products or parts in the warranty repair or replacement process. Such products and parts will be comparable in function and performance to an original product or part and warranted for the remainder of the original warranty period. In no event shall any repair or replacement under this Limited Warranty exceed the fair market value of the product as of the date of the owner's claim. Acceptance of any product returned or any refund provided by Brunswick Marine in EMEA shall not be deemed an admission that the product is defective. Products that are replaced become the property of Brunswick Marine in EMEA.

OTHER LIMITATIONS: Except as set forth herein or on any other written Limited Warranties by Brunswick Marine in EMEA, there are no other warranties, expressed or implied provided by Brunswick Marine in EMEA, on this Quicksilver®. All other warranties, expressed or implied are expressly excluded. Brunswick Marine in EMEA further disclaims any liability for economic loss arising from claims of product failure, negligence, defective design, manufacturing defect, failure to warn and/or instruct, lack of seaworthiness, and any other theory of liability not expressly covered under the terms of this Limited Warranty.

Any implied warranty of merchantability or fitness for a particular purpose is disclaimed. To the extent the implied warranty cannot be disclaimed, it is limited to the shorter of one (1) year from the date of delivery to the first retail owner or the duration of the respective Limited Warranties stated herein. To the extent required by law and implied warranty of merchantability is limited for the duration of the respective Limited Warranties stated. To the extent allowed by law neither Brunswick Marine in EMEA, nor the selling dealer shall have any responsibility of the loss of use of the Quicksilver®, loss of time, inconvenience, commercial loss or consequential damages.

Some countries, states or regions do not allow limitations on how long an implied warranty lasts, so the above limitations may not be applicable. Some countries, states or regions do not allow the exclusion or limitations of incidental or consequential damages, so the above limitations or exclusions may not be applicable. This warranty gives the owner specific legal rights, and the owner may also have other rights, which vary country to country, state to state, or region to region.

Retail customers in the European Economic area (EEA) may have legal rights under the applicable national legislation regarding the sale of consumer goods which are not affected by this Limited Warranty. The retail customer's legal rights under any applicable national legislation regarding the sale of consumer goods shall not be affected. Information on authorized EEA dealers and EEA Privacy be obtained at www.Quicksilver-boats.com.

Introduction

STATUTE OF LIMITATIONS: Any action for rescission or revocations against Brunswick Marine in EMEA shall be barred unless it is commenced within one (1) year from the date of accrual of such cause of action. This provision does not grant any consumer a right of rescission or revocation against Brunswick Marine in EMEA, where such does not otherwise exist under applicable law. Some country, state, or region may not allow the applicable statute of limitations for rescission or revocation to be reduced, so this provision may not apply to each retail owner.

OWNER'S OBLIGATIONS: Contact the selling Brunswick Marine in EMEA dealer to set up an appointment for warranty repairs. All warranty work or repairs must be referred to the selling dealer for authorization as a condition precedent to Limited Warranty coverage. Brunswick Marine in EMEA must receive written notice of any remaining warranty claims from the owner prior to the expiration of the owner's Limited Warranty, and the owner must notify Brunswick Marine in EMEA of any Quicksilver® being repaired by an authorized Brunswick Marine in EMEA dealer which has been at the dealership for fifteen (15) days, or of any claimed defect which was not corrected after one (1) repair attempt.

MODIFICATIONS & SEVERABILITY: The terms and conditions contained herein, as well as those of any documents prepared in conjunction with the sale of this vessel may not be modified, altered, or waived by any action, inaction, or representations, whether oral or in writing, except upon the expressed, written authority of a management level employee of Brunswick Marine in EMEA. The invalidity or unenforceability of any one or more of the provisions herein shall not affect the validity and enforceability of the other provisions.

Africa and Middle East

WHAT IS COVERED: Brunswick Marine in EMEA warrants its new products to be free of defects in material and workmanship during the period described below.

DURATION OF COVERAGE: This Limited Warranty provides coverage for one (1) years from the date the product is first sold to a recreational use retail purchaser, or the date on which the product is first put into service, whichever occurs first. Commercial users of these products receive warranty coverage of one (1) year from the date of first retail sale, or one (1) year from the date in which the product was first put into service, whichever occurs first.

Commercial use is defined as any work or employment related use of the product, or any use of the product which generates income, for any part of the warranty period, even if the product is occasionally used for such purposes.

The repair or replacement of parts, or the performance of service under this warranty, does not extend the life of this warranty beyond its original expiration date. Unexpired warranty coverage can be transferred from one recreational use customer to a subsequent recreational use customer upon proper registration of the product. Unexpired warranty coverage may be terminated for use or repossessed product; or product purchased at auction, from a salvage yard, or from an insurance company.

CONDITIONS THAT MUST BE MET IN ORDER TO OBTAIN WARRANTY COVERAGE: Warranty coverage is available only to retail customers that purchase from a Dealer authorized by Brunswick Marine in EMEA to distribute the product in the country in which the sale occurred, and then only after the Brunswick Marine in EMEA specified predelivery inspection process is completed and documented. Warranty coverage becomes available upon proper registration of the product by the authorized dealer. Routine maintenance outlined in the Operation and Maintenance Manual must be timely performed in order to maintain warranty coverage. Brunswick Marine in EMEA reserves the right to make future warranty coverage contingent on proof of proper maintenance.

WHAT BRUNSWICK MARINE IN EMEA WILL DO: Brunswick Marine in EMEA's sole and exclusive obligation under this warranty is limited to, at our option, repairing a defective part, replacing such part or parts with new or Brunswick Marine in EMEA certified remanufactured parts, or refunding the purchase price of the Brunswick Marine in EMEA product. Brunswick Marine in EMEA reserves the right to improve or modify products from time to time without assuming an obligation to modify products previously manufactured.

HOW TO OBTAIN WARRANTY COVERAGE: The customer must provide Brunswick Marine in EMEA with a reasonable opportunity to repair, and reasonable access to the product for warranty service. Warranty claims shall be made by delivering the product for inspection to a Brunswick Marine in EMEA authorized dealer to service the product. If purchaser cannot deliver the product to such a dealer, written notice must be given to Brunswick Marine in EMEA. We will then arrange for the inspection and any covered repair. Purchaser in that case shall pay for all related transportation charges and/or travel time. If the service provided is not covered by this warranty, purchaser shall pay for all related labor and material, and any other expenses associated with that service. Purchaser shall not, unless requested by Brunswick Marine in EMEA, ship the product or parts of the product directly to Brunswick Marine in EMEA. Proof of registered ownership must be presented to the dealer at the time warranty service is requested in order to obtain coverage.

Introduction

WHAT IS NOT COVERED: As expressly set out herein, all warranties provided by the manufacturers and distributors of components, equipment, and parts (“Component Manufacturer”) on the boat are hereby assigned to the owner, to the extent permitted by the Component Manufacturer, as the owner’s sole and exclusive remedy with respect to such items. Any assistance by Brunswick Marine in EMEA and/or its authorized dealers with regard to component warranties shall not constitute an adoption of the responsibilities of a component manufacturer with regard to its component warranties. This Limited Warranty does not apply to any Quicksilver® which has been salvaged or declared a total loss or a constructive total loss for any reasons not covered in this Limited Warranty. This Limited Warranty also does not apply to the following items:

1. Engines, drivetrains, controls, propellers, batteries, other equipment or accessories that carry their own individual warranties, or equipment and accessories which are not installed by Quicksilver®
2. Window damage or breakage
3. Rainwater leakage, including rainwater leakage through convertible tops
4. Damage or deterioration of cosmetic surface finishes, including cracking, crazing, discoloration, air voids, fading or oxidation of gel coat, wood finishes (varnishes, stains, and paints), fabrics, vinyls, plastics, trim tape, plated or painted metal, stainless steel finishes, anti-fouling bottom paint, or zinc anodes
5. Any Quicksilver® which has been altered or modified from Brunswick Marine in EMEA factory specifications
6. Any Quicksilver® initially sold at retail by a party other than an authorized Brunswick Marine in EMEA dealer
7. Any Quicksilver® which has been used for racing or military purposes, or which has been overpowered according to Brunswick Marine in EMEA factory specifications for such Quicksilver®
8. Any Quicksilver® used for Commercial Purposes. Commercial Purposes, as used herein, means a vessel with more than 50% usage for business or revenue-producing purposes.
9. Any failure or defect caused by an accident, product abuse or misuse, failure of the owner to use, maintain, or store the Quicksilver® as specified in Brunswick Marine in EMEA owner’s manual(s), and any other failure to provide reasonable care and maintenance.
10. Any transportation, haul out, or other expenses incurred in returning the Quicksilver® to the selling dealer or to the Brunswick Marine in EMEA factory for warranty service.
11. Any representation or implication relating to speed, range, fuel consumption or estimated performance characteristics.
12. Damage, shrinkage, or deterioration of carpet, upholstery, and exterior canvas tops, enclosures, and weather covers (including rainwater leakage)
13. Any failure or defect caused by an act of nature resulting in damage, cost, or expense
14. Any transportation
15. Any failure or defect arising from a previous repair made by a non-authorized service provider
16. Any item exceeding the expressed coverage limits specified in any Brunswick Marine in EMEA Limited Warranty
17. Any defect or repair requiring redesign of the Quicksilver®, except pursuant to the recall provisions of the United States Federal Boat Safety Act of 1971, or the recall laws of any other foreign jurisdiction.

SOLE REMEDY: The remedy of repair or replacement of parts that are found to be defective in factory materials or workmanship covered by the Limited Warranty shall constitute the owner’s sole and exclusive remedy against Brunswick Marine in EMEA for any claims whatsoever of economic loss resulting from product failure.

In keeping with environmental policies and practices, Brunswick Marine in EMEA reserves the right to utilize reconditioned, refurbished, repaired or remanufactured products or parts in the warranty repair or replacement process. Such products and parts will be comparable in function and performance to an original product or part and warranted for the remainder of the original warranty period. In no event shall any repair or replacement under this Limited Warranty exceed the fair market value of the product as of the date of the owner’s claim. Acceptance of any product returned or any refund provided by Brunswick Marine in EMEA shall not be deemed an admission that the product is defective. Products that are replaced become the property of Brunswick Marine in EMEA.

OTHER LIMITATIONS: Except as set forth herein or on any other written Limited Warranties by Brunswick Marine in EMEA, there are no other warranties, expressed or implied provided by Brunswick Marine in EMEA, on this Quicksilver®. All other warranties, expressed or implied are expressly excluded. Brunswick Marine in EMEA further disclaims any liability for economic loss arising from claims of product failure, negligence, defective design, manufacturing defect, failure to warn and/or instruct, lack of seaworthiness, and any other theory of liability not expressly covered under the terms of this Limited Warranty.

Any implied warranty of merchantability or fitness for a particular purpose is disclaimed. To the extent the implied warranty cannot be disclaimed, it is limited to the shorter of one (1) year from the date of delivery to the first retail owner or the duration of the respective Limited Warranties stated herein. To the extent required by law and implied warranty of merchantability is limited for the duration of the respective Limited Warranties stated. To the extent allowed by law neither Brunswick Marine in EMEA, nor the selling dealer shall have any responsibility of the loss of use of the Quicksilver®, loss of time, inconvenience, commercial loss or consequential damages.

Introduction

Some countries, states or regions do not allow limitations on how long an implied warranty lasts, so the above limitations may not be applicable. Some countries, states or regions do not allow the exclusion or limitations of incidental or consequential damages, so the above limitations or exclusions may not be applicable. This warranty gives the owner specific legal rights, and the owner may also have other rights, which vary country to country, state to state, or region to region.

Retail customers in the European Economic area (EEA) may have legal rights under the applicable national legislation regarding the sale of consumer goods which are not affected by this Limited Warranty. The retail customer's legal rights under any applicable national legislation regarding the sale of consumer goods shall not be affected. Information on authorized EEA dealers and EEA Privacy be obtained at www.Quicksilver-boats.com.

STATUTE OF LIMITATIONS: Any action for rescission or revocations against Brunswick Marine in EMEA shall be barred unless it is commenced within one (1) year from the date of accrual of such cause of action. This provision does not grant any consumer a right of rescission or revocation against Brunswick Marine in EMEA, where such does not otherwise exist under applicable law. Some country, state, or region may not allow the applicable statute of limitations for rescission or revocation to be reduced, so this provision may not apply to each retail owner.

OWNER'S OBLIGATIONS: Contact the selling Brunswick Marine in EMEA dealer to set up an appointment for warranty repairs. All warranty work or repairs must be referred to the selling dealer for authorization as a condition precedent to Limited Warranty coverage. Brunswick Marine in EMEA must receive written notice of any remaining warranty claims from the owner prior to the expiration of the owner's Limited Warranty, and the owner must notify Brunswick Marine in EMEA of any Quicksilver® being repaired by an authorized Brunswick Marine in EMEA dealer which has been at the dealership for fifteen (15) days, or of any claimed defect which was not corrected after one (1) repair attempt.

MODIFICATIONS & SEVERABILITY: The terms and conditions contained herein, as well as those of any documents prepared in conjunction with the sale of this vessel may not be modified, altered, or waived by any action, inaction, or representations, whether oral or in writing, except upon the expressed, written authority of a management level employee of Brunswick Marine in EMEA. The invalidity or unenforceability of any one or more of the provisions herein shall not affect the validity and enforceability of the other provisions.

Quicksilver 605PH — General Information

1. Basic Boat Dimensions & Specifications

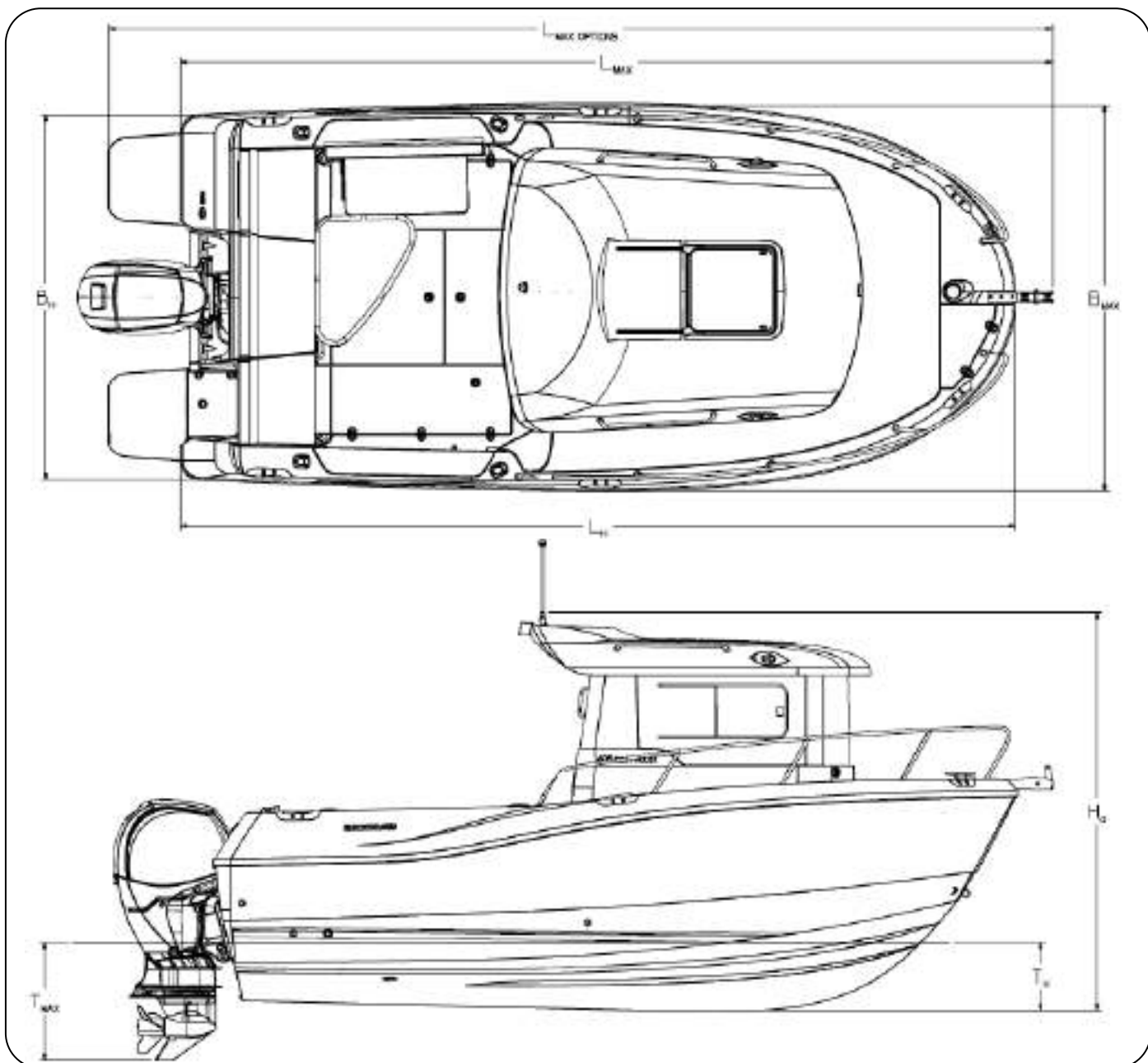

Manufacturer:	Brunswick Marine in EMEA		
Model:	Quicksilver Captur 605PH		
Design Category:	C	Draft Max (T_{MAX}):	0.87m
Length of Hull (L_H):	5.5m	Overall Height (H_a):	2.7m
Length Overall (L_{MAX}):	5.75m	Light Craft Mass (m_{LCC}):	1576 kg
Length Overall ($L_{MAX\ OPTION}$):	6.22m	Maximum Load (m_{MTL}):	630kg
Beam of Hull (B_H):	2.54m	Fully Loaded Mass (m_{LDM}):	2206kg
Beam Max (B_{MAX}):	2.6m	Trailerable Mass (m_T):	1695kg
Draft of Hull (T_H):	0.46m	Fuel Tank Capacity:	160L

Quicksilver 605PH — General Information

2. Vessel Stability

The following maximum load has been used for assessing the stability and buoyancy comprising

- Manufacturer's maximum recommended load per ISO 14946 630kg
- Fuel, fresh water, other fluids to maximum capacity of fixed tanks 119kg

This assessment has been made assuming that

- The boat in the empty craft condition has a mass of 1240kg
- The boat in the light craft condition has a mass of 1576kg
- The maximum recommended engine outboard mass is 239kg
- All standard equipment is aboard.

Your boat was manufactured to specific stability and flotation standards for the capacity shown on the certification plate. Any increase from the recommended load capacities will put your boat in jeopardy of capsizing, swamping and/or sinking. In addition, any changes to the masses aboard may significantly affect the stability, trim, and performance of the craft. Stability can be considerably affected by loose fluids or weight within the vessel. Keep the bilge area as dry as possible, and in rough weather or at planing speeds, keep all openings, hatches, lockers, doorways, and windows closed to minimize flooding. Breaking waves are a serious stability hazard. Finally, stability can be compromised when towing or lifting heavy weights using a davit or boom.

3. Load Capacity

The capacity plate, located near the helm, indicates the maximum weight and number of persons your boat can handle under calm sea conditions. Do not exceed the load capacities stated. A full explanation of this information can be found in the relevant sections of this manual.

The information present on the certification plate does not relieve the operator of responsibility. Use common sense and sound judgment when placing equipment and/or passengers in your boat.

⚠ WARNING

Do not exceed the maximum recommended number of persons. Regardless of the number of persons on board, the total weight of persons and equipment must never exceed the maximum recommended load. Always use the seats/seating spaces provided.

⚠ WARNING

When loading the craft, never exceed the maximum recommended load. Always load the craft carefully and distribute loads appropriately to maintain design trim (approximately level), and secure loose equipment when underway. Avoid placing heavy weights high up.

Quicksilver 605PH Capacity Plate



Quicksilver 605PH — General Information

4. Passenger Locations

⚠ DANGER

Be aware of your footing while the boat is underway. Slipping or falling could result in serious injury or death, especially if the boat is in motion or in rough seas. Keep the accommodation clean, so if movement is necessary, it will be free of obstruction.

⚠ WARNING

Gelcoat surfaces are slippery when wet. Use extreme caution when walking on wet surfaces.
Never occupy the working decks while the boat is underway.

When people are on the working deck area for anchoring, mooring, or in emergencies, they must be holding on and be positioned as to prevent falling overboard.

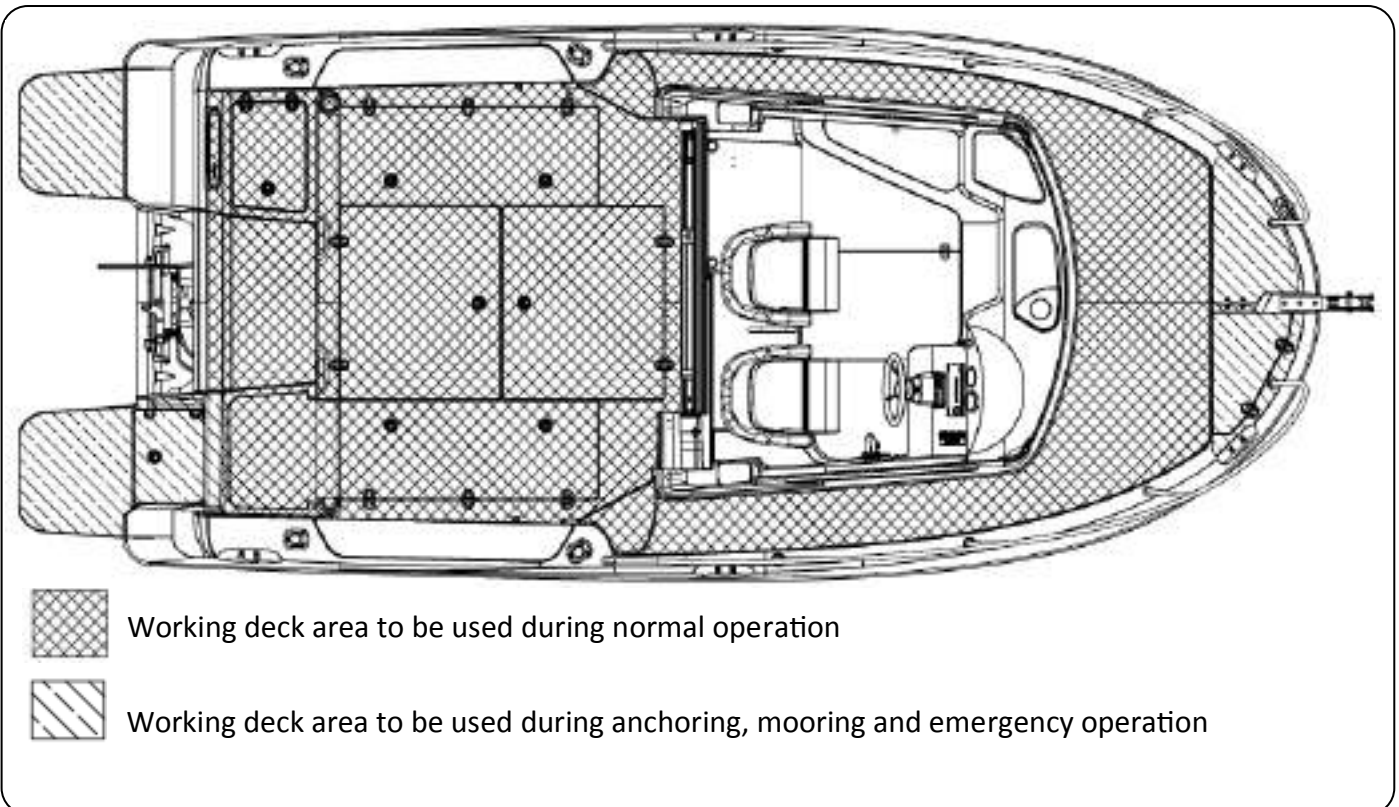

5. Design Categories

There are four design categories of boats based upon their ability to withstand wind and water conditions:

Category A – Designed for winds that may exceed wind force 8 (Beaufort scale – 40 knots) and a significant wave height of 4m and above.

Category B -- Designed for winds that include up to wind force 8 (Beaufort scale – 40 knots) and significant wave height up to and including 4m.

Category C – Designed for winds that include up to a wind force 6 (Beaufort scale – 27 knots) and a significant wave height up to and including 2m.

Category D – Designed for winds that include up to a wind force 4 (Beaufort scale – 16 knots) and a significant wave height up to and including 0.3m, with occasional waves of 0.5m maximum height.

Refer to your product capacity plate for the design category of your boat.

⚠ WARNING

Do not attempt to operate boat in severe weather conditions. Death or serious injury can occur. Get to shore before the weather turns bad.

Quicksilver 605PH — General Information

6. Safety Label Locations—Cockpit

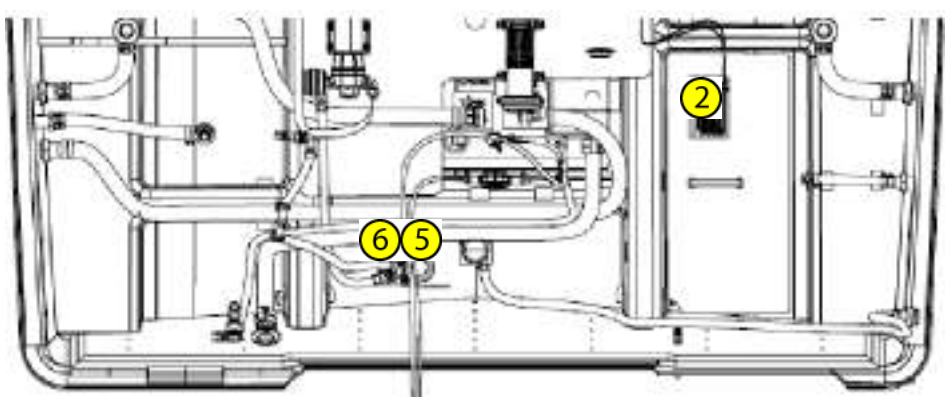
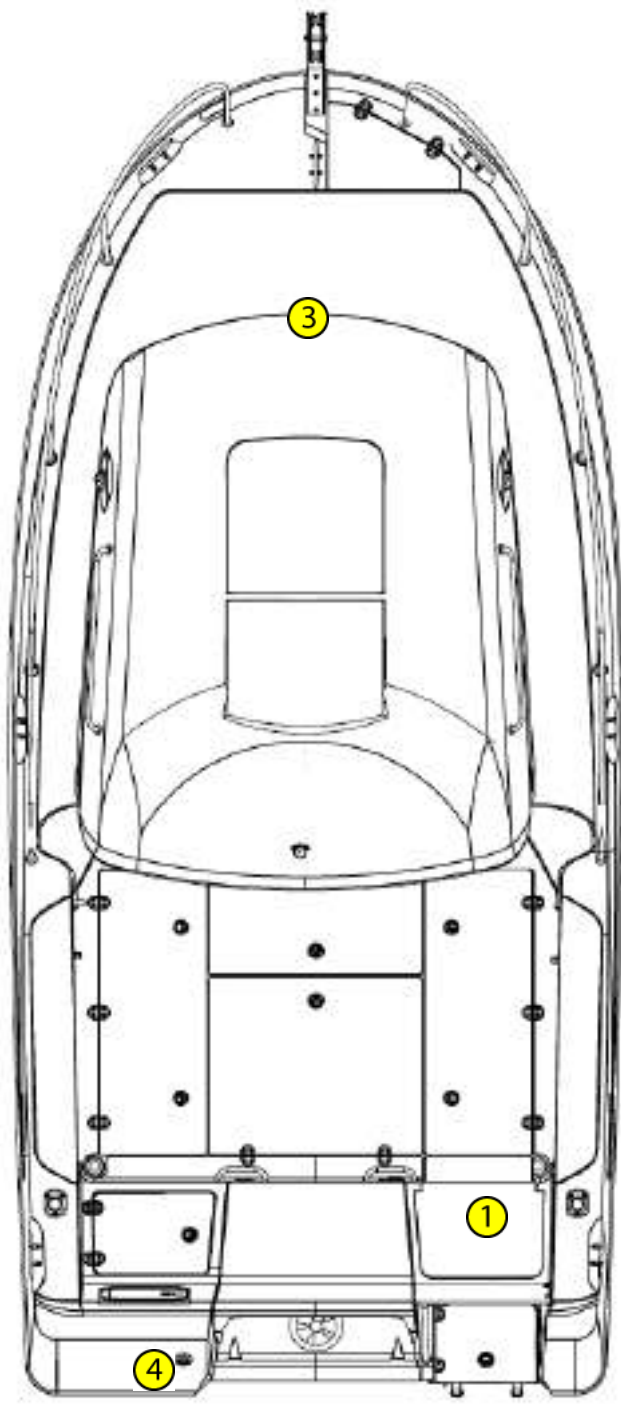
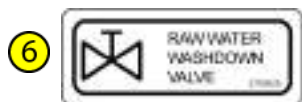
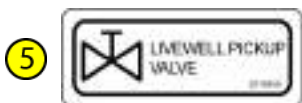
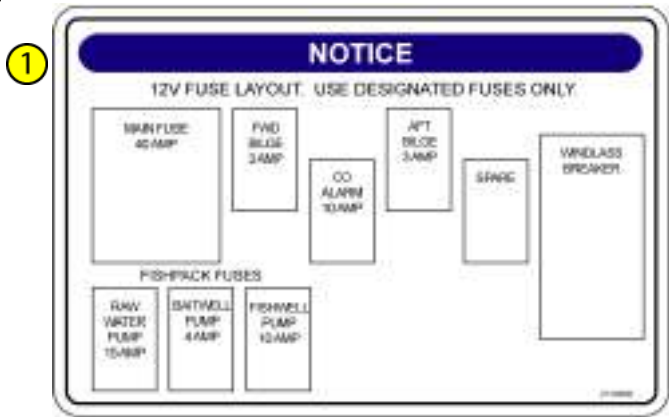

Quicksilver 605PH — General Information

Safety Label Locations—Helm, Transom, & Interior

QUICKSILVER

Brunswick Marine in EMEA
Parc Industriel De Petit Rechain 4800 Verviers - Belgium

605 PH

Category C

Max 6 

Max  +  +  = 720 kg



2118597

110 kW  MAX

2202771

WARNING



Carbon monoxide (CO) can cause brain damage or death. Carbon monoxide can be present in the cabin. Signs of carbon monoxide poisoning include nausea, headache, dizziness, drowsiness, and lack of consciousness. Get fresh air if anyone shows signs of carbon monoxide poisoning. Get fresh air if carbon monoxide detector alarm sounds. Carbon monoxide detector must be functioning at all times.

200771-01

WARNING



Carbon monoxide (CO) can cause brain damage or death. Engine and generator exhaust contains odorless and colorless carbon monoxide gas. Signs of carbon monoxide poisoning include nausea, headache, dizziness, drowsiness, and lack of consciousness. Get fresh air if anyone shows signs of carbon monoxide poisoning. See Owner's Manual for information regarding carbon monoxide poisoning.

200771-01

WARNING



ROTATING PROPELLER MAY CAUSE SERIOUS INJURY OR DEATH. SHUT OFF ENGINE WHEN NEAR SWIMMERS IN THE WATER.

200504

WARNING



ATTACH SHUT DOWN SWITCH LANYARD TO QUALIFIED OPERATOR WHILE ENGINE IS IN OPERATION. UNCONTROLLED BOAT MAY CAUSE INJURY OR DEATH. READ OWNER'S MANUAL BEFORE USE.

200504

WARNING

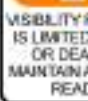

VISIBILITY FROM THIS HELM STATION IS LIMITED. AVOID SERIOUS INJURY OR DEATH FROM COLLISIONS. MAINTAIN A LOCKOUT AS REQUIRED. READ OWNER'S MANUAL.

200504

WARNING



ROTATING PROPELLER MAY CAUSE SERIOUS INJURY OR DEATH. DO NOT BOARD OR USE LADDER IF ENGINE IS RUNNING.

200504

DANGER



Carbon monoxide (CO) can cause brain damage or death. Engine and generator exhaust contains odorless and colorless carbon monoxide gas. Carbon monoxide will be around the back of the boat when engines or generators are running. Move to fresh air, if you feel nausea, headache, dizziness, or drowsiness.

200504

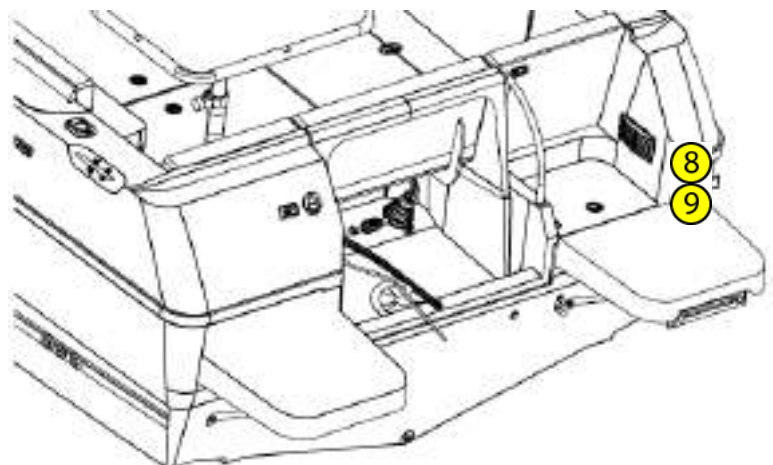
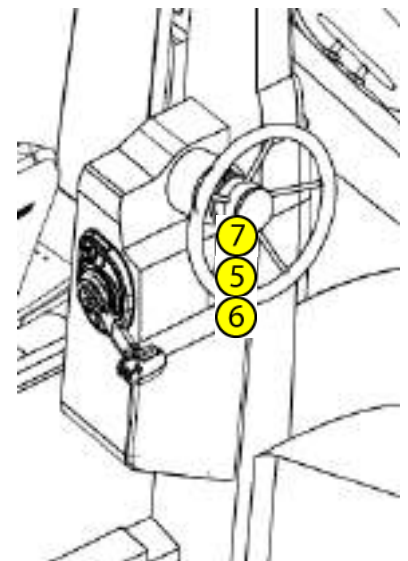
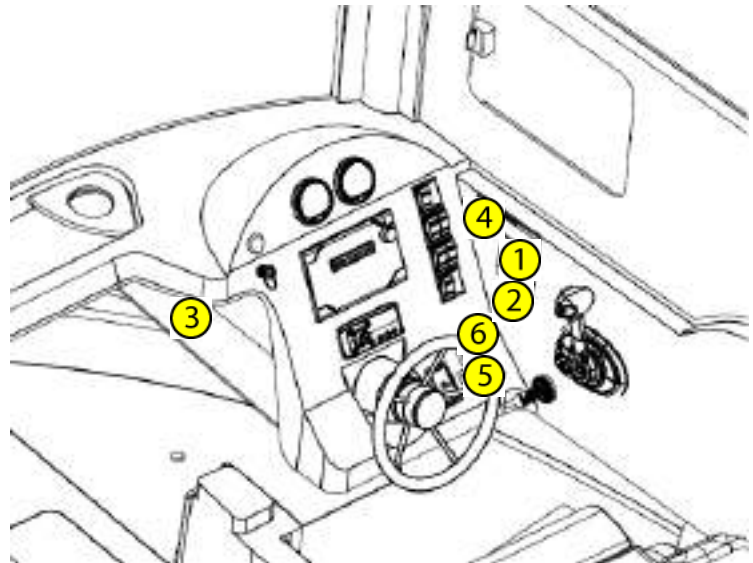

Quicksilver 605PH — General Information

7. Deck Layout (standard equipment)

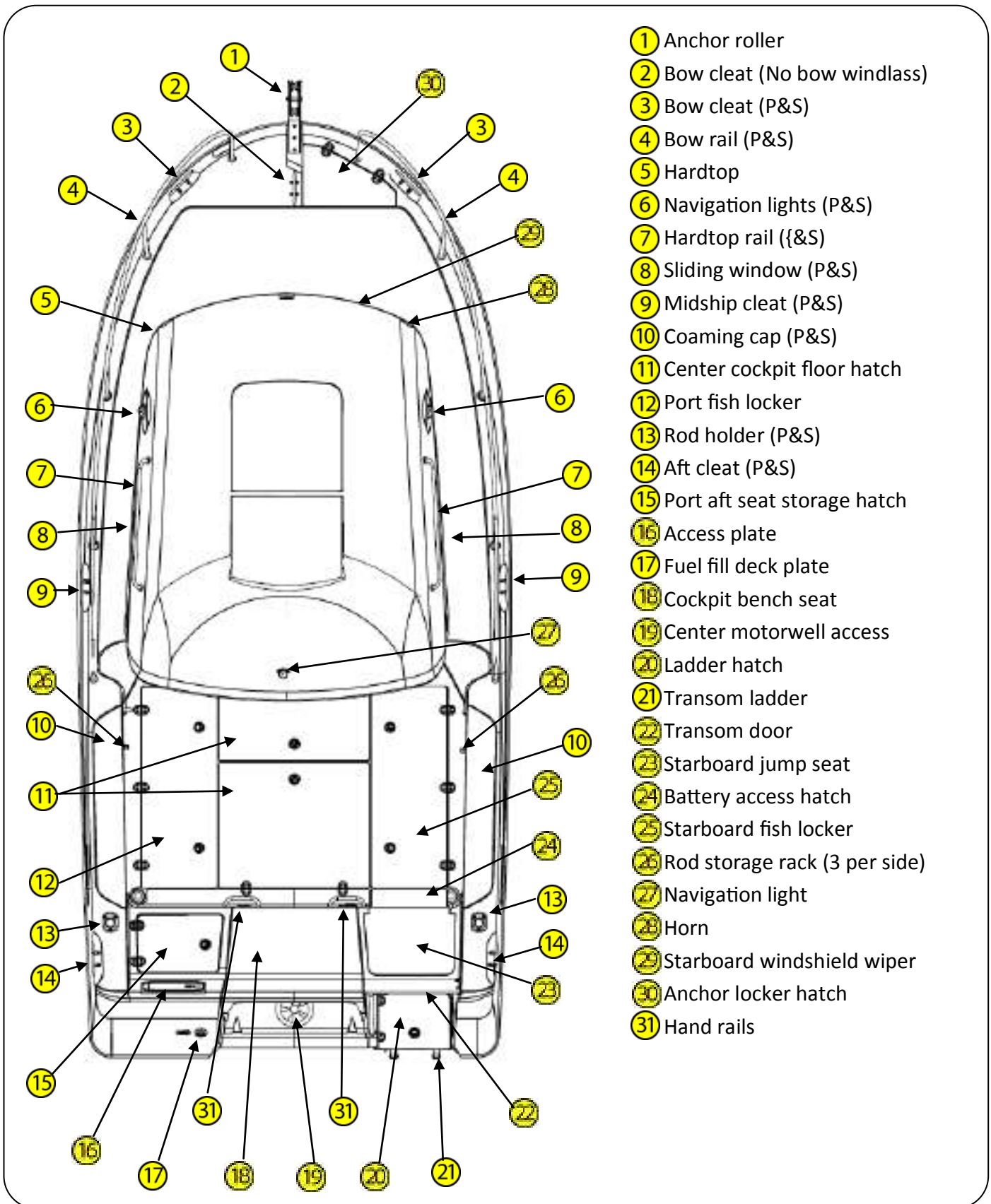

- ① Anchor roller
- ② Bow cleat (No bow windlass)
- ③ Bow cleat (P&S)
- ④ Bow rail (P&S)
- ⑤ Hardtop
- ⑥ Navigation lights (P&S)
- ⑦ Hardtop rail (P&S)
- ⑧ Sliding window (P&S)
- ⑨ Midship cleat (P&S)
- ⑩ Coaming cap (P&S)
- ⑪ Center cockpit floor hatch
- ⑫ Port fish locker
- ⑬ Rod holder (P&S)
- ⑭ Aft cleat (P&S)
- ⑮ Port aft seat storage hatch
- ⑯ Access plate
- ⑰ Fuel fill deck plate
- ⑱ Cockpit bench seat
- ⑲ Center motorwell access
- ⑳ Ladder hatch
- ㉑ Transom ladder
- ㉒ Transom door
- ㉓ Starboard jump seat
- ㉔ Battery access hatch
- ㉕ Starboard fish locker
- ㉖ Rod storage rack (3 per side)
- ㉗ Navigation light
- ㉘ Horn
- ㉙ Starboard windshield wiper
- ㉚ Anchor locker hatch
- ㉛ Hand rails

Quicksilver 605PH — General Information

8. Deck Layout (optional equipment)

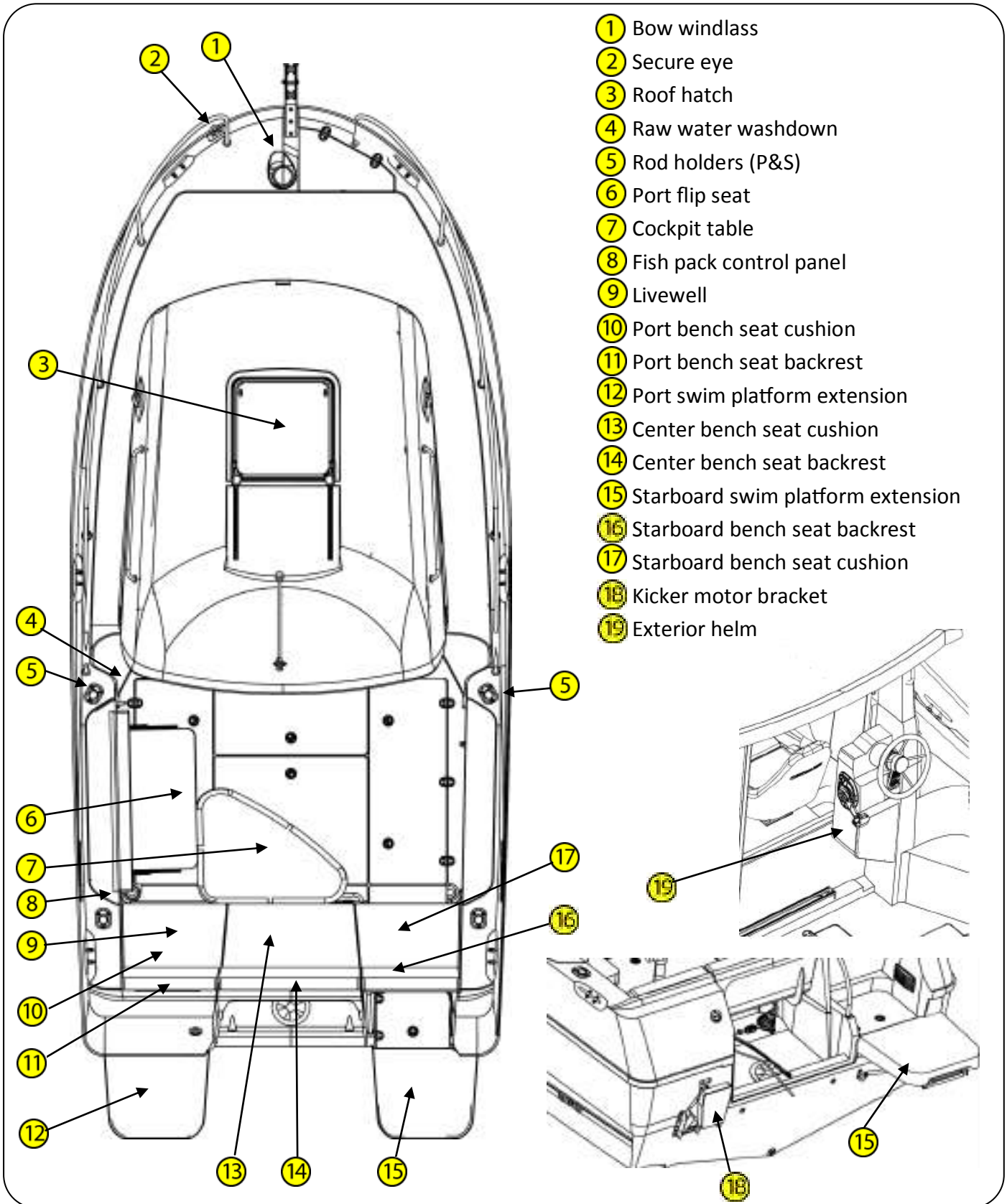

Quicksilver 605PH — General Information

9. Cabin / Interior Liner Layout

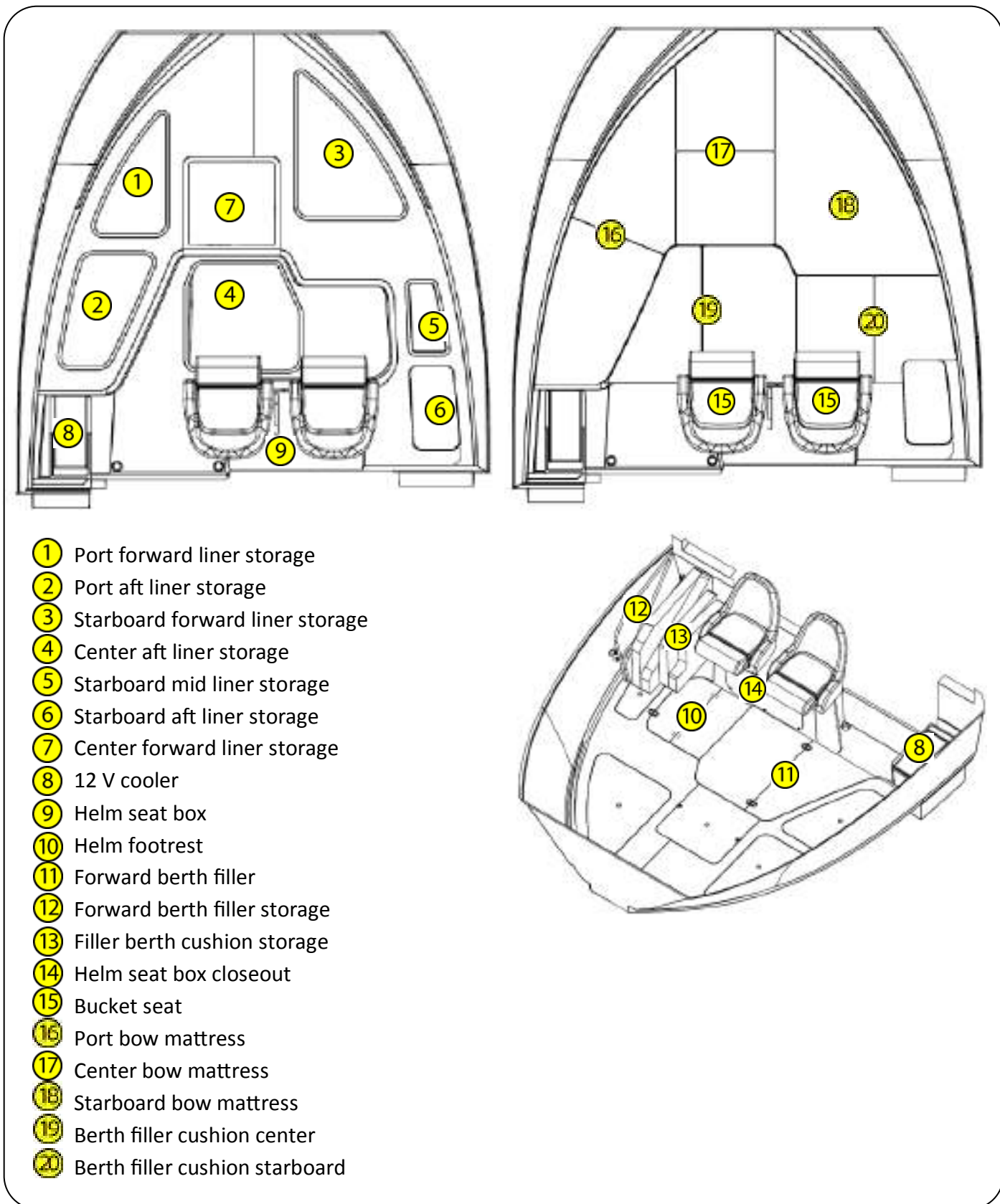

Quicksilver 605PH — General Information

10. Curtains (optional)

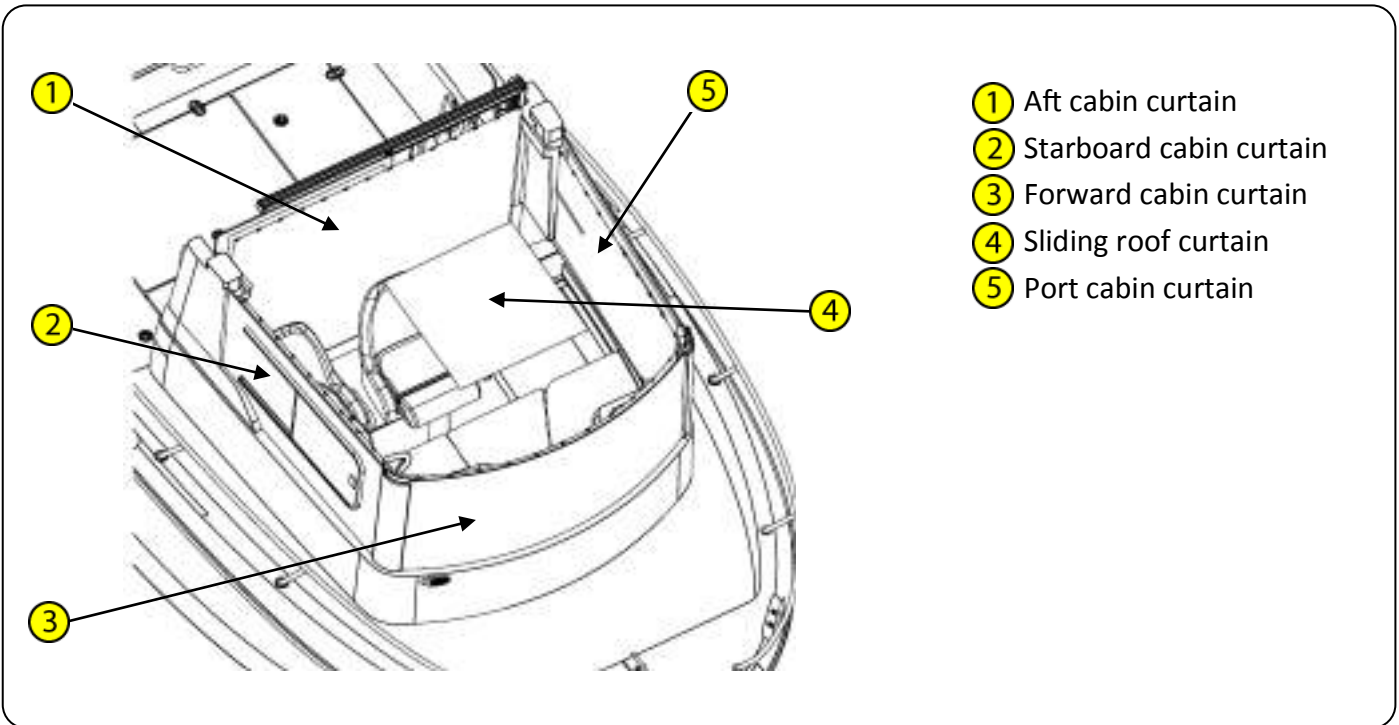

11. Hardtop Layout

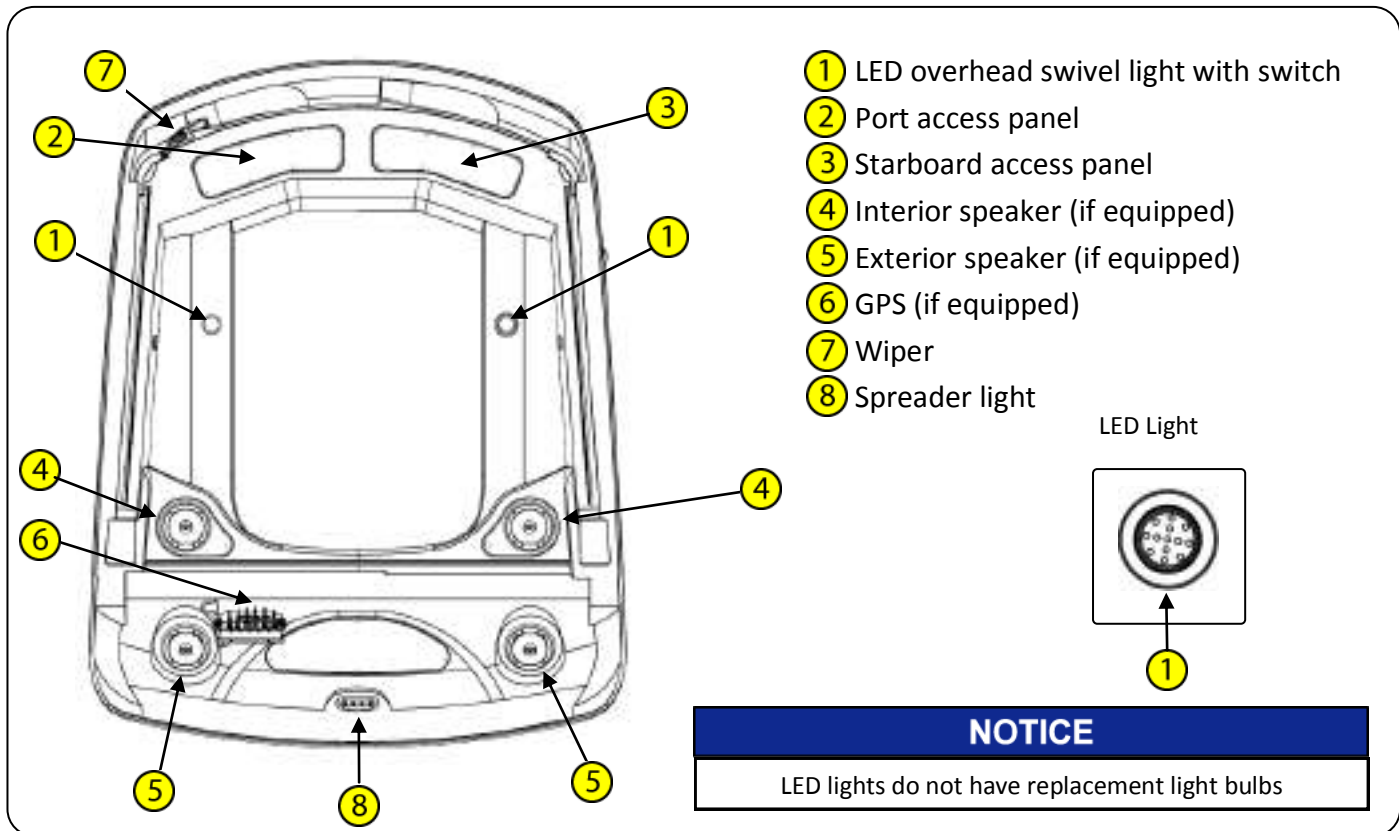

Quicksilver 605PH — General Information

12. Cockpit Storage

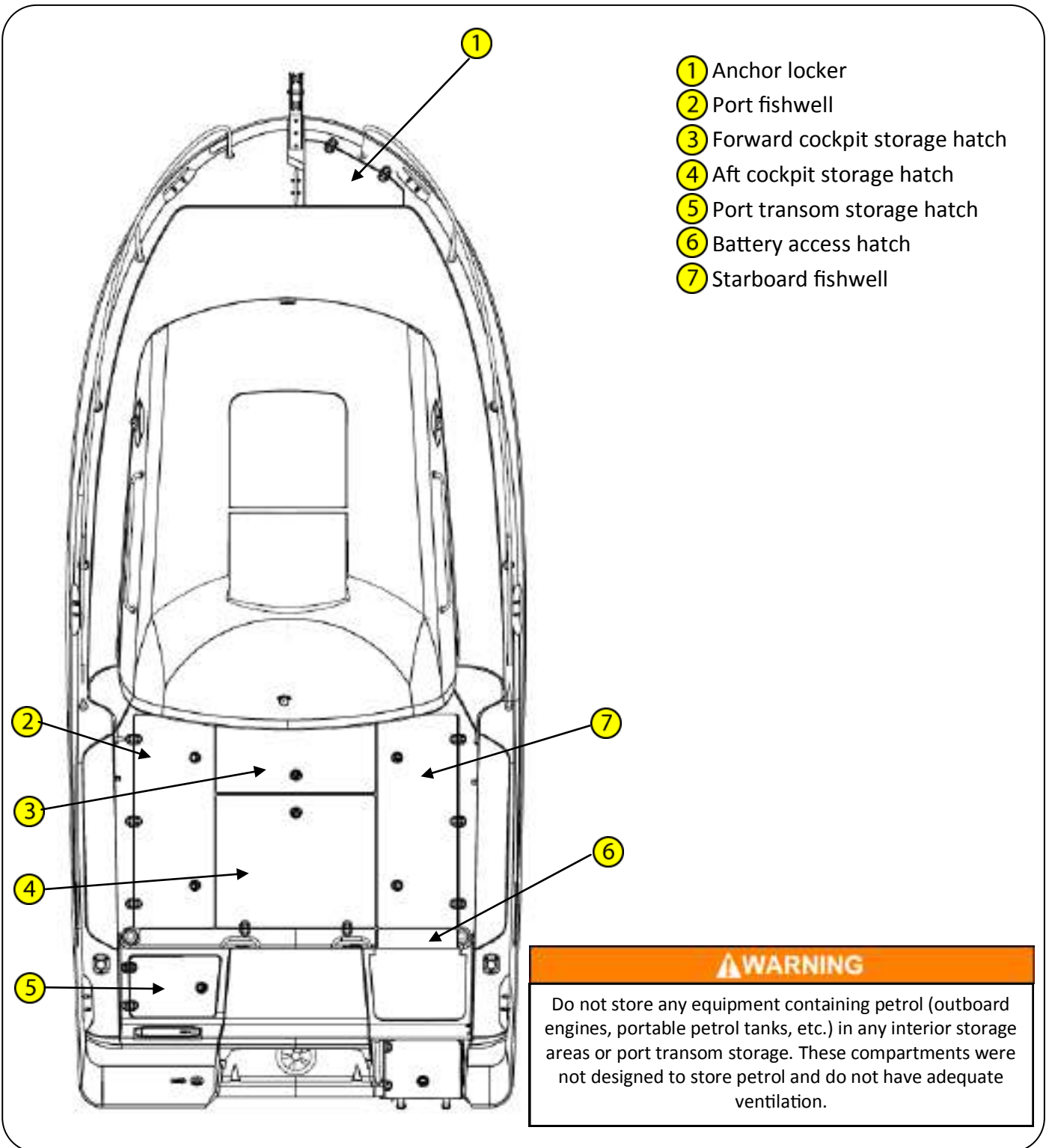

Quicksilver 605PH — General Information

13. Thru Hull Locations

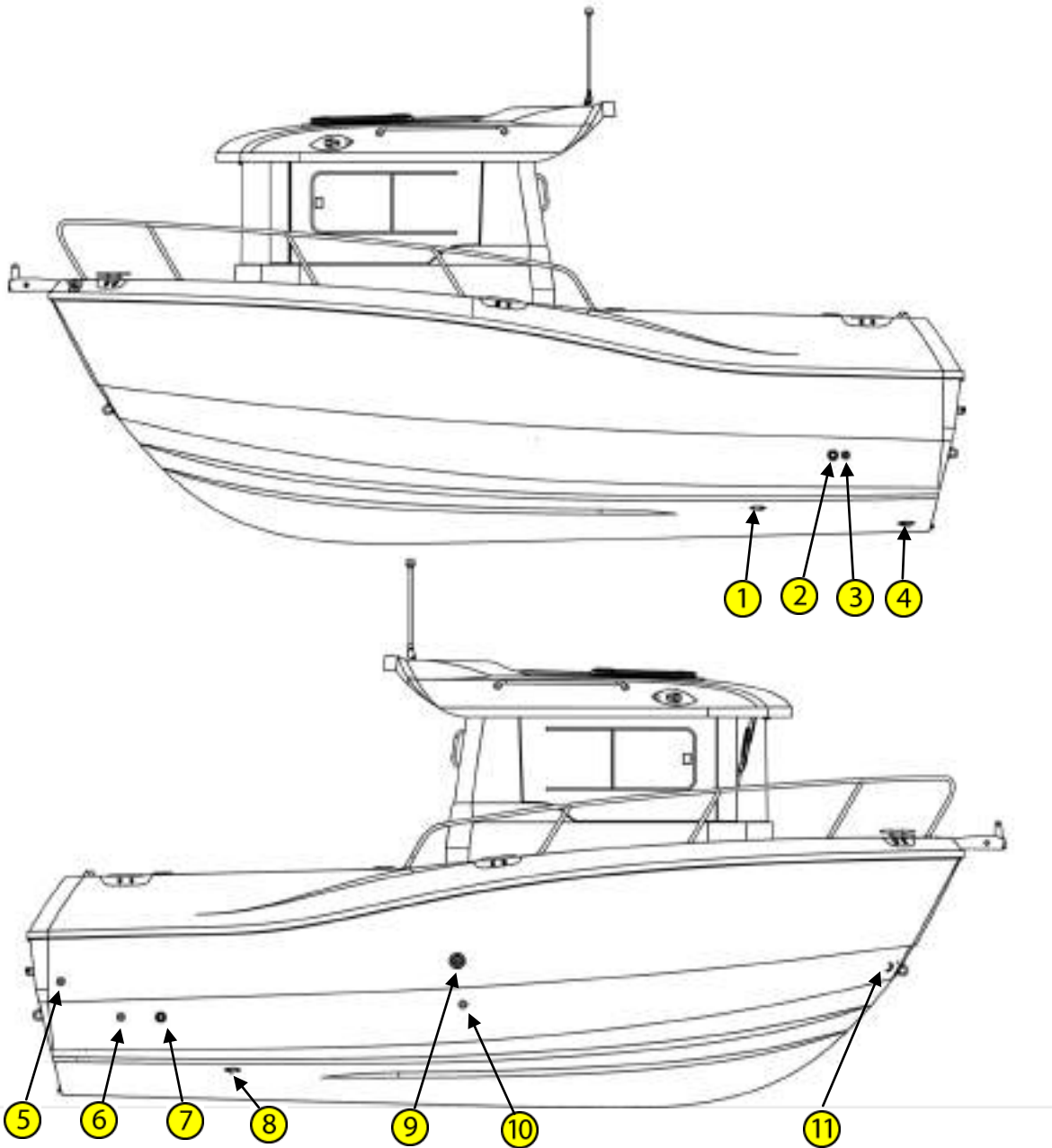

- ① Port fish box drain
- ② Cockpit drain
- ③ Livewell drain (if equipped)
- ④ Livewell pick up (if equipped)
- ⑤ Aft bilge pump drain
- ⑥ Cockpit drain
- ⑦ Cockpit drain
- ⑧ Fish box drain (if equipped)
- ⑨ Heater exhaust (if equipped)
- ⑩ Forward bilge pump drain
- ⑪ Anchor locker drain
- ⑫ Motorwell drain
- ⑬ Garboard drain plug

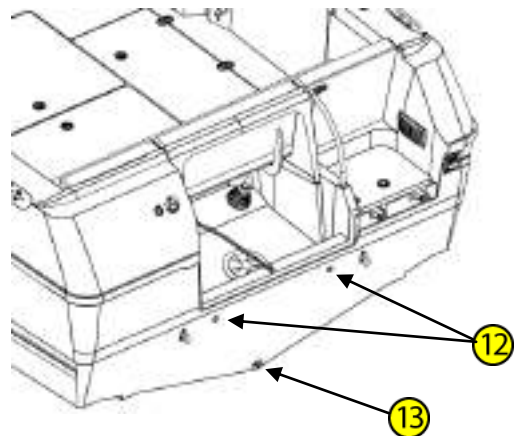

Quicksilver 605PH — General Information

NOTICE

Depending on the type of boat, you may have underwater fittings that need drain plugs. Garboard drain plugs and fishbox drain plugs need to be in place before the boat goes in to the water. Any fitting that will be underwater needs to be plugged or the seacock needs to be closed.

NOTICE

The deck drains provide self-bailing capabilities while the boat is static in the water and no passengers on board. This prevents accumulation of water in the cockpit.

14. Dash Layout (standard equipment)

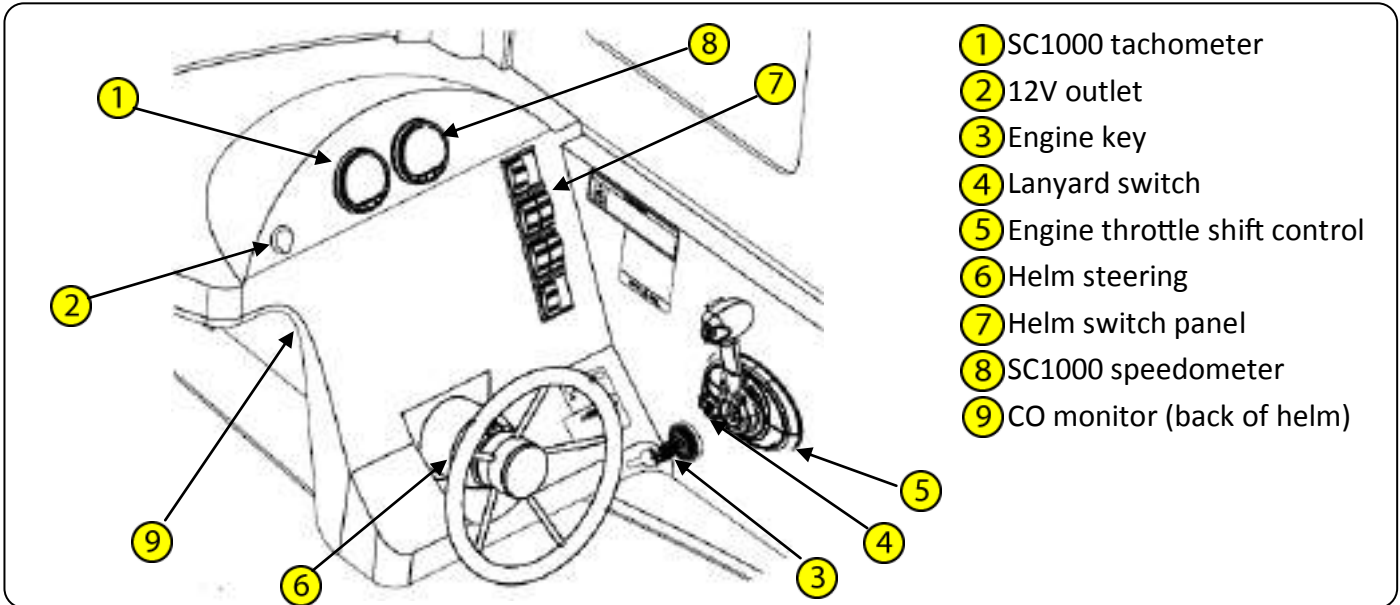

Dash Layout (optional equipment)

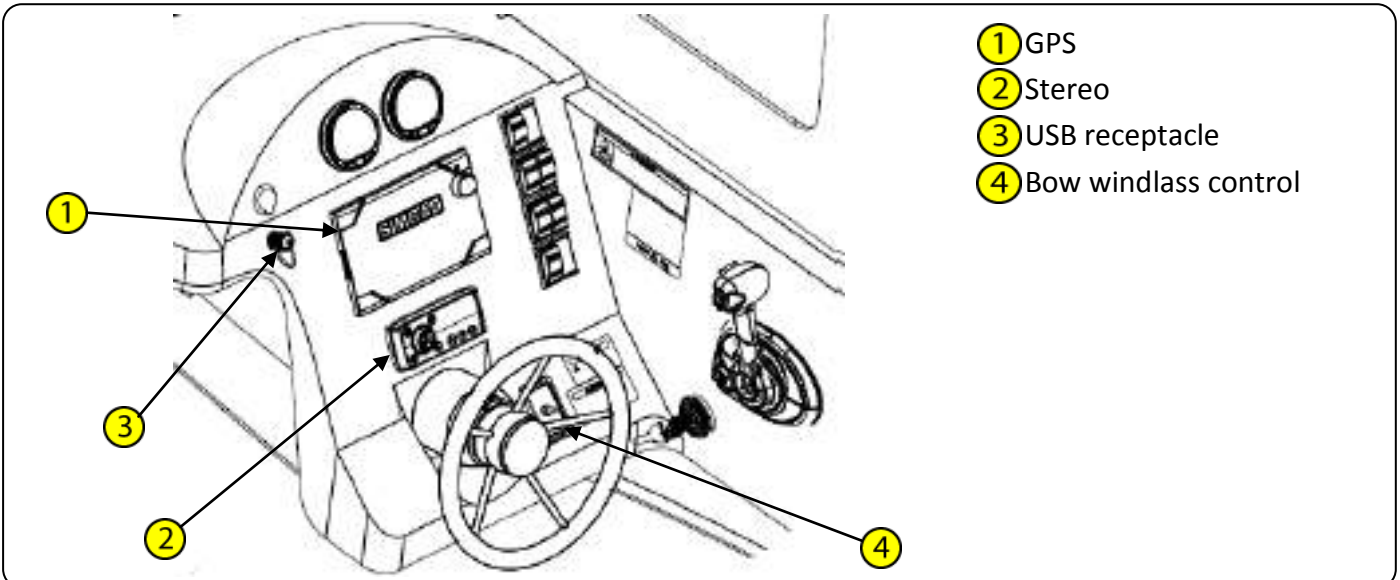

Please note that operator vision from the helm may be obstructed by high trim angles of the craft, along with other factors such as outboard engine trim angles, hull trim plane angles, loading and load distribution, speed & acceleration, transition from displacement to planing mode, sea conditions, rain and spray, darkness and fog, interior lights, position of tops and curtains, and persons or movable gear in the operator's field of vision.

Quicksilver 605PH — General Information

Dash Switch Panel

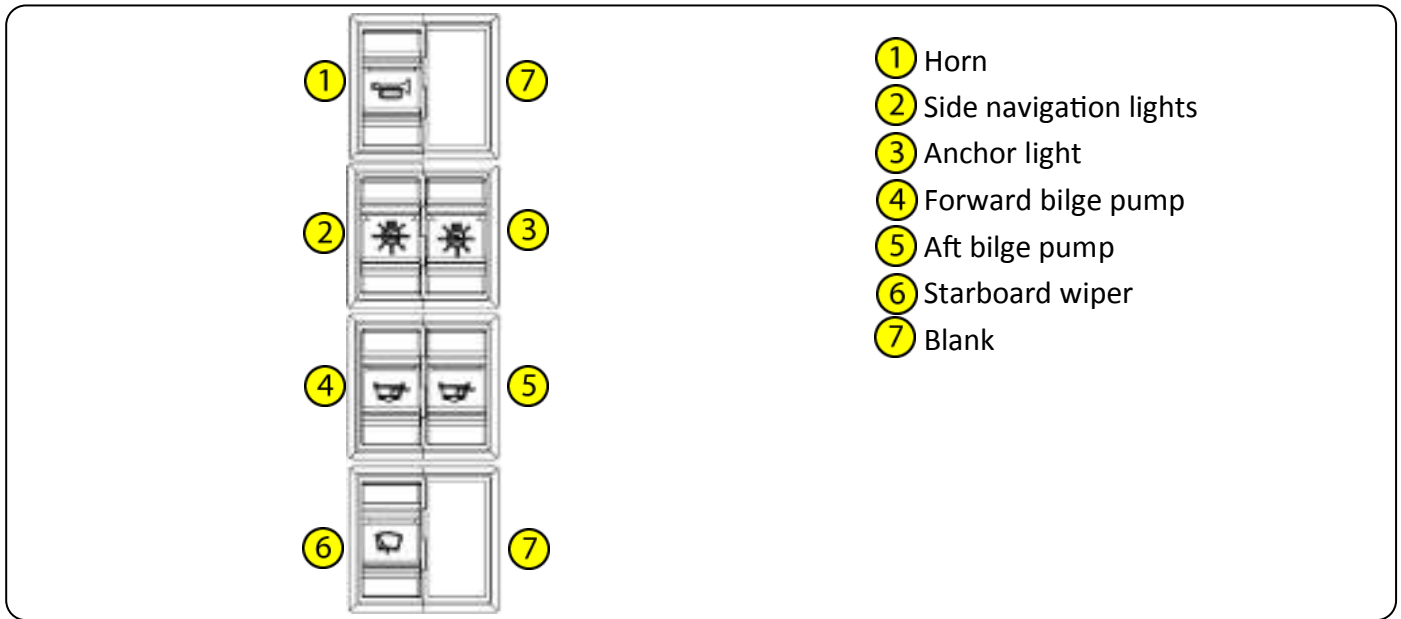

15. Navigation Lights

Your boat comes equipped with navigation lighting for use at night or in low visibility conditions. Prior to running at night, make sure that the all around light located on the hardtop is in the upright position. There are two switches, located on the helm switch panel, that controls these lights. To turn on the Navigation Lights, push the upper part of the left switch forward to illuminate the port (red) and starboard (green) side lights, and push the upper part of the right switch forward to illuminate the all around light (white) showing other vessels that you are underway. To turn on the Anchor Light, only push the upper part of the right switch illuminating the all around light (white), letting other boaters know that you are anchored at a given location.

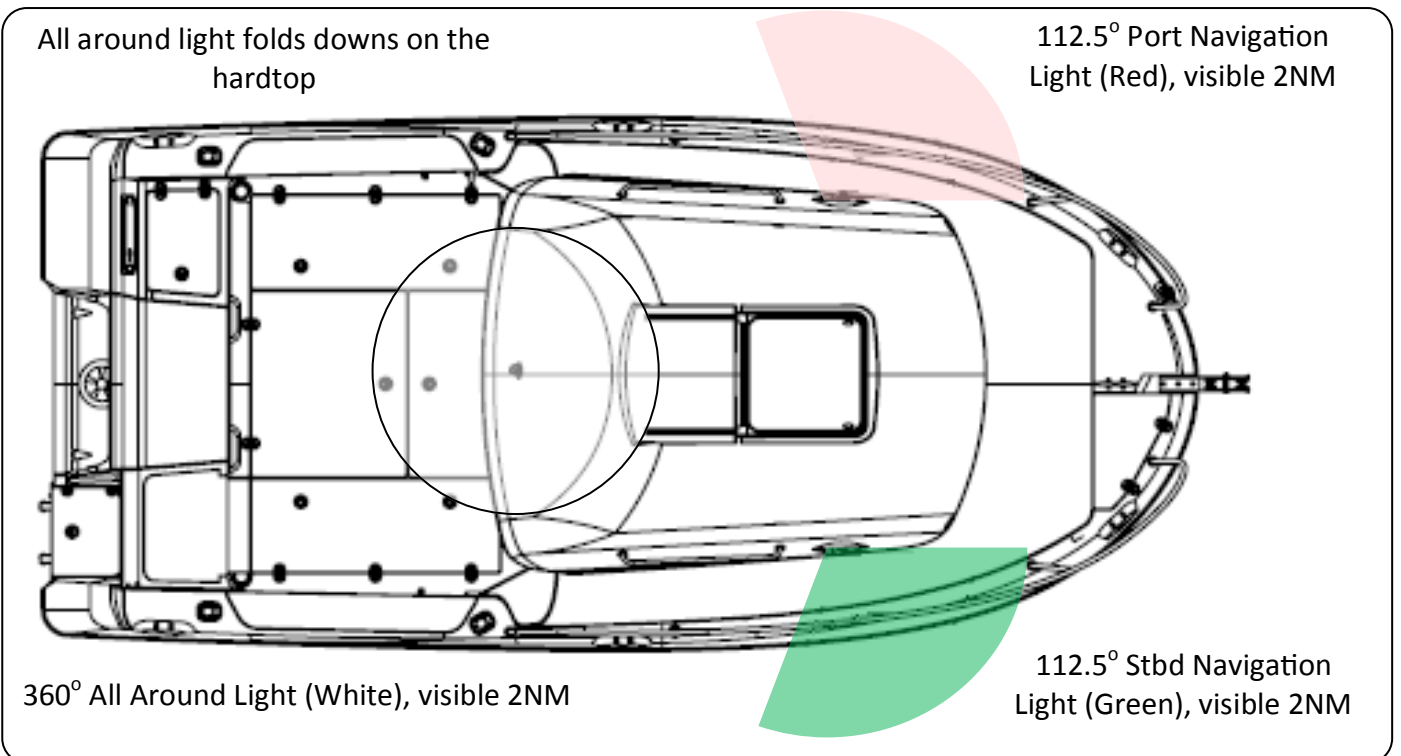

Quicksilver 605PH — General Information

NOTICE

The International Regulations for Preventing Collisions at Sea (COLREG) and the rules of the road require that a proper lookout be maintained at all times and observance of right of way be respected. Always be certain to have sufficient distance to stop or manoeuvre if required to avoid collisions.

16. Engine

Your boat is propelled by a single Mercury outboard engine. The maximum propulsion power rating for the craft is 110 kW. Do not operate this craft with an engine power rating larger than that posted on the power capacity label in the craft. The maximum power rating label is located at the helm, under the capacity plate.

Quicksilver® recommends that you fully comply with the manual provided by the engine manufacturer. Follow the recommended maintenance and warranty schedule in your Engine Operator's Manual. Refer to the Engine Owner's Manual for operating instructions and warranty information. The engines are under warranty from Mercury, not by Quicksilver®.

WARNING

Do not operate this craft with an engine of rated power greater than that posted on the capacity label. Do not operate at maximum speed while in congested waterways, or in weather or sea conditions of reduced visibility, high winds or large waves. Reduce speed and wake as a courtesy to others. Observe & obey speed limits and no wake zones.



110 kW  MAX
2003771

17. Trailering

Quicksilver® does not offer a trailer for this boat, however, if you plan on purchasing one from another vendor, please consider the following:

- The trailer should have a center roller and keel guards which will help provide good support for the keel.
- Trailers with bunks provide a more even weight distribution.
- The mass of your boat in trailering condition is 1695kg. This includes the weight of a fully optioned boat along with full liquid loads. This does not include gear weight usually associated with operating the vessel.

18. Strong Points

Cleats

Your boat comes equipped with six cleats, two located on the bow, two located at midship, and two located at the stern. The cleats are used to secure the boat to the dock while loading, unloading, or mooring. If your boat does not come with a bow windlass, an additional cleat is installed on centerline in the anchor locker for tying off the rode when anchoring.

Bow Eye / Stern Eye

Your boat includes a bow eye, which is used to haul and hold your boat onto a trailer. In addition, there are two stern eyes, located on the transom, which are used as tie down points during trailering the boat. The bow and stern eyes may be used for short term lifting of the boat only.

Quicksilver 605PH — General Information

Towing

Quicksilver® does not recommend towing other boats, or being towed by other boats, unless it is absolutely necessary. In the event that it becomes necessary for you to have your boat towed, a professional company experienced in this type of operation is better equipped to handle this situation.

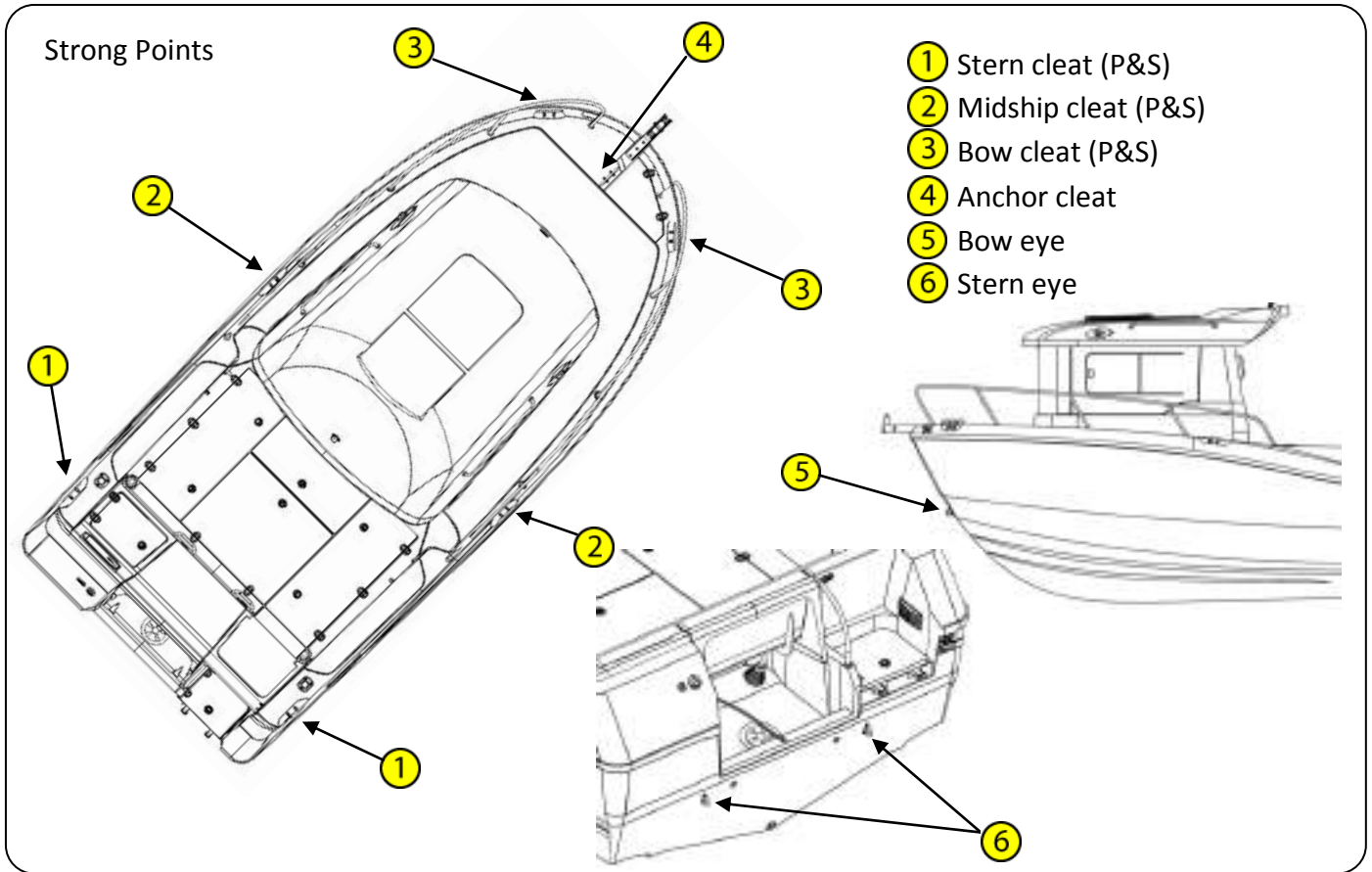

NOTICE

It is the owner's/operators responsibility to ensure that mooring lines, towing lines, anchor chains, anchor lines and anchors are adequate for the vessel's intended use. Owners should also consider what action will be necessary when securing a tow line on board.

⚠ WARNING

Towing or being towed can lead to fatigue of the boat's hardware and lines. Failure of any part can seriously injury people or damage the boat. Do not stand directly in line with the tow line. If the line were to break, it would "snap back" causing injury or damage to everything in its path.

⚠ DANGER

Use only the lifting points specified. Using the cleats for lifting is dangerous and could cause serious injury or death.

⚠ CAUTION

Always tow or be towed at a slow speed. Never exceed the hull speed of a displacement craft when being towed.

Quicksilver 605PH — System & Component Overview and Operation

1. Fuel System

Your boat's petrol fuel system consists of a fuel tank, a fuel tank fill and vent fitting, an anti-siphon valve, a sending unit, and an engine fuel supply line. In addition, there is one extra fuel port for optional pickup, if needed.

NOTICE

GASOLINE RECOMMENDATIONS
Minimum octane rating is 87AKI

CAUTION

The use of improper gasoline or additives can damage your fuel system. Damages caused by improper gasoline or additives will not be covered under warranty.

Fuel System

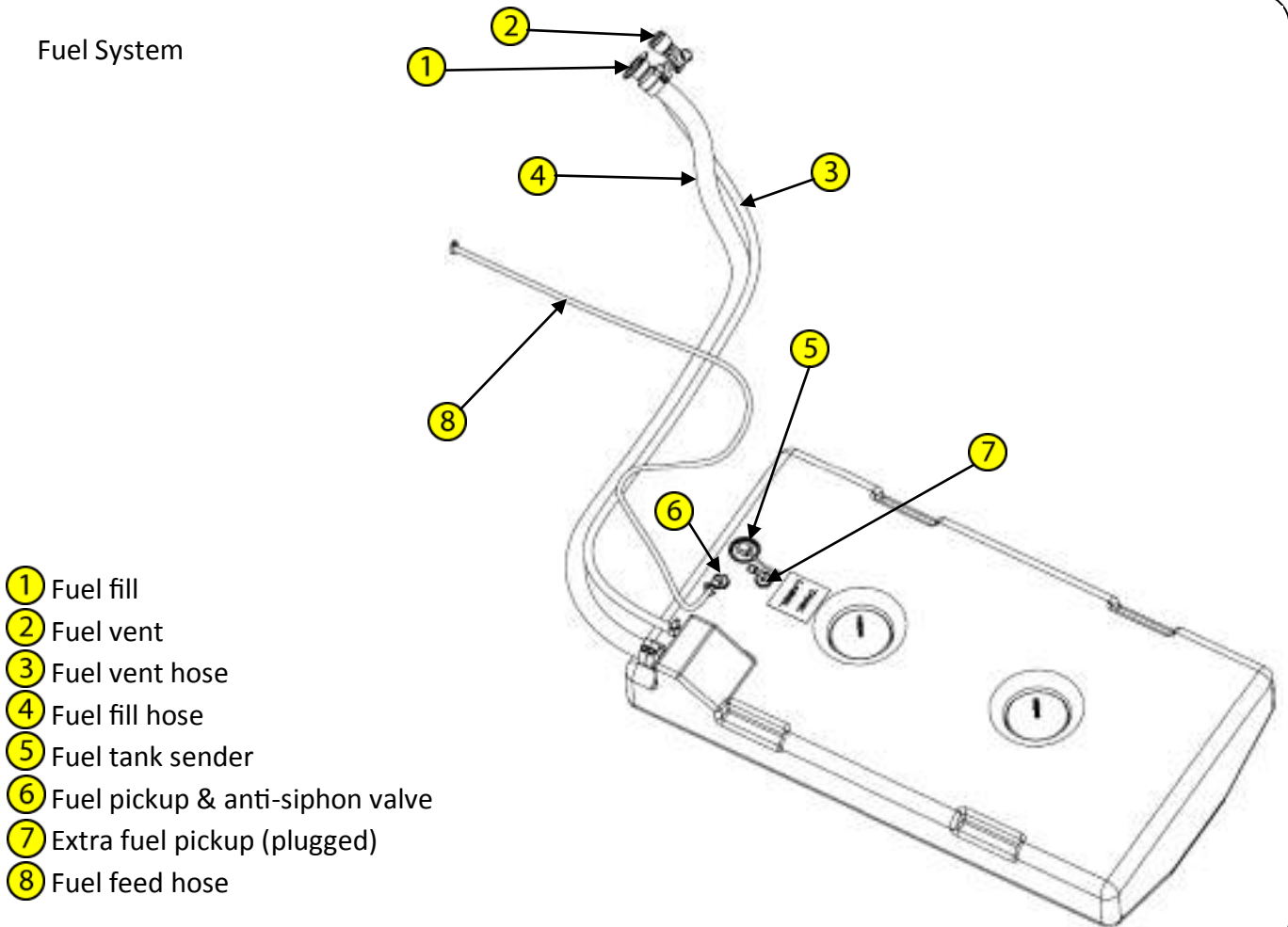

Fuel Tank

Your boat is equipped with a crosslink polyethylene fuel tank with a capacity of 160 liters. As a precaution, all of the capacity may not be useable due to trim and loading conditions, so consider keeping at a minimum 25% reserve fuel in the tank.

Fuel tanks with levels less than 25% capacity can cause engine stalling problems due to fuel starvation or by allowing sediment and dirt to enter the fuel supply lines. Keep the tank full and monitor the fuel level often to prevent this from happening.

Fuel Distribution

Fuel is delivered from the tank to the engine through the anti-siphon valve and the fuel feed line. The anti-siphon valve is a safety feature designed to prevent fuel from siphoning out of the tank if the fuel

Quicksilver 605PH — System & Component Overview and Operation

feed line was ever cut or broken below the level of the fuel in the tank. If the feed line ever broke, some fuel would leak out from the line, however, the anti-siphon valve prevents the entire contents of the tank to siphon into the boat.

NEVER REMOVE OR MODIFY THE ANTI-SIPHON VALVE FROM THE FUEL TANK.

Ethanol—Blended Fuels

Ethanol is an oxygenated hydrocarbon compound that has a high octane rating and therefore is useful in increasing the octane level of unleaded gasoline. The fuel system components of your Mercury engine(s) have been tested to perform with the maximum level of ethanol blended gasoline (10% ethanol), currently allowed by the EPA in the United States.

Special precautions should be considered with the use of fuel containing ethanol in your system. Fuels with ethanol can attack some fuel-system components, such as tanks and lines, if they are not made from acceptable ethanol-compatible materials. This can lead to operational problems or safety issues such as clogged filters, leaks, or engine damage.

Your boat was manufactured, and shipped from the factory with ethanol compatible materials. Before introducing petrol with ethanol into your fuel tank, ask your dealer if any components have been added or replaced that are not recommended by Quicksilver, Mercury or may not be ethanol-compatible.

Filling The Tank

It is best to maintain a full tank of fuel when the engine is not in use. This will reduce the air flow in and out of the tank due to changes in temperature as well as limiting exposure of ethanol in the fuel to humidity and condensation.

When filling the tank, do not attempt to top off the tank. When the nozzle shuts off, the tank is full, and continuing to fill past the fuel fill shutoff will cause the system to spit fuel back.

⚠ DANGER

Petrol vapors can explode. Never smoke while handling or filling up the petrol tank. Leaking fuel is a fire and explosion hazard. Inspect the fuel system annually to make sure that there are no leaks and corrosion in the system.

⚠ WARNING

Do not store any equipment containing petrol (outboard engines, portable petrol tanks, etc.) in any cockpit storage areas. These compartments were not designed to store petrol and do not have adequate ventilation.

Phase Separation

Humidity and condensation create water in your fuel tank which can adversely effect the ethanol blended fuel. A condition called phase separation can occur if water is drawn into the fuel beyond the saturation point. The presence for water in the fuel beyond the saturation level will cause most of the ethanol in the fuel to separate from the bulk fuel and drop to the bottom of the tank, significantly reducing the level of ethanol in the fuel mixture in the upper level (phase). If the lower level (phase), consisting of water and ethanol, is deep enough to reach the fuel inlet, it could be pumped directly into the engine(s) and cause significant problems. Engine problems can also result from the reduced ethanol/fuel mixture left in the upper phase of the tank.

Additives

There is no practical additive known that can prevent or correct phase separation. The only solution is to keep water from accumulating in the tank. If phase separation does occur, your only remedy is to drain the fuel, clean and dry the tank completely and refill with a fresh, clean tank of fuel.

Quicksilver 605PH — System & Component Overview and Operation

Fuel Filters

Mercury already provided the appropriate level of filtration to protect the engine from debris. The addition of another in-line filter to the system will create a possible flow restriction that can starve the engine of fuel. As a precaution, it is advisable to carry extra on-engine filters in case filter plugging from debris becomes a problem during boating.

Maintenance

Periodically inspect for the presence of water in the fuel tank. If any is found, all water must be removed and the tank completely dried before refilling the tank with any fuel containing ethanol.

Storage

Long periods of storage and/or non-use, common to boats, create unique problems. When preparing to store a boat for extended periods, of two months or more, it is best to completely remove all fuel from the tank. If it is not possible to remove the fuel, maintaining a full tank of fuel with a fuel stabilizer added to provide fuel stability and corrosion protection is recommended.

REFER TO THE ENGINE MANUFACTURER'S MANUAL IN YOUR OWNER'S MANUAL PACKAGE FOR COMPLETE INSTRUCTIONS AND WARRANTY INFORMATION.

⚠ CAUTION

E85 FUELS COULD SERIOUSLY DAMAGE YOUR ENGINE AND MUST NEVER BE USED.

⚠ CAUTION

The use of fuels containing ethanol higher than 10 percent (E-10) can damage your engine and/ or fuel system and will void the warranty.

⚠ WARNING

Do not obstruct or modify the ventilation system.

2. Bilge Pumps

Your vessel is equipped with two bilge pumps, with one located in the aft section of the boat, and the second one located in the forward section of the boat. Access to the aft bilge pump is via the motorwell access plate, while access to the forward bilge pump is through the interior floor liner aft hatch. Both bilge pumps are rated for 500 GPH, and are activated automatically by a built in mercury free float switch when the water in the bilge reaches a predetermined level. You can also manually operate the bilge pump at the console by pressing the bilge pump switch.

Inspect the bilge pump intake and keep it free of dirt or material which may impede the flow of water through the pump. To clean the pump strainer, depress the lock tabs on both sides of the pump and lift the pump motor.

If water does not come out of the discharge hose:

1. Remove the motor module to see if the impeller rotates with the power on.
2. Remove any debris that may have accumulated in the nozzle section or strainer base.
3. Check hose and connection on hull side for debris and proper connections.

⚠ WARNING

The bilge pumping system is not designed for damage control.

NOTICE

Check the function of all bilge pumps at regular intervals. Clear pump inlet from debris.

Quicksilver 605PH — System & Component Overview and Operation

Typical Bilge Pump System

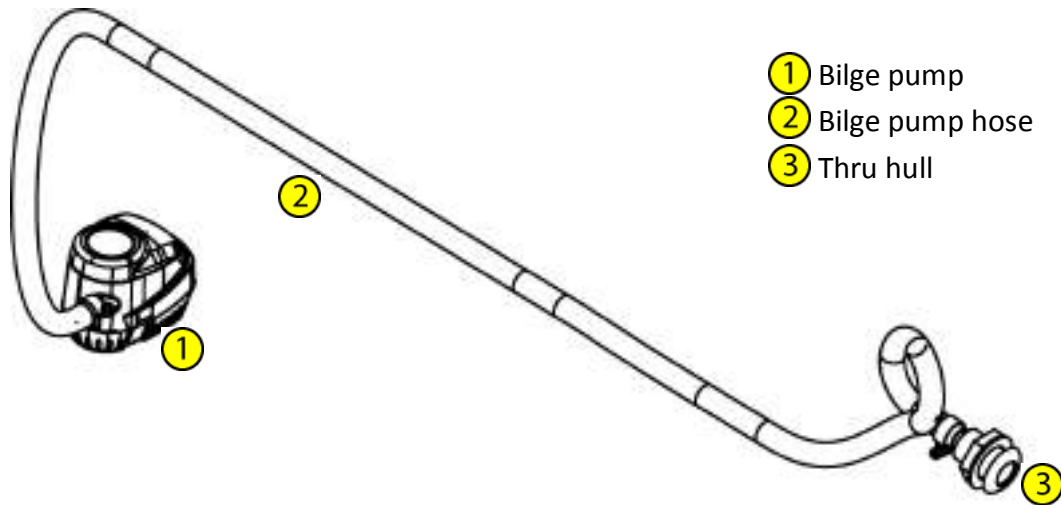

3. Livewell/Raw Water Washdown (optional)

An optional livewell and raw water washdown system is available for this boat. If installed, a 31 liter livewell is located on the port aft side of the cockpit under the seat, while the raw water washdown is located on the port forward step. The livewell is used to keep baitfish alive by circulating seawater through the tank.

Livewell Operation

Before operating the system, make sure that the livewell / raw water pickup valve is in the open position. The livewell / raw water pickup valve can be accessed through the motorwell access plate. To fill the livewell, press the switch marked “LIVEWELL” on the fish pack switch panel located under the port coaming cap. Inside the livewell, there is an aerator spray head that allows you to control the flow of water. To increase the flow of water, turn the spray head counterclockwise, while turning the spray head clockwise decreases the flow. Located in the center of the livewell, there is a drain tube which allows excess water to flow overboard, and fresh seawater to continually circulate. To drain the livewell, simply unscrew the drain tube.

Raw Water Washdown Operation

Before operating the system, make sure that the livewell / raw water pickup valve is in the open position. To operate, press the switch marked “RAW WATER WASHDOWN” on the fish pack switch panel located under the port coaming cap. This activates a 4.0 GPM pump that supplies water to the washdown sprayer.

Maintenance

Maintenance of the livewell and raw water washdown system will require you to check the fittings and hoses to make sure that there are no leaks. Check the in-line strainer attached to the pump and clean if necessary. If the system does require maintenance, contact your local dealer.

If you are storing the boat during the winter, we recommend you winterize the system.

To Winterize the Livewell & Raw Water Washdown System:

1. Drain the water out of all of the hoses in the livewell & raw water washdown system.
2. Remove the sprayer from the raw water washdown hose and drain the water out of the hose.

Quicksilver 605PH — System & Component Overview and Operation

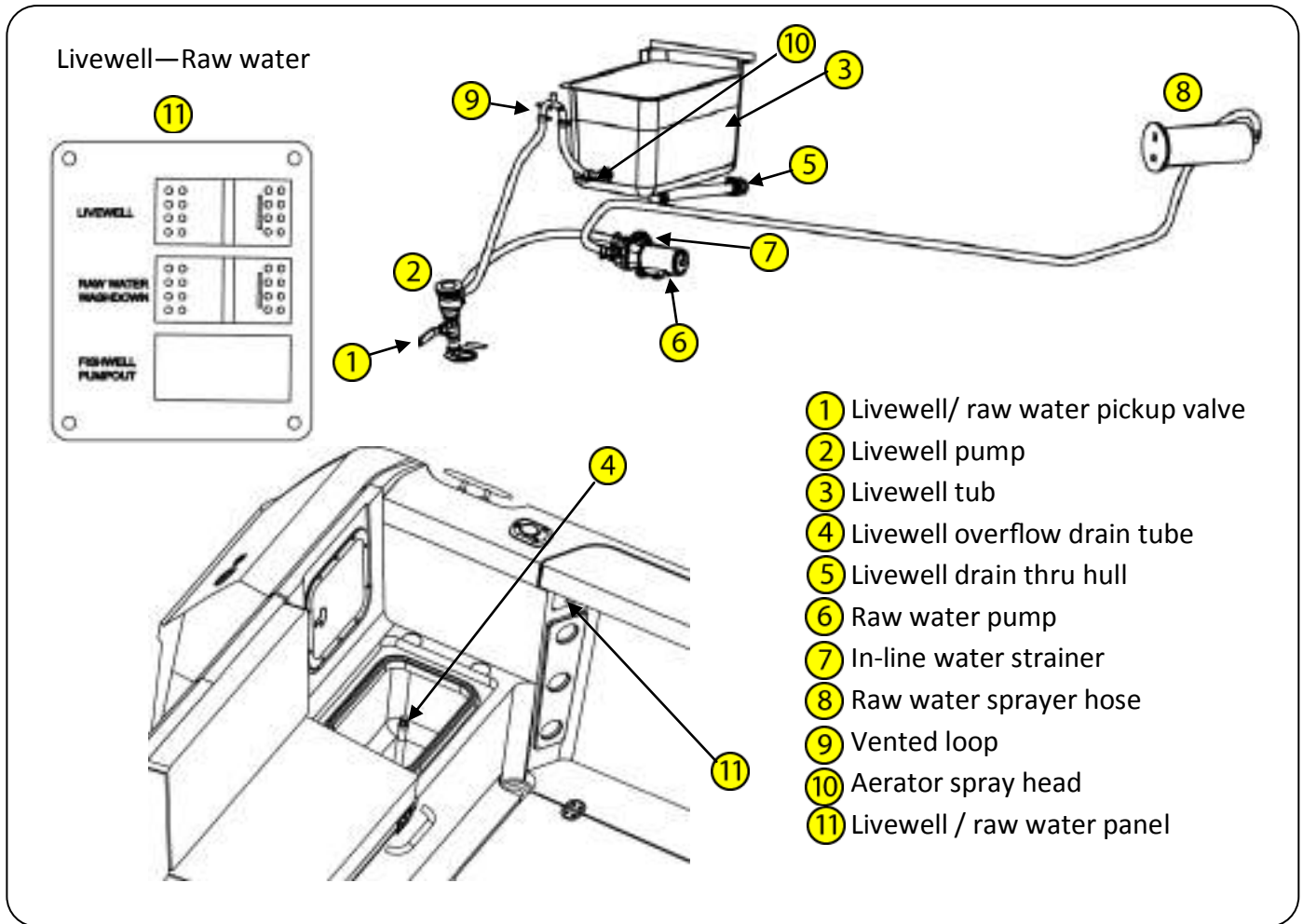

4. Fish Boxes

Your boat has two large fish boxes located in the port and starboard side of the cockpit. Each fish box has a drain plug that allows for the discharge of water from the compartment.

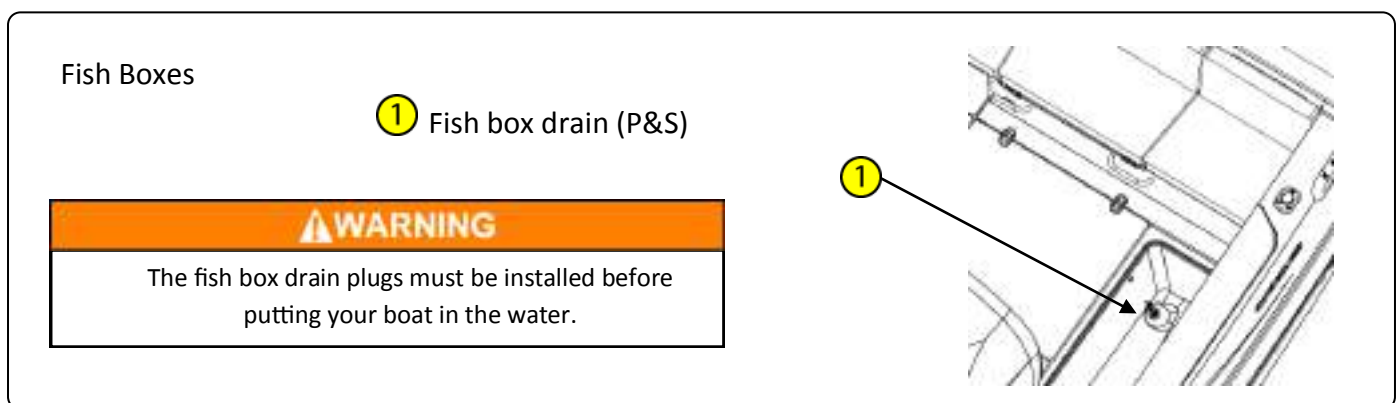

5. Fire Prevention

Fire is a serious boating hazard. Boats will burn quickly. Do not remain onboard and fight a fire for more than a few moments. If the fire is out of control and cannot be put out with the fire suppression equipment onboard, abandon ship immediately.

The boat, when in service shall be equipped with the following portable fire extinguisher:

1. Fire Rating 13A 89B C

Quicksilver 605PH — System & Component Overview and Operation

The boat owner/operator shall:

1. Have the fire fighting equipment checked at the intervals indicated on the equipment.
2. Replace portable fire extinguisher, if expired or discharged, by devices of identical fire fighting capacity.
3. Have fixed systems refilled or replaced when expired or discharged.
4. Ensure that the fire fighting equipment is readily accessible when the boat is occupied.
5. Inform the members of the crew about the location and operation of the fire fighting equipment, the locations of discharge openings in to the engine space, and the locations of escape routes and exits.
6. Keep the bilges clean and check for fuel and gas vapors or fuel leaks frequently.

WARNING

Never obstruct passageways to exits or hatches, safety controls (fuel valves, LPG valves, electrical switches, etc.), portable fire extinguishers stowed in lockers, or modify any of the craft's system (especially fuel, LPG, or electrical) or allow unqualified personnel to modify any of the craft's system.

The fire extinguisher is located inside the cabin by the entry door on the helm seat base, while the fire port is located on the vertical wall of the cockpit aft bench seat .

Fire Extinguisher

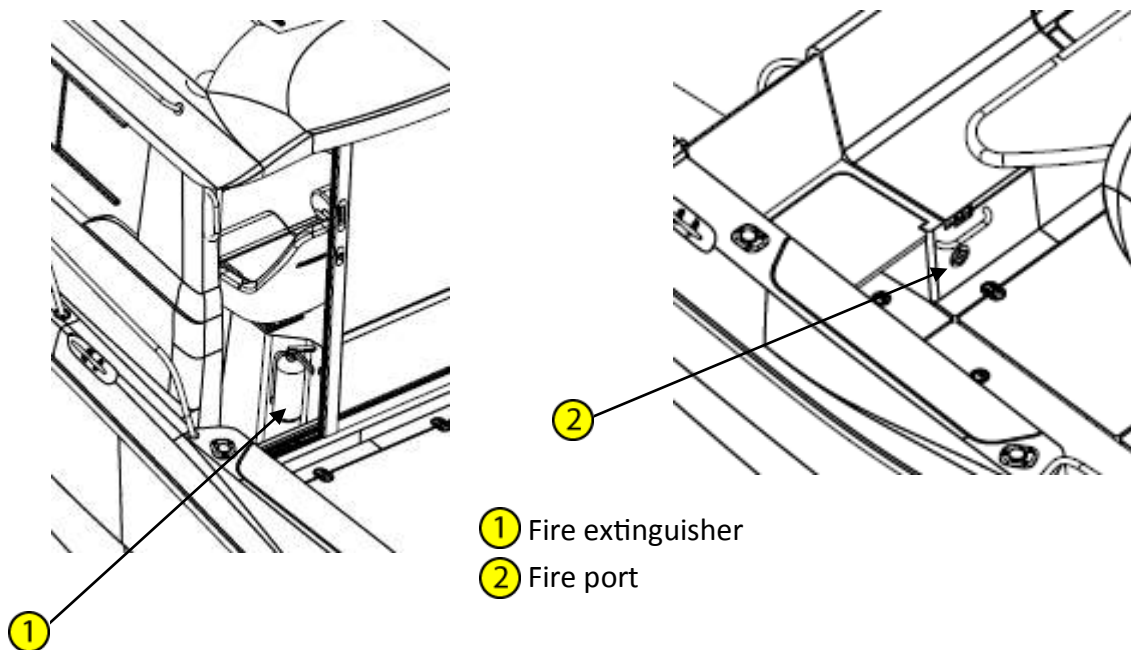

6. Carbon Monoxide Monitor

Quicksilver® boats are equipped with carbon monoxide (CO) monitors in the cabin and enclosed berths or staterooms. Carbon Monoxide is an odorless, colorless, tasteless, and extremely toxic gas produced by engines, heaters, stoves or generators. When inhaled it combines with hemoglobin in the blood, preventing absorption of oxygen and is unlikely to be noticed until the person is overcome. Prolonged exposure to low concentration or very short exposure to high concentrations can result in asphyxiation and death.

Quicksilver 605PH — System & Component Overview and Operation

Symptoms of Carbon Monoxide poisoning include dizziness, headaches, ringing in the ears, nausea, or unconsciousness. GET MEDICAL ATTENTION AS SOON AS POSSIBLE. These symptoms are often confused with seasickness or intoxication, so those affected may not receive the medical attention they need. The poisoning victim's skin often turns cherry red. If CO poisoning is suspected, have the victim breath fresh air deeply. If breathing stops, resuscitate. A victim often revives, then relapses because organs are damaged by lack of oxygen.

Carbon Monoxide Accumulation & Prevention

Carbon Monoxide can accumulate in dangerous concentrations anywhere in or around your boat including on back decks, swim platforms, or in water around generator exhausts. CO can remain in or around your boat at dangerous levels even if your engine is no longer running. To minimize the risk of Carbon Monoxide poisoning, consider the following:

- Make sure that at all times, there is good ventilation throughout the boat. Open all hatches, portlights, or canvas openings to let fresh air circulate.
- Never operate the boat with the canvas enclosure unless there is ventilation throughout the boat (i.e. forward and aft canvas panels are removed to allow air flow through the boat).
- Never operate the boat with only the cabin entry door opened.

In the event that the Carbon Monoxide alarm activates:

- Do not ignore the alarm.
- Evacuate enclosed areas immediately.
- Shut OFF any fuel burning equipment or appliances
- Open hatches, doors, portlights and canvas openings to improve ventilation.
- Head the boat into the wind.

Accumulation of Carbon Monoxide Examples

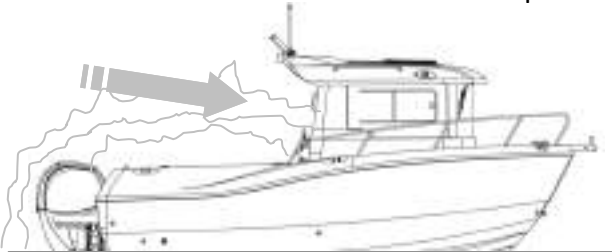

Wind blowing exhaust towards boat occupants

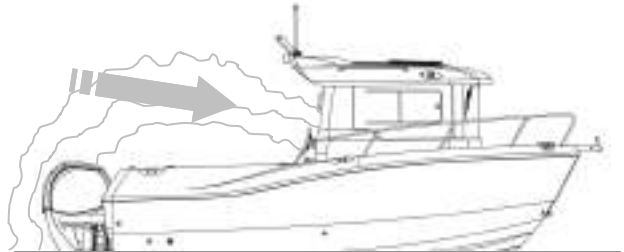

Operating at slow speed or dead in the water

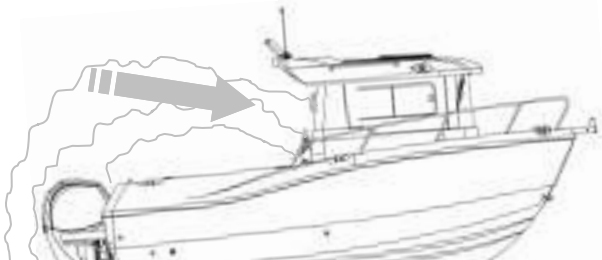

Operating with "bow high" attitude

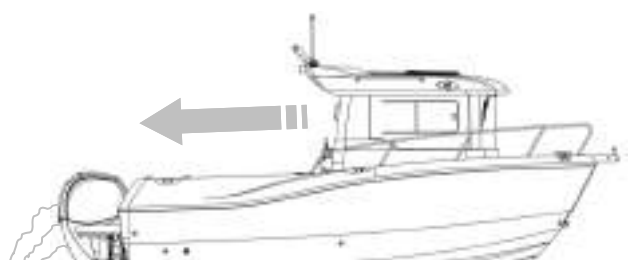

Good air flow — open all hatches, portlights or canvas openings to let fresh air circulate

Carbon Monoxide Monitor

The CO monitor is an electronic instrument that detects carbon monoxide. The detector is very sensitive and will notify you before dangerous amounts of CO can accumulate which will allow you to take measures to dissipate the gas from the affected areas. When there is a buildup of CO in the

Quicksilver 605PH — System & Component Overview and Operation

cabin, the monitor will alert the occupants by flashing a DANGER light and sounding an alarm. The CO monitor is powered through a breaker on the battery panel in the cockpit.

It is important that you read and understand the CO monitor information and operating instructions. It is extremely important that you become familiar with the CO monitor and its functions.

Testing the CO Monitor

Test the monitor on your boat at manufacturers required intervals by pushing the TEST button on the side of the unit. If the unit is operating correctly both audible and visual warning indicators will be activated.

End of Life Signal

Your CO detector may be equipped with an End Of Life (EOL) signal indicating the sensor used in the unit has reached the end of its service life and must be replaced. The signal is activated from a timer that will run for 4 years, 11 months from the date of manufacture. Depending on your monitor, the EOL signal indicator varies, so check the unit's operation manual for further information and instructions.

The EOL signal can be reset for a period of 72 hours (3 days) for a total of up to 30 days. After this time, the unit will continuously signal EOL and will no longer detect CO and **MUST BE REPLACED! DO NOT DISCONNECT THE ALARM UNTIL YOU HAVE A REPLACEMENT ALARM AVAILABLE TO INSTALL! REMOVING THE LITHIUM BATTERY WILL CAUSE THE UNIT TO SIGNAL EOL PERMANENTLY!**

REFER TO OWNER'S MANUAL PACKAGE FOR INSTRUCTIONS AND WARRANTY INFORMATION.

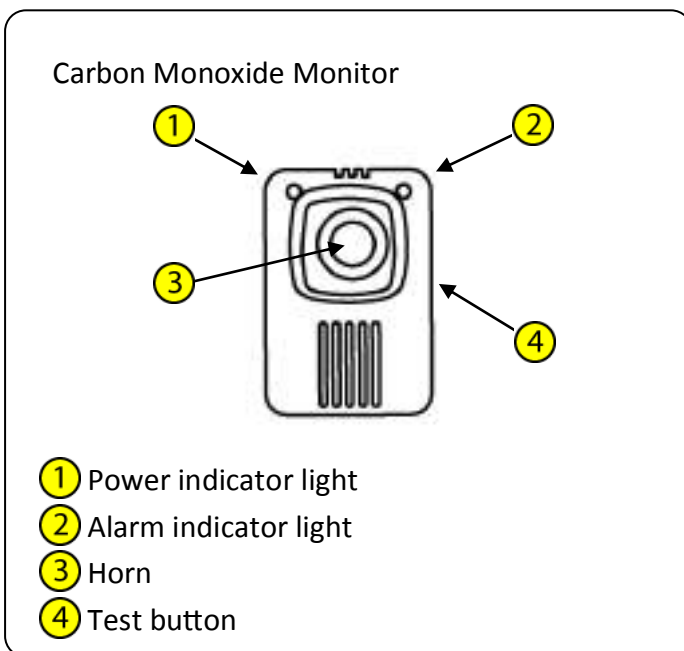

⚠ DANGER

Fumes for the engine(s), generator, LPG stoves, and other equipment that burns fuel contain Carbon Monoxide. Carbon Monoxide can kill you. Open all doors, hatches, curtains, and windows to allow fresh air to circulate.

⚠ DANGER

Never ignore an alarm.

⚠ CAUTION

To reduce the risk of Carbon Monoxide poisoning, test the monitor operation when not in use for 10 days or more.

7. Bow Anchor Windlass (optional)

The anchor windlass located at the bow of the boat assists with the anchoring of your boat by automatically raising and lowering the anchor. The windlass is operated from the helm.

Operation

To operate the windlass, the windlass breaker, located next to the battery, must be turned ON. Operation of the windlass at the helm is controlled by a momentary switch used to raise and lower the anchor. Pushing down on the switch will lower the anchor, while pushing up on the switch raises the anchor.

Quicksilver 605PH — System & Component Overview and Operation

Manual operation

In the event that there is a loss of power, the windlass can still be used to raise or lower the anchor manually. If there is a loss of power, check the windlass breaker to see if it needs to be reset. If you reset the breaker and it continues to trip, have your authorized Quicksilver® dealer inspect the system.

In order to manually operate the windlass and lower the anchor into the water, insert the emergency handle (provided by the windlass manufacturer) into the star socket located at the top of the gypsy cover and turn counter-clockwise. This loosens the clutch holding the anchor rode and chain in place and allows the anchor to be deployed into the water. The speed of the rode can be adjusted by turning the handle clockwise. To re-engage the clutch and lock the rode from moving, turn the handle clockwise.

To manually raise the anchor, loosen the clutch by turning the handle counter-clockwise, and pull the anchor up into the boat. Make sure to properly feed the rode and chain through the windlass when pulling up the anchor. When the anchor is up and stowed properly in the bow pulpit, re-engage the clutch by turning the handle clockwise.

REFER TO OWNER'S MANUAL PACKAGE FOR INSTRUCTIONS AND WARRANTY INFORMATION.

Anchor Windlass

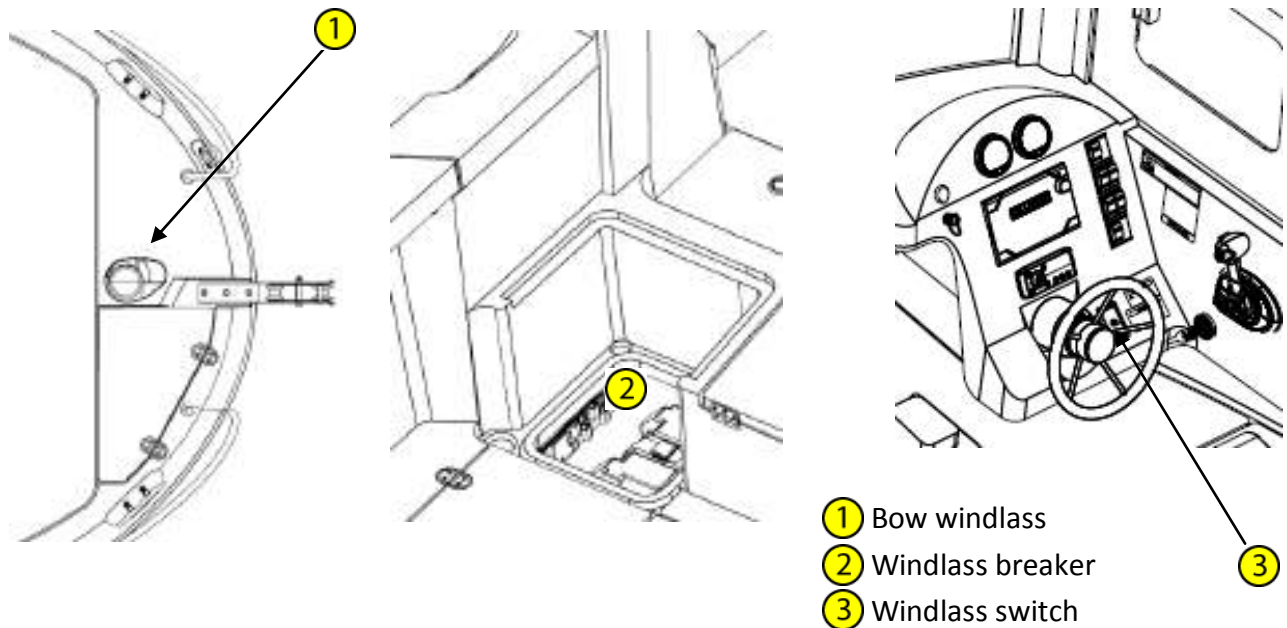

NOTICE

Before operating the windlass, make sure that the safety lanyard is removed from the anchor

8. Steering

Your boat comes equipped with a hydraulic steering system. The basic system for a single engine boat contains a steering wheel, a hydraulic helm pump, a hydraulic steering cylinder, and hydraulic hoses.

Operation

When turning the steering wheel, the helm pump forces hydraulic fluid through hoses to and from the steering cylinder which is connected to the tiller arm on the engine. The cylinder moves the tiller arm to either port or starboard, depending upon the direction the steering wheel is turned.

Quicksilver 605PH — System & Component Overview and Operation

Filling and Maintenance

A hydraulic steering system rarely needs to be refilled after the system is bled. However, if you ever need to add fluid to the system, refer to the steering manufacturer's manual for complete instructions. The fill point is located on the helm itself, in front of the steering wheel.

REFER TO OWNER'S MANUAL PACKAGE FOR INSTRUCTIONS AND WARRANTY INFORMATION.

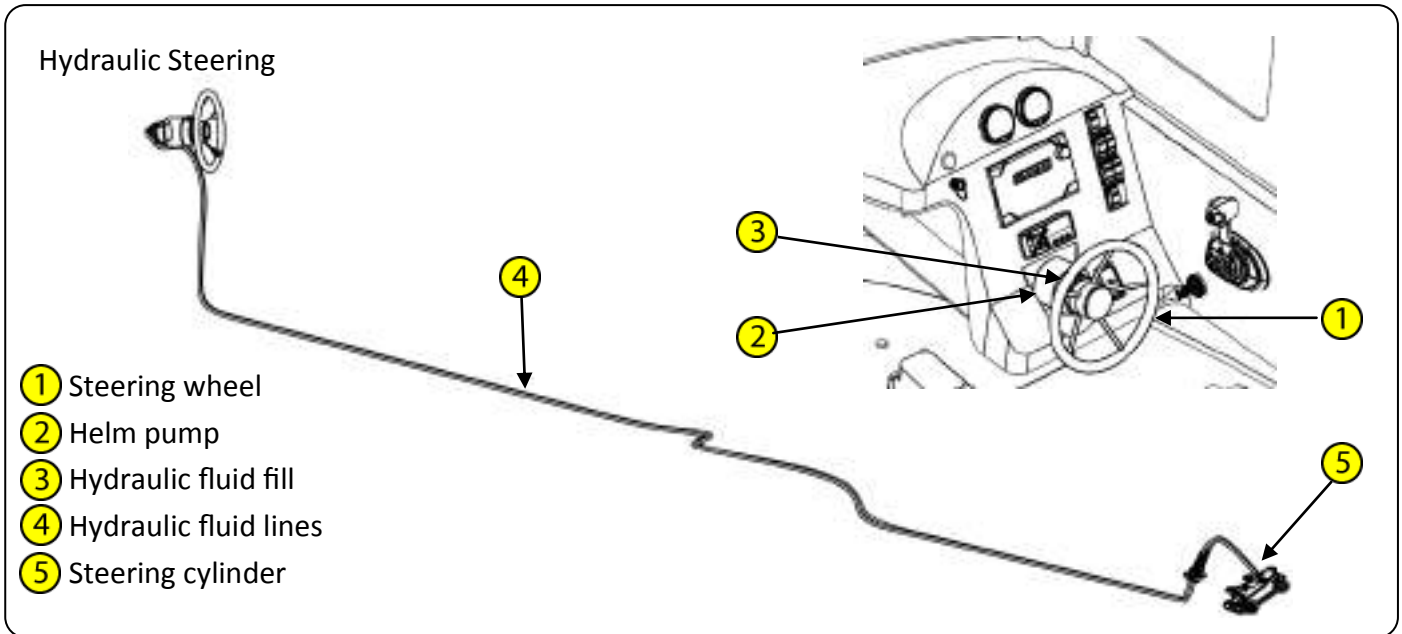

9. Engine Controls

Your boat comes with a mechanical gear shift/throttle control unit, located to the starboard of the steering wheel, which activates both the shifting and throttle for the engine.

To start the engine, the control unit must be in the NEUTRAL position. When in neutral, the engine is running, but the propeller is not spinning. There is a throttle only button that when pressed, will allow you to operate the throttle without the propeller spinning. On the mechanical shift controller, the button is located at the center of the throttle control, and when moved back to the center position, the button will automatically re-engage the shifting mechanism.

Moving the control lever forward from neutral engages the forward gear and thrust. Moving the control lever backwards from neutral engages the reverse gear and thrust. The throttle lever controls the RPM of the engine and the speed of the boat.

Power Trim & Tilt

The power trim, located on the side of the gear shift throttle handle, allows you to raise and lower the engine for trailering and launching the boat. It also allows you to adjust the engine to create the optimum run angle for the boat to achieve best all around performance (fuel consumption, speed).

REFER TO OWNER'S MANUAL PACKAGE FOR INSTRUCTIONS AND WARRANTY INFORMATION.

10. Emergency Engine Shutdown Switch

Your boat is equipped with an ignition shutdown safety switch built into the engine control. The ignition shutdown switch incorporates a shut-off switch and a lanyard. Before operating the boat, one end of the lanyard must be connected to the shut-off switch while the other end is connected to the operator. If an emergency arises where the engine must be shut down, pull the lanyard cord to

Quicksilver 605PH — System & Component Overview and Operation

release it from the shut-off switch, which in turn shuts down the engine. This switch is designed to shut the engine off when the operator of the boat leaves the control station, either accidentally by falling into the boat, or by being ejected overboard.

The lanyard should be long enough to prevent inadvertent activation. Do not let the lanyard become entangled.

Mechanical Control

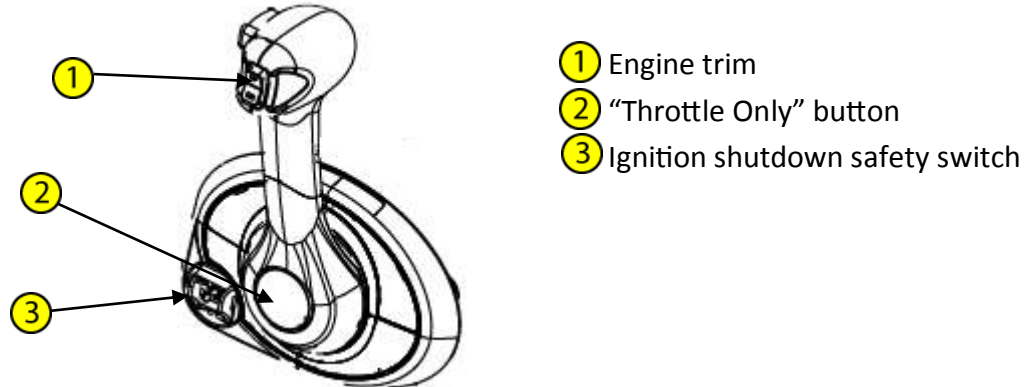

WARNING

Wear the lanyard at all times when operating the boat. Use it to stop the engine only in an emergency. DO NOT use it to shut off the engine during normal operation

11. SmartCraft® System Gauges

The instrument package on your boat includes a SmartCraft® tachometer and speedometer multi-gauge system. By pressing the “mode” button on the gauge, specific information vital to the safe operation of the vessel can be displayed. Refer to your SmartCraft® gauge owner’s manual for specific information on how to get the most out of the multi-gauge display.

12. Exterior Helm (optional)

An optional exterior helm is available which allows for low speed operation of your boat while in the cockpit. The exterior helm, located on the forward starboard side of the cockpit consists of a steering wheel, a hydraulic helm pump, and a mechanical gear shift/throttle control unit. In addition, the gear & throttle mechanisms are located in the cockpit bilge, and a helm selector switch is located at the main helm.

Operation

At the main helm (located inside the cabin) there is a helm selector switch located on the starboard side, under the control unit. The helm selector switch mechanically “locks out” the control unit to make sure that you can only control the engine from one helm. The gear & throttle mechanisms are located in the cockpit bilge.

Helm Control Transfer

When the switch is in horizontal position, the control is set to be at the main helm. To switch control from the main helm to the exterior helm, pull out and rotate the handle clockwise 90 degrees until it locks into position. You will now have control of the engine at the exterior helm. To return control back to the main helm, pull out and rotate the handle counter-clockwise 90 degrees until it locks into position.

Quicksilver 605PH — System & Component Overview and Operation

The steering system is independent of the helm selector switch and will operate at all times. **DO NOT TURN THE STEERING WHEEL AT THE HELM THAT DOES NOT HAVE FULL CONTROL OF THE BOAT!**

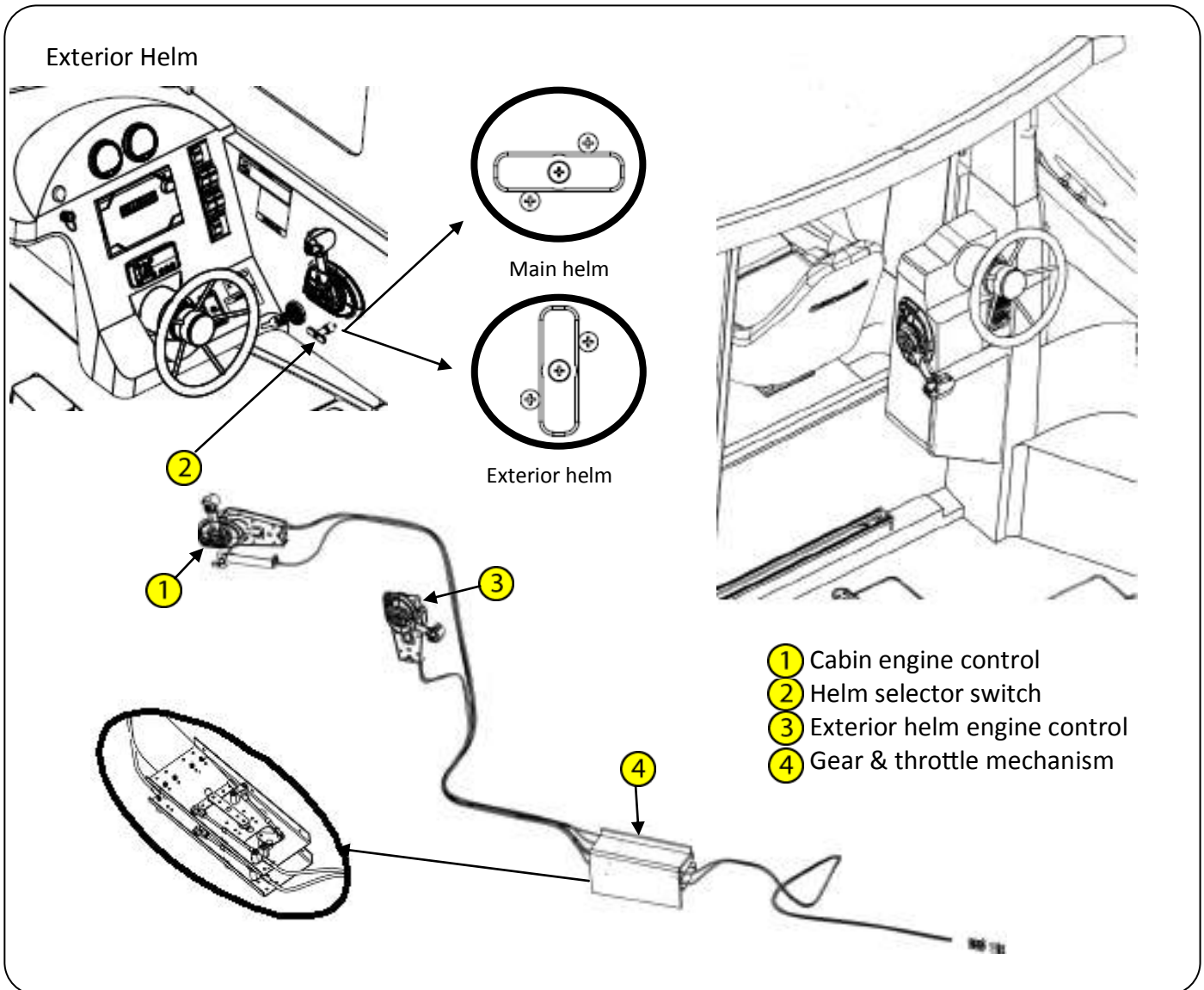

Hydraulic Steering

The exterior helm comes with an additional steering helm, steering wheel, and steering hoses that connects to the base steering system. The operation of the system is similar, where when you turn the steering wheel the helm pump forces hydraulic fluid through hoses to and from the steering cylinder which is connected to the tiller arm on the engine. Even though the helms are connected, the steering wheels will not rotate together when one wheel is turned.

Maintenance

A hydraulic steering system rarely needs to be refilled after the system is bled. However, if you ever need to add fluid to the system, refer to the steering manufacturer's manual for complete instructions.

REFER TO OWNER'S MANUAL PACKAGE FOR INSTRUCTIONS AND WARRANTY INFORMATION.

Quicksilver 605PH — System & Component Overview and Operation

Dual Helm Hydraulic Steering

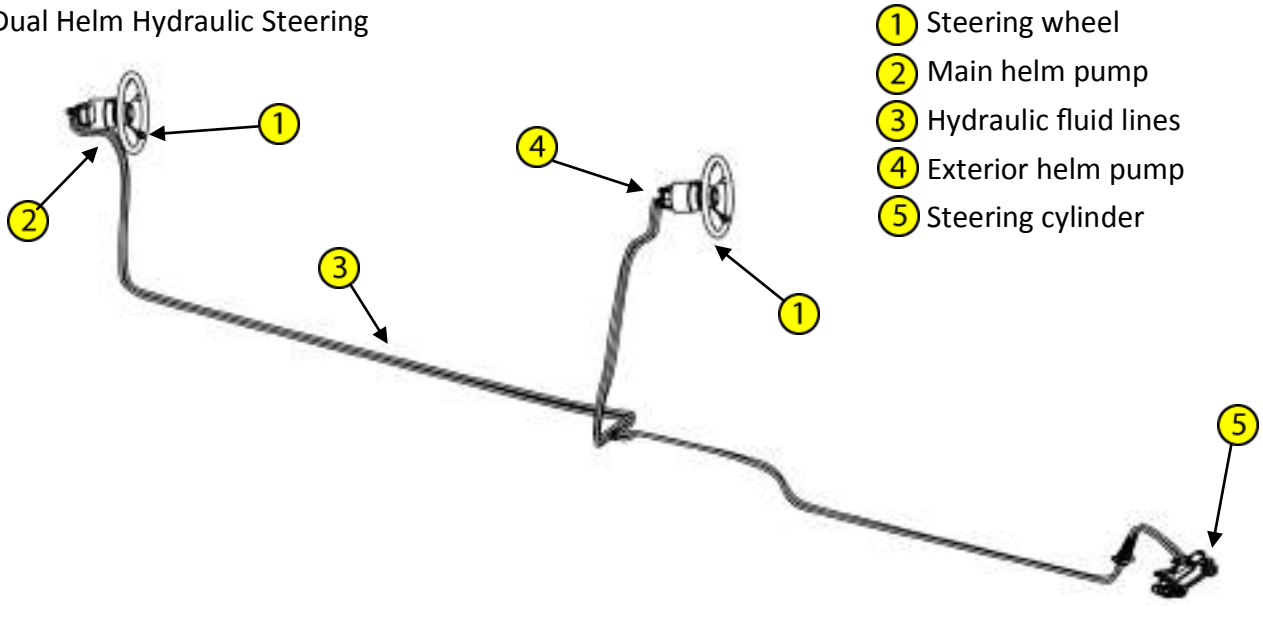

⚠ WARNING

Vision from the exterior helm station is limited. Maintain a lookout as required. Do not operate at planing speeds from the exterior helm.

⚠ WARNING

DO NOT TURN THE STEERING WHEEL AT THE HELM THAT DOES NOT HAVE FULL CONTROL OF THE BOAT.

13. Diesel Heat (optional)

The diesel heat system consists of a 3kW heater, a 10L diesel tank providing fuel for the heater, and a control panel that runs the system.

Operation

Prior to use, make sure that the diesel tank is full. The 10L diesel tank, located in the starboard bilge, can be accessed via the forward cockpit floor hatch. To fill the tank, first remove the strap holding the tank in place. Next, remove the cap with the fuel pickup and pull the tank out of the boat. ALWAYS FILL THE TANK OUTSIDE OF THE BOAT. When filled, re-install the cap, and secure the tank in the bilge.

The diesel heater is controlled by a keypad located inside the cabin by the starboard pilaster. The panel allows for either automatic control of a preset temperature, or it allows you to vary the blower speed and temperature manually. There are two heating ducts throughout the boat. First, there is a closable outlet located at the dash to defrost the windows for visibility. Next, there is a directional outlet located below the helm seats providing heat to the cabin area.

The heater pulls air from two locations; the first cold air inlet is located below the helm seat and the second is an exterior inlet located on the starboard side of the deckhouse. Finally, there is an exhaust outlet located on the starboard hullside where hot exhaust exits the unit.

REFER TO OWNER'S MANUAL PACKAGE FOR INSTRUCTIONS AND WARRANTY INFORMATION.

⚠ WARNING

Exhaust gas is HOT. Ensure that there is nothing that is susceptible to heat damage (i.e. ropes, fenders, other boats) within 200mm of the exhaust outlet.

Quicksilver 605PH — System & Component Overview and Operation

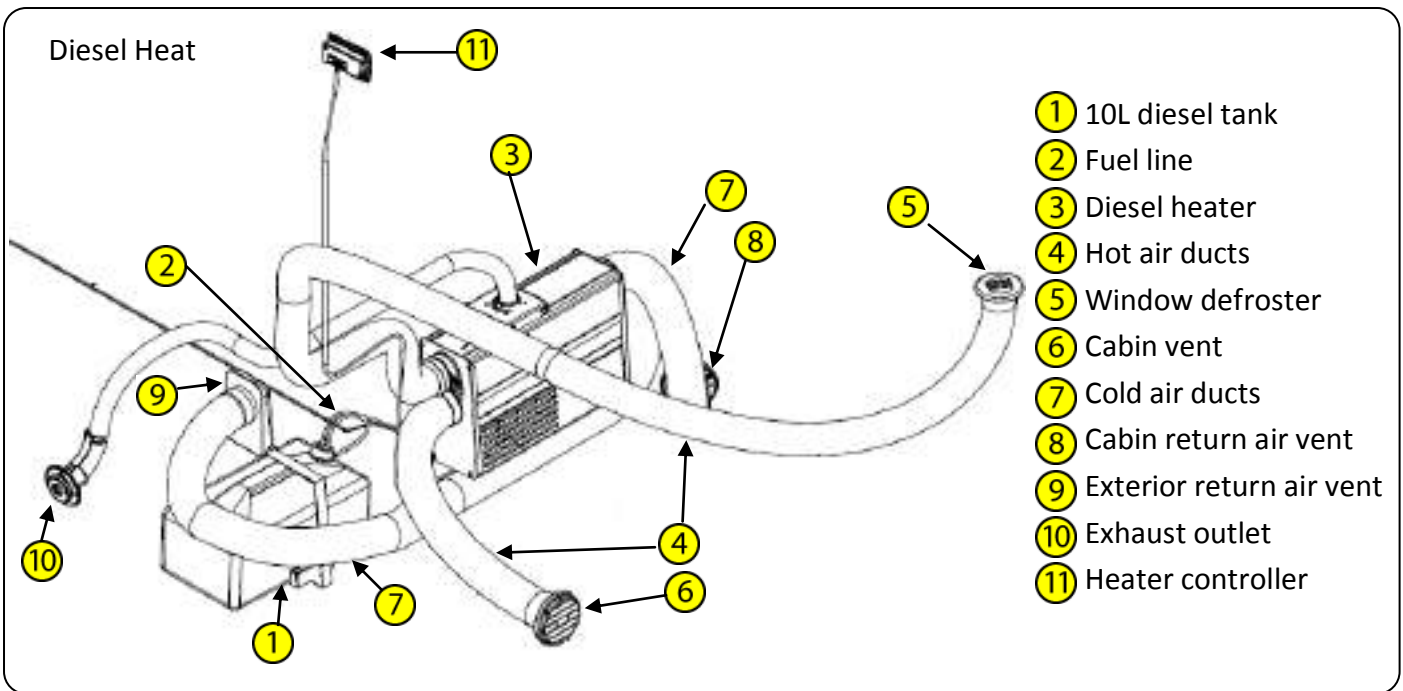

14. Stereo (optional)

Your boat may come equipped with a Fusion AM/FM stereo with Bluetooth®. The stereo unit along with a USB port, is located at the helm. The USB port allows you to connect an external music player for music playback through the boat's stereo. Alternatively, you can playback music via the Bluetooth® settings on your external music player.

There are four speakers on the boat, located on the hardtop.

REFER TO OWNER'S MANUAL PACKAGE FOR INSTRUCTIONS AND WARRANTY INFORMATION.

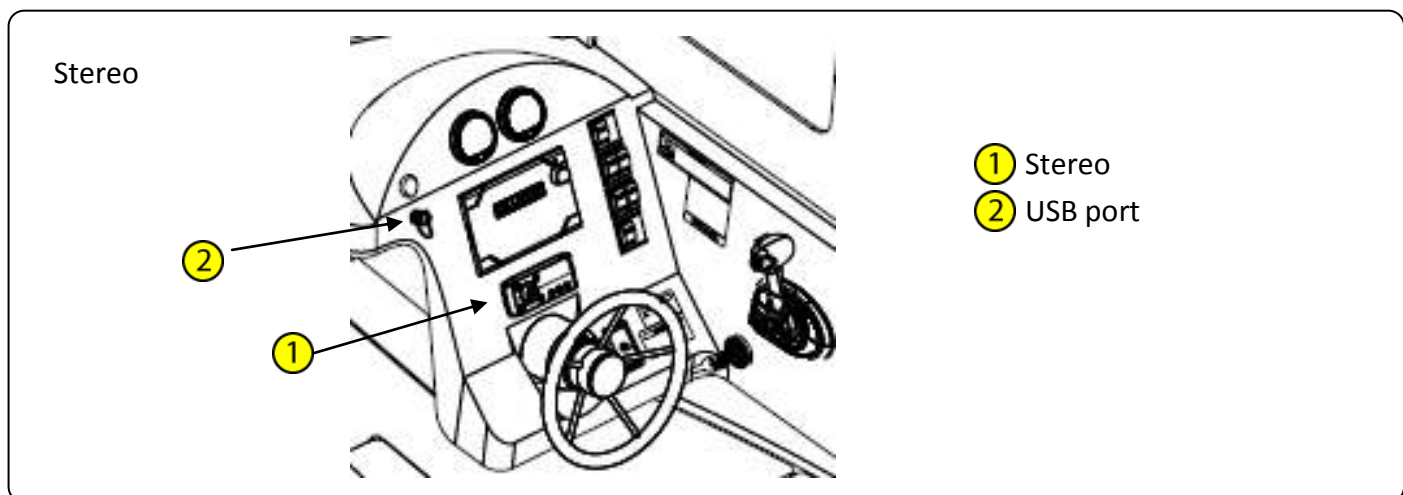

15. Windshield Wiper

Your boat is equipped with a windshield wiper system for use in inclement weather. To use, simply press the windshield wiper switch located at the helm. Pressing the switch to the forward position will turn the wiper on. Pushing the switch back will return the wiper to the park position.

16. Starboard Jump Seat

A starboard jump seat is included for additional aft seating. The base and cushion are removable to allow for easier entry in and out of the boat. To install the seat, set the base into the molded in self contained deck detail. Next, attach the cushion to the base.

Starboard Jump Seat

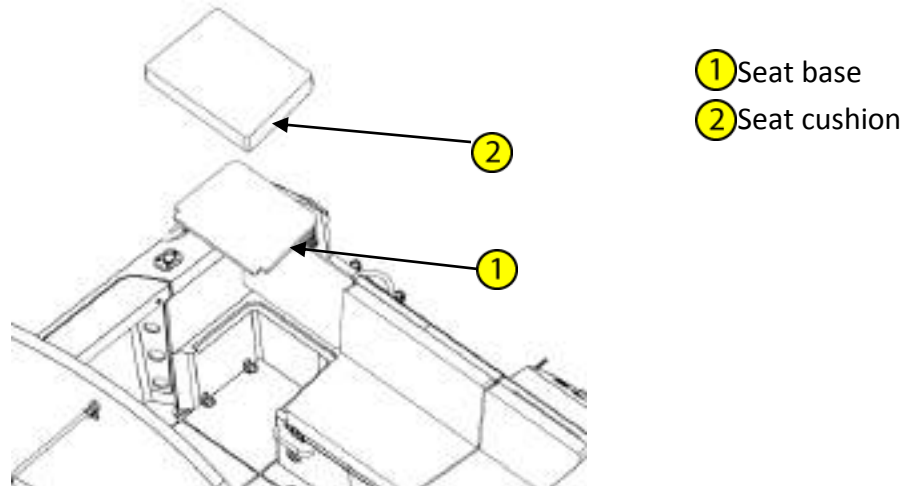

CAUTION

Before using, verify that the jump seat is properly installed

17. Cockpit Bench Seat

The cockpit bench seat increases the seating area by creating a continuous back bench at the aft end of the boat. When installed, the bench seat covers the motorwell, however, it does not interfere with normal operation and trimming of the engine. If you want to trim the engine to trailer position, the seat will rotate forward. Simply pull the seat back forward and it will move out of the way.

Cockpit Bench Seat

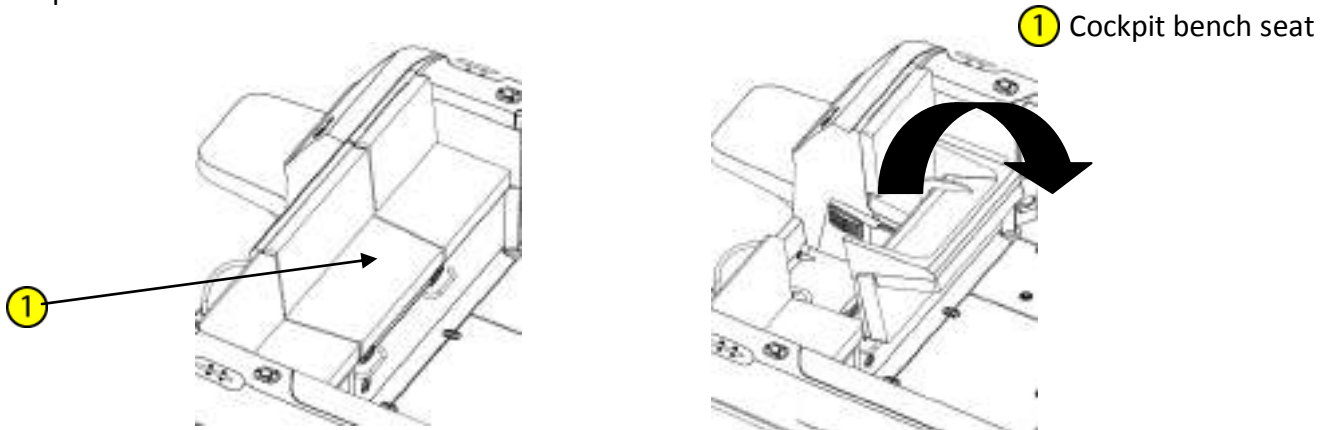

CAUTION

Before trimming the engine to trailer mode, make sure that the back bench filler is rotated forward. Failure to do so could cause damage to the engine and bench seat.

Quicksilver 605PH — System & Component Overview and Operation

18. Port Flip Seat (optional)

As an option your boat may come equipped with a flip seat, located on the port side of the cockpit. When not in use, it stores up out of the way in the port deck trail. To use, simply pull the rail located on the base of the seat out and down.

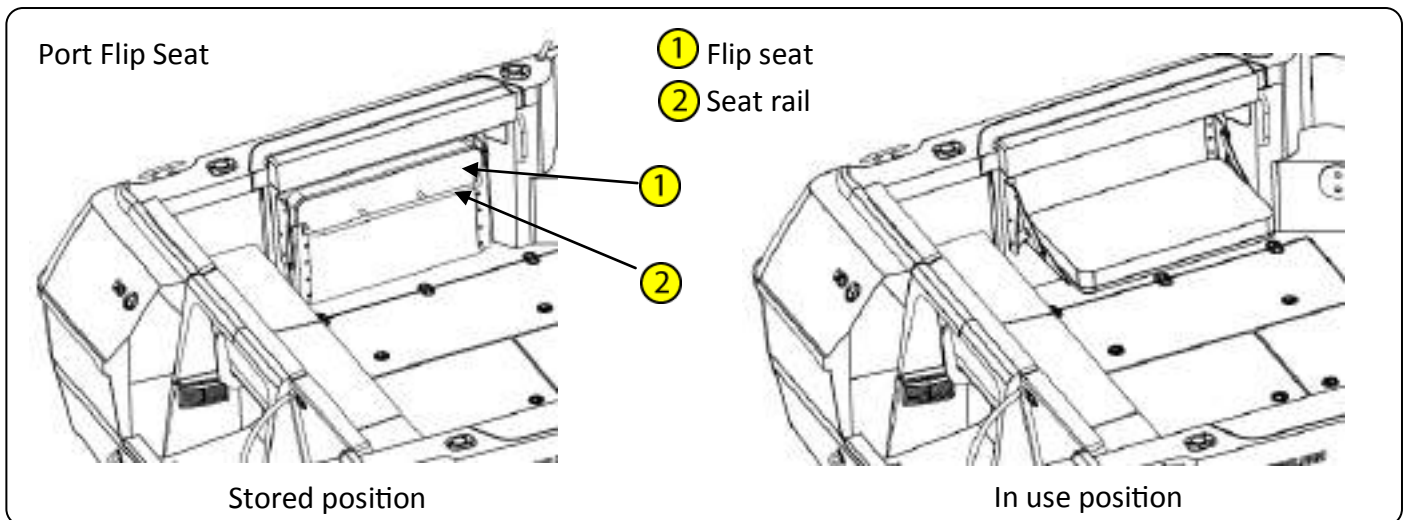

19. Cockpit Table

On your boat, a cockpit table is available for entertaining. The table and table leg is removable and can be stored inside the center cockpit hatches. To install the table, first remove the plastic cover located in the table base plate. Next, push and lock the table leg into the base plate. Finally, place the table onto the table leg.

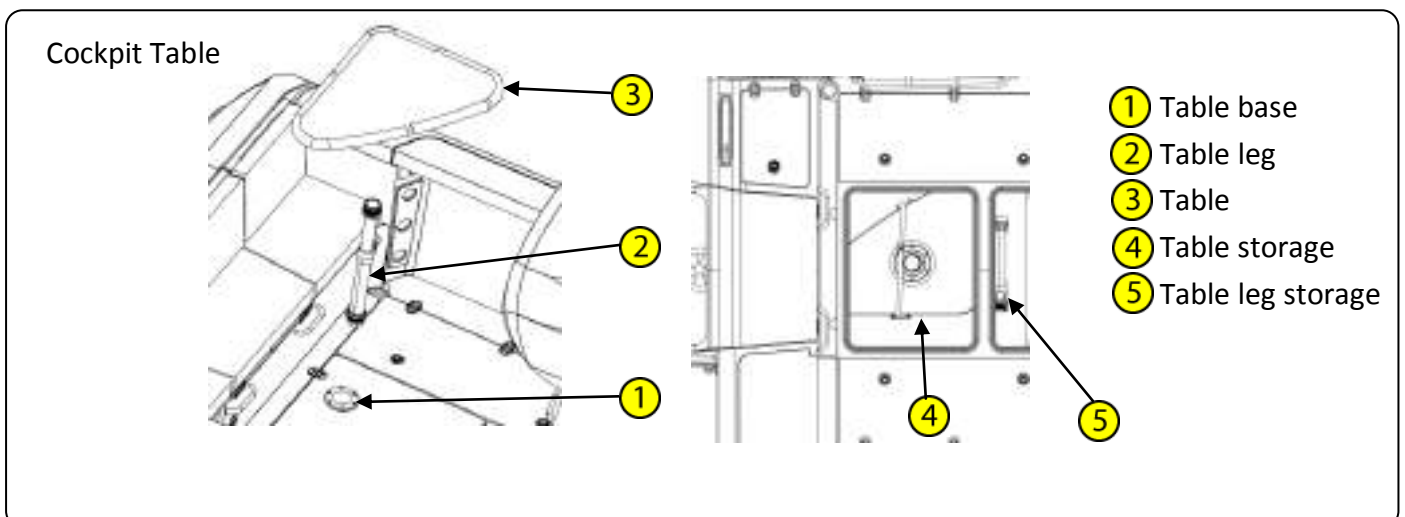

20. Sun Awning (optional)

If installed, an optional sun awning is available to provide protection from the sun. The sun awning consists of a rail in the hardtop and a canvas.

Operation

Within the hardtop rails (port and starboard), there is a pin that holds the awning rail in place. To extend the sun awning, simply push the pin on both sides and slide the rail out. The pins will re-engage and lock the rail when fully extended. To install the sun awning canvas, slide the welting (piping) located on front edge through the sun awning track installed on the hardtop. Next connect the canvas to the sun awning rail using the zippers on the edge of the canvas. Finally, connect the straps to the eyelets on the deck.

Quicksilver 605PH — System & Component Overview and Operation

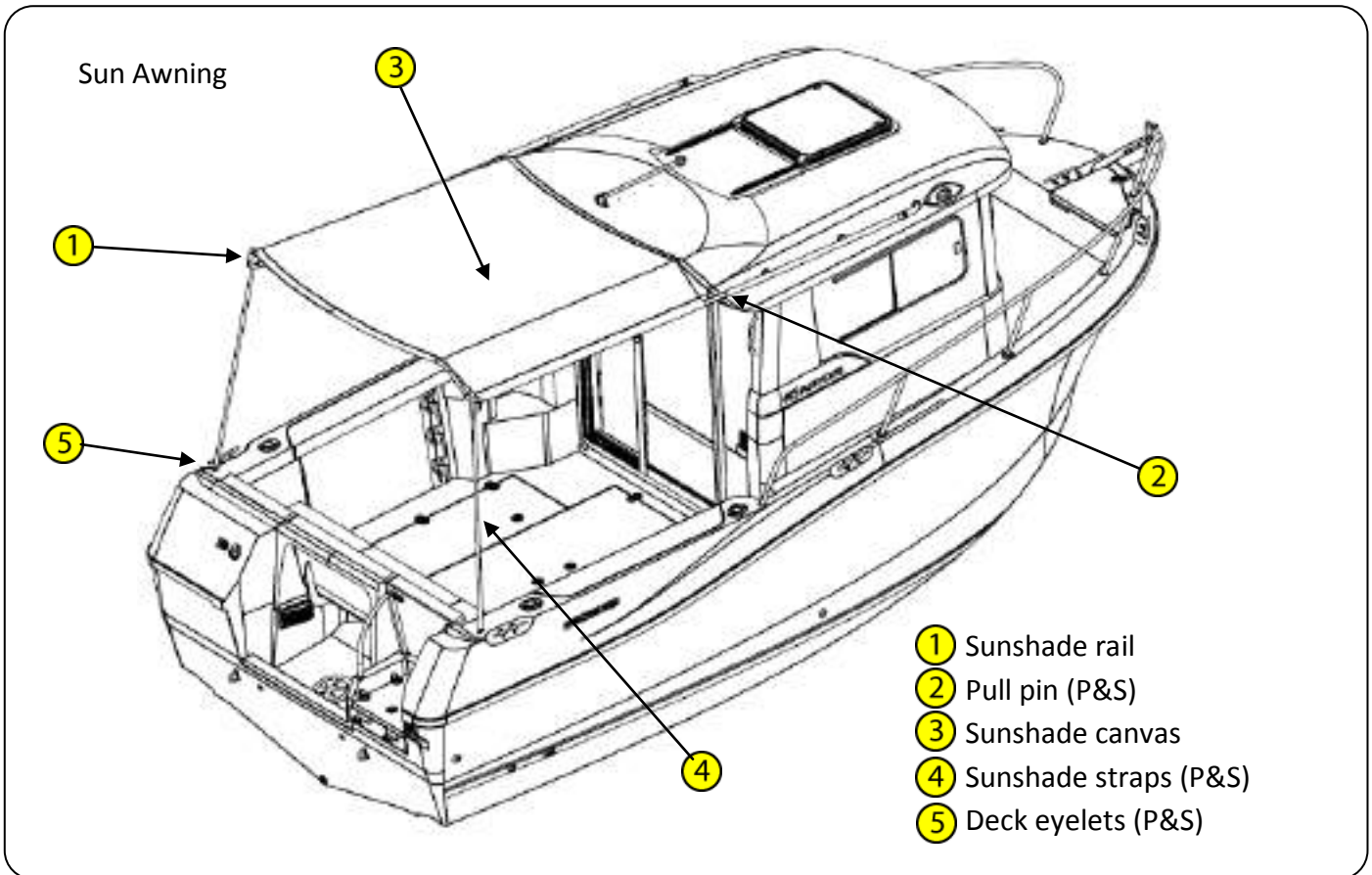

CAUTION

In rough seas, the sun awning should be stored to avoid damage to the rail and or canvas

21. Canvas (optional)

As an option, there is a bimini with frame and a bimini with vinyl panels that fully encloses the cockpit.

Bimini

When not in use, the bimini can be stored in an aft position where it does not interfere with the use of the boat. In this position, always make sure that the bimini is secured in the canvas boot. To use the bimini, remove the canvas boot and rotate the bimini frame forward and secure the canvas to the hardtop.

Bimini with Enclosure

In addition to the bimini, clear vinyl panels can be installed to enclose the cockpit. Each panel attaches to the bimini with a zipper and snaps or studs are used to attach to the deck.

NOTICE

NEVER TRAILER THE CANVAS BIMINI, BIMINI WITH ENCLOSURE, OR SUN AWNING IN THE UPRIGHT POSITION. The bimini canvas must be secured in the canvas boot with the rails in the stored position before trailering.

WARNING

NEVER OPERATE THE VESSEL WITH THE CANVAS ENCLOSURE UNLESS THERE IS VENTILATION THROUGHOUT THE BOAT. The forward and aft canvas panels must be removed to allow air flow through the boat so Carbon Monoxide cannot accumulate.

Quicksilver 605PH — System & Component Overview and Operation

Canvas

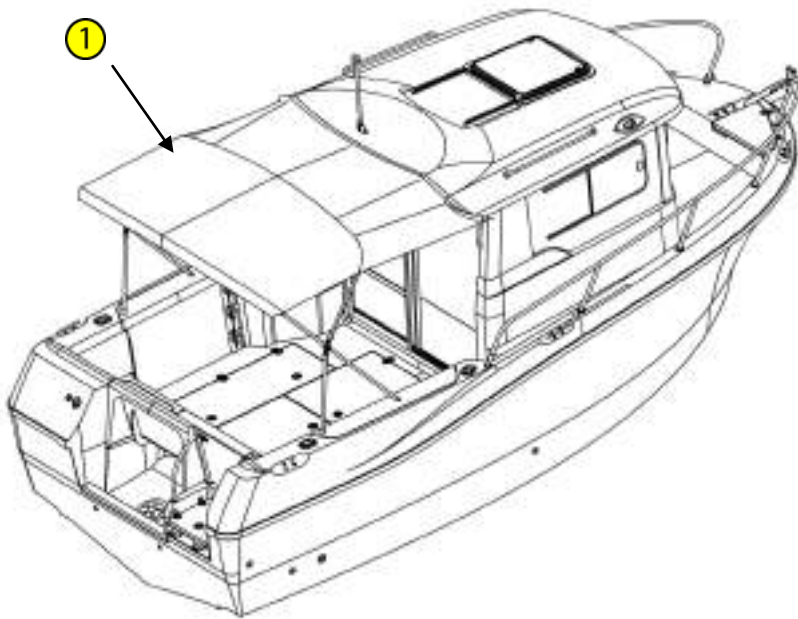

- ① Bimini
- ② Starboard enclosure panel
- ③ Port enclosure panel
- ④ Aft enclosure panel

Bimini Deployed

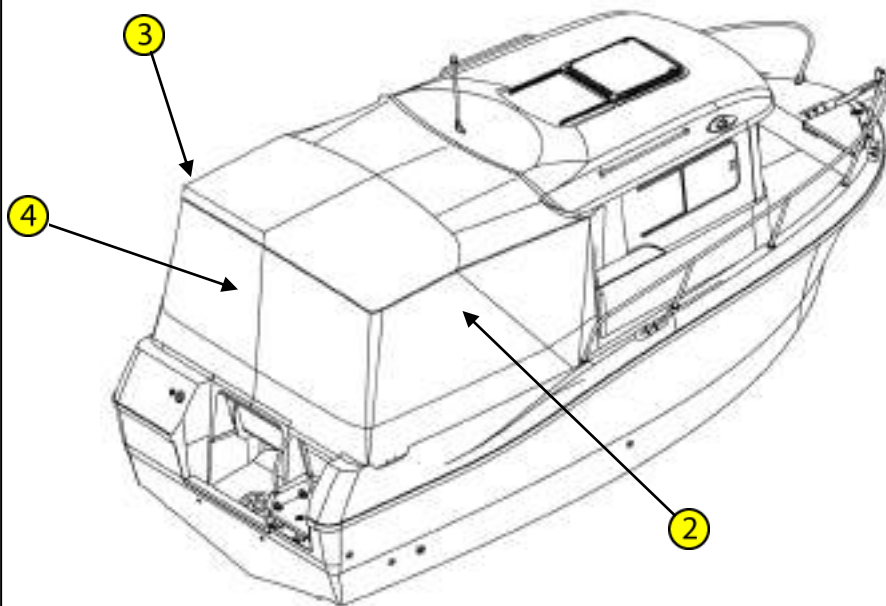

Full Enclosure

Quicksilver 605PH— Electrical Systems

1. DC Electrical System

The DC electrical system is powered by a single battery, and is kept charged by the engine driven alternator.

2. Battery

Refer to your engine owner's manual for exact battery requirements.

To remove the battery cables:

1. Turn off all items drawing power from the battery.
2. Turn the battery switch to the OFF position.
3. Remove the negative cable first, then the positive cable.

To replace the cables, install the positive cable first, then the negative cable.

3. Battery Box

The battery box, located in the aft bilge, houses the battery. This box can be accessed via the starboard aft cockpit floor hatch. The battery can be installed or removed by loosening the strap and removing the lid on the battery box. It should always be installed and secured within the battery box installed on your boat. This will ensure that the battery will not move around while the boat is underway.

⚠ CAUTION

Never use an open flame in the battery storage area. Avoid striking sparks in the battery area.

⚠ CAUTION

Always disconnect the battery before doing any work on the electrical system. Never turn off the battery switches or disconnect the battery cables while the engines are running.

4. Battery Switch

Your vessel is equipped with a battery switch to control the delivery of DC power from the battery. The battery switch is located on the starboard side under the starboard aft coaming cap. When you turn the battery switch to the ON position, power is provided from the battery to the entire boat. To turn on power, rotate the switch clockwise 90 degrees to the ON position.

NOTE: Never operate or turn off the battery switch when the engine is running as it may cause

NOTICE

The bilge pump still draws power from the battery, even if the switch is set to OFF. This is especially important for the bilge pump, so that it can operate anytime excess fluid accumulates in the bilge, which can occur when the boat is docked and unattended.

⚠ WARNING

Never work on the electrical system while the system is energized. Never leave the craft unattended with the electrical system energized.

Battery Switch Operation



OFF Position



ON Position

Quicksilver 605PH — Electrical Systems

damage to electronic components on the boat. Always operate the switch with the engine and accessories off.

5. Fuses and Breakers

Your boat will either have fuses or breakers protecting the DC electrical system. If you have to replace a fuse or electrical breaker, replace only with a fuse or breaker of the same rating. The amperage will be marked on the fuse or breaker, and it is recommended that you carry spare fuses or breakers.

WARNING

Use only fuses and breakers having the same amperage rating as the original or as specified. Use of higher amperage fuses or breakers is a fire hazard.

If a fuse or breaker is replaced with one that has a lower amperage, it may not be sufficient to carry the electrical load of the equipment it is connected to and will cause nuisance failures. If a fuse or breaker is replaced with one that has a higher amperage, it will not provide protection against an electrical malfunction and could create a possible fire hazard.

Fuses and breakers

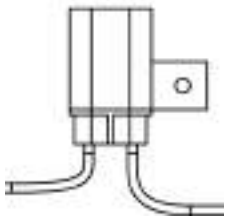

ATO/ATC fuse



Thermal breaker



ANL fuse



Magnetic breaker

Located at the helm, there is a fuse panel accessible via the under dash closeout. To access, simply remove the vinyl cover under the helm.

Located next to the battery in the starboard aft cockpit floor hatch, there are additional fuse holders. Their use and size are specified on a label under the hatch that covers the battery.

Auxiliary Fuses

- ① Battery switch
- ② Auxiliary fuses
- ③ Battery box

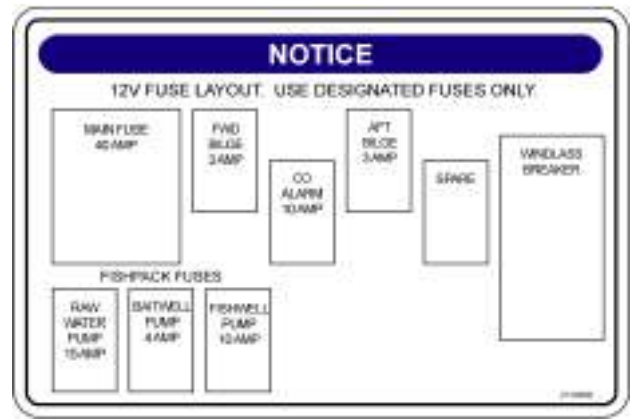
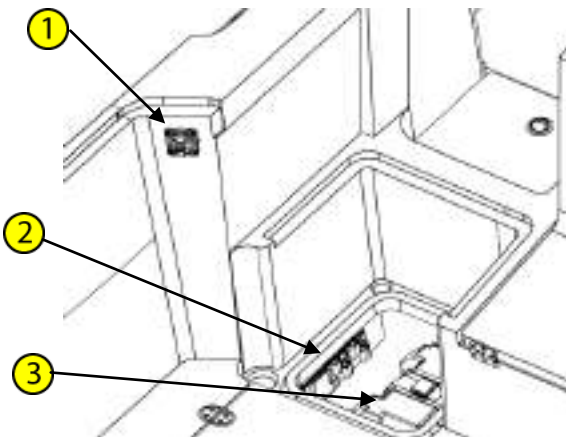

Quicksilver 605PH— Electrical Systems

Helm fuse panel

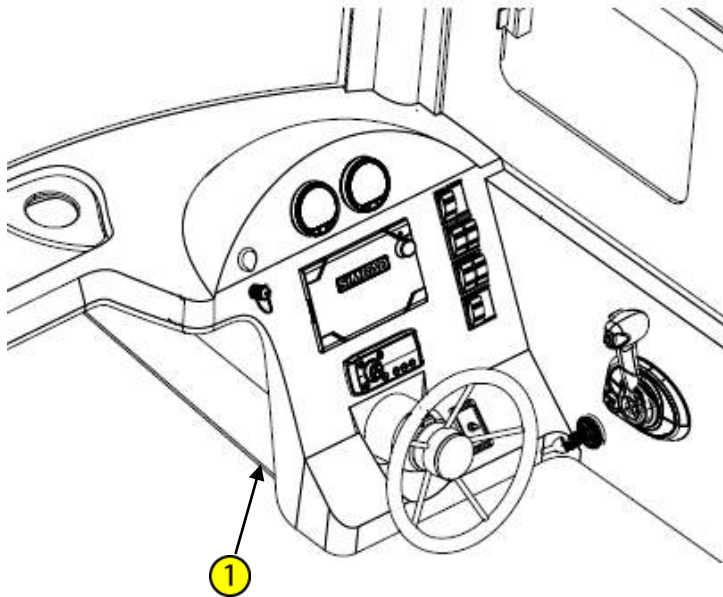

- ① Dash closeout panel
- ② Helm fuse panel
- ③ Electronics — 5 Amp
- ④ Starboard Wiper — 10 Amp
- ⑤ Navigation lights — 3 Amp
- ⑥ Forward bilge — 3 Amp
- ⑦ Aft bilge — 3 Amp
- ⑧ 12V outlet — 10 Amp
- ⑨ Stereo — 10 Amp
- ⑩ Refrigerator — 10 Amp
- ⑪ Horn — 5 Amp
- ⑫ Spare — 10 Amp
- ⑬ Spare — 5 Amp
- ⑭ Lighting — 5 Amp
- ⑮ Blank

Helm fuse panel 1

Helm fuse panel 2

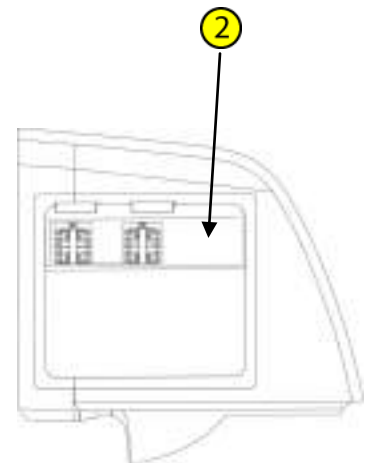
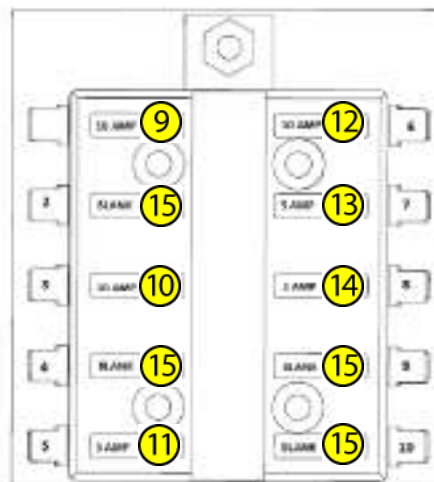
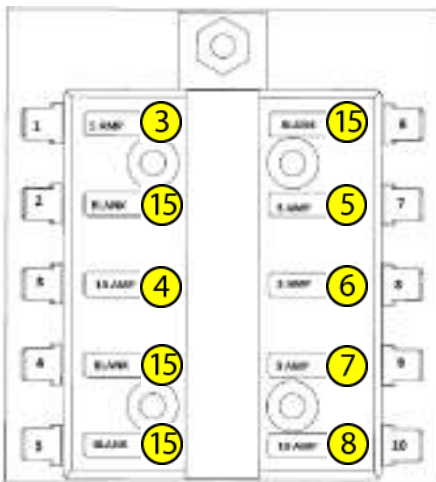

6. Electrical Schematics

This owner's manual contains electrical schematics and wiring harness illustrations for your boat. These electrical schematics were generated by the Electrical Engineering Department for technical reference and service technicians. Quicksilver® does not recommend that you attempt to work on the boat's electrical system yourself. Instead, we recommend that you take your boat to your local authorized Quicksilver® dealer for service. Quicksilver® reserves the right to change or update the electrical system on any model at any time without notice to the consumer and is not obligated to make any updates to units built prior to the change.

Quicksilver 605PH — Electrical Systems

DC Wiring Schematic

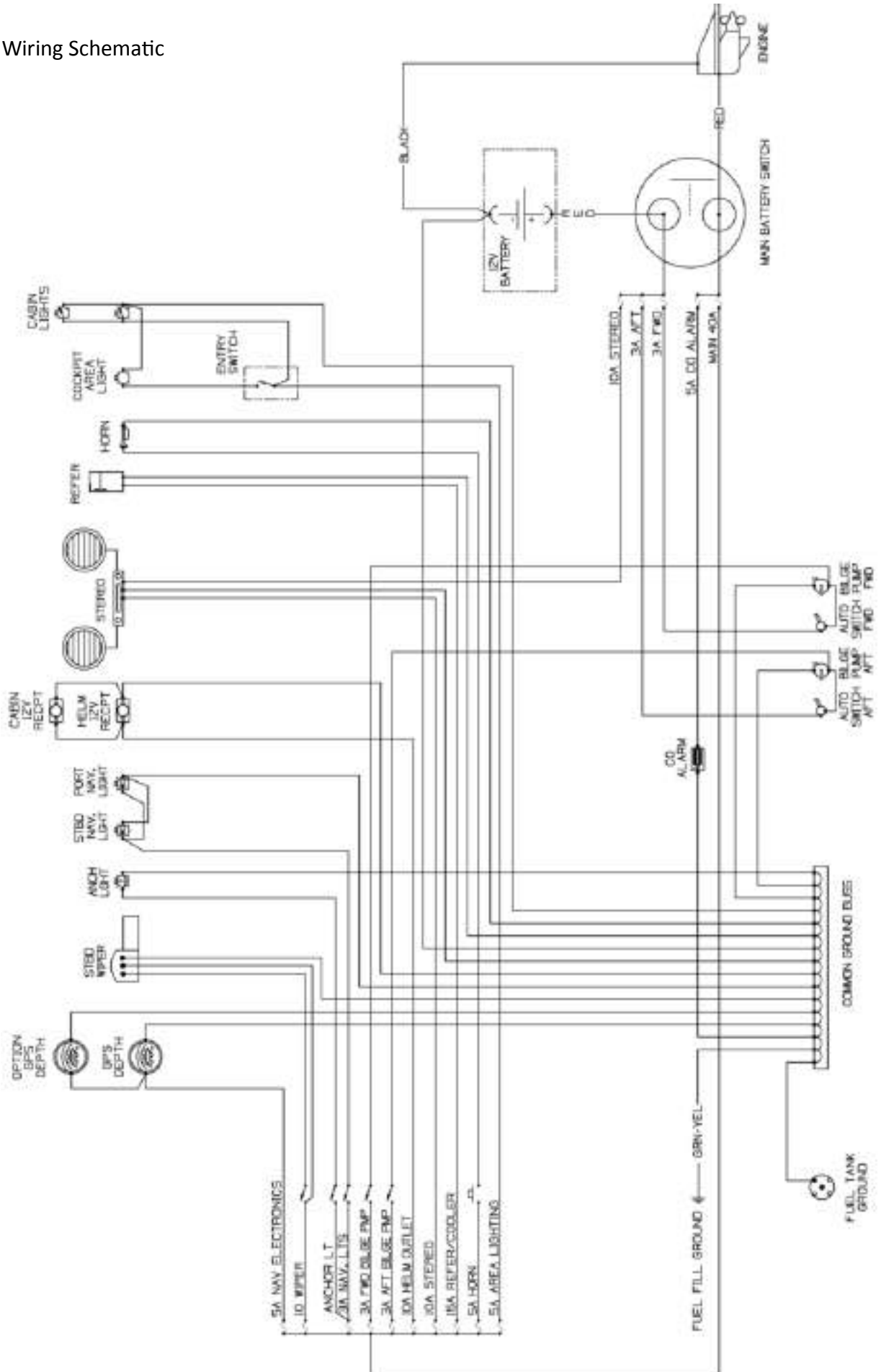

Quicksilver 605PH— Electrical Systems

Fish Pack Schematic

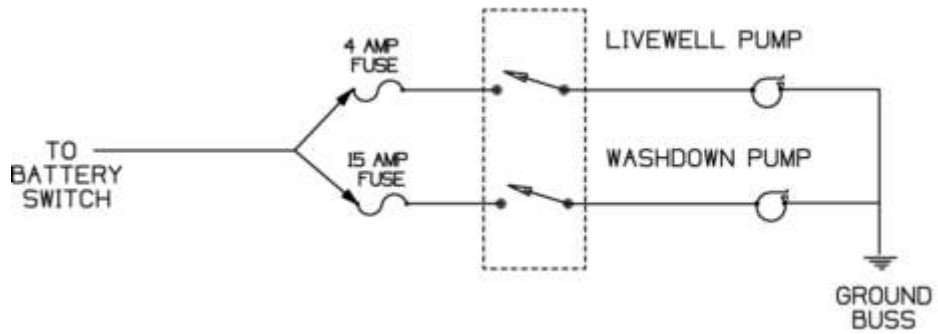

Bow Windlass Schematic

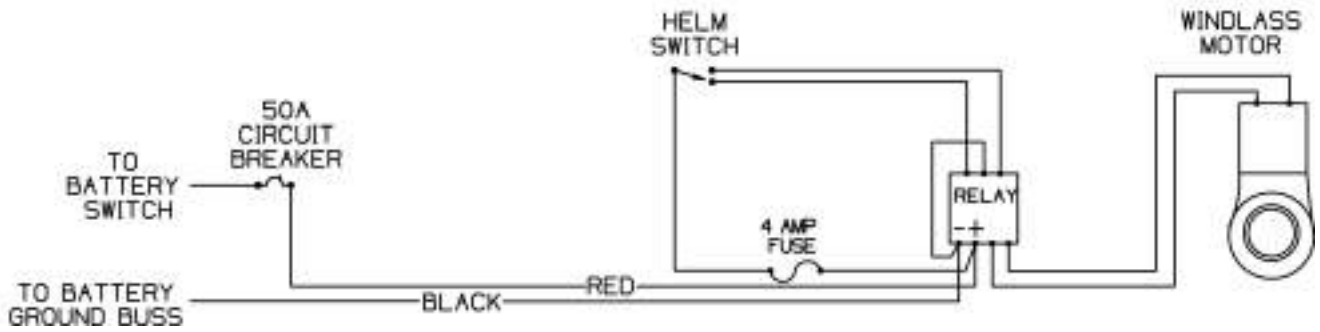

Quicksilver 605PH — Maintenance

1. Maintenance

Routine inspection, service and maintenance of your boat, systems and components are vital to assure your safety, and will prolong the life of your boat.

The interval between necessary service or maintenance is highly variable, depending on the environment in which your boat will be used. For example, corrosion of boat parts and components will occur far more rapidly in a salt water environment than on a boat which is used in fresh water.

This section provides only general guidelines for the care and cleaning of your boat. It is your responsibility to determine whether maintenance and care intervals need to be accelerated due to your boat usage and/or operating environment. If you have any question regarding maintenance of your boat, contact your local Quicksilver® dealer for additional assistance.

DANGER

When using chemicals, read all information from the manufacturer regarding safety and handling of the material. Wear proper protective equipment to ensure personal safety. Work only in well ventilated areas and keep all chemicals away from open flames.

NOTICE

Refer to the individual manufacturer's manuals, which can be found in the Owner's Manual packet, for care and maintenance of equipment and components. In some cases, failure to do so could void the warranty.

2. Hull & Deck Surfaces

Fresh water, saltwater and water temperature can all affect the types of growth that you will find on your boat's hull. Any growth will affect the boat's performance and overall look. If it has been a while between inspections you might notice algae or slime growth on the hull. This can be cleaned with a coarse towel or soft bristle brush. The growth should be cleaned immediately after the boat has been removed from the water. If the growth is allowed to dry it will be much harder to remove.

Compounding may be necessary to remove more stubborn stains and chalking from the surface of your boat. If compounding is necessary it must be done after a thorough washing and prior to waxing. If the growth is more severe, you may need to enlist the services of a professional hull cleaning company. Check with your Quicksilver® dealer for recommendations on a compatible rubbing compound for your boat or a professional hull cleaning company in your area.

Waxing Gel Coat Surfaces

Waxing is necessary to provide added protection to the gel coat. A good cleaning and waxing will also ensure that your boat will be protected and look good longer. Make sure the surface of your boat has received a thorough washing and rinsing and is clean before waxing. Next, verify that any minor scratches or surface pitting is cleaned of compound residue. Use a good quality carnauba wax or a high quality wax designed for marine gel coat. Apply several coats.

NOTICE

Waxing of the exterior surfaces is recommended to be done at least twice a year to protect the gel coat of your boat.

Gel Coat Surface Maintenance

If using a pressure washer to clean the hull and deck surfaces of your boat it is important that you use the wide fan nozzle only and move the spray head in a continuous motion. Do not concentrate the high pressure on a small area of the boat surface and never use the fine pinpoint nozzle as the concentrated stream can cause damage to the surface of your boat. Do not pressure wash the helm as the water stream may damage the electronics and gauges as well as other sensitive equipment.

Quicksilver 605PH — Maintenance

When staining from build-up does occur, use only cleaning agents that are recommended for marine gel coat. Never use an abrasive cleaner to wash your boat's hull, nor use an abrasive pad to attempt to remove stubborn stains. Never use strong solvents to clean.

3. Component Maintenance

Stainless Steel

Stainless steel is strong and corrosion resistant, but still requires maintenance to keep its appearance. Frequent routine cleaning of your stainless steel will help maintain the finish.

Quicksilver® recommends that you wash stainless steel components with mild soap and cold or lukewarm water after every use of the boat. If added protection is necessary, apply a cleaning wax.

Even the finest cleaning powders can scratch or burnish a mill-rolled surface. On polished finishes, rubbing or wiping should be done in the direction of the polish lines, not across them.

Crevice corrosion, a brownish coloring which occurs where two pieces of stainless hardware meet is caused by impurities in water and air. It can be easily cleaned with a good grade marine polish using a sponge, cloth or small bristled brush (for tight and confined spaces).

NOTICE

The cleaner your stainless steel can be kept, the greater the assurance of optimum corrosion resistance. Without proper care even the best stainless steel will corrode.

NOTICE

Never use abrasive cleaners, detergents or soft scrub type cleaners to clean stainless steel. Never use abrasive pads, brushes or sponges to attempt to remove stubborn stains. Never use strong solvents or detergents which contain chlorine, and never use silver cleaners.

Cushions

Saltwater, salt residue, dirt, ultra-violet rays etc. will take their toll on vinyl products causing them to lose their luster and texture. To clean, remove ordinary dirt and smudges with a mild soap and water solution. Dry with a soft, lint-free cloth or towel. More difficult stains can be cleaned using rubbing alcohol (isopropyl alcohol). Rinse cleaned area with fresh water and dry with a clean, soft, lint-free cloth or towel.

Your cushions are not waterproof. They are constructed of open-cell foam and will absorb and hold water. Do not leave the cushions in standing water or exposed to heavy, prolonged rain. If, in the event your cushions become waterlogged, remove the foam from the cushion, press as much water as you can from the foam and allow to air dry. To prevent mildew, keep the vinyl dry and make sure that moisture does not accumulate between the cushions.

CAUTION

Solvents are flammable. Exercise proper care. Wear rubber gloves during all cleaning activity. Use caution when cleaning around stitching or decorative trim as these solvents could seriously damage such areas.

Canvas

Chafing, fiber wear from dirt and grit and deterioration from ultraviolet light can cause your canvas to degrade over time. The fabric should be cleaned regularly before substances such as dirt, pollen, etc. are allowed to accumulate on and become embedded in the fabric. The canvas can be cleaned without being removed from the installation.

Quicksilver 605PH — Maintenance

After each use, especially if used in salt water areas, rinse the canvas completely with fresh cold water.

On a regular basis, brush off any loose dirt, pollen, etc., and hose down with water and clean with a mild solution of a natural soap in lukewarm water (maximum 38°C). Allow the canvas to soak, however, do not let the soap dry. Rinse thoroughly with fresh water. Let the canvas dry completely. Do not store any of the canvas pieces while wet.

The effects of ultraviolet light can sometimes be reduced by chemical treatment of canvas items. Consult your Quicksilver® dealer or check your canvas manufacturer's manual before using any chemical treatments on your canvas.

To clean stubborn stains, soak fabric for approximately twenty minutes in a mild solution consisting of no more than 30 ml of bleach and 15 ml of natural soap per liter of lukewarm water (not to exceed 38° C). Rinse thoroughly in cold water several times, then allow the fabric to air dry completely. Retreat the fabric using an air curing product such to ensure water and stain repellency. Refer to the canvas vendor's recommendation for additional information.

Zippers & Hardware

Lubricate zippers and fasteners periodically with a clear silicone spray. In the absence of silicone spray, a wax candle can be used to lubricate the zipper track. Replace any missing fasteners or any fasteners showing signs of corrosion.

NOTICE

DO NOT use petroleum based products, such as petroleum jelly, on the zippers or fasteners.

Vinyl Windows

The canvas on your boat may incorporate Eisenglass polycarbonate windows. Regular cleaning, utilizing compatible cleaners, coupled with proper maintenance techniques will significantly improve the vinyl's service life.

NOTICE

Never use regular window cleaners, detergents, abrasives, petroleum based products, or alcohol to clean your vinyl windows. Do not handle vinyl with sunscreen on your hands. Sunscreen will permanently cloud the vinyl where handled. Do not fold vinyl panels. Store flat or rolled with smooth paper or soft cloth between layers when dry.

Rinse vinyl thoroughly with clean water to remove any dust, dirt particles, salt water or environmental agents before applying cleaning products. This should be done frequently to avoid build up of salt water, dirt and other environmental contaminants. Using a soft non-abrasive cloth, wash windows inside and out with a mild soap and water solution. Rinse completely with cool water. DO NOT USE DETERGENTS.

Use separate clean, soft cloths or sponges for application of cleaners and polishes (Use the manufacturer's recommended products). Only use a small amount of cleaner or streaking may occur. If you get streaking or a leftover film, rinse the window with clean water.

Quicksilver 605PH — Maintenance

Dry the window with a soft cloth or chamois to prevent water spots. Polish with a separate cloth. Don't leave cleaners on for long periods; immediately wash the window. Finally, don't apply cleaners in direct sunlight or at elevated temperatures.

To minimize fine or hairline scratches apply a mild automotive polish and remove with a soft, clean cloth. Do not use abrasive plastic polishes.

Tempered Glass Windshield

Use commercially available glass cleaners or a mixture of fresh water and vinegar to clean your glass windows, windshield or portlights. Dry with a soft terry cloth towel or chamois.

NOTICE

DO NOT use abrasives, harsh chemicals, or metal scrapers on glass.

Acrylic Windscreens & Windows

The use of a polycarbonate protective cleaner/restorer is recommended to keep your acrylic scratch resistant, clean and minimize the deteriorating effects of sunlight.

To clean, rinse the windscreen/window thoroughly with clean water to remove any dust, dirt particles, salt water or environmental agents before applying cleaning products. Use your bare hand, with plenty of water, to feel and dislodge any stuck-on dirt or foreign particles. This should be done frequently to avoid build up of salt water, dirt and other environmental contaminants.

Using a soft non-abrasive cloth, wash windows inside and out with a mild soap and water solution. Rinse completely with cool water. Do not use detergents. Blot dry with a soft cloth or chamois to prevent water spots.

NOTICE

Never use a dry cloth or duster or glass cleaning solutions on acrylic. DO NOT use solvents such as acetone, silicone spray, benzene, carbon tetrachloride, fire extinguisher fluid, dry cleaning fluid, lacquer thinner, glass cleaning solution or harsh detergents on acrylic. These substances will attack the surface of the acrylic.