

Troubleshooting

M190C, M216C, M250C and M300C Marine Engine

PJ (Engine)



Important Safety Information

Most accidents that involve product operation, maintenance and repair are caused by failure to observe basic safety rules or precautions. An accident can often be avoided by recognizing potentially hazardous situations before an accident occurs. A person must be alert to potential hazards. This person should also have the necessary training, skills and tools to perform these functions properly.

Improper operation, lubrication, maintenance or repair of this product can be dangerous and could result in injury or death.

Do not operate or perform any lubrication, maintenance or repair on this product, until you have read and understood the operation, lubrication, maintenance and repair information.

Safety precautions and warnings are provided in this manual and on the product. If these hazard warnings are not heeded, bodily injury or death could occur to you or to other persons.

The hazards are identified by the "Safety Alert Symbol" and followed by a "Signal Word" such as "DANGER", "WARNING" or "CAUTION". The Safety Alert "WARNING" label is shown below.



The meaning of this safety alert symbol is as follows:

Attention! Become Alert! Your Safety is Involved.

The message that appears under the warning explains the hazard and can be either written or pictorially presented.

Operations that may cause product damage are identified by "NOTICE" labels on the product and in this publication.

Perkins cannot anticipate every possible circumstance that might involve a potential hazard. The warnings in this publication and on the product are, therefore, not all inclusive. If a tool, procedure, work method or operating technique that is not specifically recommended by Perkins is used, you must satisfy yourself that it is safe for you and for others. You should also ensure that the product will not be damaged or be made unsafe by the operation, lubrication, maintenance or repair procedures that you choose.

The information, specifications, and illustrations in this publication are on the basis of information that was available at the time that the publication was written. The specifications, torques, pressures, measurements, adjustments, illustrations, and other items can change at any time. These changes can affect the service that is given to the product. Obtain the complete and most current information before you start any job. Perkins dealers or Perkins distributors have the most current information available.



When replacement parts are required for this product Perkins recommends using Perkins replacement parts.

Failure to heed this warning can lead to premature failures, product damage, personal injury or death.

Table of Contents

Troubleshooting Section

Electronic Troubleshooting

System Overview	6
Glossary	8
Electronic Service Tools	12
Indicator Lamps	14
Replacing the ECM	17
Self-Diagnostics	18
Sensors and Electrical Connectors	19
Engine Wiring Information	23
ECM Harness Connector Terminals	28

Programming Parameters

Programming Parameters	30
Test ECM Mode	30
Factory Passwords	30
Flash Programming	31
Injector Trim File	31

Customer Specified Parameters

Customer Specified Parameters	33
Customer Specified Parameters Table	35
Customer Specified Parameters Worksheet	36

System Configuration Parameters

System Configuration Parameters	37
---------------------------------------	----

Troubleshooting without a Diagnostic Code

Alternator Noise	38
Alternator Will Not Charge	38
Battery	39
Can Not Reach Top Engine RPM	39
Coolant in Engine Oil	40
Coolant Temperature Is Too High	41
ECM Will Not Accept Factory Passwords	42
ECM Will Not Communicate with Other Systems or Display Modules	42
Electronic Service Tool Will Not Communicate with ECM	43
Engine Cranks but Will Not Start	44
Engine Has Early Wear	47
Engine Misfires, Runs Rough or Is Unstable	48
Engine Oil in Cooling System	49
Engine Speed Does Not Change	50
Engine Stalls at Low RPM	50
Engine Vibration	51
Engine Will Not Crank	52
Excessive Black Smoke	53
Excessive Engine Oil Consumption	54
Excessive Fuel Consumption	55
Excessive Valve Lash	57
Excessive White Smoke	58
Exhaust Temperature Is High	59
Fuel Dilution of Engine Oil	59
Intermittent Engine Shutdown	59
Intermittent Low Power or Power Cutout	60
Low Engine Oil Pressure	62
Low Power/Poor or No Response to Throttle	63

Mechanical Noise (Knock) in Engine	65
Noise Coming from Cylinder	65
Poor Acceleration or Response	66
Transmission Oil Pressure Is High	67
Transmission Oil Temperature Is High	68

Troubleshooting with a Diagnostic Code

Flash Codes	69
Diagnostic Codes	69
Diagnostic Code Cross Reference	71
No Diagnostic Codes Detected	73
CID 0001 FMI 02	74
CID 0001 FMI 05	74
CID 0001 FMI 06	75
CID 0001 FMI 07	75
CID 0002 FMI 02	75
CID 0002 FMI 05	76
CID 0002 FMI 06	76
CID 0002 FMI 07	77
CID 0003 FMI 02	77
CID 0003 FMI 05	77
CID 0003 FMI 06	78
CID 0003 FMI 07	78
CID 0004 FMI 02	79
CID 0004 FMI 05	79
CID 0004 FMI 06	80
CID 0004 FMI 07	80
CID 0005 FMI 02	80
CID 0005 FMI 05	81
CID 0005 FMI 06	81
CID 0005 FMI 07	82
CID 0006 FMI 02	82
CID 0006 FMI 05	83
CID 0006 FMI 06	83
CID 0006 FMI 07	84
CID 0041 FMI 03	84
CID 0041 FMI 04	84
CID 0091 FMI 08	85
CID 0091 FMI 13	85
CID 0094 FMI 03	85
CID 0094 FMI 04	85
CID 0096 FMI 03	86
CID 0096 FMI 04	86
CID 0100 FMI 03	86
CID 0100 FMI 04	87
CID 0100 FMI 10	87
CID 0110 FMI 03	87
CID 0110 FMI 04	88
CID 0127 FMI 03	88
CID 0127 FMI 04	88
CID 0168 FMI 00	89
CID 0168 FMI 01	89
CID 0168 FMI 02	89
CID 0172 FMI 03	90
CID 0172 FMI 04	90
CID 0174 FMI 03	91
CID 0174 FMI 04	91
CID 0177 FMI 03	91
CID 0177 FMI 04	91
CID 0190 FMI 08	92
CID 0253 FMI 02	92
CID 0261 FMI 11	92
CID 0262 FMI 03	93

CID 0262 FMI 04	93	Indicator Lamp Circuit - Test	183
CID 0268 FMI 02	93	Injector Data Incorrect - Test	186
CID 0342 FMI 08	94	Injector Solenoid Circuit - Test	188
CID 0342 FMI 11	94	Speed Control (PWM) - Test	196
CID 0526 FMI 05	94	Starting Aid (Glow Plug) Relay Circuit - Test	201
CID 0526 FMI 06	95	Switch Circuits - Test	205
CID 0526 FMI 07	95	Throttle Position Sensor - Test	207
CID 0535 FMI 03	96	Transmission Oil Temperature - Test	209
CID 0535 FMI 04	96	Wastegate Solenoid - Test	212
CID 0774 FMI 08	96		
CID 0774 FMI 13	97	Index Section	
CID 1779 FMI 05	97	Index	218
CID 1779 FMI 06	97		
CID 1785 FMI 03	98		
CID 1785 FMI 04	98		
CID 1785 FMI 10	98		
CID 1797 FMI 03	99		
CID 1797 FMI 04	99		
CID 1834 FMI 02	100		
CID 2246 FMI 05	100		
CID 2246 FMI 06	100		

Troubleshooting with an Event Code

Event Codes	102
E096 High Fuel Pressure	104
E113 High Transmission Oil Pressure	104
E119 Low Fuel Level	105
E179 Alternator Not Charging	105
E194 High Exhaust Temperature	105
E198 Low Fuel Pressure	106
E232 High Fuel/Water Separator Water Level	106
E268 Unexpected Engine Shutdown	107
E360 Low Engine Oil Pressure	107
E361 High Engine Coolant Temperature	108
E362 Engine Overspeed	109
E363 High Fuel Supply Temperature	109
E396 High Fuel Rail Pressure	110
E398 Low Fuel Rail Pressure	110
E539 High Intake Manifold Air Temperature	111
E877 High Transmission Oil Temperature	112
E1044 High Intake Manifold Pressure	112
E1045 Low Intake Manifold Pressure	112
E2143 Low Engine Coolant Level	113

Diagnostic Functional Tests

5 Volt Sensor Supply Circuit - Test	115
CAN Data Link Circuit - Test	122
Coolant Level Sensor Circuit - Test	126
Data Link Circuit - Test	131
ECM Memory - Test	137
Electrical Connectors - Inspect	138
Electrical Power Supply Circuit - Test	142
Engine Pressure Sensor Open or Short Circuit - Test	146
Engine Speed/Timing Sensor Circuit - Test	154
Engine Temperature Sensor Open or Short Circuit - Test	159
Engine Temperature Sensor Open or Short Circuit - Test	165
Fuel Level - Test	170
Fuel Rail Pump Solenoid - Test	173
Ignition Keyswitch Circuit and Battery Supply Circuit - Test	177

Troubleshooting Section

Electronic Troubleshooting

i04009195

System Overview

- | | | |
|---|------------------------------------|--|
| (1) Electronic unit injectors | (18) Secondary throttle | (35) Fuel supply pressure sensor (if equipped) |
| (2) Electronic Control Module (ECM) | (19) Warning lamp | (36) Transmission oil pressure sensor (if equipped) |
| (3) Electronic Service Tool (EST) | (20) Diagnostic lamp | (37) Transmission oil temperature sensor (if equipped) |
| (4) Diagnostic connector | (21) Maintenance lamp | (38) Fuel level sensor (if equipped) |
| (5) SMMS relay | (22) Low coolant level lamp | (39) Fuel temperature sensor (if equipped) |
| (6) Starting motor | (23) Low oil pressure lamp | (40) Fuel rail pressure sensor |
| (7) CAN bus terminator | (24) High coolant temperature lamp | (41) Intake manifold air pressure sensor |
| (8) Positive glow plug relay | (25) Water in fuel lamp | (42) Intake manifold air temperature sensor |
| (9) Glow plugs | (26) Ignition switch | (43) Coolant temperature sensor |
| (10) Negative glow plug relay | (27) Remote shutdown switch | (44) Oil pressure sensor |
| (11) Alternator charging relay input | (28) Troll mode switch | (45) Primary speed/timing sensor |
| (12) Coolant level sensor (if equipped) | (29) Slow vessel mode switch | (46) Secondary speed/timing sensor |
| (13) Exhaust gas temperature sensor (if equipped) | (30) Throttle synchronize 1 switch | (47) Wastegate regulator (if equipped) |
| (14) Customer interface connector | (31) Throttle synchronize 2 switch | (48) Solenoid for the fuel rail pump |
| (15) Electronic display | (32) Maintenance clear switch | |
| (16) 12V or 24V power supply | (33) Trip clear switch | |
| (17) Primary throttle | (34) Water in fuel sensor | |

The engine is designed for electronic control. The engine has an Electronic Control Module (ECM), a fuel rail pump and electronic unit injectors. All of these items are electronically controlled. There are also a number of engine sensors. Turbocharged engines can be equipped with an electronically controlled wastegate for the turbocharger. The ECM controls the engine operating parameters through the software within the ECM and the inputs from the various sensors. The software contains parameters that control the engine operation. The parameters include all of the operating maps and customer-selected parameters.

The electronic system consists of the ECM, the engine sensors, and inputs from the application. The ECM is the computer. The flash file is the software for the computer. The flash file defines the following characteristics of the engine:

- Engine power
- Torque curves
- Engine speed (rpm)
- Engine Noise
- Smoke and Emissions

The ECM determines the injection timing, the amount of fuel that is delivered to the cylinders and the intake manifold pressure if an electronically controlled wastegate is installed on the turbocharger. These decisions are based on the actual conditions and the desired conditions at any given time.

Engine Speed Governor

The governor has software that compares the desired engine speed to the actual engine speed. The actual engine speed is determined through the primary speed/timing sensor and the secondary speed/timing sensor. If the desired engine speed is greater than the actual engine speed, the governor injects more fuel in order to increase engine speed. If the actual engine speed is greater than the desired engine speed, the governor limits the amount of fuel that is supplied to the electronic unit injectors in order to reduce engine speed.

Timing Considerations

Fuel injection timing is determined by the ECM after considering input from the following components:

- Engine coolant temperature sensor
- The sensor for the intake manifold air temperature
- The sensor for the intake manifold pressure
- Speed/timing sensors
- Throttle position sensor

At engine start-up, the ECM determines the top center position of the number 1 cylinder from the speed/timing sensors. The ECM determines when fuel injection should occur relative to the top center position. The ECM optimizes engine performance by control of each of the electronic unit injectors so that the required amount of fuel is injected at the precise point of the engine's cycle. The electronic unit injectors are supplied with high-pressure fuel from the fuel rail. The ECM also provides the signal to the solenoid in the fuel rail pump. The solenoid in the fuel rail pump controls a valve in the fuel rail pump. This valve controls the pressure in the fuel rail. Fuel that is not required for the engine is diverted away from the fuel rail pump back to the fuel tank.

The ECM adjusts injection timing and fuel pressure for the best engine performance, the best fuel economy, and the best control of exhaust emissions.

Fuel Injection

The flash file inside the ECM sets certain limits on the amount of fuel that can be injected.

The Fuel Ratio Control Limit is a limit that is based on intake manifold pressure and engine rpm. The FRC Limit is used to control the air/fuel ratio in order to control the engine's exhaust emissions. When the ECM senses a higher intake manifold pressure, the ECM increases the FRC Limit. A higher intake manifold pressure indicates that there is more air in the cylinder. When the ECM increases the FRC Limit, the ECM allows more fuel into the cylinder.

The Rated Fuel Limit is a limit that is based on the power rating of the engine and on the engine rpm. The Rated Fuel Limit enables the engine power and torque outputs to conform to the power and torque curves of a specific engine model.

These limits are in the flash file and these limits cannot be changed by the operator.

Diagnostic Codes

When the ECM detects an electronic system fault, the ECM generates a diagnostic code. Also, the ECM logs the diagnostic code in order to indicate the time of the occurrence of the fault. The ECM also logs the number of occurrences of the fault. Diagnostic codes are provided in order to indicate that the ECM has detected an electrical fault or an electronic fault with the engine control system. In some cases, the engine performance can be affected when the condition that is causing the code exists.

If the operator indicates that a performance problem occurs, the diagnostic code may indicate the cause of the fault. Use the electronic service tool to access the diagnostic codes. The fault should then be corrected.

Event Codes

Event Codes are used to indicate that the ECM has detected an abnormal engine operating condition. The ECM will log the occurrence of the event code. This does not indicate an electrical malfunction or an electronic malfunction. For example, if the temperature of the coolant in the engine is higher than the permitted limit, then the ECM will detect the condition. The ECM will then log an event code for the condition.

Programmable Parameters

Certain parameters that affect the engine operation may be changed with electronic service tools. The parameters are stored in the ECM and some of the parameters are protected from unauthorized changes by passwords. These parameters are System Configuration Parameters.

System Configuration Parameters are set at the factory. System Configuration Parameters affect the emissions or the power ratings within the engine. Factory passwords must be obtained and used in order to change some of the System Configuration Parameters. Examples of these parameters are FLS and FTS.

Passwords

System Configuration Parameters are protected by factory passwords. Factory passwords are calculated on a computer system that is available only to Perkins distributors. Since factory passwords contain alphabetic characters, only an electronic service tool may change System Configuration Parameters. System Configuration Parameters affect the power rating or the emissions.

Refer to Troubleshooting, "Programming Parameters" and Troubleshooting, "Factory Passwords".

i04012391

Glossary

Active Diagnostic Code – An active diagnostic code alerts the operator or the service technician that an electronic system malfunction is currently present. Refer to the term "Diagnostic Code" in this glossary.

Adaptive Trim – This is a software process that is performed in the Electronic Control Module (ECM) that optimizes engine performance.

Before Top Center (BTC) – BTC is the 180 degrees of crankshaft rotation before the piston reaches the top dead center position in the normal direction of rotation.

Breakout Harness – A breakout harness is a test harness that is designed to connect into the engine harness. This connection allows a normal circuit operation and the connection simultaneously provides a Breakout T in order to measure the signals.

Bypass Circuit – A bypass circuit is a circuit that is used as a substitute circuit for an existing circuit. A bypass circuit is typically used as a test circuit.

CAN Data Link (see also J1939 CAN Data Link) –

The CAN Data Link is a serial communications port that is used for communication with other microprocessor-based devices.

Code – Refer to “Diagnostic Code” or “Event Code”.

Communication Adapter Tool – The communication adapter provides a communication link between the ECM and the electronic service tool.

Component Identifier (CID) – The CID is a number that identifies the specific component of the electronic control system that has experienced a diagnostic code.

Coolant Temperature Sensor – The coolant temperature sensor detects the engine coolant temperature for all normal operating conditions and for engine monitoring.

Data Link – The Data Link is a serial communication port that is used for communication with other devices such as the electronic service tool.

Derate – Certain engine conditions will generate event codes. Also, engine derates may be applied. The map for the engine derate is programmed into the ECM software. The engine derate can be one or more of three types: reduction of rated power, reduction of rated engine speed, and reduction of rated machine speed for OEM products.

Desired Engine Speed – The desired engine speed is input to the electronic governor within the ECM. The electronic governor uses the signal from the throttle position sensor, the engine speed/timing sensor, and other sensors in order to determine the desired engine speed.

Diagnostic Code – A diagnostic code is sometimes referred to as a fault code. These codes indicate an electronic system malfunction.

Diagnostic Lamp – A diagnostic lamp is sometimes called the check engine light. The diagnostic lamp is used to warn the operator of the presence of an active diagnostic code. The lamp may not be included in all applications.

Digital Sensor Return – The common line (ground) from the ECM is used as ground for the digital sensors.

Digital Sensors – Digital sensors produce a pulse width modulated signal. Digital sensors are supplied with power from the ECM.

Digital Sensor Supply – The power supply for the digital sensors is provided by the ECM.

Direct Current (DC) – Direct current is the type of current that flows consistently in only one direction.

DT, DT Connector, or Deutsch DT – This is a type of connector that is used on Perkins engines. The connectors are manufactured by Deutsch.

Duty Cycle – Refer to “Pulse Width Modulation”.

Electronic Engine Control – The electronic engine control is a complete electronic system. The electronic engine control monitors the engine operation under all conditions. The electronic engine control also controls the engine operation under all conditions.

Electronic Control Module (ECM) – The ECM is the control computer of the engine. The ECM provides power to the electronics. The ECM monitors data that is input from the sensors of the engine. The ECM acts as a governor in order to control the speed and the power of the engine.

Electronic Service Tool – The electronic service tool allows a computer (PC) to communicate with the ECM.

Engine Monitoring – Engine Monitoring is the part of the electronic engine control that monitors the sensors. This also warns the operator of detected problems.

Engine Oil Pressure Sensor – The engine oil pressure sensor measures engine oil pressure. The sensor sends a signal to the ECM that is dependent on the engine oil pressure.

Engine Speed/Timing Sensor – An engine speed/timing sensor is a hall effect switch that provides a digital signal to the ECM. The ECM interprets this signal as the crankshaft position and the engine speed. Two sensors are used to provide the speed and timing signals to the ECM. The primary sensor is associated with the crankshaft and the secondary sensor is associated with the camshaft.

Event Code – An event code may be activated in order to indicate an abnormal engine operating condition. These codes usually indicate a mechanical problem instead of an electrical system problem.

Failure Mode Identifier (FMI) – This identifier indicates the type of failure that is associated with the component. The FMI has been adopted from the SAE practice of J1587 diagnostics. The FMI follows the parameter identifier (PID) in the descriptions of the fault code. The descriptions of the FMIs are in the following list.

0 – The data is valid but the data is above the normal operational range.

1 – The data is valid but the data is below the normal operational range.

2 – The data is erratic, intermittent, or incorrect.

- 3 – The voltage is above normal or the voltage is shorted high.
- 4 – The voltage is below normal or the voltage is shorted low.
- 5 – The current is below normal or the circuit is open.
- 6 – The current is above normal or the circuit is grounded.
- 7 – The mechanical system is not responding properly.
- 8 – There is an abnormal frequency, an abnormal pulse width, or an abnormal time period.
- 9 – There has been an abnormal update.
- 10 – There is an abnormal rate of change.
- 11 – The failure mode is not identifiable.
- 12 – The device or the component is damaged.

Flash File – This file is software that is inside the ECM. The file contains all the instructions (software) for the ECM and the file contains the performance maps for a specific engine. The file may be reprogrammed through flash programming.

Flash Programming – Flash programming is the method of programming or updating an ECM with an electronic service tool over the data link instead of replacing components.

Fuel Injector E-Trim – Fuel injector E-trim is a software process that allows precise control of fuel injectors by parameters that are programmed into the ECM for each fuel injector. With the use of the electronic service tool, the service technician can read status information for the E-Trim. Data for E-Trim can also be programmed.

FRC – See “Fuel Ratio Control”.

Fuel Pump – See “Fuel Rail Pump”.

Fuel Rail – This item is sometimes referred to as the High Pressure Fuel Rail. The fuel rail supplies fuel to the electronic unit injectors. The fuel rail pump and the fuel rail pressure sensor work with the ECM in order to maintain the desired fuel pressure in the fuel rail. This pressure is determined by calibration of the engine in order to enable the engine to meet emissions and performance requirements.

Fuel Rail Pressure Sensor – The fuel rail pressure sensor sends an electronic signal to the ECM that is dependent on the pressure of the fuel in the fuel rail.

Fuel Rail Pump – This item is sometimes referred to as the High Pressure Fuel Rail Pump. This is a device that supplies fuel under pressure to the fuel rail (high-pressure fuel rail).

Fuel Rail Pump Solenoid Valve – This is sometimes referred to as the High Pressure Fuel Rail Pump Solenoid Valve. This is a control device in the high-pressure fuel rail pump. The ECM controls the pressure in the fuel rail by using this valve to divert excess fuel from the pump to the fuel tank.

Fuel Ratio Control (FRC) – The FRC is a limit that is based on the control of the ratio of the fuel to air. The FRC is used for purposes of emission control. When the ECM senses a higher intake manifold air pressure (more air into the cylinder), the FRC increases the FRC Limit (more fuel into the cylinder).

Full Load Setting (FLS) – The FLS is the parameter that represents the fuel system adjustment. This adjustment is made at the factory in order to fine-tune the fuel system. The correct value for this parameter is stamped on the engine information ratings plate. This parameter must be programmed.

Full Torque Setting (FTS) – The FTS is the parameter that represents the adjustment for the engine torque. This adjustment is made at the factory in order to fine-tune the fuel system. This adjustment is made with the FLS. This parameter must be programmed.

Glow Plug – The glow plug is a starting aid for cold conditions. One glow plug is installed in each combustion chamber in order to improve the ability of the engine to start. The ECM uses information from the engine sensors such as the engine temperature to determine when the glow plug relay must provide power to each glow plug. Each of the glow plugs then provides a very hot surface in the combustion chamber in order to vaporize the mixture of air and fuel. This improves ignition during the compression stroke of the cylinder.

Glow Plug Relay – The glow plug relay is controlled by the ECM in order to provide high current to the glow plugs that are used in the starting aid system.

Harness – The harness is the bundle of wiring (loom) that connects all components of the electronic system.

Hertz (Hz) – Hertz is the measure of electrical frequency in cycles per second.

High Pressure Fuel Rail Pump – See “Fuel Rail Pump”.

High Pressure Fuel Rail Pump Solenoid Valve – See “Fuel Rail Pump Solenoid Valve”.

High Pressure Fuel Rail – See “Fuel Rail”.

Injector Codes – The injector codes or trim codes are numeric codes or alphanumeric codes that are etched or stamped on individual electronic unit injectors. These codes are used to fine-tune the fuel delivery.

Injector Trim Files – Injector trim files are downloaded from a disk to the ECM. The injector trim files compensate for variances in manufacturing of the electronic unit injector and for the life of the electronic unit injector. The serial number for the electronic unit injector must be obtained in order to retrieve the correct injector trim file.

Intake Manifold Air Temperature Sensor – The intake manifold air temperature sensor detects the air temperature in the intake manifold. The ECM monitors the air temperature and other data in the intake manifold in order to adjust injection timing and other performance functions.

Intake Manifold Pressure Sensor – The Intake Manifold Pressure Sensor measures the pressure in the intake manifold. The pressure in the intake manifold may be different to the pressure outside the engine (atmospheric pressure). The difference in pressure may be caused by an increase in air pressure by a turbocharger (if equipped).

Integrated Electronic Controls – The engine is designed with the electronic controls as a necessary part of the system. The engine will not operate without the electronic controls.

J1939 CAN Data Link – This data link is a SAE standard diagnostic communications data link that is used to communicate between the ECM and the electronic devices.

Logged Diagnostic Codes – Logged diagnostic codes are codes which are stored in the memory. These codes are meant to be an indicator of possible causes for intermittent problems. Refer to the term “Diagnostic Code” in this glossary for more information.

OEM – OEM is an abbreviation for the Original Equipment Manufacturer. This is the manufacturer of the machine or the vehicle that uses the engine.

Open Circuit – An open circuit is a condition that is caused by an open switch, or by an electrical wire or a connection that is broken. When this condition exists, the signal or the supply voltage can no longer reach the intended destination.

Parameter – A parameter is a value or a limit that is programmable. This helps determine specific characteristics or behaviors of the engine.

Password – A password is a group of numeric characters or a group of alphanumeric characters that is designed to restrict access to parameters. The electronic system requires correct passwords in order to change some parameters (Factory Passwords). Refer to Troubleshooting, “Factory Passwords” for more information.

Personality Module – See “Flash File”.

Power Cycling – Power cycling refers to the action of cycling the keyswitch from any position to the OFF position, and to the START/RUN position.

Primary Speed/Timing Sensor – This sensor determines the position of the crankshaft during engine operation. If the primary speed/timing sensor fails during engine operation, the secondary speed/timing sensor is used to provide the signal.

Pulse Width Modulation (PWM) – A PWM signal consists of pulses that are of variable width. These pulses occur at fixed intervals. The ratio of “TIME ON” versus total “TIME OFF” can be varied. This ratio is also referred to as a duty cycle.

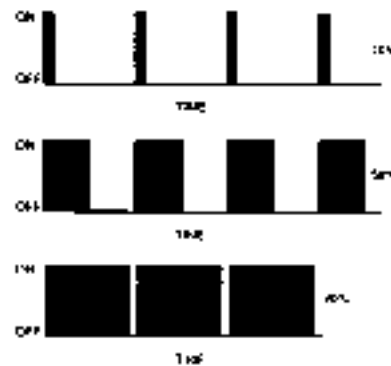

Illustration 2

g00284479

Rated Fuel Limit – This is a limit that is based on the power rating of the engine and on the engine rpm. The Rated Fuel Limit enables the engine power and torque outputs to conform to the power and torque curves of a specific engine model. These limits are in the flash file and these limits cannot be changed.

Reference Voltage – Reference voltage is a regulated voltage and a steady voltage that is supplied by the ECM to a sensor. The reference voltage is used by the sensor to generate a signal voltage.

Relay – A relay is an electromechanical switch. A flow of electricity in one circuit is used to control the flow of electricity in another circuit. A small current or voltage is applied to a relay in order to switch a much larger current or voltage.

Secondary Speed/Timing Sensor – This sensor determines the position of the camshaft during engine operation. If the primary speed/timing sensor fails during engine operation, the secondary speed/timing sensor is used to provide the signal.

Sensor – A sensor is a device that is used to detect the current value of pressure or temperature, or mechanical movement. The information that is detected is converted into an electrical signal.

Short Circuit – A short circuit is a condition that has an electrical circuit that is inadvertently connected to an undesirable point. An example of a short circuit is a wire which rubs against a vehicle frame and this rubbing eventually wears off the wire insulation. Electrical contact with the frame is made and a short circuit results.

Signal – The signal is a voltage or a waveform that is used in order to transmit information typically from a sensor to the ECM.

Supply Voltage – The supply voltage is a continuous voltage that is supplied to a component in order to provide the electrical power that is required for the component to operate. The power may be generated by the ECM or the power may be battery voltage that is supplied by the engine wiring.

System Configuration Parameters – System configuration parameters are parameters that affect emissions and/or operating characteristics of the engine.

Tattletale – Certain parameters that affect the operation of the engine are stored in the ECM. These parameters can be changed by use of the electronic service tool. The tattletale logs the number of changes that have been made to the parameter. The tattletale is stored in the ECM.

Throttle Position – The throttle position is the interpretation by the ECM of the signal from the throttle position sensor or the throttle switch.

Throttle Position Sensor – The throttle position sensor is a sensor that is usually connected to an accelerator pedal or a hand lever. This sensor sends a signal to the ECM that is used to calculate desired engine speed.

Top Center Position – The top center position refers to the crankshaft position when the No.1 piston position is at the highest point of travel. The engine must be turned in the normal direction of rotation in order to reach this point.

Total Tattletale – The total tattletale is the total number of changes to all the parameters that are stored in the ECM.

Wastegate – This is a device in a turbocharged engine that controls the maximum boost pressure that is provided to the inlet manifold.

Wastegate Regulator (if equipped) – The wastegate regulator controls the pressure in the intake manifold to a value that is determined by the ECM. The wastegate regulator provides the interface between the ECM and the mechanical system that regulates intake manifold pressure to the desired value that is determined by the software.

i04020489

Electronic Service Tools

Perkins electronic service tools are designed to help the service technician:

- Retrieve diagnostic codes.
- Diagnose electrical problems.
- Read parameters.
- Program parameters.
- Install trim files.

Required Service Tools

Table 1

Required Service Tools	
Part Number	Description
CH11155	Crimp Tool (12-AWG TO 18-AWG)
2900A019	Wire Removal Tool
27610285	Removal Tool
-	Suitable Digital Multimeter

Two short jumper wires are needed to check the continuity of some wiring harness circuits by shorting two adjacent terminals together in a connector. A long extension wire may also be needed to check the continuity of some wiring harness circuits.

Optional Service Tools

Table 2 lists the optional service tools that can be used when the engine is serviced.

Table 2

Part Number	Description
U5MK1092	Spoon Probe Kit(MULTIMETER)
- or -	Suitable Digital Pressure Indicator or Engine Pressure Group
-	Suitable Battery Load Tester
-	Suitable Temperature Adapter (MULTIMETER)
28170107	Bypass Harness As
2900A038	Harness As

Perkins Electronic Service Tool

The Perkins Electronic Service Tool can display the following information:

- Status of all pressure sensors and temperature sensors
- Programmable parameter settings
- Active diagnostic codes and logged diagnostic codes
- Active events and Logged events
- Histograms

The Electronic Service Tool can also be used to perform the following functions:

- Diagnostic tests
- Programming of flash files
- Parameter programming
- Copy configuration function for ECM replacement
- Data logging
- Graphs (real time)

Table 3 lists the service tools that are required in order to use the Electronic Service Tool.

Table 3

Service Tools for the Use of the Electronic Service Tool	
Part Number	Description
-(¹)	Single Use Program License
-(¹)	Data Subscription for All Engines
27610251	Communication Adapter (Electronic Service Tool to ECM interface)
27610164	Adapter Cable As

(¹) Refer to Perkins Engine Company Limited.

Note: For more information regarding the use of the Electronic Service Tool and the PC requirements for the Electronic Service Tool, refer to the documentation that accompanies your Perkins Electronic Service Tool software.

Connecting the Electronic Service Tool and the Communication Adapter II

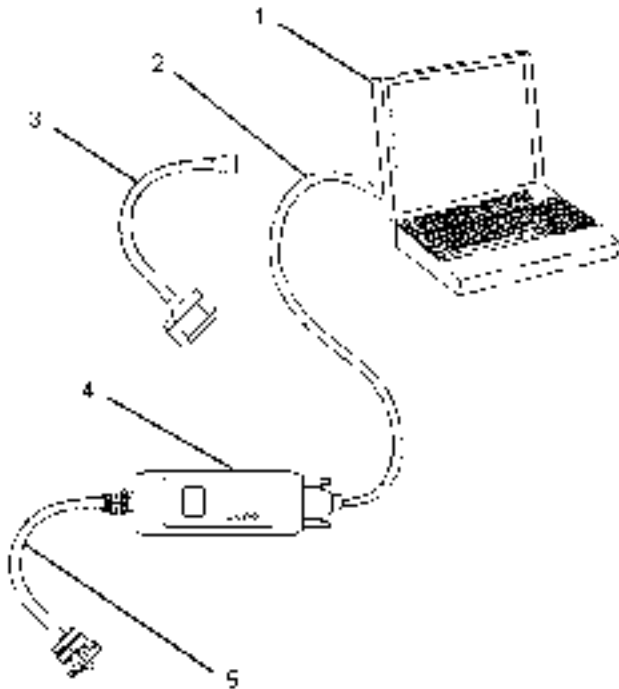

Illustration 3

g02194714

- (1) Personal Computer (PC)
- (2) Adapter Cable (Computer Serial Port)
- (3) Adapter Cable Assembly
- (4) Communication Adapter II
- (5) Adapter Cable Assembly

Note: Items (2), (3) and (4) are part of the Communication Adapter II kit.

Use the following procedure in order to connect the Electronic Service Tool and the Communication Adapter II.

1. Turn the keyswitch to the OFF position.
2. Connect cable (2) between the "COMPUTER" end of communication adapter (4) and the RS232 serial port of PC (1).

Note: The Adapter Cable Assembly (3) is required to connect to the USB port on computers that are not equipped with a RS232 serial port.

3. Connect cable (5) between the "DATA LINK" end of communication adapter (4) and the diagnostic connector.

4. Place the keyswitch in the ON position. If the Electronic Service Tool and the communication adapter do not communicate with the Electronic Control Module (ECM), refer to the diagnostic procedure Troubleshooting, "Electronic Service Tool Will Not Communicate With ECM".

i04012392

Indicator Lamps

Indicator Lamps

The functions of the indicator lamps are designed to display the maximum amount of information on the minimum number of lamps.

Seven lamps are available as options. The "Warning" lamp will normally be installed in the application. Dedicated optional lamps for other items may also be installed. The remaining optional lamps are "Low oil pressure", "Low coolant level", "High coolant temperature", "Maintenance clear" and "Water in fuel".

The "Warning" lamp and the "Diagnostic" lamp can also be used to indicate a diagnostic code by use of the "Flash Code" feature. The "Flash Code" feature can be used to indicate all active diagnostic codes and logged diagnostic codes.

Functions of the Lamps

Warning Lamp

Lamp check – When the keyswitch is turned to ON, the lamp will illuminate for 2 seconds. The lamp will then be extinguished unless there is an active warning.

Flashing – The lamp will be flashing when a "warning" or a "derate" is active.

Diagnostic Lamp

Lamp check – When the keyswitch is turned to ON, the lamp will illuminate for 2 seconds. The lamp will then be extinguished unless there is an active warning.

Flashing – The lamp will be flashing when a "diagnostic" or a "warning and derate" is active.

Low Oil Pressure

Lamp check – When the keyswitch is turned to ON, the lamp will illuminate for 2 seconds. The lamp will then be extinguished unless there is an active warning.

On – The lamp will illuminate when a low oil pressure event is detected. The “Warning” lamp and the “Diagnostic” lamp may also illuminate.

Low Coolant Level

Lamp check – When the keyswitch is turned to ON, the lamp will illuminate for 2 seconds. The lamp will then be extinguished unless there is an active warning.

On – The lamp will illuminate when a low coolant level event is detected. The “Warning” lamp and the “Diagnostic” lamp may also illuminate.

High Coolant Temperature

Lamp check – When the keyswitch is turned to ON, the lamp will illuminate for 2 seconds. The lamp will then be extinguished unless there is an active warning.

On – The lamp will illuminate when a high coolant temperature event is detected. The “Warning” lamp and the “Diagnostic” lamp may also illuminate.

Maintenance Clear

Lamp check – When the keyswitch is turned to ON, the lamp will illuminate for 2 seconds. The lamp will then be extinguished unless there is an active warning.

On – The lamp will illuminate when a maintenance clear event is detected. The “Warning” lamp and the “Diagnostic” lamp may also illuminate.

Water In Fuel

Lamp check – When the keyswitch is turned to ON, the lamp will illuminate for 2 seconds. The lamp will then be extinguished unless there is an active warning.

On – The lamp will illuminate when a water in fuel event is detected. The “Warning” lamp and the “Diagnostic” lamp may also illuminate.

Color of Lamps

Typically, the “Warning” lamp is colored red and the “Diagnostic” lamp is colored amber. The other lamps are optional.

Operation of the Indicator Lamps

Table 4

Diagnostic Lamp (Alert Lamp)	Warning Lamp (Action Lamp)	Lamp State	Description of the Indication	Engine State
On	On	Lamp Check	When the keyswitch is switched on, the lamps illuminate for 2 seconds and the lamps will then be extinguished.	The keyswitch is on but the engine has not yet been cranked.
Off	Off	No Faults	With the engine in operation, there are no active warnings, diagnostic codes, or event codes.	The engine is operating with no detected faults.
Flashing	Off	Active Diagnostic	If the diagnostic lamp illuminates during engine operation, this indicates that an active diagnostic code (an electrical fault) is present.	The engine is operating normally but there is one or more faults with the electronic management system for the engine.
Flashing	On	Warning (Warning only)	If the warning lamp illuminates during engine operation, this indicates that an active diagnostic code (a system fault) is present.	The engine is operating normally but there is one or more of the monitored engine parameters that are outside of the range that is acceptable.
Flashing	Flashing	Derate (Warning and Derate)	If both the warning lamp and diagnostic lamps flash during operation of the engine, the lamps indicate that one or more of the values for the engine protection strategy have been exceeded beyond the level that will cause an engine derate.	The engine is operating. However, one or more of the monitored engine parameters is outside of the acceptable range. The acceptable range has been exceeded to a level which requires a warning and an engine derate.

Flash Codes

The “Flash Code” feature is used to flash the code of all active diagnostic codes and logged diagnostic codes.

The sequence for the flash code is started by moving the keyswitch to “Off” and then moving the keyswitch to “On” twice within a period of 3 seconds. After a delay of 2 seconds, the “Warning” lamp will flash once for half a second. This sequence indicates the start of the active fault codes. After a further delay of 2 seconds, the “Diagnostic” lamp will flash repeatedly in order to indicate the active diagnostic codes. Each flash will be on for half a second and off for 300 milliseconds. The “Diagnostic” lamp will remain off for 2 seconds between each digit of a code. If there is more than one active diagnostic code, the “Warning” lamp will go off for 2 seconds. The lamp will then illuminate for half a second. The “Diagnostic” lamp will be extinguished for 2 seconds before starting the next code. If there are no active diagnostic codes, the “Diagnostic” lamp will flash the code “551”. Refer to Troubleshooting Guide, “No Diagnostic Code Detected”.

As an example, an active diagnostic code of “212” is indicated by the “Diagnostic” lamp coming on for 500 ms, then off for 300 ms, then on for 500 ms, then off for 2000 ms, then on for 500 ms, then off for 2000 ms, then on for 500 ms, then off for 300 ms, then on for 500 ms and then off.

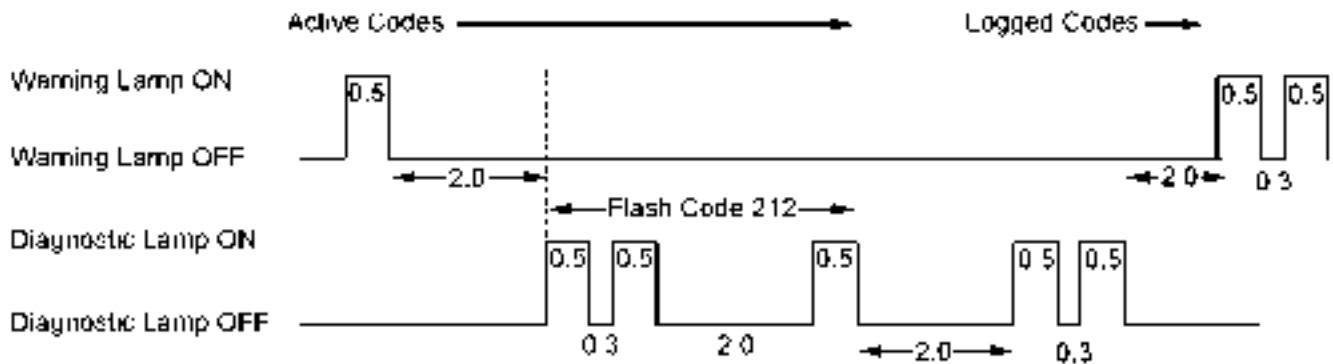

Note: All times shown in seconds

Illustration 4

g02188453

After all of the active diagnostic codes have been displayed, the "Warning" lamp will be extinguished for 2 seconds. The "Warning" lamp will flash twice in order to indicate the start of the sequence that will display the logged diagnostic codes. The process for flashing logged diagnostic codes is identical to the process for flashing active diagnostic codes.

Note: If there are no logged codes then the "551" code will be flashed again.

After all of the codes have been displayed, the "Warning" lamp will flash three times in order to indicate that there are no further codes. Cycling the keyswitch twice within a period of 3 seconds will start the process again. All codes will be displayed in ascending numerical order.

Refer to the Troubleshooting Guide, "Diagnostic Code Cross Reference" for the flash code that is related to the diagnostic code.

i04010409

Replacing the ECM

NOTICE

Care must be taken to ensure that fluids are contained during performance of inspection, maintenance, testing, adjusting and repair of the product. Be prepared to collect the fluid with suitable containers before opening any compartment or disassembling any component containing fluids.

Dispose of all fluids according to local regulations and mandates.

NOTICE

Keep all parts clean from contaminants.

Contaminants may cause rapid wear and shortened component life.

The engine is equipped with an Electronic Control Module (ECM). The ECM contains no moving parts. Follow the troubleshooting procedures in this manual in order to be sure that replacing the ECM will correct the fault. Verify that the suspect ECM is the cause of the fault.

Note: Ensure that the ECM is receiving power and that the ECM is properly grounded before replacement of the ECM is attempted. Refer to the Schematic Diagram.

A test ECM can be used in order to determine if the ECM on the engine is faulty. Install a test ECM in place of the suspect ECM. Install the flash file into the test ECM. Program the parameters for the test ECM. The parameters must match the parameters in the suspect ECM. Refer to the following test steps for details. If the test ECM resolves the fault, reconnect the suspect ECM. Verify that the fault returns. If the fault returns, replace the ECM.

Use the Electronic Service Tool to read the parameters in the suspect ECM. Record the parameters in the suspect ECM. Install the flash file into the test ECM. After the ECM is installed on the engine, the parameters must be programmed into the test ECM.

Note: When a test ECM is not available, you may need to remove an ECM from an engine that is not in service. The ECM must have the same serial number suffix. Ensure that the replacement ECM and the flash file match the suspect ECM. Be sure to record the parameters from the replacement ECM. Use the "Copy Configuration ECM Replacement" function in the Electronic Service Tool.

NOTICE

If the flash file and engine application are not matched, engine damage may result.

Perform the following procedure in order to replace the ECM.

1. Connect the Electronic Service Tool to the diagnostic connector.
2. Use the "Copy Configuration ECM Replacement" function from the Electronic Service Tool. If the "Copy Configuration" is successful, proceed to Step 4. If the "Copy Configuration" failed, proceed to Step 3.

Note: Record any Logged Faults and Events for your records.

3. Record the following parameters:
 - Record all of the parameters on the "Configuration" screen.
 - Record the serial numbers of the electronic unit injectors. The injector serial numbers are shown on the "Injector Trim Calibration" screen.

Note: If the parameters cannot be read, the parameters must be obtained elsewhere. Some parameters are stamped on the engine information plate, but most parameters must be obtained from the PTMI data on the Perkins Secured Internet.

4. Remove power from the ECM.
5. Remove the ECM.
6. Install the replacement ECM.
7. Download the flash file.
 - a. Connect the Electronic Service Tool to the diagnostic connector.
 - b. Select "WinFlash" from the "Utilities" menu of the electronic service tool.
 - c. Select the downloaded flash file.

8. If necessary, use the electronic service tool to clear the rating interlock. To clear the rating interlock, enter the factory password when the electronic service tool is first connected. Activating the "Test ECM" mode will also clear the rating interlock.
9. Use the electronic service tool to program the parameters. Perform the following procedure.
 - a. If the "Copy Configuration" procedure was successful, use the "Copy Configuration, ECM Replacement" function to load the configuration file into the ECM.

Note: During the following procedure, Factory Passwords may be required.

- b. If the "Copy Configuration" procedure failed, configure the parameters individually. The parameters should match the parameters from step 3.

Perform the "Fuel System Verification Test".

10. Check for logged diagnostic codes. Factory passwords are required to clear Logged Events.

103427341

Self-Diagnostics

The Electronic Control Module (ECM) has the ability to detect faults in the electronic system and with engine operation. When a fault is detected, a code is generated. An alarm may also be generated. There are two types of codes:

- Diagnostic
- Event

Diagnostic Code – When a fault in the electronic system is detected, the ECM generates a diagnostic code. This indicates the specific fault in the circuitry.

Diagnostic codes can have two different states:

- Active
- Logged

Active Code – An active diagnostic code indicates that an active fault has been detected by the control system. Active codes require immediate attention. Always service active codes prior to servicing logged codes.

Logged Code – Every generated code is stored in the permanent memory of the ECM. The codes are logged for 100 operating hours unless a code is cleared by use of the electronic service tool.

Event Code – An event code is generated by the detection of an abnormal engine operating condition. For example, an event code will be generated if the oil pressure is too low. In this case, the event code indicates the symptom of a fault.

Logged codes may not indicate that a repair is needed. The fault may have been temporary. The fault may have been resolved since the logging of the code. If the system is powered, it is possible to generate an active diagnostic code whenever a component is disconnected. When the component is reconnected, the code is no longer active. Logged codes may be useful to help troubleshoot intermittent faults. Logged codes can also be used to review the performance of the engine and the electronic system.

i04010410

Sensors and Electrical Connectors

The Electronic Control Module (ECM) and the sensors are located on the left side of the engine.

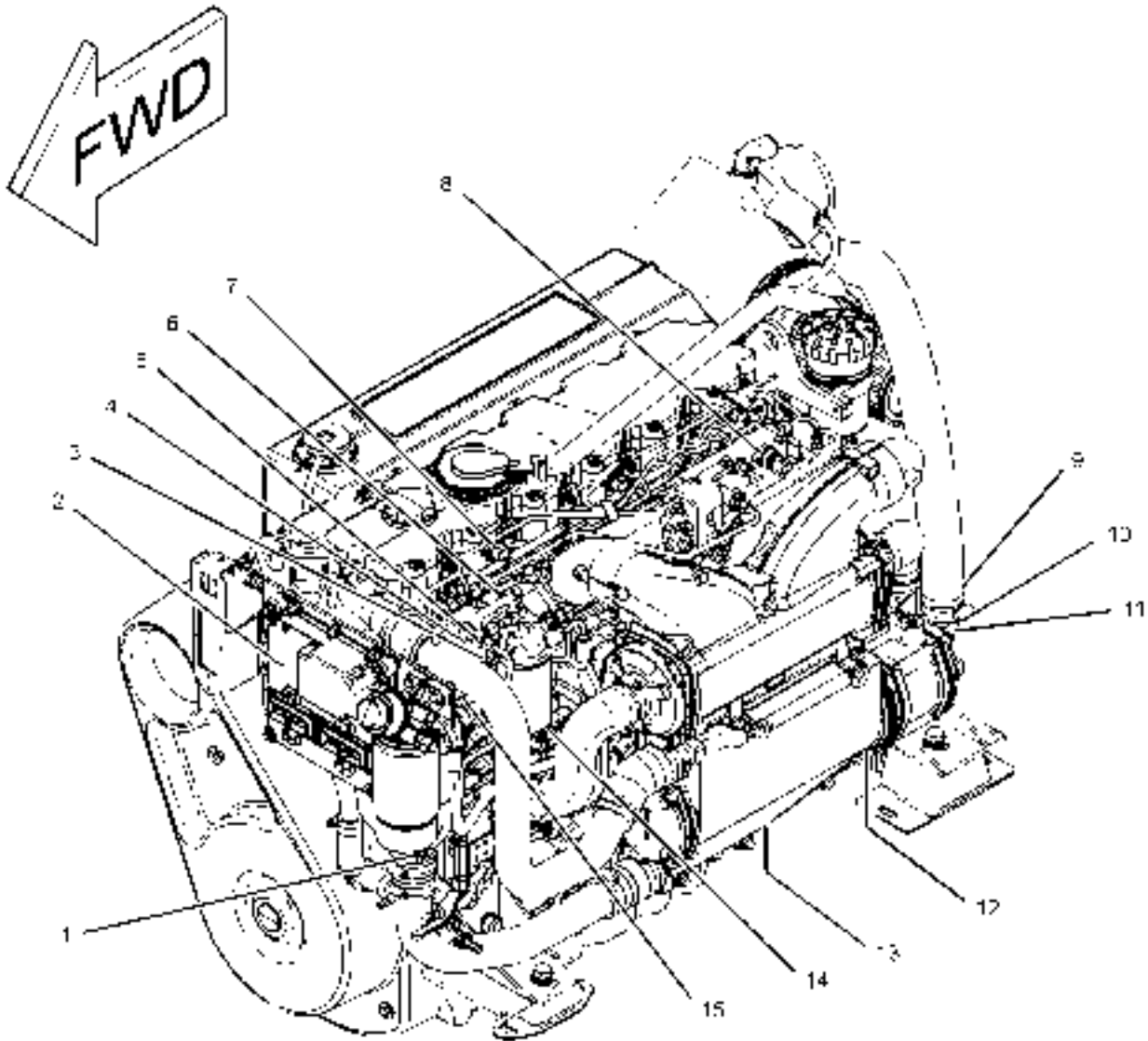

Illustration 5

g02186434

Typical example of the sensor locations on the engine

- | | | |
|--|---|--|
| (1) Water in fuel sensor | (6) Intake manifold air temperature sensor | (11) Transmission oil temperature sensor (if equipped) |
| (2) Electronic Control Module (ECM) | (7) Intake manifold pressure sensor | (12) Primary speed/timing sensor |
| (3) Fuel supply pressure sensor (if equipped) | (8) Fuel rail pressure Sensor | (13) Oil pressure sensor |
| (4) Coolant temperature sensor | (9) Fuel level sensor | (14) Secondary speed/timing sensor |
| (5) Fuel supply temperature sensor (if equipped) | (10) Transmission oil pressure sensor (if equipped) | (15) Solenoid for the fuel rail pump |

Note: If equipped, the wastegate regulator is installed on the right side of the engine.

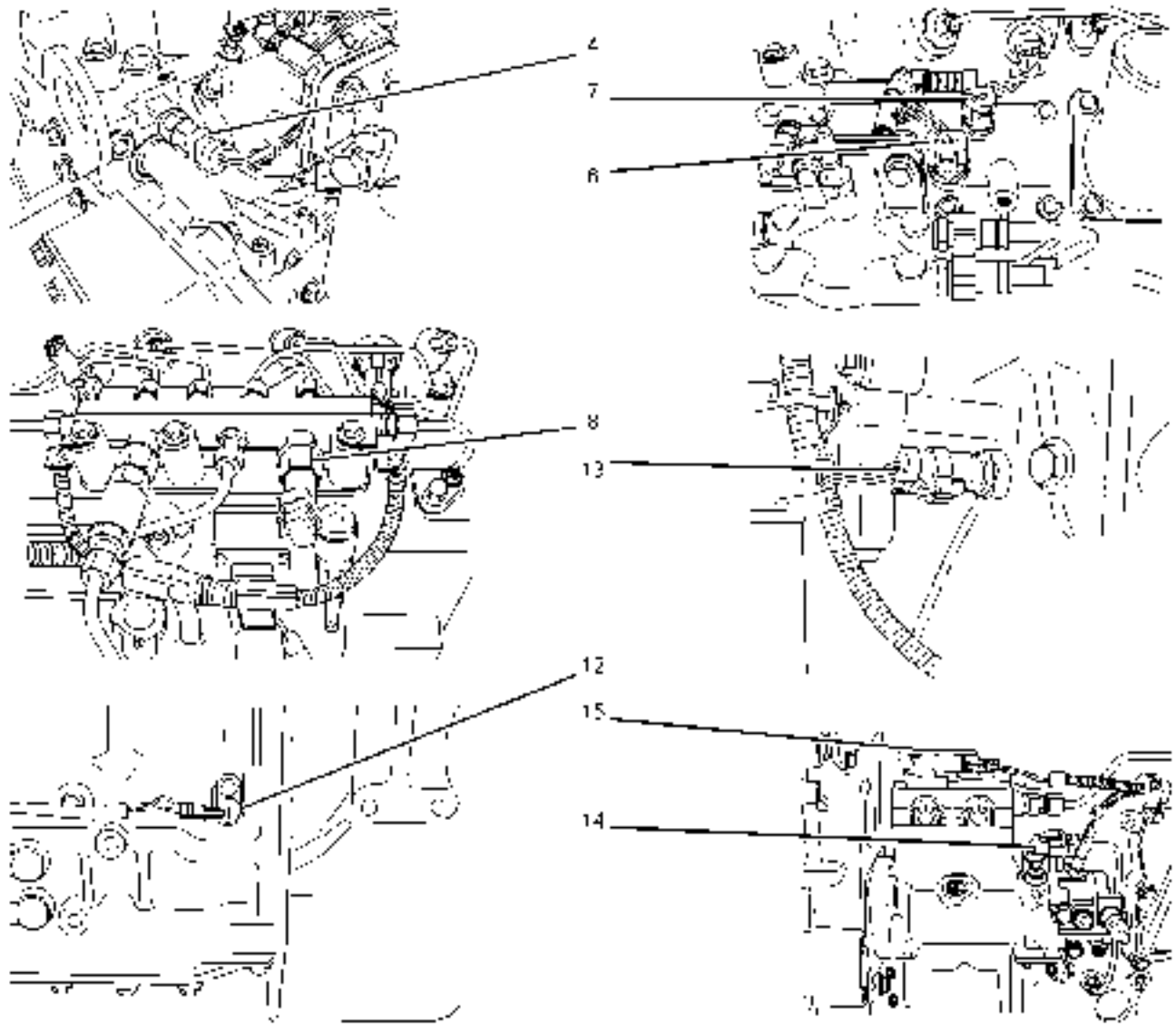

Illustration 6
Detailed views of the sensor locations on the engine

Table 5

Connector	Function
P1 (E-C1)	Customer Harness to ECM Connector (64 Pin Connector)
P2 (A-C1)	Engine Harness to ECM Connector (64 Pin Connector)
A-C2	Fuel Rail Pump Solenoid Connector (Two Pin Connector)
A-C3	Secondary Speed/Timing Sensor (Two Pin Connector)
A-C4	Primary Speed/Timing Sensor (Two Pin Connector)
A-C5	Engine Oil Pressure Sensor (Three Pin Connector)
A-C6	Fuel Rail Pressure Sensor (Three Pin Connector)
A-C7	Intake Manifold Pressure Sensor (Three Pin Connector)
A-C8	Intake Manifold Air Temperature Sensor (Two Pin Connector)
A-C9	Coolant Temperature Sensor (Two Pin Connector)
E-C3	Diagnostic Connector (if equipped)
A-C10	Electronic Unit Injectors for No. 1 and No. 2 Cylinders (Four Pin Connector)
A-C11	Electronic Unit Injectors for No. 3 and No. 4 Cylinders (Four Pin Connector)
A-C12	Electronic Unit Injectors for No. 5 and No. 6 Cylinders (Four Pin Connector)
A-C13	Wastegate regulator (if equipped) (Two Pin Connector)
A-C24	Fuel Temperature Sensor (if equipped) (Two Pin Connector)
A-C15	Fuel Level Sensor (if equipped) (Two Pin Connector)
A-C19	Transmission Oil Temperature Sensor (if equipped) (Two Pin Connector)
A-C18	Transmission Oil Pressure Sensor (if equipped) (Three Pin Connector)
A-C14	Fuel Supply Pressure Sensor (if equipped) (Three Pin Connector)
A-C16	Water In Fuel Sensor (if equipped) (Three Pin Connector)

i04010411

Engine Wiring Information

Harness Wire Identification

Perkins identifies all wires with eleven solid colors. The circuit number is stamped on the wire at a 25 mm (1 inch) spacing. Table 6 lists the wire colors and the color codes.

Table 6

Color Codes for the Harness Wire			
Color Code	Color	Color Code	Color
BK	Black	BU	Blue
BR	Brown	PU	Purple
RD	Red	GY	Gray
OR	Orange	WH	White
YL	Yellow	PK	Pink
GN	Green		

For example, a wire identification of T997-OR on the schematic would signify an orange wire with the circuit number F730. T997-OR identifies the power supply for the oil pressure sensor.

Note: Always replace a harness wire with the same gauge of wire and with the same color code.

Note: In the following diagrams, "Pxxx" signifies a plug and "Jxxx" signifies a jack.

Schematic Diagrams

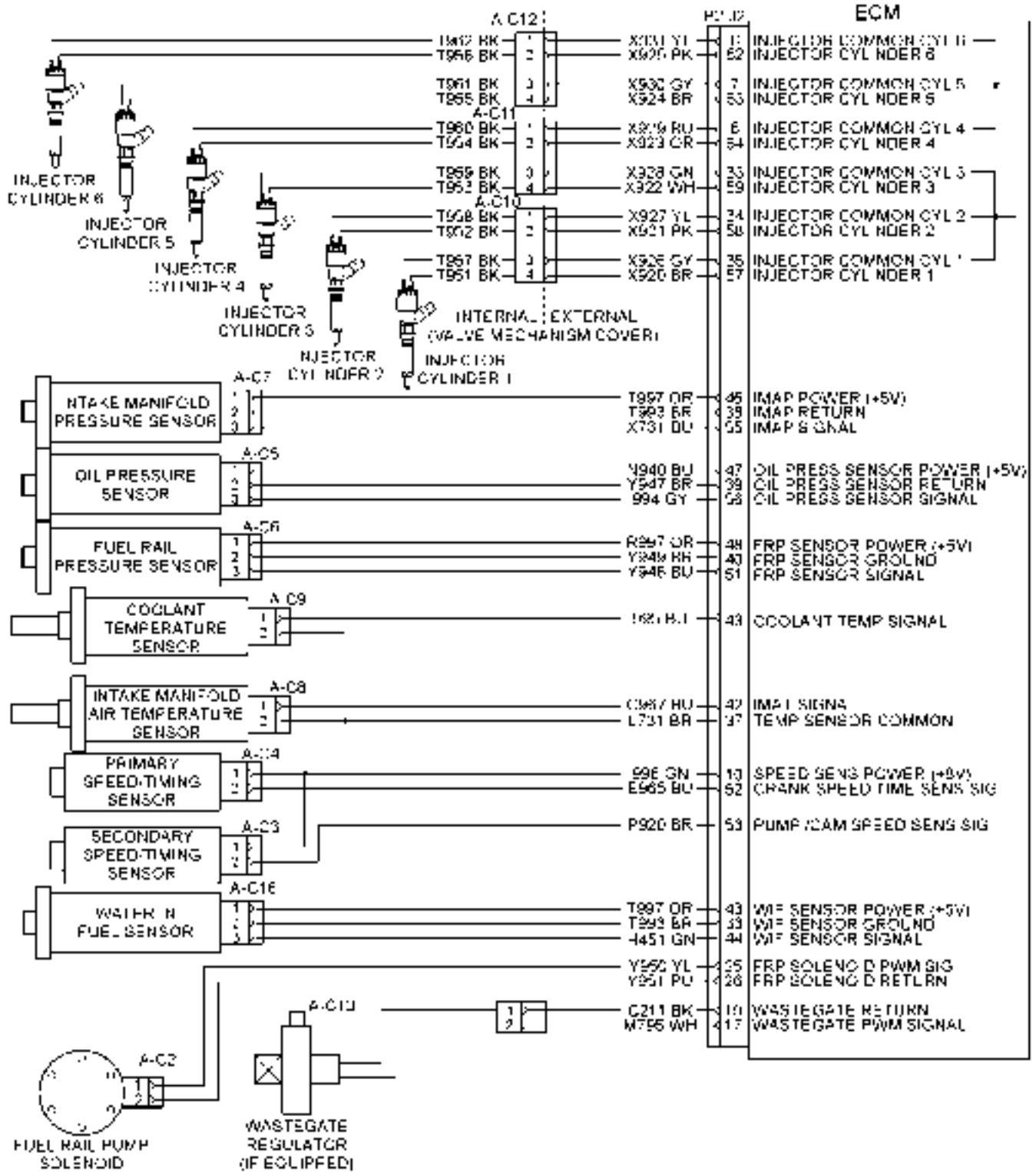

Illustration 7

Schematic Diagram for the engine Harness

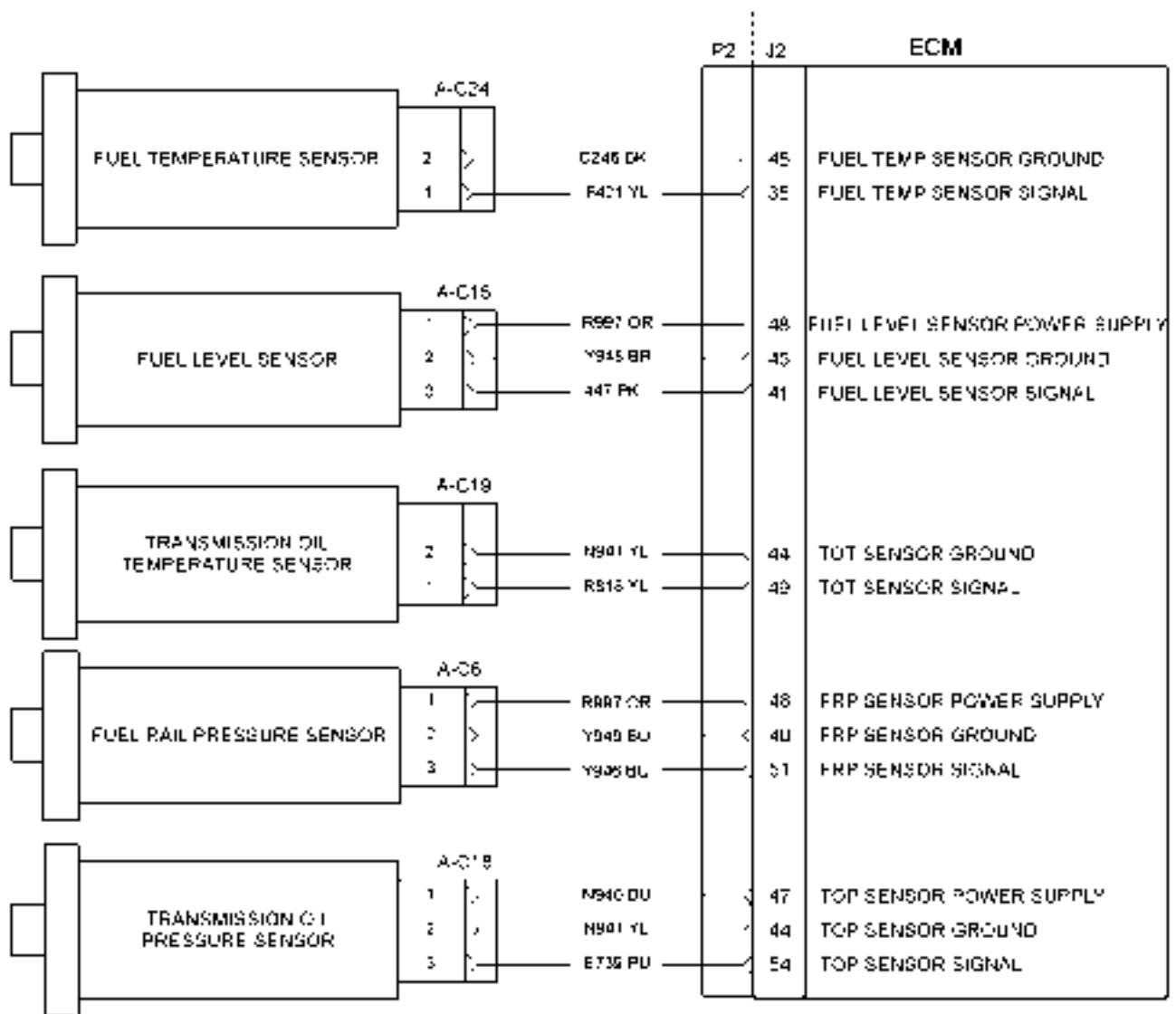

Illustration 8

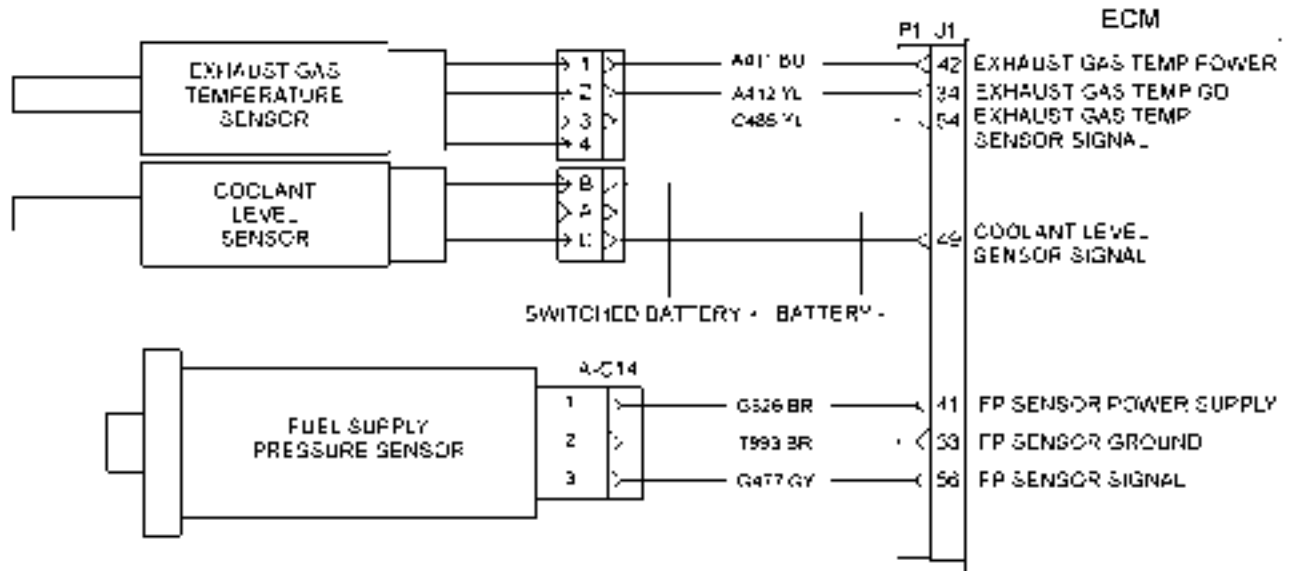

Illustration 9

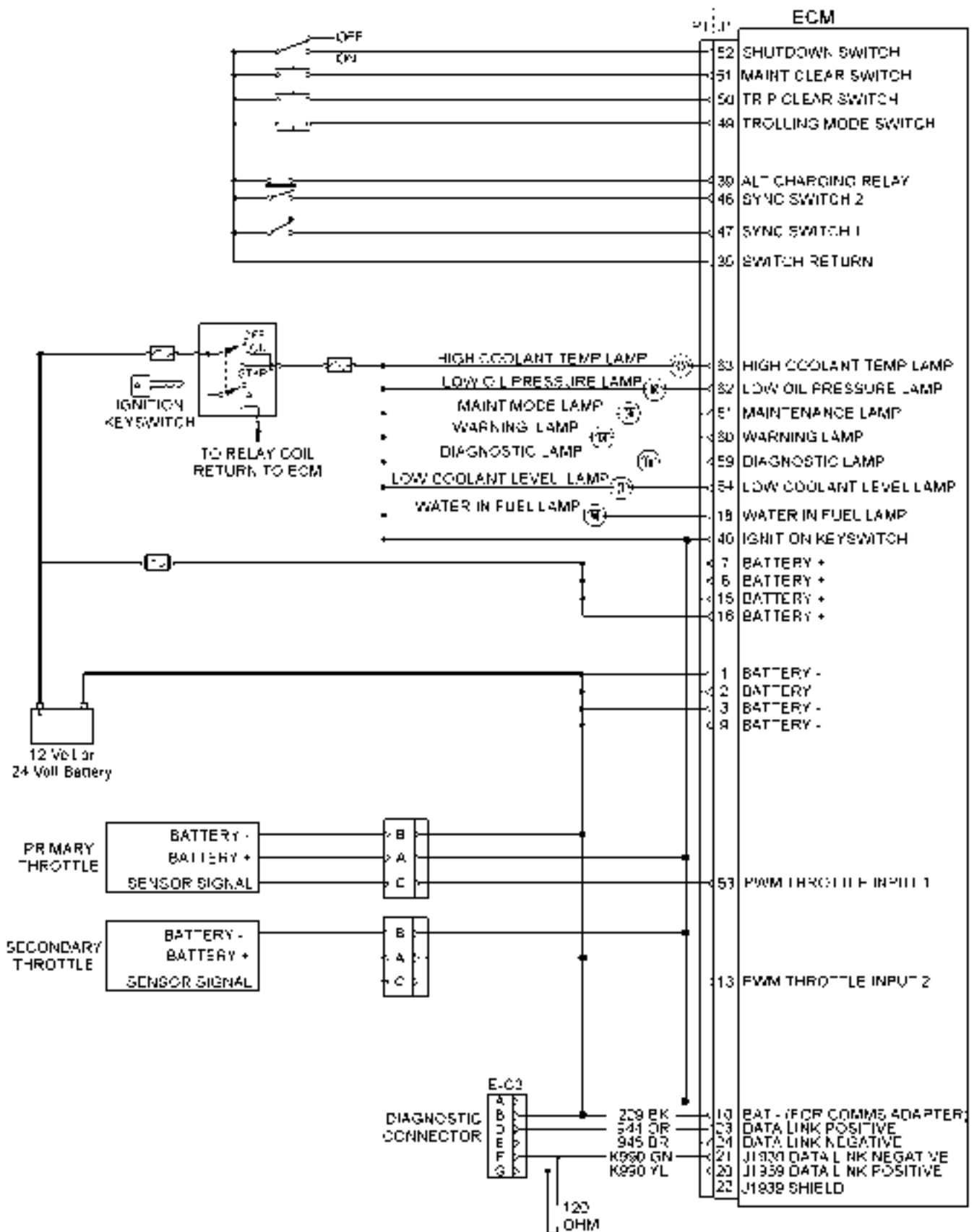

Illustration 10
Schematic Diagram for the application

i03434106

ECM Harness Connector Terminals

The Electronic Control Module (ECM) uses connectors that have 64 terminals to interface to the wiring harness.

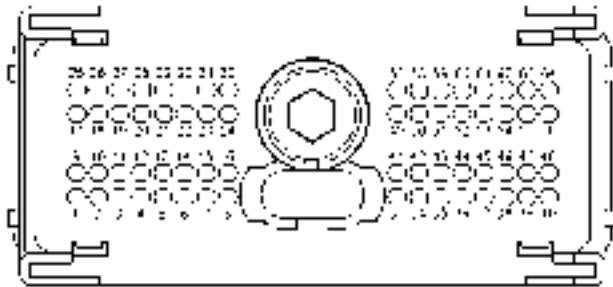

Illustration 11 g01784773
Layout of the Connector Pins (view from the rear)

Removal and Installation of the Harness Connector Terminals

Terminal Removal

Table 7

Required Tools		
Part Number	Part Description	Qty
27610285	Removal Tool	1

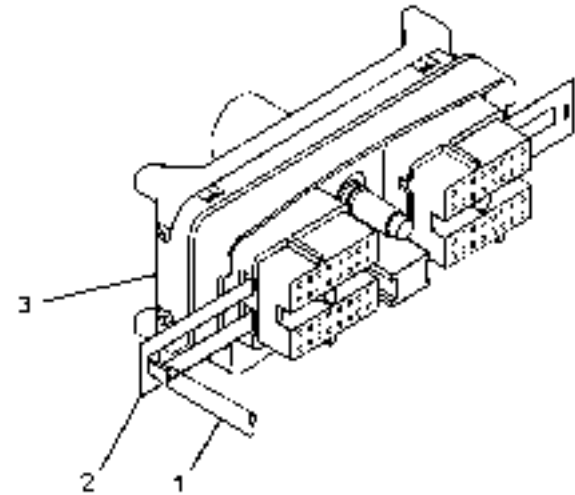

Illustration 12 g01784793
Removal of Terminal Position Assurance Components

1. Remove the connector from the ECM. Refer to Disassembly and Assembly, "Electronic Control Module - Remove and Install".
2. Use a screwdriver that has a flat blade (1) to remove the two terminal position assurance components (2) from the connector (3).

Note: Do not use the removal tool to remove the terminal position assurance components.

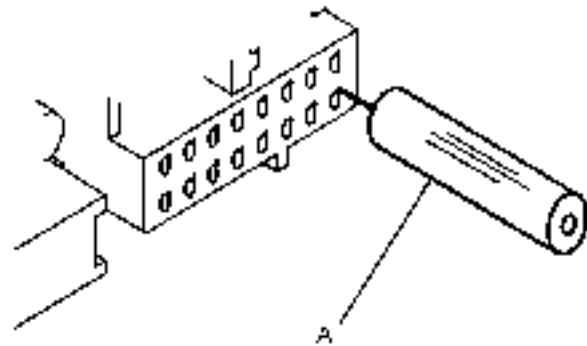

Illustration 13 g01784822
Removal Tool

3. Insert the removal tool into the hole that is adjacent to the terminal in order to release the locking device.
- Note:** Make sure that the tool stays perpendicular to the face of the connector.
4. Hold the tool in position and gently pull the wire in order to remove the terminal from the rear of the connector (3).

5. Remove the removal tool from the face of the connector (3).

Note: If a terminal must be replaced, part number 28170085 must be used.

Terminal Insertion

1. Push the terminal into the rear of the connector (3) until the terminal engages with the locking device.
2. Gently pull on the wire in order to make sure that the terminal is retained by the locking device.
3. Install the two terminal position assurance components (2) into the sides of the connector (3).
4. Connect the connector to the ECM. Refer to Disassembly and Assembly, "Electronic Control Module - Remove and Install".

Programming Parameters

i02415216

Programming Parameters

The electronic service tool can be used to view certain parameters that can affect the operation of the engine. The electronic service tool can also be used to change certain parameters. The parameters are stored in the Electronic Control Module (ECM). Some of the parameters are protected from unauthorized changes by passwords. Parameters that can be changed have a tattletale number. The tattletale number shows if a parameter has been changed.

i03434204

Test ECM Mode

“Test ECM Mode” is a feature in the software that can be used to help troubleshoot an engine that may have a fault in the Electronic Control Module (ECM). This feature allows a standard ECM to be used as a test ECM. This feature eliminates the need to stock a test ECM.

1. Search for the latest flash file for the engine.

Note: If a newer software version is available for the engine, install the newest software on the suspect ECM. If the new software does not rectify the fault, continue with this procedure.

2. Use the “Copy Configuration” feature on the electronic service tool to copy the parameters from the suspect ECM.

Note: If the “ECM Replacement” feature cannot be used, record the programmed values into the “Customer Specified Parameters Worksheet”. Also record the system configuration parameters.

3. Disconnect the suspect ECM. Temporarily connect the test ECM to the engine. Do not mount the test ECM on the engine.
4. Flash program the test ECM with the newest software that is available.
5. Start the “Test ECM Mode” on the electronic service tool. Access the feature through the “Service” menu. The electronic service tool will display the status of the test ECM and the hours that are remaining for the “Test ECM Mode”.

Note: “Test ECM Mode” can only be activated if the engine serial number has not already been programmed during normal operation of the ECM. If the engine serial number is programmed and the ECM is not in “Test ECM Mode”, the ECM can never be used as a test ECM.

6. Use the “Copy Configuration” feature on the electronic service tool to program the test ECM.

Note: If the “ECM Replacement” feature can not be used, program the test ECM with the values from the “Customer Specified Parameters Worksheet” and the values from the System Configuration Parameters.

7. Program the engine serial number into the test ECM.

Note: The “Test ECM Mode” must be activated before the engine serial number is programmed into the ECM.

8. Verify that the test ECM rectifies the fault.

When the “Test ECM Mode” is activated, an internal timer sets a 24 hour clock. This clock will count down only while the ECM is powered and the keyswitch is in the ON position. After the ECM has counted down the 24 hour period, the ECM will exit the “Test ECM Mode”. The parameters and the engine serial number will be set.

If the test ECM rectifies the fault, the engine can be released while the “Test ECM Mode” is still active.

Once an ECM has been activated in the “Test ECM Mode”, the ECM will stay in the “Test ECM Mode” until the timer times out. If the ECM is used as a test ECM for more than one engine, the “Test ECM Mode” must be reactivated. Anytime prior to the “Test ECM Mode” timing out, the ECM can be reset to 24 hours.

i03434261

Factory Passwords

NOTICE

Operating the engine with a flash file not designed for that engine will damage the engine. Be sure the flash file is correct for your engine.

Note: Factory passwords are provided only to Perkins dealers.

Factory passwords are required to perform each of the following functions:

- Program a new Electronic Control Module (ECM).

When an ECM is replaced, the system configuration parameters must be programmed into the new ECM. A new ECM will allow these parameters to be programmed once without factory passwords. After the initial programming, some parameters are protected by factory passwords.

- Rerate the engine.

This may require changing the interlock code, which is protected by factory passwords.

- Clear engine events and certain diagnostic codes.

Most engine events require factory passwords in order to clear the code from ECM memory. Clear these codes only when you are certain that a fault has been rectified. For example, the E362-1 Engine Overspeed requires the use of factory passwords in order to clear the code from ECM memory.

Since factory passwords contain alphabetic characters, the electronic service tool must be used to perform these functions. In order to obtain factory passwords, proceed as if you already have the password. If factory passwords are needed, the electronic service tool will request the factory passwords and the electronic service tool will display the information that is required to obtain the passwords.

i03807230

Flash Programming

Flash Programming – A method of loading a flash file into the Electronic Control Module (ECM)

The electronic service tool can be utilized to program a flash file into the ECM. The programming transfers the flash file from the PC to the ECM.

Flash Programming a Flash File

1. Obtain the part number for the new flash file.

Note: If you do not have the part number for the flash file, use "PTMI" on the Perkins Intranet.

Note: You must have the engine serial number in order to search for the part number for the flash file.

2. Connect the electronic service tool to the service tool connector.
3. Turn the keyswitch to the ON position. Do not start the engine.

4. Select "WinFlash" from the "Utilities" menu on the electronic service tool.

Note: If "WinFlash" will not communicate with the ECM, refer to Troubleshooting, "Electronic Service Tool Will Not Communicate with ECM".

5. Program the flash file into the ECM.

- a. Select the engine ECM under the "Detected ECMs".
- b. Press the "Browse" button in order to select the part number of the flash file that will be programmed into the ECM.
- c. When the correct flash file is selected, press the "Open" button.
- d. Verify that the "File Values" match the application. If the "File Values" do not match the application, search for the correct flash file.
- e. When the correct flash file is selected, press the "Begin Flash" button.
- f. The electronic service tool will indicate when programming has been successfully completed.

6. Start the engine and check for proper operation.

7. Access the "Configuration" screen under the "Service" menu in order to determine the parameters that require programming. Look under the "Tattletale" column. All of the parameters should have a tattletale of 1 or more. If a parameter has a tattletale of 0, program that parameter.

"WinFlash" Error Messages

If you receive any error messages during programming, click on the "Cancel" button in order to stop the process. Access the information about the "ECM Summary" under the "Information" menu. Ensure that you are programming the correct flash file for your engine.

i03434501

Injector Trim File

The electronic service tool is used to load the injector trim files into the Electronic Control Module (ECM).

The injector trim files must be loaded into the ECM if any of the following conditions occur:

- An electronic unit injector is replaced.

- The ECM is replaced.
- Diagnostic code 0268-02 is active.
- Electronic unit injectors are exchanged between cylinders.

Exchanging Electronic Unit Injectors

Exchanging electronic unit injectors can help determine if a fault is in the electronic unit injector or in the cylinder. If two electronic unit injectors that are currently installed in the engine are exchanged between cylinders, the injector trim files can also be exchanged. Press the “Exchange” button at the bottom of the “Injector Trim Calibration” screen on the electronic service tool. Select the two electronic unit injectors that will be exchanged and press the “OK” button. The tattletale for the electronic unit injectors that were exchanged will increase by one.

Note: The serial number for the electronic unit injector and the confirmation code number for the electronic unit injector are located on the electronic unit injector.

1. Record the serial number and the confirmation code number for each electronic unit injector.
2. Obtain the injector trim file by one of the following methods:
 - Select “Service Software Files” on the Perkins Internet.
 - Use the compact disc that is included with a replacement electronic unit injector.
3. Enter the serial number for the electronic unit injector in the search field.
4. Download the injector trim file to the PC. Repeat this procedure for each electronic unit injector, as required.
5. Connect the electronic service tool to the diagnostic connector. Refer to Troubleshooting, “Electronic Service Tools”.
6. Turn the keyswitch to the ON position.
7. Select the following menu options on the electronic service tool:
 - Service
 - Calibrations
 - Injector Trim Calibration
8. Select the appropriate cylinder.
9. Click on the “Change” button.

10. Select the appropriate injector trim file from the PC.

11. Click on the “Open” button.

12. If you are prompted by the electronic service tool, enter the confirmation code number for the electronic unit injector into the field.

13. Click on the “OK” button.

The injector trim file is loaded into the ECM.

14. Repeat the procedure for each cylinder, as required.

Customer Specified Parameters

i04012393

Customer Specified Parameters

Customer specified parameters allow the engine to be configured to the exact needs of the application.

Customer parameters may be changed repeatedly as a customer's operation changes.

The following information is a brief description of the customer specified parameters. The following parameter values are included with the descriptions:

- Minimum
- Maximum
- Default

Engine Rating Parameter

Rating Number

The rating number is the selected rating within a power rating family. The flash file defines the power rating family. The flash file contains two ratings. The rating number defines the power rating that is used within the power rating family.

Table 8

Minimum	Maximum	Default
1	2	1

Low Idle Parameters

Low Idle Speed

The "Low Idle Speed" is the minimum engine rpm.

Table 9

Minimum	Maximum	Default
600 rpm	750 rpm	600 rpm

ECM Identification Parameter

Equipment ID

"Equipment ID" is the identification of the equipment that is assigned by the customer. The "Equipment ID" is only for reference only by the customer. The "Equipment ID" is not required by the Electronic Control Module (ECM).

Table 10

Value	Default
17 digits The available characters are dependent on the service tool that is being used.	Not programmed

Configurable Inputs

Coolant Level Sensor

A coolant level sensor is an optional switch input. Programming the "Coolant Level Sensor" parameter to "Enabled" notifies the ECM that a coolant level sensor input is present on pin J1:45. If this parameter is programmed to "Enabled" and the coolant level falls below the measured level, the "E2143-1" and "E2143-2" event codes will be displayed.

Table 11

Value	Default
Installed Not Installed	Not Installed

Fuel/Water Separator Switch Installation Status

A fuel/water separator switch is an optional switch input. Programming the "Fuel/Water Separator Switch Installation Status" parameter to "Enabled" notifies the ECM that a fuel/water separator switch input is present on pin J1:44. When this parameter is programmed to "Enabled" and the fuel/water separator switch closes, an "E232-1" or "J97-15" event code will be displayed.

Table 12

Value	Default
Installed Not Installed	Installed

Exhaust Gas Temperature Sensor Installation Status

An exhaust gas temperature sensor is an optional sensor input. Programming the “Exhaust Gas Temperature Sensor Installation Status” parameter to “Enabled” notifies the ECM that an exhaust gas temperature sensor input is present on pin J1:54. When this parameter is programmed to “Enabled” and the exhaust gas temperature sensor goes above the measured level, an “E194-1” or “J173-15” event code will be displayed.

Table 13

Value	Default
Installed Not Installed	Not Installed

Transmission Oil Pressure Sensor Installation Status

A transmission oil pressure sensor is an optional sensor input. Programming the “Transmission Oil Pressure Sensor Installation Status” parameter to “Enabled” notifies the ECM that a transmission oil pressure sensor input is present on pin J2:54. When this parameter is programmed to “Enabled” and the transmission oil pressure sensor goes above the measured level, an “E113-1” or “J127-15” event code will be displayed.

Table 14

Value	Default
Installed Not Installed	Not Installed

Transmission Oil Temperature Sensor Installation Status

A transmission oil temperature sensor is an optional sensor input. Programming the “Transmission Oil Temperature Sensor Installation Status” parameter to “Enabled” notifies the ECM that a transmission oil temperature sensor input is present on pin J2:49. When this parameter is programmed to “Enabled” and the transmission oil temperature sensor goes above the measured level, an “E877-1” or “J177-15” event code will be displayed.

Table 15

Value	Default
Installed Not Installed	Not Installed

Fuel Pressure Sensor Installation Status

A fuel pressure sensor is an optional sensor input. Programming the “Fuel Pressure Sensor Installation Status” parameter to “Enabled” notifies the ECM that a fuel pressure sensor input is present on pin J1:56. When this parameter is programmed to “Enabled” and the fuel pressure sensor falls below the measured level, an “E198-1” or “J94-17” event code will be displayed.

Table 16

Value	Default
Installed Not Installed	Not Installed

Fuel Level Sensor Installation Status

A fuel level sensor is an optional sensor input. Programming the “Fuel Level Sensor Installation Status” parameter to “Enabled” notifies the ECM that a fuel level sensor input is present on pin J2:41. When this parameter is programmed to “Enabled” and the fuel level sensor falls below the measured level, an “E119-1” or “J96-17” event code will be displayed.

Table 17

Value	Default
Installed Not Installed	Not Installed

i04012394

Customer Specified Parameters Table

Table 18

Customer Specified Parameters		
ECM Parameter	Possible Values	Default Value
Engine Rating Parameter		
"Rating Number"	1 to 2	1
Low/High Idle Parameters		
"Low Idle Speed"	600 to 750 rpm	600 rpm
ECM Identification Parameter		
"Equipment ID"	17 Digits Available characters are dependent on the service tool that is used	Not Programmed
Configurable Inputs		
"Coolant Level Sensor Installation Status"	Not Installed Installed	Not Installed
"Fuel/Water Separator Switch Installation Status"	Not Installed Installed	Installed
"Exhaust Gas Temperature Installation Status"	Not Installed Installed	Not Installed
"Transmission Oil Pressure Sensor Installation Status"	Not Installed Installed	Not Installed
"Transmission Oil Temperature Sensor Installation Status"	Not Installed Installed	Not Installed
"Fuel Pressure Sensor Installation Status"	Not Installed Installed	Not Installed
"Fuel Level Sensor Installation Status"	Not Installed Installed	Not Installed
"Fuel Temperature Sensor Installation Status"	Not Installed Installed	Not Installed

i04012409

Customer Specified Parameters Worksheet

Table 19

Customer Specified Parameters Worksheet	
Engine Rating Parameter	
"Rating Numbers"	
Low Idle Parameters	
"Low Idle Speed"	
ECM Identifications Parameters	
"Equipment ID"	
Configurable Inputs	
"Coolant Level Sensor Installation Status"	
"Fuel/Water Separator Switch Installation Status"	
"Exhaust Gas Temperature Installation Status"	
"Transmission Oil Pressure Sensor Installation Status"	
"Transmission Oil Temperature Sensor Installation Status"	
"Fuel Pressure Sensor Installation Status"	
"Fuel Level Sensor Installation Status"	
"Fuel Temperature Sensor Installation Status"	

System Configuration Parameters

i03436280

System Configuration Parameters

System configuration parameters affect the emissions of the engine or the power of the engine. System configuration parameters are programmed at the factory. Normally, system configuration parameters would never need to be changed through the life of the engine. System configuration parameters must be reprogrammed if an Electronic Control Module (ECM) is replaced. System configuration parameters do not need to be reprogrammed if the ECM software is changed. Factory passwords are required to change these parameters. The following information is a description of the system configuration parameters.

Full Load Setting

The full load setting is a number that represents the adjustment to the fuel system that was made at the factory in order to fine tune the fuel system. If the ECM is replaced, the full load setting must be reprogrammed in order to prevent a 0268-02 diagnostic code from becoming active.

Full Torque Setting

Full torque setting is similar to full load setting. If the ECM is replaced, the full torque setting must be reprogrammed in order to prevent a 0268-02 diagnostic code from becoming active.

Rating Interlock

The rating interlock is a code that prevents the use of an incorrect power rating and/or emission rating for a specific engine. Each horsepower rating and each emission certification has a different code to all other horsepower ratings and emission certifications.

When an ECM is replaced, this rating interlock code must match the code that is stored in the ECM. If the rating interlock code does not match the code that is stored in the ECM, both of the following situations will exist:

- The engine will not run.
- Diagnostic code 0253-02 (Personality Module erratic, intermittent or incorrect) will be active.

Note: The flash programming of a new rating interlock replaces the old rating interlock.

This code does not need to be programmed when the replacement ECM is for the same engine rating.

If the ECM is for a different engine rating, then the following components may need to be changed: pistons, fuel injectors, and other components. The engine information ratings plate must also be changed in order to reflect the new rating.

Some systems such as the cooling system or the transmission may also require changes when the engine is rerated. Contact the application OEM for further information.

Engine Serial Number

When a new ECM is delivered, the engine serial number in the ECM is not programmed. The engine serial number should be programmed to match the engine serial number that is stamped on the engine information plate.

ECM Software Release Date

This parameter is defined by the rating interlock and this parameter is not programmable. The ECM software release date is used to provide the version of the software. The Customer parameters and the software change levels can be monitored by this date. The date is provided in the month and the year (DEC08). DEC is the month (December). 08 is the year (2008).

Troubleshooting without a Diagnostic Code

i04010429

Alternator Noise

Note: This is not an electronic system fault.

Probable Causes

- Alternator drive belt
- Alternator mounting bracket
- Automatic tensioner
- Alternator drive pulley
- Alternator bearings

Recommended Actions

Alternator Drive Belt

Inspect the condition of the alternator drive belt. If the alternator drive belt is worn or damaged, check that the drive belt and the pulley are correctly aligned. If the alignment is incorrect, investigate the cause of the misalignment. If the alignment is correct, replace the drive belt.

Alternator Mounting Bracket

Inspect the alternator mounting bracket for cracks and wear. Repair the mounting bracket or replace the mounting bracket in order to ensure that the alternator drive belt and the alternator drive pulley are in alignment.

Automatic Tensioner (if equipped)

Check the tension on the alternator drive belts. If necessary, replace the automatic tensioner (if equipped).

Alternator Drive Pulley

Remove the nut for the alternator drive pulley and then inspect the nut and the drive shaft. If no damage is found, install the nut and tighten the nut to the correct torque.

Alternator Bearings

Check for excessive play of the shaft in the alternator. Check for wear in the alternator bearings. The alternator is a non-serviceable item. The alternator must be replaced if the bearings are worn.

i04010431

Alternator Will Not Charge

Note: This is not an electronic system fault.

Note: The alternator is electronically monitored.

Probable Causes

- Alternator drive belt
- Automatic tensioner
- Charging circuit
- Alternator

Recommended Actions

Alternator Drive Belt

Inspect the condition of the alternator drive belt. If the alternator drive belt is worn or damaged, check that the drive belt for the alternator and the pulley are correctly aligned. If the alignment is incorrect, investigate the cause of the misalignment. If the alignment is correct, replace the drive belt.

Automatic Tensioner (if equipped)

Check the tension on the alternator drive belt. If necessary, replace the automatic tensioner (if equipped).

Charging Circuit

Inspect the battery cables, wiring, and connections in the charging circuit. Clean all connections and tighten all connections. Replace any faulty parts.

Alternator

Verify that the alternator is operating correctly. The alternator is not a serviceable item. If the alternator is not operating correctly, the alternator must be replaced.

i04010432

Battery

Note: The problem is not an electronic system problem.

Probable Causes

- Charging circuit
- Battery
- Auxiliary device

Recommended Actions

Charging Circuit

If a fault in the battery charging circuit is suspected, refer to Troubleshooting, "Alternator Will Not Charge".

Faulty Battery

1. Check that the battery is able to maintain a charge.
2. If the battery does not maintain a charge, replace the battery.

Auxiliary Device

1. Check that an auxiliary device has drained the battery by being left in the ON position.
2. Charge the battery.
3. Verify that the battery is able to maintain a charge when all auxiliary devices are switched off.

i04010433

Can Not Reach Top Engine RPM

Note: If this fault occurs only under load, refer to Troubleshooting, "Low Power/Poor or No Response to Throttle".

Probable Causes

- Diagnostic codes
- ECM parameters
- Throttle signal from the throttle position sensor

- Air intake and exhaust system
- Fuel supply
- Individual malfunctioning cylinders
- Electronic unit injectors

Recommended Actions

Diagnostic Codes

Check for active diagnostic codes on the electronic service tool. Troubleshoot any active codes before continuing with this procedure.

ECM Parameters

1. Ensure that the fault is not being caused by an incorrect programmed parameter.
2. Use the electronic service tool in order to ensure that the correct mode is selected.
3. Use the electronic service tool to verify the correct engine rating for the engine.
4. Use the electronic service tool to verify the maximum engine speed limit.
5. Use the electronic service tool to verify the following parameters at maximum speed: the boost pressure, the smoke limit, the torque limit, and the amount of fuel that is delivered.
6. Use the electronic service tool to reset the parameters to the OEM specifications.
7. Check that the repairs have eliminated the fault.
8. If the repairs have not eliminated the fault proceed to "Throttle Signal for the Throttle Position Sensor".

Throttle Signal for the Throttle Position Sensor

1. Use the electronic service tool and observe the signal for the throttle position sensor. Make sure that the throttle reaches the 100% raw position and the calibrated position.
2. If the signal is erratic, refer to Troubleshooting, "Digital Throttle Position Sensor Circuit - Test".
3. If the fault has not been eliminated, proceed to "Air Intake and Exhaust System".

Air Intake and Exhaust System

1. Check the air filter restriction indicator, if equipped.

2. Ensure that the air filter is clean and serviceable.
3. Check the air intake and the exhaust system for the following defects:
 - Blockages
 - Restrictions
 - Damage to the air intake and exhaust lines and hoses
4. Make all necessary repairs to the engine.
5. Ensure that the repairs have eliminated the fault.
6. If the fault has not been eliminated, proceed to "Fuel Supply".

Fuel Supply

1. Visually check the fuel tank for fuel. The fuel gauge may be faulty.
2. Ensure that the fuel supply valve is in the full OPEN position.
3. If the temperature is below 0 °C (32 °F), check for solidified fuel (wax).
4. Visually inspect the fuel supply lines for restrictions.
5. Check that the low-pressure fuel lines are tight and secured properly.
6. Remove the fuel filters. Inspect the fuel filters for contamination. Install new fuel filters. Determine the cause of the contamination.
7. Check the diesel fuel for contamination.
8. Check for air in the low-pressure fuel system.
9. Ensure that the fuel system has been primed.
10. Check the fuel pressure.

WARNING

Contact with high pressure fuel may cause fluid penetration and burn hazards. High pressure fuel spray may cause a fire hazard. Failure to follow these inspection, maintenance and service instructions may cause personal injury or death.

NOTICE

Contact with high pressure fuel may cause personal injury or death. Wait 60 seconds after the engine has stopped to allow fuel pressure to purge before any service or repair is performed on the engine fuel lines.

11. If the high-pressure fuel lines have a leak, the high-pressure fuel lines must be replaced.
12. If the repairs do not eliminate the fault, proceed to "Individual Malfunctioning Cylinders".

Individual Malfunctioning Cylinders

1. With the engine speed at a fast idle, use the electronic service tool to isolate one cylinder at a time. Note if there is any reduction in engine speed. If a reduction in engine speed is not noted, the isolated cylinder is not operating under normal conditions. If the isolation of a particular cylinder results in a reduction of engine speed that is less than normal, this may indicate that the cylinder is operating below normal performance. Investigate the cause of the fault on any cylinder that is not operating. Investigate the cause of the fault on any cylinder that is operating below normal performance.
2. If all cylinders have been checked and no faults were detected, proceed to "Electronic Unit Injectors".

Electronic Unit Injectors

1. With the engine speed at a fast idle, use the electronic service tool to isolate one cylinder at a time. Note if there is any reduction in engine speed. If a reduction in engine speed is not noted, the isolated electronic unit injector is not operating under normal conditions. If the isolation of a particular cylinder results in a reduction of engine speed that is less than normal, this may indicate that the electronic unit injector is operating below normal performance.
2. Remove the electronic unit injector from the suspect cylinder.
3. Install a new electronic unit injector.
4. Repeat the test in 1. If the fault is still apparent, remove the replacement electronic unit injector and install the original electronic unit injector.
5. If the fault is still apparent, carefully repeat the diagnostic process from the beginning.

104010435

Coolant in Engine Oil

Note: This is not an electronic system fault.

Probable Causes

- Engine oil cooler

i04010436

- Cylinder head gasket
- Cylinder head
- Cylinder block

Recommended Actions

Engine Oil Cooler

1. Drain the engine lubricating oil from the engine.
2. Check for leaks in the oil cooler assembly. If a leak is found, install a new oil cooler.

Cylinder Head Gasket

1. Remove the cylinder head.
2. Inspect the cylinder head gasket for faults and any signs of leakage.
3. If necessary, install a new cylinder head gasket.
4. If there was no obvious signs of a faulty head gasket proceed to "Cylinder Head".

Cylinder Head

1. Check the cylinder head for flatness.
2. Check the mating face of the cylinder head for faults and signs of leakage. If a fault is found, replace the cylinder head. If signs of leakage are found, determine the cause of the leakage.
3. Check the internal core plugs in the cylinder head for signs of leakage.
4. If the cylinder head is flat and if the cylinder head does not have any faults, refer to "Cylinder Block".

Cylinder Block

Inspect the top face of the cylinder block for faults and signs of leakage. If a fault is found, replace the cylinder block. If signs of leakage are found, determine the cause of the leakage.

Assembly after Repair

1. Install the cylinder head.
2. Remove the oil filter element. Install a new engine oil filter element. Fill the engine with clean engine oil to the correct level.

Coolant Temperature Is Too High

Note: This is not an electronic system fault.

Probable Causes

- Coolant level
- Coolant pressure relief valve
- Coolant temperature gauge
- Restriction in the coolant system
- Water temperature regulator
- Coolant pump
- Cylinder head gasket

Recommended Actions

Sea Water Strainer (if equipped)

Check the sea water strainer(if equipped) for dirt, debris, and/or damage. Remove any dirt and/or debris.

Coolant Level

1. Inspect the coolant level. If necessary, add coolant.
2. Check the cooling system for leaks. Repair any leaks immediately.

Pressure Relief Valve

1. Check that the seating surfaces of the pressure relief valve and the radiator cap are clean and undamaged.
2. Check operation of the pressure relief valve. If necessary, clean the components and/or replace the components.

Coolant Temperature Gauge

Compare the reading for the coolant temperature from the electronic service tool to the reading for the coolant temperature from a calibrated test gauge.

Restriction in the Coolant System

1. Visually inspect the cooling system for collapsed hoses and/or other restrictions.
2. Clean the radiator and flush the radiator.

Water Temperature Regulator

Check the water temperature regulator for correct operation. If necessary, replace the water temperature regulator.

Coolant Pump

1. Inspect the impeller of the coolant pump for damage and/or erosion.
2. Make sure that the drive gear is not loose on the drive shaft of the coolant pump.
3. If necessary, replace the coolant pump.

Auxiliary Coolant Pump (if equipped)

1. Inspect the impeller of the auxiliary coolant pump for damage and/or erosion.
2. Make sure that the drive gear is not loose on the drive shaft of the auxiliary coolant pump.
3. If necessary, replace the auxiliary coolant pump.

Cylinder Head Gasket

Switch off the engine and allow the engine to cool to below normal working temperature. Remove the pressure relief valve for the coolant system. Start the engine and inspect the coolant for the presence of bubbles. If bubbles are present in the coolant, combustion gases may be entering the cooling system. Check the cylinder head gasket. Refer to the recommended action for the cylinder head gasket within Troubleshooting, "Coolant in Engine Oil". Check the cylinder head for flatness. Install the pressure relief valve if there are no bubbles in the coolant.

i03807570

ECM Will Not Accept Factory Passwords

Probable Causes

One of the following items may not be recorded correctly on the electronic service tool:

- Passwords
- Serial numbers
- Total tattletale
- Reason code

Recommended Actions

1. Verify that the correct passwords were entered. Check every character in each password. Remove the electrical power from the engine for 30 seconds and then retry.
2. Verify that the electronic service tool is displaying the "Factory Password" screen.
3. Use the electronic service tool to verify that the following information has been entered correctly:
 - Engine serial number
 - Serial number for the electronic control module
 - Serial number for the electronic service tool
 - Total tattletale
 - Reason code

i04022030

ECM Will Not Communicate with Other Systems or Display Modules

Probable Causes

- Electrical connectors
- Electronic Control Module (ECM)

Recommended Actions

1. Connect the electronic service tool to the diagnostic connector. If the ECM does not communicate with the electronic service tool, refer to Troubleshooting, "Electronic Service Tool Will Not Communicate with ECM".
2. Ensure that the following items are correctly installed and undamaged. Refer to Troubleshooting, "Electrical Connectors - Inspect".
 - P1/J1 and P2/J2 connectors on the ECM

- Wiring to display modules
 - Wiring to other control modules
3. Troubleshoot the Perkins Data Link for possible faults. Refer to Troubleshooting, "Data Link Circuit - Test".
 4. Troubleshoot the CAN Data Link for possible faults. Refer to Troubleshooting, "CAN Data Link Circuit - Test".

i03807610

Electronic Service Tool Will Not Communicate with ECM

Probable Causes

- Configuration for the communications adapter
- Electrical connectors
- Communication adapter and/or cables
- Electrical power supply to the diagnostic connector
- Electronic service tool and related hardware
- Electrical power supply to the Electronic Control Module (ECM)
- Data link

Recommended Actions

Start the engine. If the engine starts, but the ECM will not communicate with the electronic service tool, continue with this procedure. If the engine will not start, refer to Troubleshooting, "Engine Cranks but Will Not Start". If the engine will not crank, refer to Troubleshooting, "Engine Will Not Crank".

Configuration for the Communications Adapter

1. Access "Preferences" under the "Utilities" menu on the electronic service tool.
2. Verify that the correct "Communications Interface Device" is selected.
3. Verify that the correct port is selected for use by the communication adapter.

Note: The most commonly used port is "COM 1".

4. Check for any hardware that is utilizing the same port as the communications adapter. If any devices are configured to use the same port, exit or close the software programs for that device.

Electrical Connectors

Check for correct installation of the P1/J1 and P2/J2 ECM connectors and of the diagnostic connector. Refer to Troubleshooting, "Electrical Connectors - Inspect".

Communication Adapter and/or Cables

1. Make sure that the firmware and driver files are the most current files that are available for the type of communication adapter that is being used. If the firmware and driver files do not match, the communication adapter will not communicate with the electronic service tool.
2. Disconnect the communication adapter and the cables from the diagnostic connector. Reconnect the communication adapter to the diagnostic connector.
3. Verify that the correct cable is being used between the communication adapter and the diagnostic connector. Refer to Troubleshooting, "Electronic Service Tools".
4. If the laptop computer is using a Windows operating system, restart the laptop computer in order to eliminate the possibility of a conflict in the software.

Electrical Power Supply to the Diagnostic Connector

Verify that battery voltage is present between terminals A and B of the diagnostic connector. If the communication adapter is not receiving power, the LED display on the communication adapter will not be illuminated.

Electronic Service Tool and Related Hardware

In order to eliminate the electronic service tool and the related hardware as the cause of the fault, connect the electronic service tool to a different engine. If the same fault occurs on a different engine, check the electronic service tool and the related hardware in order to determine the cause of the fault.

Electrical Power Supply to the Electronic Control Module (ECM)

Check power to the ECM. Refer to Systems Operation, Testing and Adjusting, "Charging System - Test".

Note: If the ECM is not receiving battery voltage, the ECM will not communicate.

Data Link

Troubleshoot the data link for possible faults. Refer to Troubleshooting, "Data Link Circuit - Test".

i04010438

Engine Cranks but Will Not Start

Probable Causes

- Diagnostic codes
- Visible faults
- Starting circuit
- Starting aids (if applicable)
- Air shutoff system (if applicable)
- Air intake and exhaust system
- Primary speed/timing sensor
- Low-pressure fuel system
- Secondary speed/timing sensor
- High-pressure fuel system
- Glow plugs
- Valve lash
- Low compression (cylinder pressure)

Recommended Actions

NOTICE

Do not crank the engine continuously for more than 30 seconds. Allow the starting motor to cool for two minutes before cranking the engine again.

Diagnostic Codes

Use one of the following methods to check for active diagnostic codes:

- The display on the control panel
- The electronic service tool

Display on the Control Panel

Note: The following procedure is only applicable if the application is equipped with a display on the control panel.

1. Check the display on the control panel for active diagnostic codes.
2. Troubleshoot any active codes before continuing with this procedure. Refer to Troubleshooting, "Troubleshooting with a Diagnostic Code".
3. Attempt to start the engine. If the engine will not start, proceed to "Visible Faults".

Electronic Service Tool

1. Connect the electronic service tool to the diagnostic connector.
2. Check for active diagnostic codes on the electronic service tool.
3. Troubleshoot any active codes before continuing with this procedure. Refer to Troubleshooting, "Troubleshooting with a Diagnostic Code".
4. Attempt to start the engine. If the engine will not start, proceed to "Visible Faults".

Visible Faults

1. Visually inspect the engine for the following faults:
 - Missing components
 - Damaged components
 - Damaged electrical cables or loose electrical cables
 - Oil leaks
 - Fuel leaks
2. Check the following items:
 - Check for smoke from the exhaust when the engine is cranking. If smoke is seen during cranking, there may be a mechanical fault in the engine. Refer to "Low Compression (Cylinder Pressure)".
 - Check for the proper level of fuel, oil, and coolant.
 - Ensure that the fuel supply valve (if equipped) is in the full OPEN position.
 - If the ambient temperature is below 0 °C (32 °F), make sure that the correct specification of engine oil and oil for the machine is used.
 - Check that the battery voltage is correct.

- Use the electronic service tool to check the average cranking speed of the engine. If the cranking speed is less than 150 rpm, investigate the cause of the low cranking speed.
 - Make sure that all fuel filters are correctly installed.
 - Drain any water from the primary fuel filter/water separator.
3. Rectify any faults that are found during the visual checks.
 4. Attempt to start the engine. If the engine will not start, proceed to “Air Intake and Exhaust System”.

Air Intake and Exhaust System

1. Check the air filter restriction indicator, if equipped.
2. Ensure that the air filter is clean and serviceable.
3. Check the air intake and exhaust systems for the following defects:
 - Blockages
 - Restrictions
 - Damage to lines or hoses
4. Repair any defects before attempting to restart the engine.
5. Attempt to start the engine. If the engine will not start, proceed to “Primary Speed/timing Sensor”.

Primary Speed/timing Sensor

1. Disconnect connector A-C4 from the primary speed/timing sensor.
2. Attempt to start the engine.
3. If the engine starts, check for a fault in the circuit for the primary speed/timing sensor. Refer to Troubleshooting, “Engine Speed/Timing Sensor Circuit - Test”.
4. If the engine does not start, inspect the timing ring on the crankshaft for misalignment.
5. If necessary, replace the crankshaft timing ring.
6. Attempt to start the engine. If the engine will not start, proceed to “Low Pressure Fuel System”.

Low Pressure Fuel System

1. If the temperature is below 0 °C (32 °F), check for solidified fuel (wax).

2. Check for fuel supply lines that are restricted.
3. Check that the low-pressure fuel lines are correctly installed.
4. Check the diesel fuel for contamination.
5. Check for air in the fuel system.
6. Ensure that the fuel system has been primed.
7. Attempt to start the engine. If the engine will not start, continue with this procedure.
8. Replace the primary fuel filter and the secondary fuel filter.
9. Attempt to start the engine. If the engine will not start, continue with this procedure.
10. Check the flow of fuel through the transfer pump. If the flow of fuel through the transfer pump is less than 250 mL per minute at 150 rpm, replace the transfer pump.
11. Attempt to start the engine. If the engine will not start, proceed to “Secondary Speed/timing Sensor”.

Secondary Speed/timing Sensor

1. Connect the electronic service tool to the diagnostic connector.
2. Check that the desired fuel rail pressure is at least 25 MPa (3625 psi) when the engine is cranking.
3. If the desired fuel rail pressure is less than 25 MPa (3625 psi), perform the following procedure:
 - a. Use the electronic service tool to check the signal from the secondary speed/timing sensor while the engine is cranking.
 - b. If the signal from the secondary speed/timing sensor is 0 rpm, investigate the secondary speed/timing sensor. Refer to Troubleshooting, “Engine Speed/Timing Sensor Circuit - Test”.
 - c. If a fault is identified in the circuit for the secondary speed/timing sensor, repair the fault and then attempt to start the engine. If the engine will not start, proceed to “High Pressure Fuel System”.
 - d. If the signal from the secondary speed/timing sensor is greater than 0 rpm and the engine will not start, proceed to “High Pressure Fuel System”.

High Pressure Fuel System

1. Use the electronic service tool to check the absolute fuel rail pressure while the engine is cranking at a minimum speed of 150 rpm.
2. If the absolute fuel rail pressure is less than 25 MPa (3625 psi), perform the following procedure:
 - a. Check that the inlet pressure at the fuel rail pump is greater than 50 kPa (7.25 psi). If the inlet pressure is less than 50 kPa (7.25 psi), repeat the diagnostic process from "Low Pressure Fuel System".
 - b. Check for fuel leaks in the high-pressure fuel system. Rectify any fuel leaks and then recheck the pressure in the fuel rail. If the fuel rail pressure is greater than 25 MPa (3625 psi), proceed to test step 3.
 - c. Use the electronic service tool to perform a solenoid test on the fuel rail pump. Refer to Troubleshooting, "Fuel Rail Pump Solenoid - Test".
 - d. If any service has been performed as a result of Step 2.c, attempt to start the engine. If the engine will not start, repeat the diagnostic process from "Diagnostic Codes".
 - e. Check the pressure relief valve in the fuel rail for leakage. If the pressure relief valve is leaking, replace the valve and recheck the pressure in the fuel rail.
 - f. If the pressure relief valve in the fuel rail is not leaking, check for fuel in the engine oil system. If fuel is suspected in the oil system, take an engine oil sample for analysis. If the analysis confirms that there is fuel in the engine oil system, investigate the cause.
 - g. If fuel is not found in the oil system, check the electronic unit injectors for excessive fuel leak off.
 - h. If the leak off is greater than 38 mL (1.3 oz) in 30 seconds for a 6 cylinder engine, replace the electronic unit injectors.
3. If the absolute fuel rail pressure is greater than 25 MPa (3625 psi), perform the following procedure:
 - i. If the leak off is less than 38 mL (1.3 oz) in 30 seconds for a 6 cylinder engine, proceed to Test Step 3.d.

- a. Use the electronic service tool to make sure that the status of the electronic unit injectors is not "Disabled". If the injectors are disabled but the injectors were not intentionally disabled with the electronic service tool, proceed to test step 3.d.
- b. If the electronic unit injectors are not disabled, use the electronic service tool to perform an injector solenoid test. Refer to Troubleshooting, "Injector Solenoid Circuit - Test".
- c. If any service has been performed as a result of Step 3.b, attempt to start the engine. If the engine will not start, proceed to "Glow Plugs".
- d. Make sure that the latest flash file for the application is installed in the ECM. Refer to Troubleshooting, "Flash Programming".
- e. Consult a Perkins dealer.

Note: This consultation can greatly reduce the repair time.

- f. If the Perkins dealer recommends the use of a test ECM, install a test ECM. Refer to Troubleshooting, "Replacing the ECM".
- g. Attempt to start the engine. If the engine will not start, install the original ECM and then proceed to Test Step 3.i.
- h. If the engine starts normally, stop the engine and then attempt to start the engine again. If the engine will not start at the second attempt, proceed to Test Step 3.k.
- i. If the engine starts normally, reconnect the suspect ECM and then verify that the fault returns when the suspect ECM is installed.
- j. If the engine will not start with the suspect ECM, replace the ECM. Check that the engine starts normally. If the engine starts normally, no further testing is required.
- k. Replace the ECM again and then replace the fuel rail pump. Verify that the fault has been eliminated. If the engine will not start, proceed to "Glow Plugs".
- l. Check the timing of the fuel rail pump.
- m. If the timing of the fuel rail pump required adjustment and the engine will not start, proceed to "Glow Plugs".
- n. If the timing of the fuel rail pump was correct, replace the fuel rail pump. If the engine will not start, proceed to "Glow Plugs".

Glow Plugs

Note: Faulty glow plugs will only affect engine starting when the ambient temperature is below 5° C (41° F).

1. Check the operation of the glow plugs.
2. If necessary, replace faulty glow plugs.
3. Attempt to start the engine. If the engine will not start, proceed to "Valve Lash".

Valve Lash

1. Check the valve lash.
2. Attempt to start the engine. If the engine will not start, proceed to "Low Compression (Cylinder Pressure)".

Low Compression (Cylinder Pressure)

1. Perform a compression test.
2. If low compression is noted on any cylinders, investigate the cause and rectify the cause.

Possible causes of low compression are shown in the following list:

- Loose glow plugs
- Faulty piston
- Faulty piston rings
- Worn cylinder bores
- Worn valves
- Faulty cylinder head gasket
- Damaged cylinder head

3. Perform all necessary repairs.
4. Ensure that the repairs have eliminated the fault.

i04010444

Engine Has Early Wear

Note: This is not an electronic system fault.

Probable Causes

- Multiple starts or cold operation
- Incorrect maintenance intervals

- Dirt in engine oil
- Incorrect oil
- Contaminated oil
- Leaks in air intake system
- Dirt in fuel
- Low oil pressure

Recommended Actions

Multiple Starts or Cold Operation

Frequent starting and stopping of the engine can cause early wear. Also, operation of the engine for short periods of time in cold conditions can cause early wear.

Incorrect Maintenance Intervals

If the engine is not correctly maintained, early wear will occur.

Make sure that the engine is maintained at the correct maintenance intervals.

Dirt in Engine Oil

1. Drain the oil from the crankcase and refill the crankcase with clean engine oil. Install new engine oil filters.

Incorrect Oil

1. Check that the engine is filled with oil of the correct specification.
2. If necessary, drain the engine oil system and refill the engine oil system.

Contaminated Oil

Check an oil sample for contamination with fuel. If contamination is found, investigate the cause.

Leaks in Air Intake System

A leak in the air intake system may allow unfiltered air into the engine. Inspect the air intake system for streaks which may indicate a leakage of unfiltered air. Inspect all of the gaskets and the connections. Repair any leaks.

Dirt in Fuel

1. Remove the fuel filters. Inspect the fuel filters for contamination. Install new fuel filters. Determine the cause of the contamination.

2. Check the diesel fuel for contamination.

Low Oil Pressure

Refer to Troubleshooting, "Low Engine Oil Pressure" for the testing procedure. Repair any identified faults.

i04010450

Engine Misfires, Runs Rough or Is Unstable

Note: If the fault is intermittent and the fault cannot be duplicated, refer to Troubleshooting, "Intermittent Low Power or Power Cutout".

Note: If the fault only occurs under certain conditions, test the engine under those conditions. Examples of certain conditions are high rpm, full load, and engine operating temperature. Troubleshooting the symptoms under other conditions can give misleading results.

The probable root causes are listed in order below:

Probable Causes

- Diagnostic codes
- Throttle position sensor
- Air intake and exhaust system
- Fuel supply
- Fuel rail pump
- Low compression (cylinder pressure)
- Individual malfunctioning cylinder
- Electronic unit injectors

Recommended Actions

Diagnostic Codes

Check for active diagnostic codes on the electronic service tool. Troubleshoot any active codes before continuing with this procedure.

Throttle Position Sensor

1. Use the electronic service tool and observe the signal for the throttle position sensor. The status should be 0 percent at low idle and the status should be 100 percent at high idle.

2. If the signal is erratic, refer to Troubleshooting, "Digital Throttle Position Sensor Circuit - Test".
3. If the repairs do not eliminate the fault proceed to "Air Intake and Exhaust System".

Air Intake and Exhaust System

1. Check the air filter restriction indicator, if equipped.
2. Ensure that the air filter is clean and serviceable.
3. Check the air intake and exhaust systems for the following defects:
 - Blockages
 - Restrictions
 - Damage to lines or hoses
4. If the repairs do not eliminate the fault proceed to "Fuel Supply".

Fuel Supply

1. Visually check the fuel tank for fuel. The fuel gauge may be faulty.
2. Ensure that the fuel supply valve (if equipped) is in the full OPEN position.
3. If the temperature is below 0 °C (32 °F), check for solidified fuel (wax).
4. Check the primary filter/water separator for water in the fuel.
5. Check for fuel supply lines that are restricted.
6. Check that the low-pressure fuel lines are tight and secured properly.
7. Check the fuel filters.
8. Check the diesel fuel for contamination.
9. Check for air in the fuel system.
10. Ensure that the fuel system has been primed.
11. Check the fuel pressure.
12. If the repair does not eliminate the fault refer to "Fuel Rail Pump".

Fuel Rail Pump

Note: The fuel rail pump that is installed by the factory is a non-serviceable item. If any mechanical fault or any electrical fault occurs within the fuel rail pump then the fuel rail pump must be replaced.

1. Use the electronic service tool to select the correct screen display. Refer to Troubleshooting, "Troubleshooting with a Diagnostic Code".
2. If the fault is not eliminated, refer to "Low Compression (Cylinder Pressure)".

Low Compression (Cylinder Pressure)

1. Perform a compression test.
2. If low compression is noted on any cylinders, investigate the cause and rectify the cause.

Possible causes of low compression are shown in the following list:

- Loose glow plugs
- Faulty piston
- Faulty piston rings
- Worn cylinder bores
- Worn valves
- Faulty cylinder head gasket
- Damaged cylinder head

3. Perform all necessary repairs.
4. Ensure that the repairs have eliminated the faults.
5. If the repair does not eliminate the fault refer to "Individual Malfunctioning Cylinders".

Individual Malfunctioning Cylinders

1. With the engine speed at a fast idle, use the electronic service tool to isolate one cylinder at a time. Note if there is any reduction in engine speed. If a reduction in engine speed is not noted, the isolated cylinder is not operating under normal conditions. If the isolation of a particular cylinder results in a reduction of engine speed that is less than normal. The reduction in engine speed may indicate that the cylinder is operating below normal performance. Investigate the cause of the fault on any cylinder that is not operating. Investigate the cause of the fault on any cylinder that is operating below normal performance.
2. Rectify any faults.
3. If all cylinders have been checked and no there was no problems with the cylinders, proceed to "Electronic Unit Injectors".

Electronic Unit Injectors

1. With the engine speed at a fast idle, use the electronic service tool to isolate one cylinder at a time. Note if there is any reduction in engine speed. If a reduction in engine speed is not noted, the isolated electronic unit injector is not operating under normal conditions. If the isolation of a particular cylinder results in a reduction of engine speed that is less than normal, this may indicate that the electronic unit injector is operating below normal performance.
2. Remove the electronic unit injector from the suspect cylinder.
3. Install a new electronic unit injector.
4. Repeat the test in 1. If the fault is still apparent, remove the replacement electronic unit injector and install the original electronic unit injector.
5. If the fault is not eliminated, check for active diagnostic fault codes.

i04010453

Engine Oil in Cooling System

Note: This is not an electronic system fault.

Probable Causes

- Engine oil cooler
- Cylinder head gasket
- Cylinder head
- Cylinder block

Recommended Actions

Engine Oil Cooler

1. Drain the coolant from the engine and the radiator. Drain the lubricating oil from the engine oil cooler.
2. Check for leaks in the oil cooler assembly. If a leak is found, install a new oil cooler.

Cylinder Head Gasket

1. Remove the cylinder head.
2. Inspect the cylinder head gasket for faults and any signs of leakage.
3. If necessary, install a new cylinder head gasket.

4. If there was no obvious signs of a faulty head gasket proceed to "Cylinder Head".

Cylinder Head

1. Check the cylinder head for flatness.
2. Check the mating face of the cylinder head for faults and signs of leakage. If a fault is found, replace the cylinder head. If signs of leakage are found, determine the cause of the leakage.
3. If the cylinder head is flat and if the cylinder head does not have any faults, refer to "Cylinder Block".

Cylinder Block

Inspect the top face of the cylinder block for faults and signs of leakage. If a fault is found, replace the cylinder block. If signs of leakage are found, determine the cause of the leakage.

Assembly after Repair

1. Install the cylinder head.
2. Replenish the engine with clean engine oil to the correct level.
3. Fill the cooling system.

i04012450

Engine Speed Does Not Change

Note: Use this procedure only if the engine speed does not change. This fault will not occur in a generator set application.

Probable Causes

- Diagnostic codes
- Throttle position sensor

Recommended Repairs

Diagnostic Codes

Check for active diagnostic codes on the electronic service tool. Troubleshoot any active codes before continuing with this procedure.

Use the electronic service tool to check the setup of the throttle.

Throttle Position Sensor

Refer to Troubleshooting, "Analog Throttle Position Sensor Circuit - Test" or Troubleshooting, "Digital Throttle Position Sensor Circuit - Test" if any of the following diagnostic codes are active:

- 0091-08 Throttle Position Sensor abnormal frequency, pulse width or period
- 0774-08 Sec Throttle Position Sensor abnormal frequency, pulse width or period

i04010455

Engine Stalls at Low RPM

Probable Causes

- Diagnostic codes
- Accessory equipment
- Fuel supply
- Electronic unit injectors

Recommended Actions

Diagnostic Codes

Check for active diagnostic codes on the electronic service tool. Troubleshoot any active codes before continuing with this procedure.

Accessory Equipment

Check all accessory equipment for faults that may create excessive load on the engine. Repair any damaged components or replace any damaged components.

Fuel Supply

1. Visually check the fuel tank for fuel. The fuel gauge may be faulty.
2. Ensure that the fuel supply valve (if equipped) is in the full OPEN position.
3. If the temperature is below 0 °C (32 °F), check for solidified fuel (wax).
4. Check the primary filter/water separator for water in the fuel.
5. Check for fuel supply lines that are restricted.

6. Check that the low-pressure fuel lines are tight and correctly secured.
7. Check the fuel filters.
8. Check the diesel fuel for contamination.
9. Check for air in the fuel system.
10. Ensure that the fuel system has been primed.
11. Check the fuel pressure.
12. If necessary, repair any faults.
13. If there are no apparent faults, refer to "Electronic Unit Injectors".

Electronic Unit Injectors

1. With the engine speed at a fast idle, use the electronic service tool to isolate one cylinder at a time. Note if there is any reduction in engine speed. If a reduction in engine speed is not noted, the isolated electronic unit injector is not operating under normal conditions. If the isolation of a particular cylinder results in a reduction of engine speed that is less than normal, this may indicate that the electronic unit injector is operating below normal performance.
2. Remove the electronic unit injector from the suspect cylinder.
3. Install a new electronic unit injector.
4. Repeat the test in 1. If the fault is still apparent, remove the replacement electronic unit injector and install the original electronic unit injector.
5. If the fault is not eliminated, check for active diagnostic fault codes.

i04010458

Engine Vibration

Note: This is not an electronic system fault.

Probable Causes

- Vibration damper
- Engine supports
- Low compression (cylinder pressure)
- Individual malfunctioning cylinder
- Electronic unit injectors

Recommended Actions

Vibration Damper

Check the vibration damper for damage. Install a new vibration damper, if necessary. Inspect the mounting bolts for damage and/or for wear. Replace any damaged bolts.

Ensure that the repairs have eliminated the fault. If the vibration is still present, proceed to "Engine Supports".

Engine Supports

1. Check for any of the following conditions:

- Loose engine supports
- Loose mounting brackets or broken mounting brackets
- Loose bolts
- Omitted bolts

2. Make all necessary repairs. Ensure that the repairs have eliminated the fault. If the vibration is still present, proceed to "Low Compression (Cylinder Pressure)".

Low Compression (Cylinder Pressure)

1. Perform a compression test.
2. If low compression is noted on any cylinders, investigate the cause and rectify the fault.

Possible causes of low compression are shown in the following list:

- Loose glow plugs
- Faulty piston
- Faulty piston rings
- Worn cylinder bores
- Worn valves
- Faulty cylinder head gasket
- Damaged cylinder head

3. Perform all necessary repairs.
4. Ensure that the repairs have eliminated the fault.
5. If the repair does not eliminate the fault refer to "Malfunctioning Individual Cylinder".

Malfunctioning Individual Cylinder

1. With the engine speed at a fast idle, use the electronic service tool to isolate one cylinder at a time. Note if there is any reduction in engine speed. If a reduction in engine speed is not noted, the isolated cylinder is not operating under normal conditions. If the isolation of a particular cylinder results in a reduction of engine speed that is less than normal. The reduction in engine speed may indicate that the cylinder is operating below normal performance. Investigate the cause of the fault on any cylinder that is not operating. Investigate the cause of the fault on any cylinder that is operating below normal performance.
2. If all cylinders have been checked and there are no faults with the cylinders, proceed to "Electronic Unit Injectors".

Electronic Unit Injectors

1. With the engine speed at a fast idle, use the electronic service tool to isolate one cylinder at a time. Note if there is any reduction in engine speed. If a reduction in engine speed is not noted, the isolated electronic unit injector is not operating under normal conditions. If the isolation of a particular cylinder results in a reduction of engine speed that is less than normal, this may indicate that the electronic unit injector is operating below normal performance.
2. Remove the electronic unit injector from the suspect cylinder.
3. Install a new electronic unit injector.
4. Repeat the test in 1. If the fault is still apparent, remove the replacement electronic unit injector and install the original electronic unit injector.

i04010459

Engine Will Not Crank

Probable Causes

- Battery cables and/or batteries
- Starting motor solenoid
- Starting circuit
- Starting motor and/or flywheel ring gear
- Electrical power supply
- Internal engine fault

Recommended Repairs

Battery Cables and/or Batteries

1. Inspect the main power switch, battery posts, and battery cables for loose connections and corrosion. If the battery cables are corroded, remove the battery cables and clean the battery cables. Clean the battery posts. Replace the cables. Tighten any loose connections.
2. Inspect the batteries.
 - a. Charge the batteries.
 - b. Load test the batteries.

Starting Motor Solenoid or Starting Circuit

1. Test the operation of the starting motor solenoid.
2. Check the wiring to the starting motor solenoid.

Starting Motor and/or Flywheel Ring Gear

1. Test the operation of the starting motor. Check the wiring for the starting motor.
2. Inspect the pinion on the starting motor and the flywheel ring gear for damage.

Electrical Power Supply

Check the electrical power supply. Refer to Troubleshooting, "Electrical Power Supply Circuit - Test".

Internal Engine Fault

1. Remove the glow plugs.
2. Attempt to rotate the crankshaft through 360 degrees in both directions. If the crankshaft rotates correctly but fluid is expelled from the hole for the glow plug, investigate the cause of the fluid in the cylinder.
3. If the crankshaft does not rotate through 360 degrees in both directions, perform the following procedure:
 - a. Disassemble the engine.
 - b. Inspect the internal components for the following conditions:
 - Seizure
 - Broken components

- Bent components

4. If the crankshaft rotates correctly and no fluid is expelled, install the glow plugs.

i04010460

Excessive Black Smoke

Probable Causes

- Diagnostic codes
- ECM software
- Air intake system or exhaust system
- Valve lash
- Turbocharger
- Low compression (cylinder pressure)
- Electronic unit injectors
- Individual malfunctioning cylinder

Recommended Actions

Diagnostic Codes

Check for active diagnostic codes on the electronic service tool. Troubleshoot any active codes before continuing with this procedure.

ECM Software

1. Connect the electronic service tool to the diagnostic connector and check for the following conditions:
 - Check for the correct engine serial number
 - Check for the correct arrangement number
 - Check for the correct software
2. Use the electronic service tool to verify any active diagnostic codes.
3. If diagnostic codes are present, the Electronic Control Module (ECM) must be programmed with the correct information.
4. If the repairs have not eliminated the fault proceed to "Air Intake System or Exhaust System".

Air Intake System or Exhaust System

1. Check the air filter restriction indicator, if equipped.
2. Ensure that the air filter is clean and serviceable.
3. Check the air intake and the exhaust system for the following defects:
 - Blockages
 - Restrictions
 - Damage to the air intake and exhaust lines and hoses
4. Make all necessary repairs to the engine.
5. If the fault has not been eliminated, proceed to "Valve Lash".

Valve Lash

Ensure that the valve lash is correct. Reset the valve lash if it is not correct.

If the repair does not eliminate the fault proceed to "Turbocharger".

Turbocharger

Note: The turbocharger that is installed on this engine is a non-serviceable item. If any mechanical fault exists, then the turbocharger must be replaced.

1. Ensure that the mounting bolts for the turbocharger are tight.
2. Check that the oil drain for the turbocharger is not blocked or restricted.
3. Check that the compressor housing for the turbocharger is free of dirt, debris, and damage.
4. Check that the turbine housing for the turbocharger is free of dirt, debris, and damage.
5. Check that the turbine blades rotate freely in the turbocharger.
6. Ensure that the wastegate on the turbocharger is adjusted correctly. If the wastegate actuator is faulty, replace the turbocharger.
7. If necessary, replace the turbocharger.
8. Check that the repairs have eliminated the fault.
9. If the repairs have not eliminated the fault proceed to "Low Compression (Cylinder Pressure)".

Low Compression (Cylinder Pressure)

1. Perform a compression test.
2. If low compression is noted on any cylinders, investigate the cause and rectify the cause.

Possible causes of low compression are shown in the following list:

- Loose glow plugs
 - Faulty piston
 - Faulty piston rings
 - Worn cylinder bores
 - Worn valves
 - Faulty cylinder head gasket
 - Damaged cylinder head
3. Perform all necessary repairs.
 4. Ensure that the repairs have eliminated the fault.
 5. If the repair does not eliminate the fault refer to “Electronic Unit Injectors”.

Electronic Unit Injectors

1. With the engine speed at a fast idle, use the electronic service tool to isolate one cylinder at a time. Note if there is any reduction in engine speed. If a reduction in engine speed is not noted, the isolated electronic unit injector is not operating under normal conditions. If the isolation of a particular cylinder results in a reduction of engine speed that is less than normal. The reduction in engine speed may indicate that the electronic unit injector is operating below normal performance.
2. Remove the electronic unit injector from the suspect cylinder.
3. Install a new electronic unit injector.
4. Repeat the test in 1. If the fault is still apparent, remove the replacement electronic unit injector and install the original electronic unit injector.
5. If the fault is not eliminated, proceed to “Individual Malfunctioning Cylinder”.

Individual Malfunctioning Cylinder

1. With the engine speed at a fast idle, use the electronic service tool to isolate one cylinder at a time. Note if there is any reduction in engine speed. If a reduction in engine speed is not noted, the isolated cylinder is not operating under normal conditions. If the isolation of a particular cylinder results in a reduction of engine speed that is less than normal. The reduction in engine speed may indicate that the cylinder is operating below normal performance. Investigate the cause of the fault on any cylinder that is not operating. Investigate the cause of the fault on any cylinder that is operating below normal performance.

i04010461

Excessive Engine Oil Consumption

Probable Causes

- Misreading oil level
- Oil leaks
- Engine crankcase breather
- Oil level
- Air intake and exhaust system
- Turbocharger
- Low compression (cylinder pressure)

Recommended Actions

Misreading Oil Level

1. Accurately measure the consumption of oil and fuel over a period of 50 engine hours.
2. If the oil consumption is greater than 0.2% of the fuel consumption, use the following procedure in order to investigate the cause of the high oil consumption.

Oil Leaks

1. Check for evidence of oil leaks on the engine.
2. Rectify any oil leaks from the engine.
3. Check for evidence of oil in the coolant. Refer to Troubleshooting, “Engine Oil in Cooling System”.

4. If no oil leaks are identified, refer to “Engine Crankcase Breather”.

Engine Crankcase Breather

1. Check the engine crankcase breather for blockage or restrictions.
2. Check for excessive oil from the outlet of the breather.
3. Repair all defects. Verify that the repair has eliminated the fault.
4. If no faults are found, refer to “Oil Level”.

Oil Level

1. Check the oil level in the engine.
2. If the oil level is high, check for contamination of the oil with coolant. Refer to Troubleshooting, “Coolant in Engine Oil”.
3. If no contamination is identified, remove any excess oil.
4. If the oil level is satisfactory, refer to “Air Intake and Exhaust System”.

Air Intake and Exhaust System

1. Check the air filter restriction indicator, if equipped.
2. Ensure that the air filter is clean and serviceable.
3. Check the air intake and the exhaust system for the following defects:
 - Blockages
 - Restrictions
 - Damage to the air intake and exhaust lines and hoses
4. Make all necessary repairs to the engine.
5. Ensure that the repairs have eliminated the diagnostic code.
6. If no faults are found, refer to “Turbocharger”.

Turbocharger

Note: The turbocharger that is installed on this engine is a nonserviceable item. If any mechanical fault exists, then the turbocharger must be replaced.

1. Check that the oil drain for the turbocharger is not blocked or restricted.

2. Check the turbocharger for evidence of internal oil leaks.
3. If necessary, replace the turbocharger.
4. Check that the repairs have eliminated the faults.
5. If the repairs have not eliminated the fault proceed to “Low Compression (cylinder pressure)”.

Low Compression (cylinder pressure)

1. Perform a compression test.
2. If low compression is noted on any cylinders, investigate the cause and rectify the cause.

Possible causes of low compression are shown in the following list:

- Loose glow plugs
- Faulty piston
- Worn piston rings
- Worn cylinder bores
- Worn valves
- Faulty cylinder head gasket
- Damaged cylinder head

3. Perform all necessary repairs.
4. Ensure that the repairs have eliminated the faults.

i04010462

Excessive Fuel Consumption

Probable Causes

- Diagnostic codes
- Misreading of fuel level
- Fuel quality
- Quality of oil
- Low engine temperature
- Prolonged operation at idle speed
- Engine operating speed
- Air intake and exhaust system

- Reduced pressure of intake air
- Excessive valve lash
- Failure of the primary speed/timing sensor

Recommended Actions

Diagnostic Codes

1. Use the electronic service tool to check for any diagnostic codes that may be related to high fuel consumption.

Misreading of Fuel Level

1. Monitor the fuel consumption over a period of 50 engine hours. If the fuel consumption is excessive, perform the following procedure.

Fuel Quality

1. The quality of the fuel that is used in the engine will affect the rate of fuel consumption.
2. If the fuel is not of an acceptable quality, drain the fuel system and replace the fuel filters. Refill the fuel system with fuel of an acceptable quality.
3. If the fuel is of an acceptable quality, refer to "Quality of Oil".

Quality of Oil

1. The nominal viscosity of the lubricating oil that is used in the engine will affect the rate of fuel consumption. The viscosity of lubricating oil is defined by the SAE grade of the lubricating oil. The grade of the lubricating oil must be correct for the ambient conditions. Lubricating oil that is intended for use in high ambient temperatures will have a negative effect upon the rate of fuel consumption in cold ambient temperatures.
2. The actual viscosity of the lubricating oil that is used in the engine will change throughout the service life of the oil. Lubricating oil that is heavily contaminated will have a negative effect upon the rate of fuel consumption.
3. If the oil is not of an acceptable quality or if the oil has exceeded the service life, drain the oil system and replace the oil filters. Refill the oil system with oil of an acceptable quality.
4. If the oil is of an acceptable quality, refer to "Operation in Cold Conditions".

Low Engine Temperature

1. The operating temperature of the engine will affect the rate of fuel consumption. Operation of the engine below the correct temperature will increase fuel consumption. Failure of the water temperature regulator can prevent the engine from operating at the correct temperature.
2. If the engine operating temperature is low, check the operation of the water temperature regulator. If the water temperature regulator does not operate correctly, a new water temperature regulator must be installed.

Prolonged Operation at Idle Speed

Prolonged operation of the engine at idle speed increases fuel consumption.

When the engine is operated at idle speed, the fuel that is consumed provides no useful work. Prolonged operation at idle speed will cause a measurable deterioration in the overall fuel consumption of the engine.

Operation of the engine for long periods at idle speed will cause a deterioration of the internal components of the engine. A deterioration of the internal components of the engine will increase fuel consumption.

Engine Operating Speed

The operating speed of the engine will affect the rate of fuel consumption.

High engine speed will increase fuel consumption. At high engine speeds, internal power losses in the engine increase and more power is required to drive the alternator and the fan. These power losses increase fuel consumption.

Lugging down the engine to a low engine speed will increase fuel consumption. At low engine speeds, the combustion efficiency of the engine is reduced. This will require more fuel to be used.

Air Inlet and Exhaust System

Leakage of gas or an increased restriction in either the air intake or the exhaust system can reduce the flow of combustion gas through the engine. A change in the flow of combustion air into the engine adversely affects combustion efficiency and the rate of fuel consumption.

1. Check the air intake system for leakage or restrictions.
2. Check the exhaust system for leakage or restrictions.

3. Repair all defects. Verify that the repair has eliminated the fault.

Reduced Pressure of Intake Air

1. If the pressure of the intake air at the intake manifold is lower than normal, either the speed of the engine will need to be higher or more fuel must be injected in order to produce the same power. Either of these conditions will increase the fuel consumption.

Note: If the engine is equipped with a wastegate regulator, low pressure in the intake manifold will create a 526-07 diagnostic code.

2. Check the pipe from the outlet of the turbocharger compressor to the intake manifold for leaks. If necessary, repair any leaks.
3. Check for the correct operation of the wastegate in the turbocharger.
4. If the turbocharger or the wastegate is suspected as being faulty, replace the turbocharger.

Excessive Valve Lash

Excessive valve lash will cause a change in the timing of the opening and closing of the inlet and exhaust valves. Excessive valve lash can cause a reduction of the flow of combustion air into the engine. Reduced flow of combustion air will increase the fuel consumption rate.

Refer to the Troubleshooting Guide, "Excessive Valve Lash".

Failure of the Primary Speed/Timing Sensor

If the primary speed/timing sensor fails, the engine will continue to operate using the signal from the secondary speed/timing sensor on the fuel rail pump. The secondary speed/timing sensor is less precise than the primary speed/timing sensor. Timing differences between the secondary speed/timing sensor and the primary speed/timing sensor may cause an increase in fuel consumption.

1. Use the electronic service tool to check for active diagnostic codes that relate to the primary speed/timing sensor.
2. If necessary, replace the primary speed/timing sensor.

Excessive Valve Lash

Note: This is not an electronic system fault.

Probable Causes

- Lubrication
- Valve train components
- Valve lash

Recommended Actions

Lubrication

1. Remove the valve mechanism cover.
2. Crank the engine and check the lubrication in the valve compartment. Ensure that there is adequate engine oil flow in the valve compartment. The passages for the engine oil must be clean.

Note: Do not run the engine without the valve mechanism cover.

Valve Train Components

1. Inspect the following components of the valve train:
 - Rocker arms
 - Valve bridges
 - Pushrods
 - Valve lifters
 - Camshaft
 - Valve stems
 - Rocker shafts
2. Check the components for the following conditions: abnormal wear, excessive wear, straightness, and cleanliness. If necessary, use new parts for replacement.

Note: If the camshaft is replaced, new valve lifters must also be used.

Valve Lash

Adjust the valve lash of the engine.

i04010464

Excessive White Smoke

Note: Some white smoke may be present during cold start-up conditions when the engine is operating normally. If the white smoke persists, there may be a fault.

Probable Causes

- Coolant temperature sensor circuit
- Low coolant temperature
- Glow plugs
- Fuel quality
- Valve lash
- Low compression (cylinder pressure)
- Individual malfunctioning cylinder

Recommended Actions

Coolant Temperature Sensor Circuit

1. Connect the electronic service tool to the diagnostic connector.
2. Monitor the display screen on the electronic service tool in order to verify the presence of active diagnostic codes for the coolant temperature. Refer to Troubleshooting, "Engine Temperature Sensor Open or Short Circuit - Test".
3. If the fault has not been eliminated, proceed to "Low Coolant Temperature".

Low Coolant Temperature

Check that the water temperature regulator is operating correctly.

If the water temperature regulator is operating correctly, refer to "Glow Plugs".

Glow Plugs

1. Check for proper operation of the glow plugs.
2. If the repairs do not eliminate the fault refer to "Fuel Quality".

Fuel Quality

1. Check the diesel fuel for quality.

Note: Diesel fuel with a low cetane value is likely to cause white smoke.

2. If the repair does not eliminate the fault refer to "Valve Lash".

Valve Lash

1. Ensure that the valve lash is correct.
2. If the repair does not eliminate the fault proceed to "Low Compression (cylinder pressure)".

Low Compression (cylinder pressure)

1. Perform a compression test.
2. If low compression is noted on any cylinders, investigate the cause and rectify the cause.

Possible causes of low compression are shown in the following list:

- Loose glow plugs
 - Faulty piston
 - Faulty piston rings
 - Worn cylinder bores
 - Worn valves
 - Faulty cylinder head gasket
 - Damaged cylinder head
3. Perform all necessary repairs.
 4. Ensure that the repairs have eliminated the faults.
 5. If the repair does not eliminate the fault refer to "Individual Malfunctioning Cylinder".

Individual Malfunctioning Cylinder

1. With the engine speed at a fast idle, use the electronic service tool to isolate one cylinder at a time. Note if there is any reduction in engine speed. If a reduction in engine speed is not noted, the isolated cylinder is not operating under normal conditions. If the isolation of a particular cylinder results in a reduction of engine speed that is less than normal. The reduction in engine speed may indicate that the cylinder is operating below normal performance. Investigate the cause of the fault on any cylinder that is not operating. Investigate the cause of the fault on any cylinder that is operating below normal performance.
2. Rectify any faults.

i04010465

Exhaust Temperature Is High

Probable Causes

- Diagnostic codes
- Electrical connectors
- Air inlet and exhaust system

Recommended Actions

Diagnostic Codes

Connect the electronic service tool and check for active diagnostic codes. Troubleshoot any active diagnostic codes before continuing with this procedure.

Electrical Connectors

Check for correct installation of the J2/P2/A-C1 Electronic Control Module (ECM) connector and of the A-C10, A-C11, and A-C12 connectors that are for the injectors. Refer to the diagnostic functional test Troubleshooting, "Electrical Connectors - Inspect".

Air Inlet and Exhaust System

1. Check the air inlet manifold pressure. Check for air inlet restrictions and/or leaks.
2. Check for leaks between the exhaust manifold and the turbocharger. Check for exhaust restrictions.

i02119587

Fuel Dilution of Engine Oil

Probable Causes

- Leaking seals on the case of the unit injector or on the barrel of the unit injector
- Leaking seals on the fuel line adapter for the cylinder head
- Excessive leakage from the unit injector tip or breakage of the unit injector tip
- Cracked fuel supply manifold
- Leaking seal on the fuel transfer pump

Recommended Actions

Leaking Seals on the Case of the Unit Injector or on the Barrel of the Unit Injector

Look for signs of damage to the seals for the unit injectors. Replace any seals that are leaking.

Leaking Seals on the Fuel Line Adapter for the Cylinder Head

Look for signs of damage to the seals on the fuel line adapter for the cylinder head. Repair any leaking fuel lines or components and/or replace any leaking fuel lines or components.

Excessive Leakage from the Unit Injector Tip or Breakage of the Unit Injector Tip

Look for signs of damage to the unit injectors. If necessary, repair the unit injectors or replace the unit injectors.

Cracked Fuel Supply Manifold

Look for signs of damage to the fuel supply manifold.

Leaking Fuel Transfer Pump Seal

Ensure that the weep hole is not plugged. If necessary, repair the fuel transfer pump or replace the fuel transfer pump.

i04010466

Intermittent Engine Shutdown

Note: Use this procedure only if the engine shuts down completely and the engine must be restarted.

Probable Causes

- Diagnostic codes
- Air Intake
- Electrical connectors
- Fuel supply
- Engine shutdown switch (if applicable)

Recommended Actions

Diagnostic Codes

Check for any event and active diagnostic codes on the electronic service tool. Troubleshoot any active codes or recently logged diagnostic codes before continuing with this procedure.

Air Intake

1. Check the air filter for blockage or restriction.
2. Check the air intake duct for blockages or restrictions.

Electrical Connectors

1. Check for correct installation of ECM connectors at the following locations:
 - P1/E-C1 ECM connector
 - P2/A-C1 ECM connector
 - A-C2 Fuel rail pump solenoid connector
2. Refer to Troubleshooting, "Electrical Connectors - Inspect".
3. Inspect the battery wires from the ECM to the battery compartment. Refer to the Schematic Diagram. Inspect the wires and the power relay. Check the power and ground connections to the ECM. Refer to the schematic diagram for more information.
4. Select the "Wiggle Test" from the diagnostic tests on the electronic service tool.
5. Choose the appropriate group of parameters to monitor.
6. Press the "Start" button. Wiggle the wiring harness in order to reproduce intermittent faults.

Note: If an intermittent fault exists, the status will be highlighted and an audible beep will be heard.

7. Repair any faults and ensure that the symptom has been cleared. If the fault is still present, refer to "Fuel Supply".

Fuel Supply

NOTICE

Do not crank the engine continuously for more than 30 seconds. Allow the starting motor to cool for two minutes before cranking the engine again.

1. Visually check the fuel tank for fuel. The fuel gauge may be faulty.
2. Ensure that the fuel supply valve (if equipped) is in the full OPEN position.
3. If the temperature is below 0 °C (32 °F), check for solidified fuel (wax).
4. Check the primary filter/water separator for water in the fuel.
5. Check for fuel supply lines that are restricted.
6. Check that the low-pressure fuel lines are tight and secured properly.
7. Check the fuel filters.
8. Check the diesel fuel for contamination.
9. Check for air in the fuel system.
10. Ensure that the fuel system has been primed.
11. Check the fuel pressure.

Engine Shutdown Switch (If Applicable)

Use the electronic service tool to monitor the status of the engine shutdown switches. Check for status indicators that are active due to the engine shutdown switch. Determine the cause for the shutdown and make any repairs necessary.

i04010467

Intermittent Low Power or Power Cutout

Note: Use this procedure only if the engine does not shut down completely.

Probable Causes

- Diagnostic codes
- Electrical connectors
- ECM connection
- Fuel supply
- Intake manifold pressure
- Throttle signal
- Power supply to the Electronic Control Module (ECM)

Recommended Actions

NOTICE

Do not crank the engine continuously for more than 30 seconds. Allow the starting motor to cool for two minutes before cranking the engine again.

Diagnostic Codes

Check for active diagnostic codes and event codes on the electronic service tool. Troubleshoot any active codes before continuing with this procedure.

Electrical Connectors

1. Inspect the electrical connectors. Refer to Troubleshooting, "Electrical Connectors - Inspect".
2. Repair any faulty electrical connectors or replace any faulty electrical connectors.
3. Ensure that all the connector seals are in place and that the connectors have been correctly installed.
4. Ensure that the repairs have eliminated the fault. If the fault has not been eliminated proceed to "ECM Connection".

ECM Connection

1. If a fault is suspected with the ECM power and ground connections refer to Troubleshooting, "Electrical Power Supply Circuit - Test".
2. Verify that the ECM connections for the power and ground connections at the fuel pump are correctly connected.
3. Repair any faults and ensure that the faults have been eliminated.
4. If the repairs do not eliminate the faults, proceed to "Fuel Supply".

Fuel Supply

1. Visually check the fuel tank for fuel. The fuel gauge may be faulty.
2. Ensure that the fuel supply valve (if equipped) is in the full OPEN position.
3. If the temperature is below 0 °C (32 °F), check for solidified fuel (wax).
4. Check the primary filter/water separator for water in the fuel.
5. Check for fuel supply lines that are restricted.

6. Check that the low pressure fuel lines are tight and secured properly.
7. Check the fuel filters.
8. Check the diesel fuel for contamination.
9. Check for air in the fuel system.
10. Ensure that the fuel system has been primed.
11. Check the fuel pressure. Start the engine and then use the electronic service tool to check that the pressure in the fuel rail is more than 18000 kPa (2610 psi).
12. If the repair does not eliminate the fault refer to "Intake Manifold Pressure".

Intake Manifold Pressure

1. Use the electronic service tool to verify the intake manifold pressure.
2. Turn the start switch to the ON position.
3. The intake manifold pressure should read 0 ± 0.5 kPa (0 ± 0.07 psi). If the intake manifold pressure is not within the limits, perform the following steps.
4. Ensure that the air filter is clean and serviceable.
5. Check the air intake and the exhaust system for the following defects:
 - Blockages
 - Restrictions
 - Damage to the air intake and exhaust lines and hoses

Throttle Signal

Monitor the status for "Throttle Position" on the electronic service tool. Verify that the status for "Throttle Position" is stable and that the engine is able to reach high idle speed.

ECM Power Supply

1. Inspect the circuit between the ECM and the batteries for poor connections and damage. Inspect the wiring, the connectors, and the power relay.
2. Inspect the circuit between the ECM and the keyswitch. Inspect the wires, the connectors, and the keyswitch.

i04010468

Low Engine Oil Pressure

NOTICE

Do not operate the engine with low oil pressure. Engine damage will result. If measured oil pressure is low, discontinue engine operation until the problem is corrected.

Probable Causes

- Engine oil level
- Oil specification
- Engine oil pressure gauge (if equipped)
- Engine oil filter
- Engine oil cooler
- Piston cooling jets
- Engine oil suction tube
- Engine oil pump
- Bearing clearance
- Engine wear

Recommended Actions

Engine Oil Level

1. Check the engine oil level. If necessary, add oil.
2. If the fault is still apparent, proceed to “Oil Specification”.

Oil Specification

1. Make sure that engine oil of the correct specification is used.
2. If necessary, drain the oil system and refill the oil system with engine oil of the correct specification.
3. If the fault is still apparent, proceed to “Engine Oil Pressure Gauge”.

Engine Oil Pressure Gauge (if equipped)

1. Certain applications may have an engine oil pressure gauge installed or can monitor the engine oil pressure from an electronic display. Check the actual engine oil pressure with a calibrated test gauge. Install the oil pressure gauge at a suitable test point on the engine. Compare the oil pressure reading from the electronic service tool to the pressure on the test gauge.
2. If no difference is noted between the indicated oil pressures, proceed to “Engine Oil Filter”.
3. If a difference is noted between the indicated oil pressures, proceed to “Engine Oil Cooler”.

Engine Oil Filter

1. Remove the engine oil filter.
2. Inspect the engine oil filter for evidence of blockage.
3. Install a new engine oil filter.
4. If the fault is still apparent, proceed to “Engine Oil Cooler”.

Engine Oil Cooler

1. If oil flow or coolant flow through the oil cooler is suspected of being low, replace the oil cooler.
2. If the fault is still apparent, proceed to “Piston Cooling Jets”.

Piston Cooling Jets

1. Inspect the piston cooling jets for damage. Replace any piston cooling jet that appears to be cracked, broken, or missing.
2. If no damage is found, proceed to “Engine Oil Suction Tube”.

Engine Oil Suction Tube

1. Check the inlet screen on the oil suction tube and remove any material that may be restricting oil flow.
2. Check the joints of the oil suction tube for cracks or a damaged joint that may allow air leakage into the supply to the oil pump.
3. If no faults are found, proceed to “Engine Oil Pump”.

Engine Oil Pump

1. Inspect the components of the engine oil pump for excessive wear. Repair the oil pump or replace the oil pump, if necessary.
2. If no faults are found, proceed to "Bearing Clearance".

Bearing Clearance

Inspect the engine components for excessive bearing clearance or damaged bearings. If necessary, replace the bearings and/or the components. Inspect the following components for excessive bearing clearance:

- Crankshaft main bearings
- Connecting rod bearings
- Camshaft front bearing
- Idler gear bearing

i04010470

Low Power/Poor or No Response to Throttle

Probable Causes

- Diagnostic codes
- Event codes
- Electrical connectors
- Air intake and exhaust system
- Valve lash
- Turbocharger
- Fuel supply
- Low compression (cylinder pressure)
- Individual malfunctioning cylinder
- Electronic unit injectors
- Throttle signal
- Mechanical throttle cable

Recommended Actions

NOTICE

Do not crank the engine continuously for more than 30 seconds. Allow the starting motor to cool for two minutes before cranking the engine again.

Diagnostic Codes and Event Codes

Check for active diagnostic codes on the electronic service tool. Troubleshoot any active codes before continuing with this procedure.

ECM Parameters

1. Use the electronic service tool to make sure that the FLS and FTS parameters have been correctly entered.
2. Use the electronic service tool to ensure that the correct mode was selected.
3. Use the electronic service tool to verify that the correct engine rating has been provided.
4. Use the electronic service tool to verify the maximum engine speed limit.
5. Ensure that the repairs have eliminated the fault.
6. If the repairs have not eliminated the fault proceed to "Electrical Connectors".

Electrical Connectors

1. Turn the keyswitch to the ON position.
2. Use the electronic service tool to verify that the intake manifold pressure is 0 ± 0.5 kPa (00 ± 0.070 psi). Check the 5 V sensor supply for the intake manifold pressure. Refer to Troubleshooting, "5 V Engine Pressure Sensor Supply Circuit - Test".
3. Use the electronic service tool to verify the throttle position status.
4. Run the engine until the speed is equal to the maximum no-load speed.
5. Use the electronic service tool to make sure that the throttle is set to reach the maximum no-load speed.
6. If the engine speed is erratic refer to Troubleshooting, "Throttle Position Sensor - Test".
7. If the fault has not been eliminated, proceed to "Air Intake and Exhaust System".

Throttle Signal

Monitor the status for “Throttle Position” on the electronic service tool. Verify that the status for “Throttle Position” is stable and that the engine is able to reach high idle speed.

Air Intake and Exhaust System

1. Check the air filter restriction indicator, if equipped.
2. Ensure that the air filter is clean and serviceable.
3. Check the air intake and the exhaust system for the following defects:
 - Blockages
 - Restrictions
 - Damage to the air intake and exhaust lines and hoses
4. Make all necessary repairs to the engine.
5. If the fault has not been eliminated, proceed to “Valve Lash”.

Valve Lash

1. Check the valve lash and reset the valve lash, if necessary.
2. If the repair does not eliminate the fault proceed to “Turbocharger”.

Turbocharger

Note: The turbocharger that is installed on this engine is a nonserviceable item. If any mechanical fault exists, then the turbocharger must be replaced.

1. Ensure that the mounting bolts for the turbocharger are tight.
2. Check that the oil drain for the turbocharger is not blocked or restricted.
3. Check that the compressor housing for the turbocharger is free of dirt and debris.
4. Check that the turbine housing for the turbocharger is free of dirt and debris.
5. Check that the turbine blades rotate freely in the turbocharger.
6. Ensure that the wastegate on the turbocharger is adjusted correctly. If the wastegate actuator or the turbocharger is faulty, replace the turbocharger.
7. Check that the repairs have eliminated the faults.

8. If the fault has not been eliminated, proceed to “Fuel Supply”.

Fuel Supply

1. Visually check the fuel tank for fuel. The fuel gauge may be faulty.
2. Ensure that the fuel supply valve (if equipped) is in the full OPEN position.
3. If the temperature is below 0 °C (32 °F), check for solidified fuel (wax).
4. Check the primary filter/water separator for water in the fuel.
5. Check for fuel supply lines that are restricted.
6. Check that the low-pressure fuel lines are tight and secured properly.
7. Check the fuel filters.
8. Check the diesel fuel for contamination.
9. Check for air in the fuel system.
10. Ensure that the fuel system has been primed.
11. Check the fuel pressure.
12. If the repair does not eliminate the fault refer to “Low Compression (Cylinder Pressure)”.

Low Compression (Cylinder Pressure)

1. Perform a compression test.
2. If low compression is noted on any cylinders, investigate the cause and rectify any faults.

Possible causes of low compression are shown in the following list:

- Loose glow plugs
 - Faulty piston
 - Faulty piston rings
 - Worn cylinder bores
 - Worn valves
 - Faulty cylinder head gasket
 - Damaged cylinder head
3. Perform all necessary repairs.
 4. Ensure that the repairs have eliminated the faults.

5. If the repair does not eliminate the fault refer to "Individual Malfunctioning Cylinders".

Individual Malfunctioning Cylinders

1. Use the electronic service tool to perform the "Cylinder Cut-out Test". Note if there is any reduction in engine speed. If a reduction in engine speed is not noted, the isolated cylinder is not operating under normal conditions. If the isolation of a particular cylinder results in a reduction of engine speed that is less than normal, this may indicate that the cylinder is operating below normal performance. Investigate the cause of the fault on any cylinder that is not operating. Investigate the cause of the fault on any cylinder that is operating below normal performance.
2. If all cylinders have been checked and no faults were detected, proceed to "Electronic Unit Injectors".

Electronic Unit Injectors

1. Use the electronic service tool to perform the "Cylinder Cut-out Test". Note if there is any reduction in engine speed. If a reduction in engine speed is not noted, the isolated electronic unit injector is not operating under normal conditions. If the isolation of a particular cylinder results in a reduction of engine speed that is less than normal, this may indicate that the electronic unit injector is operating below normal performance.
2. Remove the electronic unit injector from the suspect cylinder.
3. Install a new electronic unit injector.
4. Repeat the test in 1. If the fault is still apparent, remove the replacement electronic unit injector and install the original electronic unit injector.
5. If the fault is not eliminated, repeat this test procedure from Step 1.

i02529009

Mechanical Noise (Knock) in Engine

Probable Causes

- Accessory equipment
- Valve train components
- Pistons

- Connecting rod and main bearings

Recommended Actions

Accessory Equipment

1. Isolate the source of the noise. Remove the suspect engine accessory. Inspect the suspect engine accessory. Repair the engine accessory and/or replace the engine accessory if any defects are found.
2. If the mechanical noise is still apparent, refer to "Valve Train Components".

Valve Train Components

1. Remove the valve mechanism cover. Check the following items for damage: camshaft, valve springs, lifters, pushrods, and bridges. Thoroughly clean the valve train components. If the camshaft is being replaced, also replace the valve lifters. Ensure that all of the valves move freely. Replace any damaged parts.
2. If the mechanical noise is still apparent, refer to "Pistons".

Pistons

1. Inspect the pistons for damage and wear. Replace any damaged parts.
2. If the mechanical noise is still apparent, refer to "Connecting Rod and Main Bearings".

Connecting Rod and Main Bearings

Inspect the connecting rod and main bearings. Also, inspect the bearing surfaces (journals) on the crankshaft. Replace any damaged parts.

i04010489

Noise Coming from Cylinder

Probable Causes

- Fuel quality
- Valve lash
- Electronic unit injectors
- Pistons

Recommended Actions

i04010491

Fuel Quality

1. Check the fuel quality.
2. If unsatisfactory fuel is found, perform the following procedure.
 - a. Drain the fuel system.
 - b. Replace the fuel filters.
 - c. Fill the fuel system with the correct type of fuel.
 - d. Prime the fuel system.
3. If the fault is not eliminated, proceed to "Valve Lash".

Valve Lash

1. Refer to Troubleshooting, "Excessive Valve Lash".
2. If the fault has not been eliminated, proceed to "Electronic Unit Injectors".

Electronic Unit Injectors

1. With the engine speed at a fast idle, use the electronic service tool to isolate one cylinder at a time. Note if there is any reduction in engine speed. If a reduction in engine speed is not noted, the isolated electronic unit injector is not operating under normal conditions. If the isolation of a particular cylinder results in a reduction of engine speed that is less than normal, this may indicate that the electronic unit injector is operating below normal performance.
2. Remove the electronic unit injector from the suspect cylinder.
3. Install a new electronic unit injector.
4. Repeat the test in 1. If the noise is still apparent, remove the replacement electronic unit injector and install the original electronic unit injector.
5. If the fault has not been eliminated, proceed to "Pistons".

Pistons

1. Inspect the pistons for damage and wear. Replace any damaged parts.

Poor Acceleration or Response

Probable Causes

- Diagnostic codes and event codes
- Flash file
- Throttle signal
- Fuel rail pressure
- Electrical connectors
- Electronic unit injectors
- Intake manifold (boost) pressure sensor
- Air inlet and exhaust system
- Fuel supply

Recommended Actions

Note: If the problem only occurs under certain conditions, test the engine under those conditions. Examples of certain conditions are high engine idle, full load, or a specific operating temperature. Troubleshooting the symptoms under other conditions may give misleading results.

Diagnostic Codes and Event Codes

Certain diagnostic codes and/or event codes may cause poor performance. Connect the electronic service tool and check for active codes and/or logged codes. Troubleshoot any codes that are present before continuing with this procedure.

Note: Although a sensor's signal may be in the operational range of the sensor, certain failure modes of a sensor may produce an output signal that does not represent an accurate measurement. Use the electronic service tool to check that the pressures and the temperatures are fluctuating normally. Also check that the values are reasonable for the conditions that are present.

Flash File

Verify that the latest flash file has been installed into the Electronic Control Module (ECM).

Throttle Signal

Monitor the status for “Throttle Position” on the electronic service tool. Verify that the status for “Throttle Position” is stable and that the engine is able to reach high idle speed. Refer to the appropriate diagnostic functional test for your application:

- Troubleshooting, “Throttle Position Sensor - Test”
- Troubleshooting, “Speed Control (PWM) - Test”

Fuel Rail Pressure

1. If service has recently been performed on the engine, air may be present in the fuel system. Check for air in the fuel system.
2. Check the pressure in the fuel system.

Electrical Connectors

Disconnect the J1/P1/E-C1 and J2/P2/A-C1 ECM connectors. Inspect each connector for moisture and corrosion. Also, inspect the harness and connectors for the unit injectors from the ECM to the valve cover. Refer to the diagnostic functional test Troubleshooting, “Electrical Connectors - Inspect”.

Electronic Unit Injectors

1. Use the electronic service tool to perform the injector solenoid test in order to determine if all of the injector solenoids are being energized by the ECM.
2. Perform the cylinder cutout test on the electronic service tool in order to check the performance of each cylinder. Refer to the diagnostic functional test Troubleshooting, “Injector Solenoids Circuit - Test”.

Intake Manifold (Boost) Pressure Sensor

1. Monitor the status of “Intake Manifold (Boost) Pressure” for normal operation on electronic service tool. When the engine is not running, “Intake Manifold (Boost) Pressure” should be 0 kPa (0 psi).

Air Inlet and Exhaust System

1. Check the air filter restriction indicator for a plugged filter. If necessary, service the engine.
2. Check the air inlet and exhaust system for restrictions and/or leaks.

Fuel Supply

1. Visually check the fuel level in the fuel tank. Do not rely on the fuel gauge only. If necessary, add fuel to the fuel tank. If the engine has been run out of fuel, it will be necessary to prime the fuel system.
2. Check the fuel lines for the following problems: restrictions, collapsed lines, and pinched lines. If problems are found with the fuel lines, repair the lines and/or replace the lines.
3. Check the fuel tank for debris or foreign objects which may block the fuel supply.

NOTICE

Do not crank the engine continuously for more than 30 seconds. Allow the starting motor to cool for two minutes before cranking the engine again.

4. Prime the fuel system if any of the following procedures have been performed:
 - Replacement of the fuel filters
 - Service on the low-pressure fuel supply circuit
 - Replacement of unit injectors
- Note:** A sight glass in the low-pressure supply line is helpful in diagnosing air in the fuel.
5. Check fuel quality. Cold weather adversely affects the characteristics of the fuel.
 6. Check the filtered fuel pressure while the engine is being cranked. If the fuel pressure is low, replace the fuel filters. If the fuel pressure is still low, check the following items: fuel transfer pump and fuel pressure relief valve.

i04012482

Transmission Oil Pressure Is High

Probable Causes

Relief valve failure

Recommended Actions

Relief Valve Failure

1. Locate the relief valve for the transmission oil.
2. Remove any blockages and check the operation of the relief valve.

3. Repair the relief valve or replace the relief valve. Refer to the service literature from the Original Equipment Manufacturer (OEM) for additional information on the transmission for the vessel.

i04012484

Transmission Oil Temperature Is High

Probable Causes

- Oil is leaking from the transmission.
- Excessive oil in the transmission
- Transmission oil cooler (if equipped)

Recommended Actions

Oil Leaks

Locate all oil leaks and repair the leaks.

Excessive Oil in the Transmission

1. Remove excess oil. Locate the source of the extra oil and make the necessary repairs.
2. Check for restrictions in the relief valve and make the necessary repairs.
3. Check for high coolant temperature. Refer to troubleshooting without a diagnostic code Troubleshooting, "Coolant Temperature is Too High".
4. Refer to the service literature from the Original Equipment Manufacturer (OEM) for additional information on the transmission for the vessel, if necessary.

Troubleshooting with a Diagnostic Code

Flash Codes

i04015352

Flash codes are a simple way to alert the operator that a problem exists with the control system of the engine. Flash codes are a simple way to alert the operator that a problem exists with the operation of the engine. Each flash code is a three-digit number. The diagnostic lamp flashes in order to identify the flash code.

EXAMPLE

Note: Flash Code 271 would flash on the diagnostic lamp in the following manner:

- Two short flashes
- Hesitation
- Seven short flashes
- Hesitation
- One short flash

For the descriptions of the flash codes, refer to Troubleshooting, "Diagnostic Code Cross Reference".

i04010509

Diagnostic Codes

Diagnostic Codes

Diagnostic codes alert the operator that a problem in the electronic system has been detected. Diagnostic codes are also used by the service technician to identify the nature of the problem. The electronic service tool is a software program that is designed to run on a personal computer. The software can be used by the service technician in order to view the diagnostic code information for an ECM. Diagnostic codes may consist of the component identifier (CID), and the failure mode identifier (FMI).

Component Identifier (CID) – The CID indicates the component that generated the code. For example, the CID number 1 identifies the fuel injector for the number one cylinder.

Failure Mode Identifier (FMI) – The FMI indicates the type of failure.

Suspect Parameter Number (SPN) – The SPN is a code which is assigned to each component in order to identify data via the data link to the ECM. This is used on the diagnostics for the CAN data link.

Refer to Troubleshooting, "Diagnostic Code Cross Reference" for the complete list of the diagnostic codes and a description of each code. There is a troubleshooting procedure for every diagnostic code. Refer to Troubleshooting, "Troubleshooting With A Diagnostic Code".

When a diagnostic code is activated, the Electronic Control Module (ECM) transmits information about the code over the J1939 data link. The J1939 devices display the code. However, the code will be displayed with a SPN-FMI code. Refer to Troubleshooting, "Diagnostic Code Cross Reference" for a cross-reference between SPN-FMI codes and diagnostic codes.

Do not confuse diagnostic codes with event codes. Event codes alert the operator that an abnormal operating condition such as low oil pressure or high coolant temperature has been detected. Refer to Troubleshooting, "Troubleshooting with an Event Code" for additional information on event codes.

Illustration 14 is an example of the operating range of a sensor.

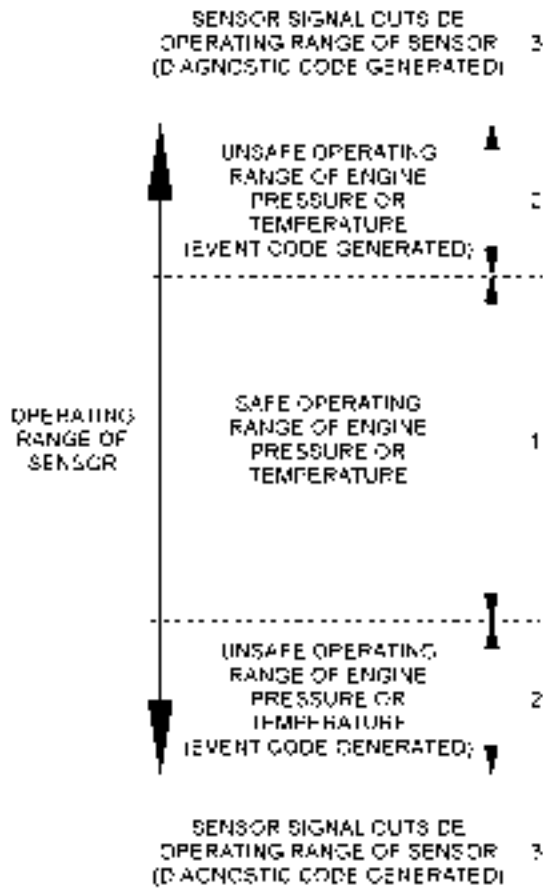

Illustration 14

g01365757

Example of the typical operating range of a sensor

- (1) This area represents the normal operating range of the engine parameter.
- (2) In these areas, the engine is operating in an unsafe operating range of the monitored parameter. An event code will be generated for the monitored parameter. The sensor circuit does not have an electronic problem. Refer to Troubleshooting, "Troubleshooting with an Event Code" for additional information on event codes.
- (3) In these areas, the signal from the sensor is outside of the operating range of the sensor. The sensor circuit has an electronic problem. A diagnostic code will be generated for the sensor circuit.

Active Diagnostic Codes

An active diagnostic code represents a problem with the electronic control system. **Correct the problem as soon as possible.**

When the ECM generates an active diagnostic code and the diagnostic lamp is activated in order to alert the operator. If the condition that generated the code is momentary, the message disappears from the list of active diagnostic codes. The diagnostic code becomes logged.

Logged Diagnostic Codes

When the ECM generates a diagnostic code, the ECM logs the code in permanent memory. The ECM has an internal diagnostic clock. Each ECM will record the following information when a code is generated:

- The hour of the first occurrence of the code
- The hour of the last occurrence of the code
- The number of occurrences of the code

This information is a valuable indicator for troubleshooting intermittent problems.

A code is cleared from memory when one of the following conditions occur:

- The service technician manually clears the code.
- The code does not recur for 100 hours.
- A new code is logged and there are already ten codes in memory. In this case, the oldest code is cleared.

Some diagnostic codes may be easily triggered. Some diagnostic codes may log occurrences that did not result in complaints. The most likely cause of an intermittent problem is a faulty connection or damaged wiring. The next likely cause is a component failure. The least likely cause is the failure of an electronic module. Diagnostic codes that are logged repeatedly may indicate a problem that needs special investigation.

Note: Always clear logged diagnostic codes after investigating and correcting the problem which generated the code.

i04010594

Diagnostic Code Cross Reference

Table 20

CDL Code	Description	3rd Party Device J1939 Code	Flash Code	
N/A	No Diagnostic Code Detected	N/A	551	
0001-02	Cylinder #1 Injector erratic, intermittent, or incorrect	651-2	111	
0001-05	Cylinder #1 Injector current below normal	651-5	111	
0001-06	Cylinder #1 Injector current above normal	651-6	111	
0001-07	Cylinder #1 Injector not responding properly	651-7	111	
0002-02	Cylinder #2 Injector erratic, intermittent, or incorrect	652-2	112	
0002-05	Cylinder #2 Injector current below normal	652-5	112	
0002-06	Cylinder #2 Injector current above normal	652-6	112	
0002-07	Cylinder #2 Injector not responding properly	652-7	112	
0003-02	Cylinder #3 Injector erratic, intermittent, or incorrect	653-2	113	
0003-05	Cylinder #3 Injector current below normal	653-5	113	
0003-06	Cylinder #3 Injector current above normal	653-6	113	
0003-07	Cylinder #3 Injector not responding properly	653-7	113	
0004-02	Cylinder #4 Injector erratic, intermittent, or incorrect	654-2	114	
0004-05	Cylinder #4 Injector current below normal	654-5	114	
0004-06	Cylinder #4 Injector current above normal	654-6	114	
0004-07	Cylinder #4 Injector not responding properly	654-7	114	
0005-02	Cylinder #5 Injector erratic, intermittent, or incorrect	655-2	115	
0005-05	Cylinder #5 Injector current below normal	655-5	115	
0005-06	Cylinder #5 Injector current above normal	655-6	115	
0005-07	Cylinder #5 Injector not responding properly	655-7	115	
0006-02	Cylinder #6 Injector erratic, intermittent, or incorrect	656-2	116	
0006-05	Cylinder #6 Injector current below normal	656-5	116	
0006-06	Cylinder #6 Injector current above normal	656-6	116	
0006-07	Cylinder #6 Injector not responding properly	656-7	116	
0041-03	8 Volt DC Supply voltage above normal	678-03	517	
0041-04	8 Volt DC Supply voltage below normal	678-04	517	
0091-13	Throttle Position Sensor incorrect calibration	91-13	154	
0091-08	Throttle Position Sensor abnormal frequency, pulse width, or period	91-08	154	
0094-03	Fuel Pressure open/short to +batt	94-03	164	
0094-04	Fuel Pressure short to ground	94-04	164	
0100-03	Engine Oil Pressure Sensor voltage above normal	100-03	157	
0100-04	Engine Oil Pressure Sensor voltage below normal	100-04	157	

(continued)

(Table 20, contd)

CDL Code	Description	3rd Party Device J1939 Code	Flash Code	
0100-10	Engine Oil Pressure Sensor abnormal rate of change	100-10	157	
0110-03	Engine Coolant Temperature Sensor voltage above normal	110-03	168	
0110-04	Engine Coolant Temperature Sensor voltage below normal	110-04	168	
0127-03	Transmission Oil Pressure open/short to +batt	127-03	311	
0127-04	Transmission Oil Pressure short to ground	127-04	311	
0168-00	Electrical System Voltage high	168-00	511	
0168-01	Electrical System Voltage low	168-01	511	
0168-02	Electrical System Voltage erratic, intermittent, or incorrect	168-02	511	
0172-03	Intake Manifold Air Temperature Sensor voltage above normal	105-03	133	
0172-04	Intake Manifold Air Temperature Sensor voltage below normal	105-04	133	
0174-03	Fuel Temperature open/short to +batt	174-03	165	
0174-04	Fuel Temperature short to ground	174-04	165	
0177-03	Transmission Oil Temperature open/short to +batt	177-03	312	
0177-04	Transmission Oil Temperature short to ground	177-04	312	
0190-08	Engine Speed Sensor abnormal frequency, pulse width, or period	190-08	141	
0253-02	Personality Module erratic, intermittent, or incorrect	234-02	416	
0261-11	Engine Timing Offset fault	637-11	143	
0262-03	5 Volt Sensor DC Power Supply voltage above normal	3509-03	516	
0262-04	5 Volt Sensor DC Power Supply voltage below normal	3509-04	516	
0268-02	Programmed Parameter Fault erratic, intermittent, or incorrect	1111-02	527	
0342-08	Secondary Engine Speed Sensor abnormal frequency, pulse width, or period	723-08	142	
0526-05	Turbo Wastegate Drive current below normal	1188-05	177	
0526-06	Turbo Wastegate Drive current above normal	1188-06	177	
0526-07	Turbo Wastegate Drive not responding properly	1188-07	177	
0535-03	Exhaust Gas Temperature short to ground	173-03	185	
0535-04	Exhaust Gas Temperature open/short to +batt	173-04	185	
0774-08	Secondary Throttle Position Sensor abnormal frequency, pulse width, or period	29-08	155	
0774-13	Secondary Throttle Position Sensor incorrect calibration	29-13	155	
0897-05	Glow Plug Start Aid Relay 2 current below normal	1084-05	-	
0897-06	Glow Plug Start Aid Relay 2 current above normal	1084-06	-	
1779-05	Fuel Rail #1 Pressure Valve Solenoid current below normal	-	162	
1779-06	Fuel Rail #1 Pressure Valve Solenoid current above normal	-	162	
1785-03	Intake Manifold Pressure Sensor voltage above normal	102-03	197	
1785-04	Intake Manifold Pressure Sensor voltage below normal	102-04	197	
1785-10	Intake Manifold Pressure Sensor abnormal rate of change	102-10	197	
1797-03	Fuel Rail Pressure Sensor voltage above normal	157-03	159	

(continued)

(Table 20, contd)

CDL Code	Description	3rd Party Device J1939 Code	Flash Code	
1797-04	Fuel Rail Pressure Sensor voltage below normal	157-04	159	
1834-02	Ignition Key Switch loss of signal	-	429	
2246-05	Glow Plug Start Aid Relay current below normal	626-05	199	
2246-06	Glow Plug Start Aid Relay current above normal	626-06	199	
Event Codes				
E096-1	High Fuel Pressure - Warning	94-15	164	
E113-1	High Transmission Oil Pressure - Warning	127-15	311	
E119-1	Low Fuel Level - Warning	096-17	-	
E179-1	Alternator Not Charging - Warning	3353-17	-	
E194-1	High Exhaust Temperature - Warning	173-15	185	
E198-1	Low Fuel Pressure - Warning	94-17	164	
E232-1	High Fuel/Water Separator Water Level - Warning	97-15	-	
E268-1	Unexpected Engine Shutdown - Warning	-	-	
E360-1	Low Oil Pressure - Warning	100-17	157	
E360-2	Low Oil Pressure - Derate	100-18	157	
E361-1	High Engine Coolant Temperature - Warning	110-15	168	
E361-2	High Engine Coolant Temperature - Derate	110-16	168	
E362-1	Engine Overspeed - Warning	190-15	141	
E363-1	High Fuel Temperature - Warning	174-15	165	
E396-2	High Fuel Rail Pressure - Warning	157-16	159	
E398-2	Low Fuel Rail Pressure - Warning	157-18	159	
E539-1	High Intake Manifold Air Temperature - Warning	105-15	133	
E539-2	High Intake Manifold Air Temperature - Derate	105-16	133	
E877-1	High Transmission Oil Temperature - Warning	177-15	312	
E1044-2	High Intake Manifold Air Pressure - Derate	102-16	135	
E1045-2	Low Intake Manifold Air Pressure - Derate	102-18	135	
E2143-1	Low Engine Coolant Level - Warning	111-17	169	
E2143-2	Low Engine Coolant Level - Derate	111-18	169	

i03449822

No Diagnostic Codes Detected

Conditions Which Generate This Code:

A flash code 0551 indicates that there are no detected faults in the system.

System Response:

This code will not appear on the electronic service tool. The indicator lamps will flash the diagnostic code. For more information on flash codes, refer to Troubleshooting, "Indicator Lamps".

Possible Performance Effect:

None

There are no faults that require troubleshooting.

Results:

i04053149

- OK – STOP.

CID 0001 FMI 05

i02655551

CID 0001 FMI 02

Conditions Which Generate This Code:

The Electronic Control Module (ECM) detects the following condition:

- Data from the electronic unit injector for the No. 1 cylinder is out of limits.
- Diagnostic code 0168-01 is not active.
- Diagnostic codes 0001-05 and 0001-06 are not active.
- No 0041 diagnostic codes are active.
- No 0262 diagnostic codes are active.
- Diagnostic code 0190-08 is not active.
- No 0110 diagnostic codes are active.

System Response:

If equipped, the warning light will come on. An active diagnostic code will be generated. The ECM will log the diagnostic code.

Possible Performance Effect:

The engine will be derated while this diagnostic code is active.

Troubleshooting:

Perform the following diagnostic procedure: "Injector Data Incorrect - Test"

Results:

- OK – STOP.

Conditions Which Generate This Code:

This diagnostic code is designed to indicate an open circuit (low current). The open circuit can be in either the solenoid or the wiring for the electronic unit injector for No. 1 cylinder.

The Electronic Control Module (ECM) detects the following condition:

- A low current condition (open circuit) for each of five consecutive attempts to operate
- Battery voltage is higher than 9 VDC for 2 seconds.

System Response:

If equipped, the warning light will come on. The ECM will log the diagnostic code.

Possible Performance Effect:

The engine will have low power and/or rough running.

Troubleshooting:

When an injector cutout test is performed, a faulty electronic unit injector will indicate a low reading in comparison with the other electronic unit injectors.

An electrical fault can prevent the electronic unit injector from operating. An open circuit in the wiring that is unique to the electronic unit injector will prevent that individual electronic unit injector from operating. An open circuit in common wiring within the ECM can prevent the three electronic unit injectors that share that common wiring from operating.

The ECM will continue to attempt to operate the electronic unit injector after the diagnostic code has been logged but an open circuit will prevent the operation of the electronic unit injector.

Perform the following diagnostic procedure: "Injector Solenoid Circuit - Test"

Results:

- OK – STOP.

i04053150

i03449840

CID 0001 FMI 06

Conditions Which Generate This Code:

This diagnostic code is designed to indicate a short circuit (high current). The short circuit can be in either the solenoid or the wiring for the electronic unit injector for No. 1 cylinder.

The Electronic Control Module (ECM) detects the following conditions:

- A high current condition (short circuit) for each of five consecutive attempts to operate
- Battery voltage above 9 VDC for 2 seconds

System Response:

If equipped, the warning light will come on. The ECM will log the diagnostic code.

Possible Performance Effect:

The engine will have low power and/or rough running.

Troubleshooting:

When an injector cutout test is performed, a faulty electronic unit injector will indicate a low reading in comparison with the other electronic unit injectors.

An electrical fault can prevent the electronic unit injector from operating. A short circuit in the wiring or the ECM that is unique to one electronic unit injector will prevent that individual electronic unit injector from operating. A short circuit in common wiring within the ECM can prevent the three electronic unit injectors that share that common wiring from operating.

The ECM will continue to attempt to operate the electronic unit injector after the diagnostic code has been logged. A short circuit will prevent the operation of the electronic unit injector.

Perform the following diagnostic procedure: "Injector Solenoid Circuit - Test"

Results:

- OK – STOP.

CID 0001 FMI 07

Conditions Which Generate This Code:

The electronic unit injector is no longer capable of delivering the correct amount of fuel.

System Response:

If equipped, the warning light will come on. The Electronic Control Module (ECM) will log the diagnostic code.

Possible Performance Effect:

The engine will be derated.

Troubleshooting:

Use the electronic service tool to perform the Verification Test for the fuel system. If the diagnostic code is still active, do the following procedure.

Replace the suspect electronic unit injector. Refer to Disassembly and Assembly, "Electronic Unit Injector - Remove" and Disassembly and Assembly, "Electronic Unit Injector - Install".

Use the electronic service tool to perform the verification test for the fuel system.

Perform the following diagnostic procedure: "None"

Results:

- OK – STOP.

i02655552

CID 0002 FMI 02

Conditions Which Generate This Code:

The Electronic Control Module (ECM) detects the following condition:

- Data from the electronic unit injector for the No. 2 cylinder is out of limits.
- Diagnostic code 0168-01 is not active.
- Diagnostic codes 0001-05 and 0001-06 are not active.
- No 0041 diagnostic codes are active.
- No 0262 diagnostic codes are active.

- Diagnostic code 0190-08 is not active.
- No 0110 diagnostic codes are active.

System Response:

If equipped, the warning light will come on. An active diagnostic code will be generated. The ECM will log the diagnostic code.

Possible Performance Effect:

The engine will be derated while this diagnostic code is active.

Troubleshooting:

Perform the following diagnostic procedure: "Injector Data Incorrect - Test"

Results:

- OK – STOP.

i04055630

CID 0002 FMI 05

Conditions Which Generate This Code:

This diagnostic code is designed to indicate an open circuit (low current) in either the solenoid or the wiring for the electronic unit injector for No. 2 cylinder.

The Electronic Control Module (ECM) detects the following condition:

- A low current condition (open circuit) for each of five consecutive attempts to operate
- Battery voltage is higher than 9 VDC for 2 seconds.

System Response:

If equipped, the warning light will come on. The ECM will log the diagnostic code.

Possible Performance Effect:

The engine will have low power and/or rough running.

Troubleshooting:

When an injector cutout test is performed, a faulty electronic unit injector will indicate a low reading in comparison with the other electronic unit injectors.

An electrical fault can prevent the electronic unit injector from operating. An open circuit in the wiring that is unique to the electronic unit injector will prevent that individual electronic unit injector from operating. An open circuit in common wiring within the ECM can prevent the three electronic unit injectors that share that common wiring from operating.

The ECM will continue to attempt to operate the electronic unit injector after the diagnostic code has been logged but an open circuit will prevent the operation of the electronic unit injector.

Perform the following diagnostic procedure: "Injector Solenoid Circuit - Test"

Results:

- OK – STOP.

i04055631

CID 0002 FMI 06

Conditions Which Generate This Code:

This diagnostic code is designed to indicate a short circuit (high current). The short circuit can be in either the solenoid or the wiring for the electronic unit injector for No. 2 cylinder.

The Electronic Control Module (ECM) detects the following conditions:

- A high current condition (short circuit) for each of five consecutive attempts to operate
- Battery voltage above 9 VDC for 2 seconds

System Response:

If equipped, the warning light will come on. The ECM will log the diagnostic code.

Possible Performance Effect:

The engine will have low power and/or rough running.

Troubleshooting:

When an injector cutout test is performed, a faulty electronic unit injector will indicate a low reading in comparison with the other electronic unit injectors.

An electrical fault can prevent the electronic unit injector from operating. A short circuit in the wiring or the ECM that is unique to one electronic unit injector will prevent that individual electronic unit injector from operating. A short circuit in common wiring within the ECM can prevent the three electronic unit injectors that share that common wiring from operating.

i02655554

The ECM will continue to attempt to operate the electronic unit injector after the diagnostic code has been logged but a short circuit will prevent the operation of the electronic unit injector.

Perform the following diagnostic procedure: "Injector Solenoid Circuit - Test"

Results:

- OK – STOP.

i03449880

CID 0002 FMI 07**Conditions Which Generate This Code:**

The electronic unit injector is no longer capable of delivering the correct amount of fuel.

System Response:

If equipped, the warning light will come on. The Electronic Control Module (ECM) will log the diagnostic code.

Possible Performance Effect:

The engine will be derated.

Troubleshooting:

Use the electronic service tool to perform the Verification Test for the Fuel System. If the diagnostic code is still active, do the following procedure.

Replace the suspect electronic unit injector. Refer to Disassembly and Assembly, "Electronic Unit Injector - Remove" and Disassembly and Assembly, "Electronic Unit Injector - Install".

Use the electronic service tool to perform the Verification Test for the Fuel System.

Perform the following diagnostic procedure: "None"

Results:

- OK – STOP.

CID 0003 FMI 02**Conditions Which Generate This Code:**

The Electronic Control Module (ECM) detects the following condition:

- Data from the electronic unit injector for the No. 3 cylinder is out of limits.
- Diagnostic code 0168-01 is not active.
- Diagnostic codes 0001-05 and 0001-06 are not active.
- No 0041 diagnostic codes are active.
- No 0262 diagnostic codes are active.
- Diagnostic code 0190-08 is not active.
- No 0110 diagnostic codes are active.

System Response:

If equipped, the warning light will come on. An active diagnostic code will be generated. The ECM will log the diagnostic code.

Possible Performance Effect:

The engine will be derated while this diagnostic code is active.

Troubleshooting:

Perform the following diagnostic procedure: "Injector Data Incorrect - Test"

Results:

- OK – STOP.

i04053169

CID 0003 FMI 05**Conditions Which Generate This Code:**

This diagnostic code is designed to indicate an open circuit (low current). The open circuit can be in either the solenoid or the wiring for the electronic unit injector for No. 3 cylinder.

The Electronic Control Module (ECM) detects the following condition:

- A low current condition (open circuit) for each of five consecutive attempts to operate
- Battery voltage is higher than 9 VDC for 2 seconds.

System Response:

If equipped, the warning light will come on. The ECM will log the diagnostic code.

Possible Performance Effect:

The engine will have low power and/or rough running.

Troubleshooting:

When an injector cutout test is performed, a faulty electronic unit injector will indicate a low reading in comparison with the other electronic unit injectors.

An electrical fault can prevent the electronic unit injector from operating. An open circuit in the wiring that is unique to the electronic unit injector will prevent that individual electronic unit injector from operating. An open circuit in common wiring within the ECM can prevent the three electronic unit injectors that share that common wiring from operating.

The ECM will continue to attempt to operate the electronic unit injector after the diagnostic code has been logged but an open circuit will prevent the operation of the electronic unit injector.

Perform the following diagnostic procedure: "Injector Solenoid Circuit - Test"

Results:

- OK – STOP.

i04053170

CID 0003 FMI 06

Conditions Which Generate This Code:

This diagnostic code is designed to indicate a short circuit (high current). The short circuit can be in either the solenoid or the wiring for the electronic unit injector for No. 3 cylinder.

The Electronic Control Module (ECM) detects the following conditions:

- A high current condition (short circuit) for each of five consecutive attempts to operate
- Battery voltage above 9 VDC for 2 seconds

System Response:

If equipped, the warning light will come on. The ECM will log the diagnostic code.

Possible Performance Effect:

The engine will have low power and/or rough running.

Troubleshooting:

When an injector cutout test is performed, a faulty electronic unit injector will indicate a low reading in comparison with the other electronic unit injectors.

An electrical fault can prevent the electronic unit injector from operating. A short circuit in the wiring or the ECM that is unique to one electronic unit injector will prevent that individual electronic unit injector from operating. A short circuit in common wiring within the ECM can prevent the three electronic unit injectors that share that common wiring from operating.

The ECM will continue to attempt to operate the electronic unit injector after the diagnostic code has been logged but a short circuit will prevent the operation of the electronic unit injector.

Perform the following diagnostic procedure: "Injector Solenoid Circuit - Test"

Results:

- OK – STOP.

i03449882

CID 0003 FMI 07

Conditions Which Generate This Code:

The electronic unit injector is no longer capable of delivering the correct amount of fuel.

System Response:

If equipped, the warning light will come on. The Electronic Control Module (ECM) will log the diagnostic code.

Possible Performance Effect:

The engine will be derated.

Troubleshooting:

Use the electronic service tool to perform the Verification Test for the Fuel System. If the diagnostic code is still active, do the following procedure.

i04053174

Replace the suspect electronic unit injector. Refer to Disassembly and Assembly, "Electronic Unit Injector - Remove" and Disassembly and Assembly, "Electronic Unit Injector - Install".

Use the electronic service tool to perform the Verification Test for the Fuel System.

Perform the following diagnostic procedure: "None"

Results:

- OK – STOP.

i02655555

CID 0004 FMI 02

Conditions Which Generate This Code:

The Electronic Control Module (ECM) detects the following condition:

- Data from the electronic unit injector for the No. 4 cylinder is out of limits.
- Diagnostic code 0168-01 is not active.
- Diagnostic codes 0001-05 and 0001-06 are not active.
- No 0041 diagnostic codes are active.
- No 0262 diagnostic codes are active.
- Diagnostic code 0190-08 is not active.
- No 0110 diagnostic codes are active.

System Response:

If equipped, the warning light will come on. An active diagnostic code will be generated. The ECM will log the diagnostic code.

Possible Performance Effect:

The engine will be derated while this diagnostic code is active.

Troubleshooting:

Perform the following diagnostic procedure: "Injector Data Incorrect - Test"

Results:

- OK – STOP.

CID 0004 FMI 05

Conditions Which Generate This Code:

This diagnostic code is designed to indicate an open circuit (low current) in either the solenoid or the wiring for the electronic unit injector for No. 4 cylinder.

The Electronic Control Module (ECM) detects the following condition:

- A low current condition (open circuit) for each of five consecutive attempts to operate
- Battery voltage is higher than 9 VDC for 2 seconds.

System Response:

If equipped, the warning light will come on. The ECM will log the diagnostic code.

Possible Performance Effect:

The engine will have low power and/or rough running.

Troubleshooting:

When an injector cutout test is performed, a faulty electronic unit injector will indicate a low reading in comparison with the other electronic unit injectors.

An electrical fault can prevent the electronic unit injector from operating. An open circuit in the wiring that is unique to the electronic unit injector will prevent that individual electronic unit injector from operating. An open circuit in common wiring within the ECM can prevent the three electronic unit injectors that share that common wiring from operating.

The ECM will continue to attempt to operate the electronic unit injector after the diagnostic code has been logged but an open circuit will prevent the operation of the electronic unit injector.

Perform the following diagnostic procedure: "Injector Solenoid Circuit - Test"

Results:

- OK – STOP.

i04053176

i03449922

CID 0004 FMI 06

Conditions Which Generate This Code:

This diagnostic code is designed to indicate a short circuit (high current). The short circuit can be in either the solenoid or the wiring for the electronic unit injector for No. 4 cylinder.

The Electronic Control Module (ECM) detects the following conditions:

- A high current condition (short circuit) for each of five consecutive attempts to operate
- Battery voltage above 9 VDC for 2 seconds

System Response:

If equipped, the warning light will come on. The ECM will log the diagnostic code.

Possible Performance Effect:

The engine will have low power and/or rough running.

Troubleshooting:

When an injector cutout test is performed, a faulty electronic unit injector will indicate a low reading in comparison with the other electronic unit injectors.

An electrical fault can prevent the electronic unit injector from operating. A short circuit in the wiring or the ECM that is unique to one electronic unit injector will prevent that individual electronic unit injector from operating. A short circuit in common wiring within the ECM can prevent the three electronic unit injectors that share that common wiring from operating.

The ECM will continue to attempt to operate the electronic unit injector after the diagnostic code has been logged but a short circuit will prevent the operation of the electronic unit injector.

Perform the following diagnostic procedure: "Injector Solenoid Circuit - Test"

Results:

- OK – STOP.

CID 0004 FMI 07

Conditions Which Generate This Code:

The electronic unit injector is no longer capable of delivering the correct amount of fuel.

System Response:

If equipped, the warning light will come on. The Electronic Control Module (ECM) will log the diagnostic code.

Possible Performance Effect:

The engine will be derated.

Troubleshooting:

Use the electronic service tool to perform the Verification Test for the Fuel System. If the diagnostic code is still active, do the following procedure.

Replace the suspect electronic unit injector. Refer to Disassembly and Assembly, "Electronic Unit Injector - Remove" and Disassembly and Assembly, "Electronic Unit Injector - Install".

Use the electronic service tool to perform the Verification Test for the Fuel System.

Perform the following diagnostic procedure: "None"

Results:

- OK – STOP.

i02655556

CID 0005 FMI 02

Conditions Which Generate This Code:

This diagnostic code is applicable to six cylinder engines only.

The Electronic Control Module (ECM) detects the following condition:

- Data from the electronic unit injector for the No. 5 cylinder is out of limits.
- Diagnostic code 0168-01 is not active.
- Diagnostic codes 0001-05 and 0001-06 are not active.

- No 0041 diagnostic codes are active.
- No 0262 diagnostic codes are active.
- Diagnostic code 0190-08 is not active.
- No 0110 diagnostic codes are active.

System Response:

If equipped, the warning light will come on. An active diagnostic code will be generated. The ECM will log the diagnostic code.

Possible Performance Effect:

The engine will be derated while this diagnostic code is active.

Troubleshooting:

Perform the following diagnostic procedure: "Injector Data Incorrect - Test"

Results:

- OK – STOP.

i04053180

CID 0005 FMI 05**Conditions Which Generate This Code:**

This diagnostic code is applicable to six cylinder engines only.

This diagnostic code is designed to indicate an open circuit (low current) in either the solenoid or the wiring for the electronic unit injector for No. 5 cylinder.

The Electronic Control Module (ECM) detects the following condition:

- A low current condition (open circuit) for each of five consecutive attempts to operate
- Battery voltage is higher than 9 VDC for 2 seconds.

System Response:

If equipped, the warning light will come on. The ECM will log the diagnostic code.

Possible Performance Effect:

The engine will have low power and/or rough running.

Troubleshooting:

When an injector cutout test is performed, a faulty electronic unit injector will indicate a low reading in comparison with the other electronic unit injectors.

An electrical fault can prevent the electronic unit injector from operating. An open circuit in the wiring that is unique to the electronic unit injector will prevent that individual electronic unit injector from operating. An open circuit in common wiring within the ECM can prevent the three electronic unit injectors that share that common wiring from operating.

The ECM will continue to attempt to operate the electronic unit injector after the diagnostic code has been logged but an open circuit will prevent the operation of the electronic unit injector.

Perform the following diagnostic procedure: "Injector Solenoid Circuit - Test"

Results:

- OK – STOP.

i04053183

CID 0005 FMI 06**Conditions Which Generate This Code:**

This diagnostic code is applicable to six cylinder engines only.

This diagnostic code is designed to indicate a short circuit (high current). The short circuit can be in either the solenoid or the wiring for the electronic unit injector for No. 5 cylinder.

The Electronic Control Module (ECM) detects the following conditions:

- A high current condition (short circuit) for each of five consecutive attempts to operate
- Battery voltage above 9 VDC for 2 seconds

System Response:

If equipped, the warning light will come on. The ECM will log the diagnostic code.

Possible Performance Effect:

The engine will have low power and/or rough running.

Troubleshooting:

When an injector cutout test is performed, a faulty electronic unit injector will indicate a low reading in comparison with the other electronic unit injectors.

An electrical fault can prevent the electronic unit injector from operating. A short circuit in the wiring or the ECM that is unique to one electronic unit injector will prevent that individual electronic unit injector from operating. A short circuit in common wiring within the ECM can prevent the three electronic unit injectors that share that common wiring from operating.

The ECM will continue to attempt to operate the electronic unit injector after the diagnostic code has been logged but a short circuit will prevent the operation of the electronic unit injector.

Perform the following diagnostic procedure: "Injector Solenoid Circuit - Test"

Results:

- OK – STOP.

i03449942

CID 0005 FMI 07

Conditions Which Generate This Code:

This diagnostic code is applicable to six cylinder engines only.

The electronic unit injector is no longer capable of delivering the correct amount of fuel.

System Response:

If equipped, the warning light will come on. The Electronic Control Module (ECM) will log the diagnostic code.

Possible Performance Effect:

The engine will be derated.

Troubleshooting:

Use the electronic service tool to perform the Verification Test on the fuel system. If the diagnostic code is still active, do the following procedure.

Replace the suspect electronic unit injector. Refer to Disassembly and Assembly, "Electronic Unit Injector - Remove" and Disassembly and Assembly, "Electronic Unit Injector - Install".

Use the electronic service tool to perform the Verification Test on the fuel system.

Perform the following diagnostic procedure: "None"

Results:

- OK – STOP.

i0265557

CID 0006 FMI 02

Conditions Which Generate This Code:

This diagnostic code is applicable to six cylinder engines only.

The Electronic Control Module (ECM) detects the following condition:

- Data from the electronic unit injector for the No. 6 cylinder is out of limits.
- Diagnostic code 0168-01 is not active.
- Diagnostic codes 0001-05 and 0001-06 are not active.
- No 0041 diagnostic codes are active.
- No 0262 diagnostic codes are active.
- Diagnostic code 0190-08 is not active.
- No 0110 diagnostic codes are active.

System Response:

If equipped, the warning light will come on. An active diagnostic code will be generated. The ECM will log the diagnostic code.

Possible Performance Effect:

The engine will be derated while this diagnostic code is active.

Troubleshooting:

Perform the following diagnostic procedure: "Injector Data Incorrect - Test"

Results:

- OK – STOP.

i04053185

i04053192

CID 0006 FMI 05

Conditions Which Generate This Code:

This diagnostic code is applicable to six cylinder engines only.

This diagnostic code is designed to indicate an open circuit (low current) in either the solenoid or the wiring for the electronic unit injector for No. 6 cylinder.

The Electronic Control Module (ECM) detects the following condition:

- A low current condition (open circuit) for each of five consecutive attempts to operate
- Battery voltage is higher than 9 VDC for 2 seconds.

System Response:

If equipped, the warning light will come on. The ECM will log the diagnostic code.

Possible Performance Effect:

The engine will have low power and/or rough running.

Troubleshooting:

When an injector cutout test is performed, a faulty electronic unit injector will indicate a low reading in comparison with the other electronic unit injectors.

An electrical fault can prevent the electronic unit injector from operating. An open circuit in the wiring that is unique to the electronic unit injector will prevent that individual electronic unit injector from operating. An open circuit in common wiring within the ECM can prevent the three electronic unit injectors that share that common wiring from operating.

The ECM will continue to attempt to operate the electronic unit injector after the diagnostic code has been logged but an open circuit will prevent the operation of the electronic unit injector.

Perform the following diagnostic procedure: "Injector Solenoid Circuit - Test"

Results:

- OK – STOP.

CID 0006 FMI 06

Conditions Which Generate This Code:

This diagnostic code is applicable to six cylinder engines only.

This diagnostic code is designed to indicate a short circuit (high current). The short circuit can be in either the solenoid or the wiring for the electronic unit injector for No. 6 cylinder.

The Electronic Control Module (ECM) detects the following conditions:

- A high current condition (short circuit) for each of five consecutive attempts to operate
- Battery voltage above 9 VDC for 2 seconds

System Response:

If equipped, the warning light will come on. The ECM will log the diagnostic code.

Possible Performance Effect:

The engine will have low power and/or rough running.

Troubleshooting:

When an injector cutout test is performed, a faulty electronic unit injector will indicate a low reading in comparison with the other electronic unit injectors.

An electrical fault can prevent the electronic unit injector from operating. A short circuit in the wiring or the ECM that is unique to one electronic unit injector will prevent that individual electronic unit injector from operating. A short circuit in common wiring within the ECM can prevent the three electronic unit injectors that share that common wiring from operating.

The ECM will continue to attempt to operate the electronic unit injector after the diagnostic code has been logged but a short circuit will prevent the operation of the electronic unit injector.

Perform the following diagnostic procedure: "Injector Solenoid Circuit - Test"

Results:

- OK – STOP.

i03449944

CID 0006 FMI 07

Conditions Which Generate This Code:

This diagnostic code is applicable to six cylinder engines only.

The electronic unit injector is no longer capable of delivering the correct amount of fuel.

System Response:

If equipped, the warning light will come on. The Electronic Control Module (ECM) will log the diagnostic code.

Possible Performance Effect:

The engine will be derated.

Troubleshooting:

Use the electronic service tool to perform the Verification Test on the fuel system. If the diagnostic code is still active, do the following procedure.

Replace the suspect electronic unit injector. Refer to Disassembly and Assembly, "Electronic Unit Injector - Remove" and Disassembly and Assembly, "Electronic Unit Injector - Install".

Use the electronic service tool to perform the Verification Test on the fuel system.

Perform the following diagnostic procedure: "None"

Results:

- OK – STOP.

i04015637

CID 0041 FMI 03

Conditions Which Generate This Code:

The Electronic Control Module (ECM) detects the following conditions:

- The 8 V supply is more than 8.8 VDC for more than one second.
- The ECM has been powered for more than 3 seconds.

System Response:

The ECM will log the diagnostic code and the diagnostic lamp will illuminate while this diagnostic code is active.

Possible Performance Effect:

The engine may be limited to low idle.

Note: The 8 V supply provides power to the two speed/timing sensors.

Troubleshooting:

Perform the following diagnostic procedure: "Engine Speed/Timing Sensor Circuit - Test"

Results:

- OK – STOP.

i04020999

CID 0041 FMI 04

Conditions Which Generate This Code:

The Electronic Control Module (ECM) detects the following conditions:

- The 8 V supply is less than 7.2 VDC for more than one second.
- The ECM has been powered for more than 3 seconds.
- Diagnostic code 0168-01 is not active.

System Response:

The ECM will log the diagnostic code and the diagnostic lamp will illuminate while this diagnostic code is active. An active diagnostic code may not cause any noticeable effect on engine response unless the voltage drops below 6.5 VDC.

Possible Performance Effect:

The engine may be limited to low idle.

Note: The 8 V supply provides power to the two speed/timing sensors.

Troubleshooting:

Perform the following diagnostic procedure: "Engine Speed/Timing Sensor Circuit - Test"

Results:

- OK – STOP.

i04015670

CID 0091 FMI 08**Conditions Which Generate This Code:**

The Electronic Control Module (ECM) detects an incorrect frequency on the throttle signal or the throttle position sensor is out of the acceptable range.

System Response:

The code is logged. The ECM flags the throttle position as invalid data and a default value of zero percent is used.

If equipped, the diagnostic light will be on. The diagnostic code will be logged if the engine is running. The diagnostic code will not be logged if the engine is cranking.

Possible Performance Effect:

- The engine will default to the low idle speed.
- The engine will remain at this speed while the diagnostic code remains active.
- All inputs from the faulty throttle are ignored by the ECM until the fault is repaired.

Troubleshooting:

This diagnostic code indicates that the frequency of a digital throttle signal is out of the normal range.

Perform the following diagnostic procedure: “Throttle Position Sensor - Test”

Results:

- OK – STOP.

i04010629

CID 0091 FMI 13**Conditions Which Generate This Code:**

The duty cycle of the signal from the throttle that is connected to the primary throttle input is incorrect.

System Response:

The Electronic Control Module (ECM) will log the diagnostic code. The ECM flags the throttle position as invalid data and a default value of zero percent is used.

Possible Performance Effect:

- The engine speed is limited to low idle.

Troubleshooting:

Perform the following diagnostic procedure: “Throttle Position Sensor - Test”

Results:

- OK – STOP.

i04018152

CID 0094 FMI 03**Conditions Which Generate This Code:**

The Electronic Control Module (ECM) reads signal voltage that is above normal.

System Response:

The ECM will log the diagnostic code. The ECM flags fuel pressure as invalid data and a default value is used.

Possible Performance Effect:

- There are no performance effects.

Troubleshooting:

Perform the following diagnostic procedure: “Engine Pressure Sensor Open or Short Circuit - Test”

Results:

- OK – STOP.

i04018153

CID 0094 FMI 04**Conditions Which Generate This Code:**

The Electronic Control Module (ECM) reads signal voltage that is below normal.

System Response:

The ECM will log the diagnostic code. The ECM flags fuel pressure as invalid data and a default value is used.

Possible Performance Effect:

- There are no performance effects.

Troubleshooting:

Perform the following diagnostic procedure: "Engine Pressure Sensor Open or Short Circuit - Test"

Results:

- OK – STOP.

i04018154

CID 0096 FMI 03

Conditions Which Generate This Code:

The voltage on the signal wire for the fuel level sensor is above normal.

System Response:

The Electronic Control Module (ECM) will log the diagnostic code.

Possible Performance Effect:

- There are no performance effects.

Troubleshooting:

Perform the following diagnostic procedure: "Fuel Level - Test"

Results:

- OK – STOP.

i04018155

CID 0096 FMI 04

Conditions Which Generate This Code:

The voltage on the signal wire for the fuel level sensor is below normal.

System Response:

The Electronic Control Module (ECM) will log the diagnostic code.

Possible Performance Effect:

- There are no performance effects.

Troubleshooting:

Perform the following diagnostic procedure: "Fuel Level - Test"

Results:

- OK – STOP.

i04015729

CID 0100 FMI 03

Conditions Which Generate This Code:

The Electronic Control Module (ECM) detects the following conditions:

- The signal voltage from the engine oil pressure sensor is greater than 4.95 VDC for more than 8 seconds.
- The ECM has been powered for at least 2 seconds.
- The engine is not running or the engine coolant temperature is greater than 38 °C (100 °F).

System Response:

The ECM will log the diagnostic code. If equipped, the diagnostic lamp will come on. The ECM will set data for engine oil pressure to the default value.

Note: The engine oil pressure that is displayed on the electronic service tool is the default value for engine oil pressure. The default engine oil pressure is 600 kPa (87 psi). The electronic service tool will display "Voltage Above Normal" on the status screens.

Possible Performance Effect:

None

Troubleshooting:

This diagnostic code can be caused by an open circuit or a short to another power source.

Perform the following diagnostic procedure: "Engine Pressure Sensor Open or Short Circuit - Test"

Results:

- OK – STOP.

i04015731

CID 0100 FMI 04**Conditions Which Generate This Code:**

The Electronic Control Module (ECM) detects the following conditions:

- The signal voltage from the engine oil pressure sensor is less than 0.1 VDC for more than 8 seconds.
- The ECM has been powered for at least 2 seconds.
- The engine is running.

System Response:

The ECM will log the diagnostic code. If equipped, the diagnostic lamp will come on. The ECM will set data for engine oil pressure to the default value. The electronic service tool will display “Voltage Below Normal” on the status screens.

Possible Performance Effect:

None

Troubleshooting:

This code can be caused by a short to ground or a shorted sensor.

Perform the following diagnostic procedure: “Engine Pressure Sensor Open or Short Circuit - Test”

Results:

- OK – STOP.

i04015742

CID 0100 FMI 10**Conditions Which Generate This Code:**

The Electronic Control Module (ECM) detects the following conditions:

- No other codes for the oil pressure sensor are active.

- No 0262 diagnostic codes are active for the 5 V supply.
- The engine speed is greater than 600 rpm.
- The engine oil pressure signal is within the limits of 410 kPa (59 psi) to 520 kPa (75 psi) with a pressure variation of less than 1.68 kPa (0.25 psi) for more than 30 seconds.
- The engine oil pressure signal remains constant for 30 seconds.

System Response:

If equipped, the diagnostic lamp will be on. The ECM will log the diagnostic code.

The ECM will flag the engine oil pressure as invalid data. The data for engine oil pressure is set to a default value of 500 kPa (72 psi). The electronic service tool will display “Conditions Not Met” on the status screen.

Possible Performance Effect:

None

Troubleshooting:

This diagnostic code will detect the loss of the 5 V supply to the sensor.

Perform the following diagnostic procedure: “Engine Pressure Sensor Open or Short Circuit - Test”

Results:

- OK – STOP.

i04015755

CID 0110 FMI 03**Conditions Which Generate This Code:**

The Electronic Control Module (ECM) detects the following conditions:

- The signal voltage from the engine coolant temperature sensor is greater than 4.95 VDC for more than 8 seconds.
- The ECM has been powered for at least 2 seconds.

System Response:

If equipped, the diagnostic light will be on. An active diagnostic code will be generated after 8 seconds. The diagnostic code will be logged if the engine has been operating for more than 7 minutes.

The ECM will default to 90 °C (194 °F) for engine coolant temperature. “Voltage Above Normal” will be displayed next to the status for “Engine Coolant Temperature” on the electronic service tool.

Possible Performance Effect:

- Poor stability
- Poor cold running
- White smoke

Troubleshooting:

The diagnostic code will detect an excessively high voltage from the engine coolant temperature sensor.

Perform the following diagnostic procedure: “Engine Temperature Sensor Open or Short Circuit - Test”

Results:

- OK – STOP.

i04015769

CID 0110 FMI 04

Conditions Which Generate This Code:

The Electronic Control Module (ECM) detects the following conditions:

- The signal voltage from the engine coolant temperature sensor is less than 0.2 VDC for more than 8 seconds.
- The ECM has been powered for at least 2 seconds.
- Diagnostic code 0168-01 is not active.

System Response:

The ECM will default to 90 °C (194 °F) for engine coolant temperature. “Voltage Below Normal” will be displayed next to the status for “Engine Coolant Temperature” on the electronic service tool.

If equipped, the diagnostic light will come on. An active diagnostic code will be generated after 8 seconds. The diagnostic code will be logged if the engine has been operating for more than 7 minutes.

Possible Performance Effect:

- Poor stability
- Poor cold running
- White smoke

Troubleshooting:

The diagnostic code will detect an excessively low voltage from the engine coolant temperature sensor.

Perform the following diagnostic procedure: “Engine Temperature Sensor Open or Short Circuit - Test”

Results:

- OK – STOP.

i04012454

CID 0127 FMI 03

Conditions Which Generate This Code:

The signal from the marine transmission oil pressure sensor is above normal.

System Response:

The Electronic Control Module (ECM) will log the diagnostic code. The ECM flags marine transmission oil pressure as invalid data.

Possible Performance Effect:

- There are no performance effects.

Troubleshooting:

Perform the following diagnostic procedure: “Engine Pressure Sensor Open or Short Circuit - Test”

Results:

- OK – STOP.

i04012455

CID 0127 FMI 04

Conditions Which Generate This Code:

The signal from the marine transmission oil pressure sensor is below normal.

System Response:

The Electronic Control Module (ECM) will log the diagnostic code. The ECM flags marine transmission oil pressure as invalid data.

Possible Performance Effect:

- There are no performance effects.

Troubleshooting:

Perform the following diagnostic procedure: "Engine Pressure Sensor Open or Short Circuit - Test"

Results:

- OK – STOP.

i04010650

CID 0168 FMI 00**Conditions Which Generate This Code:**

The ECM detects the following conditions:

- The battery voltage to the ECM exceeds 32 VDC for more than 0.5 seconds.
- The keyswitch is in the ON mode.
- The engine is not cranking.
- The engine is running for more than 30 seconds.

System Response:

The ECM will log the diagnostic code. If equipped, the diagnostic lamp may come on.

Possible Performance Effect:

None

Troubleshooting:

This diagnostic code will detect excessively high voltage in the battery circuit to the Electronic Control Module (ECM) while the engine is running.

Perform the following diagnostic procedure: "Ignition Keyswitch Circuit and Battery Supply Circuit - Test"

Results:

- OK – STOP.

i04010671

CID 0168 FMI 01**Conditions Which Generate This Code:**

The ECM detects the following conditions:

- The keyswitch is in the ON position.

- The engine is not cranking.
- The engine is running for more than 3 seconds.
- The battery voltage to the ECM is below 9 VDC for more than 0.5 seconds.

System Response:

If equipped, the diagnostic lamp may come on. The ECM will normally log the diagnostic code. If battery voltage disappears without returning, the ECM will not log this diagnostic code and the engine will shut down.

The engine will derate 100 percent.

Possible Performance Effect:

The engine may experience changes in the engine rpm, and intermittent engine shutdowns or complete engine shutdowns.

Troubleshooting:

This diagnostic code will detect low voltage in the battery circuit for the Electronic Control Module (ECM) while the engine is running.

Perform the following diagnostic procedure: "Ignition Keyswitch Circuit and Battery Supply Circuit - Test"

Results:

- OK – STOP.

i04015773

CID 0168 FMI 02**Conditions Which Generate This Code:**

The ECM detects the following conditions:

- Three voltage readings that are below 6 VDC in a period of 7 seconds will be detected by the ECM. The voltage must increase to more than 9 VDC.
- The keyswitch is in the ON position.
- The engine is running.
- The engine is not cranking.

System Response:

The diagnostic code will normally be logged. If the battery voltage disappears without returning, the ECM will not log this diagnostic code and the engine will shut down. This will be dependent on the length of time of the occurrence of the fault.

The diagnostic lamp may come on.

Possible Performance Effect:

The engine may experience changes in the engine rpm. The engine may experience intermittent engine shutdowns or complete engine shutdowns while the conditions that cause this diagnostic code are present.

Troubleshooting:

This diagnostic code detects intermittent voltage in the battery circuit for the Electronic Control Module (ECM) while the engine is running.

Perform the following diagnostic procedure: "Ignition Keyswitch Circuit and Battery Supply Circuit - Test"

Results:

- OK – STOP.

i04015778

CID 0172 FMI 03

Conditions Which Generate This Code:

The Electronic Control Module (ECM) detects the following conditions:

- The signal voltage from the intake manifold air temperature sensor is greater than 4.95 VDC for more than 8 seconds.
- Engine coolant temperature is above -10 °C (15.0 °F).
- The ECM has been powered for at least 2 seconds.
- Diagnostic code 0168-01 is not active.

System Response:

If equipped, the diagnostic light will come on. The ECM will log the diagnostic code.

The ECM will use the default value of 70 °C (158 °F) for the intake manifold air temperature. "Voltage High" will be displayed next to the status for "Intake Manifold Air Temperature" on the electronic service tool.

Possible Performance Effect:

- Poor stability
- Poor cold running
- White smoke

- Black smoke
- Poor acceleration under load

Troubleshooting:

This fault can be caused by an open circuit or a short to a power source.

Perform the following diagnostic procedure: "Engine Temperature Sensor Open or Short Circuit - Test"

Results:

- OK – STOP.

i04015780

CID 0172 FMI 04

Conditions Which Generate This Code:

The Electronic Control Module (ECM) detects the following conditions:

- The signal voltage from the intake manifold air temperature sensor is less than 0.2 VDC for more than 8 seconds.
- The ECM has been powered for at least 2 seconds.
- Diagnostic code 0168-01 is not active.

System Response:

If equipped, the diagnostic light will come on. The ECM will log the diagnostic code.

The ECM will use the default value of 70 °C (158 °F) for the intake manifold air temperature. "Voltage Low" will be displayed next to the status for "Intake Manifold Air Temperature" on the electronic service tool.

Possible Performance Effect:

- Poor stability
- Poor cold running
- White smoke
- Black smoke
- Poor acceleration under load

Troubleshooting:

This fault can be caused by a sensor that is shorted to ground or a sensor that is internally shorted.

Perform the following diagnostic procedure: "Engine Temperature Sensor Open or Short Circuit - Test"

Results:

- OK – STOP.

i04010710

CID 0174 FMI 03**Conditions Which Generate This Code:**

The Electronic Control Module (ECM) detects a signal voltage from the sensor that is above normal.

System Response:

The ECM will log the diagnostic code. The ECM flags fuel temperature as invalid data and fuel temperature is set to a default value.

Possible Performance Effect:

- There are no performance effects.

Troubleshooting:

Perform the following diagnostic procedure: "Engine Temperature Sensor Open or Short Circuit - Test"

Results:

- OK – STOP.

i04010712

CID 0174 FMI 04**Conditions Which Generate This Code:**

The Electronic Control Module (ECM) detects signal voltage that is below normal.

System Response:

The ECM will log the diagnostic code. The ECM flags fuel temperature as invalid data and a default value is used.

Possible Performance Effect:

- There are no performance effects.

Troubleshooting:

Perform the following diagnostic procedure: "Engine Temperature Sensor Open or Short Circuit - Test"

Results:

- OK – STOP.

i04018149

CID 0177 FMI 03**Conditions Which Generate This Code:**

The signal voltage from the transmission oil temperature sensor is above normal.

System Response:

The Electronic Control Module (ECM) will log the diagnostic code. The transmission oil temperature will be set to a default value.

Possible Performance Effect:

- There are no performance effects.

Troubleshooting:

Perform the following diagnostic procedure: "Transmission Oil Temperature Sensor Open or Short Circuit - Test"

Results:

- OK – STOP.

i04018150

CID 0177 FMI 04**Conditions Which Generate This Code:**

The signal voltage from the transmission oil temperature sensor is below normal.

System Response:

The Electronic Control Module (ECM) will log the diagnostic code. The transmission oil temperature will be set to a default value.

Possible Performance Effect:

- There are no performance effects.

Troubleshooting:

i04015824

Perform the following diagnostic procedure:
“Transmission Oil Temperature Sensor Open or Short
Circuit - Test”

Results:

- OK – STOP.

i04015789

CID 0190 FMI 08

Conditions Which Generate This Code:

The Electronic Control Module (ECM) detects the following conditions:

- The ECM detected an intermittent loss of signal or a complete loss of signal from the primary speed/timing sensor for 2 seconds.
- The engine has been running for more than 3 seconds.

System Response:

If equipped, the diagnostic light will come on and the diagnostic code will be logged.

The ECM will use the signal from the secondary speed/timing sensor.

Possible Performance Effect:

The engine will be derated. If the signal from the secondary speed/timing sensor is also lost, the engine will shut down.

Troubleshooting:

This diagnostic code will detect a loss of signal from the primary speed/timing sensor.

Perform the following diagnostic procedure: “Engine Speed/Timing Sensor Circuit - Test”

Results:

- OK – STOP.

CID 0253 FMI 02

Conditions Which Generate This Code:

The Electronic Control Module (ECM) detects incorrect engine software.

System Response:

If equipped, the diagnostic light will come on.

This diagnostic code is not logged.

Factory passwords are required to clear this diagnostic code.

Possible Performance Effect:

The engine will not start.

Troubleshooting:

The flash file in the ECM is from the wrong engine family.

Use the electronic service tool to install the correct flash file into the ECM. Refer to the Troubleshooting, “Flash Programming”.

Perform the following diagnostic procedure: “None”

Results:

- OK – STOP.

i04021000

CID 0261 FMI 11

Conditions Which Generate This Code:

The Electronic Control Module (ECM) detects the following conditions:

- The outputs from the primary speed/timing sensor and the secondary speed/timing sensor differ by more than 8 degrees on the crankshaft.
- The engine has been running for more than 5 seconds.
- Diagnostic code 0190-08 is not active.
- No 0041 diagnostic codes are active.

System Response:

i03451888

If equipped, the diagnostic light will come on. This code will not be logged.

Possible Performance Effect:

The pressure in the fuel rail may be unstable and the engine may not run smoothly.

Troubleshooting:

Check the timing of the fuel rail pump. Refer to Disassembly and Assembly, "Fuel Injection Pump - Install".

Results:

- OK – STOP.

i03451885

CID 0262 FMI 03**Conditions Which Generate This Code:**

The Electronic Control Module (ECM) detects the following conditions:

- The 5 Volt supply is greater than 5.16 Volts DC for more than one second.
- The ECM has been powered for at least three seconds.
- Diagnostic code 0168-01 is not active.

System Response:

The ECM sets all of the pressure sensors and temperature sensors to the default values.

Possible Performance Effect:

The engine will be derated.

Troubleshooting:

This diagnostic code will detect an excessively high voltage in the 5 Volt supply circuit.

Perform the following diagnostic procedure: "5 Volt Sensor Supply Circuit - Test"

Results:

- OK – STOP.

CID 0262 FMI 04**Conditions Which Generate This Code:**

The Engine Control Module (ECM) detects the following conditions:

- The 5 Volt supply is less than 4.84 Volts DC for more than one second.
- The ECM has been powered for at least three seconds.
- Diagnostic code 0168-01 is not active.

System Response:

The ECM sets all of the pressure sensors and temperature sensors to the default values.

Possible Performance Effect:

The engine will be derated.

Troubleshooting:

This diagnostic code will detect an excessively low voltage in the 5 Volt supply circuit.

Perform the following diagnostic procedure: "5 Volt Sensor Supply Circuit - Test"

Results:

- OK – STOP.

i04015832

CID 0268 FMI 02**Conditions Which Generate This Code:**

The Electronic Control Module (ECM) detects one or more of the following conditions:

- One or more of the following configuration parameters are not programmed. The effect on the ECM depends on the parameter.
- FLS or FTS
- Trim codes for the injectors
- Engine serial number
- Equipment identification

- All of the injector trim files are not loaded into the ECM. Engine performance and emissions are affected.

System Response:

If equipped, the diagnostic light will come on. The fault is not logged.

The electronic service tool will display a list of the condition(s) on the "Active Diagnostics" screen that must be resolved.

Possible Performance Effect:

Engine performance and emissions are affected.

Troubleshooting:

Use the electronic service tool to correct parameters that have not been programmed or parameters that have been incorrectly programmed.

Perform the following diagnostic procedure: "Flash Programming"

Results:

- OK – STOP.

i03452010

CID 0342 FMI 08**Conditions Which Generate This Code:**

The Electronic Control Module (ECM) detects the following conditions:

- The signal from the secondary speed/timing sensor is lost and/or intermittent.
- The signal from the secondary speed/timing sensor was lost for at least 2 seconds while the signal from the primary speed/timing sensor remained valid and the engine was running.
- Diagnostic code 0168-01 is not active.
- The engine has been running for more than 3 seconds.
- No 0041 diagnostic codes are active.

System Response:

If equipped, the warning lamp will come on and the diagnostic code will be logged.

Possible Performance Effect:

If the signal from the secondary speed/timing sensor is lost and the engine is stopped, the engine will not restart. The performance will not be affected unless both speed signals are lost. The loss of the signals from both speed/timing sensors will cause the ECM to shut down the engine.

Troubleshooting:

Perform the following diagnostic procedure: "Engine Speed/Timing Sensor Circuit - Test"

Results:

- OK – STOP.

i04012809

CID 0342 FMI 11**Conditions Which Generate This Code:**

The signal for the secondary speed/timing sensor is intermittent or lost.

System Response:

The Electronic Control Module (ECM) will log the diagnostic code.

Possible Performance Effect:

There should not be a noticeable change in engine response unless the signal for the primary sensor is also lost. The loss of both sensors will shut down the engine.

Troubleshooting:

Perform the following diagnostic procedure: "Engine Speed/Timing Sensor Circuit - Test"

Results:

- OK – STOP.

i03452020

CID 0526 FMI 05**Conditions Which Generate This Code:**

This diagnostic code will only appear if an electronically controlled wastegate is installed.

The Electronic Control Module (ECM) detects the following conditions:

- A low current condition in the output from the ECM to the solenoid for the wastegate regulator
- No 0168 diagnostic codes are active.

System Response:

If equipped, the warning lamp will come on once the diagnostic code has been active for 30 seconds. The diagnostic code will be logged. After the derate has been activated, the electronic service tool will indicate "Turbo Protection Derate Active".

Possible Performance Effect:

The engine will be derated while this diagnostic code is active.

Troubleshooting:

This diagnostic code will detect a fault in the circuit for the solenoid in the wastegate regulator that is most likely to be an open circuit.

Perform the following diagnostic procedure:
"Wastegate Solenoid - Test"

Results:

- OK – STOP.

i03452040

CID 0526 FMI 06

Conditions Which Generate This Code:

This diagnostic code will only appear if an electronically controlled wastegate is installed.

The Electronic Control Module (ECM) detects the following conditions:

- A high current condition in the output from the ECM to the solenoid in the wastegate regulator
- No 0168 diagnostic codes are active.

System Response:

If equipped, the warning lamp will come on once the diagnostic code has been active for 30 seconds. The diagnostic code will be logged. After the derate has been activated, the electronic service tool will indicate "Turbo Protection Derate Active".

Possible Performance Effect:

The engine will be derated while this diagnostic code is active.

Troubleshooting:

This diagnostic code will detect a fault in the circuit for the solenoid in the wastegate regulator. This problem is most likely to be caused by a high side short to ground or a low side short to power.

Perform the following diagnostic procedure:
"Wastegate Solenoid - Test"

Results:

- OK – STOP.

i04021001

CID 0526 FMI 07

Conditions Which Generate This Code:

This diagnostic code will only appear if an electronically controlled wastegate is installed.

This diagnostic code indicates that the intake manifold pressure is not being controlled correctly.

The Electronic Control Module (ECM) will detect the following conditions:

- The ECM has been powered for more than 4 seconds.
- Diagnostic code 0168-01 is not active.
- No 1785 diagnostic codes are active.
- Diagnostic codes 0526-05 and 0526-06 are not active.
- No 0262 diagnostic codes are active.

System Response:

If equipped, the diagnostic lamp will come on and the diagnostic code will be logged.

Possible Performance Effect:

- The engine may not reach top RPM.
- The engine produces excessive black smoke.
- The engine has low power.

Troubleshooting:

i04012473

This diagnostic code will detect a mechanical problem in the intake air system. The electronic part of the control system will be operating correctly.

Perform the following diagnostic procedure: "Systems Operation, Testing and Adjusting, "Turbocharger - Inspect""

Results:

- OK – STOP.

i04012470

CID 0535 FMI 03

Conditions Which Generate This Code:

The Electronic Control Module (ECM) detects the following conditions:

- The signal voltage from the exhaust gas temperature sensor is greater than 4.95 VDC for more than 8 seconds.
- The ECM has been powered for at least 2 seconds.
- Diagnostic code 0168-01 is not active.

System Response:

If equipped, the diagnostic light will come on. The ECM will log the diagnostic code.

"Voltage High" will be displayed next to the status for "Exhaust Gas Temperature" on the electronic service tool.

Possible Performance Effect:

- There are no performance effects.

Troubleshooting:

This fault can be caused by an open circuit or a short to a power source.

Perform the following diagnostic procedure: "Engine Temperature Sensor Open or Short Circuit - Test"

Results:

- OK – STOP.

CID 0535 FMI 04

Conditions Which Generate This Code:

The Electronic Control Module (ECM) detects the following conditions:

- The signal voltage from the exhaust gas temperature sensor is less than 0.2 VDC for more than 8 seconds.
- The ECM has been powered for at least 2 seconds.
- Diagnostic code 0168-01 is not active.

System Response:

If equipped, the diagnostic light will come on. The ECM will log the diagnostic code.

"Voltage Low" will be displayed next to the status for "Exhaust Gas Temperature" on the electronic service tool.

Possible Performance Effect:

- There are no performance effects.

Troubleshooting:

This fault can be caused by a sensor that is shorted to ground or a sensor that is internally shorted.

Perform the following diagnostic procedure: "Engine Temperature Sensor Open or Short Circuit - Test"

Results:

- OK – STOP.

i04012474

CID 0774 FMI 08

Conditions Which Generate This Code:

The frequency or the duty cycle of the signal from the secondary throttle input is incorrect.

System Response:

The Electronic Control Module (ECM) will log the diagnostic code. The ECM flags the throttle position as invalid data and a default value is used.

Possible Performance Effect:

- The engine speed is limited to low idle if the secondary throttle is in operation.

Troubleshooting:

Perform the following diagnostic procedure: "Throttle Position Sensor Circuit - Test"

Results:

- OK – STOP.

i04012475

CID 0774 FMI 13**Conditions Which Generate This Code:**

The frequency or the duty cycle of the signal from the secondary throttle input is incorrect.

System Response:

The Electronic Control Module (ECM) will log the diagnostic code. The ECM flags the throttle position as invalid data and a default value is used.

Possible Performance Effect:

- The engine speed is limited to low idle.

Troubleshooting:

Perform the following diagnostic procedure: "Throttle Position Sensor - Test"

Results:

- OK – STOP.

i04016593

CID 1779 FMI 05**Conditions Which Generate This Code:**

The diagnostic code indicates that the Electronic Control Module (ECM) has detected an open circuit in the solenoid for the fuel rail. The diagnostic code indicates that the Electronic Control Module (ECM) has detected a low current condition in the solenoid for the fuel rail.

System Response:

If equipped, the diagnostic light will come on and the ECM will log the diagnostic code.

Possible Performance Effect:

An electrical fault may prevent the provision of pressure to the fuel rail. The prevention of the provision of pressure to the fuel rail may result in the loss of fuel injection. If the solenoid for the fuel rail pump fails, it is likely that fuel will not be pumped into the fuel rail. The engine will stop or the engine will not start.

Perform the following diagnostic procedure: "Fuel Rail Pump Solenoid - Test"

Results:

- OK – STOP.

i04016594

CID 1779 FMI 06**Conditions Which Generate This Code:**

The diagnostic code indicates that the Electronic Control Module (ECM) has detected a short circuit in the solenoid for the fuel rail. The diagnostic code indicates that the Electronic Control Module (ECM) has detected a high current condition in the solenoid for the fuel rail.

System Response:

If equipped, the diagnostic light will come on and the ECM will log the diagnostic code.

Possible Performance Effect:

An electrical fault may prevent the provision of pressure to the fuel rail. The prevention of the provision of pressure to the fuel rail may result in the loss of fuel injection. If the solenoid for the fuel rail pump fails, it is likely that fuel will not be pumped into the fuel rail. The engine will stop or the engine will not start.

Perform the following diagnostic procedure: "Fuel Rail Pump Solenoid - Test"

Results:

- OK – STOP.

i04016595

CID 1785 FMI 03

Conditions Which Generate This Code:

The Electronic Control Module (ECM) detects the following conditions:

- The ECM has been powered for 2 seconds.
- The signal voltage from the intake manifold pressure sensor is above 4.95 VDC for at least 2 seconds.
- This diagnostic code can be caused by an open circuit or a short to another power source.

System Response:

If equipped, the diagnostic light will be on. The diagnostic code will be logged.

The data for the intake manifold pressure will be set to a maximum valid pressure for 2 seconds. The ECM will then flag the intake manifold pressure as being invalid. A default value is then used for the intake manifold pressure.

Possible Performance Effect:

For engines with an electronically controlled wastegate, the current for the wastegate solenoid will be set to a default value while this code is active. This will cause the engine to have poor acceleration. The default setting will prevent any overpressure in the intake manifold which could be caused by an overspeed of the turbocharger.

Troubleshooting:

This diagnostic code will detect excessively high voltage from the intake manifold pressure sensor.

Perform the following diagnostic procedure: "Engine Pressure Sensor Open or Short Circuit - Test"

Results:

- OK – STOP.

i04016596

CID 1785 FMI 04

Conditions Which Generate This Code:

The Electronic Control Module (ECM) detects the following conditions:

- The signal voltage from the intake manifold pressure sensor is less than 0.2 VDC for at least 2 seconds.
- The ECM has been powered for 2 seconds.
- This code can be caused by a short to ground or a shorted sensor.
- The keyswitch is in the "ON" position so that the ECM is energized.

System Response:

If equipped, the diagnostic light will come on. The diagnostic code will be logged.

The data for the intake manifold pressure will be set to a maximum valid pressure for 2 seconds. The ECM will then flag the intake manifold pressure as being invalid. A default value is then used for the intake manifold pressure.

Possible Performance Effect:

For engines with an electronically controlled wastegate, the current for the wastegate solenoid will be set to a default value while this code is active. This will cause the engine to have poor acceleration. The default setting will prevent any overpressure in the intake manifold which could be caused by an overspeed of the turbocharger.

Troubleshooting:

This diagnostic code will detect excessively low voltage from the intake manifold pressure sensor.

Perform the following diagnostic procedure: "Engine Pressure Sensor Open or Short Circuit - Test"

Results:

- OK – STOP.

i04016597

CID 1785 FMI 10

Conditions Which Generate This Code:

This diagnostic code is designed to detect the loss of the 5 V supply at the sensor connector.

The Electronic Control Module (ECM) detects the following conditions:

- The engine speed is more than 1000 rpm.
- The intake manifold pressure is within the acceptable range.

- No 0262 codes for the 5 V supply are active.
- Diagnostic code 0168-01 is not active.

System Response:

If equipped, the diagnostic light will come on. The diagnostic code will be logged.

The ECM will flag the intake manifold pressure as being invalid. A default value is used for the intake manifold pressure.

Note: Any open circuits or short circuits in the signal wire for the oil pressure may reset the diagnostic.

Possible Performance Effect:

For engines with an electronically controlled wastegate, the current for the wastegate solenoid will be set to a default value while this code is active. This will cause the engine to have poor acceleration. The default setting will prevent any overpressure in the intake manifold which could be caused by an overspeed of the turbocharger.

The engine will be derated.

Troubleshooting:

This diagnostic code will detect the loss of the 5 V supply to the sensor.

Perform the following diagnostic procedure: "Engine Pressure Sensor Open or Short Circuit - Test"

Results:

- OK – STOP.

i04016598

CID 1797 FMI 03**Conditions Which Generate This Code:**

The Electronic Control Module (ECM) detects the following condition:

- The signal voltage for the pressure sensor in the fuel rail is more than 4.8 VDC for 0.6 seconds.

System Response:

If equipped, the diagnostic lamp will come on. The diagnostic code will be logged.

The electronic service tool will display "70000 kPa" next to "Desired Fuel Rail Pressure" and "Actual Fuel Rail Pressure" on the status screens.

Possible Performance Effect:

The engine will be derated.

Troubleshooting:

This diagnostic code detects an excessively high voltage from the fuel rail pressure sensor.

Perform the following diagnostic procedure: "Engine Pressure Sensor Open or Short Circuit - Test"

Results:

- OK – STOP.

i04019932

CID 1797 FMI 04**Conditions Which Generate This Code:**

The Electronic Control Module (ECM) detects the following conditions:

- No 0262 codes for the 5 V supply are active.
- Diagnostic code 0168-01 is not active.
- The signal voltage for the pressure sensor in the fuel rail is less than 0.2 VDC for 0.6 seconds.

System Response:

If equipped, the diagnostic lamp will come on. The diagnostic code will be logged.

The electronic service tool will display "70000 kPa" next to "Desired Fuel Rail Pressure" and "Actual Fuel Rail Pressure" on the status screens.

Possible Performance Effect:

The engine will be derated.

Troubleshooting:

This diagnostic code detects an excessively low voltage from the fuel rail pressure sensor.

Perform the following diagnostic procedure: "Engine Pressure Sensor Open or Short Circuit - Test"

Results:

- OK – STOP.

i04016609

CID 1834 FMI 02

Conditions Which Generate This Code:

The Electronic Control Module (ECM) detects the following condition:

The signal from the keyswitch was erratic because the power from the keyswitch was cycled at least three times within the last second.

Note: This code can be generated by rapidly cycling the keyswitch. Some control modules on the application may require this action in order to prompt flash codes. If the flash codes appear, clear the logged diagnostic codes in order to prevent future confusion or an incorrect diagnosis.

System Response:

If equipped, the diagnostic lamp will come on. The diagnostic code will be logged. The ECM will stop energizing the injector solenoids.

Possible Performance Effect:

The engine will shut down.

Troubleshooting:

Perform the following diagnostic procedure: "Ignition Keyswitch Circuit and Battery Supply Circuit - Test"

Results:

- OK – STOP.

i04018130

CID 2246 FMI 05

Conditions Which Generate This Code:

The Electronic Control Module (ECM) has detected a low current condition after attempting to activate the glow plug starting aid.

The ECM detects the following conditions:

- The engine is not cranking.
- The ECM has been powered for at least 1 second.
- There is a low current condition for more than 2 seconds.
- No 0168 diagnostic codes are active.

System Response:

If equipped, the diagnostic light will come on. The diagnostic code will be logged. An ECM that was previously blank will require a total of 2 hours of operation before the diagnostic code will be logged.

Possible Performance Effect:

The ECM is unable to activate the positive relay for the glow plug starting aid. The glow plugs will not operate or the glow plugs will operate all the time.

The engine may be difficult to start in cold temperatures and the exhaust may emit white smoke.

Troubleshooting:

This diagnostic code will detect a fault in the circuit for the solenoid in the glow plug relay that is most likely to be an open circuit.

Perform the following diagnostic procedure: "Starting Aid (Glow Plug) Relay Circuit - Test"

Results:

- OK – STOP.

i04016610

CID 2246 FMI 06

Conditions Which Generate This Code:

The Electronic Control Module (ECM) has detected a high current condition (short circuit) after attempting to activate the glow plug starting aid.

The ECM detects the following conditions:

- The engine is not cranking.
- The ECM has been powered for at least 1 second.
- There is a high current condition (short circuit) for more than 2 seconds.

System Response:

If equipped, the diagnostic light will come on. The diagnostic code will be logged. An ECM that was previously blank will require a total of 2 hours of operation before the diagnostic code will be logged.

Possible Performance Effect:

The ECM is unable to activate the relay for the glow plug starting aid. The glow plugs will not operate or the glow plugs will operate all the time.

The engine may be difficult to start in cold temperatures and the exhaust may emit white smoke.

Troubleshooting:

This diagnostic code detects an excessively high current in the circuit for the starting aid relay.

Perform the following diagnostic procedure: "Starting Aid (Glow Plug) Relay Circuit - Test"

Results:

- OK – STOP.

Troubleshooting with an Event Code

i04021987

Event Codes

The ECM can log events. Events refer to engine operating conditions such as low oil pressure or high coolant temperature. Logged events usually indicate a mechanical problem instead of an electronic system problem.

Note: If a diagnostic code has already been logged then any associated event code to that fault will not be logged as well.

Table 21

Trip Points for the Monitoring System								
Condition	Action	Delay Time in Seconds			Trip Point			Default State
		Min	Max	Default	Min	Max	Default	
E360-(1) Low Engine Oil Pressure Warning	Warning	N/A	N/A	30	N/A	N/A	Map dependent value ⁽¹⁾	On
E360-(2) Low Engine Oil Pressure Derate	Derate	N/A	N/A	30	N/A	N/A	Map dependent value ⁽²⁾	On
E361-(1) High Engine Coolant Temperature Warning	Warning	N/A	N/A	30	N/A	N/A	103 °C (217 °F)	On ⁽³⁾
E361-(2) High Engine Coolant Temperature Derate	Derate	N/A	N/A	30	N/A	N/A	111 °C (232 °F)	On
E362-(1) Engine Overspeed Warning	Warning	N/A	N/A	0	N/A	N/A	110% of Engine Speed ⁽⁴⁾	110% of rated engine speed
E539-(1) High Engine Inlet Air Temperature Warning	Warning	N/A	N/A	30	N/A	N/A	70 °C (158 °F)	On ⁽³⁾
E539-(2) High Engine Inlet Air Temperature Derate	Derate	N/A	N/A	30	N/A	N/A	79 °C (174 °F)	Off
E877-(1) High Transmission Oil Temperature Warning	Warning	1	60	10	50 °C (122 °F)	120 °C (248 °F)	95 °C (203 °F)	On
E113-(1) High Transmission Oil Pressure Warning	Warning	0	60	10	689 kPa (100 psi)	3600 kPa (522 psi)	2412 kPa (350 psi)	On
E2143-(1) Low Coolant Level Warning	Warning	4	60	30	N/A	N/A	Low	On
E2143-(2) Low Coolant Level Derate	Derate	4	60	30	N/A	N/A	Low	On
E363-(1) High Fuel Temperature Warning	Warning	N/A	N/A	30	50 °C (122 °F)	80 °C (176 °F)	70 °C (158 °F)	On
E096-(1) High Fuel Pressure Warning	Warning	1	30	2	N/A	N/A	Map dependent value ⁽⁵⁾	On
E198-(1) Low Fuel Pressure Warning	Warning	1	30	2	N/A	N/A	Map dependent value ⁽⁶⁾	On
E119-(1) Low Fuel Level Warning	Warning	60	900	300	5 percent	95 percent	12.5 percent	Off
E194-(1) High Exhaust Temperature Warning	Warning	1	60	30	600° C (1112° F)	850° C (1562° F)	800 °C (1472°F)	On
E232-(1) High Water/Fuel Separator Water Level	Warning	1	60	30	N/A	N/A	Low	On

(1) Refer to Table 22.

(2) Refer to Table 23.

(3) This event is permanently enabled.

(4) Fuel injection is disabled when the engine speed exceeds 110% of rated engine speed. Fuel injection is enabled when the engine speed drops below the high idle engine speed.

(5) Refer to Table 24.

(6) Refer to Table 25.

Table 22

Trip Points for Low Oil Pressure Warning	
0 rpm	0 kPa (0 psi)
500 rpm	0 kPa (0 psi)
1600 rpm	154 kPa (22 psi)
2400 rpm	154 kPa (22 psi)

Table 23

Trip Points for Low Oil Pressure Derate	
0 rpm	0 kPa (0 psi)
500 rpm	0 kPa (0 psi)
1600 rpm	104 kPa (15 psi)
2400 rpm	104 kPa (15 psi)

Table 24

Trip Points for High Fuel Pressure Warning	
500 rpm	759 kPa (110 psi)
2000 rpm	794 kPa (115 psi)

Table 25

Trip Points for Low Fuel Pressure Warning	
500 rpm	350 kPa (51 psi)
700 rpm	380 kPa (55 psi)
980 rpm	390 kPa (57 psi)
1100 rpm	400 kPa (58 psi)
2300 rpm	400 kPa (58 psi)
2600 rpm	410 kPa (59 psi)

i04018129

E096 High Fuel Pressure

Conditions Which Generate This Code:

This event code will only be generated if the sensor for high fuel pressure is installed and correctly wired to the ECM. The feature must be enabled in the customer programmable parameters on the electronic service tool.

The Electronic Control Module (ECM) detects a high fuel pressure. Information on default settings and ranges for these event codes can be found in troubleshooting with an event code Troubleshooting, "Event Codes".

System Response:

The ECM will log the code.

Possible Performance Effect:

Engine performance is not affected.

Check the Low Pressure Fuel System

Check the components of the low-pressure fuel system.

Check the pressure of the low-pressure fuel system.

Expected Result:

There is a problem with the low-pressure fuel system.

Results:

- OK – There is a problem with the low-pressure fuel system.

Repair: Make the necessary repairs. Verify that the repair eliminates the problem.

STOP.

i04022059

E113 High Transmission Oil Pressure

Conditions Which Generate This Code:

This event code will only be generated if the sensor for the transmission oil temperature is installed and correctly wired to the ECM. The feature must be enabled in the customer programmable parameters on the electronic service tool.

The transmission oil pressure has exceeded the trip point. Refer to Troubleshooting, "Event Codes" for the trip point.

System Response:

The Electronic Control Module (ECM) will log the event.

Possible Performance Effect:

- There are no performance effects.

Troubleshooting:

Check the Transmission

Refer to the information that is provided by the OEM for the transmission.

Results:

- OK – There is a problem with the transmission.

Repair: Make the necessary repairs. Verify that the problem is resolved.

STOP.

i04018233

E119 Low Fuel Level

Conditions Which Generate This Code:

This event code will only be generated if the sensor for the fuel level is installed and correctly wired to the ECM. The feature must be enabled in the customer programmable parameters on the electronic service tool.

The fuel level is below the trip point. Refer to Troubleshooting, “Event Codes” for the trip points.

System Response:

The Electronic Control Module (ECM) will log the event.

Possible Performance Effect:

- There are no performance effects.

Troubleshooting:

Add fuel to the fuel tank. Refer to the literature that is provided by the OEM of the vessel for the correct procedure.

Results:

- OK – STOP.

i04018234

E179 Alternator Not Charging

Conditions Which Generate This Code:

The Electronic Control Module (ECM) detects that the alternator is not charging the batteries. Information on default settings and ranges for these event codes can be found in troubleshooting with an event code Troubleshooting, “Event Codes”.

System Response:

The Electronic Control Module (ECM) will log the code.

Possible Performance Effect:

- There are no performance effects.

Troubleshooting:

Check the Alternator Relay

Check the relay attached to the alternator which is driven by the alternator output voltage.

Expected Result:

The alternator is not driving the relay.

Results:

- OK – The alternator is driving the relay.

Repair: Make the necessary repairs. Verify that the repair eliminates the problem.

STOP.

i04016611

E194 High Exhaust Temperature

Conditions Which Generate This Code:

This event code will only be generated if the sensor for the exhaust gas temperature is installed and correctly wired to the ECM. The feature must be enabled in the customer programmable parameters on the electronic service tool.

The exhaust gas temperature has exceeded the trip point. Refer to Troubleshooting, “Event Codes” for the trip point.

System Response:

If equipped, the warning lamp may come on and the event code will be logged.

Possible Performance Effect:

None

Test Step 1. Determine the Operating Conditions

Determine if the engine was under heavy load or the engine is operating at a high altitude.

Expected Result:

The event occurred because of abnormal engine operation.

Results:

- OK – The event occurred because of abnormal engine operation. Clear the logged event and return the engine to service at a reduced load. STOP.
- Not OK – The event indicates an engine fault. If the engine is equipped with an air-to-air aftercooler, proceed to Test Step 2.

Test Step 2. Check the Air-to-Air Aftercooler (ATAAC) (if equipped)

The intake manifold air temperature can increase if the ATAAC is obstructed. Check the fins of the ATAAC for obstructions.

Expected Result:

The fins of the ATAAC are obstructed.

Results:

- OK – The fins of the ATAAC are obstructed.

Repair: Clean the fins of the ATAAC. Clear the event. Refer to the OEM manual for the ATAAC. Return the engine to service.

STOP.

- Not OK – The fins of the ATAAC are clear of obstructions.

STOP.

i04018157

E198 Low Fuel Pressure

Conditions Which Generate This Code:

This event code will only be generated if the sensor for low fuel pressure is installed and correctly wired to the ECM. The feature must be enabled in the customer programmable parameters on the electronic service tool.

The Electronic Control Module (ECM) detects a low fuel pressure. Information on default settings and ranges for these event codes can be found in troubleshooting with an event code Troubleshooting, "Event Codes".

System Response:

The ECM will log the code.

Possible Performance Effect:

Engine performance is not affected.

Check the Low Pressure Fuel System

Check the components of the low-pressure fuel system.

Check the pressure of the low-pressure fuel system.

Expected Result:

There is a problem with the low-pressure fuel system.

Results:

- OK – There is a problem with the low-pressure fuel system.

Repair: Make the necessary repairs. Verify that the repair eliminates the problem.

STOP.

i04053289

E232 High Fuel/Water Separator Water Level

Conditions Which Generate This Code:

This event code will only be generated if the switch on the water separator filter is installed and correctly wired to the ECM. The feature must be enabled in the customer programmable parameters on the electronic service tool.

The Electronic Control Module (ECM) detects a high water level in the fuel filter. If the water rises above a set level for more than thirty seconds, the ECM will generate this event code. The code will become inactive when the switch has been immersed in fuel for 5 seconds.

Note: The code is generated only when the engine is running.

System Response:

If equipped, the warning lamp will come on and the event code will be logged.

Possible Performance Effect:

E232-1

None

Troubleshooting:

Refer to Systems Operation, Testing and Adjusting manual, "Fuel System - Inspect".

Results:

- OK – STOP.

i04018270

E268 Unexpected Engine Shutdown

Conditions Which Generate This Code:

The Electronic Control Module (ECM) detects an unexpected engine shutdown under the following conditions:

- Engine is running
- Remote shutdown switch is inactive (if equipped)
- System shutdown is inactive
- The ECM has detected zero engine speed. Refer to Troubleshooting, "Event Codes" for the trip point.

System Response:

The Electronic Control Module (ECM) will log the event.

Possible Performance Effect:

- None.

Troubleshooting:

Check the Engine System

Check the air and fuel system. Verify that there are no blockages.

Expected Result:

A thorough inspection of the system has revealed a problem.

Results:

- OK – There is a problem with the fuel system.

Repair: Make the necessary repairs. Verify that the problem is resolved.

STOP.

- Not OK – There is a problem with the air intake system.

Repair: Repair the problem. Ensure that the repair eliminates the problem.

STOP.

i04012509

E360 Low Engine Oil Pressure

Conditions Which Generate This Code:

The engine oil pressure has exceeded the trip point. Refer to Troubleshooting, "Event Codes" for the trip point.

System Response:

360-1

The diagnostic lamp will flash while the event code is active.

The Electronic Control Module (ECM) will generate a 157 flash code that will be displayed via the diagnostic lamp.

The ECM will generate a E360-1 event code.

The ECM will generate a SPN 100-FMI 17 event code on the J1939 data link. The event code may be displayed on a receiving device on the J1939 data link.

The warning will be canceled if the oil pressure rises 21 kPa (3 psi) above the set point for 20 seconds.

360-2

The diagnostic lamp will flash while the event code is active.

The ECM will generate a 157 flash code that will be displayed via the diagnostic lamp.

The ECM will generate a E360-2 event code.

The electronic service tool will display "Engine Derate" in the first "Engine Status" box on any status screen.

The ECM will generate a SPN 100-FMI 18 event code on the J1939 data link. The event code may be displayed on a receiving device on the J1939 data link.

The derate will be canceled if the oil pressure rises 21 kPa (3 psi) above the set point for 20 seconds.

Possible Performance Effect:

360-1

Engine operation is not affected.

360-2

The ECM will derate power by 17.0 percent per second up to a maximum of 100 percent while the derate is active.

Troubleshooting:

Refer to Troubleshooting, "Low Engine Oil Pressure".

Results:

- OK – STOP.

i04012513

E361 High Engine Coolant Temperature

Conditions Which Generate This Code:

The Electronic Control Module (ECM) detects a high engine coolant temperature under the following conditions:

- The engine has been running for more than 185 seconds.
- The trip point for the event code for the temperature of the engine coolant is reached.
- Diagnostic code 0110-03 Engine Coolant Temperature voltage above normal is not active.
- Diagnostic code 0110-04 Engine Coolant Temperature voltage below normal is not active.
- Diagnostic code 0168-01 Electrical System voltage low is not active.

Table 26

Trip Points for the Engine Coolant Temperature		
	E361-1	E361-2
Trip Point	103° C (217° F)	111° C (232° F)
Delay to Activation	30 seconds	30 seconds
Reset Time	5 seconds	5 seconds

System Response:

If equipped, the diagnostic lamp will come on and the event code will be logged.

Possible Performance Effect:

E361-1

None

i04018249

E361-2

The ECM will derate the power at 1 percent per second.

Troubleshooting:

Refer to Troubleshooting, "Coolant Temperature Is Too High".

Results:

- OK – STOP.

i04012512

E362 Engine Overspeed**Conditions Which Generate This Code:**

The engine speed is above 2840 RPM for more than 0.6 seconds.

Note: This event code represents an event. This does not represent an electronic system fault.

System Response:

If equipped, the diagnostic lamp will come on and the event code will be logged.

The ECM will reset the event when the engine speed is lower than 2640 RPM for 0.6 seconds.

Possible Performance Effect:**E362-1**

The fuel injection will be disabled until the event has been reset.

Troubleshooting:

This event indicates excessive engine speed. This event does not represent a fault in the Engine Control Module (ECM).

This event does not represent a fault in the Electronic Speed/Timing Sensor.

No troubleshooting is required.

Results:

- OK – STOP.

E363 High Fuel Supply Temperature**Conditions Which Generate This Code:**

This event code will only be generated if the switch for the fuel temperature is installed and correctly wired to the ECM. The feature must be enabled in the customer programmable parameters on the electronic service tool.

The fuel temperature has exceeded the trip point. Refer to Troubleshooting, "Event Codes" for the trip point.

System Response:

The Electronic Control Module (ECM) will log the event.

Possible Performance Effect:

- There are no performance effects.

Troubleshooting:**Check the Fuel System**

A. Check the heat exchanger (if equipped). Verify that the heat exchanger is free of debris and of obstructions.

Expected Result:

A thorough inspection of the heat exchanger revealed a problem.

Results:

- OK – There is a problem with the heat exchanger.

Repair: Make the necessary repairs. Verify that the repair eliminates the problem.

STOP.

- Not OK – There is a problem with the fuel system.

Repair: Repair the problem.

Ensure that the repair eliminates the problem.

STOP.

i04016612

i04016613

E396 High Fuel Rail Pressure

Conditions Which Generate This Code:

The Electronic Control Module (ECM) detects excessive fuel rail pressure under the following conditions:

- The ECM detects fuel rail pressure that is more than the pressure that is required for the operating conditions.
- Diagnostic code 0262-03 5 V Sensor DC Power Supply voltage above normal is not active.
- Diagnostic code 0262-04 5 V Sensor DC Power Supply voltage below normal is not active.
- Diagnostic code 1797-03 Fuel Rail Pressure Sensor voltage above normal is not active.
- Diagnostic code 1797-04 Fuel Rail Pressure Sensor voltage below normal is not active.
- No diagnostic codes are active for the fuel rail pump.
- No diagnostic codes are active for the fuel injectors.

System Response:

If equipped, the diagnostic lamp will come on and the event code will be logged.

The engine will derate to 100 percent.

Possible Performance Effect:

The engine will be derated until the keyswitch is turned to OFF and then turned to ON.

Troubleshooting:

The event code does not represent a fault in the electronic system. This event indicates high fuel pressure.

A failed relief valve, the fuel pump, or an electronic unit injector may cause the event code to appear.

Results:

- OK – STOP.

E398 Low Fuel Rail Pressure

Conditions Which Generate This Code:

The Electronic Control Module (ECM) detects low fuel rail pressure under the following conditions:

- The ECM determines that the expected fuel rail pressure is lower than the pressure that is requested by the electronic control system.
- Diagnostic code 0262-03 5 V Sensor DC Power Supply voltage above normal is not active.
- Diagnostic code 0262-04 5 V Sensor DC Power Supply voltage below normal is not active.
- Diagnostic code 1797-03 Fuel Rail Pressure Sensor voltage above normal is not active.
- Diagnostic code 1797-04 Fuel Rail Pressure Sensor voltage below normal is not active.
- No diagnostic codes are active for the fuel rail pump.
- No diagnostic codes are active for the fuel injectors.

System Response:

If equipped, the diagnostic lamp will come on and the event code will be logged.

The engine will derate to 100 percent.

Possible Performance Effect:

The engine will be derated until the keyswitch is turned to OFF and then turned to ON.

Troubleshooting:

Low fuel pressure may be caused by the following problems:

- A fault in the fuel return system
- A fault in the fuel pressure control
- A leak in the high-pressure fuel system
- A failed relief valve, the fuel pump, or an electronic unit injector

The event code does not represent a fault in the electronic system.

Results:

- OK – STOP.

i04012516

E539 High Intake Manifold Air Temperature

Conditions Which Generate This Code:

The Electronic Control Module (ECM) detects a high air temperature in the intake manifold under the following conditions:

- The engine has been running for more than 3 minutes.
- The temperature of the coolant is more than 99 °C (210 °F) and the intake manifold pressure is more than 30 kPa (4.35 psi).
- The trip level for the intake manifold air temperature is reached.
- Diagnostic code 0172-03 Intake Manifold Air Temperature voltage above normal is not active.
- Diagnostic code 0172-04 Intake Manifold Air Temperature voltage below normal is not active.

Table 27

Intake Manifold Air Temperature Trip Level Table		
	E539-1	E539-2
Turbocharged Engines (T)	139 °C (282 °F)	142 °C (287 °F)
Turbocharged Aftercooled Engines (TA)	70° C (158° F)	79° C (174° F)
Delay to Activation	30 seconds	30 seconds
Reset Time	5 seconds	5 seconds

System Response:

If equipped, the warning lamp will come on and the event code will be logged.

Possible Performance Effect:**E539-1**

None

E539-2

The ECM will derate the power at 1 percent per second.

Troubleshooting:

Refer to Troubleshooting, "Intake Air Temperature Is Too High".

Results:

- OK – STOP.

i04018251

E877 High Transmission Oil Temperature

Conditions Which Generate This Code:

The transmission oil temperature has exceeded the trip point. Refer to Troubleshooting, "Event Codes" for the trip point.

System Response:

The Electronic Control Module (ECM) will log the event.

Possible Performance Effect:

- There are no performance effects.

Troubleshooting:

Check the Transmission

Refer to the information that is provided by the OEM for the transmission.

Results:

- OK – There is a problem with the transmission.

Repair: Make the necessary repairs. Verify that the problem is resolved.

STOP.

System Response:

The Electronic Control Module (ECM) will log the event.

Possible Performance Effect:

- The engine will derate to 20 percent and key cycle is required to clear the engine derate.

Troubleshooting:

Check the Air System

Check the air intake system. Verify that the air intake system is free of debris and of obstructions.

Expected Result:

A thorough inspection of the air intake system revealed a problem.

Results:

- OK – There is a problem with the air intake system.

Repair: Make the necessary repairs. Verify that the problem is resolved.

STOP.

- Not OK – There is a problem with the air intake system.

Repair: Repair the problem. Ensure that the repair eliminates the problem.

STOP.

i04018252

E1044 High Intake Manifold Pressure

Conditions Which Generate This Code:

The Electronic Control Module (ECM) detects a high intake manifold pressure under the following conditions:

- Engine speed is greater than 1300 rpm and running for 180 seconds
- Coolant temperature is greater than 70° C (158° F)
- Desired boost pressure is greater than 100 kPa (14.5 psi)
- The intake manifold pressure has exceeded the trip point. Refer to Troubleshooting, "Event Codes" for the trip point.

i04018269

E1045 Low Intake Manifold Pressure

Conditions Which Generate This Code:

The Electronic Control Module (ECM) detects a low intake manifold pressure under the following conditions:

- Engine speed is greater than 1300 rpm and running for 180 seconds
- Coolant temperature is greater than 70° C (158° F)
- Desired boost pressure is greater than 100 kPa (14.5 psi)

- The intake manifold pressure has exceeded the trip point. Refer to Troubleshooting, “Event Codes” for the trip point.

The ECM detects a low coolant level in the engine for more than 30 seconds.

System Response:

The Electronic Control Module (ECM) will log the event.

Possible Performance Effect:

- The engine will derate to 100 percent and key cycle is required to clear the engine derate.

Troubleshooting:**Check the Air System**

Check the air intake system. Verify that the wastegate solenoid is working OK.

Expected Result:

A thorough inspection of the wastegate solenoid has revealed a problem.

Results:

- OK – There is a problem with the wastegate solenoid.

Repair: Make the necessary repairs. Verify that the problem is resolved.

STOP.

- Not OK – There is a problem with the air intake system.

Repair: Repair the problem. Ensure that the repair eliminates the problem.

STOP.

i04012529

E2143 Low Engine Coolant Level

Conditions Which Generate This Code:

This event code will only be generated if the switch for the engine coolant level is installed and correctly wired to the ECM. The feature must be enabled in the customer programmable parameters on the electronic service tool.

Note: This event code will only be generated if a coolant level sensor is installed and the customer programmable feature has been enabled.

Table 28

Low Engine Coolant Level Table		
	E2143-1	E2143-2
Trip Point	Low	Low
Delay to Activation	30 seconds	30 seconds
Reset Time	30 seconds	30 seconds

System Response:

If equipped, the shutdown lamp and the warning lamp will come on.

The event code will be logged.

Possible Performance Effect:

E2143-1

None

E2143-2

The engine will derate to 100 percent.

Troubleshooting:

The event code may represent a fault in the electronic system. This event normally indicates low engine coolant. Refer to Systems Operation, Testing and Adjusting Manual, "Cooling System - Inspect".

Results:

- OK – STOP.

Diagnostic Functional Tests

- A suspect sensor
- A suspect ECM

i04012485

5 Volt Sensor Supply Circuit - Test

System Operation Description:

Use this procedure to troubleshoot the system when one of the following diagnostic codes is active or easily repeated:

- 0262-03 5 Volt Sensor DC Power Supply voltage above normal
- 0262-04 5 Volt Sensor DC Power Supply voltage below normal

Also, use this procedure to troubleshoot the system when you have been directed here by another troubleshooting procedure.

The following background information is related to this procedure:

The Engine Control Module (ECM) supplies regulated +5 VDC to the following sensors:

- Fuel Rail Pressure Sensor through connector A-C6
- Intake Manifold Pressure Sensor through connector A-C7
- Engine Oil Pressure Sensor through connector A-C5
- Fuel Pressure Sensor through connector A-C14
- Transmission Oil Pressure Sensor through connector A-C18
- Exhaust Gas Temperature Sensor through connector E-C7

The supply for the +5 V engine pressure sensor is routed from the ECM through the A-C1 connector to terminal 1 of each pressure sensor connector. The supply voltage is 5.0 ± 0.16 VDC.

The +5 V diagnostic code is probably caused by a short circuit to ground or a short circuit to another voltage source in the harness.

A diagnostic code can be caused by the following conditions:

- A short circuit in the harness

Table 29

P1 Pin Connections			
Sensor Pin	Function	Fuel Pressure Sensor	Exhaust Gas Temperature Sensor
1	Volts (5 V)	41	42
2	Ground	33	34
3	Signal	56	54

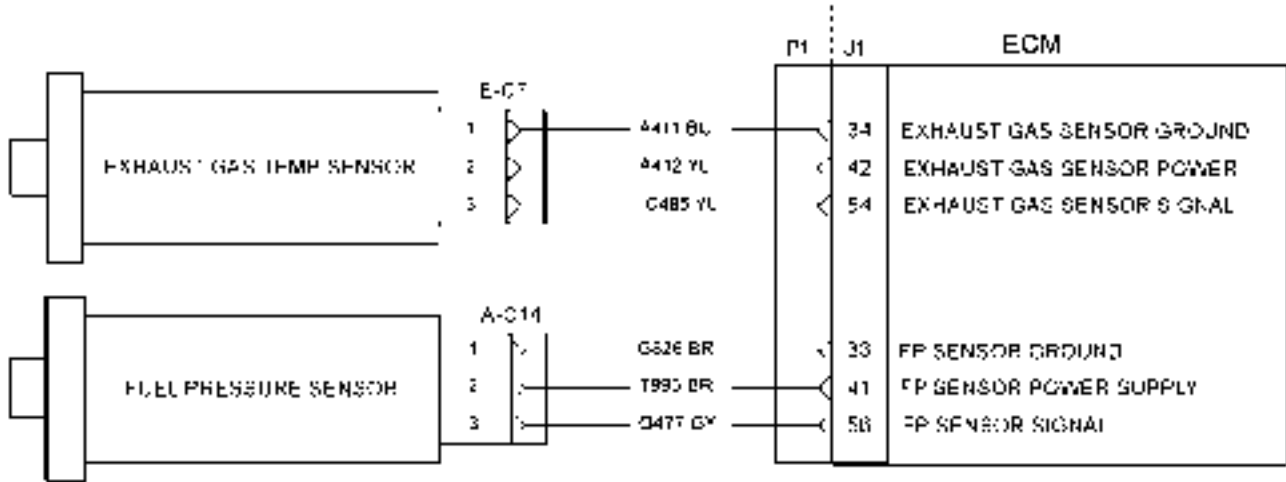

Illustration 15
Typical example

g02199234

Table 30

P2 Pin Connections					
Sensor Pin	Function	Fuel Rail Pressure Sensor	Intake Manifold Pressure Sensor	Oil Pressure Sensor	Transmission Oil Pressure Sensor
1	Volts (5 V)	48	46	46	47
2	Ground	40	38	39	44
3	Signal	51	55	56	54

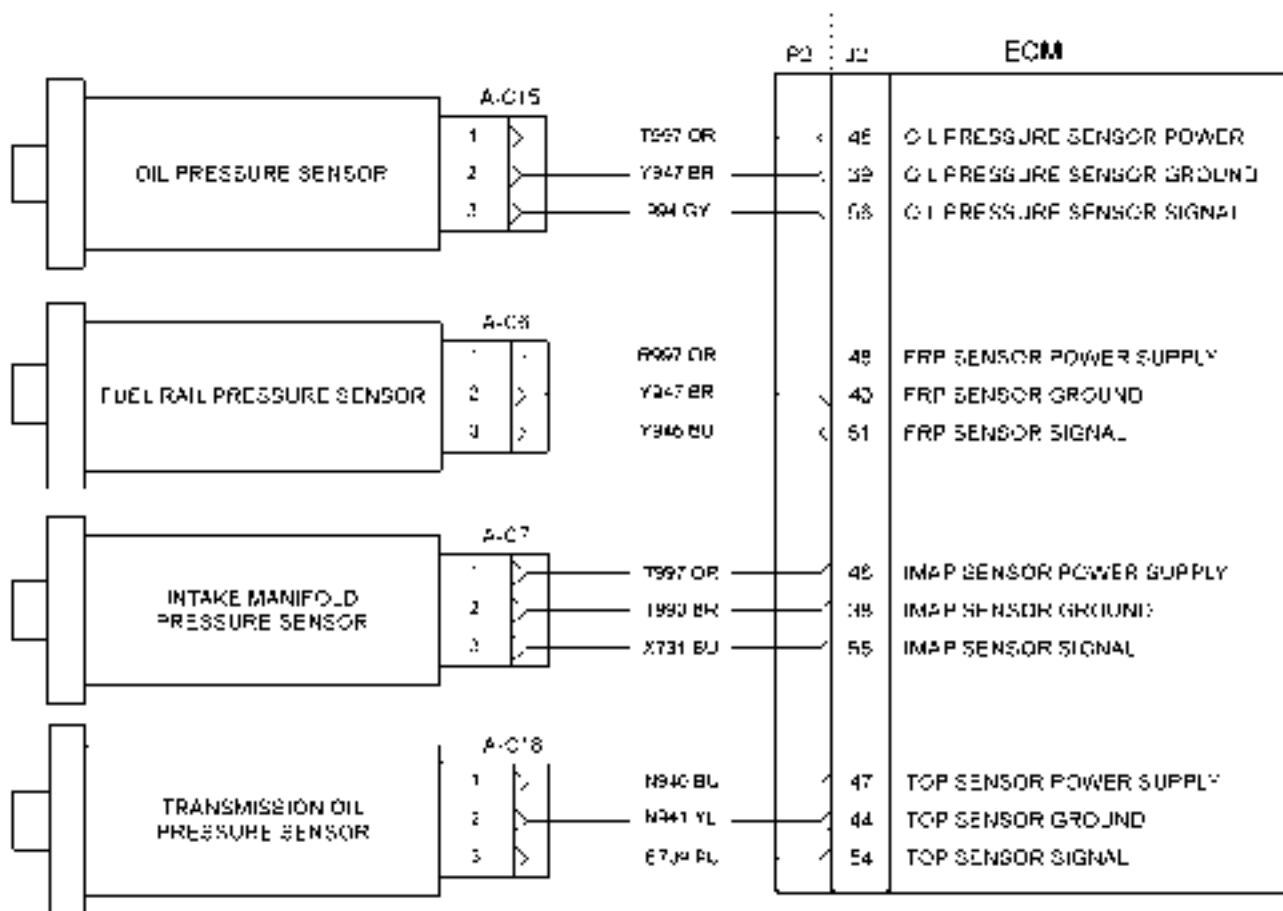

Illustration 16
Typical example

g02193216

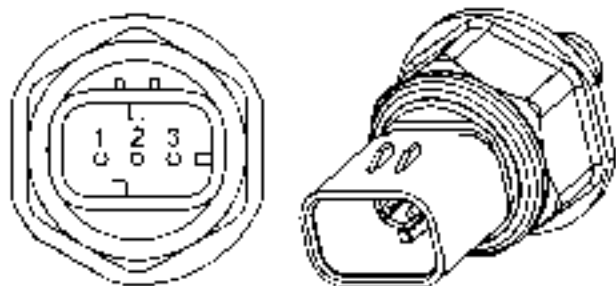

Illustration 17
Typical example of the fuel rail pressure sensor

- (1) Voltage supply (Vs)
- (2) Ground (GND)
- (3) Signal (SIG)

g01173224

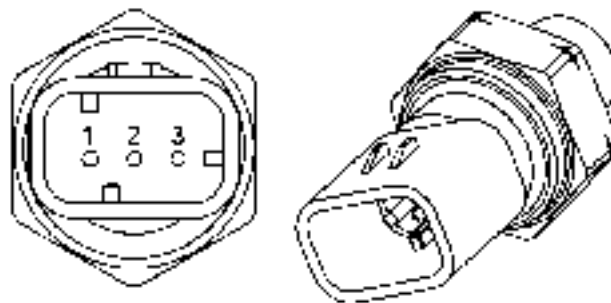

Illustration 18
Typical example of the intake manifold pressure sensor

- (1) Voltage Supply (Vs)
- (2) Ground (GND)
- (3) Signal (SIG)

g01173225

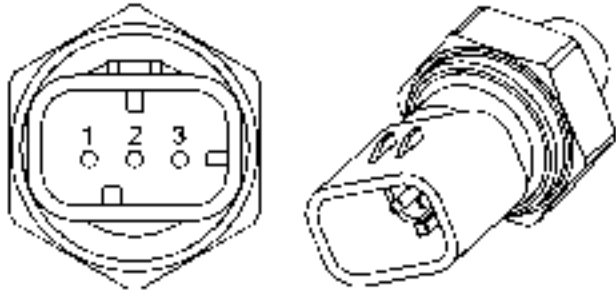

Illustration 19 g01173226

Typical example of the oil pressure sensor

- (1) Voltage Supply (Vs)
- (2) Ground (GND)
- (3) Signal (SIG)

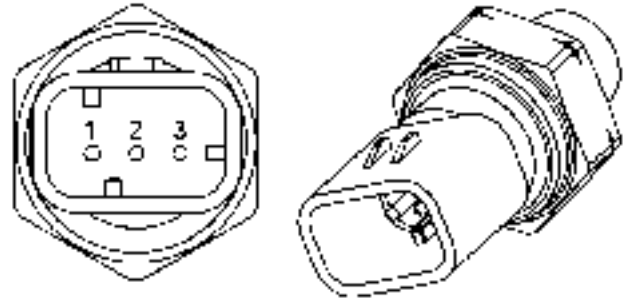

Illustration 22 g01173225

Typical example of the exhaust gas temperature sensor

- (1) Voltage Supply (Vs)
- (2) Ground (GND)
- (3) Signal (SIG)

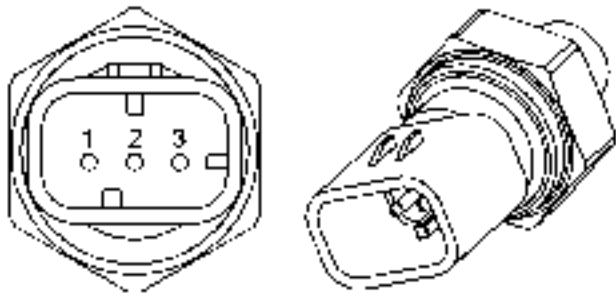

Illustration 20 g01173226

Typical example of the transmission oil pressure sensor

- (1) Voltage Supply (Vs)
- (2) Ground (GND)
- (3) Signal (SIG)

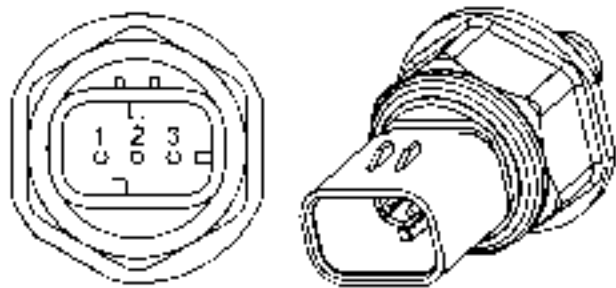

Illustration 21 g01173224

Typical example of the fuel pressure sensor

- (1) Voltage supply (Vs)
- (2) Ground (GND)
- (3) Signal (SIG)

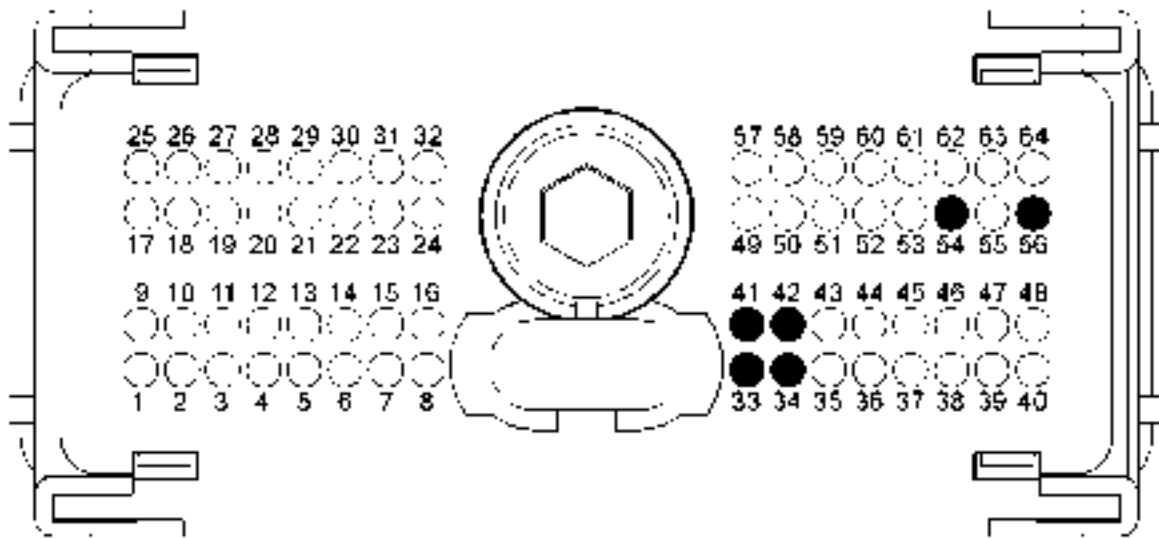

Illustration 23

g02199236

Typical example of the P1 pressure sensor pin locations

- | | | |
|--|--|--|
| (33) Voltage supply (5 V) Fuel Pressure Sensor | (41) Ground (GND) Fuel Pressure Sensor | (54) Signal (SIG) Exhaust Gas Temperature Sensor |
| (34) Voltage supply (5 V) Exhaust Gas Temperature Sensor | (42) Ground (GND) Exhaust Gas Temperature Sensor | (56) Signal (SIG) Fuel Pressure Sensor |

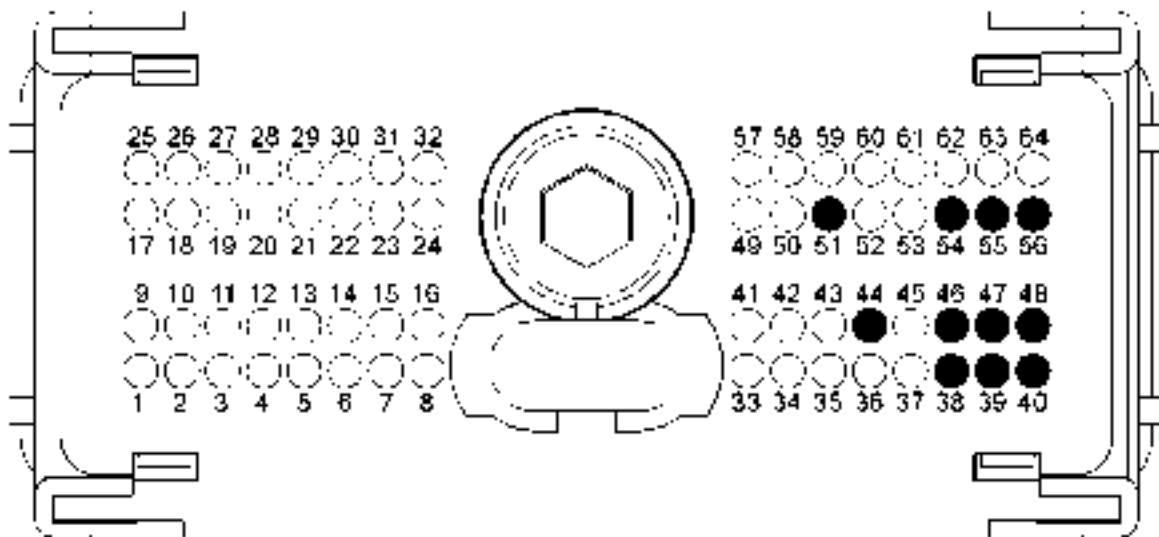

Illustration 24

g02193219

Typical example of the P2 pressure sensor pin locations

- | | | |
|--|---|--|
| (38) Ground (GND) Intake Manifold Pressure Sensor | (46) Voltage supply (5 V) Intake Manifold Pressure Sensor and Oil Pressure Sensor | (51) Signal (SIG) Fuel Rail Pressure Sensor |
| (39) Ground (GND) Oil Pressure Sensor | (47) Voltage supply (5 V) Transmission Oil Pressure Sensor | (54) Signal (SIG) Transmission Oil Pressure Sensor |
| (40) Ground (GND) Fuel Rail Pressure Sensor | (48) Voltage supply (5 V) Fuel Rail Pressure Sensor | (55) Signal (SIG) Intake Manifold Pressure Sensor |
| (44) Ground (GND) Transmission Oil Pressure Sensor | | (56) Signal (SIG) Oil Pressure Sensor |

Test Step 1. Check for Connector Damage

A. Turn the keyswitch to the OFF position.

B. Check the connectors and the harness for the following faults:

- Damage

- Abrasion
- Corrosion
- Incorrect attachment

C. Refer to Troubleshooting, "Electrical Connectors - Inspect".

D. Perform a 45 N (10 lb) pull test on each of the wires in the harness that are associated with the throttle demand sensor. Check the wire connectors at the following positions:

- ECM
- Pressure sensors
- Throttle pedal

The wire connectors are shown in table 30.

E. Check the screws for the ECM connectors for the correct torque of 5.0 N·m (44 lb in).

Expected Result:

The connectors and the harness should be free of the following faults: damage, abrasion, corrosion, and incorrect attachment.

Results:

- OK – Proceed to Test Step 2.
- Not OK

Repair: Repair the connectors or the harness and/or replace the connectors or the harness.

Use the electronic service tool in order to clear all logged diagnostic codes and then verify that the repair eliminates the fault.

STOP.

Test Step 2. Check for Active Diagnostic Codes

- A.** Connect the electronic service tool to the diagnostic connector.
- B.** Turn the keyswitch to the ON position.
- C.** Use the electronic service tool in order to monitor the diagnostic codes. Check and record any active diagnostic codes.

Note: Wait at least 15 seconds in order for the diagnostic codes to become active.

Expected Result:

One of the following diagnostic codes is active:

- 0262-03 5 Volt Sensor DC Power Supply voltage above normal
- 0262-04 5 Volt Sensor DC Power Supply voltage below normal

Results:

- OK – Diagnostic code 0262-04 is active. Proceed to Test Step 3.
- OK – Diagnostic code 0262-03 is active. Proceed to Test Step 6.
- Not OK – Diagnostic codes 0262-04 and 0262-03 are not active. Proceed to Test Step 4.

Test Step 3. Disconnect the Sensors

- A.** Turn the keyswitch to the ON position.
- B.** Use the electronic service tool in order to monitor the diagnostic codes.
- C.** Disconnect the pressure sensors and the exhaust gas temperature sensor one at a time. Wait for 30 seconds after each of the sensors is disconnected.

Note: Diagnostic code 0262-04 will become inactive when the sensor that caused the 5 V diagnostic code is disconnected.

D. Ensure that all the pressure sensors and the exhaust gas temperature sensor are disconnected.

Expected Result:

The 5 V diagnostic code is not active when all of the sensors are disconnected.

Results:

- OK – The 5 V diagnostic code is not active when all of the sensors are disconnected.

Repair: Reconnect all of the sensors except the suspect sensor.

Proceed to Test Step 4.

- Not OK – Diagnostic code 0262-04 is still active.

Repair: Leave all of the sensors disconnected.

Proceed to Test Step 5.

Test Step 4. Install a New Sensor

- A. Remove the connector from the suspect sensor and connect the connector to a replacement sensor. Do not install the replacement sensor to the engine.
- B. Use the electronic service tool in order to monitor the diagnostic codes.

Expected Result:

Diagnostic codes 0262-03 and 0262-04 are not active.

Results:

- OK – The 5 V diagnostic code is not active.

Repair: Use the electronic service tool in order to clear all logged diagnostic codes. Remove the suspect sensor and then install the replacement sensor. Connect the connector to the sensor.

Verify that the repair eliminates the fault.

STOP.

- Not OK – The 5 V diagnostic code is still active.

Repair: Do not use the new sensor.

Proceed to Test Step 5.

Test Step 5. Disconnect the ECM Connector and Check for Active Diagnostic Codes

- A. Turn the keyswitch to the OFF position.
- B. Connect the electronic service tool to the diagnostic connector.
- C. Check the ECM connectors for corrosion and moisture.
- D. Disconnect the P2 ECM connector from the ECM.
- E. If a P1:41 is installed, then temporarily disconnect the pin. If a P1:42 is installed, then temporarily disconnect the pin.
- F. Reconnect the P1 connector to the ECM.
- G. Turn the keyswitch to the ON position.
- H. Check for active diagnostic codes on the electronic service tool.

Note: A “voltage high” diagnostic code (open circuit) should be active for all of the following sensors:

- Engine pressure sensors

- Engine temperature sensors

Expected Result:

Diagnostic code 0262-04 is not active. A “voltage high” diagnostic code (open circuit) is active for all of the engine pressure sensors and temperature sensors.

Results:

- OK – Diagnostic code 0262-04 is not active.

Repair: Replace all wires to the original configuration.

Proceed to Test Step 6.

- Not OK – The 5 V diagnostic code is still active.

Repair: Perform the following repair:

1. Make sure that the latest flash file for the application is installed in the ECM. Refer to Troubleshooting, “Flash Programming”.
2. Contact the Technical Help Desk.

Note: This consultation can greatly reduce the repair time.

3. If the Technical Help Desk recommends the use of a test ECM, install a test ECM. Refer to Troubleshooting, “Replacing the ECM”.
4. Use the electronic service tool to recheck the system for active diagnostic codes.
5. If the fault is resolved with the test ECM, reconnect the suspect ECM.
6. If the fault returns with the suspect ECM, replace the ECM.
7. Use the electronic service tool in order to clear all logged diagnostic codes and then verify that the repair eliminates the fault.

STOP.

Test Step 6. Measure the +5 Volt Supply to the Sensor

- A. Turn the keyswitch to the ON position.

Note: All the pressure sensors should be disconnected.

- B. Measure the voltage between terminal 1 (Pressure sensor +5 Volts) and the engine ground for each of the pressure sensors.

Expected Result:

The voltage is 5.0 ± 0.16 VDC.

Results:

- OK – The +5 V supply is within the expected range. Proceed to Test Step 7.
- Not OK – The voltage is greater than 5.16 VDC.

Repair: Check the +5 V supply wire for a short to a higher voltage source.

Repair the +5 V supply wire and/or replace the +5 V supply wire.

Verify that the repair eliminates the fault.

STOP.

- Not OK – The voltage is less than 4.84 VDC.

Repair: Check the +5 V supply wire for a short to ground.

Repair the +5 V supply wire and/or replace the +5 V supply wire.

Use the electronic service tool in order to clear all logged diagnostic codes and then verify that the repair eliminates the fault.

STOP.

Test Step 7. Perform the “Wiggle Test” on the Electronic Service Tool

- Select the “Wiggle Test” from the diagnostic tests on the electronic service tool.
- Choose the appropriate group of parameters to monitor.
- Press the “Start” button. Wiggle the wiring harness in order to reproduce intermittent faults.

If an intermittent fault exists, the status will be highlighted and an audible beep will be heard.

Expected Result:

No intermittent faults were indicated during the “Wiggle Test”.

Results:

- OK – No intermittent faults were found. The harness and connectors appear to be OK. If you were sent from another procedure, return to the procedure and continue testing. If this test has resolved the fault, return the engine to service. STOP.

- Not OK – At least one intermittent fault was indicated.

Repair: Repair the harness or the connector.

Use the electronic service tool in order to clear all logged diagnostic codes and then verify that the repair eliminates the fault.

STOP.

i04010970

CAN Data Link Circuit - Test

System Operation Description:

The CAN data link is used to communicate information between the Electronic Control Module (ECM) and other modules. Use this procedure to troubleshoot any suspect problems with the CAN data link.

This procedure identifies the following problems:

- Faulty connectors
- Missing termination resistors
- Short circuits
- Open circuits
- Faulty marine power display

A problem with the CAN data link is probably caused by a short circuit to ground or a short circuit to another voltage source in the harness. The next likely cause is a problem with a module that is connected to the data link. The least likely cause is a problem with the ECM.

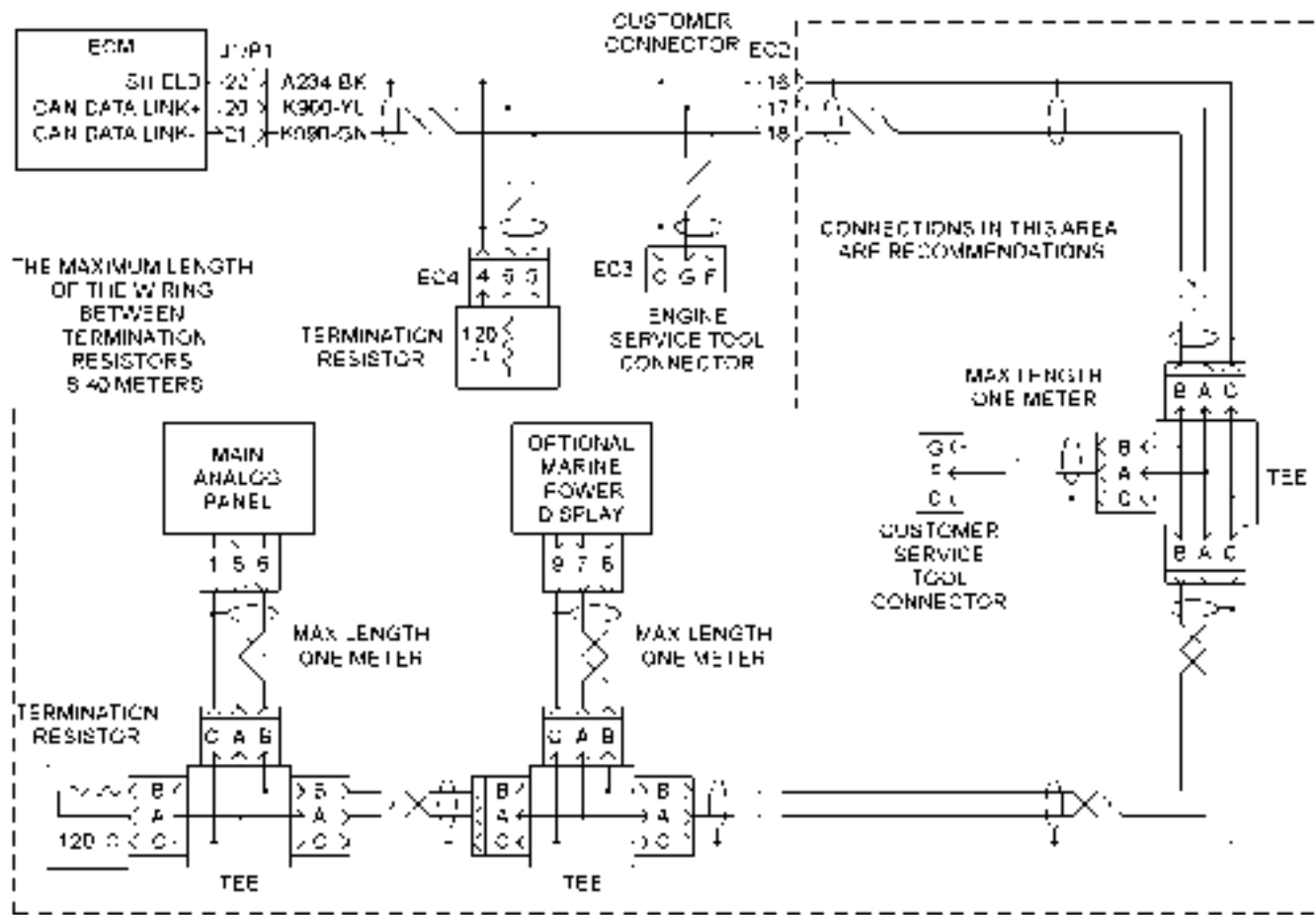

Illustration 25
Schematic for the CAN data link

g02193373

Test Step 1. Inspect the Electrical Connectors and the Wiring

- A. Remove the electrical power from the ECM.
- B. Thoroughly inspect connectors for the ECM, electronic service tool and the customer.

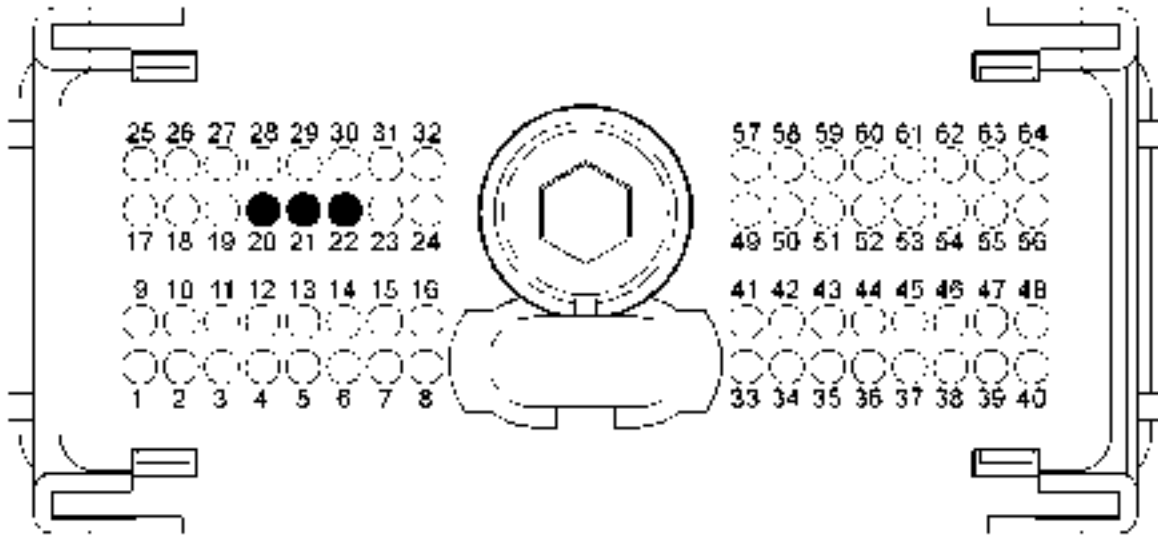

Illustration 26

g02193395

P1 terminals that are associated with the CAN data link

(21) CAN data link -

(22) CAN shield

(20) CAN data link +

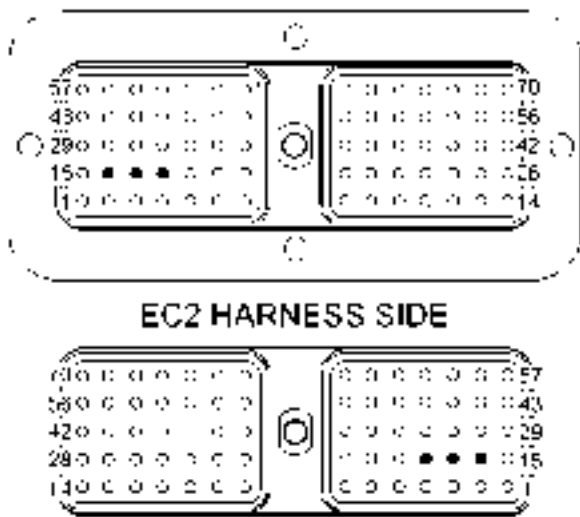

EC2 HARNESS SIDE

Illustration 27

g02199317

Terminals that are associated with the CAN data link

(16) Shield

(17) CAN data link +

(18) CAN data link -

C. Perform a 45 N (10 lb) pull test on each of the wires that are associated with the CAN data link.

D. Check the allen head screw on each ECM connector and on the customer connector for the proper torque. Refer to the diagnostic functional test Troubleshooting, "Electrical Connectors - Inspect".

E. Check the wiring harnesses for abrasion, for corrosion and for pinch points.

Expected Result:

All connectors, pins and sockets are completely coupled and/or inserted. The harness and wiring are free of corrosion, of abrasion and of pinch points.

Results:

- OK – The harness and wiring appear to be OK. Proceed to Test Step 2.
- Not OK – There is a problem in the wiring harness.

Repair: Repair the connectors and/or the wiring. Replace parts, if necessary. Ensure that all of the seals are properly in place and ensure that the connectors are completely coupled. Verify that the problem is resolved.

STOP.

Test Step 2. Verify the Proper Installation of the Termination Resistors

- A.** Remove the electrical power from the ECM.
- B.** Disconnect the Mini Marine Power Display (MMPD).
- C.** Disconnect any other display that is connected to the CAN data link.
- D.** Disconnect the electronic service tool from the service tool connector.

E. Disconnect the P1 connector.

Note: Wiggle the harness during the following measurements in order to reveal an intermittent condition.

F. Measure the resistance between terminals P1-20 (CAN data link +) and P1-21 (CAN data link -).

Expected Result:

The resistance is between 57 and 63 Ohms.

Results:

- OK – The resistance is between 57 and 63 Ohms. Proceed to Test Step 5.
- Not OK – The resistance is between 114 Ohms and 126 Ohms. A termination resistor is missing.

Repair: Verify that two termination resistors are connected to the data link. One resistor must be located on each end of the data link. The engine is shipped with one termination resistor that is installed between the ECM and the customer connector.

Refer to the appropriate electrical schematic in order to determine the missing resistor. Replace the missing resistor. Verify that the problem is resolved.

STOP.

- Not OK – The resistance is less than 57 Ohms. Proceed to Test Step 3.
- Not OK – The resistance is greater than 126 Ohms. Proceed to Test Step 4.

Test Step 3. Check for a Short Circuit

- Remove both termination resistors from the CAN data link.
- Measure the resistance between the points that are listed in Table 31. Be sure to wiggle the wires in the harnesses as you make each resistance measurement.

Table 31

Resistance Measurements for the CAN Data Link	
Connector and Terminal	Terminal
P1-20 (CAN data link +)	All of the other terminals on the P1 connector
	Engine ground
P1-21 (CAN data link -)	All of the other terminals on the P1 connector
	Engine ground

Expected Result:

Each check of the resistance indicates an open circuit.

Results:

- OK – Each check of the resistance indicates an open circuit. Proceed to Test Step 4.
- Not OK – At least one check of the resistance does not indicate an open circuit. There is a short circuit in a harness. There may be a problem with a connector.

Repair: Repair the wiring and/or the connector. Replace part, if necessary. Verify that the problem is resolved.

STOP.

Test Step 4. Check for an Open Circuit

- Remove both termination resistors from the CAN data link.
- Fabricate a jumper wire. Use the jumper wire in order to create a short circuit between terminals A and B on the tee's connector for the termination resistor. This will replace the termination resistor with a short circuit.
- Measure the resistance between terminals P1-20 (CAN data link +) and P1-21 (CAN data link -).
- Remove the jumper wire from the tee. Connect the termination resistors to the data link.
- Connect the J1/P1 connectors.

Expected Result:

The resistance is less than ten Ohms.

Results:

- OK – The resistance is less than ten Ohms. There is not an open circuit. Proceed to Test Step 5.

i04010976

- Not OK – The resistance is more than ten Ohms. There is an open circuit or excessive resistance in the circuit. There may be a problem in a connector.

Repair: Repair the wiring and/or the connector. Replace part, if necessary. Verify that the problem is resolved.

STOP.

Test Step 5. Check the Mini Marine Power Display

- A. Connect the mini marine power display to another engine.
- B. Operate the engine and monitor the mini marine power display.

Expected Result:

The mini marine power display operates properly.

Results:

- OK – The mini marine power display operates properly on another engine.

Repair: Connect the display to the original engine. If the display operates correctly, there may be a problem with an electrical connector. Refer to the diagnostic functional test Troubleshooting, "Electrical Connectors - Inspect".

If the display does not operate correctly on the original engine, there may be a problem with the ECM.

If the display does not operate correctly, replace the ECM. Refer to electronic troubleshooting Troubleshooting, "Replacing the ECM".

STOP.

- Not OK – The mini marine power display does not operate properly on another engine.

Repair: Replace the mini marine power display. Verify that the problem is resolved.

STOP.

Coolant Level Sensor Circuit - Test

System Operation Description:

Use this procedure to troubleshoot any suspect problems with the coolant level sensor.

The coolant level sensor monitors the engine coolant level in order to warn the operator in the event that the coolant level is low. The coolant level sensor is located on the side of the expansion tank.

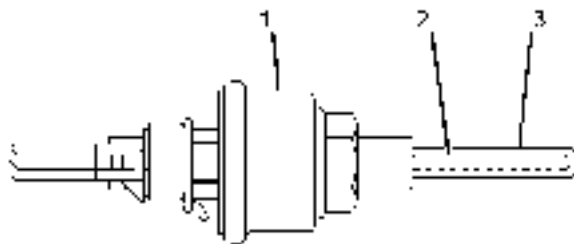

Illustration 28

g01132350

Typical example of a coolant level sensor

- (1) Sensor
- (2) Brass rod
- (3) Plastic cover

Coolant level sensor (1) contains no moving parts. The sensor detects variations in capacitance. The sensor's probe contains a brass rod (2) that is covered with plastic (3). The brass rod is one plate of a capacitor. The plastic cover is the capacitor's dielectric. The coolant is the other plate of the capacitor.

When the probe is immersed in coolant, the sensor senses a particular capacitance. The sensor responds by creating a short circuit between the signal wire and the ground wire.

When the probe is not immersed in coolant, the capacitance value changes. The change in the capacitance value is detected by the sensor's electronic circuits. The circuits apply approximately +5 VDC to the signal wire. The ECM detects the voltage and the ECM activates either a E2143-1 or a E2143-2 event code.

The event codes are probably caused by a low coolant level. The next likely cause is a problem with a wiring harness or with the sensor. The least likely cause is a problem with the ECM.

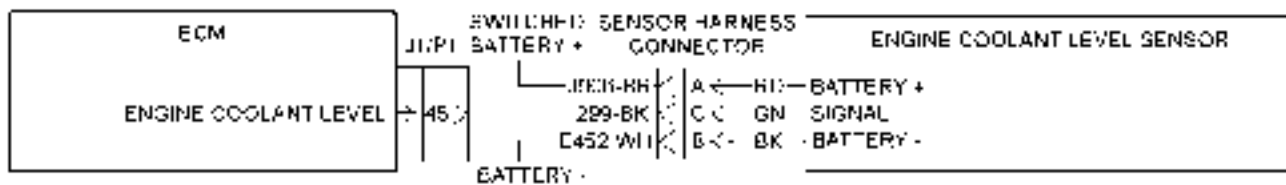

Illustration 29

g02192043

Schematic for the coolant level sensor

WARNING

Pressurized System: Hot coolant can cause serious burns. To open the cooling system filler cap, stop the engine and wait until the cooling system components are cool. Loosen the cooling system pressure cap slowly in order to relieve the pressure.

Test Step 1. Inspect the Electrical Connectors and the Wiring

A. Remove the electrical power from the ECM.

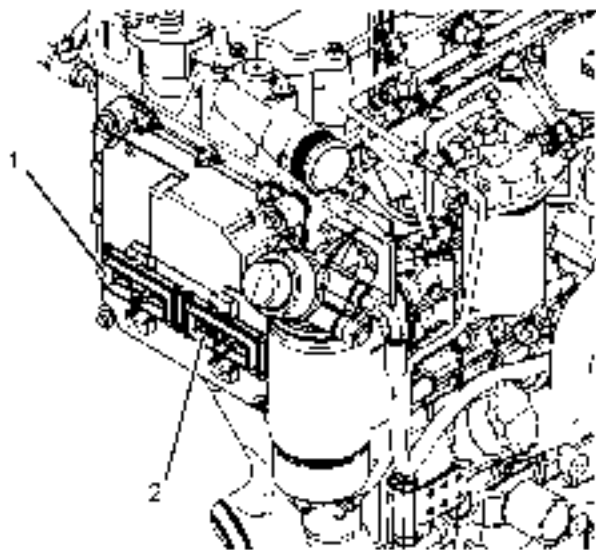

Illustration 30

g02186493

Engine components for the coolant level sensor

- (1) J1/P1/E-C1 connectors
- (2) J2/P2/A-C1 connectors

B. Thoroughly inspect connectors (1) and (2). Inspect the connectors for sensor. Refer to the diagnostic functional test Troubleshooting, "Electrical Connectors - Inspect" for details.

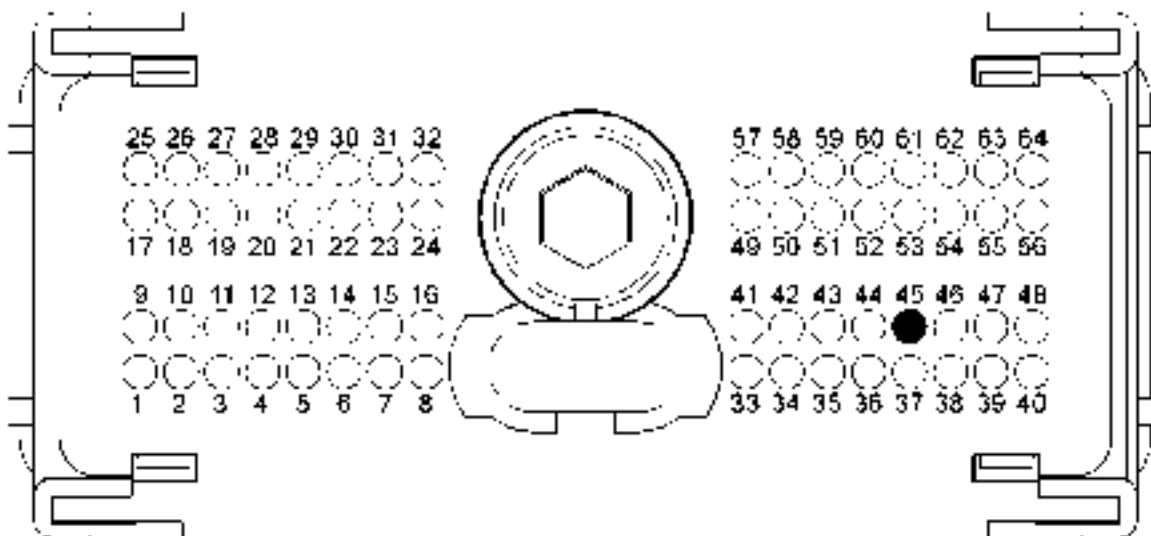

Illustration 31

g02192045

P1 terminals that are associated with the coolant level sensor
(P1-45) Coolant level

- C. Perform a 45 N (10 lb) pull test on each of the wires that are associated with the circuit for the coolant level sensor.
- D. Check the allen head screw on each ECM connector for the proper torque. Refer to the diagnostic functional test Troubleshooting, "Electrical Connectors - Inspect".

Expected Result:

All connectors, pins, and sockets are completely coupled and/or inserted, and the harness and wiring are free of corrosion, of abrasion or of pinch points.

Results:

- OK – The connectors and wiring are OK. Proceed to Test Step 2.
- Not OK – There is a problem with the connectors and/or the wiring.

Repair: Repair the wiring and connectors or replace the wiring or the connectors. Ensure that all of the seals are properly connected. Verify that the repair eliminates the problem.

Verify that the repair eliminates the problem.

STOP.

Test Step 2. Check the Supply Voltage at the Sensor Connector

- A. Disconnect the coolant level sensor.

- B. Restore the electrical power to the ECM.



Illustration 32

g01132478

Harness connector for the coolant level sensor

- (A) Battery positive
- (B) Battery negative

- C. Measure the voltage between terminals A and B at the harness connector for the coolant level sensor.

- D. Remove the electrical power from the ECM.

Expected Result:

The voltage measurement is 12 or 24 VDC.

Results:

- OK – The voltage measurement is 12 or 24 VDC. The supply voltage is reaching the sensor. Proceed to Test Step 3.
- Not OK – The voltage measurement is not 12 or 24 VDC. The digital sensor supply voltage is not reaching the sensor.

Repair: Refer to the diagnostic functional test Troubleshooting, “Digital Sensor Supply Circuit - Test”.

STOP.

Test Step 3. Check the Coolant Level

WARNING

Pressurized System: Hot coolant can cause serious burns. To open the cooling system filler cap, stop the engine and wait until the cooling system components are cool. Loosen the cooling system pressure cap slowly in order to relieve the pressure.

- A. Stop the engine.
- B. After allowing the engine to cool, check the coolant level.

Expected Result:

The coolant is at the proper level.

Results:

- OK – The coolant is at the proper level. Proceed to Test Step 4.
- Not OK – The coolant level is low.

Repair: Add coolant.

Verify that the repair eliminates the problem. Identify the source of the coolant leak and fix the problem.

STOP.

Test Step 4. Disconnect the Coolant Level Sensor and Monitor the Status of “Coolant Level”

- A. Connect the electronic service tool to the service tool connector. Refer to Troubleshooting, “Electronic Service Tools”.
- B. Disconnect the coolant level sensor connector.
- C. Restore the electrical power to the ECM.
- D. Monitor the status of “Coolant Level” on the electronic service tool.
- E. Remove the electrical power from the ECM.

Expected Result:

The status changes from “OK” to “Low” when the sensor is disconnected.

Results:

- OK – The status is “Low” when the sensor is disconnected. Proceed to Test Step 5.
- Not OK – The status is “OK” when the sensor is disconnected. Proceed to Test Step 6.

Test Step 5. Short the Harness and Monitor the Status of “Coolant Level”

- A. Restore the electrical power to the ECM and monitor the status of “Coolant Level” on the electronic service tool.
- B. Install a jumper wire between terminals B and C on the harness connector for the coolant level sensor.
- C. Monitor the status of “Coolant Level” on electronic service tool while the jumper wire is installed.
- D. Remove the jumper wire.
- E. Remove the electrical power from the ECM.

Expected Result:

The status changes from “Low” to “OK” when the jumper wire is installed.

Results:

- OK – The status changes from “Low” to “OK” when the jumper wire is installed. The ECM and the wiring to the coolant level sensor are OK.

Repair: Perform the following procedure:

WARNING

Pressurized System: Hot coolant can cause serious burns. To open the cooling system filler cap, stop the engine and wait until the cooling system components are cool. Loosen the cooling system pressure cap slowly in order to relieve the pressure.

1. Drain the coolant below the level of the coolant level sensor.
2. Restore the electrical power to the ECM and monitor the status of “Coolant Level” on the electronic service tool.
3. Remove the electrical power from the ECM.

If the status of the “Coolant Level” is “OK”, replace the sensor. Verify that the problem is resolved.

If the status for the coolant level is “Low”, connect the sensor. Fill the cooling system. Return the engine to service.

STOP.

- Not OK – Shorting the harness does not affect the status on the electronic service tool. Proceed to Test Step 6.

Test Step 6. Check the Wiring for an Open Circuit

- Remove the electrical power from the ECM.
- Disconnect the J1/P1/E-C1 and J2/P2/A-C1 connectors.

Note: Wiggle the harness during the following measurements in order to reveal an intermittent condition.

- Measure the resistance between the following terminals:

- Terminal A of the sensor harness connector (12 or 24 VDC)
- Terminal B of the sensor harness connector (Return)
- P1-45 (Engine Coolant Level) to terminal C of the sensor harness connector (Engine Coolant Level)

Expected Result:

Each resistance measurement is less than ten Ohms.

Results:

- OK – Each resistance measurement is less than ten Ohms. There are no opens in the wiring. Proceed to Test Step 7.
- Not OK – At least one resistance measurement is greater than ten Ohms. There is an open circuit or excessive resistance in the harness. There may be a problem in a connector.

Repair: Repair the wire and/or the connector, when possible. Replace parts, if necessary. Verify that the problem is resolved.

STOP.

Test Step 7. Check the Wiring for a Short Circuit

- Remove the electrical power from the ECM.

Note: Wiggle the harness during the following measurements in order to reveal an intermittent condition.

- Measure the resistance between the points that are listed in Table 32. Be sure to wiggle the wires in the harnesses as you make each resistance measurement.

Table 32

Resistance Measurements for the Circuit for the Coolant Level Sensor	
Connector and Terminal	Terminal
P1-45 (Engine Coolant Level)	All of the other terminals on the P2 connector
	All of the terminals on the P1 connector
	Engine ground

Expected Result:

Each check of the resistance indicates an open circuit.

Results:

- OK – Each check of the resistance indicates an open circuit. Proceed to Test Step 8.
- Not OK – At least one check of the resistance does not indicate an open circuit. There is a problem in the harness. There may be a problem in a connector.

Repair: Repair the wire and/or the connector, when possible. Replace parts, if necessary. Verify that the problem is resolved.

STOP.

Test Step 8. Create a Short Circuit at the ECM

- Remove the terminal from locations P1-45 and negative battery.
- Install the ends of a jumper wire into locations P1-45 and negative battery. This will create a short circuit at the ECM connectors.
- Restore the electrical power to the ECM and monitor the status of “Coolant Level” on the electronic service tool.
- Remove the jumper wire. Monitor the status of “Coolant Level” on the electronic service tool.

Expected Result:

The status is “Low” when the jumper wire is not connected. The status is “OK” when the jumper wire is connected.

Results:

- OK – The status is “Low” when the jumper wire is not connected. The status is “OK” when the jumper wire is connected. The ECM is properly reading the switch input.

Repair: Perform the following procedure:

1. Remove the jumper wire from the ECM connector.
2. Install the two terminals into the correct locations on the ECM connector. Pull on the two wires in order to verify proper installation of the terminals.

The problem appears to be resolved. The original problem was probably caused by a poor electrical connection. Return the engine to service.

STOP.

- Not OK – The status is “Low” when the jumper wire is connected. The ECM is not reading the switch input.

Repair: Temporarily install a new ECM. Refer to electronic troubleshooting Troubleshooting, “Replacing the ECM”.

If the new ECM works correctly, install the original ECM and verify that the problem returns. If the new ECM works correctly and the original ECM does not work correctly, replace the original ECM. Verify that the problem is resolved.

STOP.

The data link is the standard data link that is used by the ECM in order to communicate with the electronic service tool.

The ECM provides multiple connections for the data link. The technician must ensure that the correct connector is being tested. The connection that is used is dependent on the application.

If the diagnostic connector is on the engine, the positive data link signal will be from P2:21 to E-C3:D. The negative data link signal will be from P2:20 to E-C3:E.

If the diagnostic connector is off the engine, the positive data link signal will be from E-C1:23 to “E-C3:D” of the diagnostic connector. The negative data link signal will be from E-C1:24 to “E-C3:E” of the diagnostic connector.

The following information refers to the pin number. Ensure that the correct connector is used.

Communication

The electronic service tool may indicate the following error message:

The version of the ECM is not recognized and the integrity of the changed parameters and displayed data is not guaranteed.

This message will indicate that the version of the software that is in the electronic service tool is not the same version of the software that is in the ECM. Install the latest version of the electronic service tool software in order to rectify the fault.

i04012487

Data Link Circuit - Test

System Operation Description:

Use this procedure under the following circumstances:

Use this procedure if the electronic service tool will not communicate with the Electronic Control Module (ECM) through the data link.

The following background information is related to this procedure:

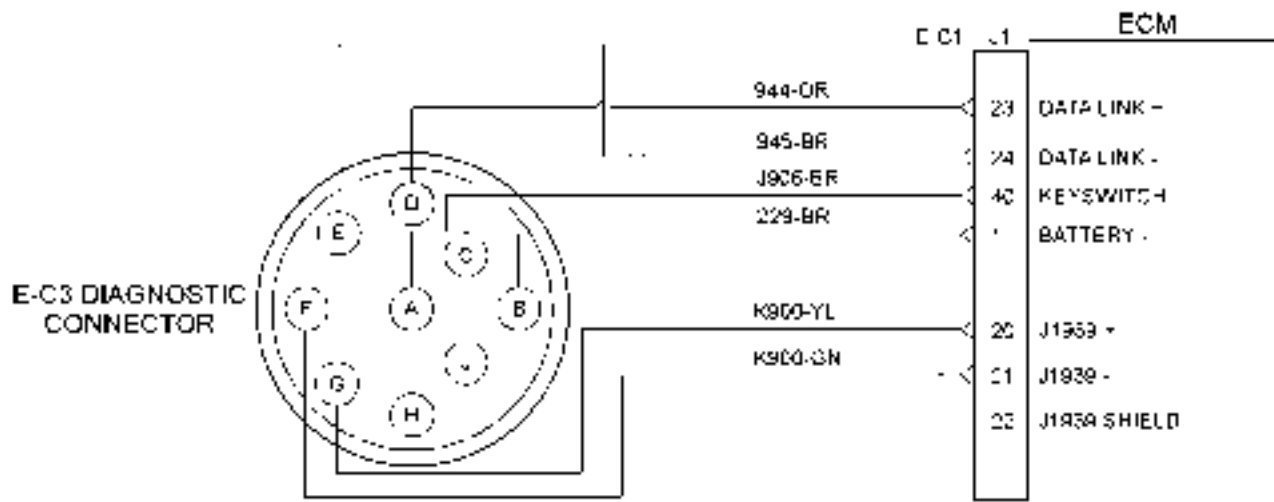

Illustration 33
Schematic of the diagnostic connector

g02192873

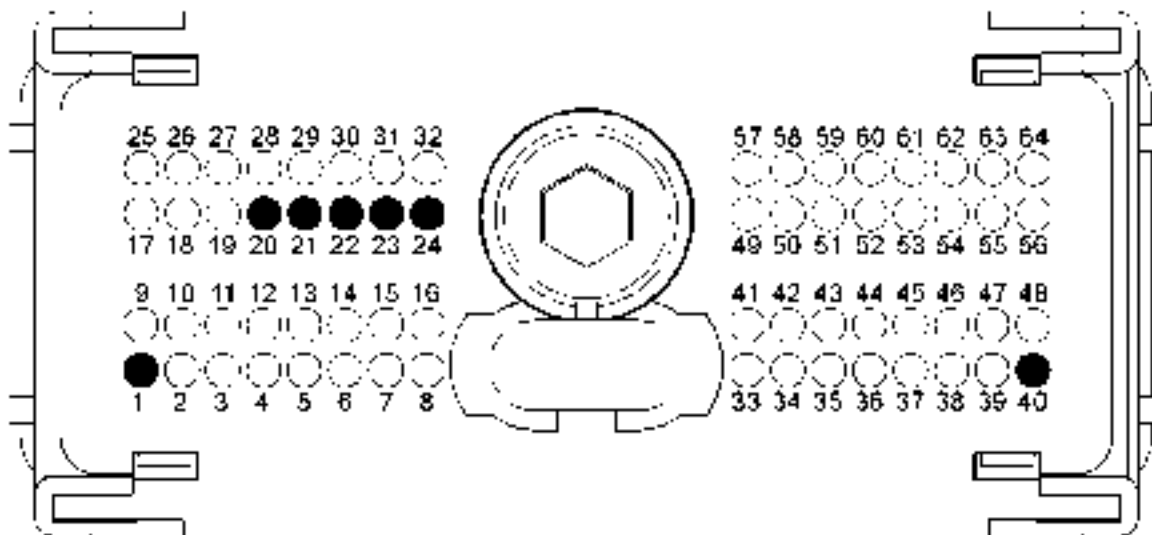

Illustration 34
Typical view of the pin locations on the P1 connector

g02273797

- (1) Battery +
- (20) J1939 +
- (21) J1939 -
- (22) J1939 Shield
- (23) Data link +
- (24) Data link -

- (40) Keyswitch

Test Step 1. Inspect Electrical Connectors and Wiring

A. Thoroughly inspect the following electrical connectors:

- P1/J1 ECM connector
- E-C3 diagnostic connector

Refer to Troubleshooting, "Electrical Connectors - Inspect" for details.

B. Perform a 45 N (10 lb) pull test on each of the wires in the ECM connectors that are associated with the data link.

C. Check the screw for the ECM connectors for correct torque of 5.0 N·m (44 lb in).

D. Check the harness for abrasion and pinch points from the wires that connect the diagnostic connector to the ECM.

Expected Result:

All connectors, pins, and sockets should be completely coupled and/or inserted. The harness should be free of corrosion, abrasion and/or pinch points.

Results:

- OK – Proceed to Test Step 2.
- Not OK

Repair: Perform the following repair:

Repair the connectors and/or the harness, or replace the connectors and/or the harness. Ensure that all of the seals are correctly in place and ensure that the connectors are completely coupled.

Use the electronic service tool in order to clear all logged diagnostic codes and then verify that the repair eliminates the fault.

STOP.

Test Step 2. Determine the Type of Fault on the Data Link

- Connect the electronic service tool to the diagnostic connector that is on the engine harness or on the application.
- Turn the keyswitch to the ON position.

Expected Result:

The power lamp should illuminate on the communications adapter. The power lamp on the communications adapter may illuminate when the keyswitch is in any position.

Results:

- OK – The communications adapter is currently receiving the correct voltage.

Repair: If you are redirected to this step from “Check the wiring of the Diagnostic Connector” and if a jumper wire has been installed between pin “A” on the diagnostic connector and the positive terminal on the battery and if a jumper wire has been installed between pin “B” on the diagnostic connector and the negative terminal on the battery, remove the jumper wires and then repair the harness. If the harness cannot be repaired, replace the harness.

Proceed to Test Step 5.

- Not OK – The communications adapter is not receiving the correct voltage. Proceed to Test Step 3.

Test Step 3. Check the Wiring of the Diagnostic Connector

Illustration 35

g01801997

Typical view of the diagnostic connector from the wire side

- (A) Switched battery +
- (B) Battery ground (GND)
- (D) Data link +
- (E) Data link -

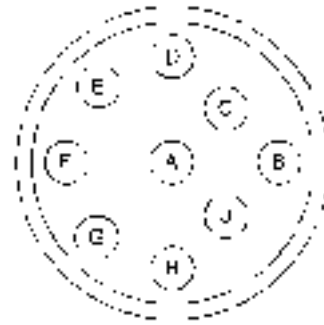
- If the communications adapter is connected to the diagnostic connector on the engine, ensure that pin “A” and pin “B” are wired on the engine harness side of the connector.

Expected Result:

The pins are wired.

Results:

- OK – The harness is fully wired. Proceed to Test Step 4.
- Not OK – The data link connector power connections are not wired.

Repair: Fabricate a jumper wire in order to connect pin “A” of the diagnostic connector to battery+ and pin “B” to the battery-.

Proceed to Test Step 2.

Test Step 4. Check the Battery Voltage at the Diagnostic Connector

- Turn the keyswitch to the ON position.
- Use a multimeter in order to measure the voltage from pin A (battery+) and pin B (ground) of the diagnostic connector.

Expected Result:

The voltage is between 22.0 VC and 27.0 VDC for a 24 Volt system and between 11.0 Volts DC and 13.5 VDC for a 12 Volt system.

Results:

- OK – The diagnostic connector is currently receiving the correct voltage. Proceed to Test Step 5.
- Not OK – The diagnostic connector is not receiving the correct voltage.

Repair: Refer to Troubleshooting, “Engine Wiring Information”.

Proceed to Test Step 2.

Test Step 5. Check the Data Link Connections

- A. Turn the keyswitch to the OFF position.
- B. Disconnect the communications adapter from the diagnostic connector.
- C. If the diagnostic connector is installed on the application, disconnect P1 OEM connector from connector J1. Check the resistance between E-C1:23 and diagnostic pin “D”. If the diagnostic connector is installed on the engine, disconnect P2 from connector J2. Check the resistance between P2:21 and diagnostic pin “D”.
- D. If the diagnostic connector is installed on the application, check the resistance between P1:24 and diagnostic pin “E”. If the diagnostic connector is installed on the engine, check the resistance between P2:20 and diagnostic pin “E”.

Expected Result:

The resistance that is measured is less than 10 Ohms.

Results:

- OK – The resistance is less than 10 Ohms. Proceed to Test Step 6.
- Not OK – The resistance is greater than 10 Ohms.

Repair: Perform the following repair:

Repair the connectors and/or the harness, or replace the connectors and/or the harness. Ensure that all of the seals are correctly in place and ensure that the connectors are completely coupled.

Use the electronic service tool in order to clear all logged diagnostic codes and then verify that the repair eliminates the fault.

STOP.

Test Step 6. Change the Components of the Electronic Service Tool

- A. If another electronic engine is available, connect the electronic service tool to the other engine. Ensure that the same cables are used.
- B. Turn the keyswitch to the ON position. Determine if the electronic service tool operates correctly on the other engine.
- C. If another engine is not available, obtain a replacement communications adapter and a replacement set of electronic service tool cables. Ensure that the set of electronic service tool cables are a complete set.
- D. Install the replacement communications adapter and electronic service tool cables and connect to the diagnostic connector.
- E. Turn the keyswitch to the ON position.
- F. If changing the communications adapter or the electronic service tool cables allows the electronic service tool to operate correctly, use the following procedure:
 - a. Replace the components from the old set of electronic service tool cables into the new set of cables that operate. Replace one component at a time.
 - b. Apply power to the electronic service tool after each of the components is replaced. Use this method to find the faulty component.
- G. If changing the electronic service tool cables does not allow the electronic service tool to operate correctly, connect another electronic service tool.
- H. Turn the keyswitch to the ON position.

Expected Result:

Result 1 The original electronic service tool works on another engine.

Result 2 A different electronic service tool works on the original engine while the engine is being tested.

Results:

- Result 1 – Proceed to Test Step 7.
- Result 2

Repair: Send the faulty electronic service tool for repairs.

STOP.

Test Step 7. Connect the Electronic Service Tool and the ECM to another Battery

 **WARNING**

Batteries give off flammable fumes which can explode.

To avoid injury or death, do not strike a match, cause a spark, or smoke in the vicinity of a battery.

NOTICE

Do Not connect the Bypass Harness to the battery until the in-line fuse has been removed from the +Battery line. If the fuse is not removed before connection to the battery a spark may result.

Note: Refer to Troubleshooting, “Electronic Service Tools” for details of the bypass harness.

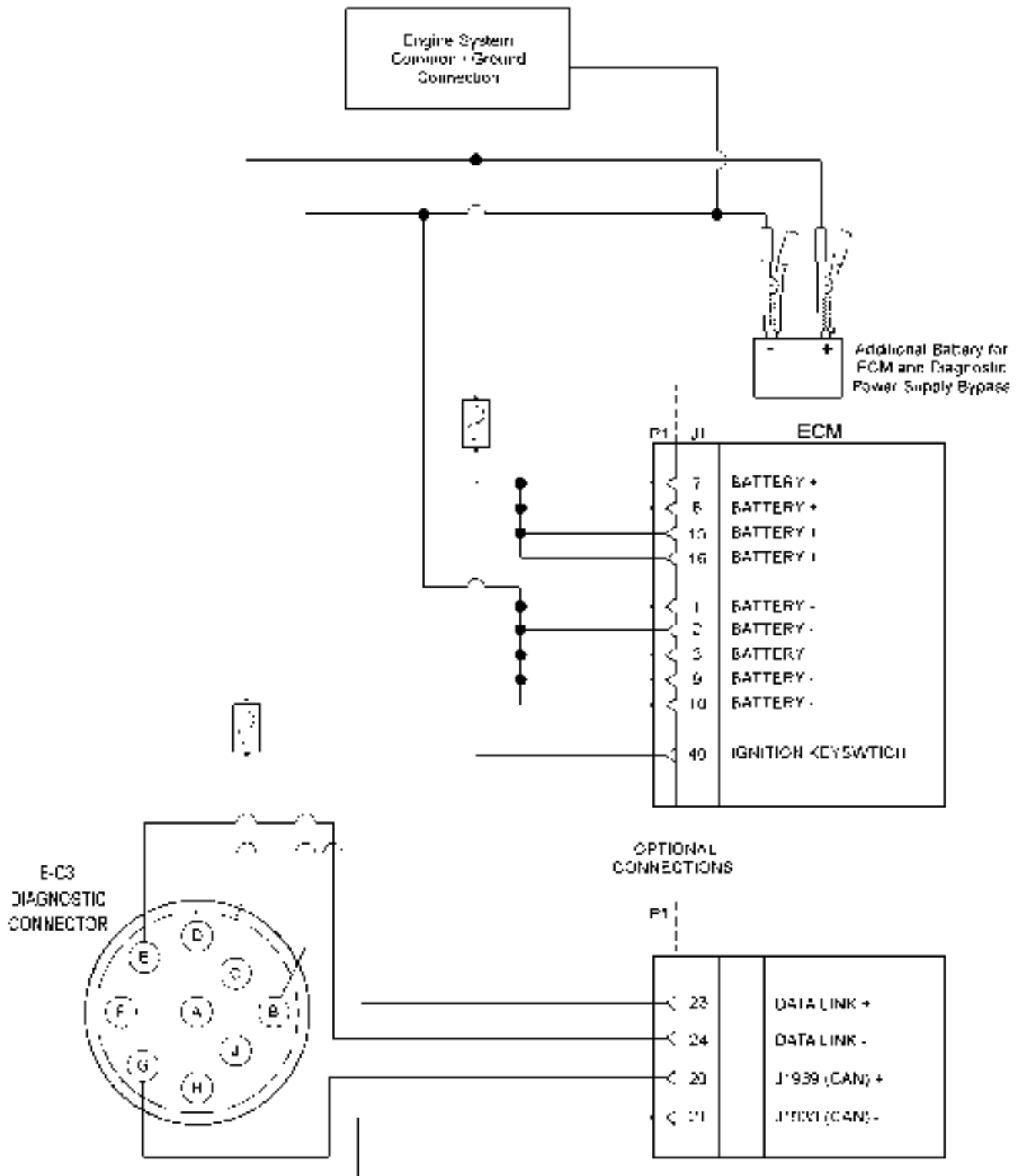

Illustration 36
 Schematic of the bypass harness connector

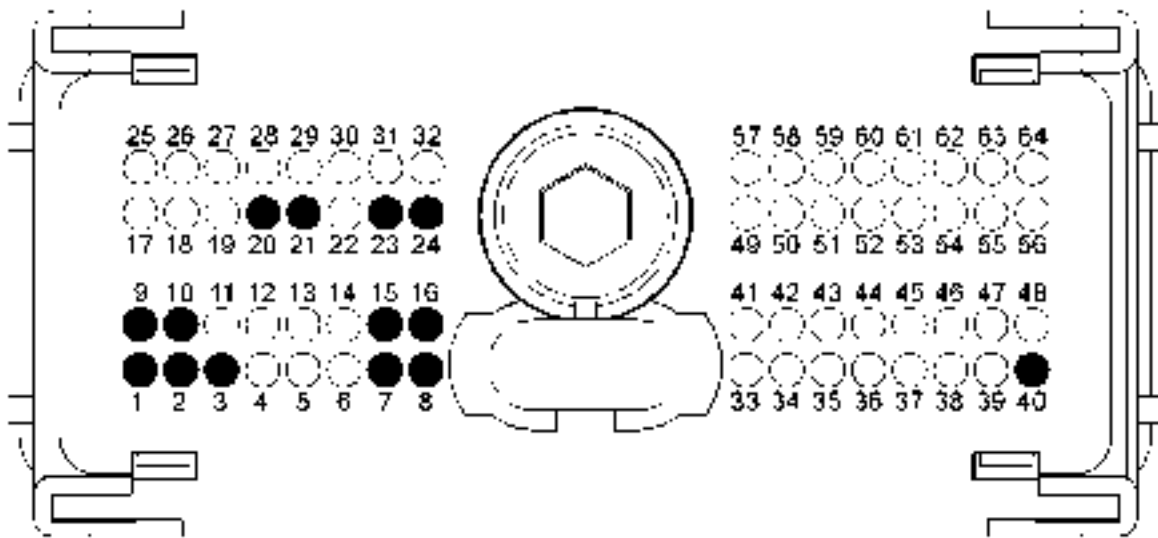

Illustration 37

g01802213

Typical view of the pin locations on the P1 connector for the diagnostic and data link connectors

- | | | |
|--------------------------|---------------------------|--------------------|
| (1) Battery ground (GND) | (9) Battery ground (GND) | (21) J1939 (CAN) - |
| (2) Battery ground (GND) | (10) Battery ground (GND) | (23) Data link + |
| (3) Battery ground (GND) | (15) Battery + | (24) Data link - |
| (7) Battery + | (16) Battery + | (40) Keyswitch |
| (8) Battery + | (20) J1939 (CAN) + | |

A. Connect the battery wires from the bypass harness of the electronic service tool to a different battery that is not on the engine.

Expected Result:

The electronic service tool is operating correctly.

Results:

- Yes

Repair: Refer to Troubleshooting, “Engine Wiring Information”.

STOP.

- No

Repair: Perform the following repair:

1. Make sure that the latest flash file for the application is installed in the ECM. Refer to Troubleshooting, “Flash Programming”.

2. Contact the Technical Help Desk.

Note: This consultation can greatly reduce the repair time.

3. If the Technical Help Desk recommends the use of a test ECM, install a test ECM. Refer to Troubleshooting, “Replacing the ECM”.

4. Use the electronic service tool to recheck the system for active diagnostic codes.

5. If the fault is resolved with the test ECM, reconnect the suspect ECM.

6. If the fault returns with the suspect ECM, replace the ECM.

7. Use the electronic service tool in order to clear all logged diagnostic codes and then verify that the repair eliminates the fault.

STOP.

i02493833

ECM Memory - Test

System Operation Description:

This procedure covers the following diagnostic codes:

- 0253-02 Personality Module erratic, intermittent, or incorrect

Background Information

0253-02

The flash file in the Electronic Control Module (ECM) is from the wrong engine family. The engine will not start.

Correct the Condition

Determine the diagnostic code that is active.

Expected Result:

A 0253-02 diagnostic code is active.

Results:

- A 0253-02 code is active

Repair: Obtain the engine serial number. Use PTMI to determine the latest available flash file for the engine. Verify that the latest available flash file is loaded into the ECM.

STOP.

i03458880

Electrical Connectors - Inspect

System Operation Description:

Most electrical faults are caused by poor connections. The following procedure will assist in detecting faults in connectors and wiring. If a fault is found, correct the condition and verify that the fault is resolved.

Intermittent electrical faults are sometimes resolved by disconnecting and reconnecting connectors. It is very important to check for diagnostic codes immediately before disconnecting a connector. Also check for diagnostic codes after reconnecting the connector. If the status of a diagnostic code is changed due to disconnecting and reconnecting a connector, there are several possible reasons. The likely reasons are loose terminals, improperly crimped terminals, moisture, corrosion, and inadequate mating of a connection.

Follow these guidelines:

- Always use a 27610285 Removal Tool to remove the pins from the P1/P2 connectors.
- Always use a 2900A033 Crimp Tool to service Deutsch HD and DT connectors. Never solder the terminals onto the wires.
- Always use a 28170079 Removal Tool to remove wedges from DT connectors. Never use a screwdriver to pry a wedge from a connector.
- Always use a 2900A033 Crimp Tool to service AMP seal connectors.

- Refer to Troubleshooting, "ECM Harness Connector Terminals" in order to service the connectors for the Electronic Control Module (ECM).
- Always use a breakout harness for a voltmeter probe or a test light. Never break the insulation of a wire in order to access a circuit for measurements.
- If a wire is cut, always install a new terminal for the repair.

WARNING

The connection of any electrical equipment and the disconnection of any electrical equipment may cause an explosion hazard which may result in injury or death. Do not connect any electrical equipment or disconnect any electrical equipment in an explosive atmosphere.

Test Step 1. Check Connectors for Moisture and Corrosion

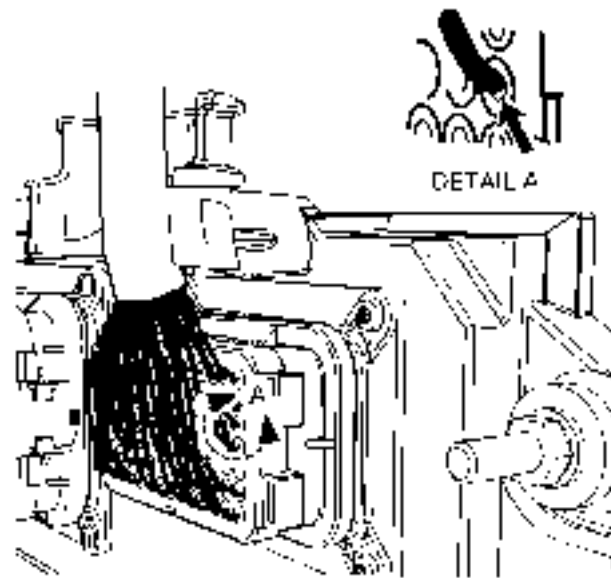

Illustration 38

g01131211

Leaky seal at the connector (typical example)

- A.** Inspect all the harnesses. Ensure that the routing of the wiring harness allows the wires to enter the face of each connector at a perpendicular angle. Otherwise, the wire will deform the seal bore. Refer to Illustration 38. This will create a path for the entrance of moisture. Verify that the seals for the wires are sealing correctly.

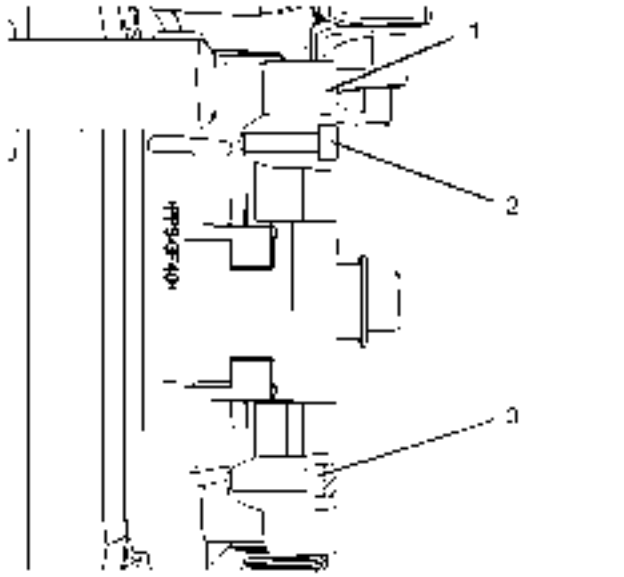

Illustration 39

g01131276

Diagram for the installation of a connector plug (typical example)

- (1) ECM connector
- (2) Correctly inserted plug
- (3) Incorrectly inserted plug

B. Ensure that the sealing plugs are in place. If any of the plugs are missing, replace the plug. Ensure that the plugs are inserted correctly into the connector. Refer to Illustration 39.

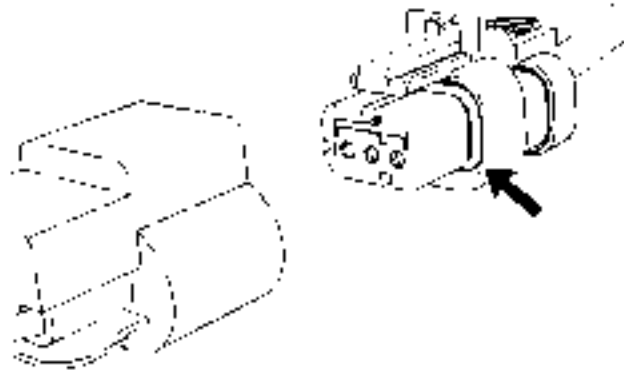

Illustration 40

g01131019

Seal for a three-pin connector (typical example)

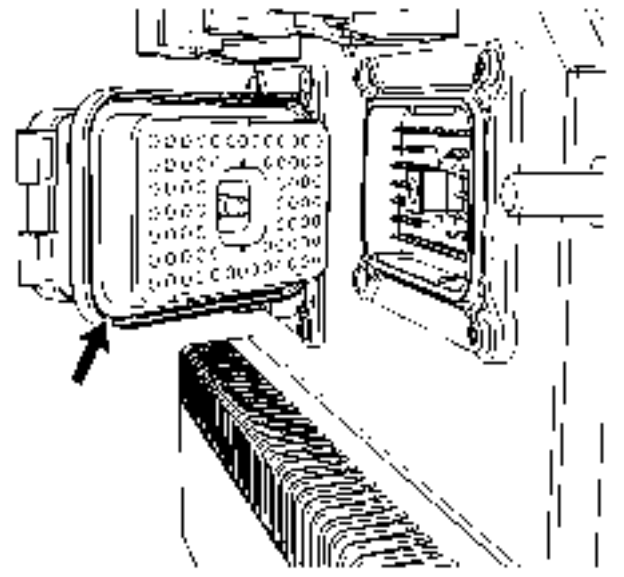

Illustration 41

g01131165

Seal for ECM connector (typical example)

C. Disconnect the suspect connector and inspect the connector seal. Ensure that the seal is in good condition. If necessary, replace the connector.

D. Thoroughly inspect the connectors for evidence of moisture entry.

Note: It is normal to see some minor seal abrasion on connector seals. Minor seal abrasion will not allow the entry of moisture.

If moisture or corrosion is evident in the connector, the source of the moisture entry must be found and the source of the moisture entry must be repaired. If the source of the moisture entry is not repaired, the fault will recur. Simply drying the connector will not fix the fault. Check the following items for the possible moisture entry path:

- Missing seals
- Incorrectly installed seals
- Nicks in exposed insulation
- Improperly mated connectors

Moisture can also travel to a connector through the inside of a wire. If moisture is found in a connector, thoroughly check the connector harness for damage. Also check other connectors that share the harness for moisture.

Note: The ECM is a sealed unit. If moisture is found in an ECM connector, the ECM is not the source of the moisture. Do not replace the ECM.

Expected Result:

The harness, connectors, and seals are in good condition. There is no evidence of moisture in the connectors.

Results:

- OK – The harness, connectors, and seals are in good condition. Proceed to Test Step 2.
- Not OK – A fault has been found with the harness or the connectors.

Repair: Repair the connectors or the wiring, as required. Ensure that all of the seals are correctly installed. Ensure that the connectors have been reattached.

If corrosion is evident on the pins, sockets or the connector, use only denatured alcohol to remove the corrosion. Use a cotton swab or a soft brush to remove the corrosion.

If moisture was found in the connectors, run the engine for several minutes and check again for moisture. If moisture reappears, the moisture is wicking into the connector. Even if the moisture entry path is repaired, it may be necessary to replace the wires.

Use the electronic service tool in order to clear all logged diagnostic codes and then verify that the repair eliminates the fault.

STOP.

Test Step 2. Check the Wires for Damage to the Insulation

- A.** Carefully inspect each wire for signs of abrasion, nicks and cuts.

Inspect the wires for the following conditions:

- Exposed insulation
- Rubbing of a wire against the engine
- Rubbing of a wire against a sharp point

- B.** Check all of the fasteners on the harness and the strain relief components on the ECM in order to verify that the harness is correctly secured. Also check all of the fasteners in order to verify that the harness is not compressed. Pull back the harness sleeves in order to check for a flattened portion of wire. A fastener that has been overtightened flattens the harness. This damages the wires that are inside the harness.

Expected Result:

The wires are free of abrasion, nicks and cuts and the harness is correctly clamped.

Results:

- OK – The harness is OK. Proceed to Test Step 3.
- Not OK – There is damage to the harness.

Repair: Repair the wires or replace the wires, as required.

Use the electronic service tool in order to clear all logged diagnostic codes and then verify that the repair eliminates the fault.

STOP.

Test Step 3. Inspect the Connector Terminals

- A.** Visually inspect each terminal in the connector. Verify that the terminals are not damaged. Verify that the terminals are correctly aligned in the connector and verify that the terminals are correctly located in the connector.

Expected Result:

The terminals are correctly aligned and the terminals appear undamaged.

Results:

- OK – The terminals are OK. Proceed to Test Step 4.
- Not OK – The terminals of the connector are damaged.

Repair: Repair the terminals and/or replace the terminals, as required.

Use the electronic service tool in order to clear all logged diagnostic codes and then verify that the repair eliminates the fault.

STOP.

Test Step 4. Perform a Pull Test on Each Wire Terminal Connection

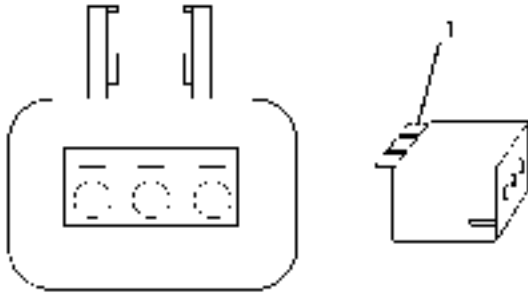

Illustration 42

g01802454

A typical example of the lock wedge.

(1) Lock wedge

- A. Ensure that the locking wedge for the connector is installed correctly. Terminals cannot be retained inside the connector if the locking wedge is not installed correctly.
- B. Perform the 45 N (10 lb) pull test on each wire. Each terminal and each connector should easily withstand 45 N (10 lb) of tension and each wire should remain in the connector body. This test checks whether the wire was correctly crimped in the terminal and whether the terminal was correctly inserted into the connector.

Expected Result:

Each terminal and each connector easily withstands 45 N (10 lb) of pull and each wire remains in the connector body.

Results:

- OK – All terminals pass the pull test. Proceed to Test Step 5.
- Not OK – A wire has been pulled from a terminal or a terminal has been pulled from the connector.

Repair: Use the CH11155 Crimp Tool to replace the terminal. Replace damaged connectors, as required.

Use the electronic service tool in order to clear all logged diagnostic codes and then verify that the repair eliminates the fault.

STOP.

Test Step 5. Check Individual Pin Retention into the Socket

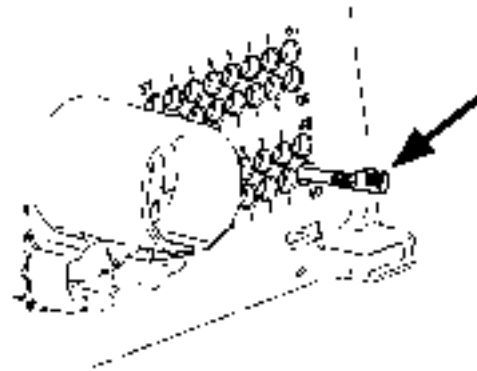

Illustration 43

g01802455

Diagram for testing pin retention

- A. Verify that the sockets provide good retention for the pins. Insert a new pin into each socket one at a time in order to check for a good grip on the pin by the socket.

Expected Result:

The sockets provide good retention for the new pin.

Results:

- OK – The terminals are OK. Proceed to Test Step 6.
- Not OK – Terminals are damaged.

Repair: Use the CH11155 Crimp Tool to replace the damaged terminals. Verify that the repair eliminates the problem.

Use the electronic service tool in order to clear all logged diagnostic codes and then verify that the repair eliminates the fault.

STOP.

Test Step 6. Check the Locking Mechanism of the Connectors

- A. Ensure that the connectors lock correctly. After locking the connectors, ensure that the two halves cannot be pulled apart.
- B. Verify that the latch tab of the connector is correctly latched. Also verify that the latch tab of the connector returns to the locked position.

Expected Result:

The connector is securely locked. The connector and the locking mechanism is not cracked or broken.

Results:

- OK – The connectors are in good repair. Proceed to Test Step 7.
- Not OK – The locking mechanism for the connector is damaged or missing.

Repair: Repair the connector or replace the connector, as required.

Use the electronic service tool in order to clear all logged diagnostic codes and then verify that the repair eliminates the fault.

STOP.

Test Step 7. Check the Screws on the ECM Connectors (64 way)

Visually inspect the screws for the ECM connectors. Ensure that the threads on each screw are not damaged.

- A.** Connect the ECM connectors.
- a. Use a 7 mm Torx screw in order to retain each of the ECM connectors.
 - b. Tighten the two Torx screws for the ECM connector to the correct torque of 5.0 ± 1.0 N·m (44 ± 9 lb in).

Note: If the threaded insert in the ECM is damaged, the ECM must be replaced. Refer to Disassembly and Assembly, “Electronic Control Module - Remove and Install”.

Expected Result:

The ECM connectors are secure and the Torx screws are correctly torqued.

Results:

- OK – The ECM connectors are secured. Proceed to Test Step 8.
- Not OK – The screws for the ECM connectors are damaged.

Repair: Repair the connectors or replace the connectors or screws, as required.

Use the electronic service tool in order to clear all logged diagnostic codes and then verify that the repair eliminates the fault.

STOP.

Test Step 8. Perform the “Wiggle Test” on the Electronic Service Tool

- A. Select the “Wiggle Test” from the diagnostic tests on the electronic service tool.
- B. Choose the appropriate group of parameters to monitor.
- C. Press the “Start” button. Wiggle the wiring harness in order to reproduce intermittent faults.

If an intermittent fault exists, the status will be highlighted and an audible beep will be heard.

Expected Result:

No intermittent faults were indicated during the “Wiggle Test”.

Results:

- OK – No intermittent faults were found. The harness and connectors appear to be OK. If this test was required as part of another procedure, return to that procedure and continue testing. If this test has resolved the fault, return the engine to service. STOP.
- Not OK – At least one intermittent fault was indicated.

Repair: Repair the harness or the connector.

Use the electronic service tool in order to clear all logged diagnostic codes and then verify that the repair eliminates the fault.

STOP.

i04010977

Electrical Power Supply Circuit - Test

System Operation Description:

Use this test to troubleshoot any suspect problems with power to the Electronic Control Module (ECM).

This procedure covers the following diagnostic codes:

- 168-00 “System Voltage High”
- 168-01 “System Voltage Low”
- 168-02 “System Voltage intermittent/erratic”

Use this test if there are intermittent engine shutdowns or if a difficulty in starting is not accompanied by loss of electrical accessories. Engine shutdowns that are accompanied by a loss of other electrical accessories indicate a problem in the keyswitch. This does not indicate a problem in the wiring at the engine's ECM. Verify that there are no problems with the starting system or the charging system before you use this test.

Unswitched battery voltage is supplied through the E-C2 connector to the ECM at P1-7, P1-8, and P1-15. The negative battery is supplied to the ECM at P1-1, P1-2, and P1-3. The ECM receives the input from the keyswitch at P1-40 when the keyswitch is in the ON position or the START position. When the ECM detects battery voltage at this input, the ECM will power up. When battery voltage is removed from this input, the ECM will power down. The ECM continuously receives battery voltage through the 20 Amp fuse for the ECM.

The engine ECM requires the keyswitch to be in the ON position in order to maintain communications with the electronic service tool.

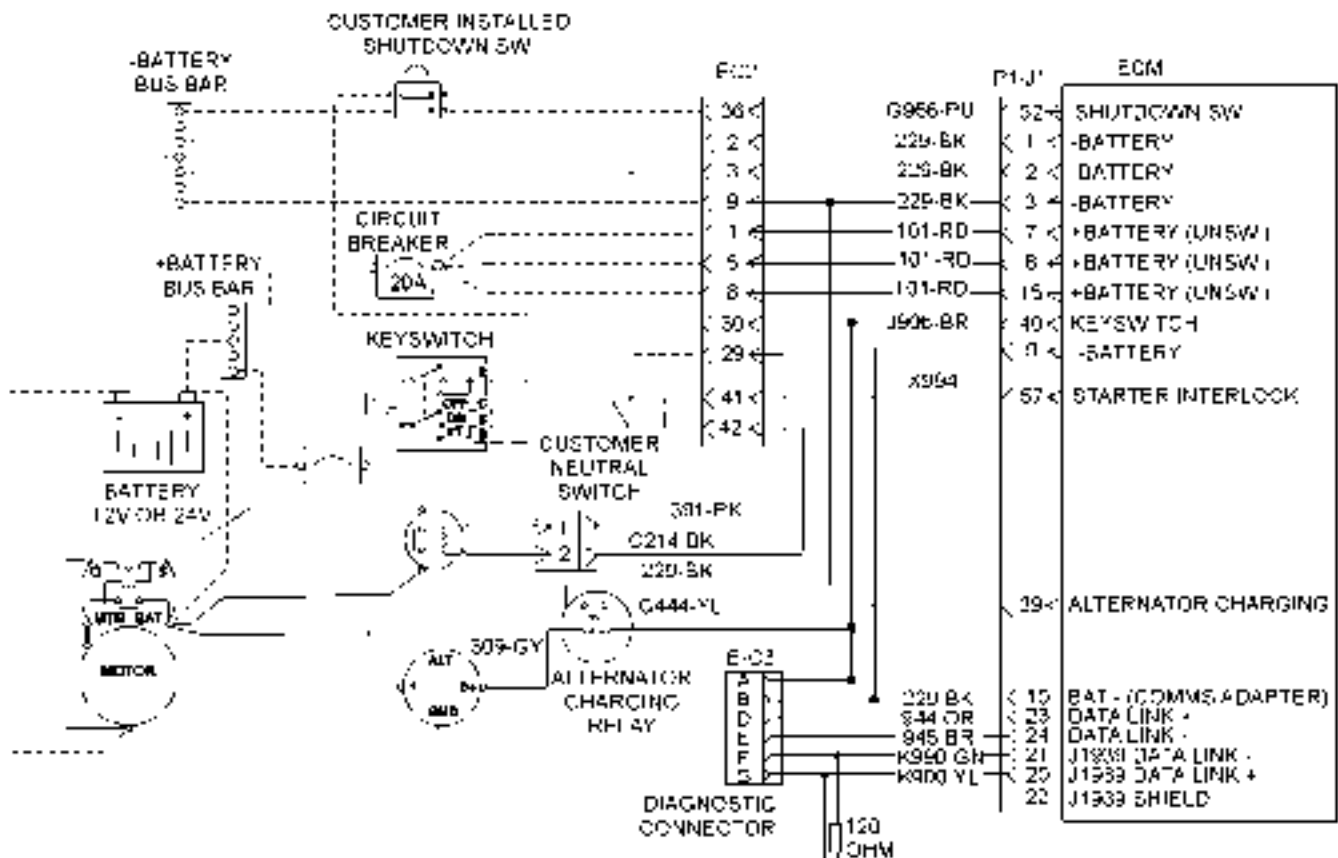

Illustration 44
Typical example

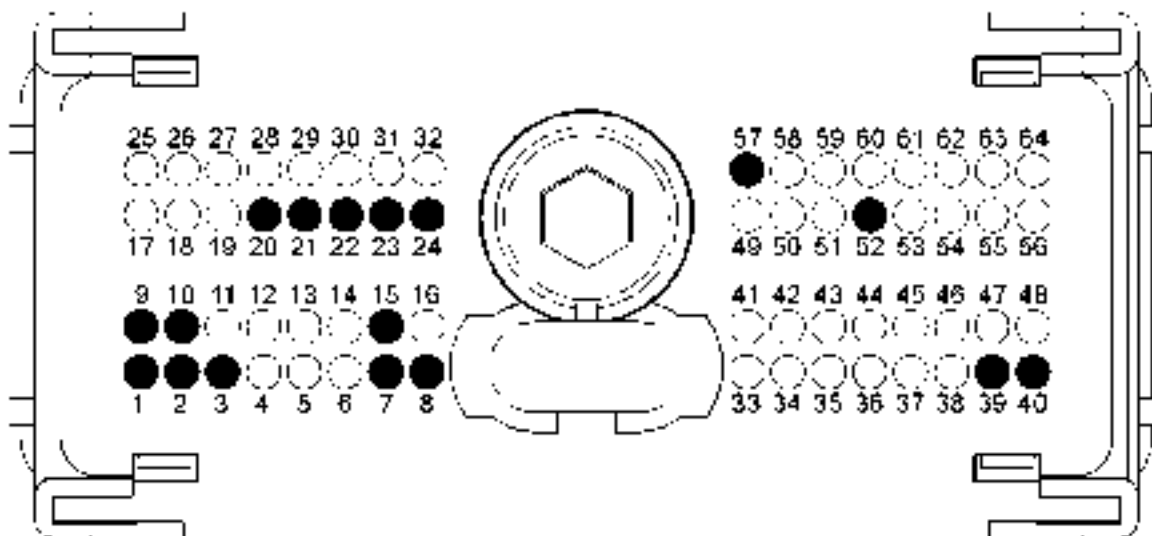

Illustration 45

g02199433

- (P1-1) Negative battery
- (P1-2) Negative battery
- (P1-3) Negative battery
- (P1-7) Unswitched positive battery
- (P1-8) Unswitched positive battery
- (P1-9) Negative battery

- (P1-10) Negative battery for communications adaptor
- (P1-15) Unswitched positive battery
- (P1-20) J1939 data link positive
- (P1-21) J1939 data link negative
- (P1-22) J1939 shield

- (P1-23) Data link positive
- (P1-24) Data link negative
- (P1-39) Alternator charging
- (P1-40) Keyswitch
- (P1-52) Remote shutdown switch
- (P1-57) Starter interlock

Test Step 1. Inspect Electrical Connectors and Wiring

- A. Turn the remote shutdown switch to the OFF position.
- B. Remove the electrical power from the ECM.
- C. Thoroughly inspect the ECM connectors J1/P1 and J2/P2. Inspect all of the connectors that are associated with this circuit. Refer to the diagnostic functional test Troubleshooting, "Electrical Connectors - Inspect".
- D. Perform a 45 N (10 lb) pull test on each of the wires in the ECM connector that are associated with the circuit.
- E. Check the ECM connector (allen head screw) for the proper torque. Refer to the diagnostic functional test Troubleshooting, "Electrical Connectors - Inspect".
- F. Check the harness and the wiring for abrasion and for pinch points.

Expected Result:

All connectors, pins, and sockets are completely inserted and coupled. The harness and wiring are free of corrosion, of abrasion, and of pinch points. All connections and grounds are tight and free of corrosion.

Results:

- OK – The harness and wiring are OK. Proceed to Test Step 2.
- Not OK – There is a problem in the connectors and/or wiring.

Repair: Repair the connectors or wiring and/or replace the connectors or wiring. Ensure that all of the seals are properly in place and ensure that the connectors are completely coupled.

Verify that the repair eliminates the problem.

STOP.

Test Step 2. Check the Battery Voltage at the ECM

- A. Turn the remote shutdown switch to the ON position.
- B. Disconnect the J1/P1 ECM connector.
- C. Restore the electrical power to the ECM.
- D. Measure the voltage between P1-7 (Unswitched Positive Battery) and P1-1 (Negative Battery).
- E. Measure the voltage between P1-8 (Unswitched Positive Battery) and P1-2 (Negative Battery).

F. Measure the voltage between P1-15 (Unswitched Positive Battery) and P1-3 (Negative Battery).

G. Measure the voltage between P1-40 (Keyswitch) and P1-3 (Negative Battery).

Expected Result:

The measured voltage is between 11.0 VDC and 13.5 VDC for a 12 volt system and between 22.0 VDC and 27.0 VDC for a 24 volt system with no suspected intermittent problems at this time.

Results:

- OK – The ECM is receiving the correct voltage.

Repair: If an intermittent condition is suspected, refer to the diagnostic functional test Troubleshooting, “Electrical Connectors - Inspect”.

STOP.

- Not OK – The voltage is not correct at the ECM. Proceed to Test Step 3.
- Keyswitch voltage out of range – Proceed to Test Step 4.

Test Step 3. Check the Batteries

A. Measure the no-load battery voltage at the battery posts.

B. Load test the batteries.

Expected Result:

The batteries pass the load test. The measured voltage is the minimum specification for a 12V or 24V system.

Results:

- OK – The batteries are OK.

Repair: There is an open circuit or excessive resistance in the wiring or connections between the batteries and the ECM. Verify that the 20 Amp circuit breaker for the ECM is not blown. Check the connections at the customer connector. Verify that the connection for the engine ground is clean and tight and that the battery disconnect switch is functioning properly. Repair the connectors or wiring and/or replace the connectors or wiring.

STOP.

- Not OK – The battery voltage is low or the battery did not pass the load test.

Repair: Recharge or replace the faulty batteries. Verify that the repair eliminates the problem.

STOP.

Test Step 4. Check the Voltage from the Keyswitch to the ECM

A. Remove the electrical power from the ECM.

B. Remove the wire from the terminal R of the keyswitch.

C. Restore the electrical power to the ECM.

D. Measure the voltage on terminal B of the keyswitch to engine ground.

E. Measure the voltage on terminal R of the keyswitch to engine ground.

F. Remove the electrical power from the ECM.

Expected Result:

Voltage is present on terminal B and terminal R at the keyswitch.

Results:

- OK – Voltage is present on terminal B and terminal R at the keyswitch.

Repair: If voltage is present on terminal R, repair the wire between the keyswitch and the ECM. Verify that the problem is eliminated.

STOP.

- Not OK – Voltage is not present on terminal B at the keyswitch.

Repair: If voltage is not present on terminal B, repair the wire between the +Battery and the keyswitch. Verify that the fuse for the keyswitch is not blown. Verify that the problem is eliminated.

STOP.

- Not OK – Voltage is not present on terminal R at the keyswitch.

Repair: If voltage is present on terminal B of the keyswitch but not present on terminal R, replace the keyswitch. Return all wiring to the original configuration. Verify that the problem is eliminated.

STOP.

i04010989

Engine Pressure Sensor Open or Short Circuit - Test

System Operation Description:

Use this procedure under the following conditions:

Use this procedure if another procedure has directed you here. Use this procedure if any of the following diagnostic codes are active:

- 0094-03 Fuel Pressure Sensor voltage above normal
- 0094-04 Fuel Pressure Sensor voltage below normal
- 0100-03 Engine Oil Pressure Sensor voltage above normal
- 0100-04 Engine Oil Pressure Sensor voltage below normal
- 0100-10 Engine Oil Pressure Sensor abnormal rate of change
- 1785-03 Intake Manifold Pressure Sensor voltage above normal
- 1785-04 Intake Manifold Pressure Sensor voltage below normal
- 1785-10 Intake Manifold Pressure Sensor abnormal rate of change
- 0127-03 Transmission Oil Pressure Sensor voltage above normal
- 0127-04 Transmission Oil Pressure Sensor voltage below normal
- 1797-03 Fuel Rail Pressure Sensor voltage above normal
- 1797-04 Fuel Rail Pressure Sensor voltage below normal

The following background information is related to this procedure:

The troubleshooting procedures for the diagnostic codes of each pressure sensor are identical. The 5 V sensor supply provides power to all 5 V sensors. The Electronic Control Module (ECM) supplies 5.0 ± 0.2 VDC to terminal "A" of each sensor connector. The sensor common from the ECM connector goes to terminal "B" of each sensor connector. The sensor supply is output short circuit protected. A short circuit to the battery will not damage the circuit inside the ECM.

Pull-up Voltage

The ECM continuously outputs a pull-up voltage on the circuit for the sensor signal wire. The ECM uses this pull-up voltage in order to detect an open in the signal circuit. When the ECM detects the presence of a voltage that is above a threshold on the signal circuit, the ECM will generate an open circuit diagnostic code (03) for the sensor.

If the sensor is disconnected at the sensor connector, the presence of pull-up voltage at the sensor connector indicates that the wires from the sensor connector to the ECM are not open or shorted to ground. If the sensor is disconnected at the sensor connector, the absence of pull-up voltage at the sensor connector indicates an open in the signal wire or a short to ground. If the sensor is disconnected at the sensor connector and the voltage at the sensor connector is different from pull-up voltage, the signal wire is shorted to another wire in the harness.

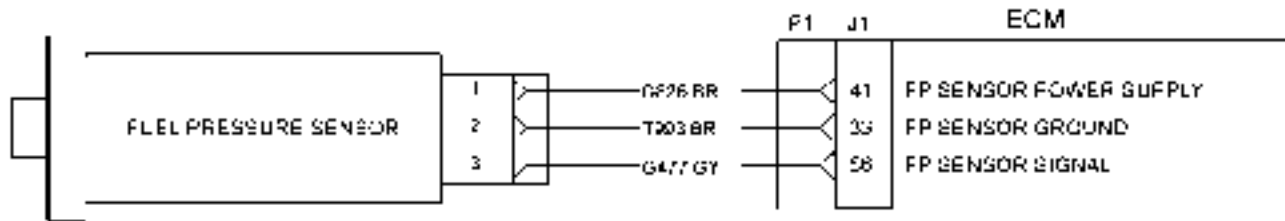

Illustration 46

g02256933

Typical example of the schematic for the sensors

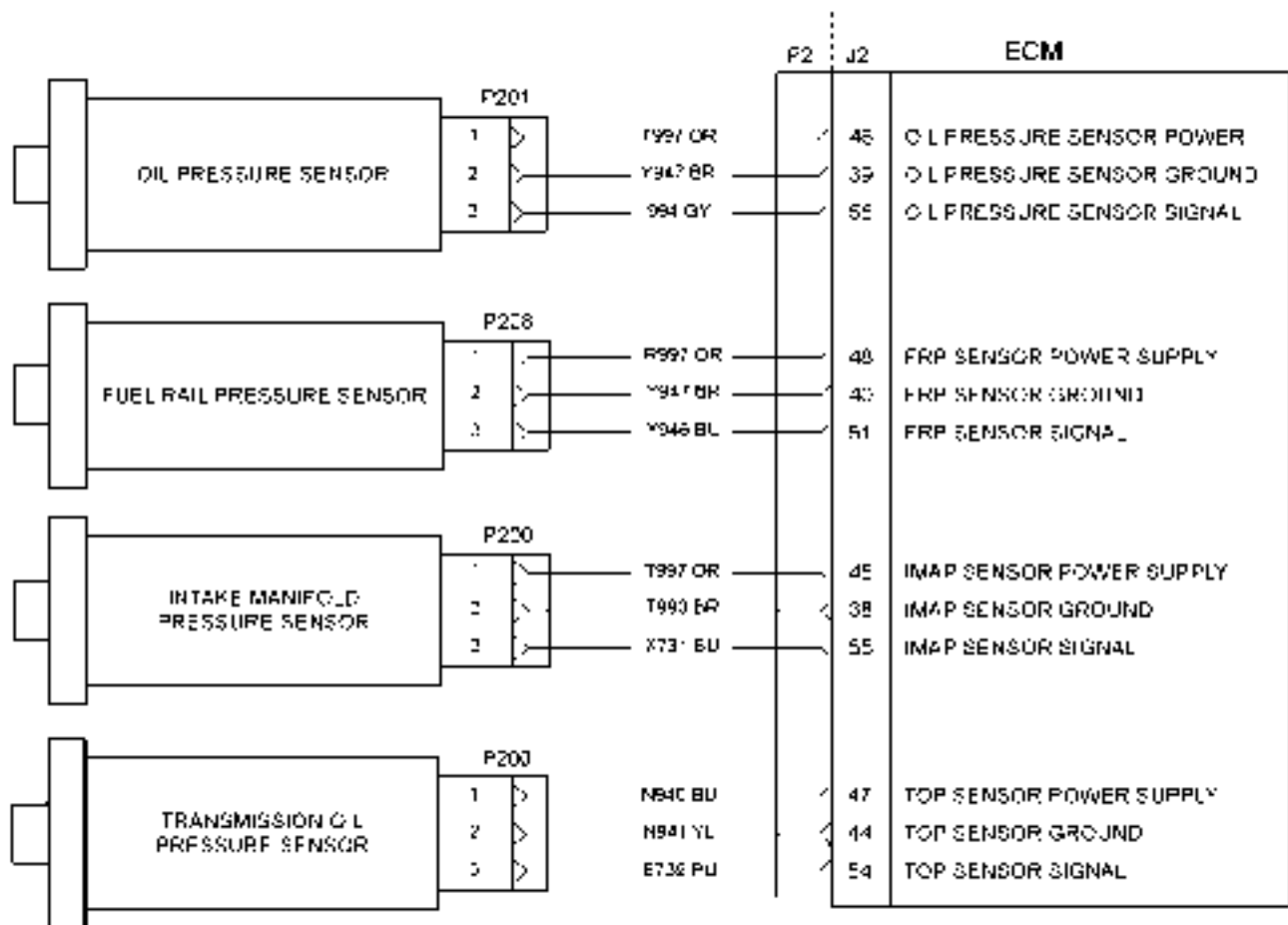

Illustration 47

g02192913

Typical example of the schematic for the sensors

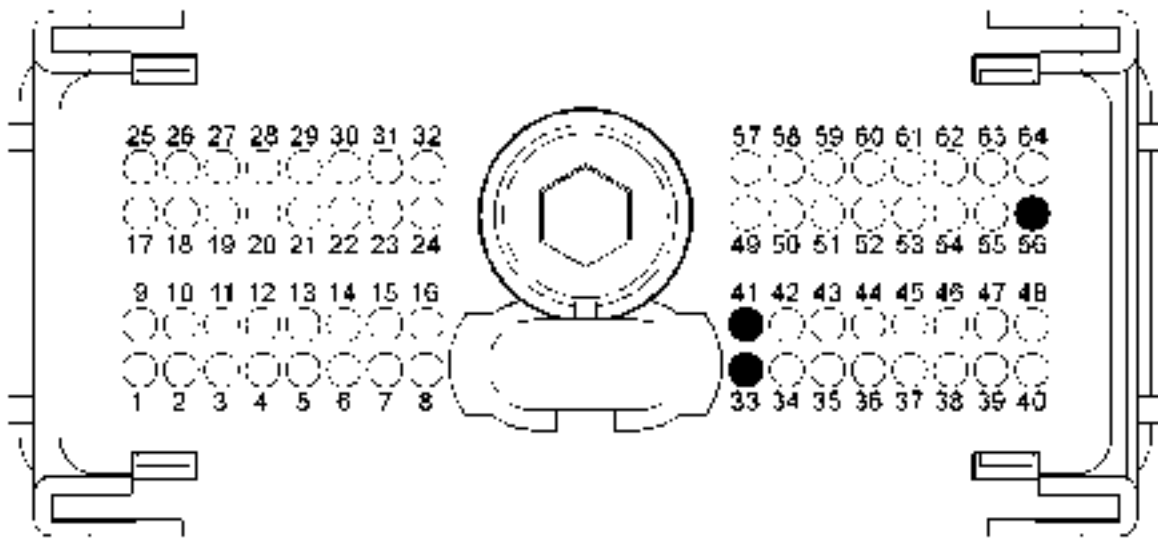

Illustration 48

g02256973

Typical view of the P1 pressure sensor pin locations

(33) Ground (GND) Fuel Rail Pressure Sensor

(41) Voltage supply (+5 VDC) Fuel Rail Pressure Sensor

(56) Signal (SIG) Fuel Rail Pressure Sensor

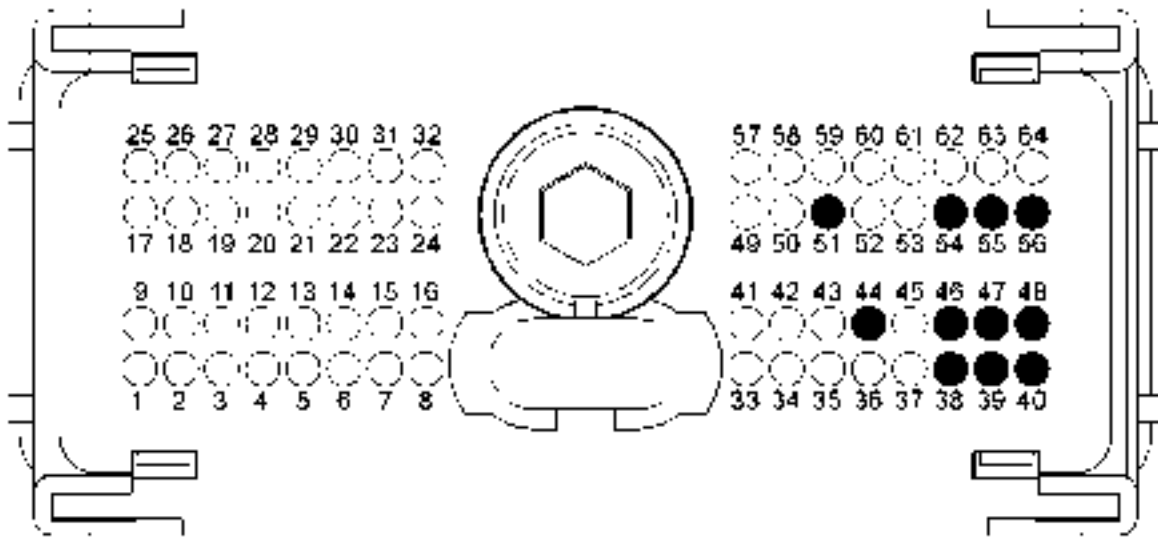

Illustration 49

g02192914

Typical view of the P2 pressure sensor pin locations

(38) Ground (GND) Intake Manifold Pressure Sensor

(46) Voltage supply (+5 VDC) Intake Manifold Pressure Sensor and Oil Pressure Sensor

(51) Signal (SIG) Fuel Rail Pressure Sensor

(39) Ground (GND) Oil Pressure Sensor

(47) Voltage supply (+5 VDC) Transmission Oil Pressure Sensor

(54) Signal (SIG) Transmission Oil Pressure Sensor

(40) Ground (GND) Fuel Rail Pressure Sensor

(48) Voltage supply (+5 VDC) Fuel Rail Pressure Sensor

(55) Signal (SIG) Intake Manifold Pressure Sensor

(44) Ground (GND) Transmission Oil Pressure Sensor

(56) Signal (SIG) Oil Pressure Sensor

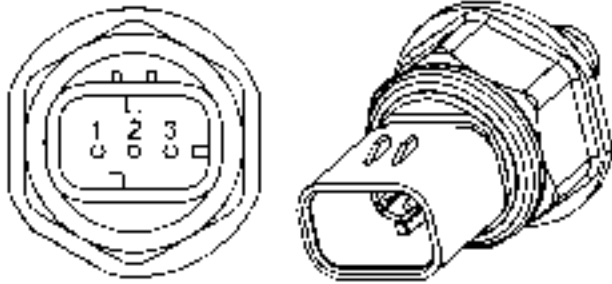

Illustration 50 g01170309
 Fuel rail pressure sensor
 (1) Voltage supply (+5 VDC)
 (2) Ground (GND)
 (3) Signal (SIG)

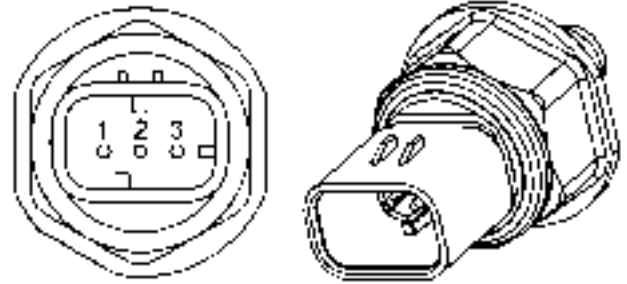

Illustration 53 g01170309
 Typical example of the fuel pressure sensor
 (1) Voltage supply (+5 VDC)
 (2) Ground (GND)
 (3) Signal (SIG)

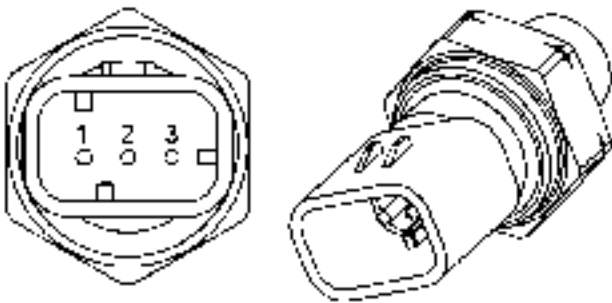

Illustration 51 g01170310
 Intake manifold pressure sensor
 (1) Voltage Supply (+5 VDC)
 (2) Ground (GND)
 (3) Signal (SIG)

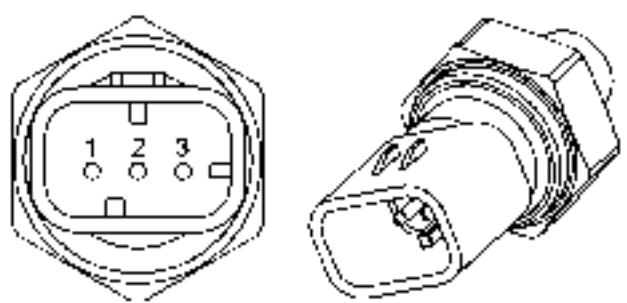

Illustration 54 g01170311
 Typical example of the transmission oil pressure sensor
 (1) Voltage Supply (+5 VDC)
 (2) Ground (GND)
 (3) Signal (SIG)

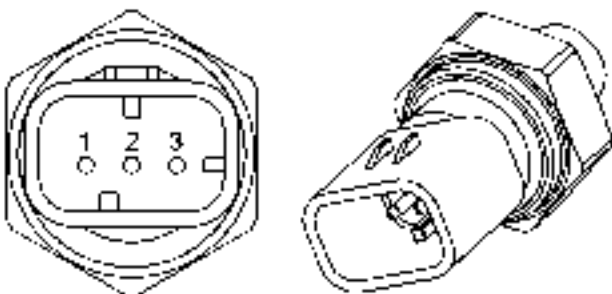

Illustration 52 g01170311
 Typical example of the oil pressure sensor
 (1) Voltage Supply (+5 VDC)
 (2) Ground (GND)
 (3) Signal (SIG)

The troubleshooting procedures for the diagnostic codes of each pressure sensor are identical. The pressure sensors are active sensors. The pressure sensor has three terminals. Active sensors require supply voltage from the ECM. The ECM connector P2/J2 supplies +5 VDC to terminal 1 of each sensor. The common line is connected to each sensor connector terminal 2. The signal voltage from terminal 3 of each sensor is supplied to the appropriate terminal at the ECM connector P2/J2.

Test Step 1. Verify All Active Diagnostic Codes

- A. Turn the keyswitch to the ON position. Wait at least 10 seconds for activation of the diagnostic codes.
- B. Verify if any of the following diagnostic codes are active:

- 0094-03 Fuel Pressure Sensor voltage above normal
- 0094-04 Fuel Pressure Sensor voltage below normal
- 0100-03 Engine Oil Pressure Sensor voltage above normal
- 0100-04 Engine Oil Pressure Sensor voltage below normal
- 0100-10 Engine Oil Pressure Sensor abnormal rate of change
- 1785-03 Intake Manifold Pressure Sensor voltage above normal
- 1785-04 Intake Manifold Pressure Sensor voltage below normal
- 1785-10 Intake Manifold Pressure Sensor abnormal rate of change
- 0127-03 Transmission Oil Pressure Sensor voltage above normal
- 0127-04 Transmission Oil Pressure Sensor voltage below normal
- 1797-03 Fuel Rail Pressure Sensor voltage above normal
- 1797-04 Fuel Rail Pressure Sensor voltage below normal

Expected Result:

One or more of the preceding diagnostic codes are active.

Results:

- OK – Proceed to Test Step 2.
- Not OK

Repair: Do not use this procedure if 1785-10 or 100-10 diagnostic codes are active. Refer to Troubleshooting, “5 Volt Sensor Supply Circuit - Test”. When this test is complete, return to the start of this test.

If the preceding codes are logged, an intermittent condition may be causing the logged codes. Refer to Troubleshooting, “Electrical Connectors - Inspect”.

Perform a “Wiggle Test” by using the electronic service tool in order to identify intermittent connections.

STOP.

Test Step 2. Inspect Electrical Connectors And Wiring

- A.** Thoroughly inspect the terminal connections on the P2/J2 ECM sensor connectors.
- B.** Thoroughly inspect the following engine pressure sensor connectors:
 - A-C5 Engine Oil Pressure Sensor
 - A-C6 Fuel Rail Pressure Sensor
 - A-C7 Intake Manifold Pressure Sensor
 - A-C14 Fuel Pressure Sensor
 - A-C18 Transmission Oil Pressure Sensor
- C.** Refer to Troubleshooting, “Electrical Connectors - Inspect”.
- D.** Perform a 45 N (10 lb) pull test on each of the wires in the ECM connector and the sensor connectors that are associated with the active diagnostic code.
- E.** Check the screw for the ECM connector for the correct torque of 5 N·m (44 lb in).
- F.** Check the harness for abrasions and for pinch points from the sensors back to the ECM.
- G.** Use the electronic service tool to perform a “Wiggle Test”. The “Wiggle Test” will identify intermittent connections.

Expected Result:

All connectors, pins, and sockets should be completely coupled and inserted. The harness should be free of corrosion, abrasions, and pinch points.

Results:

- OK – Proceed to Test Step 3.
- Not OK

Repair: Repair the connectors or the harness and/or replace the connectors or the harness. Ensure that all of the seals are correctly in place and ensure that the connectors are completely coupled.

Use the electronic service tool in order to clear all logged diagnostic codes and then verify that the repair eliminates the fault.

STOP.

Test Step 3. Verify that the Diagnostic Code is Still Active

- A. Turn the keyswitch to the ON position. Wait at least 10 seconds for activation of the diagnostic codes.
- B. Use the electronic service tool to check for active diagnostic codes. Record all active diagnostic codes.
- C. Determine if the fault is related to an open circuit diagnostic code or a short circuit diagnostic code.

Expected Result:

Either a short circuit diagnostic code is active or an open circuit diagnostic code is active.

Results:

- OK - SHORT Circuit – A “Voltage Above Normal” diagnostic code is active at this time. Proceed to Test Step 4.
- OK - OPEN Circuit – A “Voltage Below Normal” diagnostic code is active at this time. Proceed to Test Step 5.
- Not OK – A short circuit diagnostic code is not active. An open circuit diagnostic code is not active. An intermittent fault may exist.

Repair: Use the electronic service tool to perform a “Wiggle Test”. If faults are indicated then go to the appropriate procedure.

STOP.

Test Step 4. Disconnect The Sensor In Order To Create An Open Circuit

- A. Turn the keyswitch to the OFF position.
- B. Disconnect the sensor connector of the sensor with the short circuit diagnostic code.
- C. Turn the keyswitch to the ON position. Wait at least 10 seconds for activation of the diagnostic codes.
- D. Use the electronic service tool to check the “Active Diagnostic Code” screen. Check for a “Voltage Below Normal” diagnostic code.

Expected Result:

A “Voltage Below Normal” diagnostic code for the disconnected sensor is now active.

Results:

- OK – A “Voltage Above Normal” diagnostic code was active before disconnecting the sensor. An “Voltage Below Normal” diagnostic code became active after disconnecting the sensor. Proceed to Test Step 6.
- Not OK – There is a short circuit between the sensor connector on the harness and the ECM. Leave the sensor disconnected. Proceed to Test Step 8.

Test Step 5. Measure the Sensor Supply Voltage

- A. Turn the keyswitch to the OFF position.
- B. Disconnect the sensor from the engine harness.
- C. Turn the keyswitch to the ON position.
- D. Measure the voltage at the plug for the sensor from the terminal 1 (pressure sensor supply) to terminal 2 (sensor common).

Expected Result:

The DC voltage from terminal 1 to terminal 2 measures 4.84 to 5.16 VDC.

Results:

- OK – The sensor supply voltage is correct. Proceed to Test Step 7.
- Not OK – The sensor supply voltage is out of the nominal range. Continue testing the sensor supply circuit.

Repair: Proceed to the following repair: Troubleshooting, “5 Volt Sensor Supply Circuit - Test”

STOP.

Test Step 6. Determine If The Short Circuit Is In The Connector Or In The Sensor

- A. Thoroughly inspect the connector for moisture.
- B. Inspect the seals and reconnect the sensor.
- C. Refer to Troubleshooting, “Electrical Connectors - Inspect”.
- D. If the short circuit diagnostic code reappears, the sensor or the sensor connector has a fault.
 - a. Temporarily connect a new sensor to the harness, but do not install the new sensor in the engine.

- E. Use the electronic service tool to check for a short circuit diagnostic code. The new sensor should be connected to the harness at this time.

Expected Result:

The short circuit diagnostic code is not present when a new sensor is connected.

Results:

- OK – Use the electronic service tool in order to clear all logged diagnostic codes and then verify that the repair eliminates the fault. STOP.
- Not OK – Repair the engine harness connector. Use the electronic service tool to clear the logged diagnostic codes. STOP.

Test Step 7. Create a Short Circuit Between the Signal and the Common Terminals at the Engine Harness Connector

- A. Turn the keyswitch to the ON position.
- B. Fabricate a jumper wire 150 mm (6 inch) long. Crimp a terminal to both ends of the wire.
- C. Monitor the “Active Diagnostic Code” screen on the electronic service tool before installing the jumper wire and after installing the jumper wire.
- D. Install the jumper on the engine harness connector. Install one end of the jumper at the sensor signal (terminal 3). Install the other end of the jumper at the common connection for the pressure sensor (terminal 2). Wait at least 30 seconds for activation of the short circuit diagnostic code.

Expected Result:

A short circuit diagnostic code is active when the jumper is installed. An open circuit diagnostic code is active when the jumper is removed.

Results:

- OK – The engine harness and the ECM are OK.

Repair: Perform the following repair:

1. Temporarily connect the suspect sensor.
2. Use the electronic service tool to verify if the diagnostic code remains active.
3. If the diagnostic code is active replace the sensor.

4. Use the electronic service tool in order to clear all logged diagnostic codes and then verify that the repair eliminated the fault.

STOP.

- Not OK – The open circuit diagnostic code remains active when the jumper is installed. The most probable location for the open circuit is in the common wire for the sensor, or in the sensor signal wire of the engine harness between the ECM and the sensor. Remove the jumper. Proceed to Test Step 8.

Test Step 8. Check the Operation of the ECM by Creating Open and Short Circuits at the ECM Connector

- A. Turn the keyswitch to the OFF position.
- B. Disconnect connector P2 from the ECM. Thoroughly inspect both halves of the connector for signs of corrosion or moisture. Refer to Troubleshooting, “Electrical Connectors - Inspect”.
- C. Reconnect P2 connector.
- D. Turn the keyswitch to the ON position. Use the electronic service tool in order to monitor the “Active Diagnostic Code” screen. Wait at least 10 seconds for activation of the code.

An open circuit diagnostic code should be active for the suspect sensor.

Note: When the P2connector is disconnected, all of the open circuit diagnostic codes for the pressure sensors and temperature sensors will be active. This is normal. Disregard the diagnostic codes for the pressure sensors and the temperature sensors that are not suspect. Monitor the diagnostic codes for the suspect sensors only.

- E. Turn the keyswitch to the OFF position.
- F. Fabricate a jumper wire 150 mm (6 inch) long. Crimp a terminal to both ends of the wire.
- G. Install the jumper wire on the P2 connector. Insert the jumper wire between the terminal for the suspect sensor signal and the common connection for the engine's pressure sensor.

Use the electronic service tool to verify that there is a “Voltage Above Normal” diagnostic code.

Expected Result:

“Voltage Below Normal” diagnostic codes and “Voltage Above Normal” diagnostic codes were active.

Results:

- OK – The ECM is operating correctly. Proceed to Test Step 9.
- Not OK – One of the following conditions exists: The “Voltage Below Normal” diagnostic code is not active when the harness is disconnected. The “Voltage Above Normal” diagnostic code is not active when the jumper wire is installed.

Repair: Perform the following repair:

1. Make sure that the latest flash file for the application is installed in the ECM. Refer to Troubleshooting, “Flash Programming”.
2. Contact the Technical Help Desk.

Note: This consultation can greatly reduce the repair time.

3. If the Technical Help Desk recommends the use of a test ECM, install a test ECM. Refer to Troubleshooting, “Replacing the ECM”.
4. Use the electronic service tool to recheck the system for active diagnostic codes.
5. If the fault is resolved with the test ECM, reconnect the suspect ECM.
6. If the fault returns with the suspect ECM, replace the ECM.
7. Use the electronic service tool in order to clear all logged diagnostic codes and then verify that the repair eliminates the fault.

STOP.

Test Step 9. Bypass the Harness Wiring Between the ECM and the Sensor Connector

- A. Turn the keyswitch to the OFF position.
- B. Disconnect the P2 connector and disconnect the connector from the suspect sensor.
- C. Remove the sensor signal wire from the P2 connector.
- D. Remove the signal wire (terminal 3) from the sensor connector on the engine harness.
- E. Fabricate a jumper wire that is long enough to reach from the ECM to the sensor connector or use an engine sensor harness bypass with 3 terminals.

Note: If an engine sensor harness bypass is being made, crimp a socket on one end in order to connect to the ECM. Crimp either a pin or a socket on the other end, as required.

- F. Insert the one end of the engine sensor harness bypass into P2 connector on the engine harness. Insert the other end of the engine sensor harness bypass into the sensor connector of the engine harness.
- G. Reconnect the P2 connector and the sensor connector.
- H. Turn the keyswitch to the ON position.
- I. Use the electronic service tool to monitor the “Active Diagnostic Code” screen for either the open circuit diagnostic code for the sensor or the short circuit diagnostic code for the sensor.

Expected Result:

The diagnostic code disappears when the jumper or the bypass is installed.

Results:

- OK – There is a fault in the wiring harness.

Repair: Perform the following repair:

1. Repair the faulty harness or replace the faulty harness.
2. Clear all diagnostic codes.
3. Use the electronic service tool in order to clear all logged diagnostic codes and then verify that the repair eliminates the fault.

STOP.

- Not OK – The most likely cause is an intermittent fault.

Repair: Use the electronic service tool to perform a “Wiggle Test”. If no fault is found, restart this procedure and carefully perform each step.

STOP.

i04010992

Engine Speed/Timing Sensor Circuit - Test

System Operation Description:

Use this procedure to troubleshoot the system under the following conditions:

- Use this procedure if another procedure has directed you here.
- The engine will not start and the electronic service tool indicates a faulty sensor by displaying “Not Detected” against the faulty sensor on the “No Start Parameter” screen.
- There is an active diagnostic code or a recently logged diagnostic code that is related to the following:
- 0190-08 Engine Speed Sensor abnormal frequency, pulse width, or period
- 0342-08 Secondary Engine Speed Sensor abnormal frequency, pulse width, or period

The engine uses two engine speed/timing sensors. The primary sensor is located on the left-hand side of the cylinder block close to the flywheel housing. The secondary speed/timing sensor is mounted on the fuel rail pump. The primary speed/timing sensor that is mounted on the cylinder block generates a signal by detecting the movement of the teeth that are located on the timing ring. The timing ring is mounted on the crankshaft. The signal that is generated by the primary speed/timing sensor is transmitted to the Electronic Control Module (ECM). The ECM uses the signal from the sensor to calculate the position of the crankshaft. The signal is also used to determine the engine speed.

The secondary speed/timing sensor is located in the fuel rail pump. The secondary speed/timing sensor generates a signal that is related to the camshaft position. The fuel rail pump is mechanically connected to the camshaft. The secondary speed/timing sensor detects the movement of the teeth on the timing wheel in the fuel rail pump. The signal that is generated by the speed/timing sensor is transmitted to the ECM. The ECM calculates the speed and the rotational position of the engine by using the signal. The secondary speed/timing sensor is required for starting purposes.

During normal operation, the secondary speed/timing sensor is used to determine the cycle that the engine is on. When the timing has been established, the primary speed/timing sensor is then used to determine the engine speed and the angular position.

The loss of signal to the primary sensor and/or the secondary sensor will result in one of the following faults:

- The loss of signal from the secondary speed/timing sensor during start-up will prevent the engine from starting.
- The engine will continue to run when only one sensor signal is present from either the primary sensor or the secondary sensor.
- The loss of signal from the primary speed/timing sensor during operation of the engine will result in engine operation with a derate.
- Loss of signal from the primary sensor and the secondary sensor during operation of the engine will cause fuel injection to be terminated and the engine will stop.

The primary sensor and the secondary sensor are interchangeable components. If a sensor is suspect the sensors can be exchanged in order to eliminate a fault. If a secondary sensor is suspect and a replacement secondary sensor is not available, then the primary sensor and the secondary sensor can be exchanged. This will allow testing to determine if the secondary sensor is faulty.

Table 33

P2/J2 Pin Connections			
Function	Sensor Pin	Primary Sensor	Secondary Sensor
+8 Volt Supply	1	10	10
Signal	2	52	53

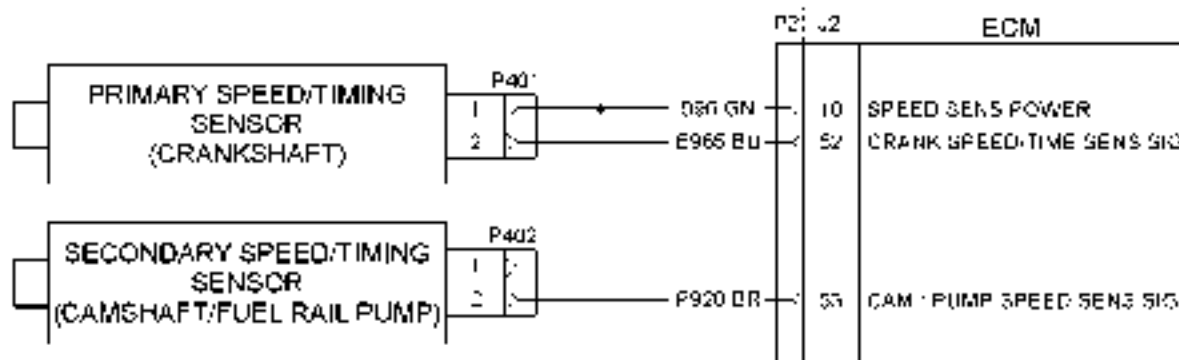

Illustration 55

g01803493

The schematic for the speed/timing sensors

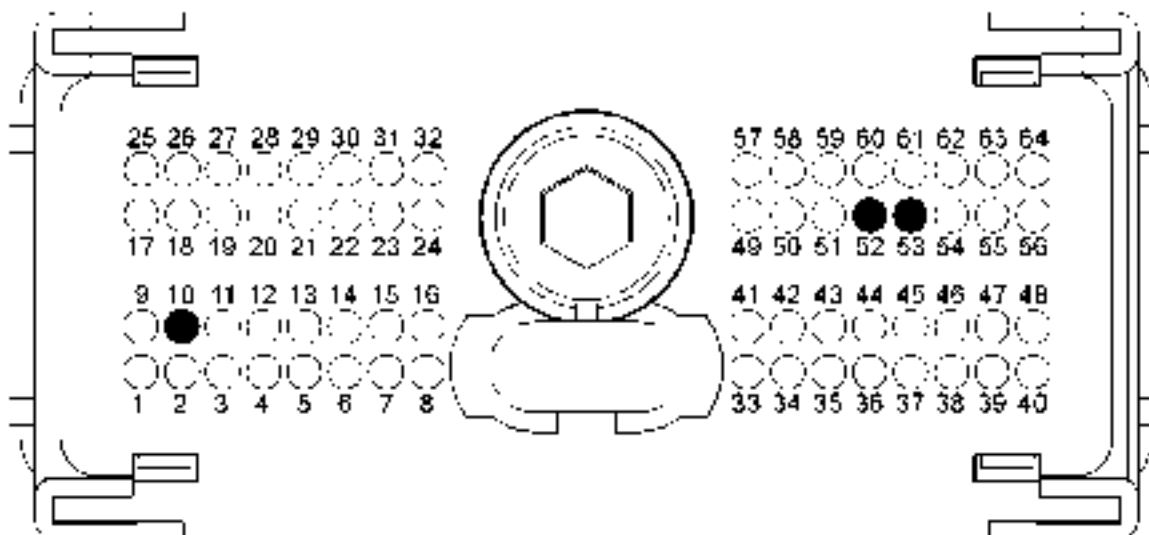

Illustration 56

g01803494

Pin locations on the P2 connector for the speed/timing sensors

- (10) Speed/timing sensor supply (+8 Volts DC)
- (52) Primary speed/timing sensor signal
- (53) Secondary speed/timing sensor signal



Illustration 57

Detailed view of the sensor locations on the engine

(1) Primary speed/timing sensor

(2) Secondary speed/timing sensor

g01803516

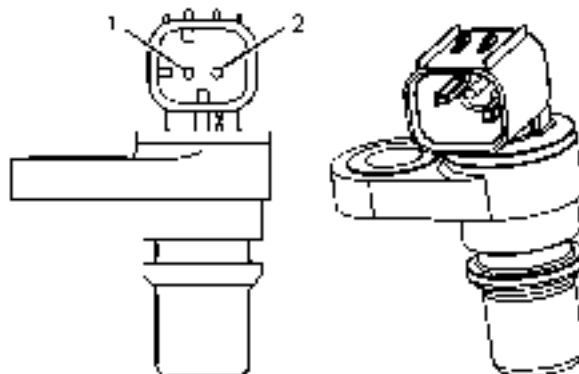

Illustration 58

Typical example of the speed/timing sensors

(1) Voltage Supply (+8 Volts DC)

(2) Signal (Sig)

g01212995

Test Step 1. Inspect the Electrical Connectors and the Harness

- A. Turn the keyswitch to the OFF position.
- B. Thoroughly inspect the P2 connector and the suspect sensor connections. Refer to Troubleshooting, "Electrical Connectors - Inspect".
- C. Perform a 45 N (10 lb) pull test on each of the wires in the suspect sensor connector and the sensor connections at the ECM. The wire connectors are shown in illustration 56.
- D. Check that the ground connection on the ECM and the negative terminal on the battery are correctly installed.
- E. Check the ground connection on the ECM for abrasions and pinch points.
- F. Check the screw for the ECM connector for the correct torque of 5.0 N·m (44 lb in).
- G. Check the harness for abrasion and pinch points from the suspect sensor to the ECM.

- H. Check that the suspect sensor is installed correctly. Check that the suspect sensor is fully seated into the engine. Check that the connector on the sensor is securely latched.

Expected Result:

The electrical connectors and the cables are correctly installed.

Results:

- OK – The harness is OK. Proceed to Test Step 2.
- Not OK

Repair: Repair the faulty connectors or the harness and/or replace the faulty connectors or the harness. Ensure that all of the seals are correctly in place and ensure that the connectors are correctly coupled.

If a sensor must be replaced or the sensor must be reinstalled, complete all of the following tasks:

- Lubricate the “O” ring with clean engine lubricating oil.
- Ensure that the plug for the sensor has a seal inside the connector body. If a seal is damaged or missing, replace the seal.
- Ensure that the sensor is fully seated into the engine before tightening the bracket bolt.
- Ensure that the connector is latched.
- Ensure that the harness is correctly secured, and ensure that the harness is attached to the harness clip.

Use the electronic service tool in order to clear all logged diagnostic codes and then verify that the repair has eliminated the fault.

STOP.

Test Step 2. Check for Active Diagnostic Codes and Recently Logged Diagnostic Codes

- Turn the keyswitch to the OFF position.
- Connect the electronic service tool to the diagnostic connector.
- Turn the keyswitch to the ON position. If the engine will start, then run the engine.
- Use the electronic service tool in order to monitor active diagnostic codes or recently logged diagnostic codes.

Expected Result:

One or more of the following diagnostic codes are active or recently logged:

- 190-8 Engine Speed Sensor abnormal frequency, pulse width, or period
- 342-8 Secondary Engine Speed Sensor abnormal frequency, pulse width, or period

Results:

- 190-8 – Proceed to Test Step 4.
- 342-8 – Proceed to Test Step 3.
- Not OK – No active diagnostic codes or recently logged diagnostic codes are displayed. STOP.

Test Step 3. Check the Harness Between the Secondary Speed/Timing Sensor and the ECM

- Turn the keyswitch to the OFF position.

- Disconnect the P2 connector. Disconnect the connector for the primary speed/timing sensor. Disconnect the connector for the secondary speed/timing sensor.
- Check the resistance between P2:53 and terminal 2 on the secondary speed/timing sensor. The resistance should be less than 2.0 Ohms.
- Check the resistance between P2:10 and terminal 1 on the secondary speed/timing sensor. The resistance should be less than 2.0 Ohms.

Expected Result:

The readings agree with the values that are listed above.

Results:

- OK – The harness does not have an open circuit. Proceed to Test Step 5.
- Not OK – The harness or the connector has an open circuit or high resistance.

Repair: Repair the faulty connectors or the harness. Replace the faulty connectors or the harness. Reconnect all sensor and ECM connectors. Ensure that all of the seals are correctly in place. Ensure that all connectors are correctly coupled.

Use the electronic service tool in order to clear all logged diagnostic codes and then verify that the repair has eliminated the fault.

STOP.

Test Step 4. Check the Harness Between the Primary Speed/Timing Sensor and the ECM

- Turn the keyswitch to the OFF position.
- Disconnect the P2 connector. Disconnect the connector for the primary speed/timing sensor. Disconnect the connector for the secondary speed/timing sensor.
- Check the resistance between P2:52 and terminal 2 on the secondary speed/timing sensor. The resistance should be less than 2.0 Ohms.
- Check the resistance between P2:10 and terminal 1 on the secondary speed/timing sensor. The resistance should be less than 2.0 Ohms.

Expected Result:

The readings agree with the values that are listed above.

Results:

- OK – The harness does not have an open circuit. Proceed to Test Step 6.
- Not OK – The harness has an open circuit.

Repair: Repair the faulty connectors or the harness and/or replace the faulty connectors or the harness. Reconnect all sensor and ECM connectors. Ensure that all of the seals are correctly in place. Ensure that all connectors are correctly coupled.

Use the electronic service tool in order to clear all logged diagnostic codes and then verify that the repair eliminates the fault.

STOP.

Test Step 5. Check that the Connections and the Wiring to the Secondary Speed/Timing Sensor and the ECM are Isolated from Other Power Sources

- Turn the keyswitch to the OFF position.
- Disconnect the P2 connector. Disconnect the connector for the primary speed/timing sensor. Disconnect the connector for the secondary speed/timing sensor.
- Measure the resistance from P2:53 to all other pins on the P2 connector. Measure the resistance from P2:53 to the ground and battery+ terminals. The resistance should be more than 20,000 Ohms.
- Measure the resistance from P2:10 to all other pins on the P2 connector. Measure the resistance from P2:10 to the ground and the battery+ terminals. The resistance should be more than 20,000 Ohms.

Expected Result:

The readings agree with the values that are listed above.

Results:

- OK – There is no short circuit. Proceed to Test Step 7.
- Not OK – The harness has a short circuit.

Repair: Repair the faulty connectors or replace the faulty connectors. Repair the faulty harness or replace the faulty harness. Reconnect all sensor and ECM connectors. Ensure that all of the seals are correctly in place. Ensure that all connectors are correctly coupled.

Use the electronic service tool in order to clear all logged diagnostic codes and then verify that the repair eliminates the fault.

STOP.

Test Step 6. Check that the Connections and the Wiring to the Primary Speed/Timing Sensor and the ECM are Isolated from the Other Power Sources

- Turn the keyswitch to the OFF position.
- Disconnect the P2 connector. Disconnect the connector from the primary speed/timing sensor. Disconnect the connector from the secondary speed/timing sensor.
- Check the resistance between P2:52 and each of the other pins on the P2 connector. Check the resistance between P2:52 and the ground and battery+ terminals. The resistance should be more than 20,000 Ohms.
- Check the resistance between P2:10 and each of the other pins on the P2 connector. Check the resistance between P2:10 and the ground and battery+ terminals. The resistance should be more than 20,000 Ohms.

Expected Result:

The readings agree with the values that are listed above.

Results:

- OK – The wires are not a short circuit. Proceed to Test Step 7.
- Not OK – The sensor wiring has a short circuit.

Repair: Repair the faulty connectors or replace the faulty connectors. Repair the faulty harness or replace the faulty harness. Reconnect all sensor and ECM connectors. Ensure that all of the seals are correctly in place. Ensure that all connectors are correctly coupled.

Use the electronic service tool in order to clear all logged diagnostic codes and then verify that the repair eliminates the fault.

STOP.

Test Step 7. Check if a Replacement Sensor Eliminates the Fault

- Turn the keyswitch to the OFF position.
- Disconnect the suspect sensor and remove the suspect sensor from the engine.

C. If a sensor must be replaced or a sensor must be reinstalled, complete all of the following tasks:

- Lubricate the “O” ring with clean engine lubricating oil.
- Ensure that the plug for the sensor has a seal inside the connector body. If a seal is damaged or missing, replace the seal.
- Ensure that the sensor is fully seated into the engine before tightening the bracket bolt.
- Ensure that the connector is latched.
- Ensure that the harness is correctly secured, and ensure that the harness is attached to the harness clip.

D. Turn the keyswitch to the ON position.

E. Start the engine.

F. Use the electronic service tool in order to monitor the diagnostic codes.

G. Use the electronic service tool in order to clear all logged diagnostic codes and then verify that the replacement sensor has eliminated the fault.

Expected Result:

The fault has been rectified.

Results:

- OK – If the fault is eliminated with the replacement sensor, reconnect the suspect sensor. If the fault returns with the suspect sensor, replace the suspect sensor.

Repair: Use the electronic service tool in order to clear all logged diagnostic codes and then verify that the repair eliminates the fault.

STOP.

- Not OK – The fault still exists. Proceed to Test Step 8.

Test Step 8. Check if the Replacement of the ECM Eliminates the Fault

A. Make sure that the latest flash file for the application is installed in the ECM. Refer to Troubleshooting, “Flash Programming”.

B. Contact the Technical Help Desk.

Note: This consultation can greatly reduce the repair time.

C. If the Technical Help Desk recommends the use of a test ECM, install a test ECM. Refer to Troubleshooting, “Replacing the ECM”.

D. Connect the electronic service tool to the diagnostic connector.

E. Turn the keyswitch to the ON position.

F. Start the engine.

G. Use the electronic service tool to recheck the system for active diagnostic codes.

Expected Result:

The fault is eliminated.

Results:

- OK

Repair: If the fault is eliminated with the test ECM, perform the following procedure:

1. Reconnect the suspect ECM.
2. If the fault returns with the suspect ECM, replace the ECM.
3. Use the electronic service tool in order to clear all logged diagnostic codes and then verify that the repair eliminates the fault.

STOP.

- Not OK – The fault was not eliminated with a test ECM.

Repair: Install the original ECM.

1. If the fault persists, the fault may be a damaged timing ring. Check the timing ring and/or replace the timing ring.
2. If the fault is not eliminated, repeat the diagnostic procedure from Step 1.

STOP.

i04022111

Engine Temperature Sensor Open or Short Circuit - Test

System Operation Description:

Use this procedure under the following conditions:

This procedure covers open circuit diagnostic codes and short circuit diagnostic codes that are associated with the following sensors:

- Coolant temperature sensor
- Intake manifold air temperature sensor
- Fuel temperature sensor
- Transmission oil temperature sensor

Use this procedure to troubleshoot the system when one of the following diagnostic codes is an active diagnostic code or a recently logged diagnostic code or when a diagnostic code can easily be activated.

- 0110-03 Engine Coolant Temperature Sensor voltage above normal
- 0110-04 Engine Coolant Temperature Sensor voltage below normal
- 0174-03 Fuel Temperature Sensor voltage above normal
- 0174-04 Fuel Temperature Sensor voltage below normal
- 0177-03 Transmission Oil Temperature Sensor voltage above normal
- 0177-04 Transmission Oil Temperature Sensor voltage below normal
- 0172-03 Intake Manifold Air Temperature Sensor voltage above normal
- 0172-04 Intake Manifold Air Temperature Sensor voltage below normal

The following background information is related to this procedure:

The troubleshooting procedures for the diagnostic codes of each temperature sensor are identical. The temperature sensors are sensors that have two terminals. P2:37 on the Electronic Control Module (ECM) is the common connection for the engine temperature sensors. The sensor common connection is shared between the temperature sensors. The common line is connected to terminal 2 on each sensor connector. Terminal 1 is the sensor output. The signal voltage from terminal 1 of each sensor is supplied to the appropriate terminal at ECM Connector P2/J2.

Pull-up Voltage

The ECM continuously outputs a pull-up voltage on the circuit for the sensor signal wire. The ECM uses this pull-up voltage in order to detect an open in the signal circuit. When the ECM detects the presence of a voltage that is above a threshold on the signal circuit, the ECM will generate an open circuit FMI code (-03) for the sensor.

If the sensor is disconnected at the sensor connector, the presence of pull-up voltage at the sensor connector indicates that the wires from the sensor connector to the ECM are not open or shorted to ground. If the sensor is disconnected at the sensor connector, the absence of pull-up voltage at the sensor connector indicates an open in the signal wire or a short to ground. If the sensor is disconnected at the sensor connector and the voltage at the sensor connector is different from pull-up voltage, the signal wire is shorted to another wire in the harness.

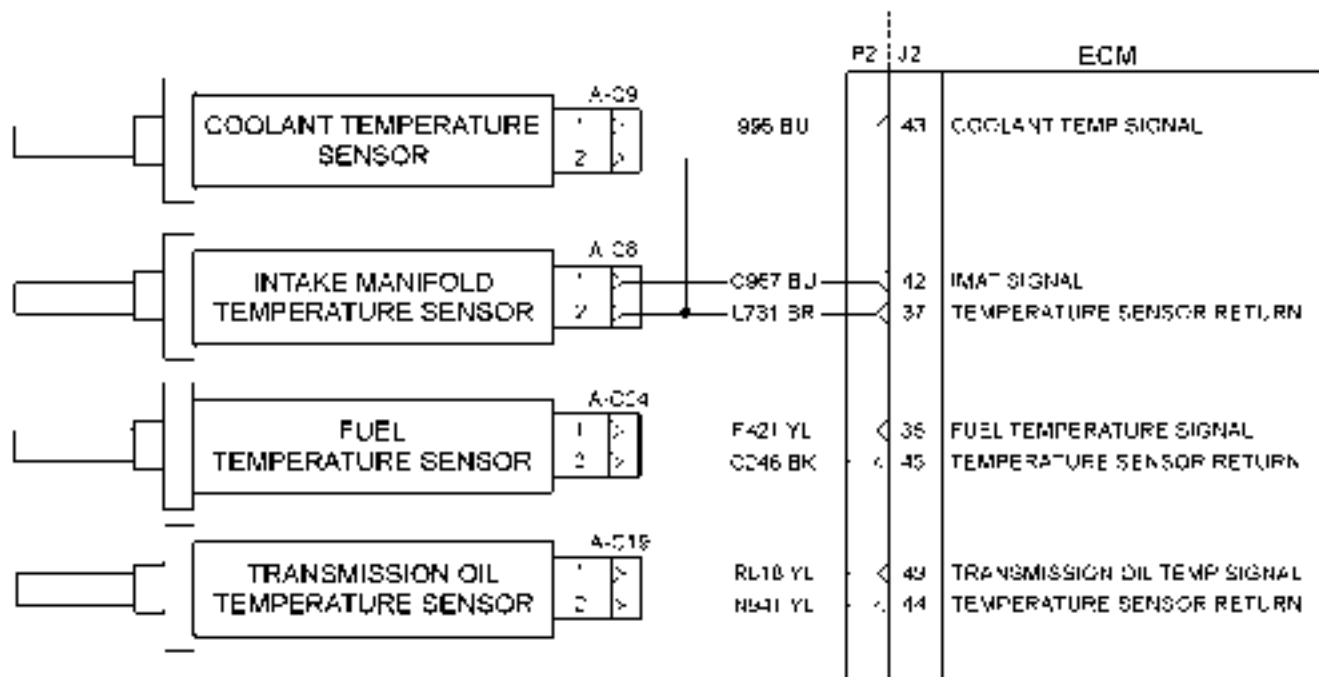

Illustration 59

g02199533

Schematic for the temperature sensors

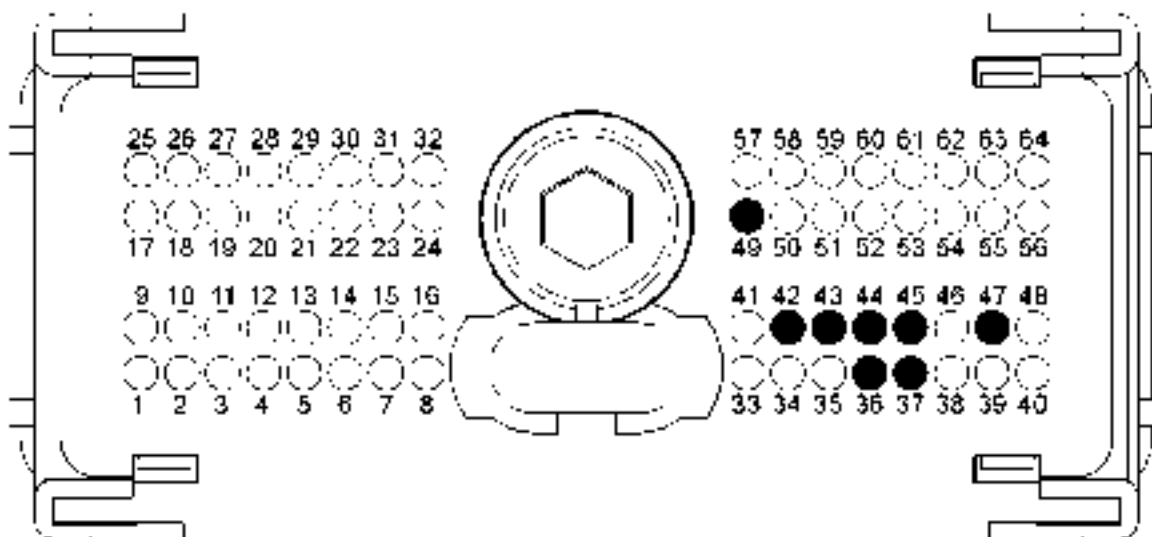

Illustration 60

g02199533

Typical view of the P2 pin locations for the temperature sensors

- (36) Signal (SIG) Fuel Temperature Sensor
- (37) Ground (GND) Intake Manifold Air Temperature Sensor and Coolant Temperature Sensor
- (42) Signal (SIG) Intake Manifold Air Temperature Sensor

- (43) Signal (SIG) Coolant Temperature Sensor
- (44) Ground (GND) Transmission Oil Temperature Sensor
- (45) Ground (GND) Fuel Temperature Sensor

- (49) Signal (SIG) Transmission Oil Temperature Sensor

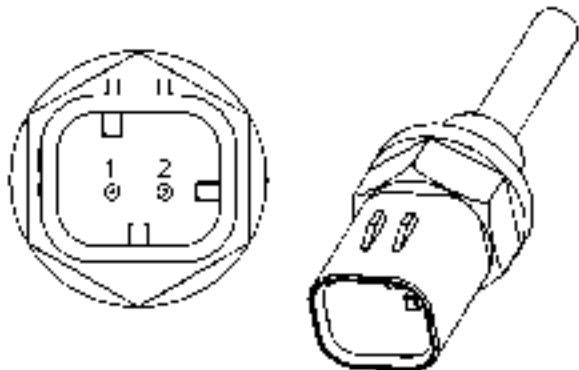

Illustration 61

g01170313

Typical example of a temperature sensor

- (1) Signal (SIG)
- (2) Ground (GND)

Test Step 1. Verify All Active Diagnostic Codes

A. Connect the electronic service tool to the diagnostic connector.

B. Turn the keyswitch to the ON position.

Note: Wait at least 30 seconds for activation of the diagnostic codes.

C. Use the electronic service tool in order to verify if any of the following diagnostic codes are active or recently logged:

- 0110-03 Engine Coolant Temperature Sensor voltage above normal
- 0110-04 Engine Coolant Temperature Sensor voltage below normal
- 0174-03 Fuel Temperature Sensor voltage above normal
- 0174-04 Fuel Temperature Sensor voltage below normal
- 0177-03 Transmission Oil Temperature Sensor voltage above normal
- 0177-04 Transmission Oil Temperature Sensor voltage below normal
- 0172-03 Intake Manifold Air Temperature Sensor voltage above normal
- 0172-04 Intake Manifold Air Temperature Sensor voltage below normal

Expected Result:

One or more of the preceding diagnostic codes are active or recently logged.

Results:

- Yes – Proceed to Test Step 2.
- No – The fault is intermittent. Proceed to Test Step 8.

Test Step 2. Inspect Electrical Connectors And Wiring

A. Thoroughly inspect ECM engine harness connector P2 and the suspect sensor connector. Refer to Troubleshooting, “Electrical Connectors - Inspect”.

B. Perform a 45 N (10 lb) pull test on each of the wires in the sensor connector and the ECM connector that are associated with the active diagnostic code.

C. Verify that the latch tab of the connector is correctly latched. Also verify that the latch tab of the connector has returned to the fully latching position.

D. Check the screw for the ECM connector for the correct torque of 5.0 N·m (44 lb in).

E. Check the harness for abrasions and for pinch points from the sensor to the ECM.

Expected Result:

All connectors, pins, and sockets should be completely coupled and/or inserted. The harness should be free of corrosion, abrasion, and pinch points.

Results:

- OK – Proceed to Test Step 3.
- Not OK – Repair the connectors or the harness and/or replace the connectors or the harness. Ensure that all of the seals are correctly in place and ensure that the connectors are completely coupled. Clear all inactive diagnostic codes. Verify that the repair has eliminated the fault. Proceed to Test Step 3 if the fault has not been eliminated.

Test Step 3. Verify That The Diagnostic Code Is Still Active

A. Turn the keyswitch to the ON position.

Note: Wait at least 10 seconds for activation of the diagnostic codes.

B. Access the “Active Diagnostic Code” screen on the electronic service tool and check for active diagnostic codes.

C. Determine if the fault is related to an “Voltage Above Normal” diagnostic code or a “Voltage Below Normal” diagnostic code.

Expected Result:

A “Voltage Below Normal” diagnostic code or an “Voltage Above Normal” diagnostic code is active.

Results:

- OK - SHORT Circuit – A “Voltage Below Normal” diagnostic code is active at this time. Proceed to Test Step 4.
- OK - OPEN Circuit – A “Voltage Above Normal” diagnostic code is active at this time. Proceed to Test Step 5.
- Not OK – A “Voltage Below Normal” diagnostic code is not active. An “Voltage Above Normal” diagnostic code is not active. An intermittent fault may exist.

Repair: Use the electronic service tool to perform a “Wiggle Test”. If faults are indicated then go to the appropriate procedure.

STOP.

Test Step 4. Disconnect The Sensor In Order To Create An Open Circuit

- A.** Turn the keyswitch to the OFF position.
- B.** Disconnect the connector for the sensor with the short circuit diagnostic code.
- C.** Turn the keyswitch to the ON position.

Note: Wait at least 10 seconds for activation of the diagnostic codes.

- D.** Access the “Active Diagnostic Code” screen of the electronic service tool. Check for an active “Voltage Above Normal” diagnostic code.

Expected Result:

A “Voltage Above Normal” diagnostic code for the disconnected sensor is now active.

Results:

- OK – A “Voltage Below Normal” diagnostic code was active before disconnecting the sensor. An “Voltage Above Normal” diagnostic code became active after disconnecting the sensor.

Repair: Refer to Troubleshooting, “Electrical Connectors - Inspect”.

Inspect the seals in the connectors for damage.

Connect the sensor and verify that the fault returns. If the fault returns, the sensor is faulty.

Replace the sensor.

Clear all logged diagnostic fault codes.

STOP.

- Not OK – There is a short circuit between the sensor harness connector and the ECM. Leave the sensor disconnected. Proceed to Test Step 6.

Test Step 5. Create A Short Circuit Between The Signal And The Common Terminals At The Sensor Harness Connector

- A.** Disconnect the suspect sensor connector A-C9 for the coolant temperature sensor or disconnect A-C8 for the inlet manifold temperature sensor. Disconnect the suspect sensor connector A-C24 for the fuel temperature sensor or disconnect A-C19 for the transmission oil temperature sensor.

- B.** Turn the keyswitch to the ON position.

Note: Wait at least 10 seconds for the activation of any diagnostic fault codes.

- C.** Fabricate a jumper wire 150 mm (6 inch) long. Crimp a terminal to both ends of the wire.
- D.** Monitor the “Active Diagnostic Code” screen on the electronic service tool before installing the jumper wire and after installing the jumper wire.
- E.** Install the jumper on the engine harness connector for the suspect sensor, A-C9 for the coolant temperature sensor and A-C8 for the intake manifold temperature sensor. Install the jumper on the engine harness connector for the suspect sensor, A-C24 for the fuel temperature sensor and A-C19 for the transmission oil temperature sensor. Install one end of the jumper at the sensor signal (terminal 1). Install the other end of the jumper at the common connection (terminal 2).

Note: Wait at least 30 seconds for activation of the short circuit diagnostic code.

Expected Result:

A “Voltage Below Normal” diagnostic code is active when the jumper is installed. An “Voltage Above Normal” diagnostic code is active when the jumper is removed.

Results:

- OK – The engine harness and the ECM are OK.

Repair: Perform the following repair:

1. Temporarily connect the suspect sensor.
2. If the diagnostic code remains active, replace the sensor.
3. Verify that the repair eliminates the fault.
4. Clear all logged diagnostic codes.

STOP.

- Not OK – The “Voltage Above Normal” diagnostic code remains active with the jumper in place. The most probable location for the open circuit is in the sensor common or the sensor signal wire in the engine harness between the ECM and the sensor. Remove the jumper. Proceed to Test Step 6.

Test Step 6. Check The Operation Of The ECM By Creating An Open And A Short Circuit At The ECM Connector

- A. Turn the keyswitch to the OFF position.
- B. Disconnect the P2 connector.
- C. Thoroughly inspect both halves of the connector for signs of corrosion or moisture. Refer to Troubleshooting, “Electrical Connectors - Inspect”.
- D. Turn the keyswitch to the ON position. Use the electronic service tool in order to monitor the “Active Diagnostic Code” screen. Wait at least 10 seconds for activation of the code.

An “Voltage Above Normal” diagnostic code should be active for the suspect sensor.

Note: When P2 is disconnected, all of the “Voltage Above Normal” diagnostic codes for the pressure sensors and temperature sensors will be active. This is normal. Disregard the diagnostic codes for the pressure sensors and the temperature sensors that are not suspect. Monitor the diagnostic codes for the suspect sensors only.

- E. Turn the keyswitch to the OFF position.
- F. Fabricate a jumper wire 150 mm (6 inch) long. Crimp a terminal to both ends of the wire.
- G. Monitor the “Active Diagnostic Code” screen on the electronic service tool before installing the jumper wire and after installing the jumper wire.

- H. Remove the suspect sensor signal pin from the P2 connector, either pin P2:42 for the intake manifold temperature sensor or pin P2:43 for the coolant temperature sensor. Remove the P2:37 sensor common connector. Install the jumper on the P2 connector. Install one end of the jumper at the suspect sensor signal pin. Install the other end of the jumper to the P2:37 common connection for the sensors. Reassemble the P2 connector to the ECM. Use the electronic service tool in order to check the diagnostic codes. Wait at least 10 seconds for activation of the “Voltage Below Normal” diagnostic code.

Note: The “Voltage Above Normal” diagnostic code for the temperature sensor that is not suspect should become active when the sensor common connection is removed from the P2 connector. This code can be disregarded.

Expected Result:

A “Voltage Below Normal” diagnostic code is active when the jumper is installed. A “Voltage Above Normal” diagnostic code is active when the jumper is removed.

Results:

- OK – Proceed to test step 7.
- Not OK

Repair: The ECM does not operate correctly. Perform the following repair:

1. Make sure that the latest flash file for the application is installed in the ECM. Refer to Troubleshooting, “Flash Programming”.
2. Contact the Technical Help Desk.

Note: This consultation can greatly reduce the repair time.

3. If the Technical Help Desk recommends the use of a test ECM, install a test ECM. Refer to Troubleshooting, “Replacing the ECM”.
4. Use the electronic service tool to recheck the system for active diagnostic codes.
5. If the fault is resolved with the test ECM, reconnect the suspect ECM.
6. If the fault returns with the suspect ECM, replace the ECM.
7. Use the electronic service tool in order to clear all logged diagnostic codes and then verify that the repair eliminates the fault.

STOP.

Test Step 7. Bypass The Harness Wiring Between The ECM And The Sensor Connector

- A. Turn the keyswitch to the OFF position.
- B. Disconnect the P2 connector on the ECM harness, and the suspect sensor connector.
- C. Remove the sensor signal wire from the P2 connector.
- D. Remove the signal wire (terminal 1) from the sensor connector on the engine harness.
- E. Fabricate a jumper wire that is long enough to reach from the ECM to the sensor connector with sockets on both ends.
- F. Insert one end of the jumper into the ECM connector. Insert the other end of the jumper into the sensor connector of the engine harness.
- G. Reconnect the connector for the ECM harness and the sensor connector.
- H. Turn the keyswitch to the ON position.
- I. Use the electronic service tool in order to monitor the "Active Diagnostic Code" screen for either the "Voltage Above Normal" diagnostic code for the sensor or the "Voltage Below Normal" diagnostic code for the sensor.

Expected Result:

The diagnostic code disappears when the jumper is installed.

Results:

- OK – There is a fault in the wiring harness.

Repair: Perform the following repair:

1. Repair the faulty harness or replace the faulty harness.
2. Clear all diagnostic codes.
3. Use the electronic service tool in order to clear all logged diagnostic codes and then verify that the repair eliminates the fault.

STOP.

- Not OK – The fault is intermittent. Proceed to Test Step 8.

Test Step 8. Perform the "Wiggle Test" on the Perkins Electronic Service Tool (EST)

- A. Select the "Wiggle Test" from the diagnostic tests on the electronic service tool.
- B. Choose the appropriate group of parameters to monitor.
- C. Press the "Start" button. Wiggle the wiring harness in order to reproduce intermittent faults.

If an intermittent fault exists, the status will be highlighted and an audible beep will be heard.

Expected Result:

No intermittent faults were indicated during the "Wiggle Test".

Results:

- OK – No intermittent faults were found. The harness and connectors appear to be OK. If this test was required as part of another procedure, return to that procedure and continue testing. If this test has resolved the fault, return the engine to service. STOP.
- Not OK – At least one intermittent fault was indicated.

Repair: Repair the harness or the connector.

Use the electronic service tool in order to clear all logged diagnostic codes and then verify that the repair eliminates the fault.

STOP.

i04019619

Engine Temperature Sensor Open or Short Circuit - Test

System Operation Description:

This test procedure is used for the active temperature sensor. The active sensor has a three-wire electrical connector.

Use this procedure under the following conditions:

Use this procedure if another procedure has directed you here. Use this procedure if any of the following diagnostic codes are active:

- 0535-03 Exhaust Gas Temperature Sensor voltage above normal

- 0535-04 Exhaust Gas Temperature Sensor voltage below normal

Pull-up Voltage

The ECM continuously outputs a pull-up voltage on the circuit for the sensor signal wire. The ECM uses this pull-up voltage in order to detect an open in the signal circuit. When the ECM detects the presence of a voltage that is above a threshold on the signal circuit, the ECM will generate an open circuit diagnostic code -3 for the sensor.

If the sensor is disconnected at the sensor connector, the presence of pull-up voltage at the sensor connector indicates that the wires from the sensor connector to the ECM are not open or shorted to ground. If the sensor is disconnected at the sensor connector, the absence of pull-up voltage at the sensor connector indicates an open in the signal wire or a short to ground. If the sensor is disconnected at the sensor connector and the voltage at the sensor connector is different from pull-up voltage, the signal wire is shorted to another wire in the harness.

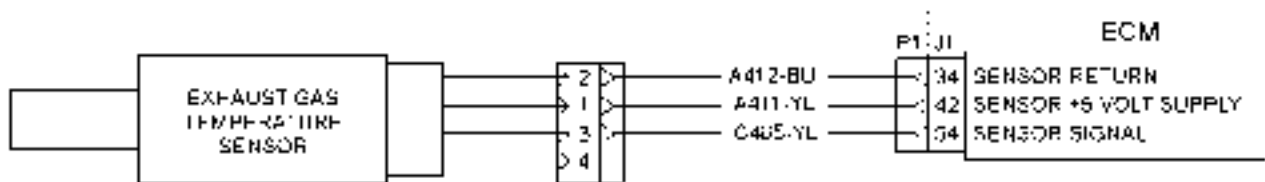

Illustration 62

g02193015

Schematic for exhaust gas temperature sensor



Illustration 63

g01159881

Typical example of an exhaust gas temperature sensor connector

- (A) Sensor +5 Volt supply
- (B) Sensor return
- (C) Sensor signal

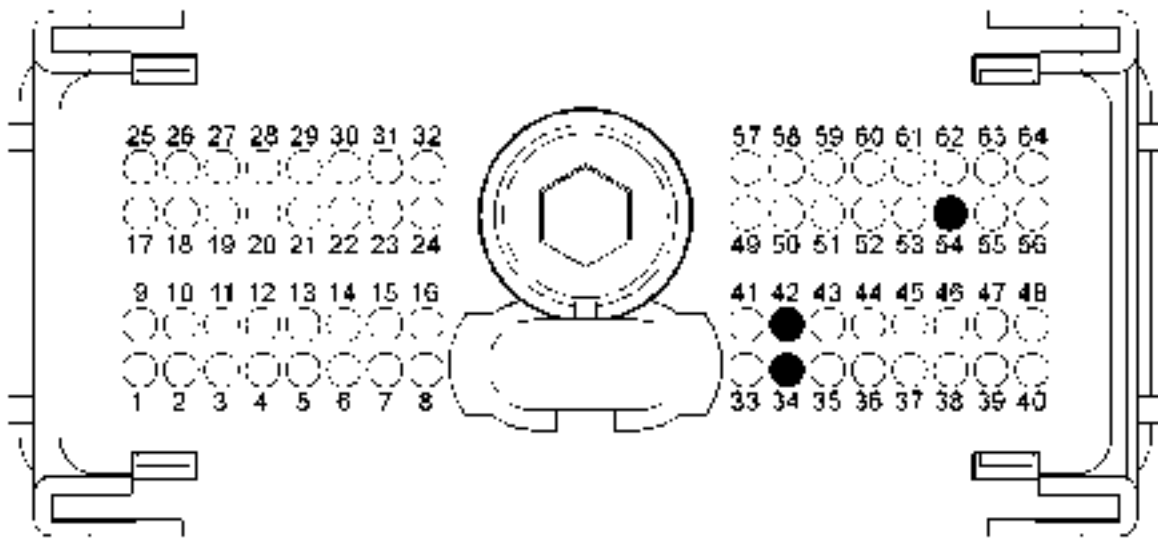

Illustration 64

g02193016

A typical view of the P1 connector pin locations.

(34) Sensor return

(42) Sensor +5 Volt supply

(54) Sensor signal

Test Step 1. Inspect Electrical Connectors And Wiring

- A. Remove the electrical power from the ECM.
- B. Thoroughly inspect the ECM engine harness connector and the connector for the fuel temperature sensor. Refer to Troubleshooting, "Electrical Connectors - Inspect".
- C. Perform a 45 N (10 lb) pull test on each of the wires that are associated with the fuel temperature sensor.
- D. Verify that the latch tab of the connector is correctly latched.
- E. Check the allen head screws for each ECM connector for the proper torque. Refer to Troubleshooting, "Electrical Connectors - Inspect" for the correct torque values.
- F. Check the harness for abrasions, for pinch points, and for corrosion.

Expected Result:

All connectors, pins, and sockets are completely coupled and/or inserted. The harness is free of corrosion, of abrasion, and of pinch points.

Results:

- OK – The connectors and wiring appear to be OK. Proceed to Test Step 2.

- Not OK – There is a fault in the connectors and/or wiring.

Repair: Repair the connectors or wiring and/or replace the connectors or wiring. Ensure that all of the seals are correctly installed and ensure that the connectors are completely coupled.

If necessary, perform the "Wiggle Test" on the electronic service tool.

Use the electronic service tool in order to clear all logged diagnostic codes and then verify that the repair eliminates the fault.

STOP.

Test Step 2. Check the Supply Voltage at the Sensor Connector

- A. Remove the electrical power from the ECM.
- B. Disconnect the harness connector for the exhaust gas temperature sensor.
- C. Restore the electrical power to the ECM.
- D. Measure the voltage between terminals A (+5 Volts DC) and B (Return) at the sensor connector on the engine harness.
- E. Remove the electrical power from the ECM.
- F. Reconnect the sensor.

Expected Result:

The voltage measurement is 5.0 ± 0.2 Volts DC.

Results:

- OK – The voltage measurement is 5.0 ± 0.2 Volts DC. Proceed to Test Step 3.
- Not OK – The voltage measurement is not 5.0 ± 0.20 Volts DC.

Repair: The correct voltage is not reaching the sensor. Refer to Troubleshooting, "Speed Control (PWM) - Test".

STOP.

Test Step 3. Check for Active and/or Logged Diagnostic Codes

- A. Connect the electronic service tool to the service tool connector.
- B. Restore the electrical power to the ECM.
- C. Monitor the active diagnostic code screen on the electronic service tool. Check and record any active diagnostic codes.

Note: Wait at least 30 seconds in order for the diagnostic codes to become active.

Note: A diagnostic code that is logged several times is an indication of an intermittent problem. Most intermittent problems are the result of a poor connection between a socket and a pin in a connector or of a poor connection between a wire and a terminal.

- D. Look for a 0535-3 diagnostic code or a 0535-4 diagnostic code.

Expected Result:

No diagnostic codes are active.

Results:

- OK – No diagnostic codes are active. The problem appears to be resolved.

Repair: The problem may have been intermittent. Carefully reinspect the connectors and wiring. Refer to Troubleshooting, "Electrical Connectors - Inspect".

STOP.

- Not OK – A 0535-4 diagnostic code is active at this time. Proceed to Test Step 4.

- Not OK – A 0535-3 diagnostic code is active at this time. Proceed to Test Step 5.

Test Step 4. Disconnect the Sensor in Order to Create an Open Circuit

- A. Remove the electrical power from the ECM.
- B. Disconnect the sensor from the engine harness.
- C. Restore the electrical power to the ECM. Wait at least 30 seconds for activation of the diagnostic codes.
- D. Access the "Active Diagnostic Codes" screen on the electronic service tool and check for an active 0535-3 diagnostic code for the suspect sensor.
- E. Remove the electrical power from the ECM.

Expected Result:

A 0535-3 diagnostic code is now active for the sensor.

Results:

- OK – A 0535-4 diagnostic code was active before disconnecting the sensor. A 0535-3 diagnostic code became active after the sensor was disconnected. There may be a problem with the sensor.

Repair: Temporarily connect a new sensor to the harness, but do not install the new sensor in the engine. Use the electronic service tool in order to verify that the repair eliminates the fault. If there are no active diagnostic codes for the sensor, permanently install the new sensor.

Use the electronic service tool in order to clear all logged diagnostic codes and then verify that the repair eliminates the fault.

STOP.

- Not OK – The 0535-4 diagnostic code is still present. Leave the sensor disconnected. Proceed to Test Step 7.

Test Step 5. Check the Signal Wire for a Short Circuit

- A. Remove the electrical power from the ECM.
- B. Disconnect the P1 ECM connector.
- C. Disconnect the harness connector for the exhaust gas temperature sensor.
- D. Measure the resistance between terminal P1-54 and the remaining terminals on the ECM connector.

E. Connect the P1 ECM connector. Connect the connector for the exhaust gas temperature sensor.

Expected Result:

Each resistance measurement indicates an open circuit.

Results:

- OK – Each resistance measurement indicates an open circuit. Proceed to Test Step 6.
- Not OK – At least one resistance measurement does not indicate an open circuit.

Repair: There is a short circuit in the harness. Repair the harness or replace the harness.

If necessary, perform the “Wiggle Test” on the electronic service tool.

Use the electronic service tool in order to clear all logged diagnostic codes and then verify that the repair eliminates the fault.

STOP.

Test Step 6. Create a Short at the Sensor Connector

- A. Disconnect the exhaust gas temperature sensor at the sensor connector.
- B. Fabricate a jumper wire that can be used to create a short between terminal A (signal) and terminal B (sensor return) at the connector for the exhaust gas temperature sensor. Crimp connector pins to each end of the jumper wire.
- C. Install the jumper onto the harness side of the sensor connector.
- D. Restore the electrical power to the ECM. Wait at least 30 seconds for activation of the diagnostic codes.
- E. Access the “Active Diagnostic Code” screen on the electronic service tool. Check for an active 0535-4 diagnostic code for the exhaust gas temperature sensor.
- F. Remove the electrical power from the ECM.

Expected Result:

A 0535-4 diagnostic code is now active for the exhaust gas temperature sensor.

Results:

- OK – A 0535-3 diagnostic code was active before creating the short at the sensor connector. A 0535-4 diagnostic code became active after creating the short at the sensor connector.

Repair: Temporarily connect a new sensor to the harness, but do not install the new sensor in the engine. Use the electronic service tool in order to verify that the repair eliminates the fault. If there are no active diagnostic codes for the sensor, permanently install the new sensor.

Use the electronic service tool in order to clear all logged diagnostic codes and then verify that the repair eliminates the fault.

STOP.

- Not OK – A 0535-3 diagnostic code is still active for the exhaust gas temperature sensor. Proceed to Test Step 7.

Test Step 7. Check the Operation of the ECM

- A. Remove the electrical power from the ECM.
- B. Check the operation of the ECM by creating an open at the ECM.
 - a. Disconnect the P1 ECM connector.
 - b. Fabricate a jumper wire that is long enough to reach from a terminal at the ECM connector to the engine ground stud. Crimp a connector socket to one end of the jumper wire.
 - c. Remove the signal wire for the suspect sensor from the P1 ECM connector. Install the jumper wire into the terminal location for the signal wire of the suspect sensor.
 - d. Connect the ECM connectors.
 - e. Restore the electrical power to the ECM.
 - f. Monitor the “Active Diagnostic Code” screen on the electronic service tool. Wait at least 30 seconds for activation of the code.

An open circuit diagnostic code 0535-3 will be active for the fuel temperature sensor.

- C. Check the operation of the ECM by creating a short at the ECM.
 - a. Short the jumper wire that is installed into the P1 ECM connector to engine ground.

- b. Monitor the “Active Diagnostic Code” screen on the electronic service tool. Wait at least 30 seconds for activation of the code.

A short circuit diagnostic code 0535-4 will be active for the exhaust gas temperature sensor.

- c. Remove the electrical power from the ECM.
- D. Remove the wire jumper. Reconnect all wires and connectors.

Expected Result:

A 0535-3 diagnostic code is active when the sensor signal wire is open at the ECM connector. A 0535-4 diagnostic code is active when the jumper wire is shorted to engine ground.

Results:

- OK – The ECM is working properly. The fault is in the wiring between the ECM and the sensor connector.

Repair: The fault is most likely in the signal wire for the sensor. Repair the signal wire for the sensor.

If necessary, perform the “Wiggle Test” on the electronic service tool.

Use the electronic service tool in order to clear all logged diagnostic codes and then verify that the repair eliminates the fault.

STOP.

- Not OK – One of the following conditions exists: The 0535-3 diagnostic code is not active when the sensor signal wire is disconnected. The 0535-4 diagnostic code is not active when the wire jumper is installed.

Repair: Connect a test ECM. Refer to Troubleshooting, “Replacing the ECM” and refer to Troubleshooting, “Test ECM Mode”.

If the test ECM eliminates the fault, reconnect the suspect ECM. If the fault returns, permanently install the new ECM.

Use the electronic service tool in order to clear all logged diagnostic codes and then verify that the repair eliminates the fault.

STOP.

i04012478

Fuel Level - Test

System Operation Description:

Use this procedure to troubleshoot any suspect problems with the fuel level sensor.

This procedure covers the following diagnostic codes:

- 96-03 Fuel Pressure Sensor open/short to +batt
- 96-04 Fuel Pressure Sensor short to ground

The fuel level sensor is a passive sensor. The fuel level sensor does not require an operating voltage in order to provide a signal. This configuration utilizes a fuel level buffer that helps to reduce the amount of indicator movement that is passed to the fuel gauge. The buffer is powered through a circuit that is wired directly to a circuit breaker.

When the fuel tank is full, the fuel level sensor has a resistance of 33 Ohms. When the fuel tank is empty, the fuel level sensor has a resistance of 240 Ohms. The resistance from the fuel level sensor varies between these values as the fuel level varies.

An active diagnostic code for the fuel level sensor is probably caused by a problem in the wiring harness. The next likely cause is a problem with the fuel level sensor. The least likely cause is a problem with the Electronic Control Module (ECM).

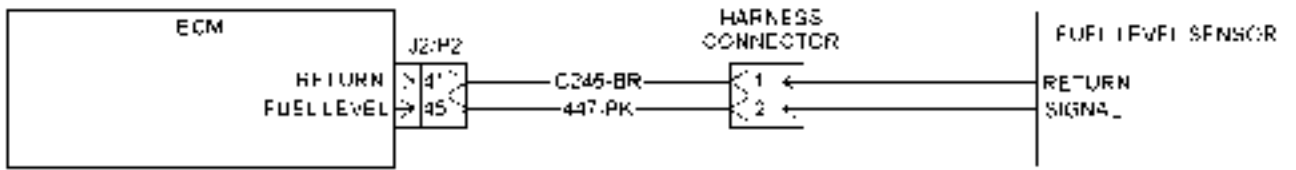

Illustration 65

g02200933

Schematic for the fuel level sensor

Test Step 1. Inspect the Electrical Connectors and the Wiring

- A. Remove the electrical power from the ECM.
- B. Thoroughly inspect the J2/P2 ECM connectors. Refer to the diagnostic functional test Troubleshooting, "Electrical Connectors-Inspect".

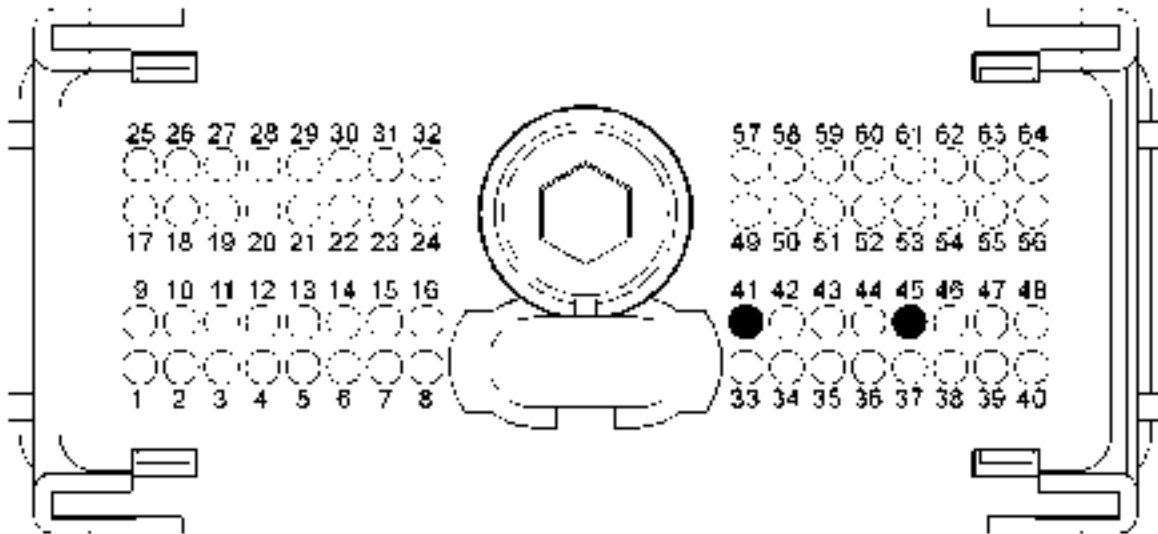

Illustration 66

g02199593

P2 terminals that are associated with the fuel level sensor
 (P2-41) Fuel level sensor signal (P2-45) Sensor return



Illustration 67

g01155187

Fuel level sensor connector

- (1) Fuel level
- (2) Sensor return

- C. Perform a 45 N (10 lb) pull test on each of the wires that are associated with the fuel level sensor.

- D. Check the allen head screw on the ECM connectors for the proper torque. Refer to the diagnostic functional test Troubleshooting, "Electrical Connectors - Inspect".
- E. Check the harness and the wiring for abrasion and for pinch points from the fuel level sensor to the ECM.

Expected Result:

All connectors, pins, and sockets are completely coupled and/or inserted and the harness and wiring are free of corrosion, of abrasion and of pinch points.

Results:

- OK – The connectors and the wiring appear to be OK. Proceed to Test Step 2.
- Not OK – There is a problem in the connectors and/or the wiring.

Repair: Repair the circuit. Verify that the repair eliminates the problem.

STOP.

Test Step 2. Confirm the Fuel Level in the Tank

- A. Visually check the fuel level in the tank.
- B. Compare the fuel level in the tank to the indicator on the fuel level sensor.

Expected Result:

The fuel level in the tank agrees with the indicator on the fuel level sensor.

Results:

- OK – The fuel level in the tank agrees with the indicator on the fuel level sensor. Proceed to Test Step 3.
- Not OK – The indicator on the fuel level sensor does not reflect the actual fuel level in the tank.

Repair: Replace the fuel level sensor. Verify that the repair eliminates the problem.

STOP.

Test Step 3. Check the Status of the Fuel Level

- A. Remove the electrical power from the ECM.
- B. Connect the electronic service tool to the service tool connector.
- C. Restore the electrical power to the ECM.
- D. Observe the status of “Fuel Gauge” on the electronic service tool.

Note: The “Fuel Gauge” on the electronic service tool represents the percentage of fuel level in the tank.

- E. Remove the electrical power from the ECM.

Expected Result:

The status of “Fuel Gauge” displays the correct fuel level.

Results:

- OK – The electronic service tool displays the correct fuel level.

Repair: The fuel level sensor appears to be operating correctly at this time. There may be an intermittent problem in the harness or in a connector. Refer to the diagnostic functional test Troubleshooting, “Electrical Connectors - Inspect”.

STOP.

- Not OK – The electronic service tool does not display the correct fuel level. Proceed to Test Step 4.

Test Step 4. Check the Sensor's Resistance at the Sensor

- A. Disconnect the fuel level sensor connector.

Note: Be sure to wiggle the harness during the following measurement in order to reveal an intermittent condition.

- B. Measure the sensor's resistance between 1 (fuel level) and 2 (sensor return).

The correct resistance is 33 Ohms when the indicator is on “F”. The correct resistance is 240 Ohms when the indicator is on “E”.

Expected Result:

The resistance measurement is between 33 Ohms and 240 Ohms.

Results:

- OK – The resistance of the sensor is between 33 Ohms and 240 Ohms. Record the measurement. Connect the fuel level sensor connector. The sensor's resistance is OK. Proceed to Test Step 5.
- Not OK – The resistance measurement is greater than 240 Ohms or the resistance measurement is less than 33 Ohms.

Repair: Perform the following procedure:

1. Disconnect the fuel level sensor from the vessel's wiring. Verify that the fuel level sensor is operating correctly. Refer to the literature that is provided by the OEM for the sensor.
2. If the sensor is causing the high resistance, adjust the sensor, when possible. Replace the sensor, if necessary.

STOP.

i03460681

Test Step 5. Check the Sensor's Resistance at the ECM**A.** Disconnect the J2/P2 connectors.**Note:** Be sure to wiggle the harness during the following measurement in order to reveal an intermittent condition.**B.** Measure the resistance between P2-41 (fuel level sensor) and P2-45 (sensor return) at the ECM connector.**Expected Result:**

The resistance measurement is approximately equal to the resistance that was measured at the sensor connector.

Results:

- OK – The resistance measurement is approximately equal to the resistance measurement that was recorded in the previous Test Step.

Repair: The fuel level sensor and the wiring are OK. Perform the following procedure:

1. Connect the J2/P2 connectors.
2. Restore the electrical power to the ECM. Check for a diagnostic code for the fuel level sensor again. Wait at least 30 seconds in order for codes to become active.
 - a. If the diagnostic code does not recur, the problem is resolved. The original problem was probably caused by a poor electrical connection. Return the engine to service. STOP.
 - b. If the diagnostic code recurs, Replace the ECM. Refer to electronic troubleshooting Troubleshooting, "Replacing the ECM". Verify that the problem is resolved.

STOP.

- Not OK – The resistance measurement is not approximately equal to the resistance that was measured at the sensor connector. There is a problem with the engine's wiring harness. There may be a problem with a connector.

Repair: Repair the wiring, when possible. Replace parts, if necessary. Verify that the problem is resolved.

STOP.

Fuel Rail Pump Solenoid - Test**System Operation Description:**

Use this procedure to troubleshoot the system when one of the following diagnostic codes is active or easily repeated:

- 1779-05 Fuel Rail #1 Pressure Valve Solenoid current below normal
- 1779-06 Fuel Rail #1 Pressure Valve Solenoid current above normal

Note: The fuel rail pump is installed on the engine at the factory. The fuel rail pump is not serviceable part.

The fuel rail pump solenoid is used to control the output from the fuel rail pump. The solenoid receives an electrical supply from the Electronic Control Module (ECM). The fuel rail pump solenoid is then energized when the fuel is required to be pumped into the fuel rail. Varying the timing of the voltage to the solenoid controls the fuel delivery from the fuel rail pump.

When the fuel rail pump solenoid is deactivated, the fuel that is not sent to the fuel rail is returned to the fuel tank.

The fuel rail pump solenoid forms part of the closed loop control system for the fuel rail pressure in conjunction with the fuel rail pressure sensor, ECM and the software. The fuel rail pressure sensor measures the fuel pressure in the high pressure fuel rail. The signal from the fuel rail pressure sensor is processed by the ECM and software. The measured pressure is compared to the desired fuel rail pressure for the given engine operating conditions.

If the fuel rail pump solenoid fails, it is likely that the fuel will not be pumped into the high pressure fuel rail and engine shutdown or failure to start the engine is expected. Fuel rail pressure can be observed on the status screen of the electronic service tool.

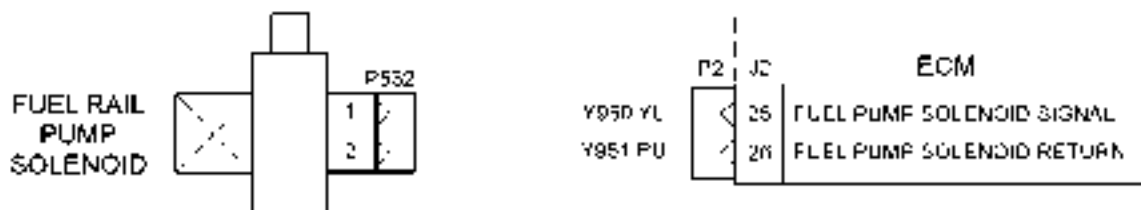

Illustration 68
 Typical schematic of the circuit for the fuel rail pump solenoid

g01803553

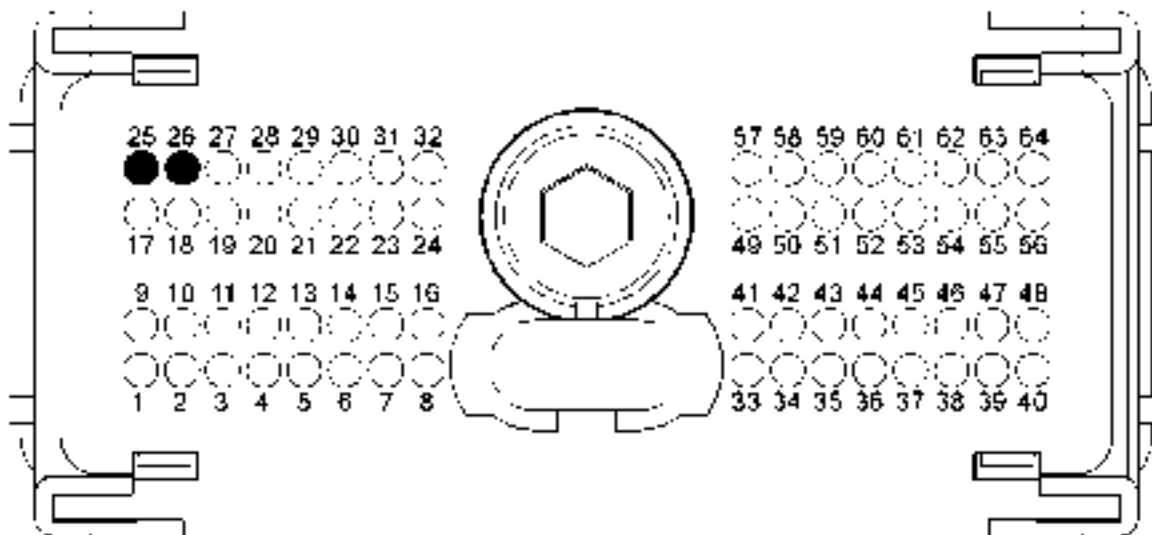

Illustration 69
 Typical view of the P2 pin locations for the electrical power supply circuit
 (25) Fuel rail pump solenoid PWM signal (26) Fuel rail pump solenoid return

g01803554

Test Step 1. Inspect the Electrical Connectors and the Harness

WARNING
 Electrical shock hazard. The fuel rail pump solenoid uses 63 to 73 volts.

- A. Turn the keyswitch to the OFF position.
- B. Thoroughly inspect the harness connector P2/J2 and the suspect connector P532. Refer to Troubleshooting, “Electrical Connectors - Inspect” for details.
- C. Perform a 45 N (10 lb) pull test on each of the wires in the solenoid connector P532 and the connector pins 25 and 26 that are associated with the fuel rail pump solenoid. Refer to illustration 69.
- D. Check the harness for abrasions and for pinch points from the battery to the ECM. Check the harness for abrasions and for pinch points from the key switch to the ECM.
- E. Perform a “Wiggle Test” by using the electronic service tool in order to identify intermittent connections.

Expected Result:

All connectors, pins, and sockets are completely coupled and/or inserted. The harness is free of corrosion, of abrasion, and of pinch points.

Results:

- OK – The connectors and the harness appear to be OK. Proceed to Test Step 2.

- Not OK – There is a fault with the connectors and/or the harness.

Repair: Repair the connectors or the harness and/or replace the connectors or the harness. Ensure that all of the seals are correctly in place and ensure that the connectors are completely coupled.

Use the electronic service tool in order to clear all logged diagnostic codes and then verify that the repair has eliminated the fault.

STOP.

Test Step 2. Check for Active Diagnostic Codes

- Connect the electronic service tool to the diagnostic connector.
- Turn the keyswitch to the ON position.
- Use the electronic service tool to verify if any of the following diagnostic codes are active or recently logged:
 - 1779-05 Fuel Rail #1 Pressure Valve Solenoid current below normal
 - 1779-06 Fuel Rail #1 Pressure Valve Solenoid current above normal

Expected Result:

One or more of the following diagnostic codes are active or recently logged:

- 1779-05 Fuel Rail #1 Pressure Valve Solenoid current below normal
- 1779-06 Fuel Rail #1 Pressure Valve Solenoid current above normal

Results:

- 1779-05 – Proceed to Test Step 3.
- 1779-06 – Proceed to Test Step 7.
- Not OK – No active diagnostic codes or recently logged diagnostic codes are displayed. STOP.

Test Step 3. Check the Harness for an Open Circuit

- Turn the keyswitch to the OFF position.
- Disconnect P2 from the ECM.
- Measure the resistance between P2:25 and P2:26.

Expected Result:

The nominal resistance is less than 2 Ohms.

Results:

- OK – The harness and the solenoid do not have an open circuit.

Repair: Check the high pressure fuel system for leaks. A mechanical relief valve is installed in the high pressure fuel rail. Check that there is no flow of fuel from the mechanical relief valve. Refer to Operation and Maintenance Manual, "High Pressure Fuel Lines".

If the fuel system is Not OK, repair the fuel system and restart the diagnostic process.

If the fuel system is OK, proceed to Test Step 4.

- Not OK – There is an open circuit. Proceed to Test Step 4.

Test Step 4. Check the Fuel Rail Pump Solenoid for an Open Circuit

- Turn the keyswitch to the OFF position.
- Disconnect the connector from the fuel rail pump solenoid.
- Measure the resistance of the fuel rail pump solenoid.

Expected Result:

The nominal resistance is less than 1 Ohm.

Results:

- OK – There is an open circuit or there is an excessive resistance in the harness.

Repair: Repair the connectors or the harness and/or replace the connectors or the harness.

Ensure that all of the seals are correctly in place and ensure that all connectors are correctly coupled.

Use the electronic service tool in order to perform the fuel rail pump solenoid test.

Use the electronic service tool in order to clear all logged diagnostic codes and then verify that the repair eliminated the fault.

STOP.

- Not OK – The fuel rail pump solenoid is faulty.

Repair: Temporarily connect a new fuel rail pump to the harness, but do not install the fuel rail pump to the engine.

Reconnect the P2 to the ECM. Check the screw for the ECM connector for the correct torque of 5.0 N·m (44 lb in).

Use the electronic service tool in order to clear all logged diagnostic codes and then verify that the repair eliminated the fault.

Use the electronic service tool in order to perform the fuel rail pump solenoid test.

If the diagnostic code does not reappear, then install the new fuel rail pump to the engine. Refer to Disassembly and Assembly Manual, "Fuel Injection Pump- Install".

STOP.

Test Step 5. Check the Fuel Rail Pump Solenoid for a Short Circuit

- A. Turn the keyswitch to the OFF position.
- B. Disconnect the connector from the fuel rail pump solenoid.
- C. Turn the keyswitch to the ON position.
- D. Use the electronic service tool in order to perform the solenoid test for the fuel rail pump.

Expected Result:

A "Current Below Normal" diagnostic code is displayed. The "Current Above Normal" diagnostic code is not displayed.

Results:

- OK – A "Current Below Normal" diagnostic code is displayed. The harness has no shorts to supply or ground. The fuel rail pump solenoid is faulty.

Repair: Temporarily connect a new fuel rail pump to the harness, but do not install the fuel rail pump to the engine.

Reconnect P2 to the ECM. Check the screw for the ECM connector for the correct torque of 5.0 N·m (44 lb in).

Use the electronic service tool in order to perform the solenoid test for the fuel rail pump.

Verify that the repair eliminates the fault.

If the diagnostic code has been cleared, then install the new fuel rail pressure pump to the engine. Refer to Disassembly and Assembly, "Electrical Connectors - Inspect".

Use the electronic service tool in order to clear all logged diagnostic codes and then verify that the repair eliminates the fault.

STOP.

- Not OK – The harness is a short circuit or the ECM is a short circuit. Proceed to Test Step 6.

Test Step 6. Check the harness for the Fuel Rail Pump Solenoid for a Short Circuit

- A. Turn the keyswitch to the OFF position.
- B. Disconnect the P532 connector from the fuel rail pump solenoid.
- C. Disconnect the P2 connector from the ECM.
- D. Measure the resistance between P2:26 and P2:25.
- E. Measure the resistance between P2:25 and voltage +.
- F. Measure the resistance between P2:25 and the voltage (-).
- G. Measure the resistance between P2:26 and voltage +.
- H. Measure the resistance between P2:26 and voltage (-).

Expected Result:

The resistance is greater than 20,000 Ohms.

Results:

- OK – The harness has no short circuit to supply or ground. The ECM is suspect. Proceed to Test Step 7.
- Not OK – The harness has a short circuit.

Repair: Repair the harness and connectors or replace the faulty harness and connectors.

Connect the P532 connector to the fuel rail pump solenoid.

Connect the P2 connector to the ECM.

Turn the keyswitch to the ON position.

Use the electronic service tool in order to perform the solenoid test for the fuel rail pump.

Use the electronic service tool in order to clear all logged diagnostic codes and then verify that the repair has eliminated the fault.

STOP.

Test Step 7. Check the ECM and the Harness

- A. Turn the keyswitch to the OFF position.
- B. Disconnect the P532 connector from the fuel rail pump solenoid.
- C. Insert a jumper wire across P532.
- D. Turn the keyswitch to the ON position.
- E. Use the electronic service tool in order to perform the solenoid test for the fuel rail pump.
- F. Use the electronic service tool in order to monitor the status screen.

Expected Result:

A 1779-06 diagnostic code is displayed.

Results:

- OK – The ECM and the ECM connections function. The solenoid is not an open circuit. Recheck the diagnostic codes. Proceed to Test Step 5.
- Not OK – The ECM is suspect. Proceed to Test Step 8.

Test Step 8. Check the ECM Function

A. Make sure that the latest flash file for the application is installed in the ECM. Refer to Troubleshooting, “Flash Programming”.

B. Contact the Technical Help Desk.

Note: This consultation can greatly reduce the repair time.

C. If the Technical Help Desk recommends the use of a test ECM, install a test ECM. Refer to Troubleshooting, “Replacing the ECM”.

D. Replace all connectors.

E. Use the electronic service tool to recheck the system for active diagnostic codes.

F. Use the electronic service tool in order to perform the solenoid test for the fuel rail pump.

Expected Result:

The fault is eliminated.

Results:

- OK

Repair: If the fault is eliminated with the test ECM, perform the following procedure:

1. Reconnect the suspect ECM.
2. If the fault returns with the suspect ECM, replace the ECM.
3. Use the electronic service tool in order to clear all logged diagnostic codes and then verify that the repair eliminates the fault.

STOP.

- Not OK

Repair: Repeat the diagnostic procedure from Step 1.

STOP.

i03460880

Ignition Keyswitch Circuit and Battery Supply Circuit - Test

System Operation Description:

This procedure tests that the correct voltage is being supplied to the Electronic Control Module (ECM).

Use this procedure to troubleshoot the system when one of the following diagnostic codes is active or easily repeated:

- 0168-00 Electrical System Voltage high
- 0168-01 Electrical System Voltage low
- 0168-02 Electrical System Voltage erratic, intermittent, or incorrect
- 1834-02 Ignition Keyswitch loss of signal

The ECM receives electrical power (battery voltage) through the wiring that is supplied by the manufacturer of the application. Unswitched battery voltage is supplied through P1: 7, 8, 15, 16. The negative battery is supplied through P1: 1, 2, 3, 9, 10. The ECM receives the input from the keyswitch at P1:40 when the keyswitch is in the ON position or in the START position. When the ECM detects battery voltage at this input, the ECM will power up. When battery voltage is removed from this input, the ECM will power down.

The cause of an intermittent power supply to the ECM can occur on either the positive side or on the negative side of the battery circuit. The connections for the unswitched battery+ may be routed through a dedicated protection device (circuit breaker).

Some applications may be equipped with an engine protection shutdown system or an idle timer shutdown system that interrupts electrical power to the keyswitch. The engine protection shutdown system can be an aftermarket device and the idle timer shutdown system can be external to the ECM. Some of these systems will not supply power to the ECM until one of the following conditions is met:

- The engine is cranked.
- The engine oil pressure achieves acceptable limits.
- An override button is pressed.

Keep in mind that these devices may be the cause of intermittent power to the ECM. These devices may also shut down the engine.

Usually, battery power to the diagnostic connector is available and the battery power to the data link connector is independent of the keyswitch. Therefore, you will be able to power up the electronic service tool, but you may not be able to communicate with the engine ECM. The engine ECM requires the keyswitch to be in the ON position in order to maintain communications. The ECM may power down a short time after connecting the electronic service tool if the keyswitch is in the OFF position. This is normal.

For intermittent faults such as intermittent shutdowns that could be caused by the application wiring, temporarily bypassing the application wiring may be an effective means of determining the root cause. If the symptoms disappear with the bypass wiring, the application wiring is the cause of the fault. A means of bypassing the application wiring is explained in this test procedure. This is especially important for applications that do not provide dedicated circuits for the unswitched battery and the connections for the keyswitch.

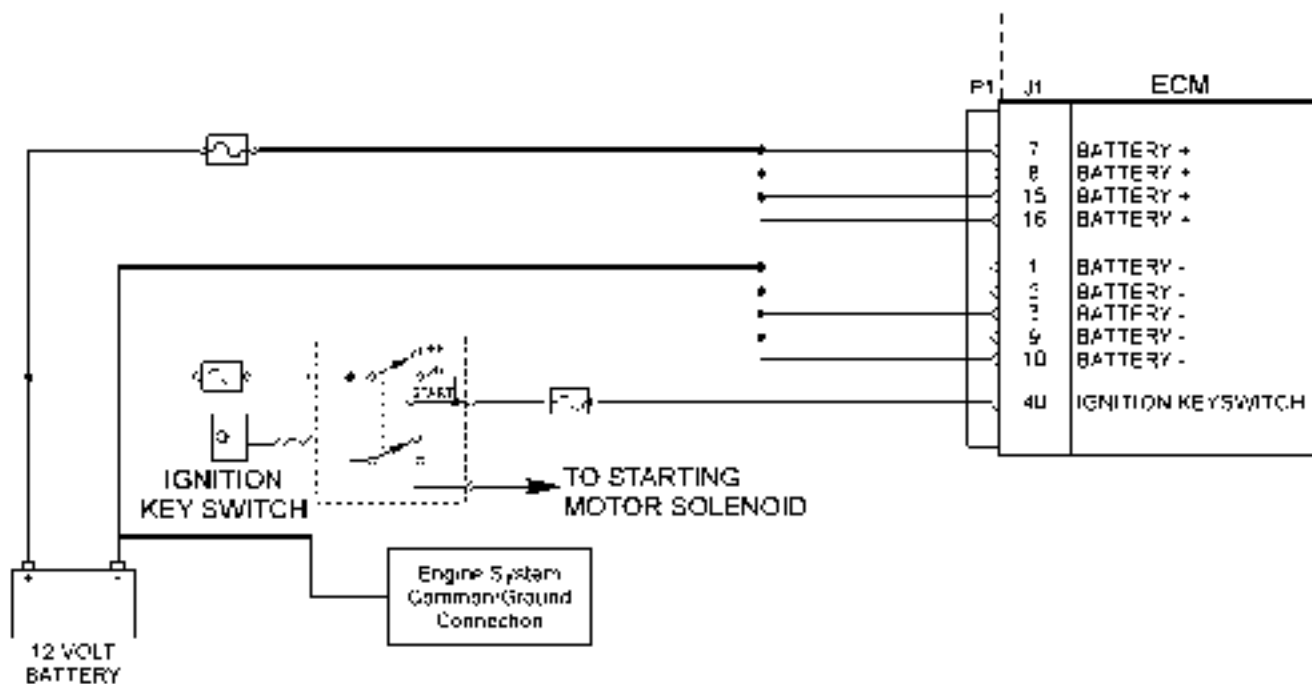

Illustration 70

g01803755

Schematic for the ignition keyswitch and battery supply circuit

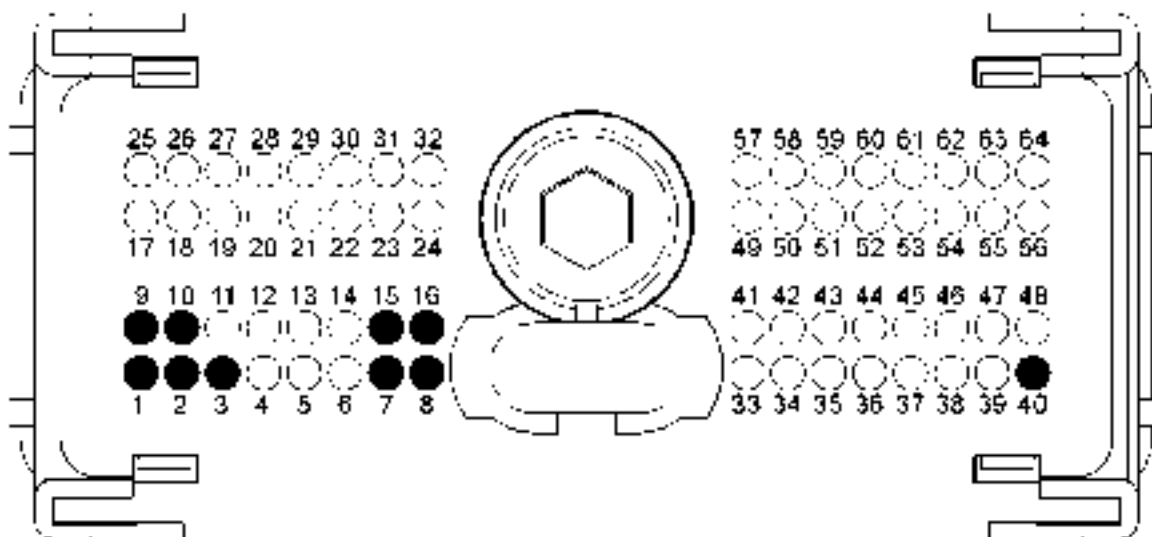

Illustration 71

g01803934

Typical view of the pin locations on the P1 connector for the ignition keyswitch and battery supply circuit

- | | | |
|--------------------------|---------------------------|--------------------------|
| (1) Battery ground (GND) | (8) Battery (+) | (16) Battery ground (+) |
| (2) Battery ground (GND) | (9) Battery ground (GND) | (40) Ignition key switch |
| (3) Battery ground (GND) | (10) Battery ground (GND) | |
| (7) Battery (+) | (15) Battery ground (+) | |

Test Step 1. Inspect Electrical Connectors and Wiring

- A.** Thoroughly inspect the P1 connector, the battery connections and the connections to the keyswitch. Refer to Troubleshooting, “Electrical Connectors - Inspect” for details.
- B.** Perform a 45 N (10 lb) pull test on each of the wires in the ECM connector that are associated with the following connections:
- P1: 7, 8, 15, 16 (Unswitched Battery+)
 - P1: 1, 2, 3, 9, 10 (Battery-)
 - P1:40 (keyswitch)
- C.** Use the electronic service tool to perform a “Wiggle Test”. Special attention must be paid to the following connections:
- P1: 7, 8, 15, 16
 - P1: 1, 2, 3, 9, 10
 - P1:40
- D.** Check the ECM connector for the correct torque of 5.0 N·m (44 lb in).
- E.** Check the harness for abrasion and for pinch points from the battery to the ECM, and from the keyswitch to the ECM.

Expected Result:

All connectors, pins and sockets are completely coupled and/or inserted and the harness is free of corrosion, of abrasion or of pinch points.

Results:

- OK – The harness and connectors appear to be OK. Proceed to Test Step 2.
- Not OK – There is a fault with the connectors and/or the harness.

Repair: Repair the connectors or the harness or replace the connectors or the harness. Ensure that all of the seals are correctly installed and ensure that the connectors are completely coupled.

Use the electronic service tool in order to clear all logged diagnostic codes and then verify that the repair eliminates the fault.

STOP.

Test Step 2. Check for Active Diagnostic Codes or Logged Diagnostic Codes

- A.** Connect the electronic service tool to the diagnostic connector.
- B.** Turn the keyswitch to the ON position.
- C.** Monitor the active diagnostic code screen on the electronic service tool. Check and record any active diagnostic codes or logged diagnostic codes.

Note: Wait at least 30 seconds in order for the diagnostic codes to become active.

Expected Result:

One of the following diagnostic codes is active or logged:

- 168-0 Electrical System Voltage high
- 168-1 Electrical System Voltage low
- 168-2 Electrical System Voltage erratic, intermittent, or incorrect
- 1834-2 Ignition Keyswitch loss of signal

Note: Diagnostic code 1834-2 can be generated by rapidly cycling the keyswitch. If diagnostic code 1834-2 is logged but not active, this may be the cause.

Results:

- OK – A 168 or a 1834-02 diagnostic code is active or logged. Proceed to Test Step 3.
- Not OK – No diagnostic code is active.

Repair: The fault is no longer present. If the fault is intermittent, refer to Troubleshooting, “Electrical Connectors - Inspect”.

STOP.

Test Step 3. Check the Battery Voltage at the ECM Connector

- A.** Disconnect the connector P1 from the ECM connector.
- B.** Turn the keyswitch to the ON position.
- C.** Measure the voltage between P1:7 (Unswitched Battery+) and P1:1 (Battery-).
- D.** Measure the voltage between P1:8 (Unswitched Battery+) and P1:2 (Battery-).

- E. Measure the voltage between P1:15 (Unswitched Battery+) and P1:9 (Battery-).
- F. Measure the voltage between P1:16 (Unswitched Battery+) and P1:10 (Battery-).
- G. Measure the voltage between P1:40 (keyswitch) and P1:3 (Battery-).
- H. Turn the keyswitch to the OFF position.

Expected Result:

For 12 Volt systems, the measured voltage is a constant 11.0 to 13.5 Volts DC with no suspected intermittent faults at this time.

For 24 Volt systems, the measured voltage is a constant 22.0 to 27.0 Volts DC with no suspected intermittent faults at this time.

Results:

- OK – The ECM is receiving the correct voltage.

Repair: If an intermittent condition is suspected, refer to Troubleshooting, “Electrical Connectors - Inspect”.

STOP.

- Not OK – The ECM is not receiving the correct voltage.

Repair: Check for continuity in the harness for the keyswitch from P1:40 through the keyswitch circuit to the batteries. Check the circuit protection for the circuit. Refer to the service manual for the instructions on troubleshooting the circuit for the keyswitch.

For intermittent problems such as intermittent shutdowns that could be caused by the application wiring, temporarily bypassing the application wiring may be an effective means of determining the root cause.

Proceed to Test Step 5.

- Not OK – No voltage is present on P1: 7, 8, 15, 16.

Repair: Check for continuity in the harness for the unswitched Battery+ from the ECM to the batteries. Check the circuit protection for the circuit. Check for continuity in the harness for the Battery- from the ECM to the batteries.

For intermittent faults such as intermittent shutdowns that could be caused by the application wiring, temporarily bypassing the application wiring may be an effective means of determining the root cause.

Proceed to Test Step 5.

- Not OK – The battery voltage is out of limits. Proceed to Test Step 4.

Test Step 4. Check the Batteries

A. Measure the no-load battery voltage at the battery terminals.

B. Load test the batteries. Use a suitable battery load tester.

Expected Result:

The batteries pass the load test. For 12 Volt systems, the measured voltage is at least 11.0 Volts DC. For 24 Volt systems, the measured voltage is at least 22.0 Volts DC.

Results:

- OK – The batteries pass the load test. For 12 Volt systems, the measured voltage is at least 11.0 Volts DC. For 24 Volt systems, the measured voltage is at least 22.0 Volts DC.

Repair: Refer to the service manual for the application for instructions on troubleshooting the application harness. Troubleshoot the application harness and repair the application harness, as required.

Use the electronic service tool in order to clear all logged diagnostic codes and then verify that the repairs eliminate the fault.

STOP.

- Not OK – The batteries do not pass the load test. For 12 Volt systems, the measured voltage is less than 11.0 Volts DC. For 24 Volt systems, the measured voltage is less than 22.0 Volts DC.

Repair: Recharge or replace the faulty batteries.

Use the electronic service tool in order to clear all logged diagnostic codes and then verify that the repair eliminates the fault.

STOP.

Test Step 5. Bypass the Application Harness

WARNING

Batteries give off flammable fumes which can explode.

To avoid injury or death, do not strike a match, cause a spark, or smoke in the vicinity of a battery.

NOTICE

Do not connect the bypass harness to the battery until all of the in-line fuses have been removed from the Battery+ line. If the fuses are not removed before connection to the battery, a spark may result.

Note: The bypass harness is only for test applications. This bypass harness must be removed before the application is released to the customer. The bypass harness can be used in order to determine if the cause of the intermittent fault is an interruption in battery power to the ECM or to the keyswitch circuit.

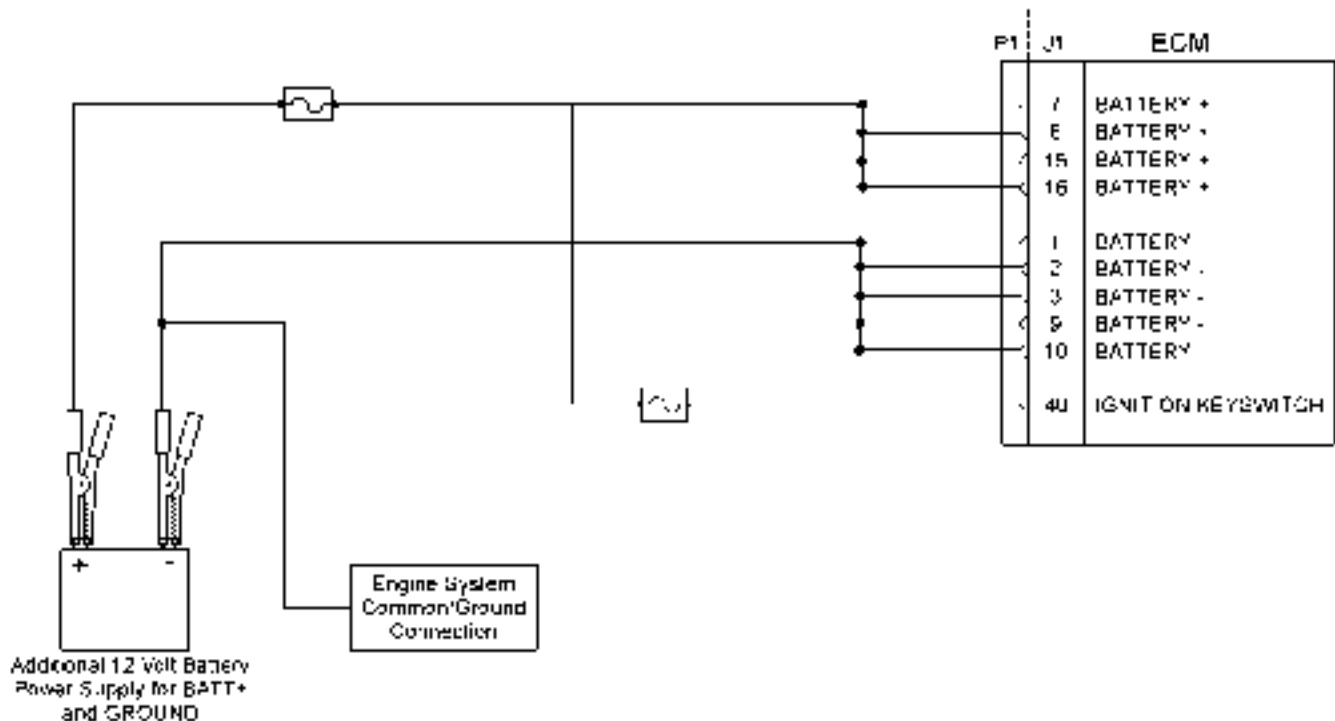

Illustration 72

g01803954

Schematic for the bypass application harness

- Turn the keyswitch to the OFF position.
- Disconnect the P1 connector from the ECM connector.
- Connect a bypass harness to the ECM.
- Remove the fuses from the Battery+ wire of the bypass harness and connect the Battery+ and the Battery- wires directly to the battery terminals.

Note: This bypass directly connects the circuit for the keyswitch to the ECM. The ECM will remain powered until the connection to the unswitched battery+ line is disconnected. Remove the fuses from the in-line fuse holder to power down the ECM. Do not connect the bypass to the battery terminals or do not remove the bypass from the battery terminals without first removing the in-line fuses.

E. Connect the electronic service tool to the diagnostic connector of the bypass harness and verify that communication can be established.

Note: Remove the bypass harness and restore all wiring to the original condition after testing.

Expected Result:

Installing the bypass eliminates the fault.

Note: The status of the "Ignition Keyswitch" will always indicate ON while the bypass harness is installed.

Results:

- OK – The symptom disappears when the bypass harness is installed. The symptom returns when the bypass harness is removed. The fault is in the wiring for the application that supplies power to the ECM. Check for aftermarket engine protection switches that interrupt power. Send the application to the OEM dealer to repair. STOP.
- Not OK – The symptom is still present when the bypass harness is installed.

Repair: Connect the bypass to another battery and verify if the fault is resolved. If the fault is resolved, the fault is with the batteries on the application.

If the fault still exists, perform the following procedure:

1. Make sure that the latest flash file for the application is installed in the ECM. Refer to Troubleshooting, "Flash Programming".
2. Contact the Technical Help Desk.

Note: This consultation can greatly reduce the repair time.

3. If the Technical Help Desk recommends the use of a test ECM, install a test ECM. Refer to Troubleshooting, "Replacing the ECM".
4. Use the electronic service tool to recheck the system for active diagnostic codes.
5. If the fault is resolved with the test ECM, reconnect the suspect ECM.

6. If the fault returns with the suspect ECM, replace the ECM.

7. Use the electronic service tool in order to clear all logged diagnostic codes and then verify that the repair eliminates the fault.

STOP.

i04011070

Indicator Lamp Circuit - Test

System Operation Description:

Use this procedure under the following circumstances:

- The lamps are not receiving battery voltage.
- The lamps are not operating correctly.

Also, use this procedure if another procedure has directed you here.

The following diagnostic lamps are available:

- Warning lamp
- Diagnostic lamp
- High coolant temperature lamp
- Low coolant level lamp
- Low oil pressure lamp
- Maintenance lamp
- Water in fuel lamp

The electronic service tool can be used as a diagnostic aid in order to switch the individual lamps ON and OFF.

Note: The diagnostic function that switches the lamps is contained in the "Override" section in the "Diagnostics" menu of the electronic service tool.

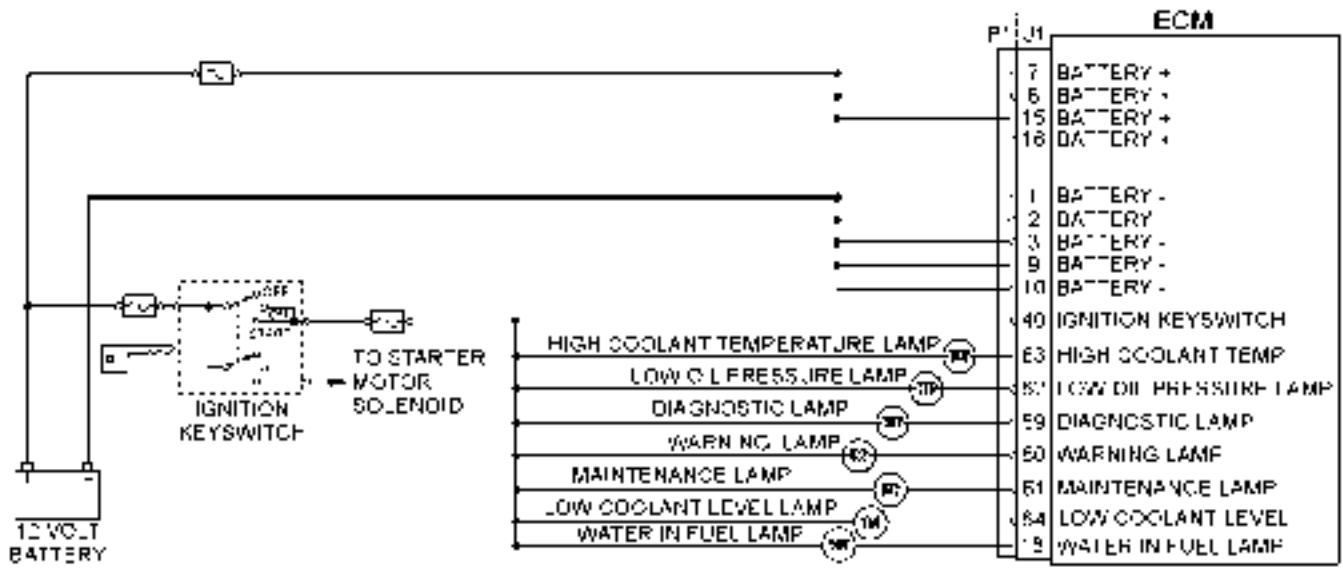

Illustration 73

g02186513

Typical schematic of the indicator lamp circuit

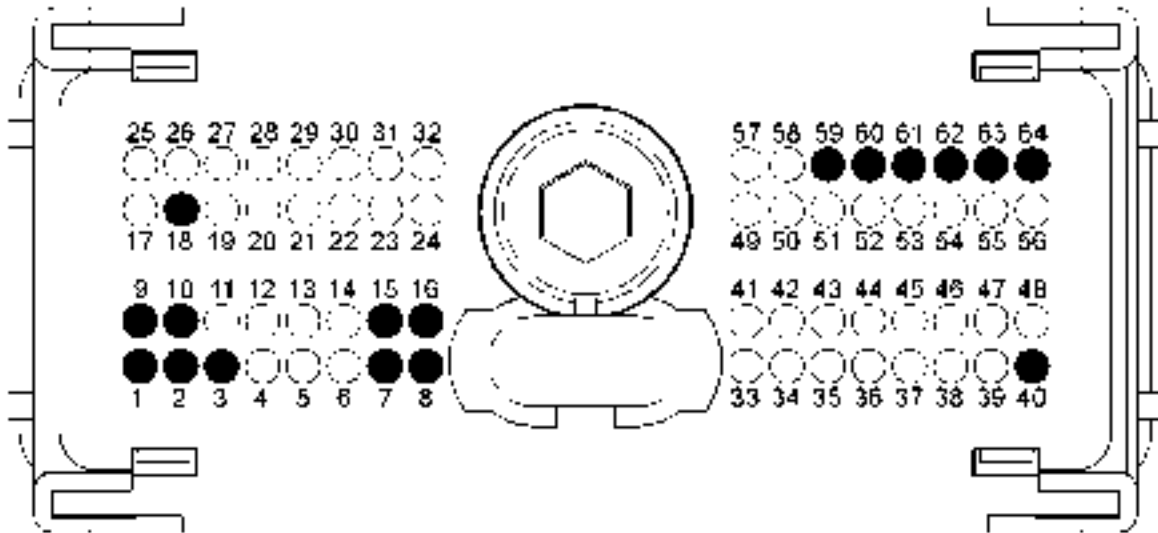

Illustration 74

g02186514

Typical example of the pin locations on the P1 connector

- | | | |
|--------------|-------------------------|------------------------------------|
| (1) Ground | (8) Battery+ | (60) Warning lamp |
| (2) Ground | (15) Battery+ | (61) Maintenance lamp |
| (3) Ground | (16) Battery+ | (62) Low oil pressure lamp |
| (9) Ground | (18) Water in fuel lamp | (63) High coolant temperature lamp |
| (10) Ground | (40) Keyswitch | (64) Low coolant level lamp |
| (7) Battery+ | (59) Diagnostic lamp | |

Test Step 1. Inspect Electrical Connectors and Wiring

- A. Turn the keyswitch to the OFF position.
- B. Thoroughly inspect P1 connector and the lamp connections. Refer to Troubleshooting, "Electrical Connectors - Inspect" for details.
- C. Perform a 45 N (10 lb) pull test on each of the wires in the customer connector and the Electronic Control Module (ECM) connector that is associated with the diagnostic lamp.
- D. Check the screw for the P1 connector for the correct torque of 5.0 N·m (44 lb in).
- E. Check the harness for abrasions and for pinch points from the battery to the ECM.

Results:

- OK – Proceed to Test Step 2.
- Not OK

Repair: Repair the connectors or the harness or replace the connectors or the harness. Ensure that all of the seals are correctly installed and ensure that the connectors are completely coupled.

Use the electronic service tool in order to clear all logged diagnostic codes and then verify that the repair eliminates the fault.

STOP.

Test Step 2. Inspect the Lamp, the Fuse, and the Power Supply

- Disconnect the lamp from the harness. Inspect the lamp in order to determine if the lamp has failed.
- Measure the resistance across the two terminals of the lamp. If the resistance is more than 2000 Ohms, the bulb has failed.
- Check the battery by connecting a test lamp across the terminal of the battery.

Expected Result:

The lamp has less than 2000 Ohms and the power supply is OK.

Results:

- OK – The lamp appears to be operating correctly at this time. Proceed to Test Step 3.
- Not OK

Repair: Replace the suspect component or repair the suspect component.

Use the electronic service tool in order to clear all logged diagnostic codes and then verify that the repairs have eliminated the fault.

STOP.

Test Step 3. Measure the Input to the Lamp at the Lamp Socket

- Turn the keyswitch to the ON position.
- Use the electronic service tool to select the “Override” function in order to switch individual lamps ON and OFF.

Note: The “Override” function is contained in the “Diagnostics” menu of the electronic service tool.

- Measure the voltage at the lamp socket.

Expected Result:

The voltage should be between 12.0 Volts DC and 24.0 Volts DC.

Results:

- OK – The voltage is between 12.0 Volts DC and 24.0 Volts DC.

Repair: Replace the bulb.

Verify that the repair eliminates the fault.

If the fault persists, measure the resistance across the 2 terminals of the lamp. If the resistance is more than 2000 Ohms, the replacement bulb has failed. Replace the bulb and repeat the test.

If the fault persists, proceed to Test Step 4.

- Not OK – The voltage is not in the range that is expected. Proceed to Test Step 5.

Test Step 4. Test the Individual Lamp Circuits

- Disconnect the P1 connector.
- Temporarily disconnect the wire from the P1 connector socket that supplies the suspect lamp.
- By using a jumper wire, connect the removed wire to the battery-.
- Turn the keyswitch to the ON position and observe the lamp.

Expected Result:

The diagnostic lamp turns ON while the jumper is connected. Also, the diagnostic lamp turns OFF when the jumper is removed.

Results:

- OK – The circuit for the diagnostic lamp is functioning correctly. Proceed to Test Step 5.
- Not OK – The lamp did not turn ON. The lamp circuit is not functioning correctly. There is a fault in the harness between the lamp and the ECM.

Repair: Repair the lamp circuit.

Use the electronic service tool in order to clear all logged diagnostic codes and then verify that the repair eliminated the fault.

STOP.

Test Step 5. Check the Voltage at the ECM

i04012451

- A. Disconnect the P1 connector.
- B. Temporarily disconnect the wire from the P1 connector that supplies the suspect lamp.
- C. Fabricate the jumper wire with a suitable pin for the P1 connector.
- D. Install one end of the jumper wire into the P1 connector that supplies the suspect lamp. Connect a test lamp between the battery+ and the jumper wire.
- E. Reinstall the P1 connector to the ECM.
- F. Turn the keyswitch to the ON position. Use the electronic service tool to select the override function in order to switch individual lamps ON and OFF.

Note: The “Override” function is contained in the “Diagnostics” menu of the electronic service tool.

Expected Result:

The lamp should illuminate.

Results:

- OK – The ECM is operating correctly. There is a fault in the wiring or the lamp. Repair the wiring or the lamp, as required. Verify that the repair eliminates the fault.

STOP.

- Not OK – There is a suspected fault in the ECM.

Repair: Perform the following procedure:

1. Make sure that the latest flash file for the application is installed in the ECM. Refer to Troubleshooting, “Flash Programming”.
2. Contact the Technical Help Desk.

Note: This consultation can greatly reduce the repair time.

3. If the Technical Help Desk recommends the use of a test ECM, install a test ECM. Refer to Troubleshooting, “Replacing the ECM”.
4. If the fault is resolved with the test ECM, reconnect the suspect ECM.
5. If the fault returns with the suspect ECM, replace the ECM.

STOP.

Injector Data Incorrect - Test

System Operation Description:

Use this procedure under the following situation:

Use this procedure for any of the following diagnostic codes:

- 0001-02 Cylinder #1 Injector erratic, intermittent, or incorrect
- 0002-02 Cylinder #2 Injector erratic, intermittent, or incorrect
- 0003-02 Cylinder #3 Injector erratic, intermittent, or incorrect
- 0004-02 Cylinder #4 Injector erratic, intermittent, or incorrect
- 0005-02 Cylinder #5 Injector erratic, intermittent, or incorrect
- 0006-02 Cylinder #6 Injector erratic, intermittent, or incorrect

The following background information is related to this procedure:

The engine has electronic unit injectors that are electronically controlled by the Electronic Control Module (ECM). The ECM sends a 70 V pulse to each injector solenoid. The pulse is sent at the correct time and for the correct duration for a given engine load and engine speed. Use this procedure to identify the cause of the diagnostic code. Use this procedure to repair the system.

If an injector is replaced, then the correct injector trim files must be programmed into the ECM. The injector trim files allow each individual injector to be fine-tuned for optimum performance. The ECM will generate the following diagnostic code if the injector trim files are not programmed:

- 0268-02 Programmed Parameter Fault erratic, intermittent, or incorrect

Refer to Troubleshooting, “Injector Trim File” for further information.

If the ECM is replaced then the replacement ECM must be correctly programmed. Refer to Troubleshooting, “Replacing the ECM” for further information.

Use the electronic service tool in order to perform the "Fuel System Verification Test". The "Fuel System Verification Test" is used to check that the system operates correctly after a repair has been made.

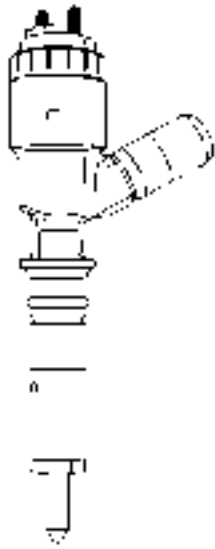

Illustration 75

g01336666

Typical example of the electronic unit injector

Test Step 1. Check for Diagnostic Codes That Are Related to this Procedure

- A. Connect the electronic service tool to the diagnostic connector.
- B. Turn the keyswitch to the ON position.
- C. Check for logged diagnostic codes that are related to this procedure.
- D. Make a note of the logged diagnostic codes.

Expected Result:

Expected Result 1

One or more of the following diagnostic codes are logged:

- 1-2 Cylinder #1 Injector erratic, intermittent, or incorrect
- 2-2 Cylinder #2 Injector erratic, intermittent, or incorrect
- 3-2 Cylinder #3 Injector erratic, intermittent, or incorrect
- 4-2 Cylinder #4 Injector erratic, intermittent, or incorrect
- 5-2 Cylinder #5 Injector erratic, intermittent, or incorrect

- 6-2 Cylinder #6 Injector erratic, intermittent, or incorrect

Expected Result 2

On six cylinder engines, three injectors that share a common supply indicate a diagnostic code.

Note: Injectors 1, 2 and 3 share a common injector driver circuit in the ECM. Injectors 4, 5 and 6 share a common driver circuit in the ECM. If three injectors that share a common supply indicate a diagnostic code then this is probably caused by a faulty ECM.

Results:

- OK – Result 1 One or more diagnostic codes are logged. Proceed to Test Step 2.
- OK – Result 2 On six cylinder engines, three injectors that share a common supply indicate a diagnostic code. Proceed to Test Step 3.
- Not OK – No related diagnostic codes are logged. STOP.

Test Step 2. Check the Faulty Cylinder Numbers

- A. Use the electronic service tool in order to make a note of the logged diagnostic codes.
- B. Use the noted diagnostic codes in order to check the cylinders for faulty injectors.

Expected Result:

The diagnostic codes indicate the cylinder numbers that have faulty injectors.

Results:

- OK – No related diagnostic codes are logged. STOP.
- Not OK – The diagnostic codes indicate the cylinder numbers that have faulty injectors.

Repair: Replace the faulty injectors.

Use the electronic service tool in order to program the replacement injector trim files. Refer to Troubleshooting, "Injector Trim File" for further information.

Use the electronic service tool in order to clear the logged codes.

Turn the keyswitch to the ON position.

Start the engine.

Use the electronic service tool in order to perform the "Fuel System Verification Test". If the cylinders indicate "PASS", then the fault has been cleared.

Use the electronic service tool in order to clear all logged diagnostic codes and then verify that the repair eliminates the fault.

STOP.

Test Step 3. Check the ECM

A. Make sure that the latest flash file for the application is installed in the ECM. Refer to Troubleshooting, "Flash Programming".

B. Contact the Technical Help Desk.

Note: This consultation can greatly reduce the repair time.

C. If the Technical Help Desk recommends the use of a test ECM, install a test ECM. Refer to Troubleshooting, "Replacing the ECM".

D. Use the electronic service tool in order to perform the "Fuel System Verification Test". Verify that the test eliminates the fault.

Note: The "Fuel System Verification Test" will indicate if the cylinder has a "Pass" or "Fail". If the cylinders indicate "Pass" then the fault has been cleared.

E. If the fault is resolved with the test ECM, reconnect the suspect ECM.

F. Use the electronic service tool in order to perform the "Fuel System Verification Test".

Expected Result:

The test ECM clears the fault. Using the electronic service tool in order to perform the "Fuel System Verification Test" with the suspect ECM indicates a "FAIL" condition.

Results:

- OK

Repair: The test ECM eliminates the fault and the suspect ECM indicates a "FAIL" condition. Perform the following procedure:

1. Replace the faulty ECM.
2. Use the electronic service tool in order to clear all logged diagnostic codes and then verify that the repair eliminates the fault.

STOP.

- Not OK – The test ECM did not eliminate the fault. Carefully repeat this procedure from Test Step 1.

i04011072

Injector Solenoid Circuit - Test

System Operation Description:

Use this procedure to troubleshoot any suspected faults with the injector solenoids.

Use this procedure for the following diagnostic codes:

- 0001-05 Cylinder #1 Injector current below normal
- 0001-06 Cylinder #1 Injector current above normal
- 0002-05 Cylinder #2 Injector current below normal
- 0002-06 Cylinder #2 Injector current above normal
- 0003-05 Cylinder #3 Injector current below normal
- 0003-06 Cylinder #3 Injector current above normal
- 0004-05 Cylinder #4 Injector current below normal
- 0004-06 Cylinder #4 Injector current above normal
- 0005-05 Cylinder #5 Injector current below normal
- 0005-06 Cylinder #5 Injector current above normal
- 0006-05 Cylinder #6 Injector current below normal
- 0006-06 Cylinder #6 Injector current above normal

Perform this procedure under conditions that are identical to the conditions that exist when the fault occurs. Typically, faults with the injector solenoid occur when the engine is warmed up and/or when the engine is under vibration (heavy loads).

The engine has Electronic Unit Injectors (EUI) that are mechanically actuated and electronically controlled. The Electronic Control Module (ECM) sends a pulse to each injector solenoid. The pulse is sent at the correct time and for the correct duration for a given engine load and speed. The solenoid is mounted on top of the fuel injector body.

If an open circuit is detected in the solenoid, a diagnostic code is generated. The ECM continues to try to fire the injector. If a short circuit is detected, a diagnostic code is generated. The ECM will disable the solenoid circuit. The ECM will periodically try to fire the injector. If the short circuit remains, this sequence of events will be repeated until the fault is corrected.

“Injector Solenoid Test”

Use the “Injector Solenoid Test” on the electronic service tool to aid in diagnosing an open circuit or a short circuit diagnostic code while the engine is not running. The “Injector Solenoid Test” will send a signal to each solenoid. The electronic service tool will indicate the status of the solenoid as “OK”, “Open”, or “Short”.

Note: On six cylinder engines, the use of a shared supply will mean that a short circuit in the wire that is used as a supply for the injector solenoid will cause three cylinders to have diagnostic codes.



Illustration 76

g01336666

Typical example of the fuel injector

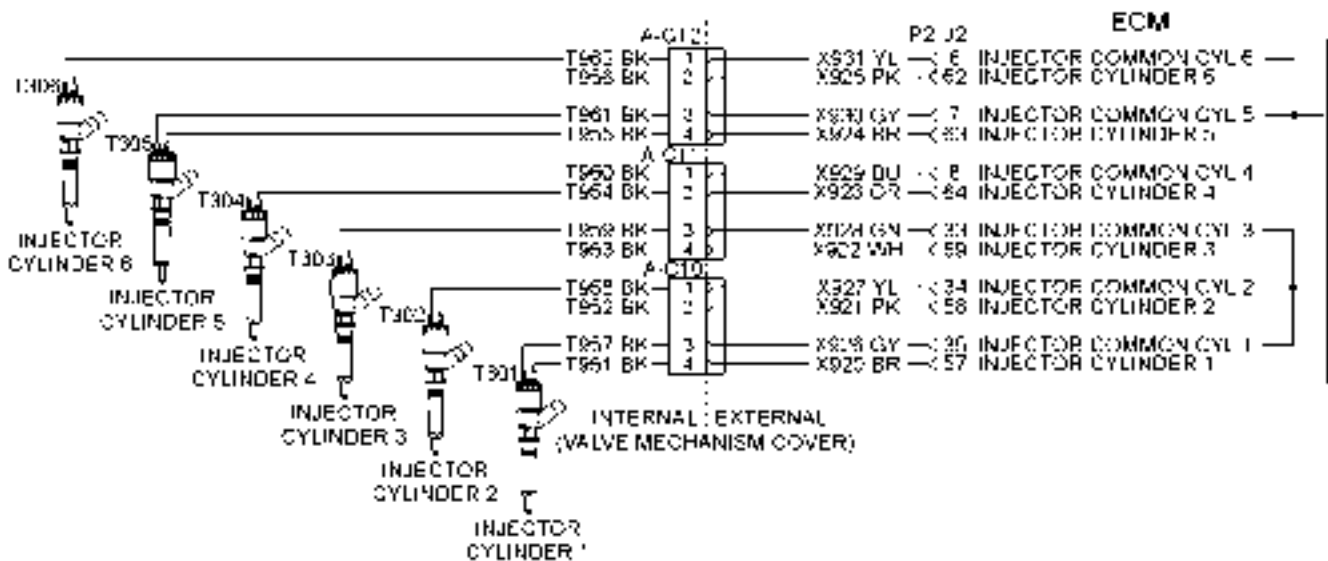

Illustration 77

g02249213

Schematic for the injector solenoid circuit for the engine

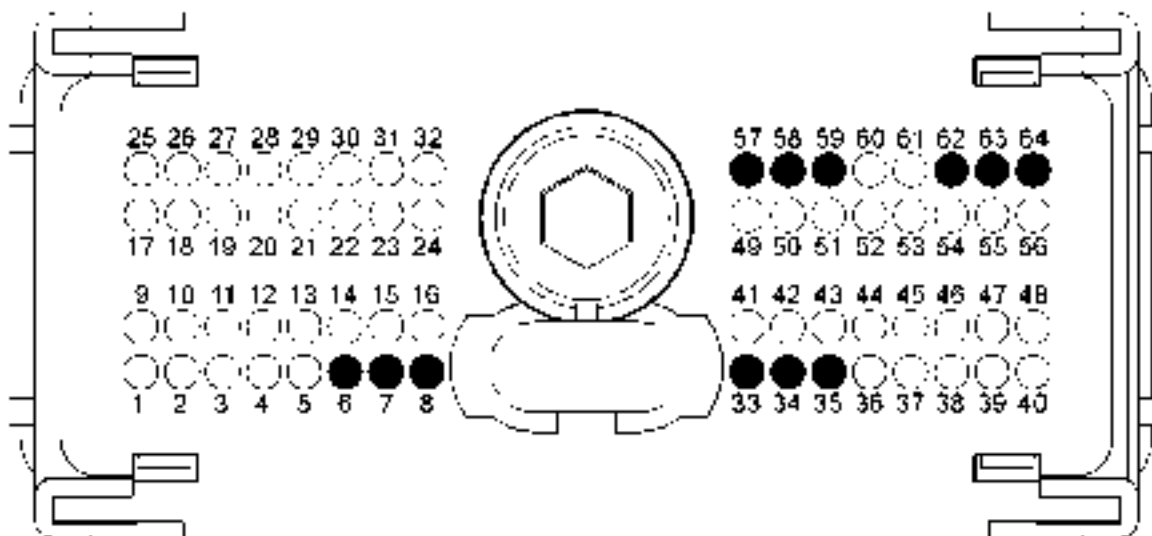

Illustration 78

g01805334

P2 pin connections for the engine

- | | | |
|--|--|---|
| (57) Injector Cylinder (Number 1) | (59) Injector Cylinder (Number 3) | (63) Injector Cylinder (Number 5) |
| (35) Injector Cylinder (Number 1 Return) | (33) Injector Cylinder (Number 3 Return) | (7) Injector Cylinder (Number 5 Return) |
| (58) Injector Cylinder (Number 2) | (64) Injector Cylinder (Number 4) | (62) Injector Cylinder (Number 6) |
| (34) Injector Cylinder (Number 2 Return) | (8) Injector Cylinder (Number 4 Return) | (6) Injector Cylinder (Number 6 Return) |

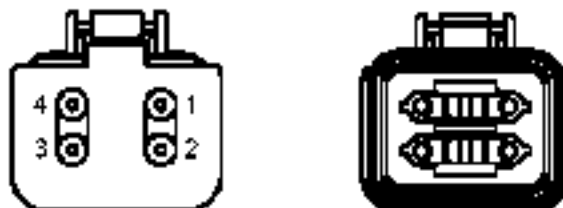

Illustration 79

g01245543

Typical example of the fuel injector harness connector

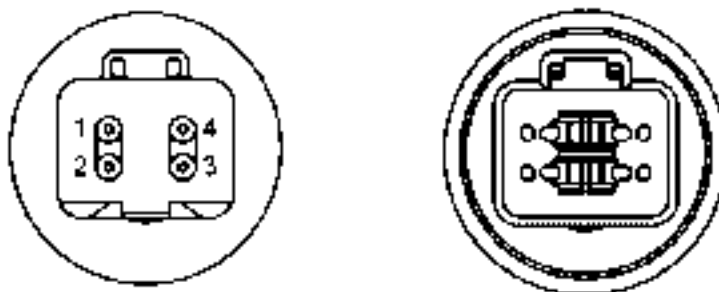

Illustration 80

g01245544

Typical example of the connector on the valve mechanism cover

Test Step 1. Inspect Electrical Connectors and Wiring



Electrical shock hazard. The electronic unit injector system uses 67-73 volts.

- A. Turn the keyswitch to the OFF position. A strong electrical shock hazard is present if the keyswitch is not turned OFF.
- B. Thoroughly inspect connector P2. Thoroughly inspect the connectors at the valve cover base. Refer to Troubleshooting, “Electrical Connectors - Inspect” for details.
- C. Perform a 45 N (10 lb) pull test on each of the wires in the ECM connector that are associated with injector solenoids.
- D. Check the screw for the ECM connector for the correct torque of 5.0 N·m (44 lb in).
- E. Check the harness and wiring for abrasion and for pinch points from the injectors to the ECM.

Expected Result:

All connectors, pins, and sockets are completely coupled and/or inserted and the harness is free of corrosion, of abrasion and of pinch points.

Results:

- OK – The harness is OK. Proceed to Test Step 2.
- Not OK – There is a fault in the connectors and/or the harness.

Repair: Repair the connectors or the harness or replace the connectors or the harness. Ensure that all of the seals are correctly installed and ensure that the connectors are completely coupled.

Use the electronic service tool in order to clear all logged diagnostic codes and then verify that the repair eliminates the fault.

STOP.

Test Step 2. Check for Logged Diagnostic Codes that are Related to the Injector Solenoids

- A. Connect the electronic service tool to the diagnostic connector.
- B. Turn the keyswitch to the ON position.

- C. Check for logged diagnostic codes that are related to the injector solenoids on the electronic service tool.

Expected Result:

One or more diagnostic codes that are related to the injector solenoids have been logged:

- 1-5 Cylinder #1 Injector current below normal
- 1-6 Cylinder #1 Injector current above normal
- 2-5 Cylinder #2 Injector current below normal
- 2-6 Cylinder #2 Injector current above normal
- 3-5 Cylinder #3 Injector current below normal
- 3-6 Cylinder #3 Injector current above normal
- 4-5 Cylinder #4 Injector current below normal
- 4-6 Cylinder #4 Injector current above normal
- 5-5 Cylinder #5 Injector current below normal
- 5-6 Cylinder #5 Injector current above normal
- 6-5 Cylinder #6 Injector current below normal
- 6-6 Cylinder #6 Injector current above normal

Results:

- OK – One or more diagnostic codes have been logged. Proceed to Test Step 3.
- Not OK – No diagnostic codes have been logged. Proceed to Test Step 4.

Test Step 3. Use the “Injector Solenoid Test”

- A. Start the engine.
- B. Allow the engine to warm up to the normal operating temperature.
- C. Stop the engine.
- D. Turn the keyswitch to the ON position.
- E. Access the “Injector Solenoid Test” by accessing the following display screens in order:
 - “Diagnostics”
 - “Diagnostic Tests”
 - “Injector Solenoid Test”
- F. Activate the test.

Note: Do not confuse the “Injector Solenoid Test” with the “Cylinder Cutout Test”. The “Cylinder Cutout Test” is used to shut off fuel to a specific cylinder while the engine is running. The “Injector Solenoid Test” is used to actuate the injector solenoids while the engine is not running. This allows the click of the injector solenoids to be heard while the engine is off in order to determine that the circuit is functioning correctly.

G. As each solenoid is energized by the ECM, an audible click can be heard at the valve cover.

Expected Result:

All cylinders indicate “OK”.

Results:

- OK – There is not an electronic fault with the injectors at this time.

Repair: If the “Injector Solenoid Test” returned a “Not OK” for any injector, refer to Troubleshooting, “Engine Misfires, Runs Rough or Is Unstable”.

STOP.

- Open – Note the cylinders that indicate “Open”. Proceed to Test Step 5.
- Short – Note the cylinders that indicate “Short”. Proceed to Test Step 4.

Test Step 4. Check the Variation of the Injectors between Cylinders

- A. Start the engine.
- B. Allow the engine to warm up to normal operating temperature.
- C. After the engine is warmed to operating temperature, access the “Cylinder Cutout Test” by accessing the following display screens in order:
 - “Diagnostics”
 - “Diagnostic Tests”
 - “Cylinder Cutout Test”
- D. Select the start button at the bottom of the screen for the cylinder cutout test on the electronic service tool.
- E. Select the “Cylinder Cutout Test”.
- F. Follow the instructions that are provided in the cylinder cutout test. The cylinder cutout tests are interactive so the procedure is guided to the finish.

Note: The “Manual Cylinder Cutout Test” is also available. Access the manual test by selecting the “Change” button on the screen for the cylinder cutout test. The “Cylinder Cutout Test” is the recommended starting procedure. The automated tests run twice collecting data. The two sets of data are analyzed and an “OK” or “Not OK” result is displayed.

G. Check for active diagnostic codes and for logged diagnostic codes that are related to the injector solenoids.

Expected Result:

All cylinders indicate “OK” on the electronic service tool.

Results:

- OK – All cylinders indicate “OK”.

Repair: If the engine is misfiring or if the engine has low power, refer to Troubleshooting, “Engine Misfires, Runs Rough or Is Unstable” and Troubleshooting, “Low Power/Poor or No Response to Throttle”.

If a diagnostic code results from running the cylinder cutout test, proceed to Test Step 5.

- Not OK – One or more cylinders displayed “Not OK” during the test. Proceed to Test Step 5.

Test Step 5. Check the Harness between the ECM and the Valve Cover Base for an Open Circuit



Electrical shock hazard. The electronic unit injector system uses 67-73 volts.

- A. Turn the keyswitch to the OFF position. A strong electrical shock hazard is present if the keyswitch is not turned OFF.
- B. Disconnect the connectors from the valve cover base.
- C. Turn the keyswitch to the ON position.
- D. Fabricate a jumper wire 100 mm (4 inch) long with terminals on both ends of the wire.
- E. Insert one end of the jumper wire into the terminal for the suspect injector's supply. Insert the other end of the jumper wire into the terminal for the suspect injector's return circuit.
- F. Perform the “Injector Solenoid Test” at least two times.

G. Repeat this test for each suspect injector. Stop the “Injector Solenoid Test” before handling the jumper wires.

Expected Result:

The electronic service tool displays “Current Above Normal” for the cylinder with the jumper wire.

Results:

- OK – The harness between the ECM and the valve cover base is OK. Proceed to Test Step 6.
- Not OK – There is a fault between the ECM and the valve cover base. Proceed to Test Step 7.

Test Step 6. Check the Injector Harness Under the Valve Cover



Electrical shock hazard. The electronic unit injector system uses 67-73 volts.

- Turn the keyswitch to the OFF position. A strong electrical shock hazard is present if the keyswitch is not turned OFF.
- Remove the valve cover.
- On six cylinder engines, disconnect the harness from the suspect injector. Disconnect the harness from the injectors that share the same supply circuit as the suspect injector.

Note: On six cylinder engines, injectors 1, 2, and 3 share a common injector driver circuit in the ECM. Injectors 4, 5, and 6 share a common injector driver circuit in the ECM. If the three injectors that share a common supply indicate “Open Circuit” fault codes, the open circuit is probably caused by a faulty ECM.

- Thoroughly clean the terminals on the injectors and on the harness connectors.
- Exchange the harness between two of the injectors that share the common driver.
- Turn the keyswitch to the ON position.
- Perform the “Injector Solenoid Test” at least two times.

Expected Result:

Exchanging the harness between the two injectors caused the fault to move to the other injector.

Results:

- OK – There is a fault with the injector harness under the valve cover.

Repair: Repair the injector harness or replace the injector harness under the valve cover.

Use the electronic service tool in order to clear all logged diagnostic codes and then verify that the repair eliminates the fault.

STOP.

- Not OK – The injector may be faulty.

Repair: Replace the faulty injector.

Restore the wiring to the correct injectors.

Perform the “Injector Solenoid Test”.

Use the electronic service tool in order to clear all logged diagnostic codes and then verify that the repair eliminates the fault.

STOP.

Test Step 7. Check the ECM for an Open Circuit



Electrical shock hazard. The electronic unit injector system uses 67-73 volts.

- Turn the keyswitch to the OFF position. A strong electrical shock hazard is present if the keyswitch is not turned OFF.
- Disconnect connector P2 from the ECM.
- Remove the supply wire and the return wire for the suspect injector from connector P2. Install a jumper wire into connector P2 in order to provide a short between the supply and the return of the suspect injector.
- Reinstall connector P2 to the ECM.
- Turn the keyswitch to the ON position.
- Perform the “Injector Solenoid Test” at least two times.

Expected Result:

The electronic service tool displays “Current Above Normal” for the cylinder with the jumper wire.

Note: On four cylinder engines, shorting a shared supply will affect the status of two injectors. Ignore the status of the other injector that is on the shared supply.

Note: On six cylinder engines, shorting a shared supply will affect the status of three injectors. Ignore the status of the other injectors that are on the shared supply.

Results:

- OK – The ECM is OK.

Repair: On six cylinder engines, if the three injectors that share a supply indicate “Open Circuit” fault codes, the open circuit is probably caused by a faulty ECM.

Repair the engine harness or replace the engine harness, as required.

Use the electronic service tool in order to clear all logged diagnostic codes and then verify that the repair eliminates the fault.

STOP.

- Not OK – There may be a fault with the ECM.

Repair: Perform the following procedure:

1. Make sure that the latest flash file for the application is installed in the ECM. Refer to Troubleshooting, “Flash Programming”.
2. Remove the jumper wire from connector P2 and reinstall the injector wires.
3. Contact the Technical Help Desk.

Note: This consultation can greatly reduce the repair time.

4. If the Technical Help Desk recommends the use of a test ECM, install a test ECM. Refer to Troubleshooting, “Replacing the ECM”.
5. Perform the “Injector Solenoid Test”.
6. If the fault is resolved with the test ECM, reconnect the suspect ECM.
7. If the fault returns with the suspect ECM, replace the ECM.
8. Use the electronic service tool in order to clear all logged diagnostic codes and then verify that the repair eliminates the fault.

STOP.

Test Step 8. Check the Harness between the ECM and the Valve Cover Base for a Short Circuit



Electrical shock hazard. The electronic unit injector system uses 67-73 volts.

- A. Turn the keyswitch to the OFF position. A strong electrical shock hazard is present if the keyswitch is not turned OFF.
- B. Disconnect the connectors from the valve cover base.
- C. Turn the keyswitch to the ON position.
- D. Perform the “Injector Solenoid Test” at least two times.

Expected Result:

All cylinders indicate “Current Below Normal”.

Results:

- OK – All cylinders indicate “Current Below Normal”. Proceed to Test Step 10.
- Not OK – One or more cylinders indicate “Current Above Normal”. Note the cylinders that indicate “Current Above Normal”. Proceed to Test Step 9.

Test Step 9. Check the ECM for a Short Circuit



Electrical shock hazard. The electronic unit injector system uses 67-73 volts.

- A. Turn the keyswitch to the OFF position. A strong electrical shock hazard is present if the keyswitch is not turned OFF.
- B. Disconnect connector P2 from the ECM and check for evidence of moisture entry.
- C. Turn the keyswitch to the ON position.
- D. Perform the “Injector Solenoid Test” at least two times.

Expected Result:

All cylinders indicate “Current Below Normal” when connector P2 is disconnected from the ECM.

Note: When the engine harness is disconnected, all of the diagnostic codes for supply voltage to the sensors will be active. This is normal. Clear all of the logged diagnostic codes after completing this test step.

Results:

- OK – The short circuit is in the engine harness.

Repair: The fault is most likely in one of the wires to the injector. Inspect the connectors for moisture and for corrosion. Also, check the wire insulation for damage and for strands that are exposed.

Repair the engine harness or replace the engine harness, as required. Clear all diagnostic codes after completing this test step.

Use the electronic service tool in order to clear all logged diagnostic codes and then verify that the repair eliminates the fault.

STOP.

- Not OK – There may be a fault with the ECM.

Repair: Perform the following procedure:

1. Make sure that the latest flash file for the application is installed in the ECM. Refer to Troubleshooting, “Flash Programming”.
2. Contact the Technical Help Desk.

Note: This consultation can greatly reduce the repair time.

3. If the Technical Help Desk recommends the use of a test ECM, install a test ECM. Refer to Troubleshooting, “Replacing the ECM”.
4. Perform the “Injector Solenoid Test”.
5. If the fault is resolved with the test ECM, reconnect the suspect ECM.
6. If the fault returns with the suspect ECM, replace the ECM.
7. Use the electronic service tool in order to clear all logged diagnostic codes and then verify that the repair eliminates the fault.

STOP.

Test Step 10. Check the Engine Harness Under the Valve Cover for a Short Circuit



Electrical shock hazard. The electronic unit injector system uses 67-73 volts.

- A. Turn the keyswitch to the OFF position. A strong electrical shock hazard is present if the keyswitch is not turned OFF.
- B. Remove the valve cover.
- C. Disconnect each of the injectors that indicate a “Short” from the wiring harness. Ensure that each of the connectors from the disconnected injector harness does not touch any other components.
- D. Turn the keyswitch to the ON position.
- E. Perform the “Injector Solenoid Test” at least two times.

Expected Result:

All of the injectors that were disconnected indicate “Current Below Normal”.

Results:

- OK – All of the injectors that were disconnected indicate “Current Below Normal”.

Repair: Leave the injector wires disconnected. The supply wire is not shorted to the engine.

Proceed to Test Step 11.

- Not OK – One or more of the injectors that were disconnected indicate “Current Above Normal”.

Repair: The fault is most likely in the supply to the injector. Inspect the connectors for moisture and for corrosion. Also, check the supply wire’s insulation for damage and for strands that are exposed.

Repair the injector harness or replace the injector harness under the valve cover.

Use the electronic service tool to clear all logged diagnostic codes and then verify that the repair has eliminated the fault.

STOP.

Test Step 11. Check for a Short Circuit in the Return Wire



Electrical shock hazard. The electronic unit injector system uses 67-73 volts.

- A. Turn the keyswitch to the OFF position. A strong electrical shock hazard is present if the keyswitch is not turned OFF.
- B. Disconnect the connector P2 from the ECM.
- C. Locate the terminal for the supply of the faulty injector in the connector P2. Measure the resistance from the terminal to the engine ground stud.

Expected Result:

The resistance is greater than 10 Ohms.

Results:

- OK – The resistance is greater than 10 Ohms.

Repair: Reconnect connector P2.

Replace the faulty injector.

Perform the “Injector Solenoid Test”.

Use the electronic service tool in order to clear all logged diagnostic codes and then verify that the repair eliminates the fault.

STOP.

- Not OK – There is a short in the return line.

Repair: Disconnect the connectors from the valve cover base.

Measure the resistance of the return wire between connector P2 and the engine ground stud.

If the resistance is less than 10 Ohms, the fault is in the return wire between the ECM and the valve cover base.

If the resistance is greater than 10 Ohms, the fault is in the return wire under the valve cover.

Repair the injector harness or replace the injector harness.

Use the electronic service tool to clear all logged diagnostic codes and then perform the “Injector Solenoid Test” in order to verify that the repair eliminates the fault.

STOP.

i04012490

Speed Control (PWM) - Test

System Operation Description:

The use of a Throttle Position Sensor (TPS) eliminates the need for a mechanical throttle and governor linkages. The TPS converts a lever movement by the operator into an electrical signal. The electrical signal is sent to the engine's Electronic Control Module (ECM). The ECM processes the signal in order to control the engine speed.

A Pulse Width Modulated signal (PWM) is created by the TPS. The duty cycle varies with the throttle position. The signal has a low duty cycle when the throttle is at low idle. The signal has a high duty cycle when the throttle is at high idle.

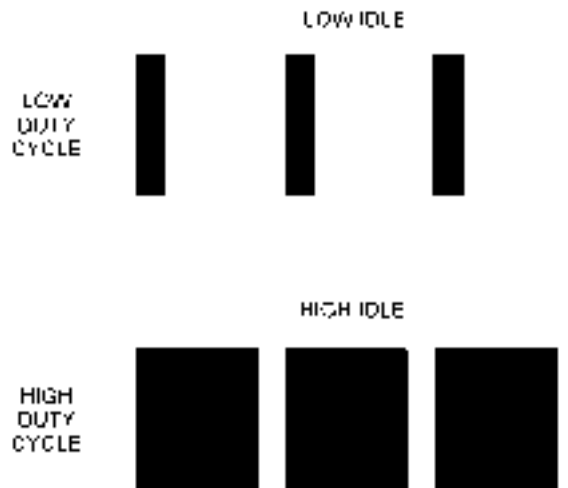

Illustration 81

g01122143

Duty cycle versus throttle position

The signal that is produced by the TPS has a variable frequency. The frequency of the signal must be between 150 Hz and 1050 Hz or the ECM will activate an -08 diagnostic code. Use this procedure to troubleshoot these diagnostic codes:

- 91-08 Throttle Position signal abnormal
- 774-08 Secondary Throttle Position signal abnormal

A problem with the circuit for the synchronization switch may prevent the ECM from responding to a valid signal from the TPS. The following active diagnostic codes will also prevent the ECM from responding to the throttle input:

- 91-13 Throttle Position Calibration required
- 268-02 Check Programmable Parameters
- 774-13 Secondary Throttle Position Calibration required

If one of the above diagnostic codes is active, troubleshoot that code before you continue with this procedure.

This troubleshooting procedure verifies that the signal from a TPS is valid at the ECM.

If necessary, make repairs to the circuit for the TPS.

Two throttle position sensors are shown in Illustration 82. A vessel may contain more than one TPS. Each TPS may be connected to more than one ECM. Refer to the vessel's schematic diagram for the actual configuration. Use this procedure to troubleshoot all possible configurations.

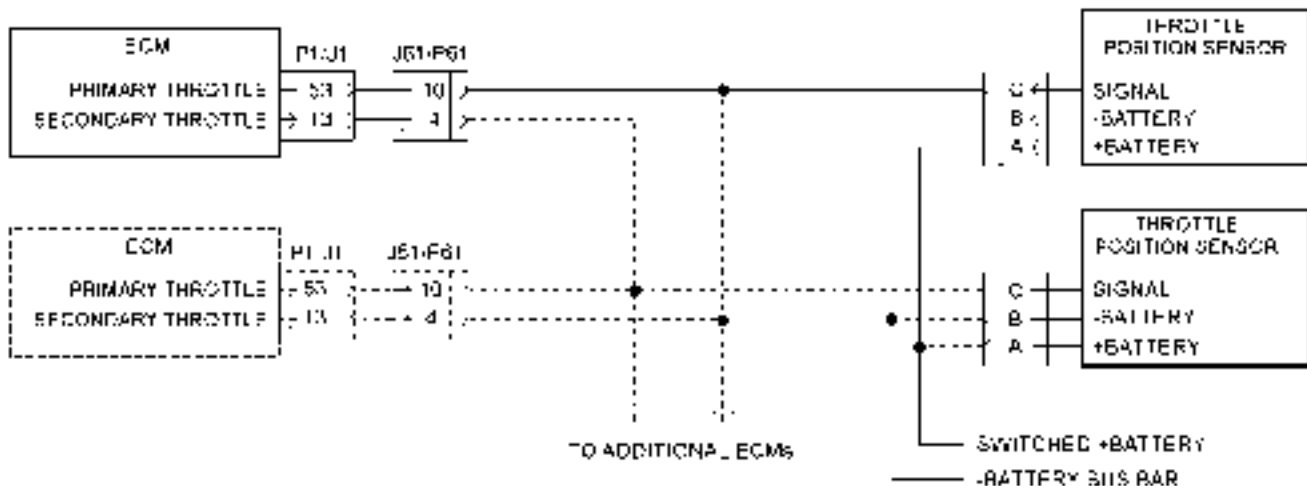

Illustration 82

g02192034

Typical schematic for the throttle position sensor

Test Step 1. Verify that the “Secondary Throttle Enable” Parameter is Programmed Correctly

- Connect the electronic service tool to the service tool connector.
- Establish communication with the ECM that activated the 08 diagnostic code.
- Verify that the “Secondary Throttle Enable” status is programmed correctly.
 - If the engine is equipped with a single TPS, verify that the “Secondary Throttle Enable” parameter is programmed to “Disabled”.

- b. If the engine is equipped with multiple throttle position sensors, verify that the “Secondary Throttle Enable” parameter is programmed to “Enabled”.

Expected Result:

The “Secondary Throttle Enable” parameter is programmed correctly.

Results:

- OK – The “Secondary Throttle Enable” parameter is programmed correctly. Proceed to Test Step 2.
- Not OK – The “Secondary Throttle Enable” parameter is not programmed correctly.

Repair: Program the “Secondary Throttle Enable” parameter to the correct value.

Verify that the repair eliminates the problem.

STOP.

Test Step 2. Inspect the Electrical Connectors and the Wiring

- A. Remove the electrical power from the ECM.
- B. Thoroughly inspect the ECM connector and the customer connector. Inspect the connections on each throttle position sensor. Refer to diagnostic functional tests Troubleshooting, “Electrical Connectors - Inspect”.

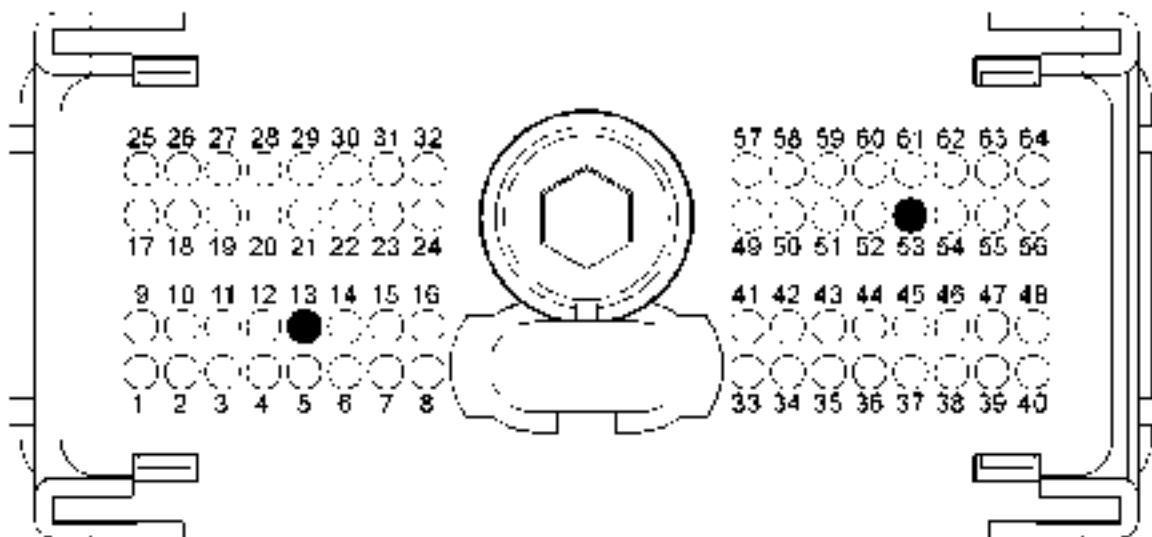

Illustration 83

P1 terminals that are associated with the throttle position sensor

(P1-53) Primary throttle position

(P1-13) Secondary throttle position

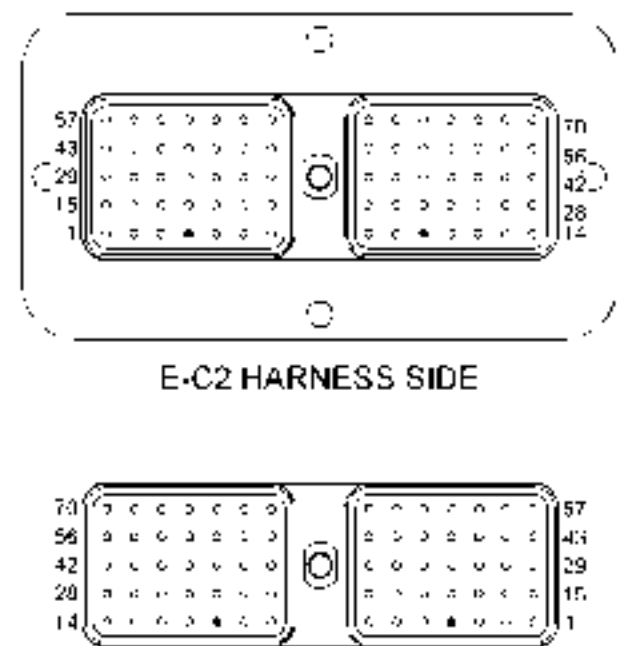

Illustration 84

g02201013

Terminals that are associated with the throttle position sensor

- (10) Primary throttle position
(4) Secondary throttle position

- C.** Perform a 45 N (10 lb) pull test on each of the wires that are associated with the throttle position sensor.
- D.** Check the allen head screw on the customer connector and on each ECM connector for the proper torque. Refer to diagnostic functional tests Troubleshooting, "Electrical Connectors - Inspect" for the correct torque values.
- E.** Check the harness and wiring for abrasions and for pinch points from each throttle position sensor to the ECM and from the throttle position sensor to the electrical power source.

Expected Result:

All connectors, pins, and sockets are completely coupled and/or inserted, and the harness and wiring are free of corrosion, of abrasion or of pinch points.

Results:

- OK – The wiring and the connectors appear to be OK. Proceed to Test Step 3.
- Not OK – There is a problem with the wiring and/or the connectors.

Repair: Repair the wiring and/or the connectors. Replace parts, if necessary. Ensure that all of the seals are properly connected. Verify that the repair eliminates the problem.

STOP.

Test Step 3. Check for Supply Voltage at the Throttle Position Sensor

- A.** Disconnect the harness connector from the suspect throttle position sensor.
- B.** Restore the electrical power to the ECM.
- C.** Measure the voltage between terminals A and B on the harness connector for the throttle position sensor.

Expected Result:

The supply voltage is at least 11 VDC for a 12 volt system. The supply voltage is at least 22 VDC for a 24 volt system.

Results:

- OK – The supply voltage is at least 11 VDC for a 12 volt system. The supply voltage is at least 22 VDC for a 24 volt system. The supply voltage is reaching the sensor. Proceed to Test Step 4.
- Not OK – The supply voltage is incorrect.

Repair: The configuration of the wiring between the battery and the throttle position sensor depends on the vessel's configuration. The problem could be in the wiring or in a connector. There may be a problem with the battery.

Perform the necessary repairs. Verify that the problem is resolved.

STOP.

Test Step 4. Check the Signal Wire for a Short Circuit

- A.** Remove the electrical power from the ECM.
- B.** Disconnect the P1 connector from every ECM on the vessel. Verify that the electrical connector for the suspect throttle position sensor is disconnected.

Note: Be sure to wiggle the harnesses during the following measurements. Be sure to wiggle each harness near each connector.

- C.** Measure the resistance between terminal P1-53 and all of the other terminals in the P1 connector for the ECM that activated the -08 diagnostic code.

Expected Result:

Each resistance measurement indicates an open circuit.

Results:

- OK – Each resistance measurement indicates an open circuit. Connect the P1 connectors. Proceed to Test Step 6.
- Not OK – At least one resistance measurement does not indicate an open circuit.

Repair: There is a problem with the signal wire for the throttle position sensor. The problem could be in the wiring or in a connector. Repair the wiring and/or the connector, when possible. Replace parts, if necessary. Verify that the problem is resolved.

STOP.

Test Step 5. Check the Signal Wire for an Open Circuit

Note: Be sure to wiggle the harnesses during the following measurement. Be sure to wiggle each harness near each connector.

Measure the resistance between terminal P1-53 for the ECM that activated the 08 diagnostic code and terminal C of the harness connector for the suspect TPS.

Expected Result:

The resistance measurement is less than ten Ohms.

Results:

- OK – The resistance measurement is less than ten Ohms. Connect all of the electrical connectors. Proceed to Test Step 6.
- Not OK – The resistance measurement is greater than ten Ohms. There is a problem with the signal wire.

Repair: The problem could be in the wiring or in a connector. Repair the wiring and/or the connector, when possible. Replace parts, if necessary. Verify that the problem is resolved.

STOP.

Test Step 6. Check the Frequency of the Throttle Position Signal at the Sensor

A. Connect the electronic service tool to the service tool connector. Refer to electronic troubleshooting Troubleshooting, “Electronic Service Tools”.

B. Connect a breakout T between the harness connectors (3 pin) for the throttle position sensor.

C. Connect a multimeter between terminals B and C on the breakout T.

D. Restore the electrical power to the ECM.

E. Measure the frequency of the throttle position signal. Slowly move the throttle from low idle to high idle and back to low idle while you measure the frequency of the signal.

F. Use electronic service tool to check for active diagnostic codes. Slowly move the throttle from the low idle position to the high idle position. Look for an 08 diagnostic code while you move the throttle.

Expected Result:

The frequency of the signal remains between 150 Hz and 1050 Hz as you move the throttle. An -08 diagnostic code is not activated.

Results:

- OK – The frequency of the signal remains between 150 Hz and 1050 Hz as you move the throttle. An 08 diagnostic code is not activated.

Repair: Perform the following procedure:

1. Remove the electrical power from the ECM.
2. Remove the breakout T.
3. Connect the harness connectors for the throttle position sensor.
4. Restore the electrical power to the ECM.
5. Operate the throttle throughout the entire range.

If the problem does not recur, the problem is resolved. The original problem was probably caused by a poor electrical connection. Return the engine to service.

STOP.

- Not OK – The frequency of the signal is incorrect. A 91-08 diagnostic code is activated.

Repair: Perform the following procedure:

1. Remove the electrical power from the ECM.
2. Replace the throttle position sensor. Check for an 08 diagnostic code again.

If the diagnostic code does not recur, the problem is resolved. Return the engine to service.

If the diagnostic code recurs, replace the ECM. Refer to electronic troubleshooting Troubleshooting, "Replacing the ECM". Verify that the problem is resolved.

This glow plug start aid override test switches on the cold starting aid when the engine is not running. The glow plug start aid override test aids the analysis of the circuit for the glow plug start aid relay.

STOP.

i04012449

Starting Aid (Glow Plug) Relay Circuit - Test

System Operation Description:

Note: If codes 0897-05 Glow Plug Start Aid Relay 2 Current below normal and 0897-06 Glow Plug Start Aid Relay 2 Current above normal are displayed, contact the Global Technical Support Center.

Use this procedure if another test procedure has directed you here.

Use this procedure for the following diagnostic codes:

- 2246-05 Glow Plug Start Aid Relay Current below normal
- 2246-06 Glow Plug Start Aid Relay Current above normal

The following background information is related to this procedure:

The starting aid is used to improve the engine starting when the engine is cold. With the keyswitch in the ON position, the engine Electronic Control Module (ECM) will monitor the coolant temperature and the intake manifold air temperature in order to determine if the glow plugs are required to be switched ON. If the glow plugs are required, then the ECM activates the starting aid relay for a controlled time period. While the glow plug start aid relay is energized the glow plug start aid relay will switch power to the glow plugs. If a "Wait To Start" lamp is installed, the lamp will be illuminated in order to indicate the "Wait To Start" period.

Electronic Service Tool

The electronic service tool includes the test "Glow Plug Start Aid Override Test". The "Glow Plug Start Aid Override Test" will assist the analysis of the cold starting aid.

Overview of the Glow Plug Start Aid Override Test

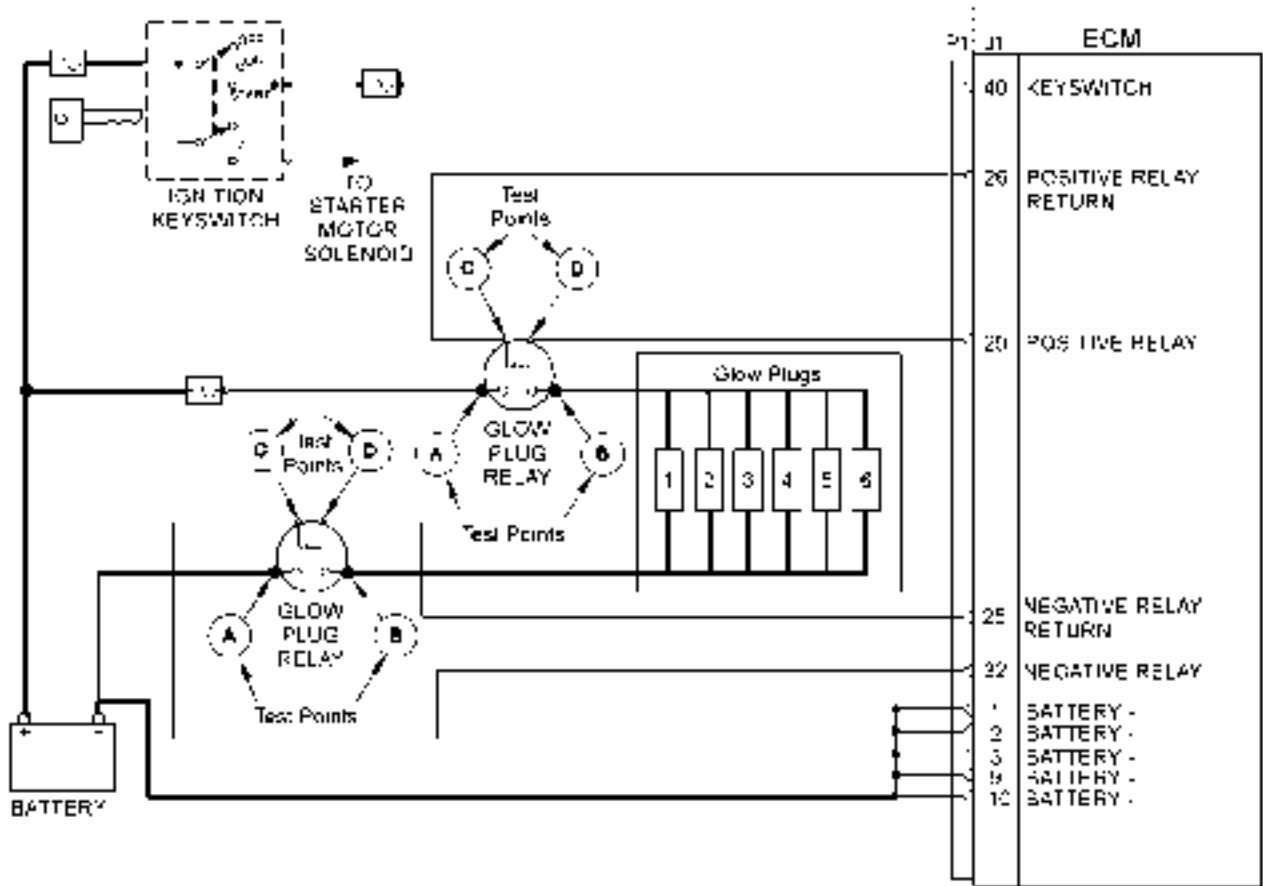

Illustration 85
Typical schematic for the starting aid switch

g02192011

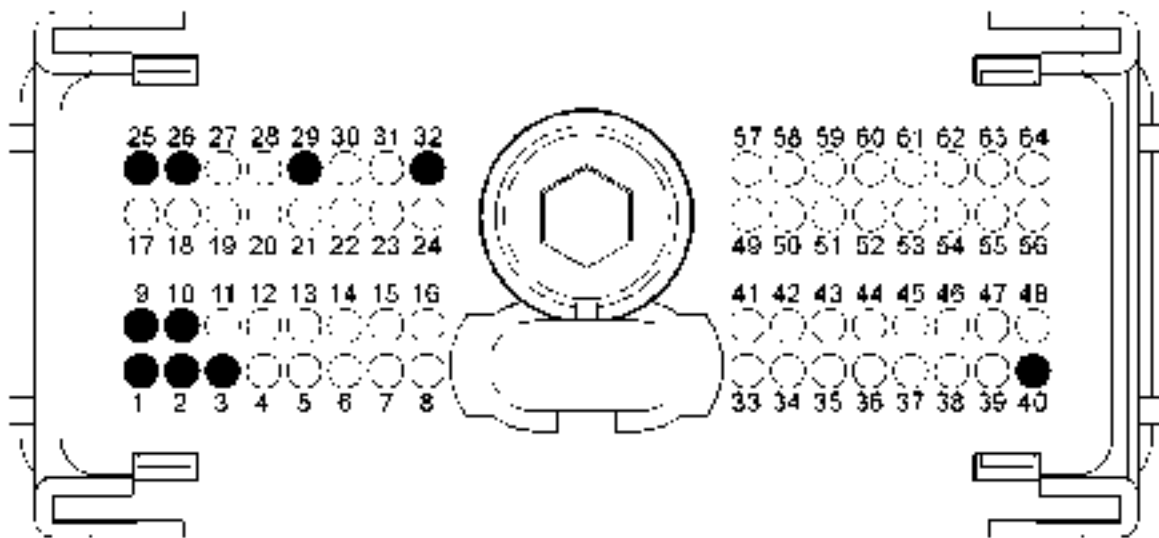

Illustration 86
Typical view of the pin locations on the P1 connector

g02192012

- | | | |
|------------------|----------------------------|---------------------|
| (1) Ground (GND) | (10) Ground (GND) | (32) Negative relay |
| (2) Ground (GND) | (25) Negative relay return | (40) Keyswitch |
| (3) Ground (GND) | (26) Positive relay return | |
| (9) Ground (GND) | (29) Positive relay | |

Test Step 1. Inspect Electrical Connectors and Wiring

A. Inspect the following connectors:

- P1 connector
- P2 connector

B. Inspect the terminal connections on the glow plug start aid relay. Refer to Troubleshooting, “Electrical Connectors - Inspect” for details.

C. Perform a 45 N (10 lb) pull test on each of the wires in the ECM connector that are associated with the glow plug starting aid.

D. Check the screw for the ECM connector for the correct torque of 5.0 N·m (44 lb in).

E. Check the harness for abrasion and pinch points from the glow plugs back to the ECM.

F. Check that the fuses are not blown.

Expected Result:

All connectors, pins, and sockets are correctly coupled and/or inserted. The harness is free of corrosion, abrasion, and pinch points. The fuses are not blown.

Results:

- OK – The harness and the connectors appear to be OK. Proceed to Test Step 2.
- Not OK – There is a fault with the harness and connectors.

Repair: Repair the connectors or the harness or replace the connectors or the harness. Ensure that all of the seals are correctly installed and ensure that the connectors are completely coupled. Replace blown fuses.

Use the electronic service tool in order to clear all logged diagnostic codes and then verify that the repair has eliminated the fault.

STOP.

Test Step 2. Check for Active Diagnostic Codes

A. Connect the electronic service tool to the diagnostic connector.

B. Turn the keyswitch to the ON position. Do not start the engine.

C. Use the electronic service tool to select the “Glow Plug Override Test” in order to turn on the power for the glow plugs.

D. Check for active diagnostic codes or recently logged diagnostic codes.

Expected Result:

The following diagnostic code is active or recently logged:

- 2246-05 Glow Plug Start Aid Relay Current below normal
- 2246-06 Glow Plug Start Aid Relay Current above normal

Results:

- OK – The expected diagnostic code is active or recently logged. Proceed to Test step 3.
- Not OK – An active diagnostic code or a recently logged diagnostic code was not displayed.

Repair: Perform one of the following procedures:

- If an intermittent fault is suspected, use the electronic service tool to perform a “Wiggle Test” in order to locate intermittent connections.
- If there is a fault on the glow plug or a fault on the starting aid and a diagnostic code is not displayed, there may be a fault with the glow plug switched power circuit or there may be an open circuit in the relay coil circuit. The ECM does not monitor the status of these items. Refer to Testing and Adjusting, “Glow Plugs - Test”.

STOP.

Test Step 3. Check the Wiring for a Short Circuit

A. Turn the keyswitch to the OFF position.

B. Remove the P1 connector from the ECM.

C. Check the connector, pins, and the sockets for corrosion or damage.

D. Check the resistance between P1:29 or P1:32 and each of the pins on the P1 connector.

Expected Result:

The resistance between P1:29 or P1:32 and each of the pins on the P1 connector is more than 10,000 Ohms.

Results:

- OK – The harness connects the ECM to the glow plug start aid relay and there are no shorts to other circuits. The ECM or the glow plug start aid relay is suspect. Proceed to Test Step 4.

- Not OK – The harness is faulty.

Repair: If the resistance between P1:29 or P1:32 and each of the other pins on the P1 connector is less than 10,000 Ohms then there is a short circuit or high resistance in the connection to another wire. Locate the open circuit, the short circuit, or high resistance in the connection in the harness. Repair the connectors or the harness and/or replace the connectors or the harness. Ensure that all of the seals are correctly in place and ensure that the connectors are correctly coupled. Replace any fuses that may be open circuit.

Use the electronic service tool in order to clear all logged diagnostic codes and then verify that the repair has eliminated the fault.

If the fault still exists, proceed to Test Step 4.

Test Step 4. Bypass the ECM In Order to Check the Operation of the Glow Plug Start Aid Relay

- Turn the keyswitch to the OFF position.
- Disconnect the connection from test point “D” on the glow plug start aid relay.
- Connect a jumper wire between the battery ground and terminal “D” on the glow plug start aid relay.
- Measure the voltage from the battery ground and terminal “B” on the glow plug start aid relay.
- Connect a multimeter between terminal “B” on the glow plug start aid relay and the battery ground.
- Turn the keyswitch to the ON position.

Note: The engine has not been started at this Test Step.

- Use the electronic service tool in order to operate the glow plugs.
- Measure the voltage from the battery ground and terminal “B” on the glow plug start aid relay.

Expected Result:

The keyswitch is in the OFF position. The voltage should be 0 VDC.

The keyswitch is in the ON position. The measured voltage for the 12 Volt systems is a constant 10.5 to 13.5 VDC. The measured voltage for the 24 Volt systems is a constant 21.0 to 27.0 VDC.

Results:

- OK – The glow plug start aid relay is operating correctly. Reconnect the connection to test point “D” on the glow plug start aid relay. Proceed to Test Step 5.

- Not OK – The glow plug start aid relay is faulty.

Repair: Replace the glow plug start aid relay. Use the electronic service tool in order to clear all logged diagnostic codes and then verify that the repair eliminates the fault.

If the fault still exists, proceed to Test step 5.

Test Step 5. Check the ECM

- Make sure that the latest flash file for the application is installed in the ECM. Refer to Troubleshooting, “Flash Programming”.

- Contact the Global Technical Support Center.

Note: This consultation can greatly reduce the repair time.

- If the Global Technical Support Center recommends the use of a test ECM, install a test ECM. Refer to Troubleshooting, “Replacing the ECM”.

- Use the electronic service tool in order to perform a “Glow Plug Override Test”.

- If the fault is resolved with the test ECM, reconnect the suspect ECM.

Expected Result:

The replacement ECM functions correctly. Performing the “Glow Plug Override Test” energizes the glow plugs. The fault returns with the suspect ECM.

Results:

- OK – The replacement ECM functions correctly.

Repair: Install the replacement ECM. Refer to Troubleshooting, “Replacing the ECM”.

Use the electronic service tool in order to clear all logged diagnostic codes and then verify that the repair eliminates the fault.

STOP.

i04011089

Switch Circuits - Test

System Operation Description:

Switch circuits may have problems such as faulty wiring, faulty switches, or faulty connectors. Use the following diagnostic procedures in order to diagnose problems with these switch circuits and repair these switch circuits:

- “Trolling mode switch”
- “Slow vessel mode switch”
- “Maintenance clear switch”
- “Trip clear switch”
- “Remote shutdown switch”
- “Synchronize switch 1”
- “Synchronize switch 2”

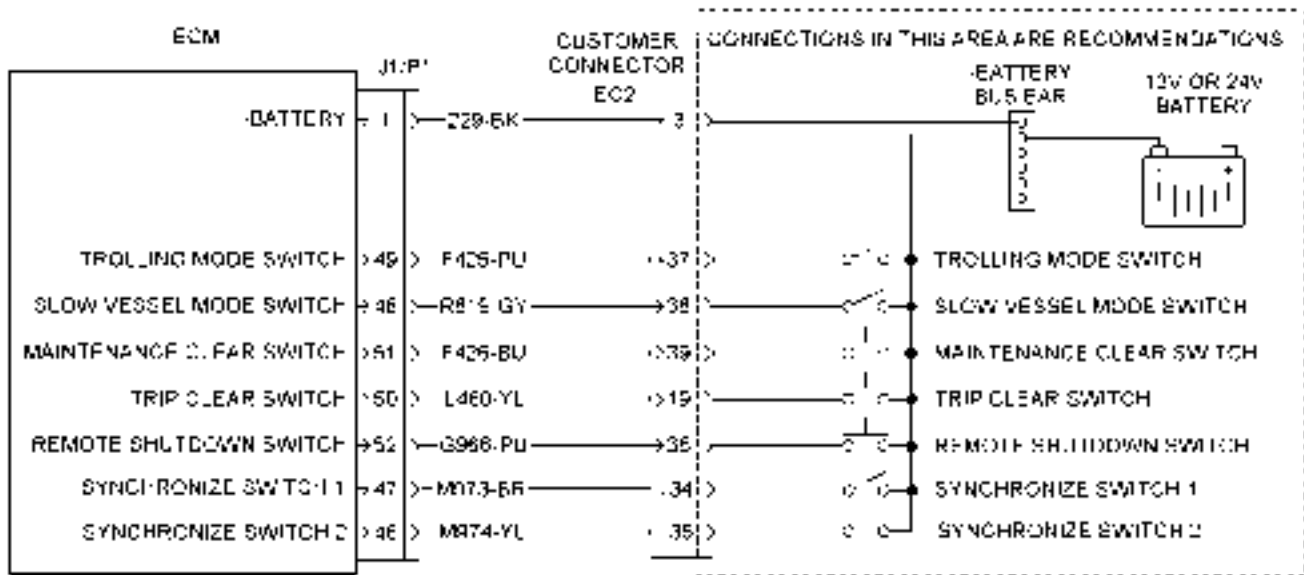

Illustration 87
Schematic for the switch inputs

g02191991

Test Step 1. Check the Electrical Connectors and the Wiring

- Remove the electrical power from the ECM.
- Thoroughly inspect the ECM connector and the customer connector. Thoroughly inspect the connections for the suspect switch. Refer to the diagnostic functional test Troubleshooting, “Electrical Connectors - Inspect”.

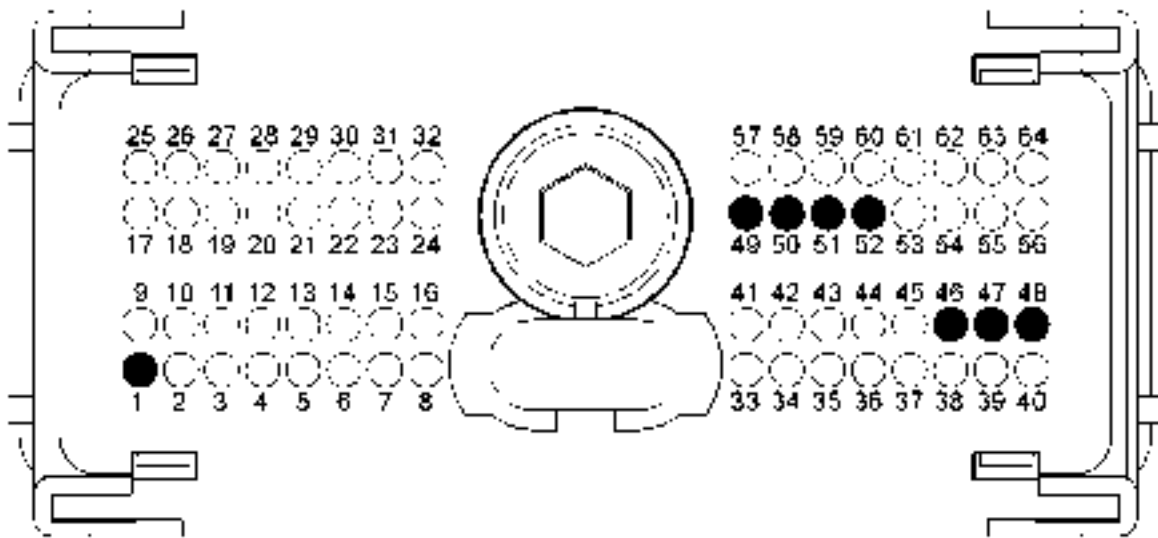

Illustration 88

g02191993

P1 terminals for the various switches

(P1-1) "Negative Battery"

(P1-52) "Remote shutdown switch"

(P1-51) "Maintenance clear switch"

(P1-50) "Trip clear switch"

(P1-49) "Trolling mode switch"

(P1-48) "Slow vessel mode switch"

(P1-47) "Synchronize switch 1"

(P1-46) "Synchronize switch 2"

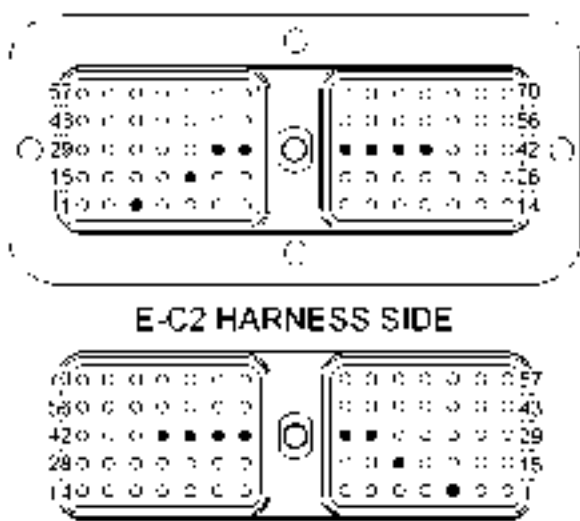

Illustration 89

g02247954

E-C2 terminals that are associated with the switch inputs

(3) -Battery

(19) "Trip clear switch"

(36) "Remote shutdown switch"

(37) "Trolling mode switch"

(38) "Slow vessel mode switch"

(39) "Maintenance clear switch"

(34) "Synchronize switch 1"

(35) "Synchronize switch 2"

C. Perform a 45 N (10 lb) pull test on each of the wires in the circuit for the suspect switch.

D. Check the allen head screw on the connector for the Electronic Control Module (ECM) for the proper torque. Refer to the diagnostic functional test Troubleshooting, "Electrical Connectors - Inspect" for the correct torque values.

E. Check the allen head screw on the customer connector for the proper torque. Refer to the diagnostic functional test Troubleshooting, "Electrical Connectors - Inspect".

F. Check the harness and wiring for abrasions and for pinch points from the battery to the ECM.

Expected Result:

All connectors, pins, and sockets are completely coupled and/or inserted, and the harness and wiring are free of corrosion, of abrasion or of pinch points.

Results:

- OK – The wiring and connectors are OK. Proceed to Test Step 2.
- Not OK – There is a problem with the wiring and/or a connector.

Repair: Repair the wiring and/or the connector. Replace parts, if necessary. Ensure that all of the seals are properly connected. Verify that the repair eliminates the problem.

STOP.

Test Step 2. Test the Switch for Proper Operation

- A. Disconnect the P1 connector.
- B. Refer to Table 34. Determine the P1 terminal for the suspect switch.

Table 34

Terminals for the Switch Inputs		
Name of the Switch	P1 Terminals	E-C2 Terminals
"Trolling mode switch"	49	37
"Slow vessel mode switch"	48	38
"Maintenance clear switch"	51	39
"Trip clear switch"	50	19
"Remote shutdown switch"	52	36
"Synchronize switch 1"	47	34
"Synchronize switch 2"	46	35

- C. Connect a meter lead to the P1 terminal for the suspect switch. Connect the other meter lead to engine ground.

Note: Wiggle the harnesses during the following measurements in order to reveal any intermittent conditions.

- D. Measure the resistance between the P1 terminal for the suspect switch and engine ground.
- E. Activate the switch and measure the resistance again.

Expected Result:

When the switch is not activated, the resistance measurement indicates an open circuit. When the switch is activated, the resistance measurement indicates a short circuit.

Results:

- OK – When the switch is not activated, the resistance measurement indicates an open circuit. When the switch is activated, the resistance measurement indicates a short circuit. The switch is operating correctly. The wiring does not have a short circuit or an open circuit.

Repair: Operate the engine and check the switch for proper operation.

If the switch does not operate correctly, there may be a short circuit between the circuit for the suspect switch and another circuit. Carefully reinspect the components. Refer to the diagnostic functional test Troubleshooting, "Electrical Inspectors - Inspect". Locate the short circuit and make repairs.

STOP.

- Not OK – Both resistance measurements indicate an open circuit or both resistance measurements indicate a short circuit. There is a problem with the circuit for the switch.

Repair: The problem could be in the switch, in the wiring, or in a connector.

Carefully reinspect the components. Refer to the diagnostic functional test Troubleshooting, "Electrical Inspectors - Inspect".

If the inspection does not identify the faulty component, replace the switch and test the switch again.

If the problem is not resolved, repair the wiring or the connector. Replace parts, if necessary. Verify that the problem is resolved.

STOP.

i04013629

Throttle Position Sensor - Test

Test Step 1. Check the Throttle for Proper Operation

- A. Remove the electrical power from the ECM.
- B. Inspect the throttle linkage for components with the following conditions:

- Loose
- Bent
- Broken
- Missing
- Worn

Note: The sensor stops are not intended to be the primary means of limiting the travel of the throttle. If you apply excessive force to the sensor stops you will damage the sensor assembly.

- C. Move the throttle throughout the entire range. The throttle should move without binding and without excessive drag.

Expected Result:

The throttle linkage is in good condition. The throttle moves without binding and without excessive drag.

Results:

- OK – The throttle linkage is in good condition. The throttle operates properly. Proceed to Test Step 2.
- Not OK – One of the following conditions exist: The throttle linkage is not in good condition. The throttle binds or the throttle has excessive drag.

Repair: Identify the source of the mechanical problem and make repairs. Replace parts, if necessary.

Proceed to Test Step 2 when the throttle operates properly.

Test Step 2. Adjust the Throttle Linkage for the Low Idle Position

- A. Connect the electronic service tool to the service tool connector.
- B. Restore the electrical power to the ECM. Do not start the engine.
- C. Place the throttle in the low idle position.
- D. Observe the duty cycle for the throttle position sensor on the electronic service tool.

Note: Adjustment of the sensor stops is not necessary.

- E. Adjust the throttle linkage in order to achieve a 5 to 10 percent duty cycle while the throttle is in the low idle position.

Expected Result:

The duty cycle is between five and ten percent when the throttle is in the low idle position.

Results:

- OK – The duty cycle is between five and ten percent when the throttle is in the low idle position. Proceed to Test Step 3.
- Not OK – The throttle linkage cannot be adjusted in order to obtain a 5 to 10 percent duty cycle when the throttle is in the low idle position. There is a problem with the throttle linkage.

Repair: Repair the throttle linkage. Replace parts, if necessary. Verify that the problem is resolved.

STOP.

Test Step 3. Adjust the Throttle Linkage for the High Idle Position

- A. Place the throttle in the high idle position.

- B. Observe the duty cycle for the throttle position sensor on the electronic service tool.

Note: Adjustment of the sensor stops is not necessary.

- C. Adjust the throttle linkage in order to achieve a 90 to 95 percent duty cycle when the throttle lever is in the high idle position.

Expected Result:

The duty cycle is between 90 to 95 percent when the throttle is in the high idle position.

Results:

- OK – The duty cycle is between 90 to 95 percent when the throttle is in the high idle position.

Repair: Perform the following procedure:

1. Verify that the duty cycle is between five and ten percent when the throttle is in the low idle position.
2. Verify that the duty cycle is between 90 and 95 percent when the throttle is in the high idle position.

If the duty cycle is not correct at either throttle position, repeat this procedure.

If the throttle linkage cannot be adjusted in order to meet the specifications, replace the throttle lever assembly.

Verify that the problem is resolved.

STOP.

- Not OK – The throttle linkage cannot be adjusted in order to obtain a 90 to 95 percent duty cycle when the throttle is in the high idle position. There is a problem with the throttle linkage.

Repair: Repair the throttle linkage. Replace parts, if necessary.

Verify that the problem is resolved.

STOP.

i04012489

Transmission Oil Temperature - Test

System Operation Description:

Use this procedure to troubleshoot any suspect problems with the marine transmission oil temperature sensor.

This procedure covers the following diagnostic codes:

- 177-03 Transmission Oil Temperature open/short to +batt
- 177-04 Transmission Oil Temperature short to ground

Pull-up Voltage

The ECM continuously outputs a pull-up voltage on the circuit for the sensor signal wire. The ECM uses this pull-up voltage in order to detect a problem in the signal circuit. When the ECM detects the presence of a voltage that is above a threshold on the signal circuit, the ECM will generate a 03 diagnostic code for the sensor.

If the sensor is disconnected at the sensor connector, the presence of pull-up voltage at the sensor connector indicates that the wires from the sensor connector to the ECM are OK. If the sensor is disconnected at the sensor connector, the absence of pull-up voltage at the sensor connector indicates a problem in the signal wire. If the sensor is disconnected at the sensor connector and the voltage at the sensor connector is different from pull-up voltage, the signal wire may be shorted to another wire in the harness.

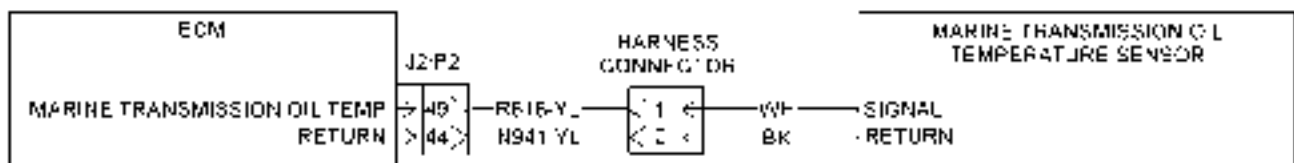

Illustration 90

g02191975

Schematic for the marine transmission oil temperature sensor

Test Step 1. Inspect the Electrical Connectors and the Wiring

- Remove the electrical power from the ECM.
- Thoroughly inspect connectors on the ECM. Inspect the connectors for the sensor. Refer to the diagnostic functional test Troubleshooting, "Electrical Connectors - Inspect".

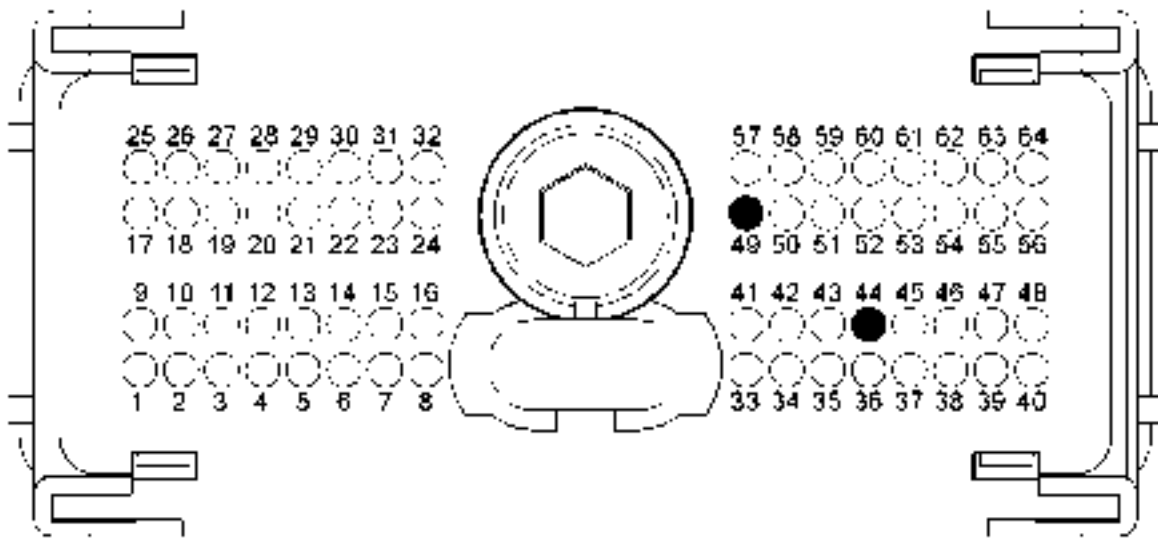

Illustration 91

g02191980

P2 terminals that are associated with the marine transmission oil temperature sensor
(P2-44) Return (P2-49) Marine transmission oil temperature

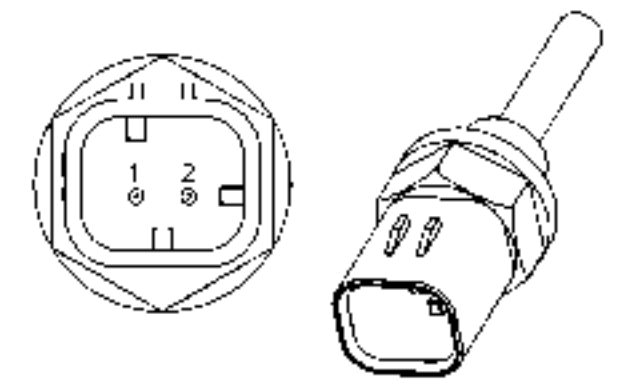

Illustration 92

g01170313

Typical example of marine transmission oil temperature sensor

- (1) Signal
- (2) Return

- C.** Perform a 45 N (10 lb) pull test on each of the wires that are associated with the marine transmission oil temperature sensor.
- D.** Check the allen head screw on each ECM connector for the proper torque. Refer to the diagnostic functional test Troubleshooting, "Electrical Connectors - Inspect".
- E.** Check the harness and wiring for abrasions and for pinch points from the marine transmission oil temperature sensor to the ECM.

Expected Result:

All connectors, pins, and sockets are completely coupled and/or inserted. The harness and wiring are free of corrosion, of abrasion, and of pinch points.

Results:

- OK – The connectors and wiring are OK. Proceed to Test Step 2.
- Not OK – There is a problem in the connectors and/or wiring.

Repair: Repair the wiring and/or the connectors. Replace parts, if necessary. Ensure that all of the seals are properly in place and ensure that the connectors are completely coupled.

Verify that the repair eliminates the problem.

STOP.

Test Step 2. Check for Active Diagnostic Codes

- A.** Connect the electronic service tool to the service tool connector.
- B.** Restore the electrical power to the ECM.
- C.** Monitor the active diagnostic code screen on electronic service tool. Check and record any active diagnostic codes.

Note: Wait at least 30 seconds in order for the diagnostic codes to become active.

- D.** Look for an 03 diagnostic code or an 04 diagnostic code for the marine transmission oil temperature sensor.

Expected Result:

No diagnostic codes are active.

Results:

- OK – No diagnostic codes are active.

Repair: The problem may have been related to a faulty connection in the harness. Carefully reinspect the connectors and wiring. Refer to the diagnostic functional test Troubleshooting, “Electrical Connectors - Inspect”.

STOP.

- Not OK – An 04 diagnostic code is active. Proceed to Test Step 3.
- Not OK – An 03 diagnostic code is active. Proceed to Test Step 5.

Test Step 3. Check the Supply Voltage at the Harness Connector for the Sensor

- Remove the electrical power from the ECM.
- Disconnect the harness connector for the sensor.
- Restore the electrical power to the ECM.
- Measure the voltage between terminals 1 (Signal) and 2 (sensor return) at the harness connector for the sensor.
- Remove the electrical power from the ECM.
- Connect the sensor's harness connectors.

Expected Result:

The voltage is 5.0 ± 0.2 VDC.

Results:

- OK – The voltage is 5.0 ± 0.2 VDC. The voltage is correct. Proceed to Test Step 4.
- Not OK – The voltage is not 5.0 ± 0.2 VDC. The voltage is incorrect.

Repair: Perform the diagnostic functional test Troubleshooting, “Analog Sensor Supply Circuit - Test”.

STOP.

Test Step 4. Disconnect the Sensor in Order to Create an Open Circuit

- Remove the electrical power from the ECM.
- Disconnect the harness connector for the sensor.

- Restore the electrical power to the ECM. Wait at least 30 seconds for activation of the diagnostic codes.

- Access the “Active Diagnostic Codes” screen on the electronic service tool and check for an active 03 diagnostic code for the sensor.

- Remove the electrical power from the ECM.

Expected Result:

An 03 diagnostic code is now active for the sensor.

Results:

- OK – An 04 diagnostic code was active before disconnecting the sensor. An 03 diagnostic code became active after the sensor was disconnected.

Repair: Temporarily connect a new sensor to the harness, but do not install the new sensor in the transmission. Verify that there are no active diagnostic codes for the sensor. If there are no active diagnostic codes for the sensor, permanently install the new sensor. Clear any logged diagnostic codes.

Verify that the repair eliminates the problem.

STOP.

- Not OK – The 04 diagnostic code is still present. Leave the sensor disconnected. Proceed to Test Step 6.

Test Step 5. Create a Short at the Harness Connector

- Remove the electrical power from the ECM.
- Install a jumper wire between terminals 1 and 2 on the harness connector for the sensor.
- Restore the electrical power to the ECM.
- Wait at least 30 seconds for activation of the 04 diagnostic code.

Note: Monitor the “Active Diagnostic Codes” screen on the electronic service tool before installing the jumper wire and after installing the jumper wire.

- Remove the jumper wire. Check for an 04 diagnostic code again.

- Remove the electrical power from the ECM.

Expected Result:

An 04 diagnostic code is active when the jumper wire is installed. An 03 diagnostic code is active when the jumper wire is removed.

Results:

- OK – The engine harness and the ECM are OK.

Repair: Temporarily connect a new sensor to the harness, but do not install the new sensor in the transmission. Verify that there are no active diagnostic codes for the sensor. If there are no active diagnostic codes for the sensor, permanently install the new sensor. Clear any logged diagnostic codes.

STOP.

- Not OK – The 03 diagnostic code remains active with the jumper in place. Proceed to Test Step 6.

Test Step 6. Check the Operation of the ECM

A. Remove the electrical power from the ECM.

B. Check the operation of the ECM by creating an open circuit at the ECM:

- a. Remove terminal P2-49 (signal).
- b. Remove terminal P2-44 (return).
- c. Restore the electrical power to the ECM. Monitor the “Active Diagnostic Code” screen on the electronic service tool. Wait at least 30 seconds for activation of the code.

An 03 diagnostic code should be active for the sensor.

C. Check the operation of the ECM by creating a short at the ECM:

- a. Install a wire jumper between terminals P2-49 (signal) and P2-44 (return).
- b. Monitor the “Active Diagnostic Code” screen on electronic service tool. Wait at least 30 seconds for activation of the code.

An 04 diagnostic code should be active when the wire jumper is installed.

- c. Remove the wire jumper. Return all wiring to the original configuration.

Expected Result:

An 03 diagnostic code is active when the signal wire is removed from the ECM connector. An 04 diagnostic code is active when the signal wire is connected to the return wire.

Results:

- OK – The ECM is working properly. The problem is in the wiring between the ECM and the harness connector. There may be a problem in a connector.

Repair: Repair the wire and/or the connector. Replace parts, if necessary.

Verify that the problem is resolved.

STOP.

- Not OK – One of the following conditions exists: The 03 diagnostic code is not active when the sensor signal wire is disconnected. The 04 diagnostic code is not active when the wire jumper is installed.

Repair: Replace the ECM. Refer to electronic troubleshooting Troubleshooting, “Replacing the ECM”. Verify that the original problem is resolved.

STOP.

i04012416

Wastegate Solenoid - Test

System Operation Description:

This procedure is only applicable to engines that have a wastegate regulator.

Use this procedure under the following conditions:

Use this procedure if another procedure has directed you here. Use this procedure if any of the following diagnostic codes are active:

- 0526-05 Turbo Wastegate Drive current below normal
- 0526-06 Turbo Wastegate Drive current above normal
- 0526-07 Turbo Wastegate Drive not responding properly

Some engine models will have a turbocharger with an electronically controlled wastegate. Typically, the wastegate is a mechanical valve that is used in the turbocharger in order to regulate the intake manifold pressure to a set value.

The control system for the electronically controlled wastegate precisely regulates the intake manifold pressure by using a wastegate regulator to control the wastegate.

The required intake manifold pressure is calculated by the software that is contained in the Electronic Control Module (ECM). The ECM uses the wastegate regulator to control the wastegate in order to provide the precise value of intake manifold pressure. The wastegate regulator is controlled by a PWM signal from the ECM.

Table 35

Pin Connections		
Sensor Pin	Function	P2 Pin Connection
1	Ground	19
2	Signal	17

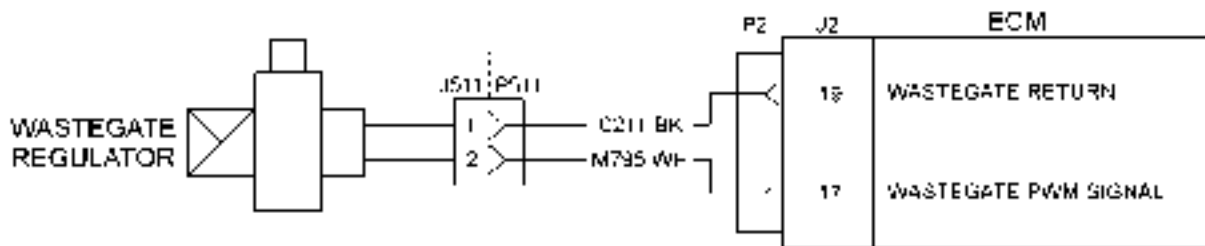

Illustration 93

Schematic for the wastegate regulator

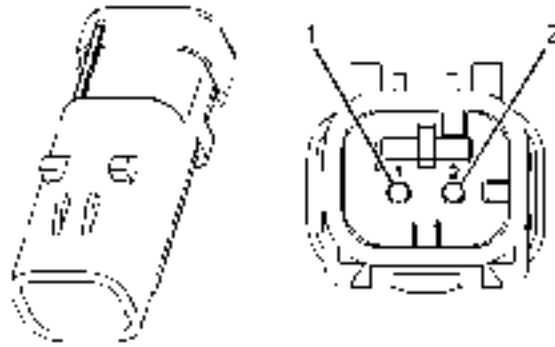

Illustration 94
Wastegate regulator connector
(1) Ground (GND)

g01806858

(2) Signal (SIG)

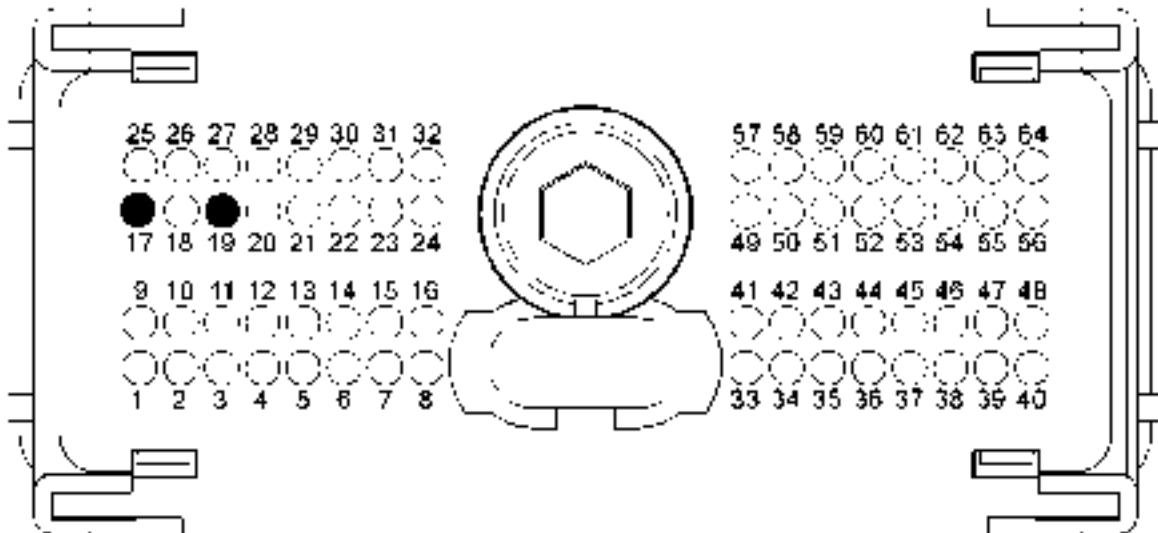

Illustration 95
Typical view of the pin locations on the P1 connector
(17) Wastegate pulse width modulation (PWM) signal
(19) Wastegate return

g02184796

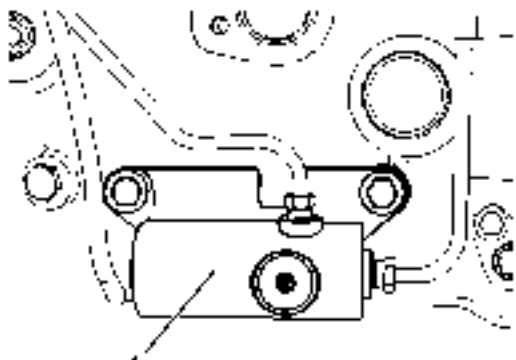

Illustration 96
Typical example
(1) Wastegate regulator

g01806873

Test Step 1. Check for Diagnostic Codes

- A. Turn the keyswitch to the OFF position.
- B. Connect the electronic service tool to the diagnostic connector.
- C. Turn the keyswitch to the ON position. Start the Perkins EST.
- D. Monitor the electronic service tool for active diagnostic codes and/or logged diagnostic codes.

Expected Result:

One or more diagnostic codes are active or logged.

Results:

- Diagnostic codes 526-5 and/or 526-6 are active and/or logged – Proceed to Test Step 2.
- No Codes – The fault seems to be resolved.

Repair: For intermittent faults, refer to Troubleshooting, “Electrical Connectors - Inspect”.

STOP.

Test Step 2. Inspect Electrical Connectors and Wiring

- Thoroughly inspect the P2/J2 ECM connector and the P511 connector for the wastegate regulator. Refer to Troubleshooting, “Electrical Connectors - Inspect” for details.
- Perform a 45 N (10 lb) pull test on each of the wires that are associated with the wastegate solenoid.
- Check the screw for the ECM connector for the correct torque of 5.0 N·m (44 lb in).

Expected Result:

All connectors, pins, and sockets are completely coupled and/or inserted and the harness is free of corrosion, abrasion, and pinch points.

Results:

- OK – The harness is OK. Proceed to Test Step 3.
- Not OK – There is a fault in the connectors and/or the harness.

Repair: Repair the connectors or the harness or replace the connectors or the harness. Ensure that all of the seals are correctly installed and ensure that the connectors are completely coupled.

Use the electronic service tool in order to clear all logged diagnostic codes and then verify that the repair eliminates the fault.

STOP.

Test Step 3. Determine the Diagnostic Code that is Active

- Turn the keyswitch to the ON position. Access the “Diagnostics Tests” on the electronic service tool. Activate the “Turbo Wastegate Solenoid Test”. Wait at least 30 seconds in order for the result to be displayed.
- Determine if the fault is related to either of the following:

- “Low current” (open circuit)
- “High current” (short circuit)

Expected Result:

The electronic service tool displays no diagnostic codes.

Results:

- OK – There are no active codes.

Repair: The original codes may have been caused by a loose connector. If this is an intermittent fault, refer to Troubleshooting, “Electrical Connectors - Inspect”.

STOP.

- Not OK – Diagnostic code 526-5 is active at this time. Proceed to Test Step 4.
- Not OK – Diagnostic code 526-6 is active at this time. Proceed to Test Step 6.
- Not OK – Diagnostic code 526-7 is active at this time. Proceed to Test Step 4.

Test Step 4. Create a Short Circuit in the Harness at the Solenoid

- Turn the keyswitch to the OFF position.
- Disconnect the P511 connector for the wastegate regulator.
- Fabricate a jumper wire between P511:1 and P511:2 in order to create a short circuit.
- Turn the keyswitch to the ON position. Access the “Diagnostics Tests” on the electronic service tool. Activate the “Turbo Wastegate Solenoid Test”. Wait at least 30 seconds in order for the result to be displayed.
- Check for active diagnostic codes on the electronic service tool.

Expected Result:

Diagnostic code 526-6 is now active.

Results:

- OK – Diagnostic code 526-6 is now active. There is a fault in the wastegate regulator.

Repair: Perform the following procedure:

- Temporarily connect a replacement wastegate regulator.

2. Turn the keyswitch to the ON position. Access the “Diagnostics Tests” on the electronic service tool. Activate the “Turbo Wastegate Solenoid Test”. Wait at least 30 seconds in order for the result to be displayed.
3. Diagnostic code 526-6 is no longer active.
4. If the fault is eliminated, reconnect the suspect wastegate regulator. If the fault returns, permanently install the replacement wastegate regulator.

STOP.

- Not OK – The low current diagnostic code (open circuit) is still active. Proceed to Test Step 5.

Test Step 5. Create a Short Circuit at the ECM

- A. Turn the keyswitch to the OFF position.
- B. Temporarily remove the wires from P2:17 and P2:19.
- C. Fabricate a jumper wire between P2:17 and P2:19 in order to create a short circuit.

Note: The P2/J2 connector must be connected during the next step.

- D. Turn the keyswitch to the ON position. Access the “Special Tests” under the “Diagnostics” menu on the electronic service tool. Activate the “Turbo Wastegate Solenoid Output” on the electronic service tool. Wait at least 30 seconds for activation of the diagnostic codes.
- E. Check for active diagnostic codes on the electronic service tool.

Expected Result:

Diagnostic code 526-6 is now active.

Results:

- OK – Diagnostic code 526-6 is now active. There is a fault in the harness between the ECM and the wastegate regulator.

Repair: Repair the harness or replace the harness.

Use the electronic service tool in order to clear all logged diagnostic codes and then verify that the repair eliminated the fault.

STOP.

- Not OK – There is still an open circuit diagnostic code.

Repair: Perform the following procedure:

1. Make sure that the latest flash file for the application is installed in the ECM. Refer to Troubleshooting, “Flash Programming”.
2. Contact the Global Technical Support Center.

Note: This consultation can greatly reduce the repair time.

3. If the Global Technical Support Center recommends the use of a test ECM, install a test ECM. Refer to Troubleshooting, “Replacing the ECM”.
4. Use the electronic service tool to recheck the system for active diagnostic codes.
5. If the fault is resolved with the test ECM, reconnect the suspect ECM.
6. If the fault returns with the suspect ECM, replace the ECM.
7. Use the electronic service tool in order to clear all logged diagnostic codes and then verify that the repair eliminates the fault.

STOP.

Test Step 6. Disconnect the Wastegate Regulator in order to Create an Open Circuit

- A. Turn the keyswitch to the OFF position.
- B. Disconnect the P511 connector for the wastegate regulator in order to create an open circuit.
- C. Turn the keyswitch to the ON position. Access the “Diagnostics Tests” on the electronic service tool. Activate the “Turbo Wastegate Solenoid Test”. Wait at least 30 seconds in order for the result to be displayed.
- D. Check for active diagnostic codes on the electronic service tool.

Expected Result:

Diagnostic code 526-5 is now active.

Results:

- OK – Diagnostic code 526-5 is now active.

Repair: There is a short in the solenoid of the wastegate regulator.

1. Temporarily connect a replacement wastegate regulator.

2. If the fault is eliminated, reconnect the suspect wastegate regulator. If the fault returns, permanently install the replacement wastegate regulator.

STOP.

- Not OK – Diagnostic code 526-6 is still active. Proceed to Test Step 7.

Test Step 7. Create an Open Circuit at the ECM

- A. Turn the keyswitch to the OFF position.
- B. Remove the wires from P2:17 and P2:19 in order to create an open circuit at the ECM.
- C. Turn the keyswitch to the ON position. Access the “Diagnostics Tests” on the electronic service tool. Activate the “Turbo Wastegate Solenoid Test”. Wait at least 30 seconds in order for the result to be displayed.
- D. Check for active diagnostic codes on the electronic service tool.

Expected Result:

Diagnostic code 526-5 is now active.

Results:

- OK – Diagnostic code 526-5 is now active. There is a short circuit in the harness between the ECM and the wastegate regulator.

Repair: Repair the harness or replace the harness.

Use the electronic service tool in order to clear all logged diagnostic codes and then verify that the repair eliminated the fault.

STOP.

- Not OK – Diagnostic code 526-6 is still present.

Repair: Perform the following procedure:

1. Make sure that the latest flash file for the application is installed in the ECM. Refer to Troubleshooting, “Flash Programming”.
2. Contact the Global Technical Support Center.

Note: This consultation can greatly reduce the repair time.

3. If the Global Technical Support Center recommends the use of a test ECM, install a test ECM. Refer to Troubleshooting, “Replacing the ECM”.

4. Use the electronic service tool to recheck the system for active diagnostic codes.

5. If the fault is resolved with the test ECM, reconnect the suspect ECM.

6. If the fault returns with the suspect ECM, replace the ECM.

7. Use the electronic service tool in order to clear all logged diagnostic codes and then verify that the repair eliminates the fault.

STOP.

Index

Numerics

5 Volt Sensor Supply Circuit - Test 115

A

Alternator Noise 38
 Probable Causes 38
 Recommended Actions 38
Alternator Will Not Charge 38
 Probable Causes 38
 Recommended Actions 38

B

Battery 39
 Probable Causes 39
 Recommended Actions 39

C

CAN Data Link Circuit - Test 122
Can Not Reach Top Engine RPM 39
 Probable Causes 39
 Recommended Actions 39
CID 0001 FMI 02 74
CID 0001 FMI 05 74
CID 0001 FMI 06 75
CID 0001 FMI 07 75
CID 0002 FMI 02 75
CID 0002 FMI 05 76
CID 0002 FMI 06 76
CID 0002 FMI 07 77
CID 0003 FMI 02 77
CID 0003 FMI 05 77
CID 0003 FMI 06 78
CID 0003 FMI 07 78
CID 0004 FMI 02 79
CID 0004 FMI 05 79
CID 0004 FMI 06 80
CID 0004 FMI 07 80
CID 0005 FMI 02 80
CID 0005 FMI 05 81
CID 0005 FMI 06 81
CID 0005 FMI 07 82
CID 0006 FMI 02 82
CID 0006 FMI 05 83
CID 0006 FMI 06 83
CID 0006 FMI 07 84
CID 0041 FMI 03 84
CID 0041 FMI 04 84
CID 0091 FMI 08 85
CID 0091 FMI 13 85
CID 0094 FMI 03 85
CID 0094 FMI 04 85
CID 0096 FMI 03 86
CID 0096 FMI 04 86

CID 0100 FMI 03 86
CID 0100 FMI 04 87
CID 0100 FMI 10 87
CID 0110 FMI 03 87
CID 0110 FMI 04 88
CID 0127 FMI 03 88
CID 0127 FMI 04 88
CID 0168 FMI 00 89
CID 0168 FMI 01 89
CID 0168 FMI 02 89
CID 0172 FMI 03 90
CID 0172 FMI 04 90
CID 0174 FMI 03 91
CID 0174 FMI 04 91
CID 0177 FMI 03 91
CID 0177 FMI 04 91
CID 0190 FMI 08 92
CID 0253 FMI 02 92
CID 0261 FMI 11 92
CID 0262 FMI 03 93
CID 0262 FMI 04 93
CID 0268 FMI 02 93
CID 0342 FMI 08 94
CID 0342 FMI 11 94
CID 0526 FMI 05 94
CID 0526 FMI 06 95
CID 0526 FMI 07 95
CID 0535 FMI 03 96
CID 0535 FMI 04 96
CID 0774 FMI 08 96
CID 0774 FMI 13 97
CID 1779 FMI 05 97
CID 1779 FMI 06 97
CID 1785 FMI 03 98
CID 1785 FMI 04 98
CID 1785 FMI 10 98
CID 1797 FMI 03 99
CID 1797 FMI 04 99
CID 1834 FMI 02 100
CID 2246 FMI 05 100
CID 2246 FMI 06 100
Coolant in Engine Oil 40
 Probable Causes 40
 Recommended Actions 41
Coolant Level Sensor Circuit - Test 126
Coolant Temperature Is Too High 41
 Probable Causes 41
 Recommended Actions 41
Customer Specified Parameters 33
 Configurable Inputs 33
 ECM Identification Parameter 33
 Engine Rating Parameter 33
 Low Idle Parameters 33
Customer Specified Parameters Table 35
Customer Specified Parameters Worksheet 36

D

Data Link Circuit - Test 131

Diagnostic Code Cross Reference	71	Engine Pressure Sensor Open or Short Circuit - Test	146
Diagnostic Codes	69	Engine Speed Does Not Change	50
Active Diagnostic Codes	70	Probable Causes	50
Diagnostic Codes	69	Recommended Repairs	50
Logged Diagnostic Codes	70	Engine Speed/Timing Sensor Circuit - Test	154
Diagnostic Functional Tests	115	Engine Stalls at Low RPM	50
		Probable Causes	50
E		Recommended Actions	50
E096 High Fuel Pressure	104	Engine Temperature Sensor Open or Short Circuit - Test	159, 165
E1044 High Intake Manifold Pressure	112	Engine Vibration	51
E1045 Low Intake Manifold Pressure	112	Probable Causes	51
E113 High Transmission Oil Pressure	104	Recommended Actions	51
E119 Low Fuel Level	105	Engine Will Not Crank	52
E179 Alternator Not Charging	105	Probable Causes	52
E194 High Exhaust Temperature	105	Recommended Repairs	52
E198 Low Fuel Pressure	106	Engine Wiring Information	23
E2143 Low Engine Coolant Level	113	Harness Wire Identification	23
E232 High Fuel/Water Separator Water Level	106	Schematic Diagrams	24
E268 Unexpected Engine Shutdown	107	Event Codes	102
E360 Low Engine Oil Pressure	107	Excessive Black Smoke	53
E361 High Engine Coolant Temperature	108	Probable Causes	53
E362 Engine Overspeed	109	Recommended Actions	53
E363 High Fuel Supply Temperature	109	Excessive Engine Oil Consumption	54
E396 High Fuel Rail Pressure	110	Probable Causes	54
E398 Low Fuel Rail Pressure	110	Recommended Actions	54
E539 High Intake Manifold Air Temperature	111	Excessive Fuel Consumption	55
E877 High Transmission Oil Temperature	112	Probable Causes	55
ECM Harness Connector Terminals	28	Recommended Actions	56
Removal and Installation of the Harness Connector Terminals	28	Excessive Valve Lash	57
ECM Memory - Test	137	Probable Causes	57
ECM Will Not Accept Factory Passwords	42	Recommended Actions	57
Probable Causes	42	Excessive White Smoke	58
Recommended Actions	42	Probable Causes	58
ECM Will Not Communicate with Other Systems or Display Modules	42	Recommended Actions	58
Probable Causes	42	Exhaust Temperature Is High	59
Recommended Actions	42	Probable Causes	59
Electrical Connectors - Inspect	138	Recommended Actions	59
Electrical Power Supply Circuit - Test	142		
Electronic Service Tool Will Not Communicate with ECM	43	F	
Probable Causes	43	Factory Passwords	30
Recommended Actions	43	Flash Codes	69
Electronic Service Tools	12	Flash Programming	31
Optional Service Tools	12	Flash Programming a Flash File	31
Perkins Electronic Service Tool	13	Fuel Dilution of Engine Oil	59
Required Service Tools	12	Probable Causes	59
Electronic Troubleshooting	5	Recommended Actions	59
Engine Cranks but Will Not Start	44	Fuel Level - Test	170
Probable Causes	44	Fuel Rail Pump Solenoid - Test	173
Recommended Actions	44		
Engine Has Early Wear	47	G	
Probable Causes	47	Glossary	8
Recommended Actions	47		
Engine Misfires, Runs Rough or Is Unstable	48		
Probable Causes	48	I	
Recommended Actions	48	Ignition Keyswitch Circuit and Battery Supply Circuit - Test	177
Engine Oil in Cooling System	49		
Probable Causes	49		
Recommended Actions	49		

Important Safety Information	2
Indicator Lamp Circuit - Test.....	183
Indicator Lamps.....	14
Color of Lamps.....	15
Flash Codes.....	16
Functions of the Lamps.....	14
Indicator Lamps	14
Operation of the Indicator Lamps.....	16
Injector Data Incorrect - Test	186
Injector Solenoid Circuit - Test.....	188
Injector Trim File.....	31
Intermittent Engine Shutdown	59
Probable Causes	59
Recommended Actions.....	60
Intermittent Low Power or Power Cutout.....	60
Probable Causes	60
Recommended Actions.....	61

L

Low Engine Oil Pressure	62
Probable Causes	62
Recommended Actions.....	62
Low Power/Poor or No Response to Throttle	63
Probable Causes	63
Recommended Actions.....	63

M

Mechanical Noise (Knock) in Engine.....	65
Probable Causes	65
Recommended Actions.....	65

N

No Diagnostic Codes Detected	73
Noise Coming from Cylinder.....	65
Probable Causes	65
Recommended Actions.....	66

P

Poor Acceleration or Response.....	66
Probable Causes	66
Recommended Actions.....	66
Programming Parameters	30

R

Replacing the ECM.....	17
------------------------	----

S

Self-Diagnostics.....	18
Sensors and Electrical Connectors	19
Speed Control (PWM) - Test.....	196
Starting Aid (Glow Plug) Relay Circuit - Test.....	201
Switch Circuits - Test	205
System Configuration Parameters.....	37
ECM Software Release Date	37
Engine Serial Number.....	37
Full Load Setting.....	37
Full Torque Setting.....	37
Rating Interlock.....	37
System Overview.....	6
Diagnostic Codes.....	8
Passwords	8
Programmable Parameters.....	8
System Operation	6

T

Table of Contents.....	3
Test ECM Mode.....	30
Throttle Position Sensor - Test	207
Transmission Oil Pressure Is High	67
Probable Causes	67
Recommended Actions.....	67
Transmission Oil Temperature - Test.....	209
Transmission Oil Temperature Is High	68
Probable Causes	68
Recommended Actions.....	68
Troubleshooting Section.....	5
Troubleshooting with a Diagnostic Code	69
Troubleshooting with an Event Code.....	102
Troubleshooting without a Diagnostic Code	38

W

Wastegate Solenoid - Test.....	212
--------------------------------	-----